







2- CONNECTORS

	CLOSED END CONNECTORS	40
	SPEED-EASE CONNECTORS	
	Standard Type	41
	Winged Type	41
	High Temperature	42
	SPEED-E CONNECTORS	42
	BUTT CONNECTORS	
	Non-insulated	43
	Vinyl Insulated	44
	Nylon Insulated	44
	Nylon Insulated Window w/ Sleeve	45
	Step Down, Vinyl Insulated	46
	PARALLEL CONNECTORS	
	Non-insulated	46
	Vinyl Insulated	47
	Nylon Insulated	47
	WIRE PINS	
	Non-insulated	48
	Vinyl Insulated	48
	Nylon Insulated	49



Connectors

Closed End Connectors

Material: 6/6 Nylon UL94V2

Insert: Tin Plated Copper

Temperature: 105°C, HR Style 150C

Maximum Electrical Rating: 22-16: 10 Amps

16-14: 15 Amps

12-10: 24 Amps

T= Material Thickness

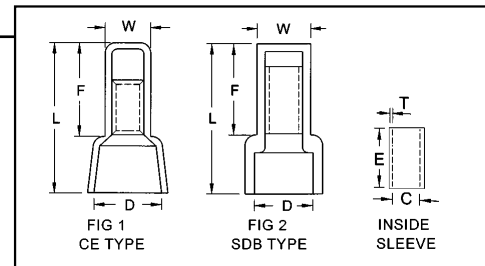

HOFFMAN PART NO.	WIRE SIZE	WIRE COMBINATION MIN / MAX	VOLTAGE UL/CSA	DIMENSIONS (INCHES)							MOUNTED	UL	TAPE REEL QTY	DIE FOR HAND TOOL MOUNTED	
				L	W	F	D	E	T	C					
2218SDB	22-18	2#20 +2 #22 2 #18	300/300	0.598	0.197	0.346	0.236	0.276	0.020	0.091	Y		500	3S2218A	YS2210 or YS7
2218SDB/J	22-18	2#22 + 1 #20 2#18	600/300	0.598	0.197	0.366	0.244	0.315	0.0197	0.087	Y		500	3S2218A	YS7
1614SDB	16-14	4 to 5 #22 1 #18 + 1 #16	300/300	0.598	0.228	0.346	0.248	0.276	0.018	0.122	Y		500	3SB1614A	YS2210 or YS7
1614SDB/J	16-14	2#22 + 1 #20 2#16	600/300	0.598	0.230	0.366	0.256	0.315	0.0197	0.098	Y		500	3SB1614A	YS7
1210SDB	12-10	1 #22 + 3 #20 + 1 #18 or 16 or 2 #18 +1 #16 or #14 or #12	300/300	0.701	0.287	0.346	0.362	0.295	0.0280	0.157	Y		400	3S1210A	YS2210 or YS7
1210SDB/J	12-10	1 #22 + 4 #20 2 #14	600/300	0.701	0.289	0.386	0.370	0.335	0.0315	0.138	Y		400	3S1210A	YS7
8SDB	8	2 #20 + 1 #14 or 1 #16 1 #12 + 1 #12 or 1 #10	300/300	0.866	0.370	0.465	0.465	0.315	0.0490	0.197	Y		NA	NA	YS8S
8SDB/J	8	3 #20 + 1 #12 1 #12 + 1 #10	600/300	0.874	0.366	0.472	0.472	0.374	0.0490	0.181	Y		NA	NA	YS8S
CE100	22-18	2#22 2 #20 + 1 #18	300/300	0.709	0.191	0.465	0.244	0.265	0.016	0.102	Y		NA	NA	YS7
CE233	16-14	2 #22 1 #18 + 1 #14	300/300	0.776	0.211	0.493	0.311	0.271	0.076	0.121	Y		NA	NA	YS7
CE551	12-10	2 #22 + 2 #18 3 #18 + 1 #12	300/300	1.004	0.283	0.626	0.413	0.271	0.023	0.172	Y		NA	NA	YS7
CE550/J	12-10	1 #22 + 2 # 20 + 1 #12 8 #22	600/300	1.063	0.366	0.591	0.374	0.335	0.032	0.15	Y		NA	NA	YS7
CE800	8	2 #16 + 1 #10 2 #16 + 1 #12	300/600	1.091	0.359	0.619	0.488	0.332	0.037	0.209	Y		NA	NA	YS8S
CE100R	22-18	2#20 2#20 + 1 #18	300	0.709	0.191	0.465	0.244	0.265	0.016	0.102	Y		NA	NA	YS7
CE233R	16-14	2#22 4#18	300	0.7874	0.211	0.493	0.283	0.271	0.076	0.121	Y		NA	NA	YS7
CE551R	12-10	3#18 3#14	300	1.0039	0.283	0.626	0.378	0.271	0.023	.0172	Y		NA	NA	YS7
CE233HR	16-14	2#22 4#18	300	0.7874	0.211	0.493	0.283	0.271	0.076	.0121	Y		NA	NA	YS7
CE551HR	12-10	3#18 3#14	300	1.0039	0.283	0.262	0.378	0.271	0.023	.0172	Y		NA	NA	YS7



Speed-Ease Connectors

SPEED-Ease Standard Connectors

Cap Material: UL 94V2 Thermoplastic
 Inner Spring: Zinc Plated Steel
 Temperature: 105°C

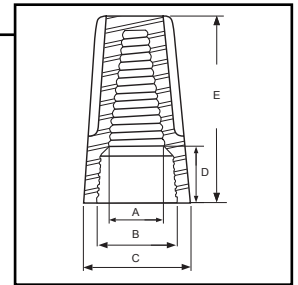

HOFFMAN PART NO.	WIRE RANGE	COLOR	WIRE COMBINATION		VOLTAGE	DIMENSIONS (INCHES)					UL
			MIN	MAX		A	B	C	D	E	
HE1	22-14	Grey	2 #22	1 #14 + 1 #20	300	0.150	0.264	0.339	0.228	0.598	Y
HE2	22-14	Blue	2 #22	3 #16	300	0.161	0.276	0.386	0.232	0.693	Y
HE3/600V	22-14	Orange	1 #18 + 1 #20	4 #16 + 1 #16	600*	0.197	0.390	0.480	0.307	0.866	Y
SEHE3/600V	22-14	Orange	1 #18 + 1 #20	4 #16 + 1 #20	600*	0.197	0.390	0.480	0.307	0.862	Y
HE4/600V	22-10	Yellow	3 #20	1 #10 + 2 #14 + 1 #16	600*	0.236	0.441	0.551	0.311	0.945	Y
SEHE4/600V	22-10	Yellow	3 #20	1 #10 + 2 #14 + 1 #16	600*	0.236	0.441	0.551	0.311	0.937	Y
HE5	22-8	Red	3 #18	3 #10	600*	0.295	0.511	0.645	0.360	1.042	Y
SEHE5	22-8	Red	3 #18	3 #10	600*	0.276	0.504	0.630	0.350	1.047	Y

* 1000 Volt in fixtures and signs

SPEED-Ease Winged Type Connectors

Cap Material: UL 94V2 Thermoplastic
 Inner Spring: Zinc Plated Steel
 Temperature: 105°C

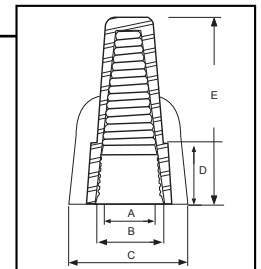

HOFFMAN PART NO.	WIRE RANGE	COLOR	WIRE COMBINATION		*VOLTAGE UL/CSA	DIMENSIONS (INCHES)					UL
			MIN	MAX		A	B	C	D	E	
HE3YW	18-10	Yellow	2 #18	3 #12	600/300	0.252	0.386	0.717	0.354	1.016	Y
HE4TW	22-8	Tan	3 #22	3 #10	600/300	0.283	0.457	0.720	0.362	1.142	Y
HE5RW	18-8	Red	3 #16	5 #12	600	0.354	0.531	0.906	0.378	1.252	Y
HE6GW	18-8	Grey	3 #14 + 1 #18	3 #10	600	0.394	0.587	1.000	0.394	1.311	Y
HE7BW	14-6	Blue	2 #10 + 1 #12	1 #8 + 3 #10	600	0.472	0.740	1.260	0.516	1.575	Y
HE9GD	14-10	Green Grounding	2 #14	3 #12 + 1 #14	600	0.327	0.476	0.795	0.370	1.134	Y

* 1000 Volt in fixtures and signs



SPEED-Ease High Temperature Connectors

Cap Material: UL 94V2 Thermoplastic
Inner Spring: Zinc Plated Steel (applicable to non-ceramic only)
Temperature: 150°C, 600V (Black Thermoplastic)
 Over 150°C (Ceramic, no inner spring)

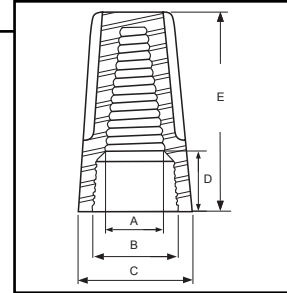

HOFFMAN PART NO.	WIRE RANGE	TYPE	WIRE COMBINATION		VOLTAGE	DIMENSIONS (INCHES)					UL
			MIN	MAX		A	B	C	D	E	
HE1H	22-14	Black Thermoplastic	3 #22	2 #16	300	0.150	0.264	0.339	0.228	0.582	Y
HE3H	22-14	Black Thermoplastic	3 #20	2 #14 + 1 #16	600	0.197	0.390	0.480	0.307	0.866	Y
HE2HC	18-14	Ceramic	2#16	1 #14 + 1 #16	300	0.187	0.250	0.406	NA	0.687	Y
HE3HC	18-14	Ceramic	2 Or 3 #16	2#16 + 1 or 2 #18	300	0.203	0.312	0.484	NA	0.750	Y
HE4HC	18-14	Ceramic	2 #14	3 #16 + 1 #18	300	0.218	0.406	0.531	NA	0.843	Y
HE5HC	14-12	Ceramic	2 or 3 #14	2 #12	300	0.437	0.468	0.703	NA	1.000	Y

Speed-E Connectors

Housing Material: UL 94V2 Thermoplastic
Inner Sleeve Material: Stainless Steel with Brass Contact Strip
Voltage: 600V
Temperature: 110°C

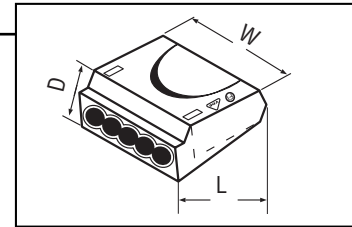

HOFFMAN PART NO.	WIRE RANGE	COLOR	DIMENSIONS (INCHES)			UL
			L	W	D	
SPEEDE2	12-22 solid only	Red	0.776	0.413	0.374	Y
SPEEDE3	12-22 solid only	Orange	0.776	0.531	0.374	Y
SPEEDE4	12-22 solid only	Yellow	0.776	0.677	0.374	Y
SPEEDE5	12-22 solid only	Gray	0.776	0.817	0.374	Y
SPEEDE8	12-22 solid only	Black	0.677	0.776	0.661	Y
SPEEDE2CL	12-22 solid only	Clear w/ Red	0.768	0.413	0.374	Y
SPEEDE3CL	12-22 solid only	Clear w/ Orange	0.776	0.531	0.374	Y
SPEEDE4CL	12-22 solid only	Clear w/ Yellow	0.776	0.677	0.374	Y
SPEEDE5CL	12-22 solid only	Clear w/ Gray	0.776	0.831	0.374	Y
SPEEDE8CL	12-22 solid only	Clear w/ Black	0.677	0.776	0.661	Y



Butt Connectors

Non-Insulated Butt Connectors

Material: Tin Plated Copper

Voltage: 176°C

Barrel Type: Tubular

T= Material Thickness

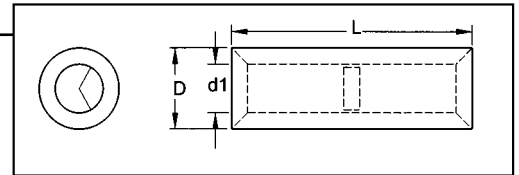

HOFFMAN PART NO.	WIRE SIZE	AMPS MAX	DIMENSIONS (INCHES)				UL	TAPE MOUNTED REEL QTY	DIE FOR TAPE MOUNTED	HAND TOOL
			L	D	d1	T				
C2622	26-22	9	.472	.083	.051	.016	Y	NA	NA	YHT2622
C2622/J	26-22	9	.472	.079	.047	.016	Y	NA	NA	YHT2622
C2216	22-16	18	.591	.130	.067	.031	Y	1000	3H2216	YHM228
C2216/J	22-16	18	.591	.130	.067	.031	Y	NA	NA	YHT2210
C1614	16-14	30	.591	.154	.091	.031	Y	1000	3H1614	YHM228
C1614/J	16-14	30	.591	.161	.091	.031	Y	NA	NA	YHT2210
C1210	12-10	50	.591	.213	.134	.039	Y	500	3H1210	YHM228
C1210/J	12-10	50	.591	.213	.134	.039	Y	NA	NA	YHT2210
C8R1	8	70	.827	.276	.181	.047	Y	NA	NA	YHM228
C6R1	6	95	1.024	.350	.232	.059	Y	NA	NA	
C4R1	4	125	1.142	.445	.307	.069	Y	NA	NA	AK60
C2R1	2	170	1.260	.520	.374	.073	Y	NA	NA	
C1/OR1	1/0	230	1.417	.602	.449	.077	Y	NA	NA	
C2/OR1	2/0	265	1.457	.689	.524	.083	Y	NA	NA	
C3/OR1	3/0	310	1.496	.768	.571	.098	Y	NA	NA	*Hydraulic
C4/OR1	4/0	360	1.496	.870	.646	.112	Y	NA	NA	Head
C150R1	300MCM	445	2.126	1.039	.768	.136	Y	NA	NA	603
C200R1	350MCM	505	2.244	1.122	.827	.148	Y	NA	NA	
C250R1	500MCM	620	2.480	1.276	.945	.165	Y	NA	NA	
C300R1	600MCM	690	2.835	1.457	1.102	.177	Y	NA	NA	

* Refer to Tool Selector Chart ([page 92-93](#)) for Tool Die Numbers.



Flared Vinyl Insulated Butt Connectors

Material: Tin Plated Copper
Maximum Electrical Rating: 75°C, 600V
Insulation Material: Vinyl

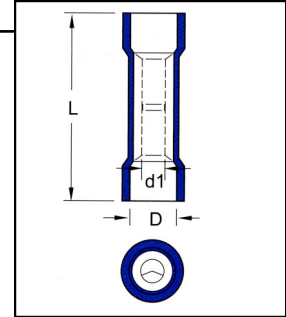

T = Material Thickness

HOFFMAN PART NO.	WIRE SIZE	BARREL TYPE	AMPS	DIMENSIONS (INCHES)					UL	TAPE MOUNTED REEL QTY	DIE FOR TAPE MOUNTED	HAND TOOL
				L	D	d1	T					
FVC2216WS	22-16	Butted Seam	9-18	.969	.157	.067	.031	Y	1000	3V2216		
BUTR	22-16	Butted Seam	9-18	.945	.110	.067	.029	N	NA	NA		
FVC2216	22-16	Tubular	9-18	.953	.157	.067	.031	Y	1000	3V2216		
FVC1614WS	16-14	Butted seam	18-30	.969	.177	.091	.031	Y	1000	3V1614	YNM2210	
BUTB	16-14	Butted Seam	18-30	.984	.145	.091	.029	N	NA	NA		
FVC1614	16-14	Tubular	18-30	.953	.177	.091	.031	Y	1000	3V1614		
FVC1210WS	12-10	Butted Seam	35-50	1.043	.248	.134	.039	Y	500	3V1210		
BUTY	12-10	Butted Seam	35-50	1.080	.205	.134	.029	N	NA	NA		
FVC1210	12-10	Tubular	35-50	1.024	.248	.134	.039	Y	500	3V1210		
FVC8R1	8	Butted Seam	70	1.398	.335	.177	.047	Y	NA	NA	YNM86	
FVC6R1	6	Tubular	95	1.772	.413	.232	.059	Y	NA	NA	YNM86	

Straight Nylon Insulated Butt Connector

Material: Tin Plated Copper
Maximum Electrical Rating: 105°C, 600V
Insulation Material: 6/6 Nylon

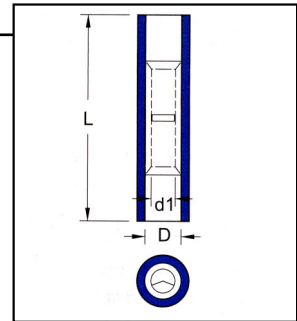

T = Material Thickness

HOFFMAN PART NO.	WIRE SIZE	BARREL TYPE	AMPS	DIMENSIONS (INCHES)					UL	TAPE MOUNTED REEL QTY	DIE FOR TAPE MOUNTED	HAND TOOL
				L	D	d1	T					
NC2622	26-22	Tubular	5.5 - 9	.787	.079	.051	.031	N	NA	NA	YNT2622	
NC2622/J	26-22	Tubular	5.5 - 9	.787	.079	.047	.031	Y	NA	NA	YNT2622	
NC2216	22-16	Tubular	9 - 18	1.075	.126	.067	.031	Y	1000	3V2216	YNM2210	
NCL2216	22-16	Brazed Seam	9 - 18	1.075	.126	.067	.031	Y	NA	NA	YNM2210	
NCL2216/J	22-16	Tubular	9 - 18	.894	.154	.067	.031	Y	NA	NA	YNT2216	
NC1614	16-14	Tubular	18 - 30	1.075	.150	.091	.031	Y	1000	3V1614	YNM2210	
NCL1614	16-14	Brazed Seam	18 - 30	1.075	.150	.091	.031	Y	NA	NA	YNM2210	
NC1210	12-10	Tubular	35 - 50	1.075	.209	.134	.031	Y	500	3V1210	YNM2210	
NCL1210	12-10	Brazed Seam	35 - 50	1.075	.209	.134	.031	Y	NA	NA	YNM2210	



Flared Nylon Insulated Butt Connector

Material: Tin Plated Copper
Maximum Electrical Rating: 105°C, 600V
Insulation Material: 6/6 Nylon

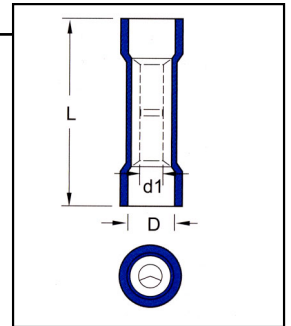

T= Material Thickness

HOFFMAN PART NO.	WIRE SIZE	BARREL TYPE	AMPS	DIMENSIONS (INCHES)					UL	TAPE MOUNTED REEL QTY	DIE FOR TAPE MOUNTED	HAND TOOL
				L	D	d1	T					
FNC2216	22-16	Tubular	9 - 18	0.992	0.157	0.067	0.031	Y	1000	3V2216	YNM2210	
FNC2216/J	22-16	Tubular	9 - 18	0.894	0.157	0.067	0.031	Y	1000	3V2216	YNT2216	
FNC2216WS	22-16	Butted Seam	9 - 18	0.992	0.157	0.067	0.031	Y	1000	3V2216	YNM2210	
FNC1614	16-14	Tubular	18 - 30	0.992	0.177	0.091	0.031	Y	1000	3V1614	YNM2210	
FNC1614/J	16-14	Tubular	18 - 30	0.894	0.177	0.091	0.031	Y	1000	3V1614	YNT1614	
FNC1614WS	16-14	Butted Seam	18 - 30	0.992	0.177	0.091	0.031	Y	1000	3V1614	YNM2210	
FNC1210	12-10	Tubular	35 - 50	1.110	0.248	0.134	0.039	Y	500	3V1210	YNM2210	
FNC1210/J	12-10	Tubular	35 - 50	1.051	0.268	0.134	0.039	Y	500	3V1210	YNT1210S	
FNC1210WS	12-10	Butted Seam	35 - 50	1.110	0.248	0.130	0.039	Y	500	3V1210	YNM2210	

Nylon Insulated Window with Sleeve

Material: Tin Plated Copper
Maximum Electrical Rating: 105°C, 600V
Insulation Material: 6/6 Nylon
Inside Sleeve Material: Tin Plated Copper

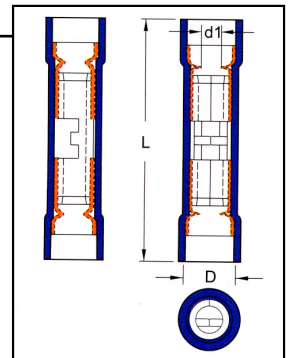

T= Material Thickness

HOFFMAN PART NO.	WIRE SIZE	BARREL TYPE	AMPS	DIMENSIONS (INCHES)					UL	TAPE MOUNTED REEL QTY	DIE FOR TAPE MOUNTED	HAND TOOL
				L	D	d1	T					
NDCW2216	22-16	Butted Seam	9 - 18	1.228	.169	.067	.031	Y	NA	NA		
NDCW1614	16-14	Butted Seam	18 - 30	1.228	.197	.091	.031	Y	NA	NA	YNM2210D	
NDCW1210	12-10	Butted Seam	35 - 50	1.575	.260	.134	.039	Y	NA	NA		



Vinyl Insulated Step Down Butt Connectors

Material: Tin Plated Copper
Maximum Electrical Rating: 75°C, 600V
Insulation Material: 6/6 Nylon
Inside Sleeve Material: Tin Plated Copper
Barrel: Tubular

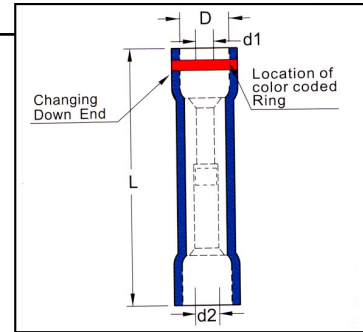

HOFFMAN PART NO.	WIRE SIZE	AMPS	DIMENSIONS (INCHES)				UL	TAPE MOUNTED REEL QTY	DIE FOR TAPE MOUNTED	HAND TOOL
			L	D	d1	d2				
FVC1614DW	16-14 to 22-16	9-18	.965	.177	.067	.091	Y	NA	NA	
FVC1210SDW	12-10 TO 22-16	9-50	1.220	.248	.067	.134	Y	NA	NA	YNM2210D
FVC1210DW	12-10-16-14	18-50	1.220	.248	.091	.134	Y	NA	NA	
FVC8SDW	8 to 16-14	18-70	1.406	.335	.091	.177	Y	NA	NA	
FVC8DW	8 to 12-10	35-70	1.406	.335	.134	.177	Y	NA	NA	YNM86
FVC6DW	4 to 8	70-125	1.172	.413	.177	.232	Y	NA	NA	

Parallel Connectors

Non-Insulated Parallel Connectors

Material: Tin Plated Copper
Maximum Electrical Rating: 176°C
Barrel Type: Tubular

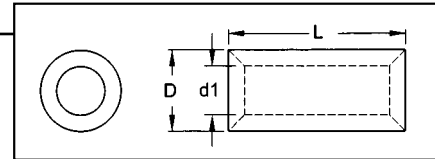

HOFFMAN PART NO.	WIRE SIZE	WIRE COMBINATION		AMPS	DIMENSIONS (INCHES)				UL	TAPE MOUNTED REEL QTY	DIE FOR TAPE MOUNTED	HAND TOOL
		MIN	MAX		L	D	d1	T				
P2216	22-16	2 #22	1 #18 + 1 #20	9 - 18	0.315	0.130	0.067	0.031	Y	NA	NA	
P2216/J	22-16	2 #22	2 #18	9 - 18	0.315	0.130	0.067	0.031	Y	NA	NA	YHM228
P1614	16-14	2 #16	1 #18 + 1 #20	18 - 30	0.315	0.154	0.091	0.031	Y	NA	NA	or
P1614/J	16-14	2 #22	1 #18 + 1 #16	18 - 30	0.315	0.161	0.091	0.031	Y	NA	NA	YHT2210
P1210	12-10	2 #18	2 #16	35 - 50	0.335	0.213	0.134	0.039	Y	NA	NA	
P1210/J	12-10	2 #18	2 #16	35 - 50	0.335	0.213	0.134	0.039	Y	NA	NA	
P8R1	8	1 #10 + 1 #16	2 #12	70	0.374	0.276	0.181	0.047	Y	NA	NA	YHM228
P8R1/J	8	2 #12	1 #12 + 1 #10	70	0.374	0.276	0.177	0.049	Y	NA	NA	YHT8S
P6R1	6	1 #8 + 1 #12	2 #10	95	0.433	0.350	0.232	0.059	Y	NA	NA	
P6R1/J	6	1 #12 + 1 #18	2 #10	95	0.433	0.350	0.228	0.061	Y	NA	NA	*604
P4R1	4	1 #8 + 1 #12	2 #8	125	0.531	0.445	0.307	0.069	Y	NA	NA	Hydraulic
P4R1/J	4	1 #8 + 1 #6	2 #8	125	0.531	0.445	0.303	0.071	Y	NA	NA	Head
P2R1	2	2 #6	4 #8	170	0.650	0.520	0.374	0.073	Y	NA	NA	
P1/OR1	1/0	2 #4	2 #6	230	0.748	0.602	0.449	0.077	Y	NA	NA	
P2/OR1	2/0	2 #2	1 #6 + 1 #1/0	265	0.748	0.689	0.524	0.083	Y	NA	NA	
P3/OR1	3/0	1 #4 + 1 #2/0	1 #4 + 1 #2/0	310	0.768	0.768	0.571	0.098	Y	NA	NA	
P4/OR1	4/0	2 #2/0	2 #2/0	360	0.787	0.870	0.646	0.112	Y	NA	NA	
P150R1	250-300MCM	2 #2/0	1 #10 + 1 #3/0	405-445	1.063	1.039	0.768	0.136	Y	NA	NA	*603
P250R1	350MCM	2 #3/0	1 #2/0 + 1 #4/0	505	1.122	1.122	0.827	0.148	Y	NA	NA	Hydraulic
P300R1	400-500 MCM	2 #4/0	1 #2/0 + 1 #250MCM	545-620	1.260	1.276	0.945	0.165	Y	NA	NA	Head

* Refer to Tool Selector Chart ([page 92-93](#)) for Tool Die Numbers.



Flared Vinyl Insulated Parallel Connectors

Material: Tin Plated Copper
Maximum Electrical Rating: 75°C, 600V
Barrel Type: Tubular
Insulation: Vinyl

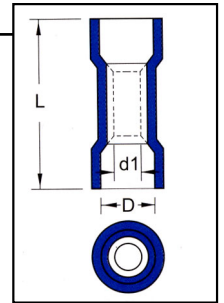

T= Material Thickness

HOFFMAN PART NO	WIRE SIZE	WIRE COMBINATION		AMPS	DIMENSIONS (INCHES)				UL	TAPE MOUNTED REEL QTY	DIE FOR TAPE MOUNTED	HAND TOOL
		MIN	MAX		L	D	d1	T				
FVP2216	22-16	2 #22	1 #18 + 1 #20	9 - 18	0.650	0.157	0.067	0.031	N	NA	NA	YNM2210
FVP2216/J	22-16	2 #22	2 #18	9 - 18	0.630	0.157	0.067	0.031	Y	NA	NA	or
FVP1614	16-14	2 #16	1 #18 + 1 #20	18 - 30	0.650	0.177	0.091	0.031	N	NA	NA	YNT2216
FVP1614/J	16-14	2 #22	1 #18 + 1 #16	18 - 30	0.630	0.177	0.091	0.031	Y	NA	NA	
FVP1210	12-10	2 #18	2 #16	35 - 50	0.795	0.248	0.134	0.039	N	NA	NA	YNM2210
FVP1210/J	12-10	2 #18	2 #16	35 - 50	0.807	0.268	0.134	0.039	Y	NA	NA	YNT1210S

Straight Nylon Insulated Parallel Connectors

Material: Tin Plated Copper
Maximum Electrical Rating: 105°C, 600V
Barrel Type: Tubular
Insulation: 6/6 Nylon

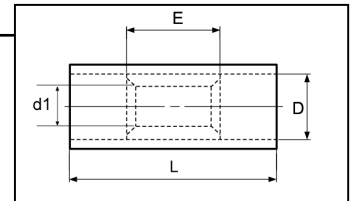

T= Material Thickness

HOFFMAN PART NO.	WIRE SIZE	WIRE COMBINATION		AMPS	DIMENSIONS (INCHES)					UL	TAPE MOUNTED REEL QTY	DIE FOR TAPE MOUNTED	HAND TOOL
		MIN	MAX		d1	L	D	E	T				
NP2216/J	22-16	2 #22	2 #18	9 - 18	.067	.630	.126	.315	0.031	Y	NA	NA	YNT2216
NP1614/J	16-14	2 #22	1 #18 + 1 #16	18 - 30	.097	.630	.154	.315	0.031	Y	NA	NA	YNT1614
NP1210/J	12-10	2 #18	2 #16	35 - 50	.134	.807	.213	.335	0.039	Y	NA	NA	YNT1210S

Flared Nylon Insulated Parallel Connectors

Material: Tin Plated Copper
Maximum Electrical Rating: 105°C, 600V
Barrel Type: Tubular
Insulation: 6/6 Nylon

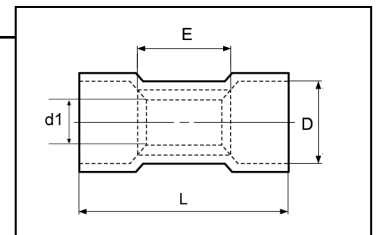

T= Material Thickness

HOFFMAN PART NO.	WIRE SIZE	WIRE COMBINATION		AMPS	DIMENSIONS (INCHES)					UL	TAPE MOUNTED REEL QTY	DIE FOR TAPE MOUNTED	HAND TOOL
		MIN	MAX		d1	L	D	E	T				
FNP2216/J	22-16	2 #22	2 #18	9 - 18	.067	.630	.157	.067	0.031	Y	NA	NA	YNT2216
FNP1614/J	16-14	2 #22	1 #18 + 1 #16	18 - 30	.091	.630	.177	.091	0.031	Y	NA	NA	YNT1614
FNP1210/J	12-10	2 #18	2 #16	35 - 50	.134	.807	.268	.134	0.039	Y	NA	NA	YNT1210S



Wire Pins

Non-Insulated Wire Pins

Material: Tin Plated Copper
Maximum Electrical Rating: 176°C, 600V
Barrel Type: Brazed Seam

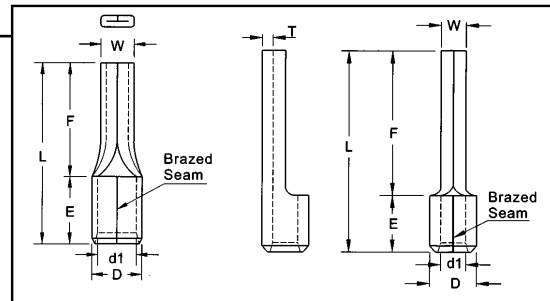

T= Material Thickness

HOFFMAN PART NO.	WIRE SIZE	AMPS	DIMENSIONS (INCHES)								UL	TAPE MOUNTED REEL QTY	DIE FOR TAPE MOUNT	HAND TOOL
			W	F	L	E	D	d1	T					
PC2216	22-16	9 - 18	0.075	0.472	0.661	0.189	0.134	0.067	0.030	Y	NA	NA	YHM228	
PC2216/J	22-16	9 - 18	0.075	0.472	0.669	0.197	0.134	0.063	0.031	N	NA	NA	YHT2210	
PC1614	16-14	18 - 30	0.075	0.512	0.701	0.189	0.161	0.091	0.031	Y	NA	NA	YHM228	
PC1614/J	16-14	18 - 30	0.075	0.472	0.669	0.197	0.161	0.091	0.031	N	NA	NA	YHT2210	
PC1210	12-10	35 - 50	0.110	0.551	0.787	0.236	0.220	0.134	0.037	Y	NA	NA	YHM228	
PC1210/J	12-10	35 - 50	0.106	0.551	0.787	0.236	0.224	0.142	0.039	N	NA	NA	YHT2210	

Vinyl Insulated Wire Pins

Material: Tin Plated Copper
Insulation: Vinyl
Maximum Electrical Rating: 75°C, 600V
Barrel Type: Butted Seam

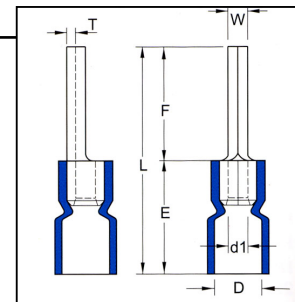

T= Material Thickness

HOFFMAN PART NO.	WIRE SIZE	AMPS	DIMENSIONS (INCHES)								UL	TAPE MOUNT REEL QTY	DIE FOR TAPE MOUNT	HAND TOOL
			W	F	L	E	D	d1	T					
FVLP2216R2	22-16	9 - 18	0.472	0.075	0.906	0.441	0.157	0.067	0.030	Y	1000	3V2216	YNM2210	
FVLP2216R2/J	22-16	9 - 18	0.472	0.075	0.827	0.354	0.157	0.067	0.031	Y	NA	NA	YNT2216	
FVLP1614	16-14	18 - 30	0.472	0.075	0.917	0.453	0.177	0.091	0.031	Y	1000	3V1614	YNM2210	
FVLP1614/J	16-14	18 - 30	0.472	0.075	0.827	0.354	0.177	0.091	0.031	Y	NA	NA	YNT1614	
FVLP1210	12-10	35 - 50	0.551	0.110	1.106	0.555	0.248	0.134	0.039	Y	500	3V1210	YNM2210	
FVLP1210/J	12-10	35 - 50	0.551	0.106	1.083	0.531	0.268	0.134	0.039	Y	NA	NA	YNT1210S	

Nylon Insulated Wire Pins

Material: Tin Plated Copper

Insulation: Nylon

Maximum Electrical Rating: 75°C, 600V

Barrel Type: Butted Seam

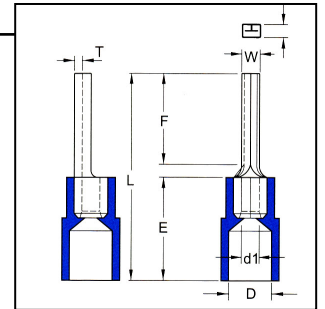

T= Material Thickness

HOFFMAN PART NO.	WIRE SIZE	AMPS	DIMENSIONS (INCHES)								UL	TAPE MOUNTED REEL QTY	DIE FOR TAPE MOUNT	HAND TOOL
			F	W	L	E	D	d1	T					
FNPC2216	22-16	9 - 18	0.472	0.075	0.898	0.433	0.157	0.067	0.031	Y	1000	3V2216		
FNPC1614	16-14	18 - 30	0.472	0.075	0.898	0.433	0.177	0.091	0.031	Y	1000	3V1614	YNM2210	
FNPC1210	12-10	35 - 50	0.551	0.110	1.063	0.512	0.252	0.134	0.039	Y	500	3V1210		



X-ON Electronics

Largest Supplier of Electrical and Electronic Components

Click to view similar products for [hoffman manufacturer](#):

Other Similar products are found below :

[A-1412CHQR](#) [CSD201610](#) [CSD20168SS](#) [CSD20206](#) [CSD20208SS](#) [CSD24168](#) [CSD36248](#) [PCU7](#) [PDS76R](#) [PRA197TP](#) [PT126](#)
[A1008CHNFSS](#) [A10106CH](#) [A10106CHFL](#) [A10106PHCW](#) [A1066JFGQRR](#) [A1210CHNF](#) [A1212SC](#) [A1412CHNFSS](#) [A161208LP](#)
[A161410CH](#) [A16H12ALP](#) [A16P14](#) [A16P16G](#) [A18P16AL](#) [A20H16BLP](#) [A20P16](#) [A24H2408SSLP](#) [Q13138PCE](#) [A404CH](#) [A606CHNF](#)
[A606NF](#) [A806SC](#) [A845JFGR](#) [A864CHQRFGW](#) [A90P36F1](#) [HJ1412HWPL2LG](#) [HJ1816HWPL2LG](#) [RHJ1210HWPL2LG](#) [AS125SS](#)
[ASE10X10X4](#) [ASE12X12X4](#) [E1PBG](#) [E2PBG](#) [E3PB](#) [LED24V15](#) [LF230VD](#) [A10106PHC](#) [A10P8SS](#) [A1210CHEMC](#)