



Address: Midas Components Ltd, Electra House, 32 Southtown Road, Great Yarmouth, Norfolk, England, NR31 ODU
Email: sales@midascomponents.co.uk
Website: www.midascomponents.co.uk
Tel: +44(0)1493 602602
Fax: +44(0)1493 665111

A large, faded version of the MIDAS logo is centered on the page. It consists of the word "MIDAS" in a light yellow font, set within a light blue oval with a wavy texture, matching the design of the logo in the top left corner.

BOOKBINDING AREA

DOC.

DATASHEET STATEMENT

1. The following icons are absolutely designed by Midas independently in 2007-SEP. They are not in common use in the LCD industry yet but just used for marking out Midas products' characteristics quickly and simply without any special meaning. Midas reserves the composing right and copyright. No one else is allowed to adopt these icons without Midas approval.
2. The ISO9001 logo used in this document is authorized by SGS (www.sgs.com). Midas had already successfully passed the strict and professional ISO9001:2000 Quality Management System Certification and got the certificate (No.: CN07/00404)
3. The technologies/techniques/crafts which denoted by the following icons are not exclusively owned by Midas, but also shared by Midas LCD strategic cooperators, however all these technologies/techniques/crafts have been finally confirmed by Midas professional engineers and QC department.
4. As the difference in test standard and test conditions, also Midas insufficient familiarity with the actual LCD using environment, all the referred information in this DATASHEET (including the icons) only have two functions:
4.1: providing quick reference when you are judging whether or not the product meets your requirements.
4.2: listing out definitely the tolerance.

SAMPLE APPROVAL document rather than consider this DATASHEET as the standard for judging whether or not the LCD meets your requirements. Once you instruct Midas to a mass-production without definite demand for providing sample before, Midas will disclaim all responsibility if the mass-production is proved not meeting with your requirements.

5. The sequence of the icons is random and doesn't indicate the importance grade.
6. Icons explanation

Midas 2006 version logo. Midas is an integrated manufacturer of flat panel display (FPD). Midas supplies TN, HTN, STN, FSTN monochrome LCD panel; COB, COG, TAB LCD module; and all kinds of LED backlight.



FAST RESPONSE TIME

This icon on the cover indicates the product is with high response speed; Otherwise not.



PROTECTION CIRCUIT

This icon on the cover indicates the product is with protection circuit; Otherwise not.



HIGH CONTRAST

This icon on the cover indicates the product is with high contrast; Otherwise not.



LONG LIFE VERSION

This icon on the cover indicates the product is long life version (over 9K hours guaranteed); Otherwise not.



WIDE VIEWING SCOPE

This icon on the cover indicates the product is with wide viewing scope; Otherwise not.



Anti UV VERSION

This icon on the cover indicates the product is against UV line. Otherwise not.



RoHS COMPLIANCE

This icon on the cover indicates the product meets ROHS requirements; Otherwise not.



OPERATION TEMPERATURE RANGE

This icon on the cover indicates the operating temperature range (X-Y).



3TIMES 100% QC EXAMINATION

This icon on the cover indicates the product has passed Midas thrice 100% QC. Otherwise not.



TWICE SELECTION OF LED MATERIALS

This icon on the cover indicates the LED had passed Midas twice strict selection which promises the product's identical color and brightness; Otherwise not.



Vcm = 3.0V

This icon on the cover indicates the product can work at 3.0V exactly; otherwise not.



N SERIES TECHNOLOGY (2008 developed)

New structure, new craft, new technology and new materials inside both LCD module and LCD panel to improve the "RainBow"

Midas LCD Part Number System

MC COG 132033 A * 6 W * * - S N T L W * *
1 2 3 4 5 6 7 8 9 - 10 11 12 13 14 15 16

- 1 = **MC:** Midas Components
- 2 = **Blank:** COB (chip on board) **COG:** chip on glass
- 3 = **No of dots** (e.g. 240064 = 240 x 64 dots) (e.g. 21605 = 2 x 16 5mm C.H.)
- 4 = **Series**
- 5 = **Series Variant:** A to Z
- 6 = **3:** 3 o'clock **6:** 6 o'clock **9:** 9 o'clock **12:** 12 o'clock
- 7 = **S:** Normal (0 to + 50 deg C) **W:** Wide temp. (-20 to + 70 deg C) **X:** Extended temp (-30 + 80 Deg C)
- 8 = **Character Set**

Blank: Standard (English/Japanese)
C: Chinese Simplified (Graphic Displays only)
CB: Chinese Big 5 (Graphic Displays only)
H: Hebrew
K: European (std) (English/German/French/Greek)
L: English/Japanese (special)
M: European (English/Scandinavian)
R: Cyrillic
W: European (English/Greek)
U: European (English/Scandinavian/Icelandic)

9 = **Bezel Height** (where applicable / available)

	Top of Bezel to Top of PCB	Common (via pins 1 and 2)	Array or Edge Lit
Blank	9.5mm / not applicable	Common	Array
2	8.9 mm	Common	Array
3	7.8 mm	Separate	Array
4	7.8 mm	Common	Array
5	9.5 mm	Separate	Array
6	7 mm	Common	Array
7	7 mm	Separate	Array
8	6.4 mm	Common	Edge
9	6.4 mm	Separate	Edge
A	5.5 mm	Common	Edge
B	5.5 mm	Separate	Edge

- 10 = **T:** TN **S:** STN **B:** STN Blue **G:** STN Grey **F:** FSTN **F2:** FFSTN
- 11 = **P:** Positive **N:** Negative
- 12 = **R:** Reflective **M:** Transmissive **T:** Transflective
- 13 = **Backlight:** **Blank:** Reflective **L:** LED
- 14 = **Backlight Colour:** **Y:** Yellow-Green **W:** White **B:** Blue **R:** Red **A:** Amber **O:** Orange **G:** Green **RGB:** R.G.B.
- 15 = **Driver Chip:** **Blank:** Standard **I:** I²C
- 16 = **Voltage Variant:** e.g. **3** = 3v

BOOKBINDING AREA

	STANDARD DOC.	REVISION RECORD	PAGE	1/16
--	--------------------------	------------------------	-------------	-------------

NO.	DATE	DESCRIPTION	ITEM	PAGE	APPROVED
1	2011.02	INITIAL ISSUED	ALL	ALL	

MIDAS

BOOKBINDING AREA

	STANDARD DOC.	CONTENTS	PAGE	2/16
--	--------------------------	-----------------	-------------	-------------

1.	GENERAL SPECIFICATIONS -----	Page 3
2.	MECHANICAL SPECIFICATIONS -----	Page 3
3.	ABSOLUTE MAXIMUM RATINGS -----	Page 3
4.	ELECTRONICAL CHARACTERISTIC -----	Page 3
5.	OPTICAL CHARACTERISTICS -----	Page 4
6.	DC CHARACTERISTICS -----	Page 5
7.	AC CHARACTERISTICS -----	Page 5
8.	EXTERNAL DIMENSION-----	Page 7
9.	PIN ASSIGNMENT -----	Page 8
10.	BLOCK DIAGRAM-----	Page 8
11.	POWER SUPPLY -----	Page 8
12.	FUNCTIONAL DESCRIPTION -----	Page 9
13.	INSTRUCTION -----	Page 12
14.	DESCRIPTION OF COMMAND -----	Page 13
15.	APPLICATION EXAMPLE -----	Page 15
16.	PACKING DETAIL -----	Page 16

BOOKBINDING AREA

	PRODUCT SPEC.	MODE NO.	PAGE	3/16
		MC128064C6W-FPTLW		

1. GENERAL SPECIFICATIONS

ITEM	NOMINAL DIMENSIONS / AVAILABLE OPTIONS
DISPLAY FORMAT	128 X 64 DOT MATRIX
LCD PANEL OPTIONS	FSTN (Silver-gray color)
POLARIZER OPTIONS	Positive, Transflective
BACKLIGHT OPTIONS	Edge type LED backlight (White color)
VIEWING DIRECTION OPTIONS	6:00 (Bottom)
TEMPERATURE RANGE OPTIONS	Wide temp. range (-20°C ~ 70°C)
CONTROLLER IC	NT7107C+NT7108C
NEGATIVE IC	Built in
DISPLAY DUTY	1/64
DRIVING BIAS	1/9

2. MECHANICAL SPECIFICATIONS

OVERALL SIZE	LED backlight version :			75.0 x 52.7 x max 13.0	mm
VIEWING AREA	60.0W x 32.5H	mm	HOLE-HOLE	70.0W x 49.7H	mm
DOT SIZE	0.39W x 0.39H	mm	DOT PITCH	0.04W x 0.04H	mm
WEIGHT (EL BKL)	---	g	WEIGHT (LED BKL)	65.0	g

3. ABSOLUTE MAXIMUM RATINGS

ITEM	SYMBOL	CONDITION	MIN	MAX	UNIT
POWER SUPPLY (LOGIC)	Vdd	25°C	-0.3	7.0	V
POWER SUPPLY (LCD)	V0	25°C	Vdd -19.0	Vdd +0.3	V
INPUT VOLTAGE	Vin	25°C	-0.3	Vdd +0.3	V
OPERATING TEMPERATURE	Vopr	---	-20	70	°C
STORAGE TEMPERATURE	Vstg	---	-30	80	°C

4. ELECTRONICAL CHARACTERISTIC*

ITEM	SYMBOL	CONDITION	STANDARD			UNIT
			MIN	TYP	MAX	
Input voltage	Vdd	+5V	2.7	5.0	5.5	V
Supply current	Idd	Vdd=5V	---	2.1	---	mA
Recommended LCD driving voltage for normal temp. Version module	Vdd - V0	-20°C	8.20	---	9.00	V
		0°C	8.10	---	8.70	
		25°C	8.00	8.30	8.60	
		50°C	7.80	---	8.50	
		70°C	7.65	---	8.30	
LED forward voltage	Vf	25°C	2.9	---	3.4	V
LED forward current	If	25°C	---	30	40	mA
LED reverse Current	Ir	25°C	---	10	---	µA
LED color range	X coordinate	25°C If = 30mA	0.25	---	0.28	---
	Y coordinate	25°C If = 30mA	0.26	---	0.29	---
LED illuminance (Without LCD)	Lv	25°C If = 30mA	120	---	190	cd/m ²
LED life time	---	25°C If = 30mA	9K**	---	---	Hours

* The above data are for reference only.

** The warranty period of FORDATA LCD module is 1YEAR counted from the date shown on the label of products.

** If you wanted to drive the LED BKL uninterruptedly exceed 12hours/day, you are not suggested this version

	PRODUCT SPEC.	MODE NO.	PAGE	4/16
		MC128064C6W-FPTLW		

5. OPTICAL CHARACTERISTIC

FOR TN TYPE LCD MODULE (TA=25 °C, Vdd=5.0V ± 0.25V)						
ITEM	SYMBOL	CONDITION	MIN	TYP	MAX	UNIT
VIEWING ANGLE	$\Phi 2 - \Phi 1$	K=4	30	---	---	deg
	θ		25			
CONTRAST RATIO	K	---	---	2	---	---
RESPONSE TIME(RISE)	TR	---	---	120	150	ms
RESPONSE TIME(FALL)	TF	---	---	120	150	ms

FOR STN TYPE LCD MODULE (TA=25 °C, Vdd=5.0V ± 0.25V)						
ITEM	SYMBOL	CONDITION	MIN	TYP	MAX	UNIT
VIEWING ANGLE	$\Phi 2 - \Phi 1$	K=4	40	---	---	deg
	θ		60			
CONTRAST RATIO	K	---	---	6	---	---
RESPONSE TIME(RISE)	TR	---	---	150	250	ms
RESPONSE TIME(FALL)	TF	---	---	150	250	ms

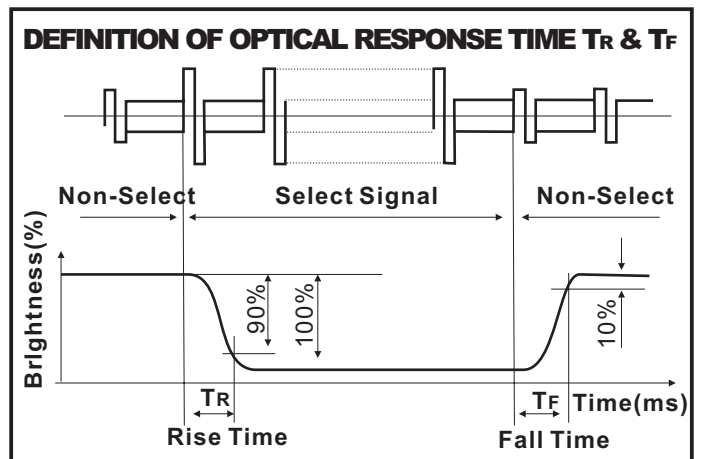
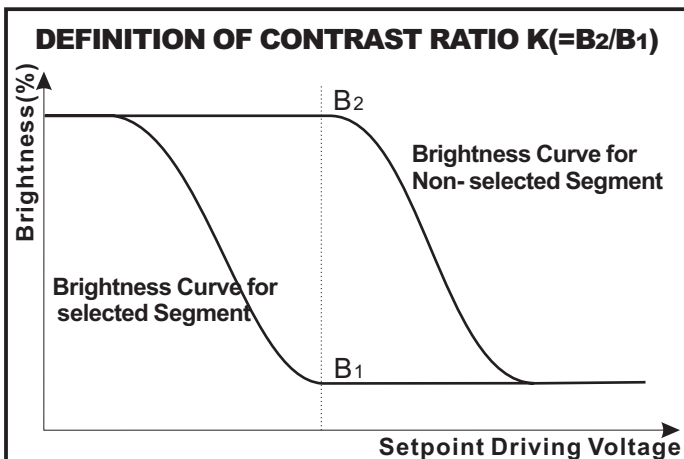
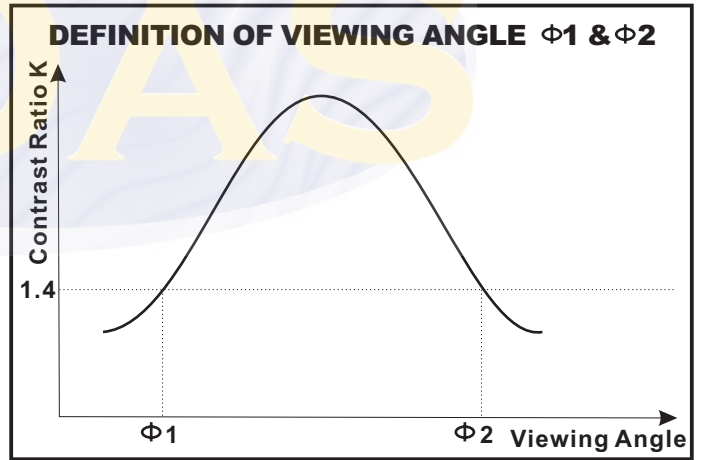
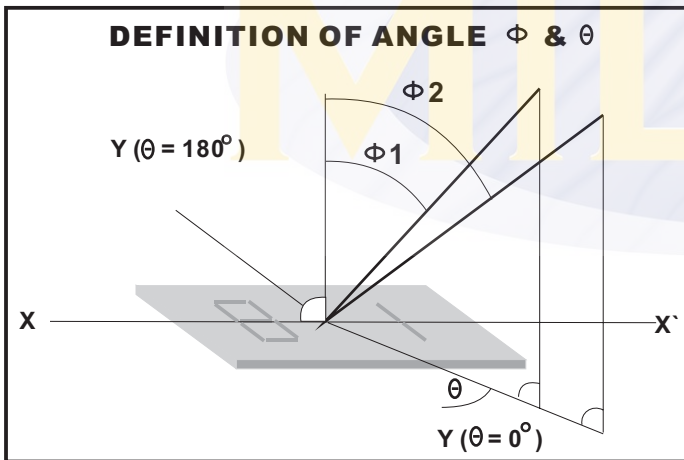

	PRODUCT SPEC.	MODE NO.	PAGE	5/16
		MC128064C6W-FPTLW		

6. DC CHARACTERISTIC

(Unless otherwise stated, VDD= +5V ± 10%, VSS=0V, Ta=25°C)

Parameter	Symbol	Condition	Min.	Typ.	Max.	Unit
High Level Input Voltage	VIH1	---	0.7VDD	---	VDD	V
	VIH2	---	0.7VDD	---	VDD	V
Low Level Input Voltage	VIL1	---	0	---	0.3VDD	V
	VIL2	---	0	---	0.8	V
High Level Output Voltage	VOH	IOH = - 200 μ A	2.4	---	---	V
Low Level Output Voltage	VOL	IOL = 1.6 mA	---	---	0.4	V
Input Leakage Current	ILKG	VIN = VDD to VSS	-1.0	---	1.0	μ A
Three-State (OFF) Input Current	ITSL	VIN = VDD to VSS	-5.0	---	5.0	μ A
Operating Current	IDD1	During Display	---	---	100	μ A
	IDD2	During Access, Access Cycle = 1MHz	---	---	500	μ A

7. AC CHARACTERISTIC

Characteristic	Symbol	Min	Typ	Max	Unit
E Cycle	t _c	1000	—	—	ns
E High Level Width	t _{WH}	450	—	—	ns
E Low Level Width	t _{WL}	450	—	—	ns
E Rise Time	t _R	—	—	25	ns
E Fall Time	t _F	—	—	25	ns
Address Setup Time	t _{ASU}	140	—	—	ns
Address Hold Time	t _{AH}	10	—	—	ns
Data Setup Time	t _{DSU}	200	—	—	ns
Data Delay Time	t _D	—	—	320	ns
Data Hold Time (Write)	t _{DHW}	10	—	—	ns
Data Hold Time (Read)	t _{DHR}	20	—	—	ns

7.1 WRITE MODE TIMING DIAGRAM

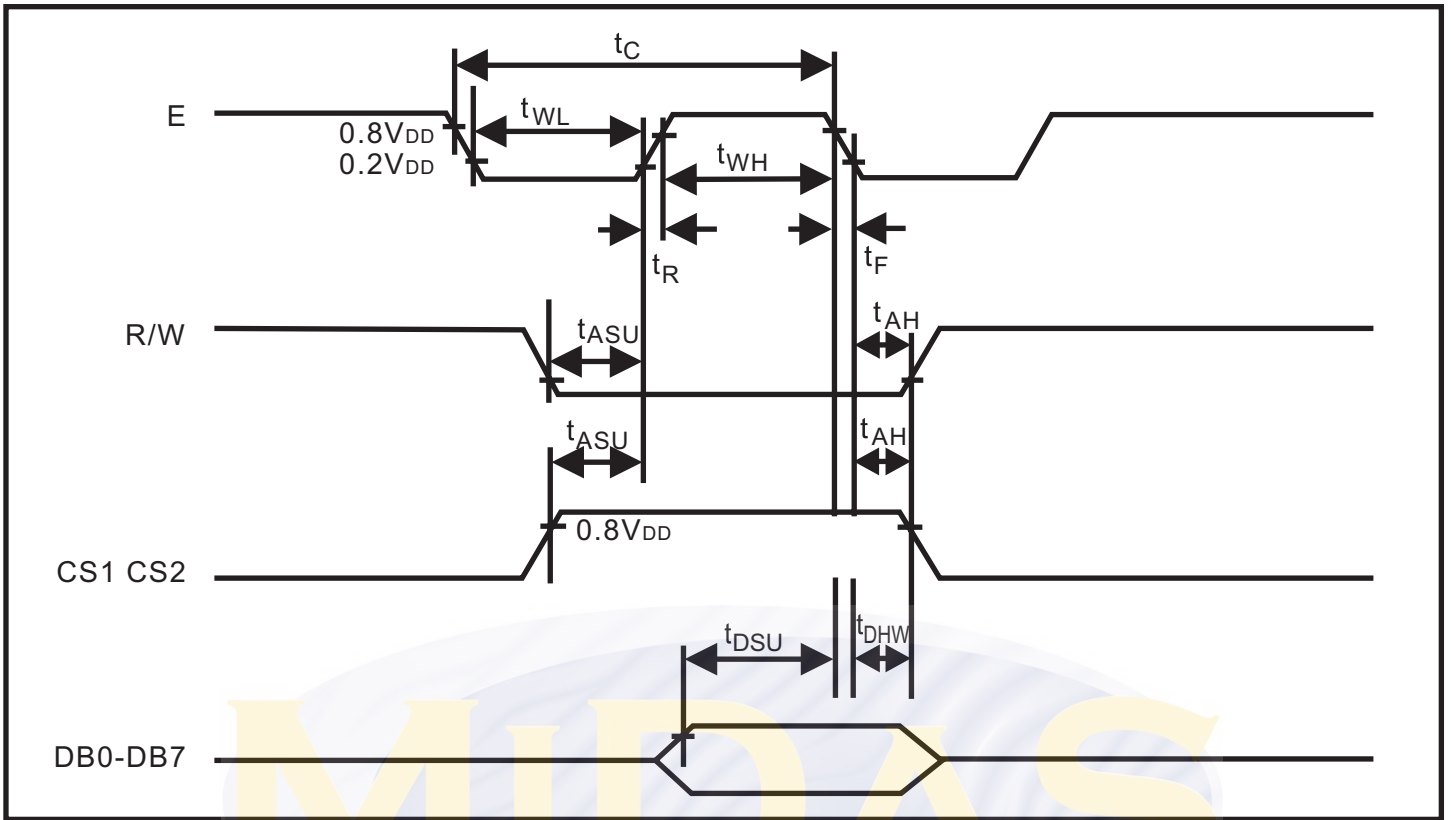

7.2 READ MODE TIMING DIAGRAM

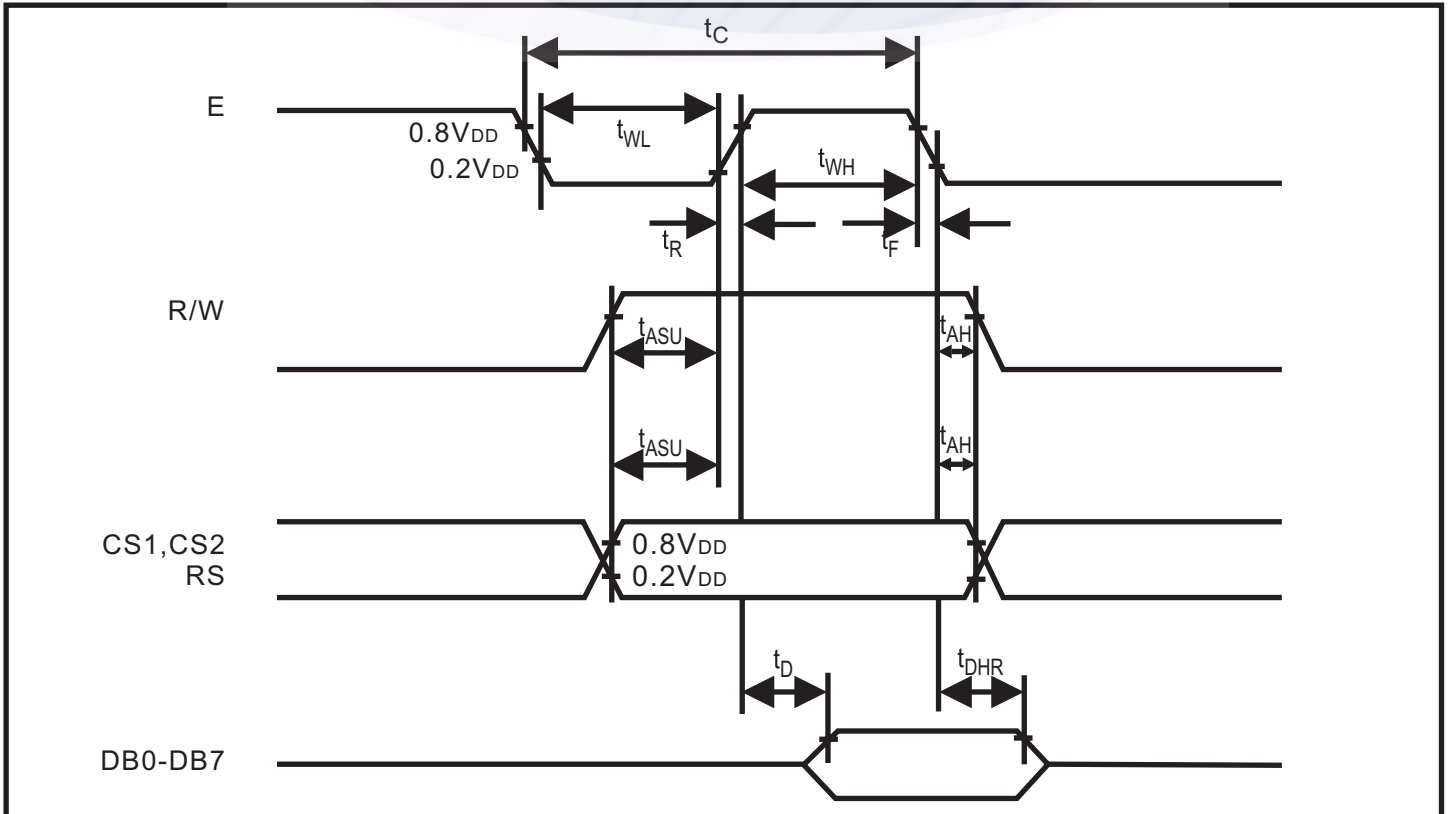

8.EXTERNAL DIMENSIONS

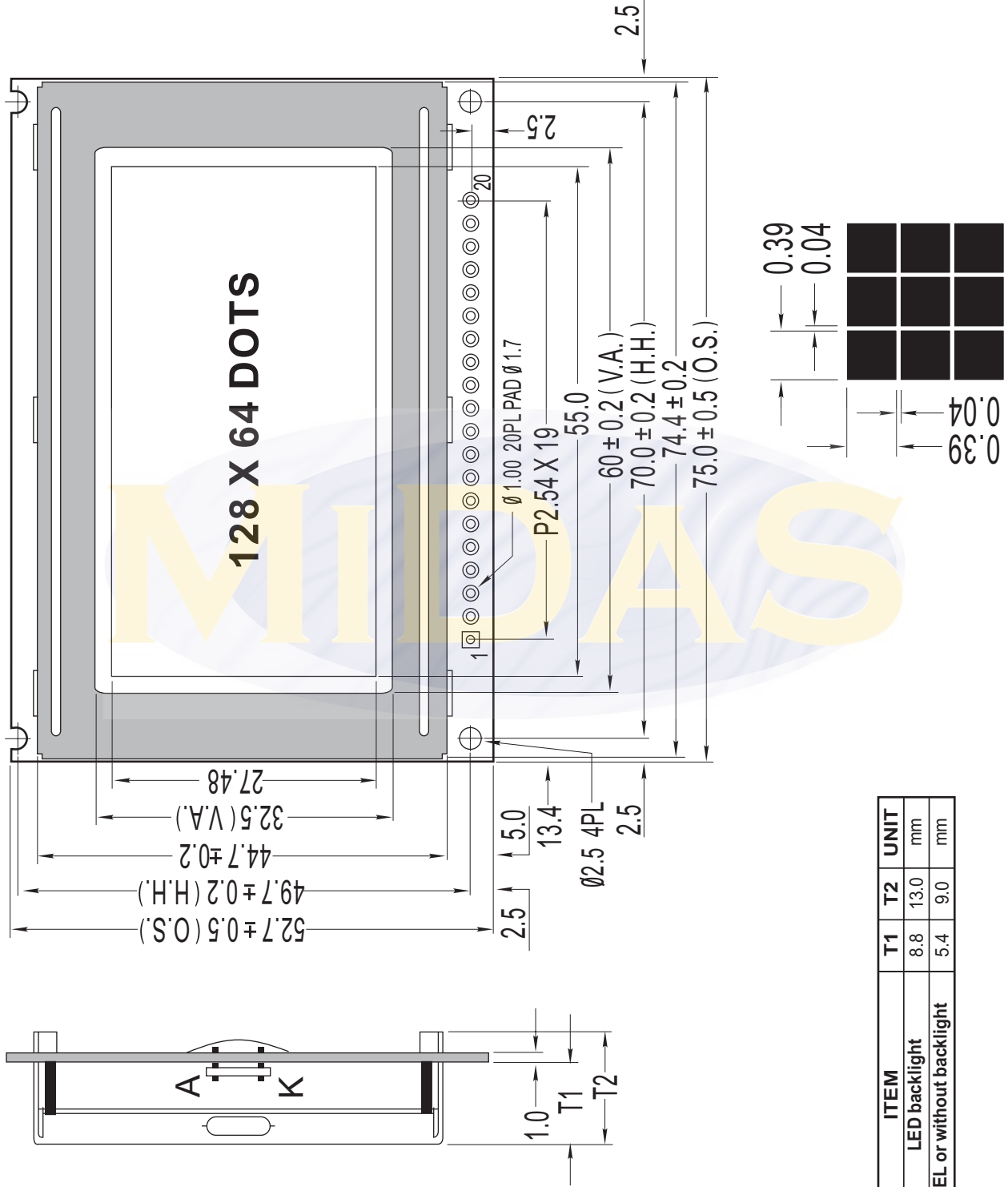

	PRODUCT SPEC.	MODE NO.	PAGE	8/16
		MC128064C6W-FPTLW		

9. PIN ASSIGNMENT

PIN NO.	SYMBOL	FUNCTION	REMARK
1	Vdd	Power Supply	+5V
2	Vss		0V
3	V0		Contrast Adjust
4	DB0	Data Bit 0	
5	DB1	Data Bit 1	
6	DB2	Data Bit 2	
7	DB3	Data Bit 3	
8	DB4	Data Bit 4	
9	DB5	Data Bit 5	
10	DB6	Data Bit 6	
11	DB7	Data Bit 7	
12	CS1	When CS1=H,CS2=L, select U2	
13	CS2	When CS1=L,CS2=H, select U3	
14	RSTB	Reset signal	
15	R/W	Read / Write	
16	D/I	H/L H: Data, L: Instruction code	
17	E	Chip Enable signal	
18	Vee	Negative voltage output	
19	LED+	Anode of LED Unit	5.0V
20	LED-	Cathode of LED Unit	0V

10. BLOCK DIAGRAM

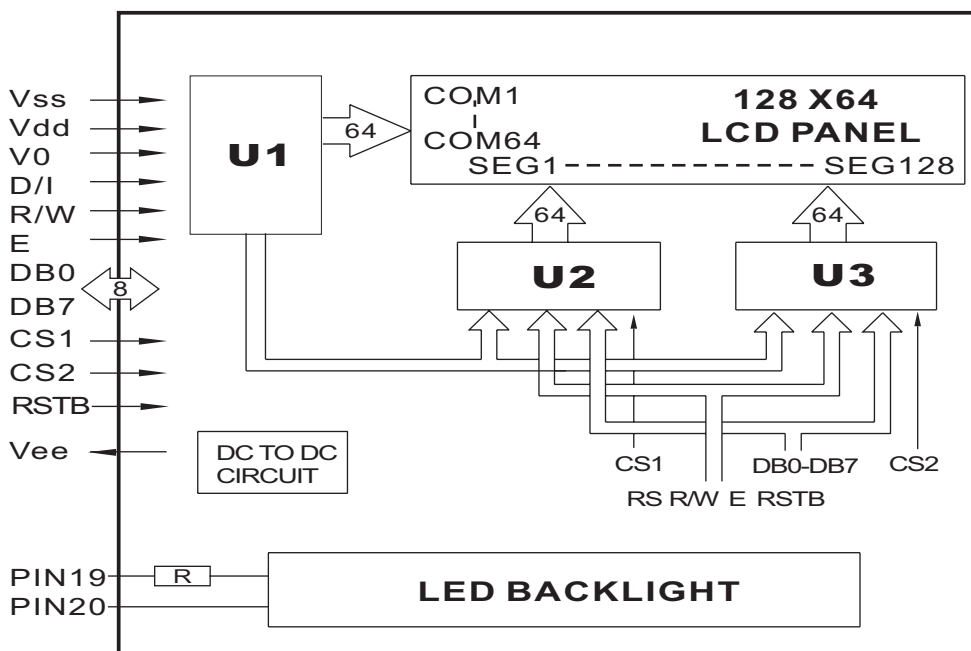

11. POWER SUPPLY

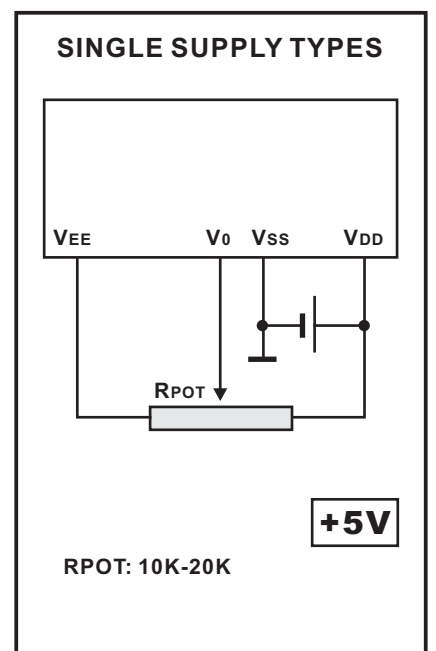

	PRODUCT SPEC.	MODE NO.	PAGE	9/16
		MC128064C6W-FPTLW		

12. FUNCTIONAL DESCRIPTION

12.1 RESET

The system can be initialized by setting the RSTB to LOW when turning the power ON or by instruction from the MPU. When the RSTB is set to LOW, the following condition occurs:

1. The Display is turned OFF.
2. The Display Start Line register is set to 0 (Z-Address 0).

No instructions except the status read can be executed when the RSTB is LOW. This means that in order to execute other instructions, the RSTB must be cleared by setting DB4 to 0 and the DB7 set to 0 by status read instruction.

The table below shows the power supply initial conditions.

Parameter	Symbol	Min.	Typ.	Max.	Unit
Reset Time	t_{RS}	1.0	-	-	μS
Rise Time	t_R	-	-	200	nS

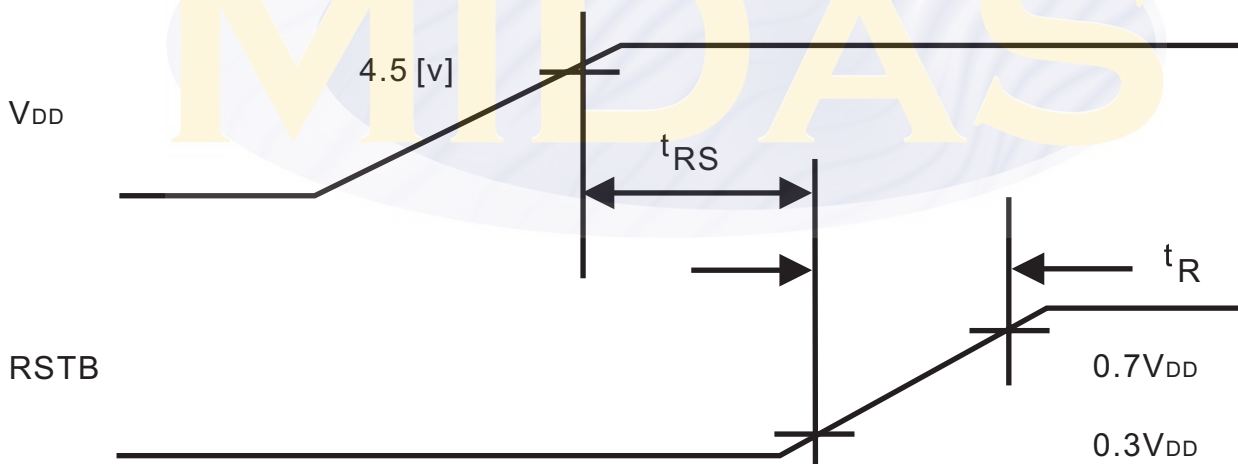

	PRODUCT SPEC.	MODE NO.	PAGE	10/16
		MC128064C6W-FPTLW		

12.2 BUSY FLAG

The busy flag (DB7) is used to determine whether Nt7108 is operating or not. When the busy flag is HIGH, internal operation is taking place. When the busy flag is LOW, Nt7108 can accept data or instructions. The busy check diagram is shown below.

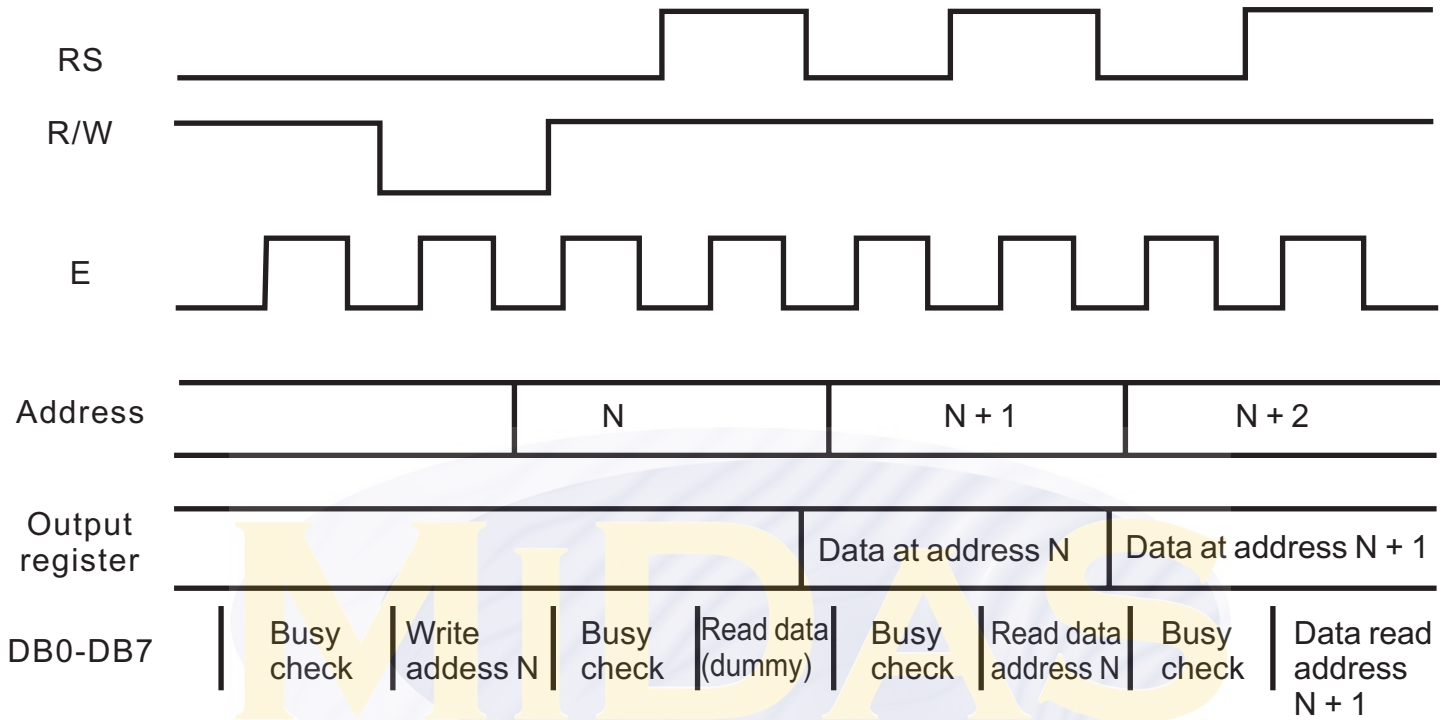

The busy flag diagram is shown below.

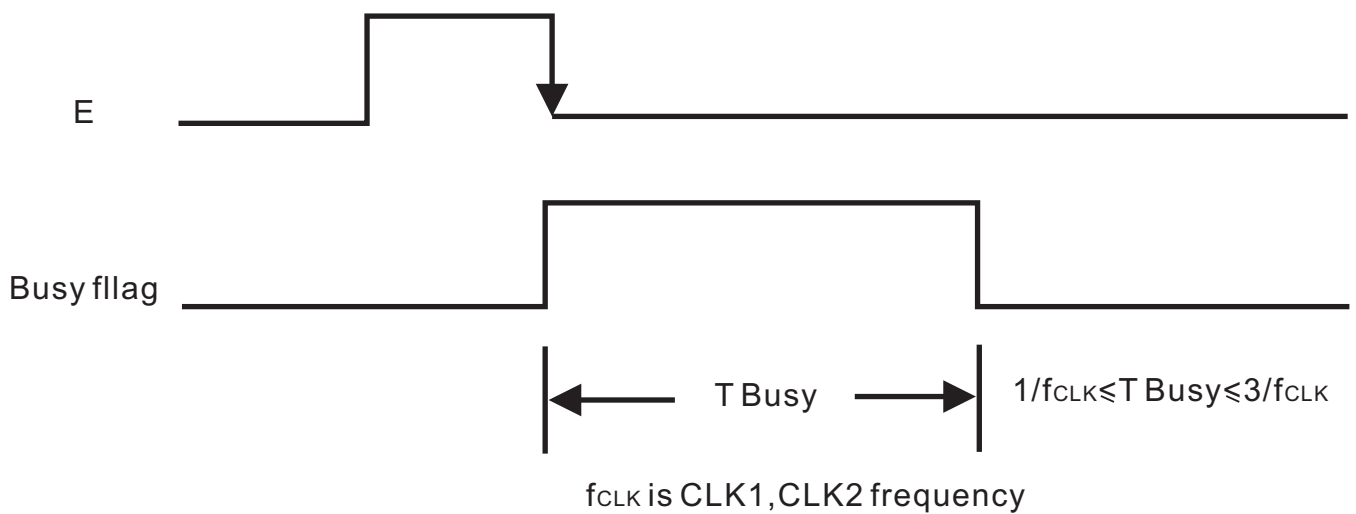

	PRODUCT SPEC.	MODE NO.	PAGE 11/16
		MC128064C6W-FPTLW	

12.3 RELATION BETWEEN DISPLAY PATTERN AND DRIVERS

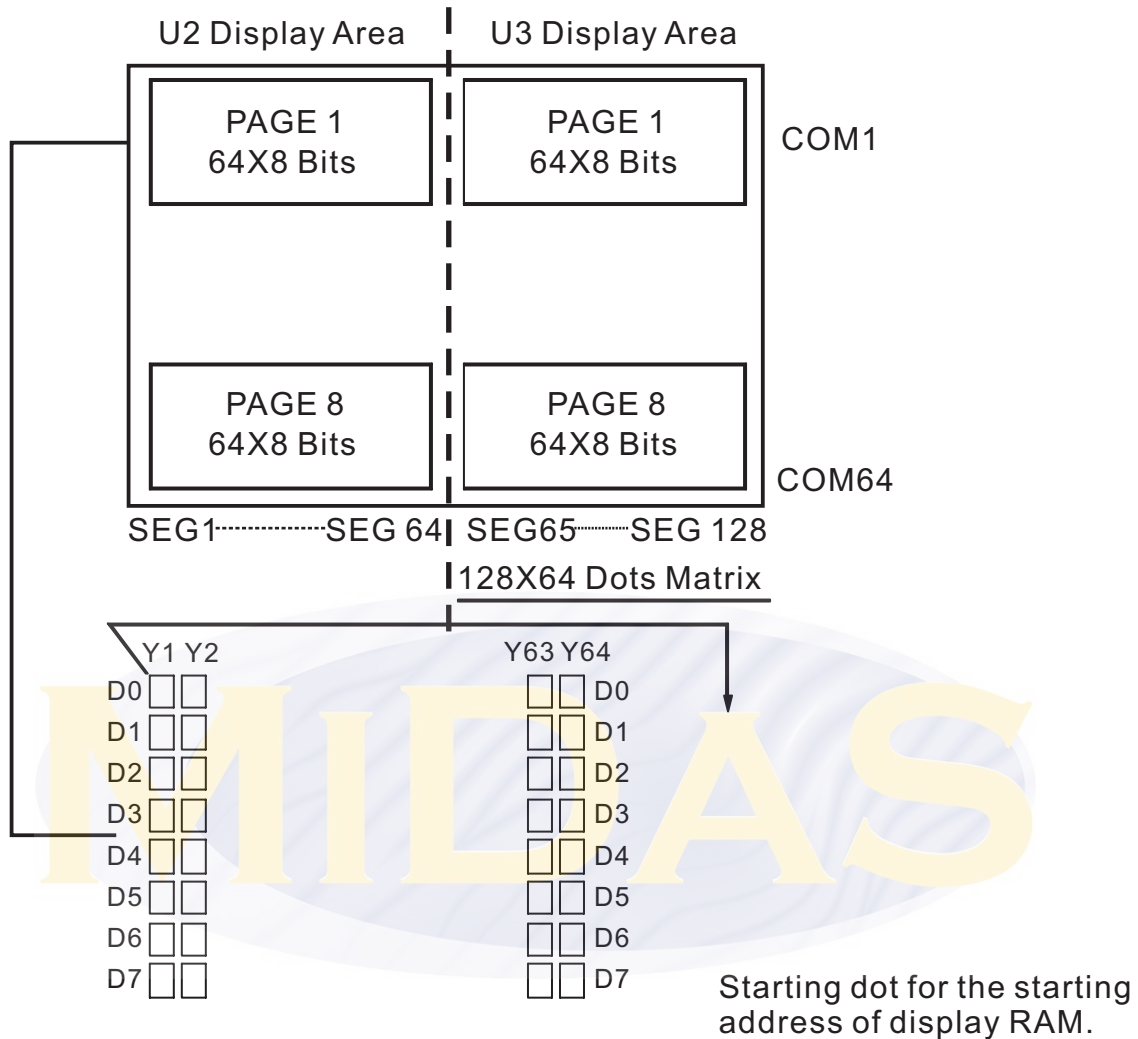

Each segment driver has 8 pages RAM, and each page has 64x8 bits RAM. D0~D7 are 8 bits transmitted data, where D0 is LSB and D7 is MSB.

12.4 DISPLAY DATA RAM

The Display Data RAM is used to store the display data for the liquid crystal display. Write data 1 is indicates an ON State of the LCDs dot matrix while the OFF State is written as 0. ADC Signal can control the Display Data RAM and the segment output. Please refer to the table below.

ADC *	Display Data
H	Y-Address 0:S1 to Y-Address 63:S64

BOOKBINDING AREA

	PRODUCT SPEC.	MODE NO.		PAGE	12/16
		MC128064C6W-FPTLW			

13. INSTRUCTION

Instruction	RS	R/W	DB7	DB6	DB5	DB4	DB3	DB2	DB1	DB0	Function	
Display ON/OFF	L	L	L	L	H	H	H	H	H	L/H	Controls the display on or off. Internal status and display RAM data is not affected. L:OFF H:ON	
Set address (Y address)	L	L	L	H	Y address (0~63)						Sets the Y address in the Y address counter.	
Set Page (X address)	L	L	H	L	H	H	H	Page (0~7)			Sets the X address at the X address register.	
Display Start Line (Z address)	L	L	H	H	Display start line (0~63)						Indicates the display data RAM displayed at the top of the screen.	
Status Read	L	H	B U S Y	L	O N / O F F	R E S E T	L	L	L	L	BUSY L:Ready H:In operation ON/OFF L:Display ON H:Display OFF RESET L:Normal H:Reset	
Write Display Data	H	L	Write Data									Writes data (DB0:7) into display data RAM,After writing instruction,Y address is increased by 1 automatically.
Read Display Data	H	H	Read Data									Reads data (DB0:7) from display data RAM to the data bus.

	PRODUCT SPEC.	MODE NO.	PAGE	13/16
		MC128064C6W-FPTLW		

14. DESCRIPTION OF COMMAND

Display On/Off

RS	R/W	DB7	DB6	DB5	DB4	DB3	DB2	DB1	DB0
0	0	0	0	1	1	1	1	1	D

The display data appears when D is 1 and disappears when D is 0.

Though the data is not on the screen with D=0, it remains in the display data RAM.

Therefore, you can make it appear by changing D=0 into D=1.

Set Address(Y Address)

RS	R/W	DB7	DB6	DB5	DB4	DB3	DB2	DB1	DB0
0	0	0	1	AC5	AC4	AC3	AC2	AC1	AC0

Y address (AC0-AC5) of the display data RAM is set in the Y address counter.

An address is set by instruction and increased by 1 automatically by read or write operations of display data.

Set Page(X Address)

RS	R/W	DB7	DB6	DB5	DB4	DB3	DB2	DB1	DB0
0	0	1	0	1	1	1	AC2	AC1	AC0

X address (AC0-AC2) of the display data RAM is set in the X address register.

Writing or reading to or from MPU is executed in this specified page until the next page is set.

Display Start Line(Z Address)

RS	R/W	DB7	DB6	DB5	DB4	DB3	DB2	DB1	DB0
0	0	1	1	AC5	AC4	AC3	AC2	AC1	AC0

Z address (AC0-AC5) of the display data RAM is set in the display start line register and displayed at the top of the screen.

When the display duty cycle is 1/64 or others(1/32-1/64), the data of total line number of LCD screen, from the line specified by display start line instruction, is displayed.

	PRODUCT SPEC.	MODE NO.	PAGE	14/16
		MC128064C6W-FPTLW		

Status Read

RS	R/W	DB7	DB6	DB5	DB4	DB3	DB2	DB1	DB0
0	1	BUSY	0	ON/OFF	RESET	0	0	0	0

● **BUSY**

When BUSY is 1, the Chip is executing internal operation and no instructions are accepted.
When BUSY is 0, the Chip is ready to accept any instructions.

● **ON/OFF**

When ON/OFF is 1, the display is off.
When ON/OFF is 0, the display is on.

● **RESET**

When RESET is 1, the system is being initialized.
In this condition, no instructions except status read can be accepted.
When RESET is 0, initializing has finished and the system is in the usual operation condition.

Write Display Data

RS	R/W	DB7	DB6	DB5	DB4	DB3	DB2	DB1	DB0
1	0	D7	D6	D5	D4	D3	D2	D1	D0

Writes data (D0-D7) into the display data RAM.
After writing instruction, Y address is increased by 1 automatically.

Read Display Data

RS	R/W	DB7	DB6	DB5	DB4	DB3	DB2	DB1	DB0
1	1	D7	D6	D5	D4	D3	D2	D1	D0

Reads data (D0-D7) from the display data RAM.
After reading instruction, Y address is increased by 1 automatically.

	PRODUCT SPEC.	MODE NO.	PAGE	15/16
		MC128064C6W-FPTLW		

15. APPLICATION EXAMPLE

Application Flowchart

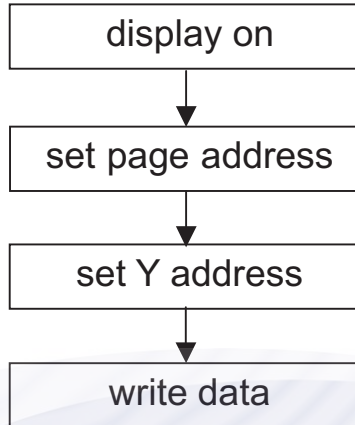

MIDAS

Application Circuit

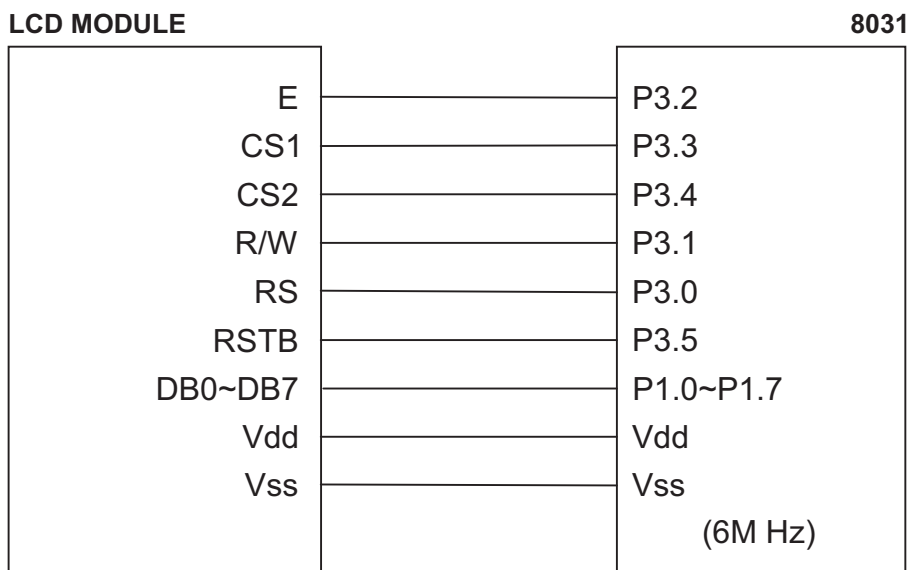

BOOKBINDING AREA

	PRODUCT SPEC.	MODE NO.	PAGE 16/16
		MC128064C6W-FPTLW	

16. PACKING DETAIL

WITH LED BKL	WITHOUT LED BKL
30 PCS/BOX	30 PCS/BOX
8 BOXES/CARTON	8 BOXES/CARTON
240 PCS/CARTON	240 PCS/CARTON
19.00 KGS/CTN(G.W.)	17.00 KGS/CTN(G.W.)
0.07 M ³ /CARTON	0.07 M ³ /CARTON

NOTE
1. The weight is estimated for reference only.
2. Packing detail may be changed without notice.

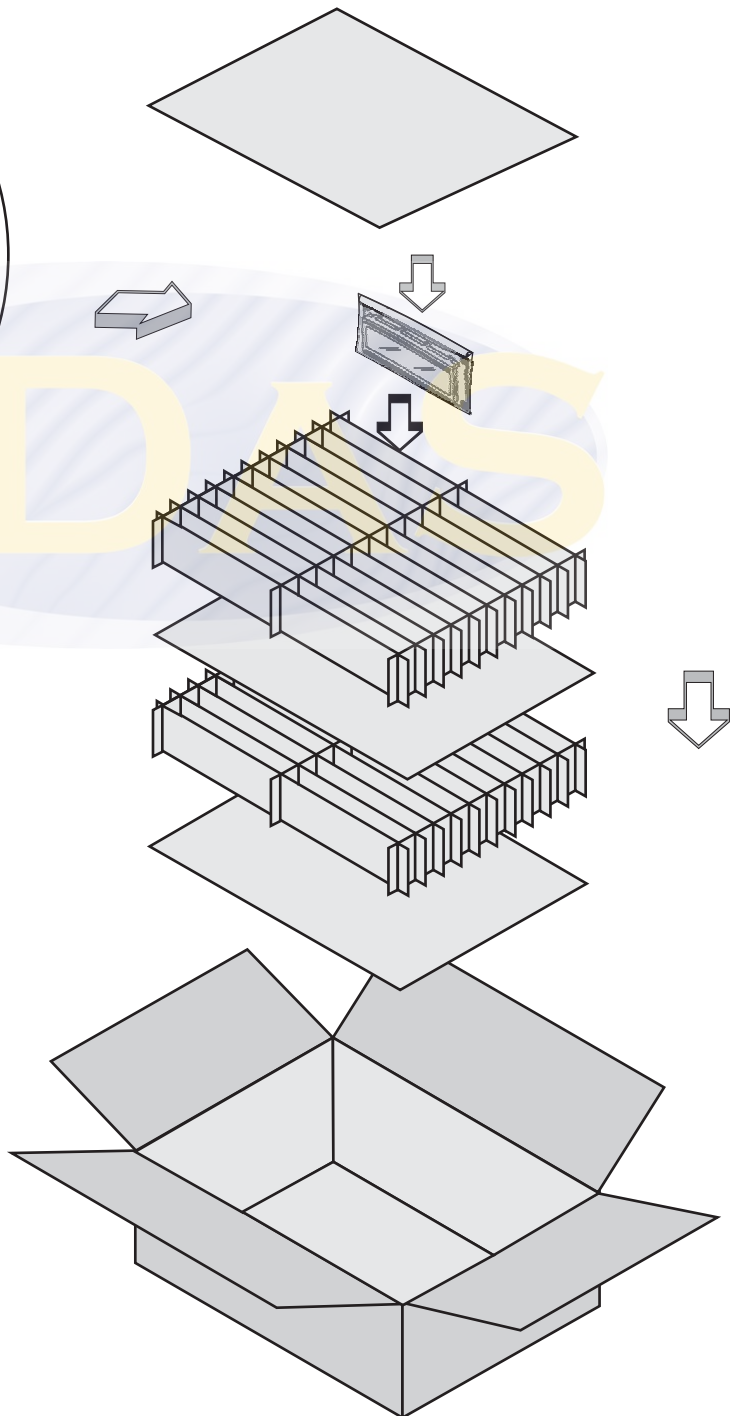
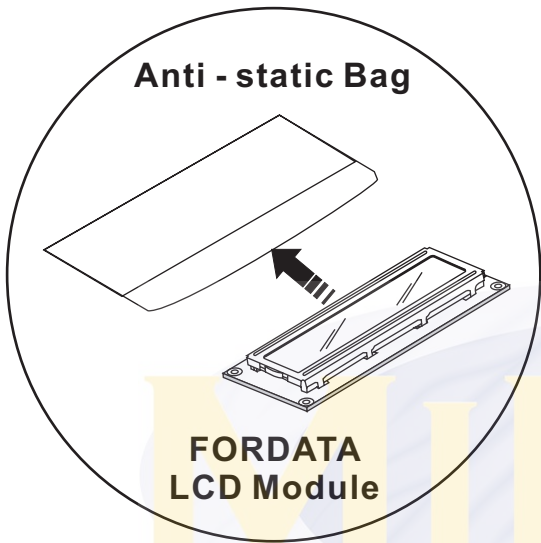

BOX

CARTON

X-ON Electronics

Largest Supplier of Electrical and Electronic Components

Click to view similar products for [midas](#) manufacturer:

Other Similar products are found below :

[MCT070LA12W1024600LML](#) [MCOT128064BY-WM](#) [MCOB21609AV-EWP](#) [MC42004A6W-SPTLY](#) [MC22008B6W-SPR](#)
[MCT035G12W320240LML](#) [MC11605A6WR-SPTLY-V2](#) [MC21605H6W-BNMLW-V2](#) [MCOT048064A1V-YI](#)
[MCT101E0CW1280800LMLIPS](#) [MCT104A0W1024768LML](#) [MCT070Z0W800480LML](#) [MCT0144C6W128128PML](#) [MCIB-16-LVDS-](#)
[CABLE](#) [MC41605A6W-FPTLA-V2](#) [MCOT128064UA1V-WM](#) [MCT101E0TW1280800LMLIPS](#) [MCT150B0W1024768LML](#)
[MCT050HDMI-A-RTP](#) [MCT050HDMI-A-CTP](#) [MCT070Z0TW1W800480LML](#) [MCT050ACA0CW800480LML](#) [MC42008A6W-SPTLY](#)
[MC42005A12W-VNMLY](#) [MC42005A12W-VNMLG](#) [MCT052A6W480128LML](#) [MC21605A6WK-BNMLW-V2](#) [MCOT256064A1A-BM](#)
[MCOT22005A1V-EYM](#) [MC20805A12W-VNMLG](#) [MC21605B6WD-BNMLW-V2](#) [MC22405A6WK-BNMLW-V2](#) [MC41605A6WK-](#)
[FPTLW-V2](#) [MCT101HDMI-A-RTP](#) [MCT024L6W240320PML](#) [MCCOG21605D6W-FPTLWI](#) [MC21605A6WD-SPTLY-V2](#)
[MC22005A6WK-BNMLW-V2](#) [MC24005AA6W9-BNMLW-V2](#) [MC42004A6WK-SPTLY-V2](#) [MC11609A6W-SPTLY-V2](#)
[MCOT064048A1V-YM](#) [MCOT128064BY-BM](#) [MCCOG128064B12W-FPTLRGB](#) [MC11609A6W-SPR-V2](#) [MC21605H6WK-BNMLW-V2](#)
[MCOT128064E1V-BM](#) [MCT070HDMI-B-RTP](#) [MDT5000C](#) [MCCOG42005A6W-BNMLWI](#)