

# MC10ELT22, MC100ELT22

## 5.0 V Dual TTL to Differential PECL Translator

The MC10ELT/100ELT22 is a dual TTL to differential PECL translator. Because PECL (Positive ECL) levels are used only +5 V and ground are required. The small outline 8-lead package and the low skew, dual gate design of the ELT22 makes it ideal for applications which require the translation of a clock and a data signal.

### Features

- 1.2 ns Typical Propagation Delay
- < 300 ps Typical Output to Output Skew
- PNP TTL Inputs for Minimal Loading
- Flow Through Pinouts
- Operating Range:  $V_{CC} = 4.75 \text{ V}$  to  $5.25 \text{ V}$  with  $GND = 0 \text{ V}$
- No Internal Input Pulldown Resistors
- Pb-Free Packages are Available



**ON Semiconductor**<sup>®</sup>

<http://onsemi.com>

### MARKING DIAGRAMS\*

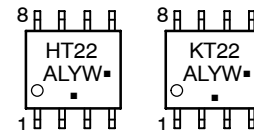
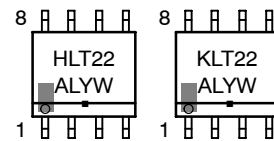

H = MC10  
K = MC100  
A = Assembly Location  
L = Wafer Lot  
Y = Year  
W = Work Week  
■ = Pb-Free Package

(Note: Microdot may be in either location)

\*For additional information, see Application Note AND8002/D.

### ORDERING INFORMATION

See detailed ordering and shipping information in the package dimensions section on page 5 of this data sheet.

# MC10ELT22, MC100ELT22

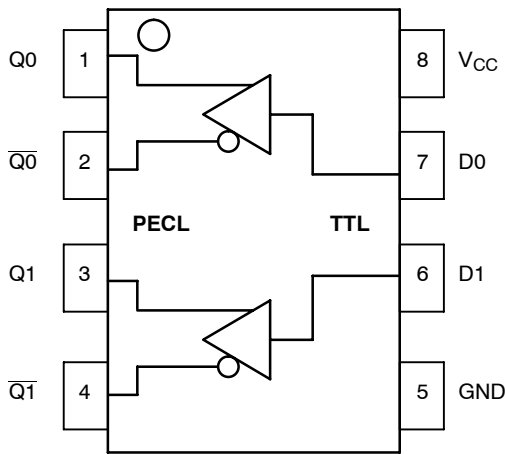

**Table 1. PIN DESCRIPTION**

Pin	Function
Qn, $\overline{Qn}$	PECL Differential Outputs*
Dn	TTL Inputs
VCC	Positive Supply
GND	Ground

\*Output state undetermined when inputs are open.

**Figure 1. Logic Diagram and Pinout Assignment**

**Table 2. ATTRIBUTES**

Characteristics	Value
Internal Input Pulldown Resistor	N/A
Internal Input Pullup Resistor	N/A
ESD Protection	Human Body Model Machine Model
	> 2 kV > 200 V
Moisture Sensitivity, Indefinite Time Out of Drypack (Note 1)	Level 1
Flammability Rating	Oxygen Index: 28 to 34
	UL 94 V-0 @ 0.125 in
Transistor Count	51
Meets or exceeds JEDEC Spec EIA/JESD78 IC Latchup Test	

1. For additional information, see Application Note AND8003/D.

# MC10ELT22, MC100ELT22

**Table 3. MAXIMUM RATINGS**

Symbol	Parameter	Condition 1	Condition 2	Rating	Units
V <sub>CC</sub>	Positive Power Supply	GND = 0 V		7	V
V <sub>IN</sub>	Input Voltage	GND = 0 V		$GND + 0.025 \leq V_I \leq V_{CC} - 0.025$	V
I <sub>out</sub>	Output Current	Continuous Surge		50 100	mA mA
T <sub>A</sub>	Operating Temperature Range			-40 to +85	°C
T <sub>stg</sub>	Storage Temperature Range			-65 to +150	°C
θ <sub>JA</sub>	Thermal Resistance (Junction-to-Ambient)	0 lfpm 500 lfpm	8 SOIC 8 SOIC	190 130	°C/W °C/W
θ <sub>JC</sub>	Thermal Resistance (Junction-to-Case)	Standard Board	8 SOIC	41 to 44	°C/W
θ <sub>JA</sub>	Thermal Resistance (Junction-to-Ambient)	0 lfpm 500 lfpm	8 TSSOP 8 TSSOP	185 140	°C/W °C/W
θ <sub>JC</sub>	Thermal Resistance (Junction-to-Case)	Standard Board	8 TSSOP	41 to 44 ± 5%	°C/W
T <sub>sol</sub>	Wave Solder	<2 to 3 sec @ 248°C		265	°C

Stresses exceeding Maximum Ratings may damage the device. Maximum Ratings are stress ratings only. Functional operation above the Recommended Operating Conditions is not implied. Extended exposure to stresses above the Recommended Operating Conditions may affect device reliability.

**Table 4. 10ELT SERIES PECL DC CHARACTERISTICS** V<sub>CC</sub> = 5.0 V; GND = 0.0 V (Note 2)

Symbol	Characteristic	-40°C			25°C			85°C			Unit
		Min	Typ	Max	Min	Typ	Max	Min	Typ	Max	
I <sub>CC</sub>	Power Supply Current			22			22			22	mA
V <sub>OH</sub>	Output HIGH Voltage (Note 3)	3920	4010	4110	4020	4105	4190	4090	4185	4280	mV
V <sub>OL</sub>	Output LOW Voltage (Note 3)	3050	3200	3350	3050	3210	3370	3050	3227	3405	mV

NOTE: Device will meet the specifications after thermal equilibrium has been established when mounted in a test socket or printed circuit board with maintained transverse airflow greater than 500 lfpm. Electrical parameters are guaranteed only over the declared operating temperature range. Functional operation of the device exceeding these conditions is not implied. Device specification limit values are applied individually under normal operating conditions and not valid simultaneously.

- Output parameters vary 1:1 with V<sub>CC</sub>. V<sub>CC</sub> can vary ± 0.25 V.
- Outputs are terminated through a 50 Ω resistor to V<sub>CC</sub> - 2.0 V.

**Table 5. 100ELT SERIES PECL DC CHARACTERISTICS** V<sub>CC</sub> = 5.0 V; GND = 0.0 V (Note 4)

Symbol	Characteristic	-40°C			25°C			85°C			Unit
		Min	Typ	Max	Min	Typ	Max	Min	Typ	Max	
I <sub>CC</sub>	Power Supply Current			22			22			22	mA
V <sub>OH</sub>	Output HIGH Voltage (Note 5)	3915	3995	4120	3975	4045	4120	3975	4050	4120	mV
V <sub>OL</sub>	Output LOW Voltage (Note 5)	3170	3305	3445	3190	3295	3380	3190	3295	3380	mV

NOTE: Device will meet the specifications after thermal equilibrium has been established when mounted in a test socket or printed circuit board with maintained transverse airflow greater than 500 lfpm. Electrical parameters are guaranteed only over the declared operating temperature range. Functional operation of the device exceeding these conditions is not implied. Device specification limit values are applied individually under normal operating conditions and not valid simultaneously.

- Output parameters vary 1:1 with V<sub>CC</sub>. V<sub>CC</sub> can vary ± 0.25 V.
- Outputs are terminated through a 50 Ω resistor to V<sub>CC</sub> - 2.0 V.

## MC10ELT22, MC100ELT22

**Table 6. TTL INPUT DC CHARACTERISTICS**  $V_{CC} = 4.75\text{ V to }5.25\text{ V}$ ;  $T_A = -40^\circ\text{C to }85^\circ\text{C}$

Symbol	Characteristic	Condition	Min	Typ	Max	Unit
$I_{IH}$	Input HIGH Current	$V_{IN} = 2.7\text{ V}$ ; $V_{IN} = (V_{CC} - 0.025)\text{ V}$			20	$\mu\text{A}$
$I_{IHH}$	Input HIGH Current	$V_{IN} = 7.0\text{ V}$			100	$\mu\text{A}$
$I_{IL}$	Input LOW Current	$V_{IN} = 0.5\text{ V}$ ; $V_{IN} = (\text{GND} + 0.025)\text{ V}$			-0.6	$\text{mA}$
$V_{IK}$	Input Clamp Diode Voltage	$I_{IN} = -18\text{ mA}$			-1.2	$\text{V}$
$V_{IH}$	Input HIGH Voltage		2.0		$V_{CC} - 0.025\text{ V}$	$\text{V}$
$V_{IL}$	Input LOW Voltage		$\text{GND} + 0.025\text{ V}$		0.8	$\text{V}$

NOTE: Device will meet the specifications after thermal equilibrium has been established when mounted in a test socket or printed circuit board with maintained transverse airflow greater than 500 lfm. Electrical parameters are guaranteed only over the declared operating temperature range. Functional operation of the device exceeding these conditions is not implied. Device specification limit values are applied individually under normal operating conditions and not valid simultaneously.

**Table 7. AC CHARACTERISTICS**  $V_{CC} = 4.75\text{ V to }5.25\text{ V}$ ;  $\text{GND} = 0.0\text{ V}$

Symbol	Characteristic	-40°C			25°C			85°C			Unit
		Min	Typ	Max	Min	Typ	Max	Min	Typ	Max	
$f_{MAX}$	Maximum Input Frequency					500					$\text{MHz}$
$t_{PLH}$	Propagation Delay (Note 6) 1.5 V to 50%	0.6		1.2	0.9	1.2	1.5	0.6		1.35	$\text{ns}$
$t_{PHL}$	Propagation Delay (Note 6) 1.5 V to 50%	0.4		1.0	0.5	0.8	1.1	0.7		1.30	$\text{ns}$
$t_{skew}$	Within-Device Skew (Note 7) Device-to-Device Skew (Note 8)		50 300	100 600		50 300	100 600		50 350	100 750	$\text{ps}$
$t_{JITTER}$	CLOCK Random Jitter (RMS)					0.5					$\text{ps}$
$t_r/t_f$	Output Rise/Fall Time (20–80%)	0.4		1.6	0.4		1.6	0.4		1.6	$\text{ns}$

NOTE: Device will meet the specifications after thermal equilibrium has been established when mounted in a test socket or printed circuit board with maintained transverse airflow greater than 500 lfm. Electrical parameters are guaranteed only over the declared operating temperature range. Functional operation of the device exceeding these conditions is not implied. Device specification limit values are applied individually under normal operating conditions and not valid simultaneously.

6. Specifications for standard TTL input signal.
7. Skew is measured between outputs under identical transitions and conditions on any one device.
8. Device-to-Device Skew for identical transitions at identical  $V_{CC}$  levels.

## MC10ELT22, MC100ELT22



**Figure 2. Typical Termination for Output Driver and Device Evaluation  
(See Application Note AND8020/D – Termination of ECL Logic Devices.)**

### ORDERING INFORMATION

Device	Package	Shipping <sup>†</sup>
MC10ELT22D	SO-8	98 Units / Rail
MC10ELT22DG	SO-8 (Pb-Free)	98 Units / Rail
MC10ELT22DR2	SO-8	2500 Tape & Reel
MC10ELT22DR2G	SO-8 (Pb-Free)	2500 Tape & Reel
MC10ELT22DT	TSSOP-8	100 Units / Rail
MC10ELT22DTG	TSSOP-8 (Pb-Free)	100 Units / Rail
MC10ELT22DTR2	TSSOP-8	2500 Tape & Reel
MC10ELT22DTR2G	TSSOP-8 (Pb-Free)	2500 Tape & Reel
MC100ELT22D	SO-8	98 Units / Rail
MC100ELT22DG	SO-8 (Pb-Free)	98 Units / Rail
MC100ELT22DR2	SO-8	2500 Tape & Reel
MC100ELT22DR2G	SO-8 (Pb-Free)	2500 Tape & Reel
MC100ELT22DT	TSSOP-8	100 Units / Rail
MC100ELT22DTG	TSSOP-8 (Pb-Free)	100 Units / Rail
MC100ELT22DTR2	TSSOP-8	2500 Tape & Reel
MC100ELT22DTR2G	TSSOP-8 (Pb-Free)	2500 Tape & Reel

<sup>†</sup>For information on tape and reel specifications, including part orientation and tape sizes, please refer to our Tape and Reel Packaging Specification Brochure, BRD8011/D.

## MC10ELT22, MC100ELT22

### Resource Reference of Application Notes

- AN1405/D** – ECL Clock Distribution Techniques
- AN1406/D** – Designing with PECL (ECL at +5.0 V)
- AN1503/D** – ECLinPS™ I/O SPiCE Modeling Kit
- AN1504/D** – Metastability and the ECLinPS Family
- AN1568/D** – Interfacing Between LVDS and ECL
- AN1672/D** – The ECL Translator Guide
- AND8001/D** – Odd Number Counters Design
- AND8002/D** – Marking and Date Codes
- AND8020/D** – Termination of ECL Logic Devices
- AND8066/D** – Interfacing with ECLinPS
- AND8090/D** – AC Characteristics of ECL Devices

# MC10ELT22, MC100ELT22

## PACKAGE DIMENSIONS

SOIC-8 NB  
CASE 751-07  
ISSUE AH

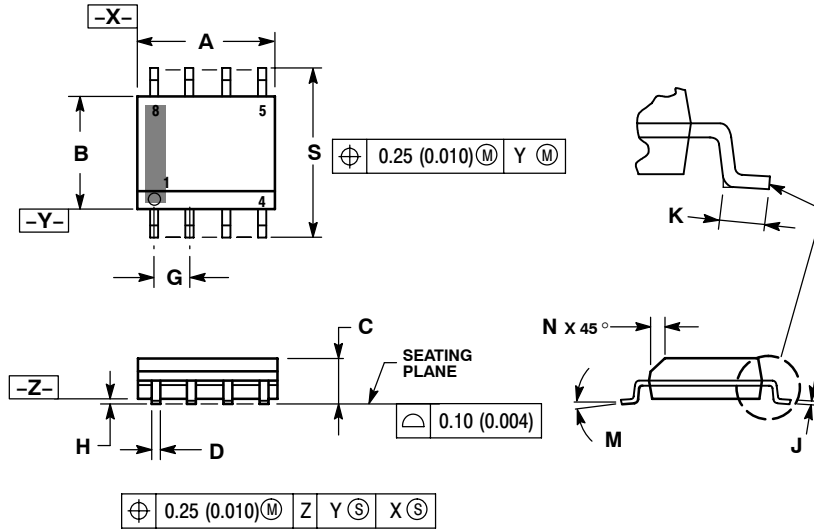

- NOTES:
1. DIMENSIONING AND TOLERANCING PER ANSI Y14.5M, 1982.
  2. CONTROLLING DIMENSION: MILLIMETER.
  3. DIMENSION A AND B DO NOT INCLUDE MOLD PROTRUSION.
  4. MAXIMUM MOLD PROTRUSION 0.15 (0.006) PER SIDE.
  5. DIMENSION D DOES NOT INCLUDE DAMBAR PROTRUSION. ALLOWABLE DAMBAR PROTRUSION SHALL BE 0.127 (0.005) TOTAL IN EXCESS OF THE D DIMENSION AT MAXIMUM MATERIAL CONDITION.
  6. 751-01 THRU 751-06 ARE OBSOLETE. NEW STANDARD IS 751-07.

DIM	MILLIMETERS		INCHES	
	MIN	MAX	MIN	MAX
A	4.80	5.00	0.189	0.197
B	3.80	4.00	0.150	0.157
C	1.35	1.75	0.053	0.069
D	0.33	0.51	0.013	0.020
G	1.27 BSC		0.050 BSC	
H	0.10	0.25	0.004	0.010
J	0.19	0.25	0.007	0.010
K	0.40	1.27	0.016	0.050
M	0°	8°	0°	8°
N	0.25	0.50	0.010	0.020
S	5.80	6.20	0.228	0.244

### SOLDERING FOOTPRINT\*

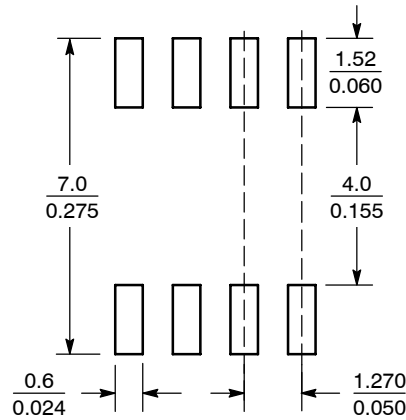

SCALE 6:1 ( $\frac{\text{mm}}{\text{inches}}$ )

\*For additional information on our Pb-Free strategy and soldering details, please download the ON Semiconductor Soldering and Mounting Techniques Reference Manual, SOLDERRM/D.

# MC10ELT22, MC100ELT22

## PACKAGE DIMENSIONS

TSSOP-8  
DT SUFFIX  
PLASTIC TSSOP PACKAGE  
CASE 948R-02  
ISSUE A

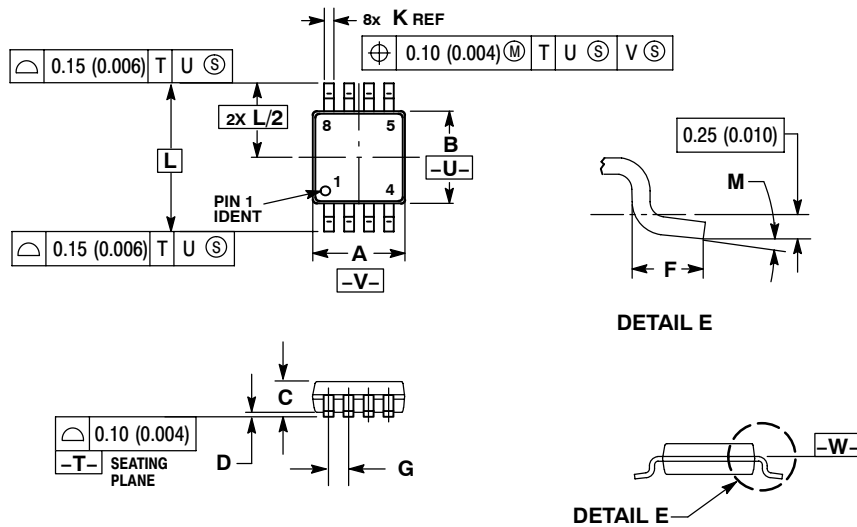

### NOTES:

1. DIMENSIONS AND TOLERANCING PER ASME Y14.5M, 1994.
2. CONTROLLING DIMENSION: MILLIMETER.
3. DIMENSION A DOES NOT INCLUDE MOLD FLASH. PROTRUSIONS OR GATE BURRS. MOLD FLASH OR GATE BURRS SHALL NOT EXCEED 0.15 (0.006) PER SIDE.
4. DIMENSION B DOES NOT INCLUDE INTERLEAD FLASH OR PROTRUSION. INTERLEAD FLASH OR PROTRUSION SHALL NOT EXCEED 0.25 (0.010) PER SIDE.
5. TERMINAL NUMBERS ARE SHOWN FOR REFERENCE ONLY.
6. DIMENSION A AND B ARE TO BE DETERMINED AT DATUM PLANE -W-.

DIM	MILLIMETERS		INCHES	
	MIN	MAX	MIN	MAX
A	2.90	3.10	0.114	0.122
B	2.90	3.10	0.114	0.122
C	0.80	1.10	0.031	0.043
D	0.05	0.15	0.002	0.006
F	0.40	0.70	0.016	0.028
G	0.65 BSC		0.026 BSC	
K	0.25	0.40	0.010	0.016
L	4.90 BSC		0.193 BSC	
M	0°	6°	0°	6°

ECLinPS is a trademark of Semiconductor Components Industries, LLC (SCILLC).

**ON Semiconductor** and **ON** are registered trademarks of Semiconductor Components Industries, LLC (SCILLC). SCILLC reserves the right to make changes without further notice to any products herein. SCILLC makes no warranty, representation or guarantee regarding the suitability of its products for any particular purpose, nor does SCILLC assume any liability arising out of the application or use of any product or circuit, and specifically disclaims any and all liability, including without limitation special, consequential or incidental damages. "Typical" parameters which may be provided in SCILLC data sheets and/or specifications can and do vary in different applications and actual performance may vary over time. All operating parameters, including "Typicals" must be validated for each customer application by customer's technical experts. SCILLC does not convey any license under its patent rights nor the rights of others. SCILLC products are not designed, intended, or authorized for use as components in systems intended for surgical implant into the body, or other applications intended to support or sustain life, or for any other application in which the failure of the SCILLC product could create a situation where personal injury or death may occur. Should Buyer purchase or use SCILLC products for any such unintended or unauthorized application, Buyer shall indemnify and hold SCILLC and its officers, employees, subsidiaries, affiliates, and distributors harmless against all claims, costs, damages, and expenses, and reasonable attorney fees arising out of, directly or indirectly, any claim of personal injury or death associated with such unintended or unauthorized use, even if such claim alleges that SCILLC was negligent regarding the design or manufacture of the part. SCILLC is an Equal Opportunity/Affirmative Action Employer. This literature is subject to all applicable copyright laws and is not for resale in any manner.

### PUBLICATION ORDERING INFORMATION

**LITERATURE FULFILLMENT:**  
Literature Distribution Center for ON Semiconductor  
P.O. Box 5163, Denver, Colorado 80217 USA  
**Phone:** 303-675-2175 or 800-344-3860 Toll Free USA/Canada  
**Fax:** 303-675-2176 or 800-344-3867 Toll Free USA/Canada  
**Email:** orderlit@onsemi.com

**N. American Technical Support:** 800-282-9855 Toll Free  
USA/Canada  
**Europe, Middle East and Africa Technical Support:**  
Phone: 421 33 790 2910  
**Japan Customer Focus Center**  
Phone: 81-3-5773-3850

**ON Semiconductor Website:** [www.onsemi.com](http://www.onsemi.com)  
**Order Literature:** <http://www.onsemi.com/orderlit>

For additional information, please contact your local Sales Representative



## X-ON Electronics

Largest Supplier of Electrical and Electronic Components

*Click to view similar products for [Translation - Voltage Levels](#) category:*

*Click to view products by [ON Semiconductor](#) manufacturer:*

Other Similar products are found below :

[NLJVHC1GT08DFT2G](#) [NLSX4373DMR2G](#) [NLSX5012MUTAG](#) [HV583GA-G](#) [MC10H641FNR2G](#) [NLSX0102FCT1G](#) [NLSX0102FCT2G](#)  
[NLSX4302EBMUTCG](#) [NLVSX4373DR2G](#) [PCA9306FMUTAG](#) [SY10H351JZ](#) [MC100EPT622MNG](#) [MAX9374AEKA+T](#) [MAX3378EETD+](#)  
[MAX34405BEZT+](#) [NLSX3014MUTAG](#) [NVT4556BUKZ](#) [NLSV4T244EMUTAG](#) [NLSX5011MUTCG](#) [NLV9306USG](#)  
[NLVSX4014MUTAG](#) [MAX34405BEZT+T](#) [NLSV4T3144MUTAG](#) [NSV12200LT1G](#) [NLVSX4373MUTAG](#) [NB3U23CMNTAG](#)  
[MAX3371ELT+T](#) [MAX3008EUP+T](#) [NLVPCA9306AMUTCG](#) [NLSX3013BFCT1G](#) [MAX9378EUA+T](#) [NLV7WBD3125USG](#)  
[NLV14504BDTG](#) [NLSX3012DMR2G](#) [NLSX5012DR2G](#) [MAX3391EEUD+T](#) [MAX3379EETD+](#) [PI4ULS3V4857GEAEX](#)  
[MAX3391EEBC+T](#) [MAX14842ATE+T](#) [74AVCH1T45FZ4-7](#) [CLVC16T245MDGGREP](#) [HEF4104BT](#) [TC74LCX16245\(EL,F\)](#)  
[MC10H124FNG](#) [CAVCB164245MDGGREP](#) [7WBD383USG](#) [NVT2001GM,115](#) [CLVC8T245MRHLTEP](#) [74LVC1G175GS,132](#)