

B and E Series Crystal



- HC-49/US Thru-Hole Crystal
- Wide Frequency Range
- RoHS Compliant Available
- Low Profile Package
- Resistance Weld



ELECTRICAL SPECIFICATIONS:

Frequency Range	3.200MHz to 91.730MHz
Frequency Tolerance / Stability	(See Part Number Guide for Options)
Operating Temperature Range	(See Part Number Guide for Options)
Storage Temperature	-55°C to +125°C
Aging	±5ppm / first year Max
Shunt Capacitance	7pF Max
Load Capacitance	20pF Standard (See Part Number Guide for Options)
Equivalent Series Resistance	See ESR Chart
Mode of Operation	Fundamental, or 3 rd OT
Drive Level	1mW Max
Shock	MIL-STD-883, Meth 2002, Cond B
Solderability	MIL-STD-883, Meth 2003
Solvent Resistance	MIL-STD-202, Meth 215
Vibration	MIL-STD-883, Meth 2007, Cond A
Gross Leak Test	MIL-STD-883, Meth 1014, Cond C
Fine Leak Test	MIL-STD-883, Meth 1014, Cond A

ESR CHART:

Frequency Range	ESR (Ohms)	Mode / Cut
3.200MHz to 4.999MHz	200 Max	Fund / AT
5.000MHz to 5.999MHz	150 Max	Fund / AT
6.000MHz to 7.999MHz	120 Max	Fund / AT
8.000MHz to 8.999MHz	90 Max	Fund / AT
9.000MHz to 9.999MHz	80 Max	Fund / AT
10.000MHz to 16.999MHz	50 Max	Fund / AT
17.000MHz to 24.999MHz	40 Max	Fund / AT
25.000MHz to 36.000MHz	25 Max	Fund / AT
24.000MHz to 34.999MHz	100 Max	3 rd OT / AT
35.000MHz to 59.999MHz	80 Max	3 rd OT / AT
60.000MHz to 91.730MHz	60 Max	3 rd OT / AT

MECHANICALS DETAIL:

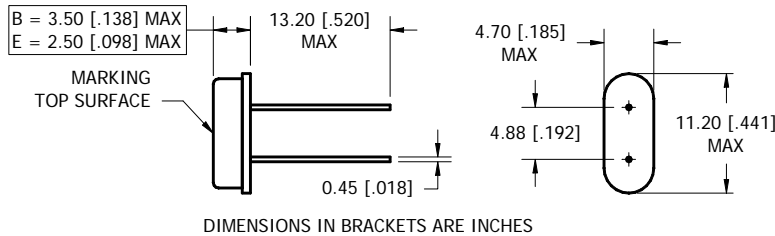

MARKING:

Line 1: MXX.XXX
XX.XXX = Frequency in MHz

Line 2: SYMCCCL
S = Internal Code
YM = Date Code (Year/Month)
CC = Crystal Parameters Code
L = Denotes RoHS Compliant

PART NUMBER GUIDE:

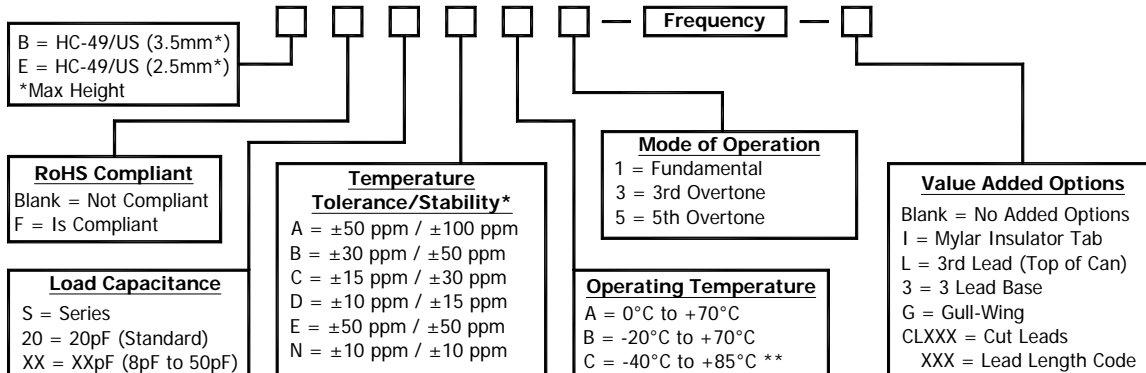

* Please consult with MMD sales department for any other parameters or options.
** Not all Frequency Tolerance/Stability options available at this temperature range.

MMD Components, 30400 Esperanza, Rancho Santa Margarita, CA, 92688

Phone: (949) 709-5075, Fax: (949) 709-3536, www.mmdcomp.com

Sales@mmdcomp.com

X-ON Electronics

Largest Supplier of Electrical and Electronic Components

Click to view similar products for [mmd monitor manufacturer](#):

Other Similar products are found below :

[BF20BA1-18.432MHZ](#) [BF20BA1-16.000MHZ](#) [BF20BA1-14.31818MHZ](#) [WC315-32.768KHZ](#)