

STB Self-Checking Optical Touch Buttons



Datasheet



- Continuous internal self-checking operation
- Diverse-redundant microcontroller-based photoelectric touch buttons
- Ergonomically designed to eliminate hand, wrist and arm stresses associated with repeated switch operation; require no physical pressure to operate
- High excess gain cuts through heavy contamination
- Immune to ambient light, EMI and RFI interference
- LED power, output and fault indicators
- Yellow field cover included

U.S. Patent(s) issued or pending

Model	Cable	Supply Voltage	Output Type	DUO-TOUCH® SG Compatibility
STBVP6	4-wire 2 m (6.5 ft) integral cable	10–30V dc	Complementary PNP	AT-FM-10K, AT-GM/HM-13A, and AT-GM/HM-11KM Two-Hand Control Modules, and SC22-3 Safety Controller
STBVP6Q	4-Pin Mini-style QD			
STBVP6Q5	4-Pin Euro-style QD			
STBVR81	5-wire 2 m (6.5 ft) integral cable	20–30V ac/dc	Two Individual Complementary Relays	
STBVR81Q	5-Pin Mini-style QD			
STBVR81Q6	5-Pin Euro-style QD			

Standard 2 m (6.5 ft) cable models are listed. To order the 9 m (30 ft) cable model, add suffix "W/30" to the cabled model number. For example, STBVP6 W/30. Models with a QD connector require a mating cable.



WARNING:

Not a Stand-Alone Safety Device. STB Series Touch Buttons are self-checking ergonomic actuating devices, but are not, by themselves, safety devices. To be used in a safety application, two STBs must be interfaced with a type IIIC two-hand-control module, such as the Banner AT-FM-10K, to meet all relevant safety requirements of the appropriate standards (e.g., ISO13851 / EN574).

Important - Read This Before Proceeding

The user is responsible for satisfying all local, state, and national laws, rules, codes, and regulations relating to the use of this product and its application. Banner Engineering Corp. has made every effort to provide complete application, installation, operation, and maintenance instructions. Please direct any questions regarding the use or installation of this product to the factory applications department at the telephone numbers or address found at <http://www.bannerengineering.com>.

The user is responsible for making sure that all machine operators, maintenance personnel, electricians, and supervisors are thoroughly familiar with and understand all instructions regarding the installation, maintenance, and use of this product, and with the machinery it controls. The user and any personnel involved with the installation and use of this product must be thoroughly familiar with all applicable standards, some of which are listed within the specifications. Banner Engineering Corp. makes no claim regarding a specific recommendation of any organization, the accuracy or effectiveness of any information provided, or the appropriateness of the provided information for a specific application.



Applicable U.S. Standards

ANSI B11 Standards for Machine Tools Safety

Contact: Safety Director, AMT – The Association for Manufacturing Technology, 7901 Westpark Drive, McLean, VA 22102, Tel.: 703-893-2900

ANSI NFPA 79 Electrical Standard for Industrial Machinery

Contact: National Fire Protection Association, 1 Batterymarch Park, P.O. Box 9101, Quincy, MA 02269-9101, Tel.: 800-344-3555

ANSI/RIA R15.06 Safety Requirements for Industrial Robots and Robot Systems

Contact: Robotic Industries Association, 900 Victors Way, P.O. Box 3724, Ann Arbor, MI 48106, Tel.: 734-994-6088

Applicable International Standards

ISO 12100-1 & -2 (EN 292-1 & -2) Safety of Machinery – Basic Concepts, General Principles for Design

IEC 60204-1 Electrical Equipment of Machines Part 1: General Requirements

ISO 13849-1 (EN 954-1) Safety-Related Parts of Control Systems

ISO 13856-1 (EN1760-1), Safety of Machinery – Pressure-Sensitive Protective Devices

Contact: Global Engineering Documents, 15 Inverness Way East, Englewood, CO 80112-5704, Tel.: 800-854- 7179

Overview

STB Self-Checking Optical Touch Buttons are touch-activated photoelectric devices designed to replace capacitive touch switches and mechanical push buttons. Their outputs activate while a finger is in the “touch area” (yoke) of the switch, interrupting the button’s infrared sensing beam.

Banner STB Series buttons are ergonomically designed to eliminate the hand, wrist, and arm stresses associated with mechanical push buttons. They require absolutely no physical pressure to operate. LED indicators light when power is on and outputs are activated.

All models are immune to EMI, RFI, and ambient light interference. STBs have a black polyetherimide upper housing and yellow PBT base. The 30 mm threaded base on all models provides easy mounting and easy retrofitting into existing applications. Rugged yellow polypropylene (TP) field covers are supplied with all models to prevent inadvertent switch actuation due to objects (such as loose clothing or debris) which might accidentally block the sensing beam. The polypropylene material is capable of absorbing high impact (even at low temperatures) and is highly resistant to abrasion and to damage by most chemicals.

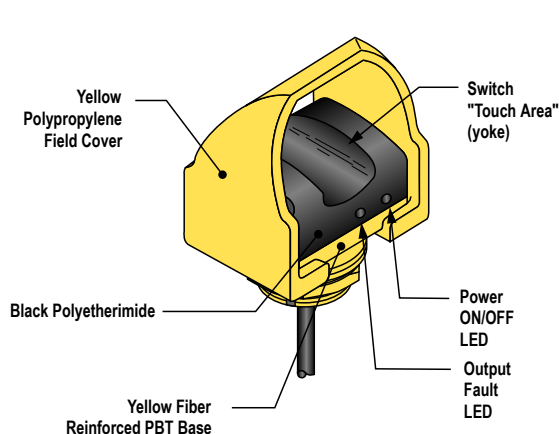

Figure 1. STB Touch Button features



WARNING: Point-of-Operation Guarding

When properly installed, a two-hand control device provides protection only for the hands of the machine operator. It may be necessary to install additional safeguarding, such as safety light screens, additional two-hand controls, and/or hard guards, to protect all individuals from hazardous machinery.

Failure to properly guard hazardous machinery can result in a dangerous condition which could lead to serious injury or death.

STB Self-Checking Optical Touch Buttons are very similar to the proven and popular OTB Series buttons. The dual-microcontroller internal design of the new buttons, however, allows the hookup to a Banner DUO-TOUCH SG Two-Hand-Control Safety Module, or other two-hand-control designed to meet Type IIIC requirements per ISO 13851 (EN 574) (requiring 1 normally open and 1 normally closed contact per input channel). These microcontrollers perform a continuous

self-check. The emitter is continuously pulsed, and receiver response is checked accordingly by the microcontrollers. STB Series Touch Buttons are designed to immediately detect any internal component failure, go into a lockout mode, and indicate the failure with a flashing green Fault LED.

The STB outputs are not monitored by the STB circuitry, and have no external device monitoring feedback. Output monitoring must be accomplished by using an external device, such as a Type IIIC Two-Hand-Control module.

STB Series Touch Button LED Indicators	
Power On (green):	Solid when power is applied
Output, Fault (green):	Solid when button is activated
	Off when button is not activated
	Flashing when a fault condition is detected

STB Series Self-Checking Touch Buttons were designed primarily to provide the self-checking function required in control-reliable machine cycle initiation applications. STBs also are suitable for use anywhere mechanical push buttons or the original OTB Touch Buttons are used.

Both the solid-state and relay-output versions have complementary outputs and can be connected to switch power to equipment as long as the STB's switching voltage and current limits are not exceeded.

STBs must be connected to a type IIIC Two-Hand-Control circuit module, in most cases, when used to initiate potentially dangerous machine cycles.

Installation

OSHA and ANSI require that the hand controls be mounted to protect them from accidental or unintentional operation. Use shields, covers, rings, collars, dividers, or similar protection to prevent accidental switch actuation and to discourage use of forearms or elbows. European standard ISO 13851 (EN 574) includes a detailed discussion of approaches to protection of hand controls. The hand controls must be arranged far enough apart so that the operator cannot operate both hand controls by the use of one arm. Typically, this distance is not less than 550 mm (21.7") in a straight line, but using guards or alternate mounting arrangement can allow shorter distances, per ISO 13851 (EN574). This standard also recommends that hand controls be arranged on a horizontal (or nearly horizontal) surface that is 1,100 mm (43.3") above the floor.

Consider ergonomic principles to avoid unnecessary fatigue in the installation of the hand controls. Install the touch buttons at a height and in a location that will be comfortable for the user. See ISO 13851 (EN574) Two-Hand Control, ANSI B11. TR1—Ergonomic Guidelines, and EN894— Safety of Machinery—Ergonomic Requirements—Control Actuators for further information.

The following figure shows two methods for mounting the touch buttons, to prevent accidental switch actuation. When mounting them on top of the control bar, the protective field covers should be in place, as shown; or for added protection, mount the touch buttons sideways under and/or behind a protective hood, rather than on top of the bar, removing the field covers. This side mount prevents an object from being left in the path of the beam, intentionally bypassing the safeguard. In addition, shields, covers, rings, collars, dividers, or similar protection may be used to prevent accidental switch actuation.

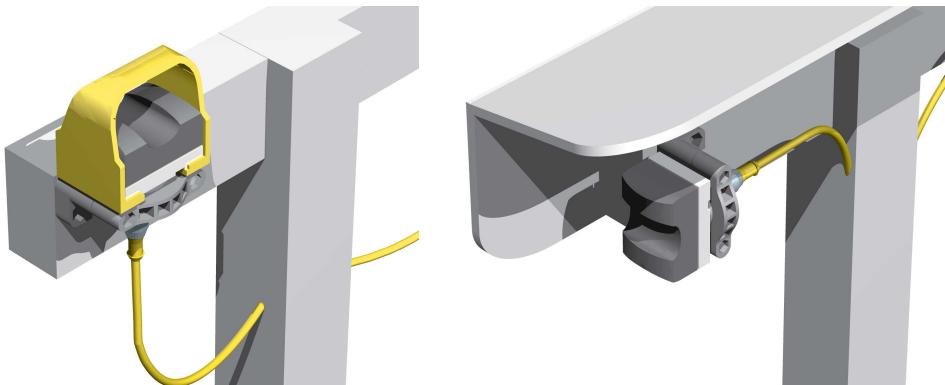

Figure 2. Protect STB touch buttons to prevent defeat or inadvertent actuation

**CAUTION: Install Hand Controls to Prevent Accidental Actuation**

Total protection for the two-hand control system from defeat is not possible. However, the user is required by U.S. and International standards to arrange and protect hand controls to minimize the possibility of defeat or accidental actuation.

**CAUTION: Hand Controls**

The environment in which hand controls are installed must not adversely affect the means of actuation. Severe contamination or other environmental influences may cause slow response or false On conditions of mechanical or ergonomic buttons. This may result in exposure to a hazard.

Two-Hand Control Safety Distance (Minimum Distance)

Both hand controls must be located far enough away from the nearest hazard point that the operator cannot reach the hazard with a hand or other body part before the hazardous motion ceases. This is the “separation distance” (“safety distance”), and may be calculated as follows.

**WARNING: Location of Touch Button Controls**

Hand controls must be mounted a safe distance from moving machine parts, as determined by the appropriate standard. It must not be possible for the operator or other non-qualified persons to relocate them. Failure to establish and maintain the required safety distance may result in serious injury or death.

U.S. Applications

The Safety Distance formula, as provided in ANSI B11.19:

Part-Revolution Clutch Machinery (the machine and its controls allow the machine to stop motion during the hazardous portion of the machine cycle)

$$D_s = K \times (T_s + T_r + T_h)$$

For Full-Revolution Clutch Machinery (the machine and its controls are designed to complete a full machine cycle)

$$D_s = K \times (T_m + T_r + T_h)$$

D_s

the Safety Distance (in inches)

K

the OSHA/ANSI recommended hand-speed constant (in inches per second), in most cases is calculated at 63 in/sec, but may vary between 63 to 100 in/sec based on the application circumstances
not a conclusive determination; consider all factors, including the physical ability of the operator, when determining the value of K to be used

T_h

the response time of the slowest hand control from the time when a hand disengages that control until the switch opens
 T_h is usually insignificant for purely mechanical switches. However, T_h should be considered for safety distance calculation when using electronic or electromechanical (powered) hand controls. For Banner Self-checking Touch Buttons (STBs) the response time is 0.02 seconds

T_m

the maximum time (in seconds) the machine takes to cease all motion after it has been tripped. For full revolution clutch presses with only one engaging point, T_m is equal to the time necessary for one and one-half revolutions of the crankshaft. For full revolution clutch presses with more than one engaging point, T_m is calculated as follows:

$$T_m = (1/2 + 1/N) \times T_{cy}$$

N = number of clutch engaging points per revolution

T_{cy} = time (in seconds) necessary to complete one revolution of the crankshaft

T_r

the response time of the Safety Controller as measured from the time a stop signal from either hand control. The Safety Controller response time is obtained from the Configuration Summary in the PC Interface.

T_s

the overall stop time of the machine (in seconds) from the initial stop signal to the final ceasing of all motion, including stop times of all relevant control elements and measured at maximum machine velocity
 T_s is usually measured by a stop-time measuring device. If the specified machine stop time is used, add at least 20% as a safety factor to account for brake system deterioration. If the stop-time of the two redundant machine control elements is unequal, the slower of the two times must be used for calculating the separation distance

European Applications

The Minimum Distance Formula, as provided in ISO 13855:

$$S = (K \times T) + C$$

- S the Minimum Distance (in millimeters)
- K the ISO 13855 recommended hand-speed constant (in millimeters per second), in most cases is calculated at 1600 mm/sec, but may vary between 1600 to 2500 mm/sec based on the application circumstances not a conclusive determination; consider all factors, including the physical ability of the operator, when determining the value of K to be used.
- T the overall machine stopping response time (in seconds), from the physical initiation of the safety device to the final ceasing of all motion
- C the added distance due to the depth penetration factor equals 250 mm, per ISO 13855. The ISO 13855 C factor may be reduced to 0 if the risk of encroachment is eliminated, but the safety distance must always be 100 mm or greater

Example Separation Distance Calculation

The following example illustrates the use of the formula to calculate separation distance for a part-revolution clutch machine. This example uses 0.50 seconds as a typical value for T_s and 0.035 seconds for T_r and 0.020 seconds for T_h :

$$\begin{aligned}
 K &= 63'' \text{ per second,} \\
 T_s &= 0.50 \text{ seconds (measured by a stop-time measuring device)} \\
 T_r &= 0.035 \text{ seconds} \\
 T_h &= 0.020 \text{ seconds} \\
 D_s &= K \times (T_s + T_r + T_h) \\
 &= 63'' (0.50 + 0.035 + 0.020) \\
 &= 35''
 \end{aligned}$$

In this example, both hand controls must be located no closer than 35" from the nearest hazard point.

Hookup Diagrams

Cabled models only are shown. Quick-disconnect wiring is functionally identical. Connection of dc power is without regard to polarity.

Electromechanical Relay Output Models

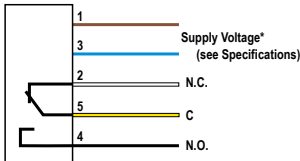

PNP (Sourcing) Solid-State Output Models

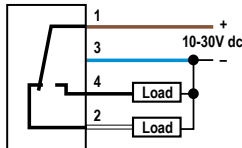

Wiring Key

- 1 = Brown
- 2 = White
- 3 = Blue
- 4 = Black
- 5 = Gray or Yellow

* NOTE: Connection of dc power is without regard to polarity.

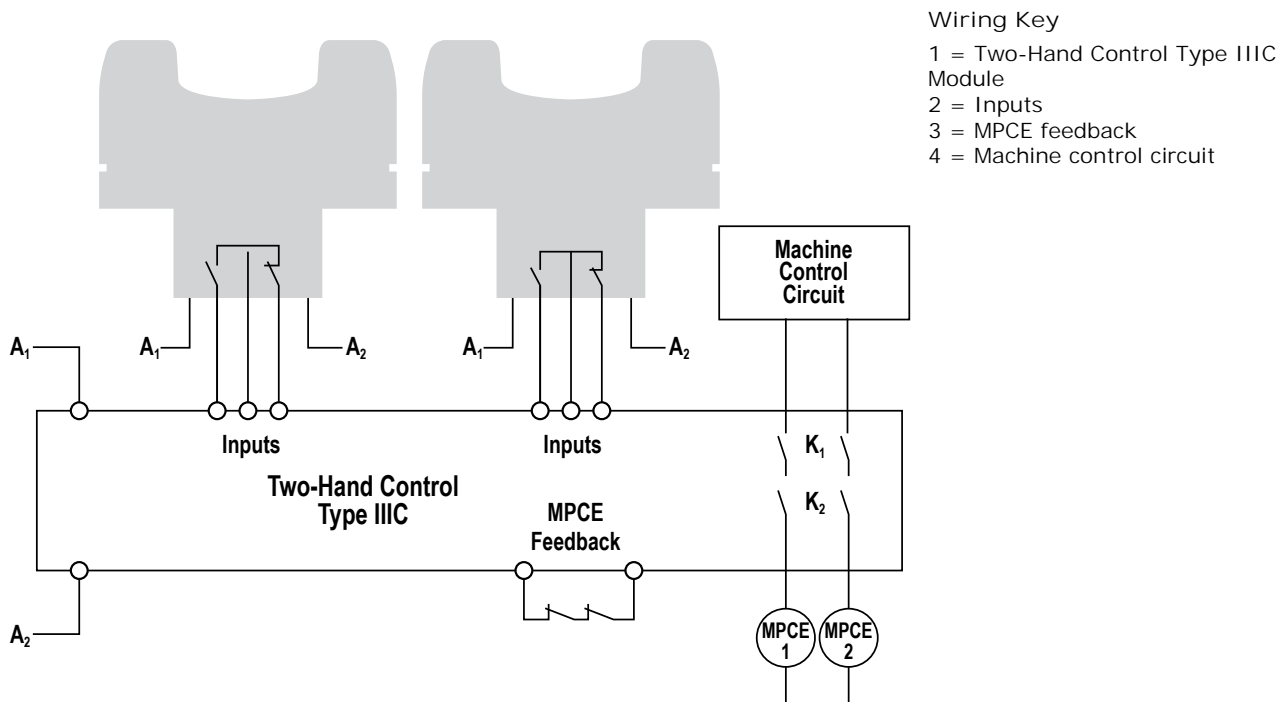

Figure 3. Generic interface of a relay-output STB Touch Button to a type IIIC two-hand-control module



WARNING:

Safety Systems Used for Two-Hand-Control. In a two-hand-control/trip system that incorporates STB Touch Buttons as the actuation devices and functions as a safeguard, the anti-tiedown and simultaneity monitoring functions should not be performed by a nonsafety-related device (e.g., a PLC or PC). Per OSHA 29CFR1910.211(d)(62), the "safety system must...operate together as a unit, such that a single failure or single operating error will not cause injury to personnel due to point-of-operation hazards."

Refer to the appropriate standard to determine the requirements of a two hand-control/trip system when used for safeguarding.

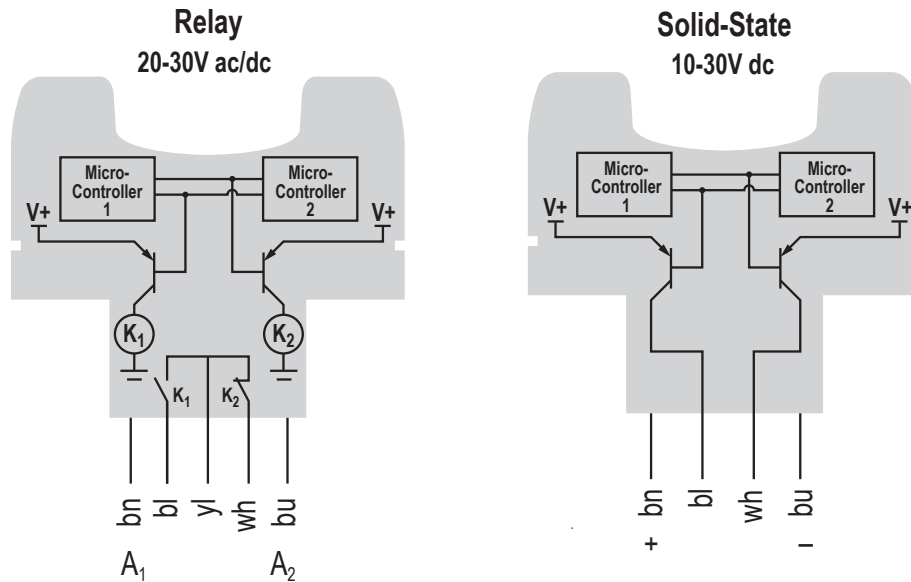

Figure 4. STB Touch Button block diagrams

Repairs

Contact Banner Engineering for troubleshooting of this device. Do not attempt any repairs to this Banner device; it contains no field-replaceable parts or components. If the device, device part, or device component is determined to be defective by a Banner Applications Engineer, they will advise you of Banner's RMA (Return Merchandise Authorization) procedure.



Important: If instructed to return the device, pack it with care. Damage that occurs in return shipping is not covered by warranty.

Specifications

Supply Voltage and Current

STBVP6 models: 10 to 30 V dc @ 75 mA, typical

STBVR81 models: 20 to 30 V ac/dc or 20 to 30 V ac (peak-to-peak value), (50/60 Hz \pm 5%) @ 75 mA

Supply Protection Circuitry

Protected against reverse polarity and transient voltages

Output Configuration

STBVP6 models: Complementary PNP (sourcing) open-collector transistors

STBVR81 models: Complementary electromechanical relays

Output Rating

STBVP6 models (solid-state outputs):

Max. load: 150 mA

On-state max. output voltage (no load): +V(supply) – 1.5 V

Off-state leakage current: < 1 μ A

STBVR81 models (electromechanical relays):

Max. switching voltage: 125 V dc/150 V ac

Max. switching current: 1 A @ 24 V dc; 0.4 A @ 125 V ac (resistive loads)

Max. resistive power: 24 W dc/50 VA ac

Mechanical life of relays: 10^9 cycles

Electrical life of relays: 1.5×10^5 cycles at 1 amp, 24 V resistive

Output Protection Circuitry

All models protected against false pulse on power-up. Models with solid-state outputs have overload and short-circuit protection.

Output Response Time

20 milliseconds ON/OFF

Indicators

2 green LED indicators:

Power: ON – power applied

Output/fault: ON – button is activated; OFF – button is deactivated; Flashing – internal fault or blocked button on power-up detected

Connections

PVC-jacketed 2 m (6.5') cables or QD fitting, depending on model: integral 9 m (30') cables are also available. Accessory QD cables required for QD models.

STBVP6 models: 4-wire (4-pin Mini-style or Euro-style QD)

STBVR81 models: 5-wire (5-pin Mini-style or Euro-style QD)

Environmental Rating

Meets NEMA standards 1, 3, 4, 4X, 12 and 13; IEC IP66

Construction

Totally encapsulated, non-metallic enclosure. Black polyetherimide upper housing; fiber-reinforced PBT polyester base. Electronics fully epoxy-encapsulated. Supplied with polypropylene (TP) field cover.

Ambient Light Immunity

Up to 100,000 lux

Applicable Agency Standards

(Used with an AT-FM-10K module or an SC22-3 Safety Controller) Analysis of measures for fault avoidance and fault control according to SIL3 (IEC 61508 and IEC 62061) and Category 4 (EN ISO 13849-1) passes EMI/RFI test levels as specified in IEC61496 and IEC62061..

Operating Conditions

0 to 50 °C (32 to 122 °F)

90% @ 55 °C max. relative humidity (non-condensing)

Application Notes

The polyetherimide upper housing will become brittle with prolonged exposure to outdoor sunlight. Window glass effectively filters longer wavelength ultraviolet light and provides excellent protection from sunlight. Avoid contact with strong alkalis, hydrocarbons and fuels. Clean periodically using mild soap solution and a soft cloth.

Two-Hand Control System Note

When the STBVP6 is used with Banner's SC22-3 Safety Controller in a two-hand control system, the power supply to the STBVP6 must be of the same voltage that is used to power the Safety Controller and they must have a common supply ground.

Certifications

Dimensions

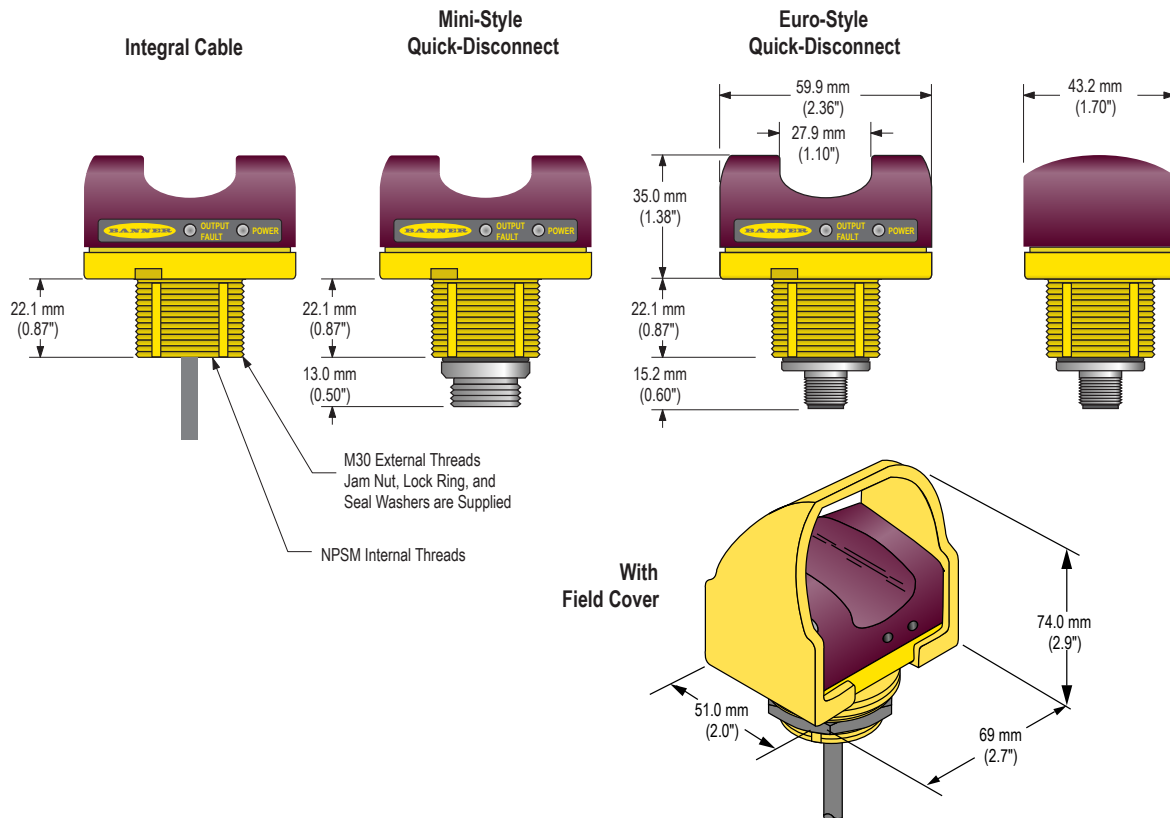

Accessories

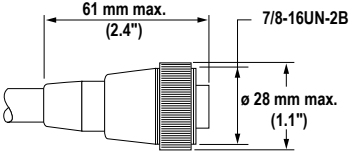
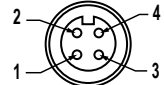
4-Pin Mini-Style Cordsets				
Model	Length	Style	Dimensions	Pinout
MBCC-406	1.83 m (6 ft)	Straight		 <p>1 = Brown 2 = White 3 = Blue 4 = Black</p>
MBCC-412	3.66 m (12 ft)			
MBCC-430	9.14 m (30 ft)			

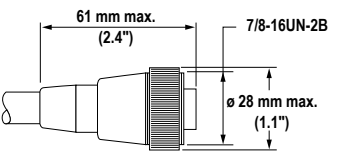
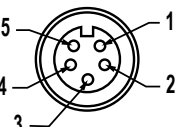
5-Pin Mini-Style Cordsets				
Model	Length	Style	Dimensions	Pinout
MBCC-506	1.83 m (6 ft)	Straight		 <p>1 = Black 2 = Blue 3 = Yellow 4 = Brown 5 = White</p>
MBCC-512	3.66 m (12 ft)			
MBCC-530	9.14 m (30 ft)			

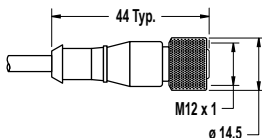
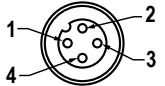
4-Pin Threaded M12/Euro-Style Cordsets				
Model	Length	Style	Dimensions	Pinout
MQDC-406	1.83 m (6 ft)	Straight		 <p>1 = Brown 2 = White 3 = Blue 4 = Black</p>
MQDC-415	4.57 m (15 ft)			
MQDC-430	9.14 m (30 ft)			
MQDC-450	15.2 m (50 ft)			

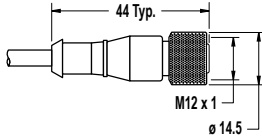
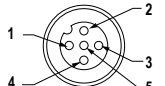
5-Pin Threaded M12/Euro-Style Cordsets (Single Ended)				
Model	Length	Style	Dimensions	Pinout (Female)
MQDC1-501.5	0.50 m (1.5 ft)	Straight		 <p>1 = Brown 2 = White 3 = Blue 4 = Black 5 = Gray</p>
MQDC1-506	1.83 m (6 ft)			
MQDC1-515	4.57 m (15 ft)			
MQDC1-530	9.14 m (30 ft)			

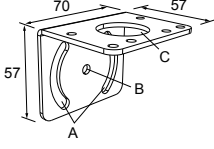
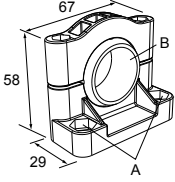
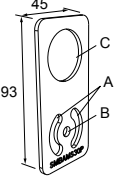
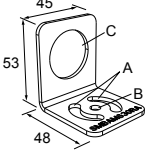
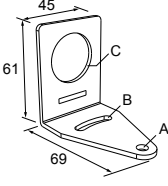
Mounting Brackets	
<p>SMB30MM</p> <ul style="list-style-type: none"> 12-ga. stainless steel bracket with curved mounting slots for versatile orientation Clearance for M6 (¼ in) hardware Mounting hole for 30 mm sensor  <p>Hole center spacing: A = 51, A to B = 25.4 Hole size: A = 42.6 x 7, B = ø 6.4, C = ø 30.1</p>	<p>SMB30SC</p> <ul style="list-style-type: none"> Swivel bracket with 30 mm mounting hole for sensor Black reinforced thermoplastic polyester Stainless steel mounting and swivel locking hardware included  <p>Hole center spacing: A=ø 50.8 Hole size: A=ø 7.0, B=ø 30.0</p>
<p>SMBAMS30P</p> <ul style="list-style-type: none"> Flat SMBAMS series bracket 30 mm hole for mounting sensors Articulation slots for 90° + rotation 12-ga. 300 series stainless steel  <p>Hole center spacing: A=26.0, A to B=13.0 Hole size: A=26.8 x 7.0, B=ø 6.5, C=ø 31.0</p>	<p>SMBAMS30RA</p> <ul style="list-style-type: none"> Right-angle SMBAMS series bracket 30 mm hole for mounting sensors Articulation slots for 90° + rotation 12-ga. (2.6 mm) cold-rolled steel  <p>Hole center spacing: A=26.0, A to B=13.0 Hole size: A=26.8 x 7.0, B=ø 6.5, C=ø 31.0</p>
<p>SMB30A</p> <ul style="list-style-type: none"> Right-angle bracket with curved slot for versatile orientation Clearance for M6 (¼ in) hardware Mounting hole for 30 mm sensor 12-ga. stainless steel  <p>Hole center spacing: A to B=40 Hole size: A=ø 6.3, B= 27.1 x 6.3, C=ø 30.5</p>	

Banner Engineering Corp Limited Warranty

Banner Engineering Corp. warrants its products to be free from defects in material and workmanship for one year following the date of shipment. Banner Engineering Corp. will repair or replace, free of charge, any product of its manufacture which, at the time it is returned to the factory, is found to have been defective during the warranty period. This warranty does not cover damage or liability for misuse, abuse, or the improper application or installation of the Banner product.

THIS LIMITED WARRANTY IS EXCLUSIVE AND IN LIEU OF ALL OTHER WARRANTIES WHETHER EXPRESS OR IMPLIED (INCLUDING, WITHOUT LIMITATION, ANY WARRANTY OF MERCHANTABILITY OR FITNESS FOR A PARTICULAR PURPOSE), AND WHETHER ARISING UNDER COURSE OF PERFORMANCE, COURSE OF DEALING OR TRADE USAGE.

This Warranty is exclusive and limited to repair or, at the discretion of Banner Engineering Corp., replacement. IN NO EVENT SHALL BANNER ENGINEERING CORP. BE LIABLE TO BUYER OR ANY OTHER PERSON OR ENTITY FOR ANY EXTRA COSTS, EXPENSES, LOSSES, LOSS OF PROFITS, OR ANY INCIDENTAL, CONSEQUENTIAL OR SPECIAL DAMAGES RESULTING FROM ANY PRODUCT DEFECT OR FROM THE USE OR INABILITY TO USE THE PRODUCT, WHETHER ARISING IN CONTRACT OR WARRANTY, STATUTE, TORT, STRICT LIABILITY, NEGLIGENCE, OR OTHERWISE.

Banner Engineering Corp. reserves the right to change, modify or improve the design of the product without assuming any obligations or liabilities relating to any product previously manufactured by Banner Engineering Corp.

X-ON Electronics

Largest Supplier of Electrical and Electronic Components

Click to view similar products for [banner manufacturer](#):

Other Similar products are found below :

[Q45VR2FPQ](#) [BTA23S](#) [RS-11](#) [L16F](#) [2LM3](#) [2PBA](#) [LM8-1](#) [LMT](#) [SM312CV](#) [SM31RQD](#) [LS4ELQ](#) [FX1](#) [Q45BB6LLQ](#) [QM42VP6AFV150Q](#)
[D12SP6FP](#) [MBCC-412](#) [BA23S](#) [BT21S](#) [BTA13S](#) [LM4-2](#) [Q25SP6LPQ](#) [ES-FA-6G](#) [T183E](#) [SLSP30-600Q88](#) [SLSP30-1200Q88](#) [OPBA5](#)
[PBAT](#) [SBLV1](#) [SMA91EQD](#) [SMA91E](#) [SMA912LVQD](#) [SMA912DQD](#) [SM2A312CVQD](#) [SM2A912LVQD](#) [SM31RL](#) [TL70RAQ](#) [TL70RQ](#)
[K50LGRYPQ](#) [LEDRR70X70-78587](#) [BRT-THG-4X4-5](#) [T18-2VNDL-Q8](#) [SLLP14-1190P88](#) [SME312DQD](#) [SM312CUQD](#) [BR-2](#) [BR23P](#)
[SM2A312FPQD](#) [SM2A312LVQD](#) [SM31EQD](#) [D12EP6FP](#)