



E5 Cam Latches

Overview

Modularity and simplicity in action

The *SOUTHCO*® E5 cam latch is a highly modular and easy to configure solution, suitable for a wide range of applications. By changing any of the three basic components (access style driver, latch body or cam) in either geometry or material, the E5 can be easily adjusted to suit most applications.

Product features

- Cost effective, easy to design and install
- Multiple material and access options to suit multiple needs
- Sealed to meet NEMA 4 / IP65 standards
- Corrosion-resistant materials available
- Highly modular and configurable

➤ Match material and finish options for style and functionality requirements

A variety of materials and finishes to complement your application.

Die-cast zinc latch bodies standard finishes:



Chrome plated



Black powder coated

Corrosion resistant materials available



316
Stainless steel



Glass-filled
nylon, black



304
Stainless steel

➤ Select one of these four styles to fit your access requirements

There are four basic E5 styles to meet specific door configuration and mounting requirements in terms of design, depth, surface protrusion and operation style.

E5 Removable handle version

- Dual handle / key function
- Flush installation
- Premium finish and corrosion resistance

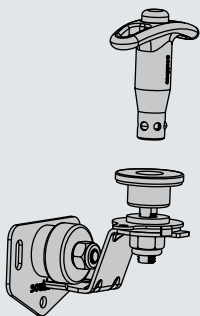

See www.southco.com/e5a for details

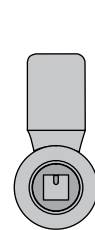

E5 Standard

Industry standard, highly modular and configurable options in a wide choice of materials, finishes and access styles. (See pages 86 - 89, 92 - 95)

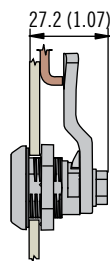

E5 Low Profile

Stylish, low profile design. Tool and hand operated access styles in zinc alloy chrome plated or black powder coated. (See page 88)

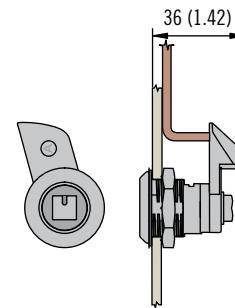

E5 Push-to-Close

Standard E5 with the added functionality of a spring-loaded cam or actuator for single or multi-point operation. Provides quicker turn-to-open, push-to-close action. (See pages 96 - 97)

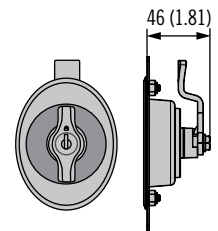

E5 Flush Cup Wing Knob

Stylish oval cup design. Provides a clean, flush outer surface. Ideal for multi-point actuation of large doors in aesthetically pleasing applications. (See pages 90 -91)

Dimensions in millimeters (inch) unless otherwise stated



www.southco.com

southco
CONNECT · CREATE · INNOVATE

➤ Choose from a wide range of operating styles to fit application and industry requirements.

- Convenient hand-operated wing knob, T and L-handle styles for easy hand access
- Tool operated for restricted access, flush-mount or low-profile clearances, and industry-specific standards
- Key operated for added security

Hand operable

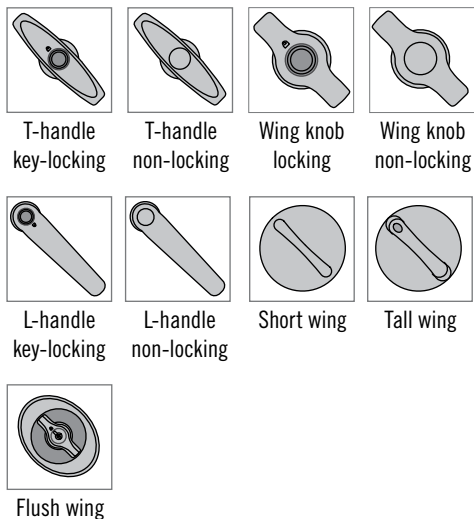

Tool / key operable

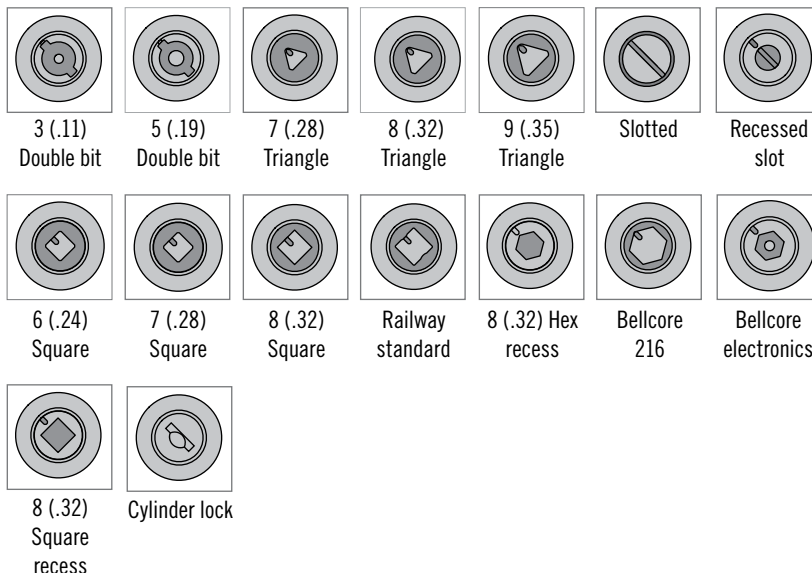

➤ Determine your grip options for a perfect fit

(Total grip includes the dimensions of all elements in-between the mounting surface of the latch and the latch's contact surface on the frame - including door thickness, compressed seals and gaskets, accessories, frame offset, etc.)

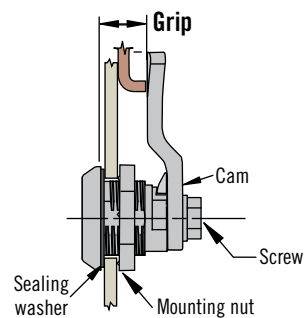

Selecting the right cam for the E5 is easy once the total grip is known. Southco provides a wide selection of standard cams in many grip increments, and special ones like hook and push-to-close cams. Standard cams provide vibration resistance and grip variation tolerance.

Installation

Some *SOUTHCO*® E5 latches are shipped latch and cam separately and some completely pre-assembled. See product pages for details.

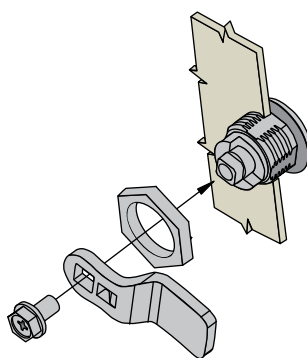

E5 Standard
Latch and cam shipped separately.

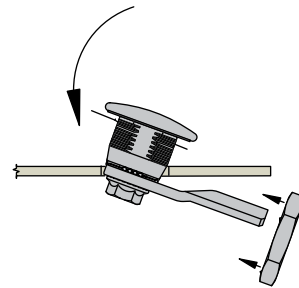

E5 Low Profile
Latch and cam shipped pre-assembled.



E5 Cam Latch

Stainless steel · Tool operated · Fixed grip

- Single hole install
- Latched / unlatched indicator

Material and Finish

Stainless steel, 304 or 316 grade

Performance Details

Max. static load:

304 Stainless steel 550 N (124 lbf)

316 Stainless steel 670 N (150 lbf)

Sealing Notes

NEMA 4 / IP65 achieved using gasket supplied

Installation Notes

Mounting nut:

Max. tightening torque:

20 N·m (177 in·lbf)

Screw Max. tightening torque

10 N·m (90 in·lbf)

Keys and Accessories

See page 98 - 101

Part Number Selection

Order latch and cam separately

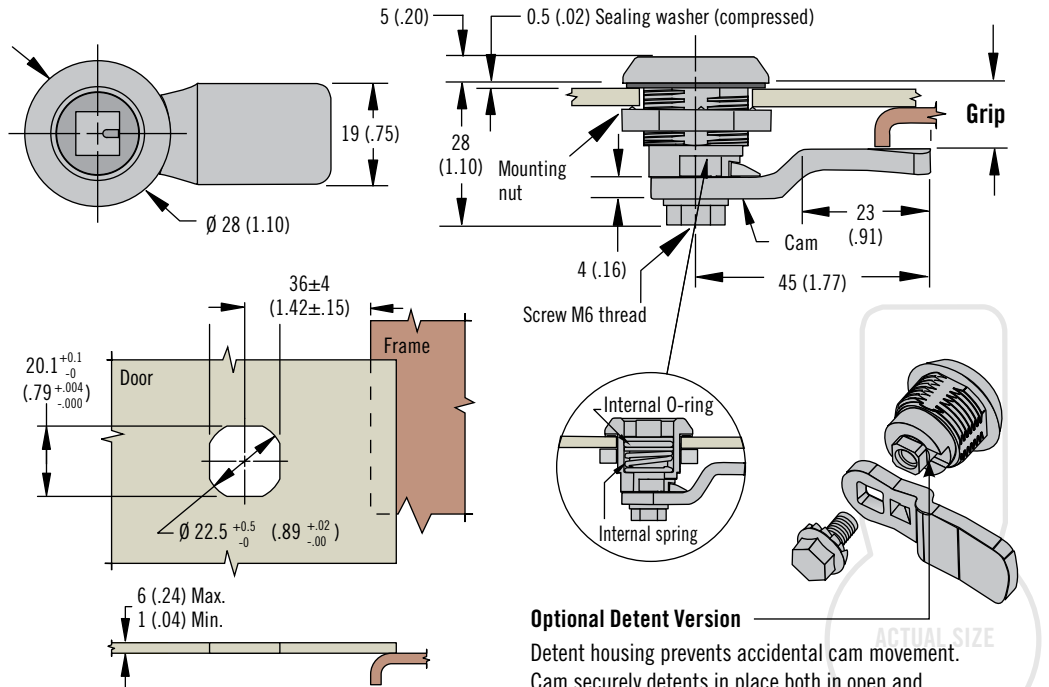

H Head Styles

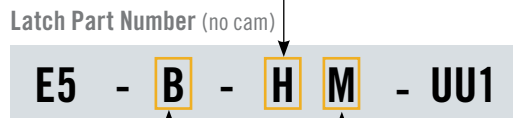
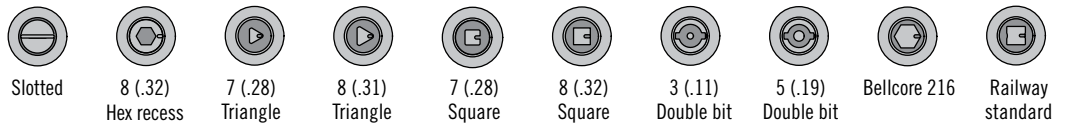

- B Body**
- 6 Normal housing
 - 32 Detented housing

- H Head style**
- 00 Slotted
 - 01 8 (.32) Hex recess
 - 02 7 (.28) Triangle
 - 03 8 (.32) Triangle
 - 04 7 (.28) Square

- M Material**
- 24 304 Stainless steel
 - 27 316 Stainless steel

- 05 8 (.32) Square
- 06 3 (.11) Double bit
- 07 5 (.19) Double bit
- 13 Bellcore 216
- 22 Railway standard

Cam Part Number Table (order separately from latch)

Grip +2(.08) - 0 (.00)	Part Number		Grip +2(.08) - 0 (.00)	Part Number		Grip +2(.08) - 0 (.00)	Part Number		Grip +2(.08) - 0 (.00)	Part Number	
	304 Stainless steel	316 Stainless steel		304 Stainless steel	316 Stainless steel		304 Stainless steel	316 Stainless steel		304 Stainless steel	316 Stainless steel
4 (.16)	E5-8003	E5-9003	14 (.55)	E5-8008	E5-9008	24 (.94)	E5-8013	E5-9013	34 (1.34)	E5-8018	E5-9018
6 (.24)	E5-8004	E5-9004	16 (.63)	E5-8009	E5-9009	26 (1.02)	E5-8014	E5-9014	36 (1.42)	E5-8019	E5-9019
8 (.31)	E5-8005	E5-9005	18 (.71)	E5-8010	E5-9010	28 (1.10)	E5-8015	E5-9015	38 (1.50)	E5-8020	E5-9020
10 (.39)	E5-8006	E5-9006	20 (.79)	E5-8011	E5-9011	30 (1.18)	E5-8016	E5-9016	40 (1.57)	E5-8021	E5-9021
12 (.47)	E5-8007	E5-9007	22 (.87)	E5-8012	E5-9012	32 (1.25)	E5-8017	E5-9017	42 (1.65)	E5-8022	E5-9022



E5 Cam Latch

Zinc · Tool operated · Fixed grip

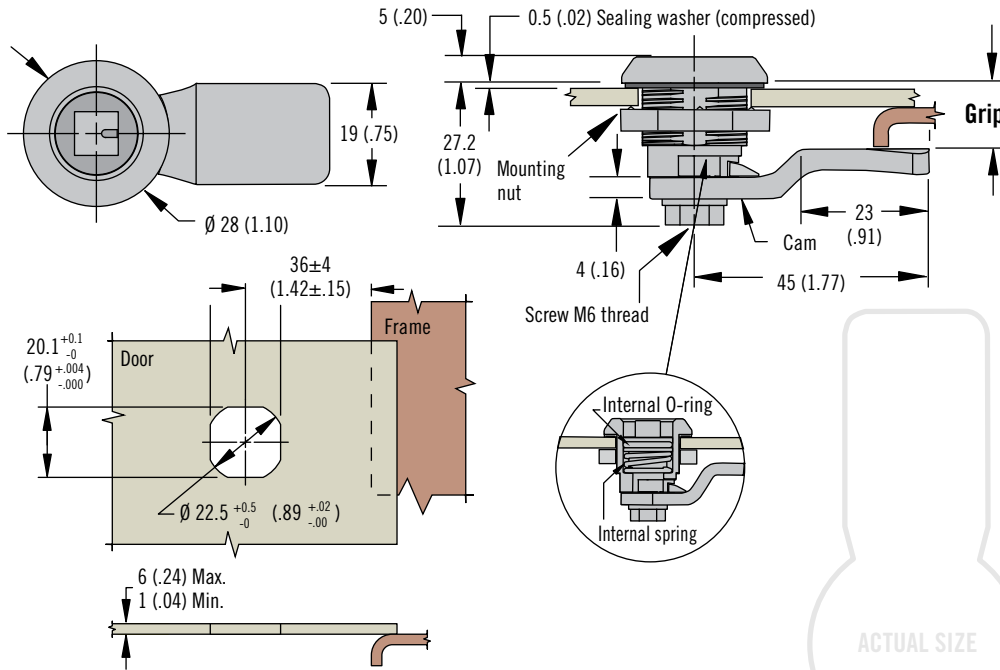

- Single hole install
- Latched / unlatched indicator

Material and Finish

Zinc alloy, powder coated or chrome plated and steel, zinc plated

Performance Details

Max. static load: 330 N (74 lbf)

Installation Notes

Mounting nut:

Max. tightening torque:
10 N·m (88 in·lbf)

Screw Max. tightening torque:
5 N·m (45 in·lbf)

Sealing Notes

NEMA 4 / IP65 achieved using gasket supplied

Keys and Accessories

See pages 98 - 101

Notes

Suitable for push-to-close action
see pages 96 - 97

H Head Styles

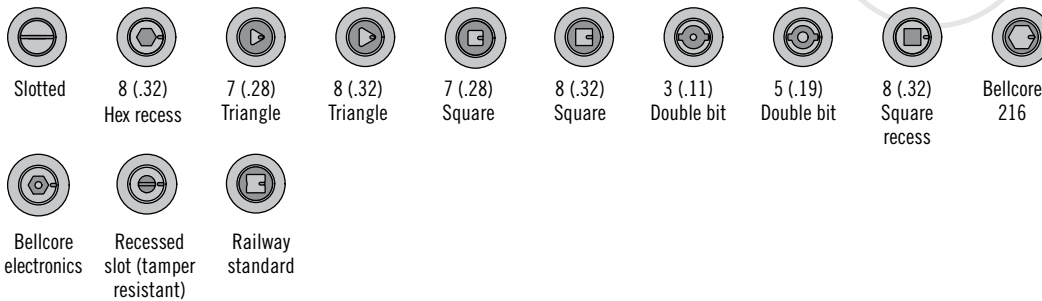

Latch Part Number (no cam)

E5 - 6 - H F - UU1

F Finish

- 2 Bright chrome
- 5 Black powder coated

H Head style

- 00 Slotted
- 01 8 (.32) Hex recess
- 02 7 (.28) Triangle
- 03 8 (.32) Triangle
- 04 7 (.28) Square
- 05 8 (.32) Square

- 06 3 (.11) Double bit
- 07 5 (.19) Double bit
- 08 8 (.32) Square recess
- 13 Bellcore 216
- 19 Bellcore electronics
- 21 Recessed slot (tamper resistant)
- 22 Railway standard

Part Number Selection

Order latch and cam separately

Cam Part Number Table (order separately from latch)							
Grip +2(.08) -0(.00)	Part Number	Grip +2(.08) -0(.00)	Part Number	Grip +2(.08) -0(.00)	Part Number	Grip +2(.08) -0(.00)	Part Number
4 (.16)	E5-6003	14 (.55)	E5-6008	24 (.94)	E5-6013	34 (1.34)	E5-6018
6 (.24)	E5-6004	16 (.63)	E5-6009	26 (1.02)	E5-6014	36 (1.42)	E5-6019
8 (.31)	E5-6005	18 (.71)	E5-6010	28 (1.10)	E5-6015	38 (1.50)	E5-6020
10 (.39)	E5-6006	20 (.79)	E5-6011	30 (1.18)	E5-6016	40 (1.57)	E5-6021
12 (.47)	E5-6007	22 (.87)	E5-6012	32 (1.25)	E5-6017	42 (1.65)	E5-6022



E5 Cam Latch Low Profile

Zinc · Tool or hand operated · Fixed grip

- Single hole install
- Latched / unlatched indicator
- Shipped fully assembled

Material and Finish

Zinc alloy, powder coated or chrome plated and steel, zinc plated

Performance Details

Max. static load: 330 N (74 lbf)

Installation Notes

Mounting nut

Max. tightening torque:
10 N·m (88 in·lbf)

Keys and Accessories

See pages 98 - 101

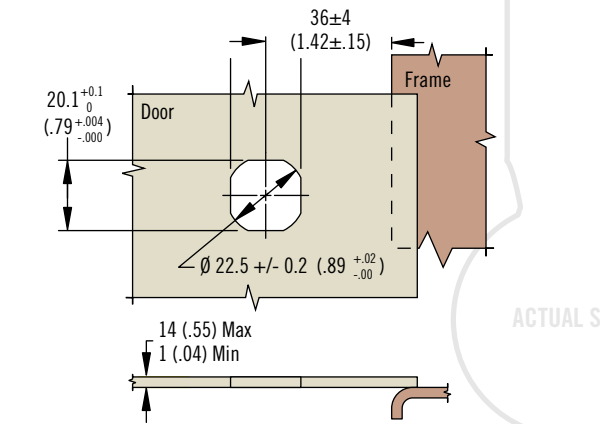
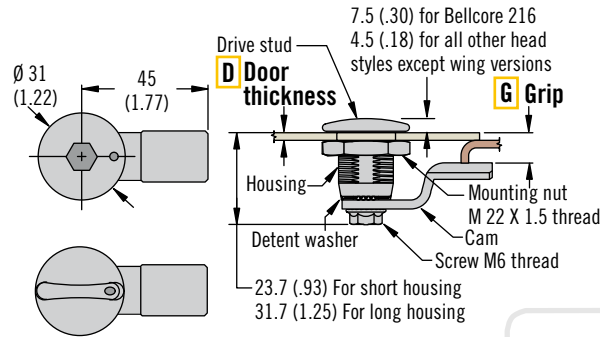

H Head Styles

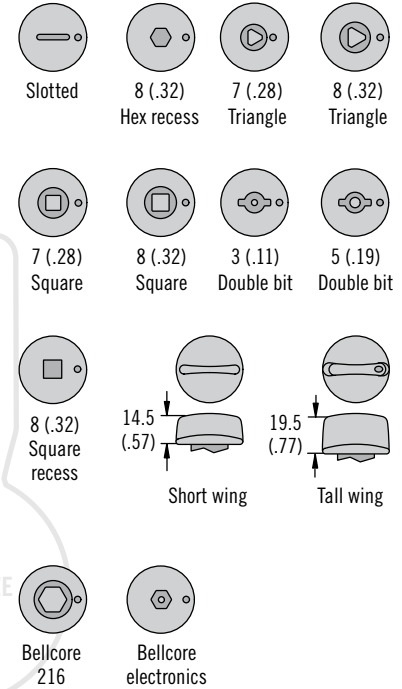

Part Number Selection

Latch is shipped fully assembled

For door thicknesses

1 - 6 (.039 - .236) grip must exceed door thickness range by 4 (.157) for assembled installation

When sealing option is selected add 0.4 (.02) to grip calculation to accommodate sealing washer

H Head style

- 00 Slotted
- 01 8 (.32) Hex recess
- 02 7 (.28) Triangle
- 03 8 (.32) Triangle
- 04 7 (.28) Square
- 05 8 (.32) Square
- 06 3 (.11) Double bit
- 07 5 (.19) Double bit
- 08 8 (.32) Square recess
- 11 Short wing
- 12 Tall wing
- 13 Bellcore 216
- 19 Bellcore Electronics

F Finish

- 1 Textured chrome
- 5 Black powder coated

S Sealing option

- 0 No o-ring or external seal
- 1 O-ring and external seal to meet NEMA 4/IP65 standards

E5 - D - H F - G S

D Door thickness range

- 1 1 - 6 (.039 - .236) (short housing supplied)
- 2 1 - 14 (.039 - .551) (long housing supplied)

G Grip table

G	Grip		G	Grip		G	Grip		G	Grip	
	Short housing	Long housing		Short housing	Long housing		Short housing	Long housing		Short housing	Long housing
00	Do not use	6 (.24)	05	8 (.31)	16 (.63)	10	18 (.71)	26 (1.02)	15	28 (1.10)	36 (1.42)
01	Do not use	8 (.31)	06	10 (.39)	18 (.71)	11	20 (.79)	28 (1.10)	16	30 (1.18)	38 (1.50)
02	2 (.08)	10 (.39)	07	12 (.47)	20 (.79)	12	22 (.87)	30 (1.18)	17	32 (1.25)	40 (1.57)
03	4 (.16)	12 (.47)	08	14 (.55)	22 (.87)	13	24 (.94)	32 (1.25)	18	34 (1.34)	42 (1.65)
04	6 (.24)	14 (.55)	09	16 (.63)	24 (.94)	14	26 (1.02)	34 (1.34)	19	36 (1.42)	44 (1.73)

If grip falls between two choices, use the smaller option

Dimensions in millimeters (inch) unless otherwise stated



www.southco.com/E5

E5 Cam Latch

Glass-filled nylon · Tool operated · Fixed grip

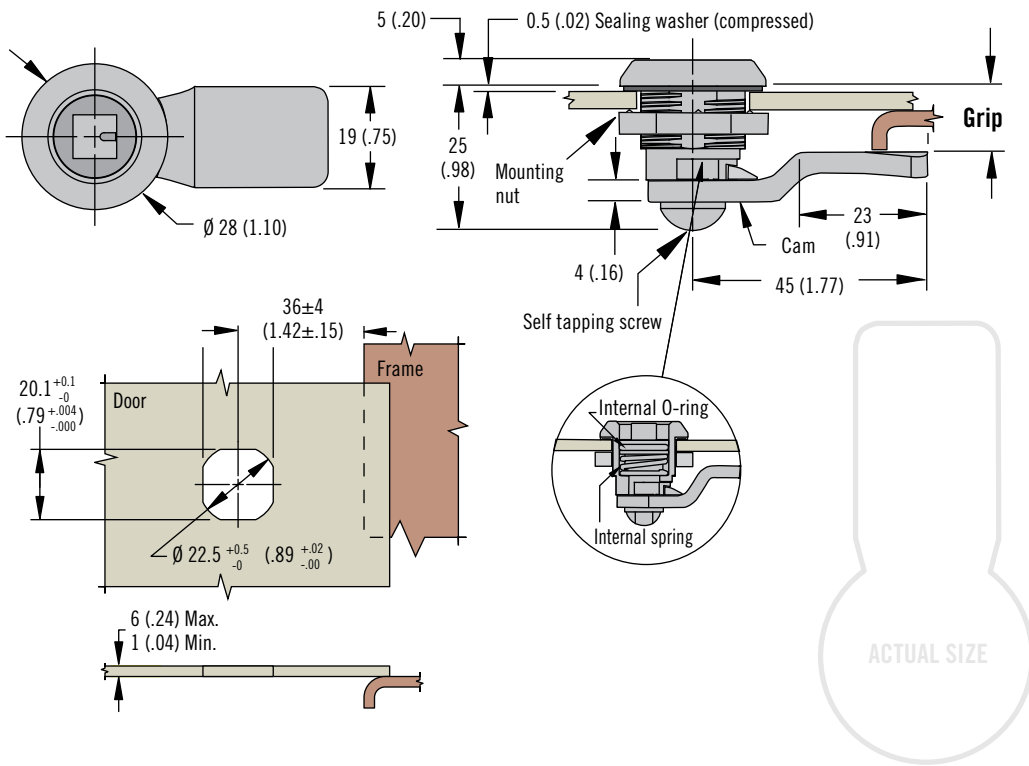

- Single hole install
- Latched / unlatched indicator

Material and Finish

Glass-filled nylon and steel, zinc plated

Performance Details

Max. static load: 300 N (67 lbf)

Installation Notes

Mounting nut:

Max. tightening torque:
4.25 N·m (38 in·lbf)

Screw Max. tightening torque:
3.1 N·m (27 in·lbf)

Keys and Accessories

See pages 98 - 101

H Head Styles

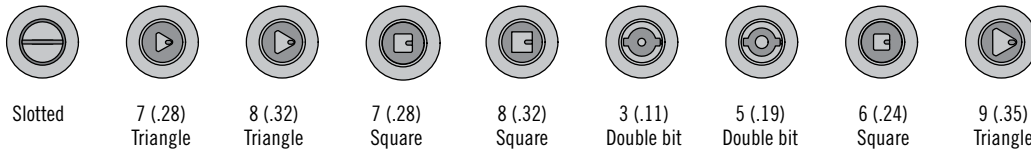

Part Number Selection

Order latch and cam separately

Latch Part Number
(no cam)

E5 - 6 - H 3 - UU1

H Head style

- 00 Slotted
- 02 7 (.28) Triangle
- 03 8 (.32) Triangle
- 04 7 (.28) Square
- 05 8 (.32) Square
- 06 3 (.11) Double bit
- 07 5 (.19) Double bit
- 14 6 (.24) Square
- 15 9 (.35) Triangle

Cam Part Number Table (order separately from latch)

Grip +2(.08) -0(.00)	Part Number	Grip +2(.08) -0(.00)	Part Number	Grip +2(.08) -0(.00)	Part Number	Grip +2(.08) -0(.00)	Part Number
4 (.16)	E5-6003	14 (.55)	E5-6008	24 (.94)	E5-6013	34 (1.34)	E5-6018
6 (.24)	E5-6004	16 (.63)	E5-6009	26 (1.02)	E5-6014	36 (1.42)	E5-6019
8 (.31)	E5-6005	18 (.71)	E5-6010	28 (1.10)	E5-6015	38 (1.50)	E5-6020
10 (.39)	E5-6006	20 (.79)	E5-6011	30 (1.18)	E5-6016	40 (1.57)	E5-6021
12 (.47)	E5-6007	22 (.87)	E5-6012	32 (1.25)	E5-6017	42 (1.65)	E5-6022

Dimensions in millimeters (inch) unless otherwise stated



www.southco.com/E5



E5 Cam Latch

Zinc · Flush cup wing style · Hand operated · Fixed grip

- Low profile
- Multiple key code options

Material and Finish

Zinc alloy, powder coated and steel, zinc plated

Performance Details

Max. static load: 330 N (74 lbf)

Installation Notes

Mounting nuts 10-24 UNC (supplied) max. tightening torque: 3 N·m (25 in·lbf)

Screw max. tightening torque: 10 N·m (90 in·lbf)

Keys

See page 98

Notes

Two point push-to-close action: Internal spring causes return of wing knob and actuator to original latched position when wing knob is released after opening. Ideal for use with cables and rotary latches.

For lock core selection and a complete overview of the *SOUTHCO*® Key-Choice System see pages 182 - 183

Single Point

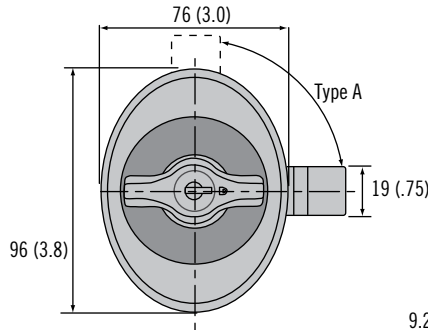

Two Point (for use with rods)

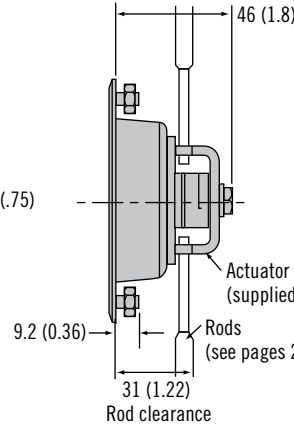

Two Point Push-to-Close Action (spring-loaded)

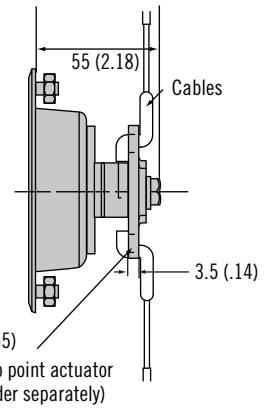

Max. door thickness

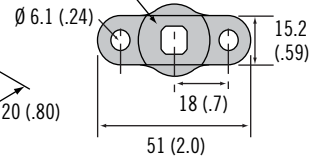
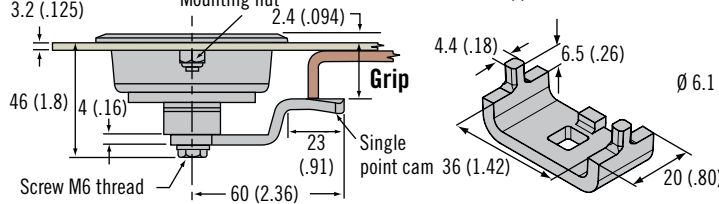

Type A (reverse frame for type B)

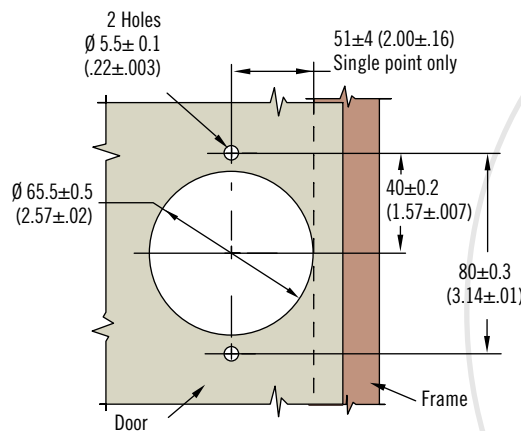

ACTUAL SIZE



R Rotation

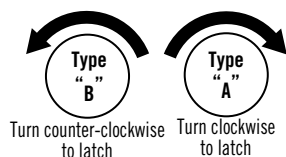

L Lock Styles

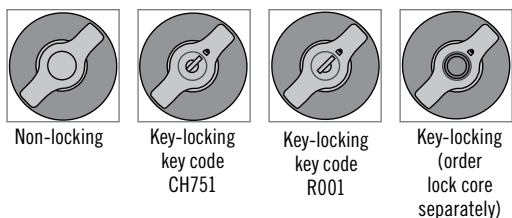

Latch Part Number (no cam)

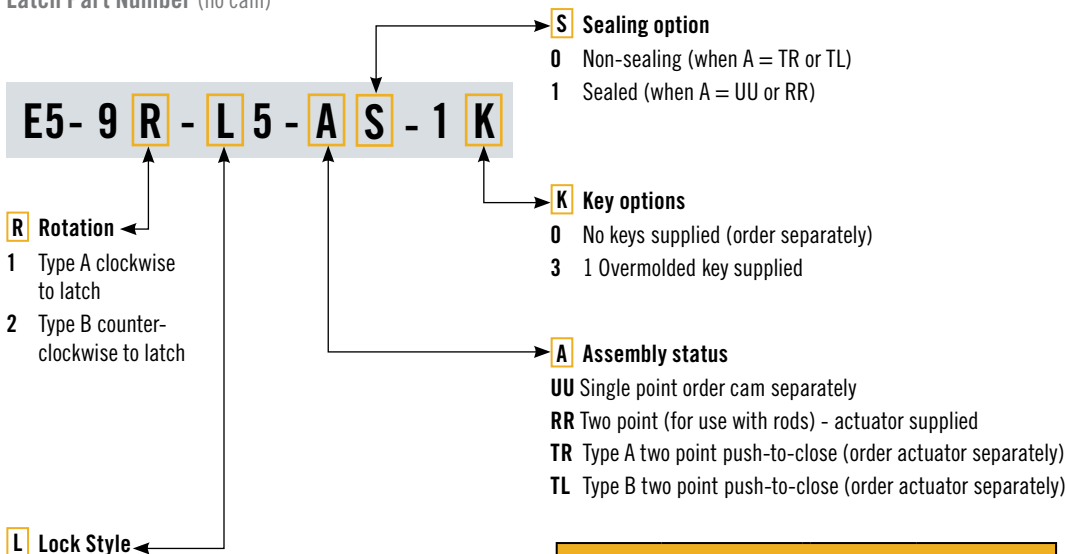

Cam Part Number Table (order separately from latch)

Grip	Part Number	Grip	Part Number
22.7 (.89)	E5-6603	30.7 (1.21)	E5-6607
24.7 (.97)	E5-6604	32.7 (1.29)	E5-6608
26.7 (1.05)	E5-6605	34.7 (1.37)	E5-6609
28.7 (1.13)	E5-6606	36.7 (1.44)	E5-6610

If grip falls between two choices, use the smaller option

Dimensions in millimeters (inch) unless otherwise stated



Part Number Selection

Single point

Order latch and cam separately

Two point (for use with rods)

Order latch only
(two point actuator supplied)

Two point push-to-close action (spring loaded)

Order latch and actuator separately.
Actuator part number A5-91-201-11,
see page 99 for details.

To be used with *SOUTHCO*® R4
rotary series latches and cables
see pages 120 - 131.



E5 Cam Latch

Zinc · L-handle · Hand operated · Fixed grip

- Single hole install
- Multiple key codes

Material and Finish

Zinc alloy, powder coated or chrome plated and steel, zinc plated

Performance Details

Max. static load: 330 N (74 lbf)

Sealing Notes

NEMA 4 / IP65 achieved using gasket supplied

Installation Notes

Mounting nut: Max. tightening torque: 10 N·m (88 in·lbf)

Screw max. tightening torque: 10 N·m (90 in·lbf)

Keys

See page 98

Notes

Suitable for push-to-close action see pages 96 - 97

For lock core selection and a complete overview of the *SOUTHCO*® Key-Choice System see pages 182 - 183

For adjustable grip versions see pages 102 - 103

Part Number Selection

Order latch and cam separately

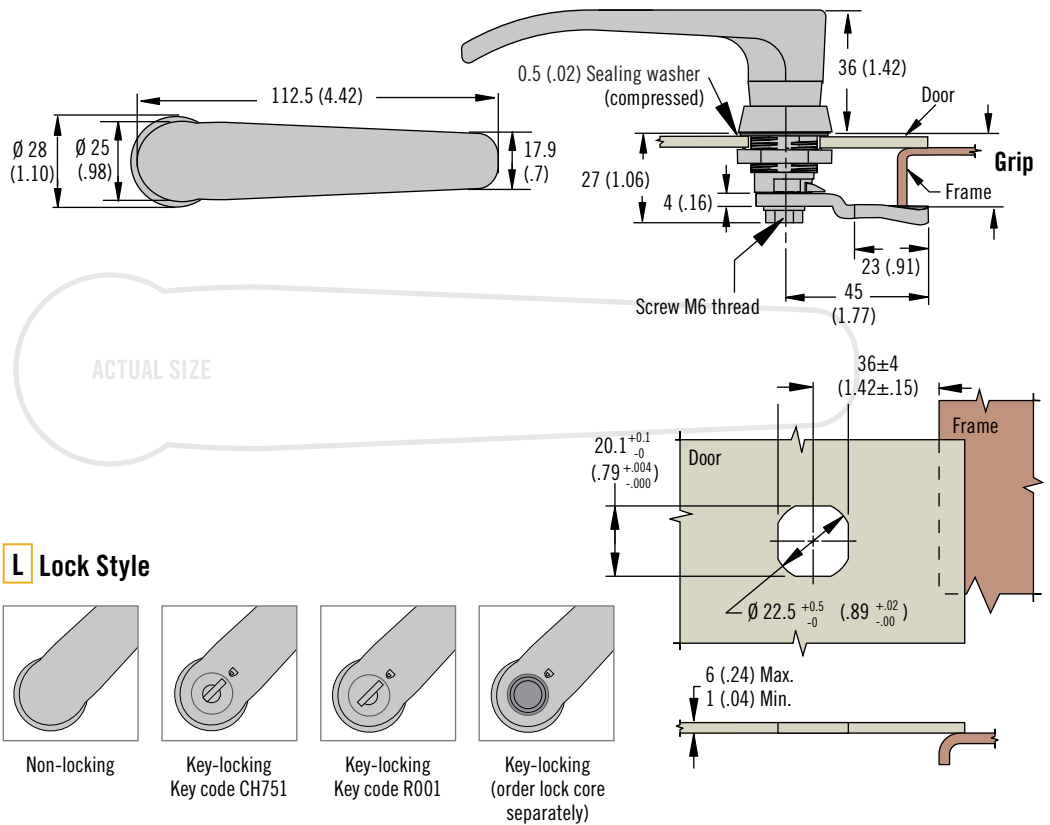

L Latch Part Number (no cam)

F Finish
 2 Bright chrome
 5 Black powder coated

E5 - 9 - L F - UU1 - 1 K

- L Lock style**
- 70 Non-locking (omit last two digits of part number)
 - 71 Keyed CH751 (lock core finish matches handle finish)
 - 72 Keyed R001 (stainless steel scalp shuttered)
 - 73 Without lock core (omit last two digits of part number)
- Order lock core separately, see pages 182 - 183
- K Key options**
- 0 No keys supplied (order separately)
 - 3 1 Overmolded key supplied

Cam Part Number Table (order separately from latch)							
Grip	Part Number	Grip	Part Number	Grip	Part Number	Grip	Part Number
4 (.16)	E5-6003	14 (.55)	E5-6008	24 (.94)	E5-6013	34 (1.34)	E5-6018
6 (.24)	E5-6004	16 (.63)	E5-6009	26 (1.02)	E5-6014	36 (1.42)	E5-6019
8 (.31)	E5-6005	18 (.71)	E5-6010	28 (1.10)	E5-6015	38 (1.50)	E5-6020
10 (.39)	E5-6006	20 (.79)	E5-6011	30 (1.18)	E5-6016	40 (1.57)	E5-6021
12 (.47)	E5-6007	22 (.87)	E5-6012	32 (1.25)	E5-6017	42 (1.65)	E5-6022

If grip falls between two choices, use the smaller option

Dimensions in millimeters (inch) unless otherwise stated



www.southco.com/E5

E5 Cam Latch

Zinc · T-handle · Hand operated · Fixed grip

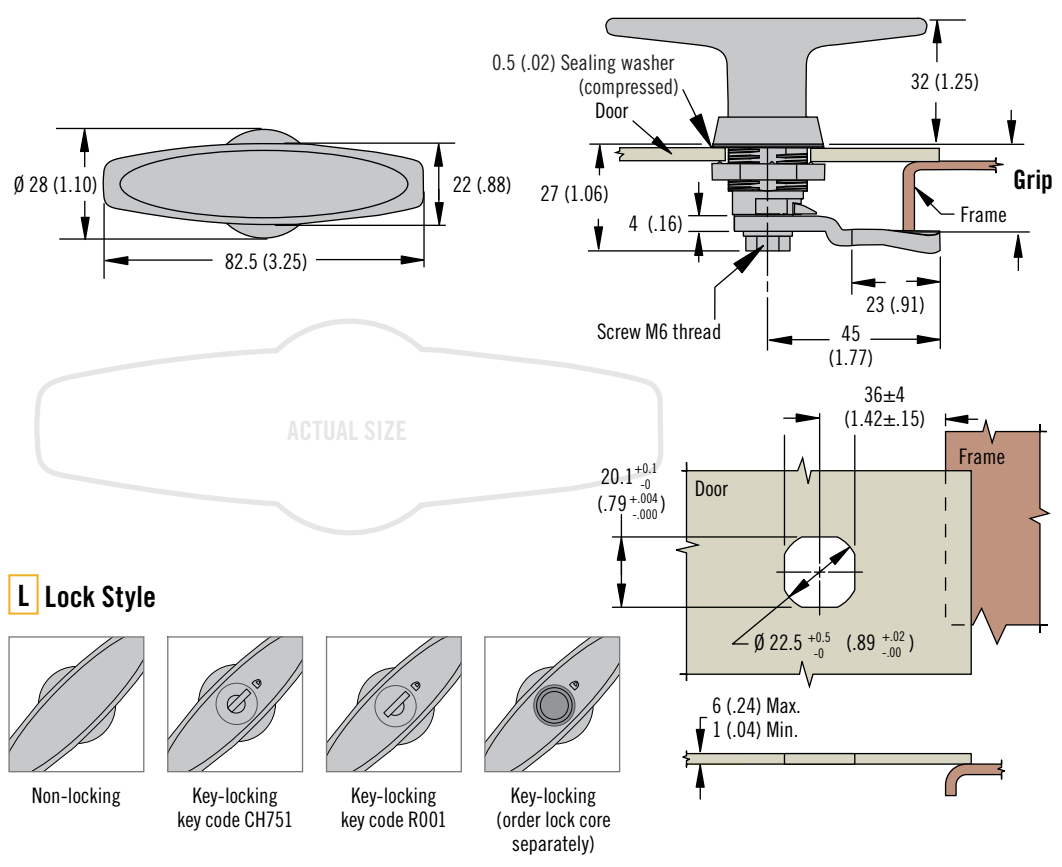

L Lock Style

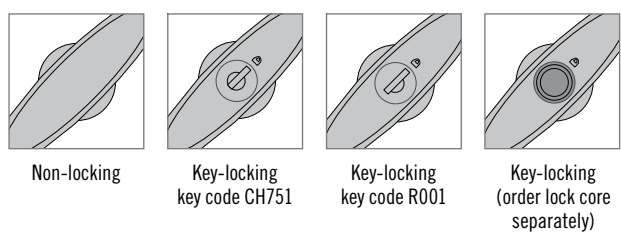

Latch Part Number
(no cam)

E5 - 9 - L F - UU1 - 1 K

L Lock style

- 60 Non-locking (omit last two digits of part number)
- 61 Keyed CH751 (lock core finish matches handle finish)
- 62 Keyed R001 (stainless steel scalp shuttered)
- 63 Without lock core (omit last two digits of part number)
Order lock core separately, see page 182 - 183

F Finish

- 2 Bright chrome
- 5 Black powder coated

K Key options

- 0 No keys supplied (order separately)
- 3 1 Overmolded key supplied

Cam Part Number Table (order separately from latch)							
Grip	Part Number	Grip	Part Number	Grip	Part Number	Grip	Part Number
4 (.16)	E5-6003	14 (.55)	E5-6008	24 (.94)	E5-6013	34 (1.34)	E5-6018
6 (.24)	E5-6004	16 (.63)	E5-6009	26 (1.02)	E5-6014	36 (1.42)	E5-6019
8 (.31)	E5-6005	18 (.71)	E5-6010	28 (1.10)	E5-6015	38 (1.50)	E5-6020
10 (.39)	E5-6006	20 (.79)	E5-6011	30 (1.18)	E5-6016	40 (1.57)	E5-6021
12 (.47)	E5-6007	22 (.87)	E5-6012	32 (1.25)	E5-6017	42 (1.65)	E5-6022

If grip falls between two choices, use the smaller option

Dimensions in millimeters (inch) unless otherwise stated

- Single hole install
- Multiple key codes

Material and Finish

Zinc alloy, powder coated or chrome plated and steel, zinc plated

Performance Details

Max. static load: 330 N (74 lbf)

Sealing Notes

NEMA 4 / IP65 achieved using gasket supplied

Installation Notes

Mounting nut:
Max. tightening torque:
10 N·m (88 in·lbf)

Screw:
Max. tightening torque:
10 N·m (90 in·lbf)

Keys

See page 98

Notes

Suitable for push-to-close action
see pages 96 - 97

For adjustable grip versions see
pages 102 - 103

For lock core selection and a complete overview of the *SOUTHCO*® Key-Choice System see pages 182 - 183

Part Number Selection

Order latch and cam separately



E5 Cam Latch

Zinc · Wing style · Padlockable wing style · Fixed grip

- Single hole install
- Multiple key codes

Material and Finish

Wing: Zinc alloy, black powder coated and steel, zinc plated

Padlockable wing: Zinc alloy, chrome plated and steel, zinc plated

Performance Details

Max. static load: 330 N (74 lbf)

Sealing Notes

Wing style sealed to meet NEMA4 / IP65 standards

Installation Notes

Mounting nut max. tightening torque: 10 N·m (88 in·lbf)

Screw Max. tightening torque: 5 N·m (45 in·lbf)

Keys

See page 98

Notes

Wing style suitable for push-to-close action see pages 96 - 97

For lock core selection and a complete overview of the *SOUTHCO*® Key-Choice System see pages 182 - 183

Part Number Selection

Order latch and cam separately

Cam part number see table page 95

Part Number Selection

Order latch and cam separately

Cam part number see table page 95

Wing

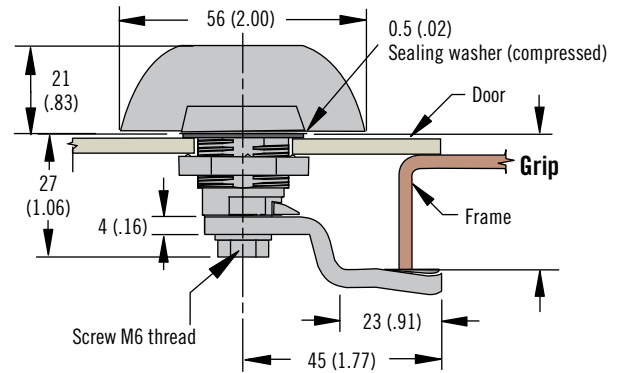
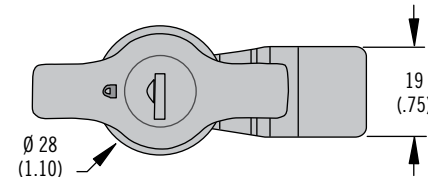

L Lock Styles

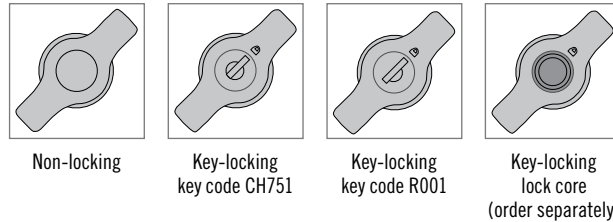

Latch Part Number (no cam)

E5 - 9 - L 5 - UU1 - 1 K

K Key options

- 0 No keys supplied (order separately)
- 3 1 Overmolded key supplied

L Lock style

- 30 Non-locking (omit last two digits of part number)
- 31 Key-locking black lock core keyed alike CH751
- 32 Key-locking stainless steel scalp and shuttered lock core keyed alike R001
- 33 Without lock core (omit last two digits of part number)
Order lock core separately, see pages 182 - 183

Padlockable Wing

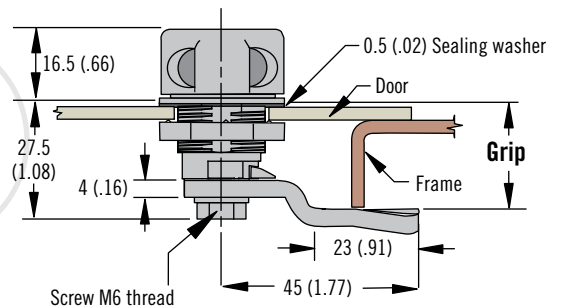
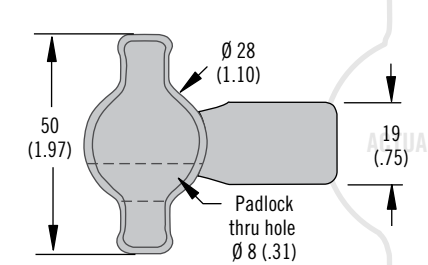

R Rotation

- 1 Type B counter-clockwise to latch
- 2 Type A clockwise to latch

Latch Part Number (no cam)

E5 - 31 - 5 R 2 - UU0



www.southco.com/E5

Dimensions in millimeters (inch) unless otherwise stated

E5 Cam Latch

Zinc · Cylinder lock · Fixed grip



Cylinder Lock

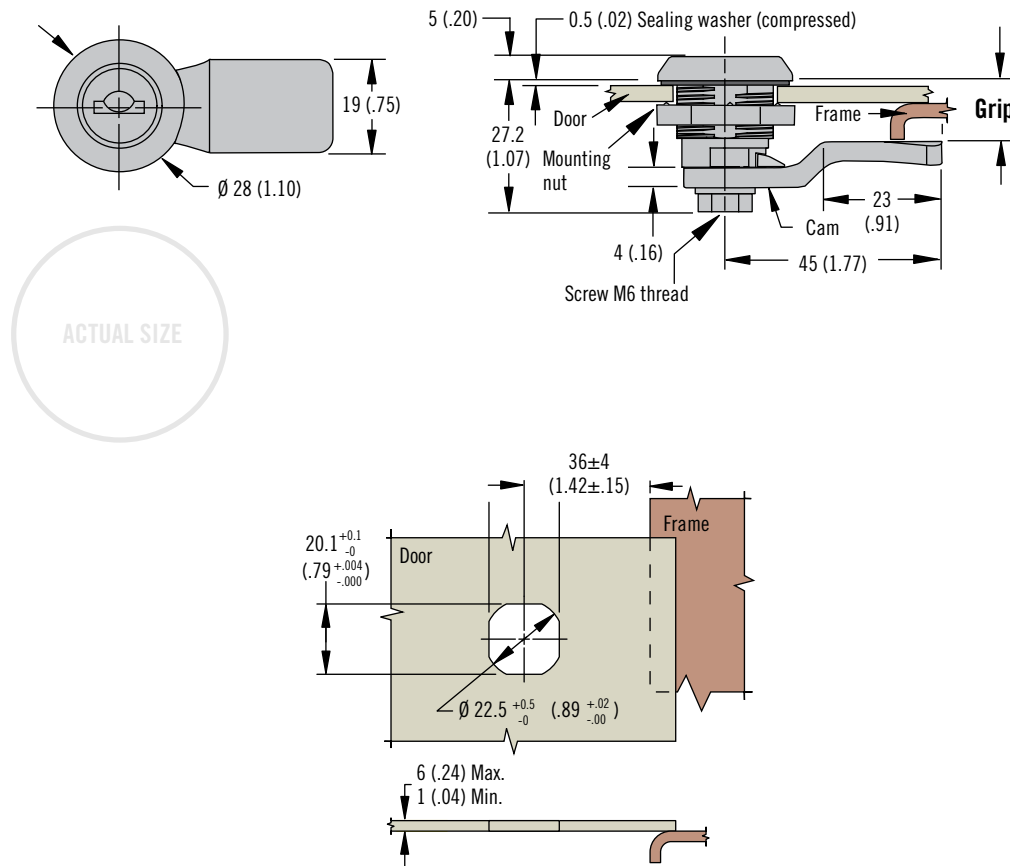

- Single hole install
- Latched / unlatched indicator

Material and Finish

Zinc alloy, powder coated and steel, zinc plated
Scalp stainless steel

Performance Details

Max. static load: 330 N (74 lbf)

Installation Notes

Mounting nut max. tightening torque: 10 N·m (88 in·lbf)

Screw Max. tightening torque: 5 N·m (45 in·lbf)

Sealing Notes

NEMA 4 / IP65 achieved using gasket supplied

Keys and Accessories

See pages 98 - 101

Notes

Suitable for push-to-close action
see pages 96 - 97

- F** Finish
- 2 Bright Chrome
 - 5 Black powder coated

- K** Key options CH751
- 0 No keys supplied (order separately)
 - 2 2 Flat keys supplied

Latch Part Number
(no cam)

E5 - 5 - 40 F - UU1 - 1 K

Part Number Selection

Order latch and cam separately

Cam Part Number Table (order separately from latch)							
Grip	Part Number	Grip	Part Number	Grip	Part Number	Grip	Part Number
4 (.16)	E5-6003	14 (.55)	E5-6008	24 (.94)	E5-6013	34 (1.34)	E5-6018
6 (.24)	E5-6004	16 (.63)	E5-6009	26 (1.02)	E5-6014	36 (1.42)	E5-6019
8 (.31)	E5-6005	18 (.71)	E5-6010	28 (1.10)	E5-6015	38 (1.50)	E5-6020
10 (.39)	E5-6006	20 (.79)	E5-6011	30 (1.18)	E5-6016	40 (1.57)	E5-6021
12 (.47)	E5-6007	22 (.87)	E5-6012	32 (1.25)	E5-6017	42 (1.65)	E5-6022

If grip falls between two choices, use the smaller option



E5 Cam Latch

Zinc · Push-to-close · Hand, key or tool operated · Single and two point

- **Single hole installation**
- **Latched / unlatched indicator**
- **Push-to-close action**

Material and Finish

Zinc alloy, powder coated and steel, zinc plated

Performance Details

Max. static load: 330 N (74 lbf)

Installation Notes

Mounting nut max. tightening torque: 10 N·m (88 in·lbf)

Screw Max. tightening torque: 5 N·m (45 in·lbf) for two point actuator only

Keys and Accessories

See pages 98 - 101

Notes

Single Point: Push-to-close action in unlocked position only or key inserted (cylinder lock)

Two Point: Order actuator separately

For lock core selection and a complete overview of the *SOUTHCO®* Key-Choice System see pages 182 - 183

Actuator Part Number

A5-91-201-11, see page 99 for details

Two point to be used with *SOUTHCO®* R4 rotary series latches and cables see page 120 - 131

Two point push to close action: Internal spring causes return of driver and actuator to original latched position when driver is released after opening. Ideal for use with cables and rotary latches.

Single Point Spring-Loaded (Type A tool operated shown)

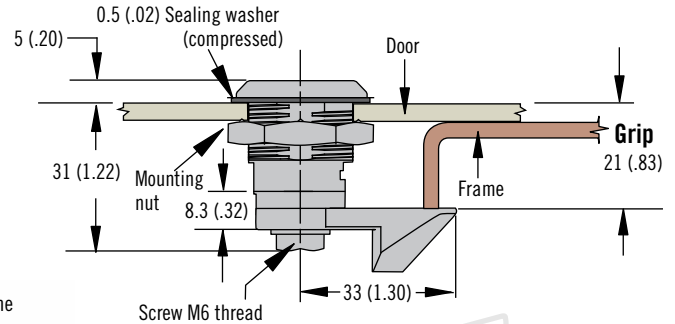
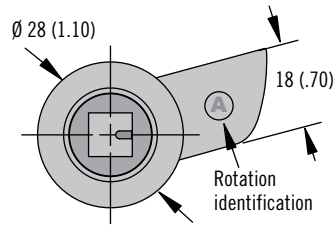

Operation

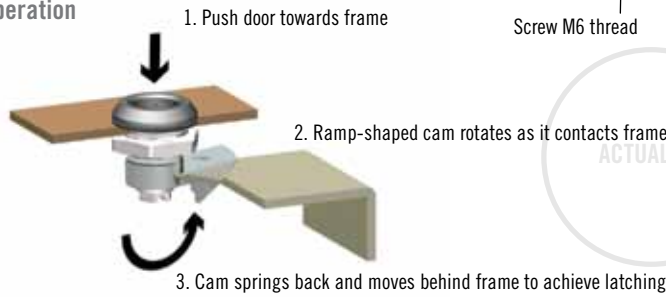

Two Point Spring-Loaded (Type A hand operated shown)

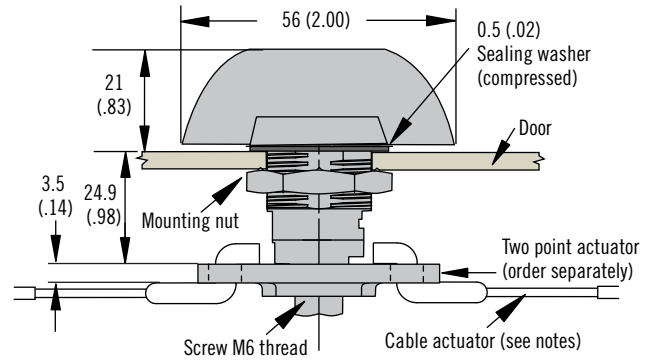
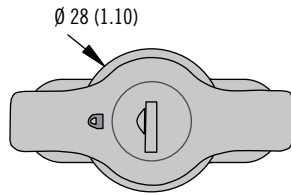

Rotation

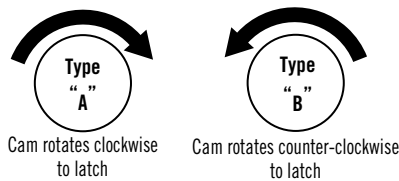

Two Point Actuator

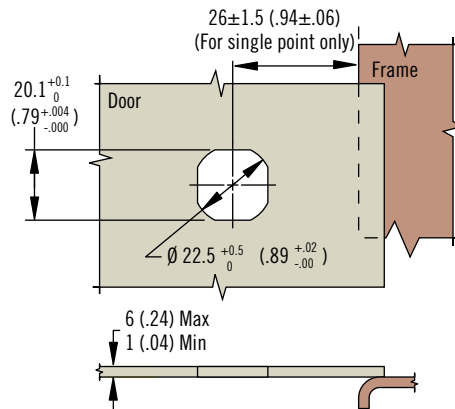
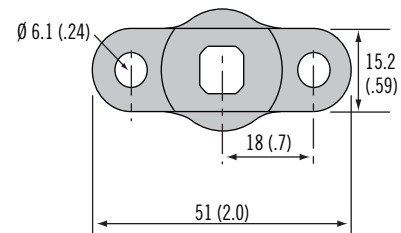

Dimensions in millimeters (inch) unless otherwise stated



www.southco.com/E5

Hand / Key Operated

F Finish

- 2 Bright chrome (not available for wing type)
- 5 Black powder coated

T Type

- 5 Cylinder lock keyed alike CH751
- 9 Wing / T-handle / L-handle

R Rotation

- 51 Type A single point (for visual identification cam stamped A or B)
- 52 Type B single point (for visual identification cam stamped A or B)
- TR Type A two point (order actuator separately)
- TL Type B two point (order actuator separately)





Part Number Selection

Latch supplied fully assembled

K Key options

- 0 No keys supplied (order separately)
- 3 1 Overmolded key supplied

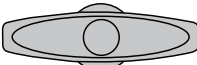
E5 - T - L F - R 0 - 1 K

Lock style	T = 5	T = 9		
				
	Cylinder Lock	Wing	T-handle	L-handle
Non-locking (omit last two digits of part number)	~	30	60	70
Keyed CH751 (lock core finish matches handle finish)	~	31	61	71
Keyed CH751 (stainless steel scalp shuttered)	40	~	~	~
Keyed R001 reversible (stainless steel scalp shuttered)	~	32	62	72
Without lock core (omit last two digits of part number) (to be ordered separately see pages 182 - 183)	~	33	63	73

Tool Operated

H Head Styles

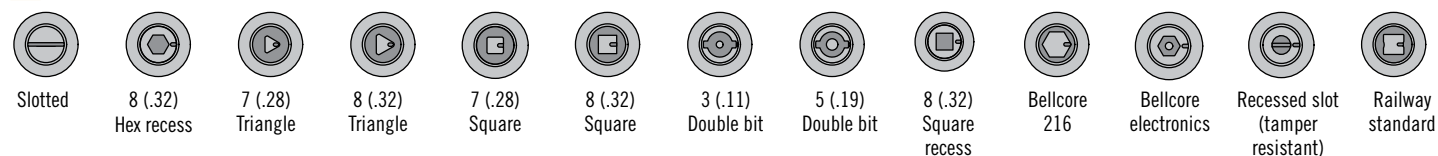

F Finish

- 2 Bright chrome
- 5 Black powder coated

H Head style

- 00 Slotted
- 01 8 (.32) Hex recess
- 02 7 (.28) Triangle
- 03 8 (.32) Triangle
- 04 7 (.28) Square
- 05 8 (.32) Square
- 06 3 (.11) Double bit
- 07 5 (.19) Double bit
- 08 8 (.32) Square recess
- 13 Bellcore 216
- 19 Bellcore electronics
- 21 Recessed slot (tamper resistant)
- 22 Railway standard

R Rotation

- 51 Type A single point (for visual identification cam stamped A or B)
- 52 Type B single point (for visual identification cam stamped A or B)
- TR Type A two point (order actuator separately)
- TL Type B two point (order actuator separately)

Part Number Selection

Latch supplied fully assembled

E5 - 6 - H F - R 0



E5 Cam Latch Accessories

Keys

Material and Finish

Tool key: Zinc alloy or nylon

Overmolded key: Brass plated and ABS plastic black

Flat key: Brass plated

Keys Zinc or Nylon



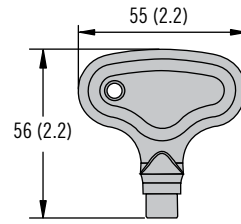







- H** Head style
- 2 3 (.11) Double bit
 - 3 7 (.28) Triangle
 - 4 7 (.28) Square
 - 7 8 (.32) Triangle
 - 8 8 (.32) Square recess
 - 9 5 (.19) Double bit (nylon only)
 - 10 8 (.32) Square male (zinc only)
 - 11 Bellcore electronics
 - 12 Bellcore 216 (zinc only)
 - 24 6 (.24) Square recess (nylon only)

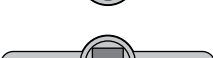

- F** Finish
- 1 Plated zinc
 - 2 Natural zinc
 - 3 Nylon, black



Key Styles

-  2 3 (.11) Double bit
-  3 7 (.28) Triangle
-  4 7 (.28) Square
-  7 8 (.32) Triangle
-  8 8 (.32) Square recess
-  9 5 (.19) Double bit
-  10 8 (.32) Square male
-  11 Bellcore electronics
-  12 Bellcore 216
-  24 6 (.24) Square recess

Part Number

Overmolded key CH751:

Single: PK-10-10-05

Pair: PK-10-01-05

Overmolded key R001:

Single: PK-10-10-05-KR001

Pair: PK-10-01-05-KR001

Flat key

Pair: PK-10-01

Overmolded Keys

Key CH751

Key R001



Flat Keys

Key CH751



Dimensions in millimeters (inch) unless otherwise stated



www.southco.com

E5 Cam Latch Accessories

Multi-point actuators · Hooked cam



Multi-Point Actuator

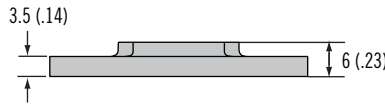
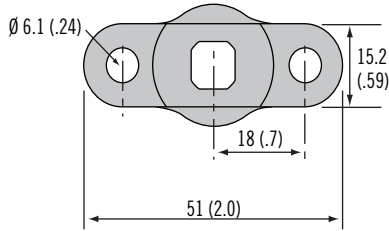

Part Number
A5-91-201-11

Material and Finish

Zinc alloy

Notes

2-Point Actuator plate (for multi-point see pages 264 - 265 for rods) (not recommended for key-locking)
Not to be used with low profile E5

Multi-Point Actuator - Low Profile

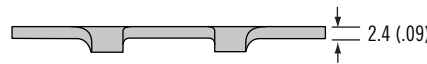
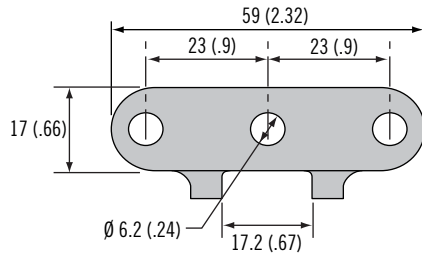

Part Number
A8-4-01-03

Material and Finish

Steel plated

Notes

Actuator plate (for multi-point see pages 264 - 265 for rods)
For use with all E5 latches

Multi-Point Actuator

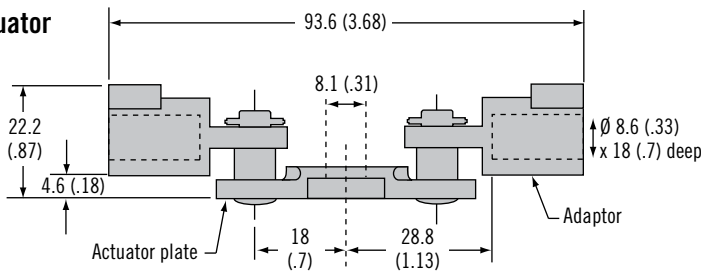

Part Number
A5-90-101-11

Material and Finish

Zinc alloy and steel, zinc plated

Notes

Actuator plate (for multi-point see pages 264 - 265 for rods)
Not to be used with low profile E5

Hooked Cam

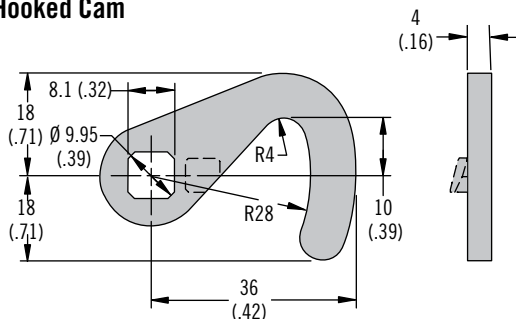

Hooked Cam Part Number	
E5-6200	No stop
E5-6210	Stop for clockwise rotation
E5-6220	Stop for counter-clockwise rotation

Material and Finish

Steel plated

Notes

Not to be used with low profile E5



E5 Cam Latch Accessories

Sealing washer · Sealing cover

Material and Finish

Sealing washer: Neoprene natural

Sealing cover: Thermoplastic elastomer, black

Installation Notes

To provide sealing: use two sealing washers and add compressed thickness of each washer and accessory thickness to your door thickness range.

Notes

Sealing washer for use with all E5 products

Sealing cover for use with tool operated and cylinder lock E5 only

Sealing Washer

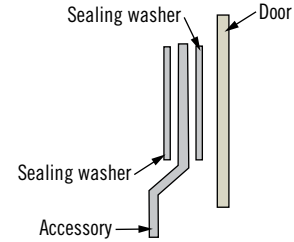
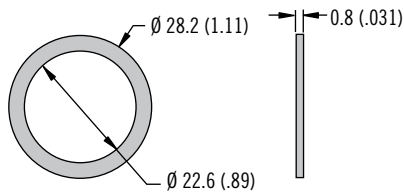

Sealing Cover

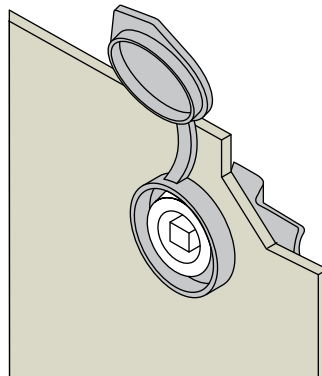
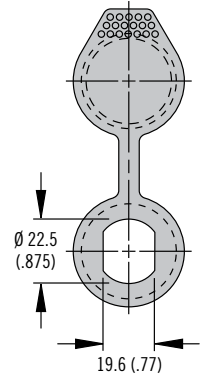
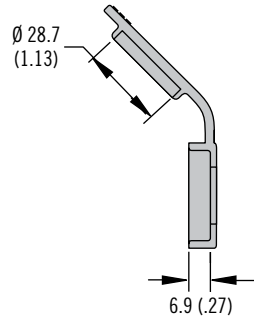
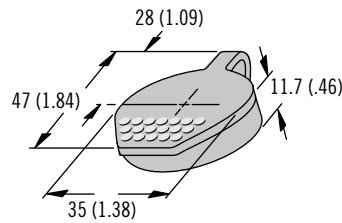

Part Number

See table

Type	Part Number	Adjustment Formula
Sealing washer	E5-17	Add 0.4 (0.02) compressed height to door thickness range
Sealing cover	90-3	Add 2.3 (.090) to door thickness range

Dimensions in millimeters (inch) unless otherwise stated

E5 Cam Latch Accessories

Padlock bracket · Pull tab



Padlock Bracket (Square)

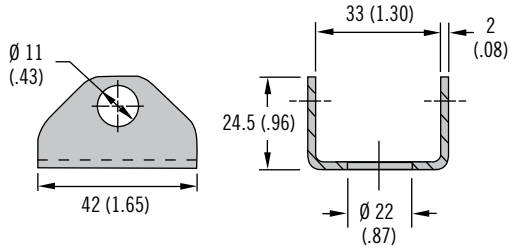

Padlock Bracket (Round)

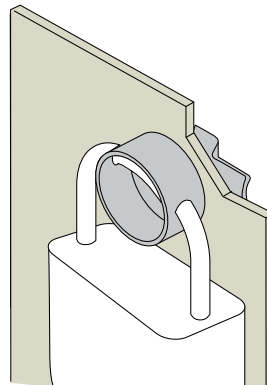
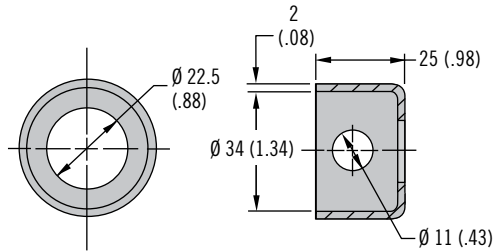

Pull Tab

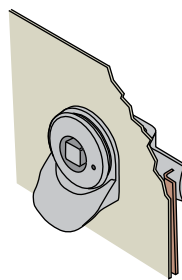
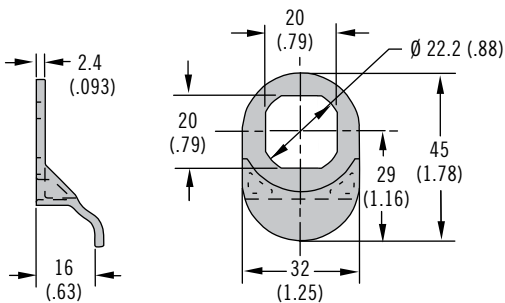

Shown perpendicular to latch and cam

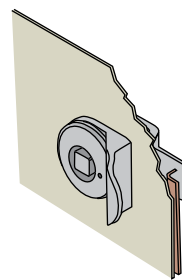

Shown in-line with latch and cam

Material and Finish

Padlock bracket: Stainless steel, black powder coated

Pull tab: Nylon, black

Installation Notes

To provide sealing: use two sealing washers and add compressed thickness of each washer and accessory thickness to your door thickness range.

Notes

Padlock brackets and pull tabs for use with tool operated and cylinder lock E5 only

Type	Part Number	Adjustment Formula
Padlock bracket square	E3-77-101-31	Add 2 (.08) to door thickness range
Padlock bracket round	E3-77-102-31	Add 2 (.08) to door thickness range
Pull tab	E5-18	Add 2.4 (.093) to door thickness range

Part Number

See table

Southco® Pawl/Cam Action Latches

Designer Series, Quad Panel Latches

- Sealed to meet NEMA 4/IP-66 water intrusion standards with optional O-ring/Sealing Washer
- 13 access styles including hand-, tool-, and key-operated
- Latched/unlatched indicator
- Assembled and unassembled styles available
- Single-hole installation

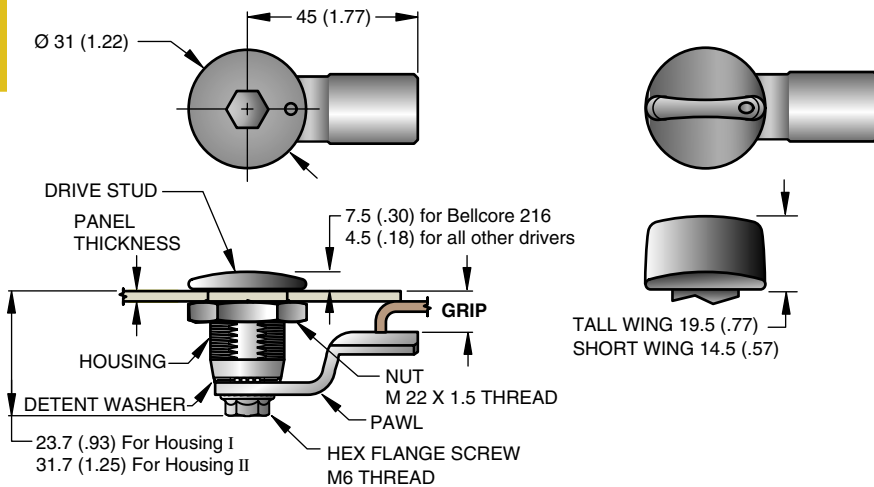

Pawl Detail

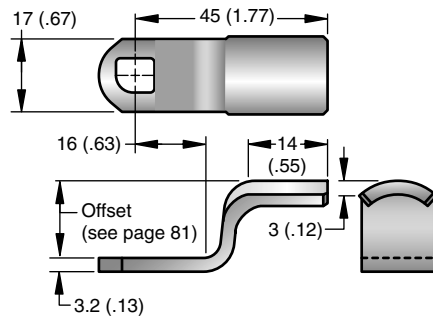

Seals

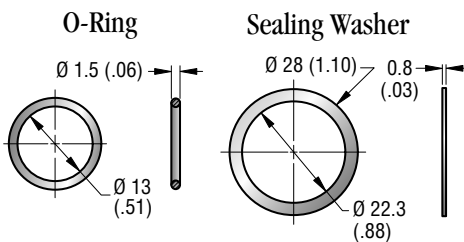

Ordering Options:

Latch Options	Door Thickness	Grip Range
Assembled (see pp.82-83)	1 (.04) - 6 (.24)*	5 (.20) - 44 (1.73) *The grip must exceed door thickness by 4 (.16)
Unassembled (see pp.80-81)	1 (.04) - 14 (.55)	1 (.04) - 44 (1.73)



Industrie
Forum
Design
Hannover

Material and Finish

DRIVE STUDS: (Chrome) Die-cast zinc, chrome plated. (Black) Die-cast zinc, natural; head is black powder coated.

HOUSING: Die-cast zinc, acrylic latex sealer.

PAWL: 1010 steel, zinc plate, chromate plus sealer.

DETENT WASHER: 301 Stainless steel, passivated.

HEX FLANGE SCREW: Low carbon steel, zinc plate, chromate plus sealer.

MOUNTING NUT: Die-cast zinc, zinc plate, bright chromate.

O-RING: Buna-N, black.

Product Strength Guidelines

(To assist in your product selection; samples are available for your evaluation.)

SEALING WASHER: Neoprene, black.

Maximum static load on pawl: 330 N (74 lbs.)

Average ultimate load on pawl: 450 N (101 lbs.)

millimeter (inch)
millimeter
(inch)

Dimensions without tolerances are for reference only.

Quad Panel Latches, (Unassembled Version)

Use in panels 1 mm (.04) - 14 (.55) thick

How to order: A complete assembly consists of one Housing, one Drive Stud and one Pawl, ordered separately. See page 82 to determine your maximum outer door thickness and grip. Use to order components below.

Housing

E 5 - G - V

HOUSING STYLE

- 1 = HOUSING I [For panels 1 (.04) to 6 (.24) thick and grip 1 (.04) to 20 (.79)]
- 2 = HOUSING II [For panels 1 (.04) to 14 (.55) thick and grips 6 (.24) to 44 (1.73)]

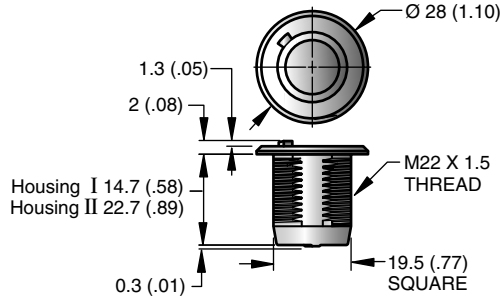

Drive Stud

E 5 - T V - W W X

DRIVE STUD STYLE

- 1 = For use with HOUSING I
- 2 = For use with HOUSING II

HEAD STYLE (see below)

FINISH

- 1 = Textured chrome plate
- 5 = Black powder coat

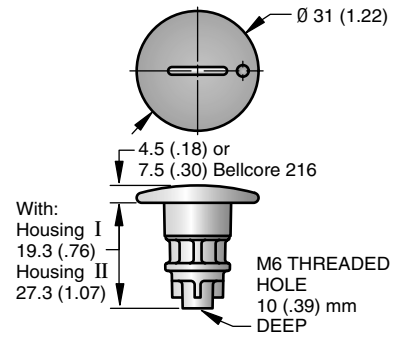
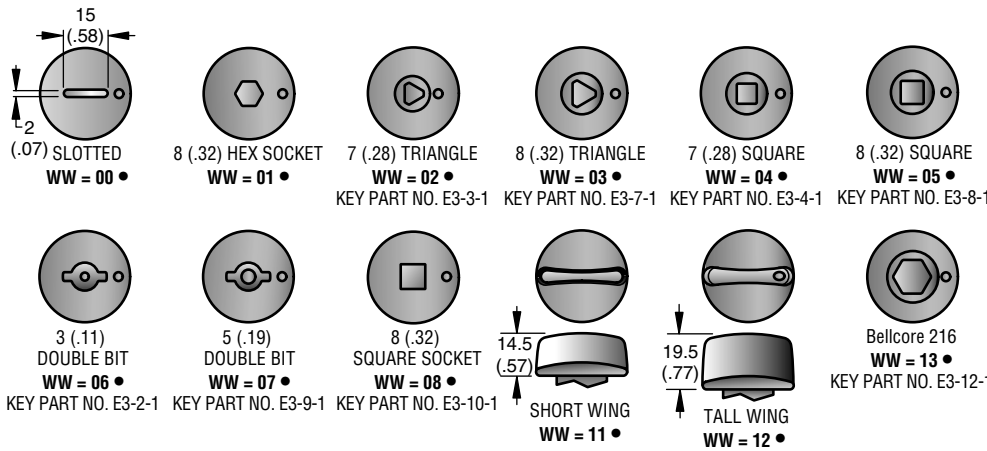

Pawl and Sealing Options (Mounting Hardware package is included with Pawl.)

E 5 - P - Y Y Z

If your grip falls between two choices, use the smaller one.

PAWL TYPE (see below)

SEALING OPTION

0 = No O-ring or sealing washer

1 = O-ring and sealing washer included for NEMA 4/IP-66 rating

Order Pawl Type	YY=00 •	YY=01 •	YY=02 •	YY=03 •	YY=04 •	YY=05 •	YY=06 •	YY=07 •	YY=08 •	YY=09 •	Order Pawl Type
Using HOUSING I	Do Not Use										GRIP
Using HOUSING II	6 (.24)	8 (.31)	10 (.39)	12 (.47)	14 (.55)	16 (.63)	18 (.71)	20 (.79)	22 (.87)	24 (.94)	
Pawl Offset	18 (.71)	16 (.63)	14 (.55)	12 (.47)	10 (.39)	8 (.31)	6 (.24)	4 (.16)	2 (.08)	0 (0)	Pawl Offset
Order Pawl Type	YY=10 •	YY=11 •	YY=12 •	YY=13 •	YY=14	YY=15	YY=16	YY=17	YY=18	YY=19	Order Pawl Type
Using HOUSING I	18 (.71)	20 (.79)	22 (.87)	24 (.94)	26 (1.02)	28 (1.10)	30 (1.18)	32 (1.25)	34 (1.34)	36 (1.42)	GRIP
Using HOUSING II	26 (1.02)	28 (1.10)	30 (1.18)	32 (1.25)	34 (1.34)	36 (1.42)	38 (1.50)	40 (1.57)	42 (1.65)	44 (1.73)	
Pawl Offset	2 (.08)	4 (.16)	6 (.24)	8 (.31)	10 (.39)	12 (.47)	14 (.55)	16 (.63)	18 (.71)	20 (.79)	Pawl Offset

X-ON Electronics

Largest Supplier of Electrical and Electronic Components

Click to view similar products for [southco manufacturer](#):

Other Similar products are found below :

[C5-22-45](#) [E3-13-4](#) [24-20-412-35](#) [E3-59-52](#) [C5-34-35](#) [R4-EM-21-161](#) [44-99-222-71](#) [E3-56-22](#) [MF-02-210-60](#) [EA-A01-001](#) [E3-129-065](#) [C5-41-25](#) [MA-01-220-02-20](#) [E3-15-11](#) [R4-50-42-101-10](#) [E3-56-52](#) [01-13-51](#) [C5-23-45](#) [MA-01-220-01-10](#) [E3-15-12](#) [EA-W52-506-80](#) [97-50-260-11](#) [57-40-702-85](#) [MA-01-320-02-20](#) [C5-41-45](#) [C2-32-101](#) [E5-2-015-040](#) [EM-05-21-101](#) [E3-16-12](#) [AC-C0H0-4-0250-048](#) [E3-109-045](#) [N2-2-300-01-20](#) [E3-113-95](#) [44-T-1](#) [E3-31-31](#) [AC-C0H0-4-1250-048](#) [EM-05-11-100](#) [F6-23-S16AW](#) [68-50-301-20](#) [E3-122-045](#) [E3-105-075](#) [E5-9014](#) [P8-096-31-M4-11-3](#) [82-15-400-16](#) [PK-24-01](#) [R4-10-41-201-10](#) [97-50-230-12](#) [TM-10-101-24](#) [E3-38-25](#) [E3-105-095](#)