



720 TFX Series Sealed and Rugged Keypads

These tough, water resistant keypads feature moving, tactile keys with a responsive 'over-centre' action and are designed for use in harsh industrial environments. High contrast white keytops are permanently laser engraved with black characters.



The keypad can be installed on the surface or under the panel.
 (Underpanel Installation Instructions are in the Underpanel Fitting Kit)
 Fit the supplied silicone seal into the seal groove on the keypad
 Use the groove on top for underpanel, and on back for surface fix.
 The wide part of the seal goes into the groove – see picture below of the seal fitted to the back of the keypad.

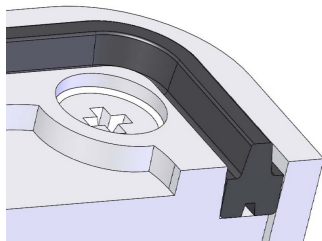

Connection Details

Connection Details for 4 Key Keypad

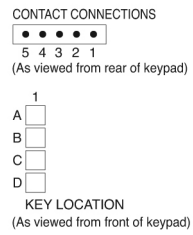

CONTACT MATRIX	
CONNEX. PIN	ROW/ COLUMN
1	common
2	D
3	C
4	B
5	A

Connection Details for 12 Key Keypad

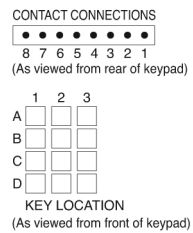

CONTACT MATRIX	
CONNEX. PIN	ROW/ COLUMN
1	A
2	B
3	1
4	2
5	3
6	-
7	D
8	C

Connection Details for 16 Key Keypad

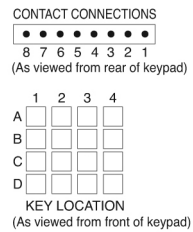

CONTACT MATRIX	
CONNEX. PIN	ROW/ COLUMN
1	A
2	B
3	1
4	2
5	3
6	4
7	D
8	C

Electrical

Contact Bounce	5 ms (max)
Contact Resistance	100 ohms (max)
Insulation Resistance	50 Mohms (min)
Breakdown Voltage	500 V AC (max 60 secs.)
Switch Rating	24V DC 50mA (max)
Connection	X-Y Matrix

Mechanical

Operational Life	2 million cycles (min) per key
Keytop Travel	1.4mm nominal
Actuation Force	150 grams nominal
Connector	0.1"pitch, gold plated square pin
Mating Connector	Molex 2695 Series or equivalent

Performance

Operational Temp	-20°C to 60°C
Impact Rating	5 J
Vibration/Shock	ETSI 300 019 5M3
Water / Dust sealed	IP65 (when fixed to suitable panel)

Part Numbers

7203-04C020	720TFX SERIES 4 KEY
7203-12T020	720TFX SERIES 12 KEY
7203-16T020	720TFX SERIES 16 KEY
7200-FK020	UNDERPANEL FITTING KIT

Accessories

4200-00	RS232 Encoder Interface Module
4500-00	450 USB Encoder Interface Module
4500-10	450i USB Encoder Interface Module with Buzzer and Illumination Control
Replacement Seals --	go to www.storm-interface.com

Dimensions

Overall sizes	See following page.
Panel Cutout DXF	Download .dxf and .stp files from
Surface Model STEP	www.storm-interface.com



Install the keypad onto the surface of a panel as follows :-

- Fit the seal to the rear of the keypad
- Place the keypad onto the panel and fit the self locking nuts to the studs on the back
- Recommended tightening torque 50Ncm

Side View : 4, 12, 16

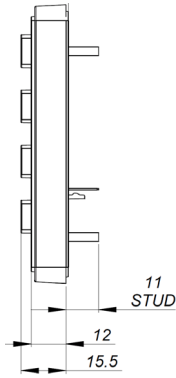

Front and Back View : 4 way

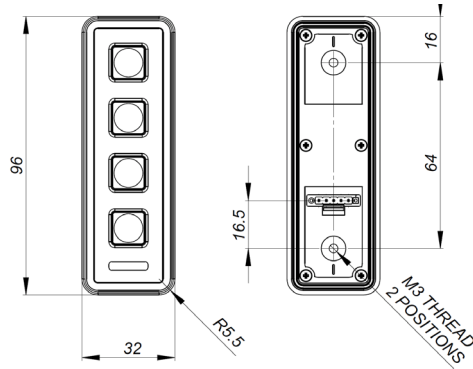

Panel Cutout : 4 way

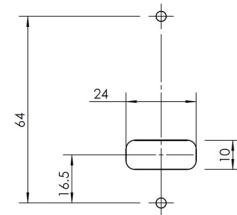

Front and Back View, 12 way

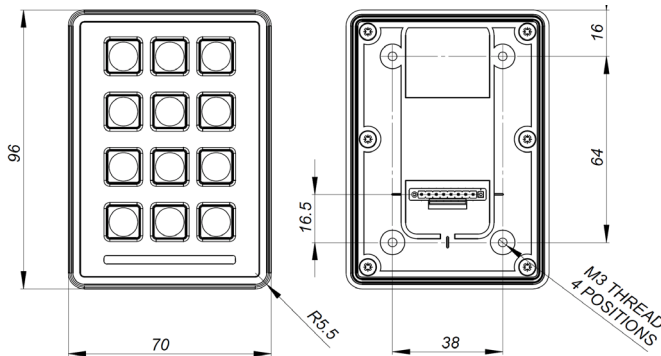

Panel Cutout : 12 way

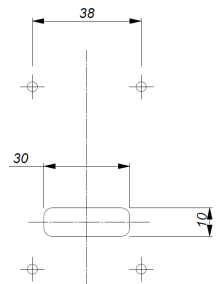

Front and Back View, 16 way

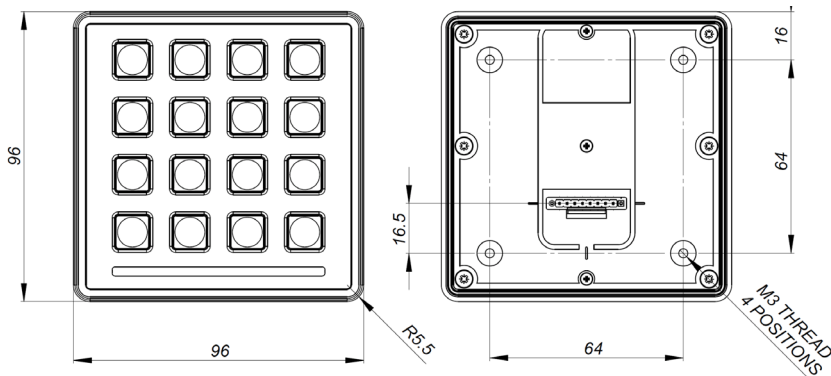

Panel Cutout : 16 way

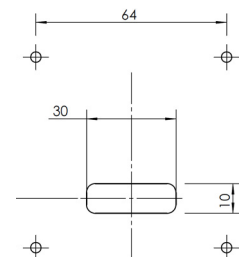

All panel dims in mm.
Corner Rads all M3

X-ON Electronics

Largest Supplier of Electrical and Electronic Components

Click to view similar products for [storm interface manufacturer](#):

Other Similar products are found below :

[1605-330013](#) [FT1K0503](#) [3K042103](#) [3KLW041103](#) [7207-0410203](#) [7207-121W203](#) [GS000201](#) [3KLW120101](#) [2210-452223](#) [EZB6-430003](#)
[PLX041203](#) [DEEX0103](#) [DEGL12003](#) [1K042103](#) [2K120103](#) [4500-003](#) [DE1KT103](#) [DE2KT103](#) [WE2KT103](#) [8616-310023](#) [7203-12T0203](#)
[1200-MK0003](#) [DEL6003](#) [PLX120203](#) [2K12T103](#) [5100-1003](#) [5103-1003](#) [8616-210023](#) [RC120201](#) [DR2KW203](#) [EZB2-505H03](#) [EZB6-](#)
[530023](#) [EZB2-405003](#) [6000-210023](#) [FT1K0803](#) [FT4K0903](#) [EZ08-23001](#) [FT4K1003](#) [2200-003003](#) [3K160103](#) [5100-0003](#) [5100-FK03](#) [5103-](#)
[0103](#) [DXPS1W303](#) [7202-16T0203](#) [8600-MK0003](#) [WE1KT103](#) [DEL12003](#) [EZB6-630023](#) [EZB6-630003](#)