

FEATURES

- Lever ratio: 4.17
- Tab A option, initiates retain-er release action
- Maximum extraction force per extractor obtained with 20 pounds finger force=50 pounds; for standard and 6061-T6 Aluminum Alloy

APPLICATIONS

- Use with Series 24 Lok-Tainer™ Retainer
- Series 27 Lok-Tainer™ requires bent leg option of -1 and -2 PCB's, also 127-2 Series

Meets the requirements of drawing 84191, Defense Supply Center, Columbus (DSCC)

WEIGHT

- .05 ounce Aluminum
- .15 ounce Stainless Steel

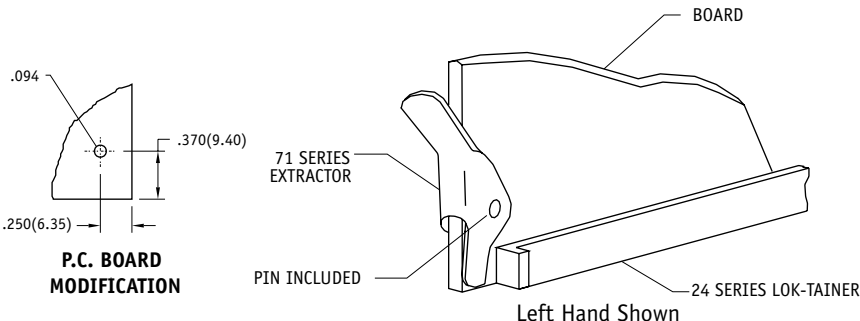

P.C. BOARD MODIFICATION

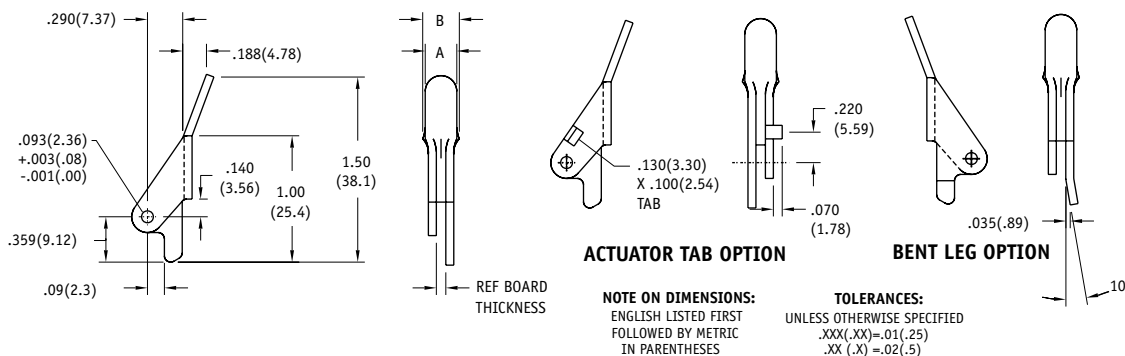

Part Number code

Series 71 Extractor x 71 -x -x -x -x -x -x

Straight Handle option

Select option (blank for none) S

Material

Select From Materials Table ②

Board Thickness

Select dash number from Board Thickness Table ③

Hand Action

Left hand action (see reference diagram on pg.28) L
Right hand action (see reference diagram on pg.28) R

Actuator Tab option

Select option (Blank for none) A

Finish

Select dash number from Finish Table ①

Bent Leg option

Select option (Blank for none) BL

ESD Symbol

E

① FINISH TABLE

COLORS ARE AN ADDITIONAL CHARGE

DASH #	FINISH	COLOR
-1	ANODIZE PER MIL-A-8625	RED
-2	ANODIZE PER MIL-A-8625	BLUE
-3	ANODIZE PER MIL-A-8625	GREEN
-4	ANODIZE PER MIL-A-8625	YELLOW
-5	ANODIZE PER MIL-A-8625	BLACK
-6	ANODIZE PER MIL-A-8625	ORANGE
-7	ANODIZE PER MIL-A-8625	PURPLE
-8	ANODIZE PER MIL-A-8625	GRAY
-9	ANODIZE PER MIL-A-8625	BROWN
-10	ANODIZE PER MIL-A-8625	CLEAR
-CC	CHEM FILM PER MIL-C-5541	CLEAR
NONE	CHEM FILM PER MIL-C-5541	GOLD

② MATERIALS TABLE

DASH #	MATERIAL
NONE	.063 ALUMINUM ALLOY 5052-H32 PER QQ-A-250/8
T6	.063 ALUMINUM ALLOY 6061-T6
CR	.063 STAINLESS STEEL (-2 BOARD THICKNESS ONLY)

③ BOARD THICKNESS TABLE

DASH #	THICKNESS	A	B
-1	.031(0.787)	.25(6.35)	.26(6.60)
-2	.063(1.600)	.25(6.35)	.29(7.37)
-3	.094(2.390)	.25(6.35)	.29(7.37)
-4	.125(3.180)	.29(7.37)	.33(8.38)
-5	.156(3.960)	.29(7.37)	.33(8.38)

X-ON Electronics

Largest Supplier of Electrical and Electronic Components

Click to view similar products for [apw manufacturer](#):

Other Similar products are found below :

[050613B](#) [22-0239](#) [026873F](#) [127B-2-16-3-R](#) [127B-2-12-3-L](#) [71-2-R](#)