

TR FASTENINGS
UNCONTROLLED COPY

TABLE 4A. RECESSED PAN HEAD MACHINE SCREWS.
METRIC SERIES

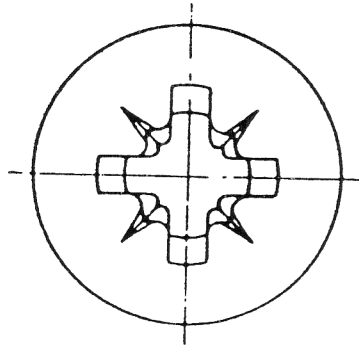
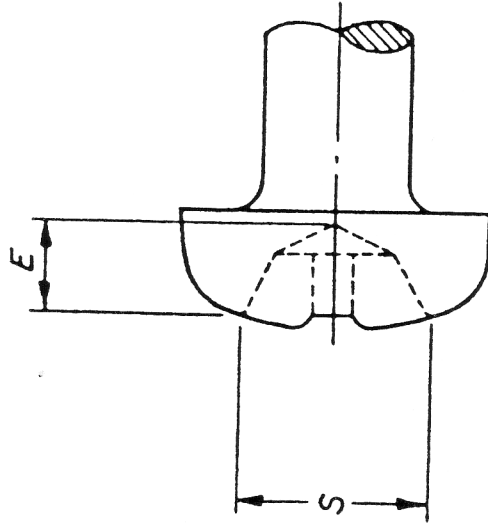

Enlarged view of recessed head

Dimensions in millimetres

		1	2	3	4	5	6	7
Recessed beads								
<i>d</i>	<i>E</i>	Depth of recess		Penetration*		Recess diameter		Recess and driver point number
		Max.	Min.	Max.	Min.	Nom.		
M2.5		1.85	1.44	1.57	1.16	2.64		1
M3		2.11	1.70	1.83	1.42	2.89		1
(M3.5)		2.34	1.88	1.93	1.47	3.91		2
M4		2.72	2.26	2.31	1.85	4.27		2
(M4.5)		2.92	2.46	2.51	2.05	4.47		2
M5		3.10	2.64	2.72	2.26	4.67		2
M6		4.06	3.60	3.51	3.05	6.76		3
M8		4.85	4.39	4.17	3.71	8.46		4
M10		6.40	5.94	5.72	5.26	9.96		4

NOTE. Nominal thread diameters shown in brackets are non-preferred.
• See Appendix A.

X-ON Electronics

Largest Supplier of Electrical and Electronic Components

Click to view similar products for [nettlefolds](#) manufacturer:

Other Similar products are found below :

[SEM03030006FA](#) [SEM03040012FA](#) [SEM03040006FA](#)