



Monitoring relays - GAMMA series

Multifunction

Secure isolation of the measuring circuit

2 change-over contacts

Width 22.5mm

Industrial design



Technical data

1. Functions

Level monitoring of conductive liquid, timing for tripping delay and turn-off delay separately adjustable and the following functions (selectable by means of rotary switch)

Pump up pump up or minimum monitoring
Pump down pump down or maximum monitoring

2. Time ranges

	Adjustment range	
Tripping delay (Delay ON):	0.5s	10s
Turn-off delay (Delay OFF):	0.5s	10s

3. Indicators

Green LED ON: indication of supply voltage
Yellow LED ON/OFF: indication of relay output

4. Mechanical design

Self-extinguishing plastic housing, IP rating IP40
Mounted on DIN-Rail TS 35 according to EN 60715
Mounting position: any
Shockproof terminal connection according to VBG 4 (PZ1 required), IP rating IP20
Tightening torque: max. 1Nm
Terminal capacity:
1 x 0.5 to 2.5mm² with/without multicore cable end
1 x 4mm² without multicore cable end
2 x 0.5 to 1.5mm² with/without multicore cable end
2 x 2.5mm² flexible without multicore cable end

5. Input circuit

Supply voltage:
24V AC terminals A1-A2 (G2LM20 24VAC)
110V AC terminals A1-A2 (G2LM20 110VAC)
230V AC terminals A1-A2 (G2LM20 230VAC)
Tolerance:
24V AC -15% to +10% (G2LM20 24VAC)
110V AC -15% to +10% (G2LM20 110VAC)
230V AC -15% to +15% (G2LM20 230VAC)
Rated frequency: 48 to 63Hz
Rated consumption:
24V AC 2VA (1.5W) (G2LM20 24VAC)
110V AC 2VA (1.5W) (G2LM20 110VAC)
230V AC 2VA (1.5W) (G2LM20 230VAC)
Duration of operation: 100%
Reset time: 500ms
Residual ripple for DC: -
Drop-out voltage: >30% of the supply voltage
Overvoltage category: III (in accordance with IEC 60664-1)
Rated surge voltage: 4kV

6. Output circuit

2 potential free change-over contacts
Rated voltage: 250V AC
Switching capacity: 750VA (3A / 250V)
If the distance between the devices is less than 5mm!
Switching capacity: 1250VA (5A / 250V)
If the distance between the devices is greater than 5mm!

Fusing: 5A fast acting
Mechanical life: 20 x 10⁵ Operations
Electrical life: 2 x 10⁵ Operations at 1000VA resistive load
Switching frequency: max. 60/min at 100VA resistive load
max. 6/min at 1000VA resistive load
(in accordance with IEC 60947-5-1)
Overvoltage category: III (in accordance with IEC 60664-1)
Rated surge voltage: 4kV

7. Measuring circuit

Input: conductive probes (type SK1, SK2, SK3)
 terminals E1-E2-E3
Sensitivity: 0.25 to 100kΩ (4mS to 10μS)
Sensor voltage: 12V AC
Sensor current: max. 7mA
Wiring distance (capacity of cable 100nF/km):
max. 1000m (set value <50%)
max. 100m (set value 100%)
Overvoltage category: III (in accordance with IEC 60664-1)
Rated surge voltage: 6kV

8. Accuracy

Base accuracy: -
Adjustment accuracy: -
Repetition accuracy: -
Voltage influence: -
Temperature influence: -

9. Ambient conditions

Ambient temperature: -25 to +55°C (in accordance with IEC 60068-1)
 -25 to +40°C (in accordance with UL 508)
Storage temperature: -25 to +70°C
Transport temperature: -25 to +70°C
Relative humidity: 15% to 85%
 (in accordance with IEC 60721-3-3 class 3K3)
Pollution degree: 3 (in accordance with IEC 60664-1)
Vibration resistance: 10 to 55Hz 0.35mm
 (in accordance with IEC 60068-2-6)
Shock resistance: 15g 11ms
 (in accordance with IEC 60068-2-27)

Functions

Pump up

Connection of the probe rods E1, E2 and E3. Alternatively the electrically conducting container can be connected in lieu of the test probe E3. When the air-fluid level falls below the minimum probe E2 the set interval of the tripping delay (DELAY ON) begins. After the expiration of the interval the output relays switch into on-position (yellow LED illuminated). When the air-fluid level again rises above the maximum probe E1, the set interval of the turn-off delay (DELAY OFF) begins. After the expiration of the interval the output relays switch into off-position (yellow LED not illuminated).

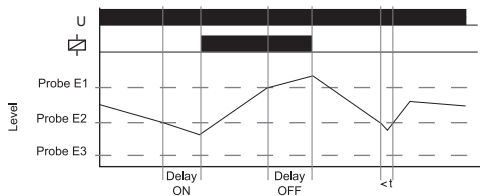

Minimum monitoring (Pump up)

Connection of probe rods E2 and E3 (Bridge E1-E3). Alternatively the electrically conducting container can be connected in lieu of the test probe E3. When the air-fluid level falls below the probe E2 the set interval of the tripping delay (DELAY ON) begins. After the expiration of the interval the output relays switch into on-position (yellow LED illuminated). When the air-fluid level again rises above the probe E2, the set interval of the turn-off delay (DELAY OFF) begins. After the expiration of the interval the output relays switch into off-position (yellow LED not illuminated).

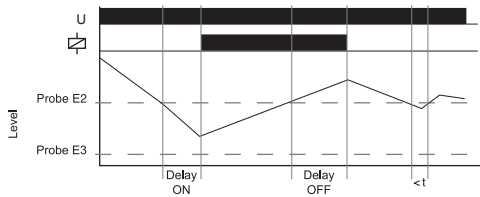

Pump down

Connection of the probe rods E1, E2 and E3. Alternatively the electrically conducting container can be connected in lieu of the test probe E3. When the maximum probe E1 gets moistened the set interval of the tripping delay (DELAY ON) begins. After the expiration of the interval the output relays switch into on-position (yellow LED illuminated). When the air-fluid level falls below the minimum probe E2, the set interval of the turn-off delay (DELAY OFF) begins. After the expiration of the interval the output relays switch into off-position (yellow LED not illuminated).

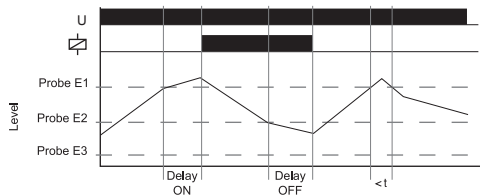

Maximum monitoring (Pump down)

Connection of probe rods E2 and E3 (Bridge E1-E3). Alternatively the electrically conducting container can be connected in lieu of the test probe E3. When the probe E2 gets moistened the set interval of the tripping delay (DELAY ON) begins. After the expiration of the interval the output relays switch into on-position (yellow LED illuminated). When the air-fluid level sinks below the probe E2, the set interval of the turn-off delay (DELAY OFF) begins. After the expiration of the interval the output relays switch into off-position (yellow LED not illuminated).

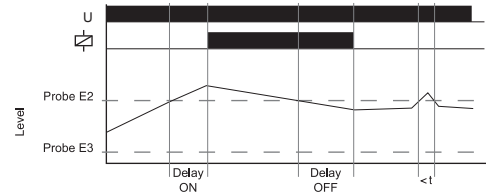

Note

Use cables with low capacity for wiring the probes especially with extended wiring length.

Following processes are suggested for the adjustment:

- The existent time delay should be to minimum (0,5s).
- The function selector switch must be in position pump down.
- Turn the sensitivity controller slowly clockwise from min to max until the relais switch into on-position. (probes must be in dipped state)
- The moistened probes should be taken out of the liquid to control if the relais switch into off-position. If the relais doesn't switch into off-position, turn the sensitivity controller slightly back to min. (counterclockwise)
- Set the existent time delay to desired value to fade out a short term moisten the probes by waves in the liquid.
- Set the function selector switch to desired position. (either pump up or pump down)

Connections

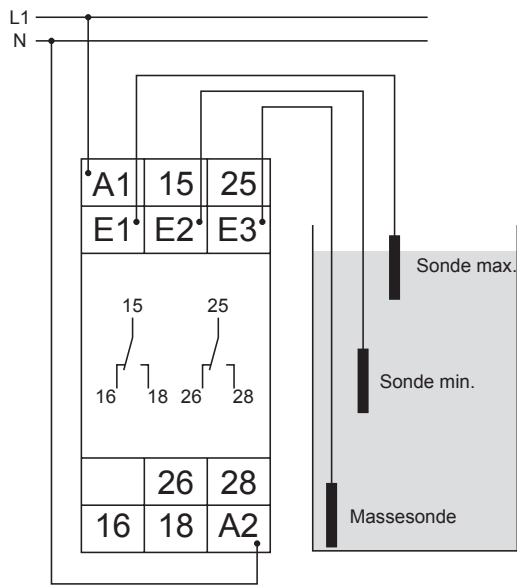

Dimensions

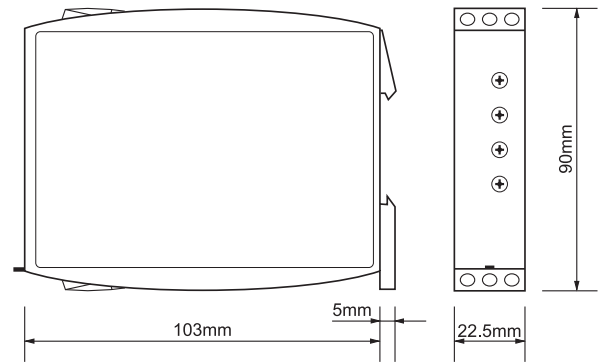

X-ON Electronics

Largest Supplier of Electrical and Electronic Components

Click to view similar products for [tele manufacturer](#):

Other Similar products are found below :

[G2PF400VS02](#) [G2PM400VSY20 24-240VAC/DC](#) [E1ZM10 12-240VAC/DC](#)