

# TS78L00 Series

## 3-Terminal 100mA Positive Voltage Regulator

### TO-92

#### Pin Definition:

1. Output
2. Ground
3. Input



### SOT-23

#### Pin Definition:

1. Output
2. Input
3. Ground



### SOP-8

#### Pin Definition:

1. Output
2. Ground
3. Ground
4. N/C

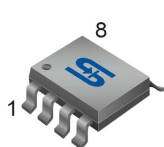

### SOT-89

#### Pin Definition:

1. Output
2. Ground
3. Input

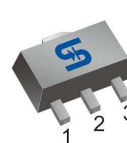

## General Description

The TS78L00 Series of positive voltage Regulators are inexpensive, easy-to-use devices suitable for a multitude of applications that require a regulated supply of up to 100mA. Like their higher power TS7800 and TS78M00 Series cousins, these regulators feature internal current limiting and thermal shutdown making them remarkably rugged. No external components are required with the TS78L00 devices in many applications.

These devices offer a substantial performance advantage over the traditional zener diode-resistor combination, as output impedance and quiescent current are substantially reduced.

## Features

- Output Voltage Range 3.3 to 24V
- Output current up to 100mA
- No external components required
- Internal thermal overload protection
- Internal short-circuit current limiting
- Output transistor safe-area compensation
- Output voltage offered in 4% tolerance

## Standard Application Circuit

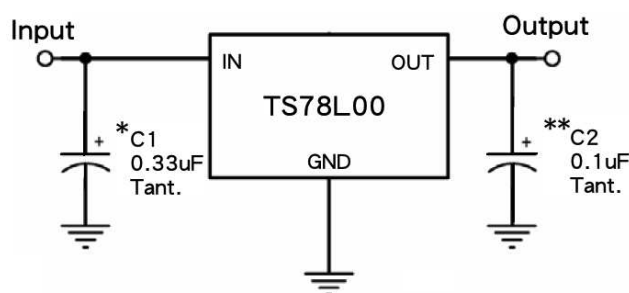

A common ground is required between the input and the output voltages. The input voltage must remain typically 2.0V above the output voltage even during the low point on the Input ripple voltage.

XX = these two digits of the type number indicate voltage.

\* = Cin is required if regulator is located an appreciable distance from power supply filter.

\*\* = Co is not needed for stability; however, it does improve transient response.

## Ordering Information

Part No.	Package	Packing
TS78LxxCT B0	TO-92	1kpcs / Bulk
TS78LxxCT A3	TO-92	2kpcs/ Ammo
TS78LxxACY RM	SOT-89	1kpcs / 7" Reel
TS78LxxCS RL	SOP-8	2.5kpcs / 13" Reel
TS78LxxCX RF	SOT-23	3kpcs / 7" Reel

**Note:** Refer to detail ordering information table.

## Absolute Maximum Ratings (T<sub>A</sub> = 25°C unless otherwise noted)

Parameter	Symbol	Limit	Unit
DC Input Voltage	V <sub>IN</sub>	30	V
		35	
		40	
Power Dissipation	P <sub>D</sub>	Internal Limited	W
Operating Junction Temperature Range	T <sub>J</sub>	0 ~ +150	°C
Storage Temperature Range	T <sub>STG</sub>	-65~+150	°C

### Thermal Performance

Parameter	Symbol	Limit	Unit	
Thermal Resistance - Junction to Case	$R_{\theta JC}$	TO-92	--	$^{\circ}C/W$
		SOT-23	120	
		SOT-89	15	
		SOP-8	20	
Thermal Resistance - Junction to Ambient	$R_{\theta JA}$	TO-92	230	$^{\circ}C/W$
		SOT-23	330	
		SOT-89	55	
		SOP-8	55	

**Note:** Considering 6 cm<sup>2</sup> of copper board heat-sink

### TS78L03 Electrical Characteristics

( $V_{IN}=8.3V$ ,  $I_{OUT}=40mA$ ,  $0^{\circ}C \leq T_J \leq 125^{\circ}C$ ,  $C_{IN}=0.33\mu F$ ,  $C_{OUT}=0.1\mu F$ ; unless otherwise specified.)

Parameter	Symbol	Test Condition	Min	Typ	Max	Unit
Output voltage	$V_{OUT}$	$T_J=25^{\circ}C$	3.173	3.3	3.432	V
		$5.8V \leq V_{IN} \leq 20V$ , $5mA \leq I_{OUT} \leq 100mA$	3.142	3.3	3.465	
Line Regulation	$REG_{LINE}$	$T_J=25^{\circ}C$ $5.8V \leq V_{IN} \leq 20V$ $I_{OUT}=40mA$	--	50	150	mV
Load Regulation	$REG_{LOAD}$	$T_J=25^{\circ}C$ $5mA \leq I_{OUT} \leq 100mA$ $5mA \leq I_{OUT} \leq 40mA$	--	15 5	60 30	
Quiescent Current	$I_Q$	$I_{OUT}=0$ , $T_J=25^{\circ}C$	--	3	6	mA
Quiescent Current Change	$\Delta I_Q$	$5.8V \leq V_{IN} \leq 20V$	--	--	1.5	
		$5mA \leq I_{OUT} \leq 40mA$	--	--	0.1	
Output Noise Voltage	$V_N$	$10Hz \leq f \leq 100KHz$ , $T_J=25^{\circ}C$	--	40	--	$\mu V$
Ripple Rejection Ratio	RR	$f=120Hz$ , $5.8V \leq V_{IN} \leq 20V$	41	49	--	dB
Voltage Drop	$V_{DROP}$	$I_{OUT}=100mA$ , $T_J=25^{\circ}C$	--	2	--	V
Peak Output Current	$I_{o peak}$	$T_J=25^{\circ}C$	--	0.15	--	A
Temperature Coefficient of Output Voltage	$\Delta V_{OUT} / \Delta T_J$	$I_{OUT}=5mA$ , $0^{\circ}C \leq T_J \leq 150^{\circ}C$	--	-0.2	--	mV/ $^{\circ}C$

- Pulse testing techniques are used to maintain the junction temperature as close to the ambient temperature as possible, and thermal effects must be taken into account separately.
- This specification applies only for DC power dissipation permitted by absolute maximum ratings.

### TS78L05 Electrical Characteristics

( $V_{IN}=10V$ ,  $I_{OUT}=40mA$ ,  $0^{\circ}C \leq T_J \leq 125^{\circ}C$ ,  $C_{IN}=0.33\mu F$ ,  $C_{OUT}=0.1\mu F$ ; unless otherwise specified.)

Parameter	Symbol	Test Condition	Min	Typ	Max	Unit
Output voltage	$V_{OUT}$	$T_J=25^{\circ}C$	4.80	5	5.20	V
		$7.5V \leq V_{IN} \leq 20V$ , $5mA \leq I_{OUT} \leq 100mA$	4.75	5	5.25	
Line Regulation	$REG_{LINE}$	$T_J=25^{\circ}C$ $7.5V \leq V_{IN} \leq 20V$ $I_{OUT}=100mA$	--	50	150	mV
Load Regulation	$REG_{LOAD}$	$T_J=25^{\circ}C$ $5mA \leq I_{OUT} \leq 100mA$ $5mA \leq I_{OUT} \leq 40mA$	--	20 10	60 30	
Quiescent Current	$I_Q$	$I_{OUT}=0$ , $T_J=25^{\circ}C$	--	3	6	mA
Quiescent Current Change	$\Delta I_Q$	$7.5V \leq V_{IN} \leq 20V$	--	--	1.5	
		$5mA \leq I_{OUT} \leq 40mA$	--	--	0.1	
Output Noise Voltage	$V_N$	$10Hz \leq f \leq 100KHz$ , $T_J=25^{\circ}C$	--	40	--	$\mu V$
Ripple Rejection Ratio	RR	$f=120Hz$ , $7.5V \leq V_{IN} \leq 20V$	41	49	--	dB
Voltage Drop	$V_{DROP}$	$I_{OUT}=100mA$ , $T_J=25^{\circ}C$	--	1.7	--	V
Peak Output Current	$I_{o\ peak}$	$T_J=25^{\circ}C$	--	0.15	--	A
Temperature Coefficient of Output Voltage	$\Delta V_{OUT} / \Delta T_J$	$I_{OUT}=5mA$ , $0^{\circ}C \leq T_J \leq 150^{\circ}C$	--	-0.65	--	$mV/^{\circ}C$

### TS78L09 Electrical Characteristics

( $V_{IN}=15V$ ,  $I_{OUT}=40mA$ ,  $0^{\circ}C \leq T_J \leq 125^{\circ}C$ ,  $C_{IN}=0.33\mu F$ ,  $C_{OUT}=0.1\mu F$ ; unless otherwise specified.)

Parameter	Symbol	Test Condition	Min	Typ	Max	Unit
Output voltage	$V_{OUT}$	$T_J=25^{\circ}C$	8.65	9	9.36	V
		$11.5V \leq V_{IN} \leq 23V$ , $5mA \leq I_{OUT} \leq 100mA$	8.57	9	9.45	
Line Regulation	$REG_{LINE}$	$T_J=25^{\circ}C$ $11.5V \leq V_{IN} \leq 23V$ $I_{OUT}=40mA$	--	90	180	mV
Load Regulation	$REG_{LOAD}$	$T_J=25^{\circ}C$ $5mA \leq I_{OUT} \leq 100mA$ $5mA \leq I_{OUT} \leq 40mA$	--	30 15	90 45	
Quiescent Current	$I_Q$	$I_{OUT}=0$ , $T_J=25^{\circ}C$	--	3	6	mA
Quiescent Current Change	$\Delta I_Q$	$11.5V \leq V_{IN} \leq 23V$	--	--	1.5	
		$5mA \leq I_{OUT} \leq 40mA$	--	--	0.1	
Output Noise Voltage	$V_N$	$10Hz \leq f \leq 100KHz$ , $T_J=25^{\circ}C$	--	60	--	$\mu V$
Ripple Rejection Ratio	RR	$f=120Hz$ , $11.5V \leq V_{IN} \leq 23V$	37	57	--	dB
Voltage Drop	$V_{DROP}$	$I_{OUT}=100mA$ , $T_J=25^{\circ}C$	--	1.7	--	V
Peak Output Current	$I_{o\ peak}$	$T_J=25^{\circ}C$	--	0.15	--	A
Temperature Coefficient of Output Voltage	$\Delta V_{OUT} / \Delta T_J$	$I_{OUT}=5mA$ , $0^{\circ}C \leq T_J \leq 150^{\circ}C$	--	-0.9	--	$mV/^{\circ}C$

- Pulse testing techniques are used to maintain the junction temperature as close to the ambient temperature as possible, and thermal effects must be taken into account separately.
- This specification applies only for DC power dissipation permitted by absolute maximum ratings.

### TS78L12 Electrical Characteristics

( $V_{IN}=19V$ ,  $I_{OUT}=40mA$ ,  $0^{\circ}C \leq T_J \leq 125^{\circ}C$ ,  $C_{IN}=0.33\mu F$ ,  $C_{OUT}=0.1\mu F$ ; unless otherwise specified.)

Parameter	Symbol	Test Condition	Min	Typ	Max	Unit
Output voltage	$V_{OUT}$	$T_J=25^{\circ}C$	11.53	12	12.48	V
		$14.5V \leq V_{IN} \leq 27V$ , $5mA \leq I_{OUT} \leq 100mA$	11.42	12	12.60	
Line Regulation	$REG_{LINE}$	$T_J=25^{\circ}C$ $14.5V \leq V_{IN} \leq 27V$ $I_{OUT}=40mA$	--	120	240	mV
Load Regulation	$REG_{LOAD}$	$T_J=25^{\circ}C$ $5mA \leq I_{OUT} \leq 100mA$ $5mA \leq I_{OUT} \leq 40mA$	--	40 20	120 60	
Quiescent Current	$I_Q$	$I_{OUT}=0$ , $T_J=25^{\circ}C$	--	3	6.5	mA
Quiescent Current Change	$\Delta I_Q$	$14.5V \leq V_{IN} \leq 27V$ $5mA \leq I_{OUT} \leq 40mA$	--	--	1.5 0.1	
Output Noise Voltage	$V_N$	$10Hz \leq f \leq 100KHz$ , $T_J=25^{\circ}C$	--	80	--	$\mu V$
Ripple Rejection Ratio	RR	$f=120Hz$ , $14.5V \leq V_{IN} \leq 27V$	37	42	--	dB
Voltage Drop	$V_{DROP}$	$I_{OUT}=100mA$ , $T_J=25^{\circ}C$	--	1.7	--	V
Peak Output Current	$I_{o\ peak}$	$T_J=25^{\circ}C$	--	0.15	--	A
Temperature Coefficient of Output Voltage	$\Delta V_{OUT} / \Delta T_J$	$I_{OUT}=5mA$ , $0^{\circ}C \leq T_J \leq 150^{\circ}C$	--	-1.0	--	mV/ $^{\circ}C$

### TS78L15 Electrical Characteristics

( $V_{IN}=23V$ ,  $I_{OUT}=40mA$ ,  $0^{\circ}C \leq T_J \leq 125^{\circ}C$ ,  $C_{IN}=0.33\mu F$ ,  $C_{OUT}=0.1\mu F$ ; unless otherwise specified.)

Parameter	Symbol	Test Condition	Min	Typ	Max	Unit
Output voltage	$V_{OUT}$	$T_J=25^{\circ}C$	14.42	15	15.60	V
		$17.5V \leq V_{IN} \leq 30V$ , $5mA \leq I_{OUT} \leq 100mA$	14.28	15	15.75	
Line Regulation	$REG_{LINE}$	$T_J=25^{\circ}C$ $17.5V \leq V_{IN} \leq 30V$ $I_{OUT}=40mA$	--	150	300	mV
Load Regulation	$REG_{LOAD}$	$T_J=25^{\circ}C$ $5mA \leq I_{OUT} \leq 100mA$ $5mA \leq I_{OUT} \leq 40mA$	--	50 25	150 75	
Quiescent Current	$I_Q$	$I_{OUT}=0$ , $T_J=25^{\circ}C$	--	3	6.6	mA
Quiescent Current Change	$\Delta I_Q$	$17.5V \leq V_{IN} \leq 30V$ $5mA \leq I_{OUT} \leq 40mA$	--	--	1.5 0.1	
Output Noise Voltage	$V_N$	$10Hz \leq f \leq 100KHz$ , $T_J=25^{\circ}C$	--	90	--	$\mu V$
Ripple Rejection Ratio	RR	$f=120Hz$ , $17.5V \leq V_{IN} \leq 30V$	34	39	--	dB
Voltage Drop	$V_{DROP}$	$I_{OUT}=100mA$ , $T_J=25^{\circ}C$	--	1.7	--	V
Peak Output Current	$I_{o\ peak}$	$T_J=25^{\circ}C$	--	0.15	--	A
Temperature Coefficient of Output Voltage	$\Delta V_{OUT} / \Delta T_J$	$I_{OUT}=5mA$ , $0^{\circ}C \leq T_J \leq 150^{\circ}C$	--	-1.3	--	mV/ $^{\circ}C$

- Pulse testing techniques are used to maintain the junction temperature as close to the ambient temperature as possible, and thermal effects must be taken into account separately.
- This specification applies only for DC power dissipation permitted by absolute maximum ratings.

### TS78L24 Electrical Characteristics

( $V_{IN}=33V$ ,  $I_{OUT}=40mA$ ,  $0^{\circ}C \leq T_J \leq 125^{\circ}C$ ,  $C_{IN}=0.33\mu F$ ,  $C_{OUT}=0.1\mu F$ ; unless otherwise specified.)

Parameter	Symbol	Test Condition	Min	Typ	Max	Unit
Output voltage	$V_{OUT}$	$T_J=25^{\circ}C$	23.07	24	24.96	V
		$27V \leq V_{IN} \leq 38V$ , $5mA \leq I_{OUT} \leq 100mA$	22.85	24	25.20	
Line Regulation	$REG_{LINE}$	$T_J=25^{\circ}C$ $27 \leq V_{IN} \leq 38V$ $I_{OUT}=40mA$	--	200	400	mV
Load Regulation	$REG_{LOAD}$	$T_J=25^{\circ}C$ $5mA \leq I_{OUT} \leq 100mA$ $5mA \leq I_{OUT} \leq 40mA$	--	80 40	240 120	
Quiescent Current	$I_Q$	$I_{OUT}=0$ , $T_J=25^{\circ}C$	--	4	7	mA
Quiescent Current Change	$\Delta I_Q$	$27V \leq V_{IN} \leq 38V$	--	--	1.5	
		$5mA \leq I_{OUT} \leq 40mA$	--	--	0.1	
Output Noise Voltage	$V_N$	$10Hz \leq f \leq 100KHz$ , $T_J=25^{\circ}C$	--	200	--	$\mu V$
Ripple Rejection Ratio	RR	$f=120Hz$ , $27V \leq V_{IN} \leq 38V$	31	45	--	dB
Voltage Drop	$V_{DROP}$	$I_{OUT}=100mA$ , $T_J=25^{\circ}C$	--	1.7	--	V
Peak Output Current	$I_{o\ peak}$	$T_J=25^{\circ}C$	--	0.15	--	A
Temperature Coefficient of Output Voltage	$\Delta V_{OUT} / \Delta T_J$	$I_{OUT}=5mA$ , $0^{\circ}C \leq T_J \leq 150^{\circ}C$	--	-2.0	--	$mV/^{\circ}C$

- Pulse testing techniques are used to maintain the junction temperature as close to the ambient temperature as possible, and thermal effects must be taken into account separately.
- This specification applies only for DC power dissipation permitted by absolute maximum ratings.

### Application Information

#### Design Considerations

The TS78L00 Series of fixed voltage regulators are designed with Thermal Overload Protection that shuts down the circuit when subjected to an excessive power overload condition. Internal Short Circuit protection Limits the maximum current the circuit will pass.

In many low current applications, compensation capacitors are not required. However, it is recommended that the regulator input be bypassed with a capacitor if the regulator is connected to the power supply filter with long wire lengths, or if the output load capacitance is large. The input bypass capacitor should be selected to provide good high-frequency characteristics to insure stable operation under all load conditions. A 0.33µF or larger tantalum, mylar, or other capacitor having low internal impedance at high frequencies should be chosen. The bypass capacitor should be mounted with the shortest possible leads directly across the regulators input terminals. Good construction techniques should be used to minimize ground loops and lead resistance drops since the regulator has no external sense lead. Bypassing the output is also recommended.

**FIGURE 1 – Current Regulator**

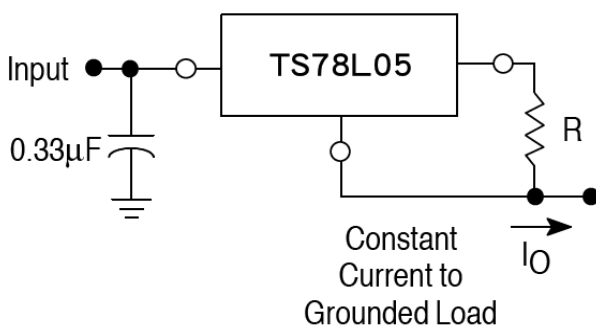

The TS78L00 regulators can also be used as a current source when connected as above. In order to minimize dissipation the TS78L05 is chosen in this application. Resistor R determines the current as follows:

$$I_O = \frac{5.0V}{R} + I_B$$

$I_B = 3.8mA$  over lined and load changes

For example, a 100mA current source would require R to be a 50Ω, 1/2W resistor and the output voltage compliance would be the input voltage less 7V.

**FIGURE 2 – ±15V Tracking Voltage Regulator**

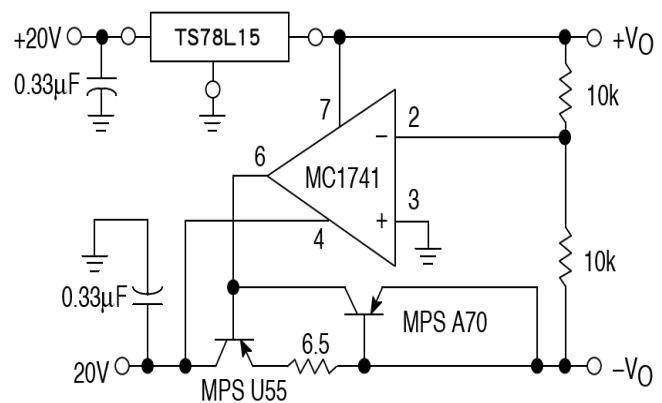

**FIGURE 3 – ±15V Tracking Voltage Regulator**

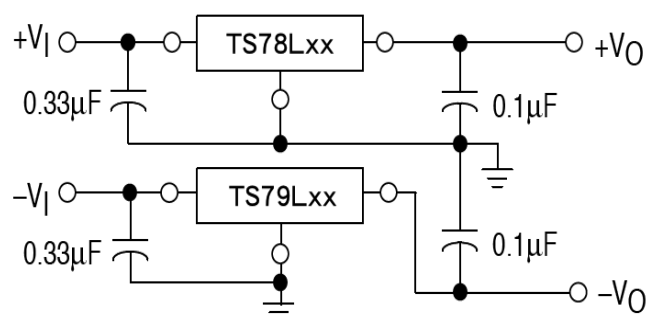

# TS78L00 Series

## 3-Terminal 100mA Positive Voltage Regulator

### Ordering information

Voltage	TO-92	SOT-89	SOP-8	SOT-23
3.3V	TS78L03CT B0 TS78L03CT A3	TS78L03ACY RM	TS78L03CS RL	TS78L03CX RF
5V	TS78L05CT B0 TS78L05CT A3	TS78L05ACY RM	TS78L05CS RL	TS78L05CX RF
9V	TS78L09CT B0 TS78L09CT A3	TS78L09ACY RM	TS78L09CS RL	TS78L09CX RF
12V	TS78L12CT B0 TS78L12CT A3	TS78L12ACY RM	TS78L12CS RL	
15V	TS78L15CT B0 TS78L15CT A3	TS78L15ACY RM	TS78L15CS RL	
24V			TS78L24CS RL	

### Packing code information

Packing	B0: 1kpcs / Bulk A3: 2kpcs / Ammo	1kpcs / 7" Reel	2.5kpcs / 13" Reel	3kpcs / 7"Reel

### TO-92 Mechanical Drawing

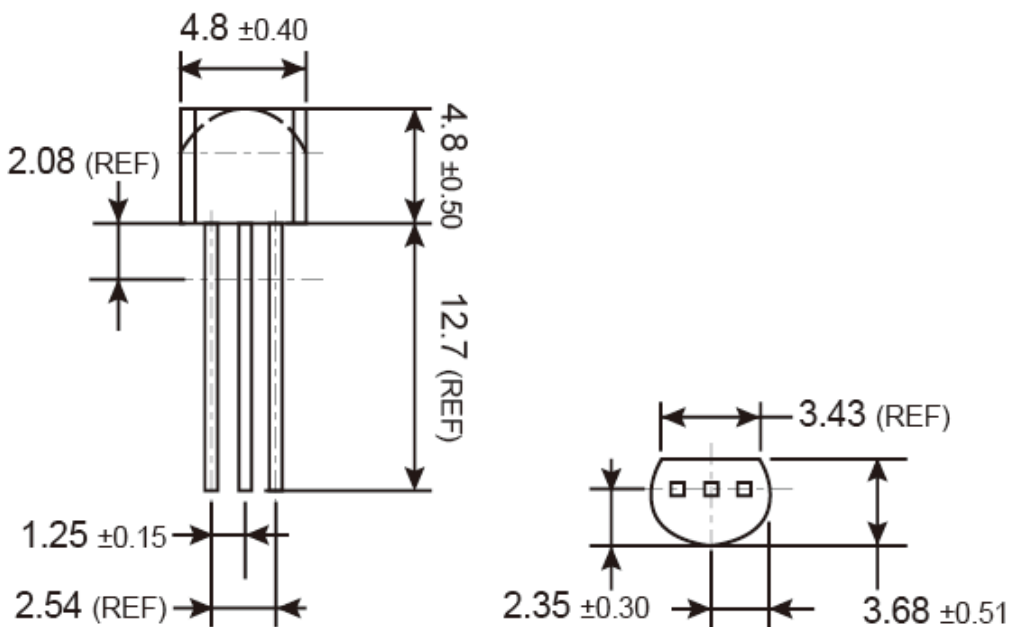

Unit: Millimeters

### Marking Diagram

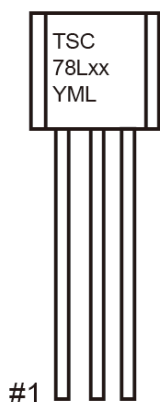

- XX** = Output Voltage  
(03=3.3V, 05=5V, 09=9V, 12=12V, 15=15V)
- Y** = Year Code
- M** = Month Code  
(**A**=Jan, **B**=Feb, **C**=Mar, **D**=Apr, **E**=May, **F**=Jun, **G**=Jul, **H**=Aug, **I**=Sep, **J**=Oct, **K**=Nov, **L**=Dec)
- L** = Lot Code



### SOT-89 Mechanical Drawing

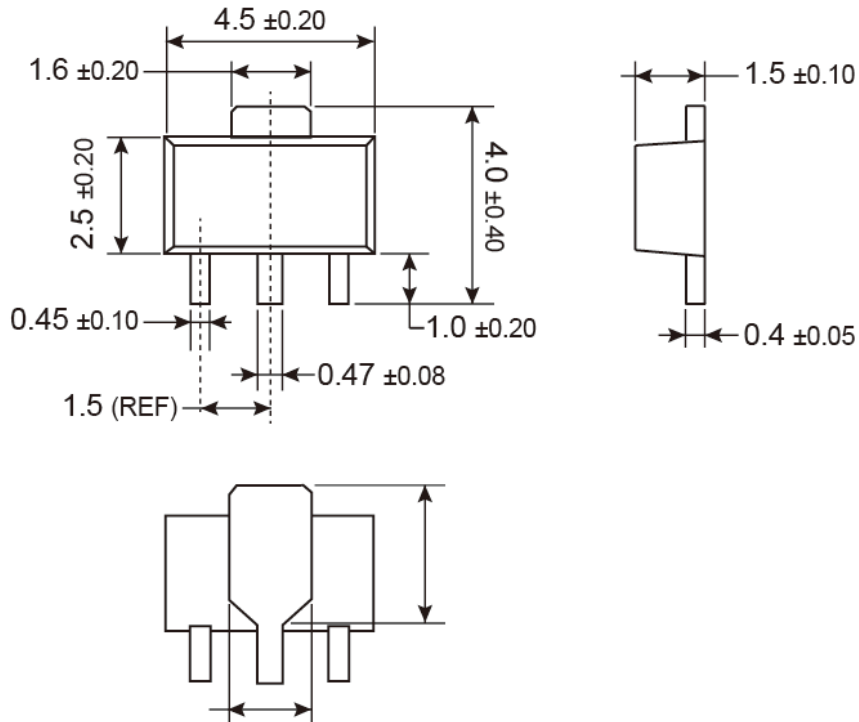

Unit: Millimeters

### Marking Diagram

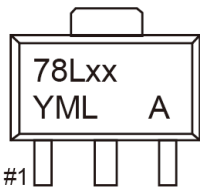

- XX** = Output Voltage  
(03=3.3V, 05=5V, 09=9V, 12=12V, 15=15V)
- Y** = Year Code
- M** = Month Code  
(**A**=Jan, **B**=Feb, **C**=Mar, **D**=Apr, **E**=May, **F**=Jun, **G**=Jul, **H**=Aug, **I**=Sep, **J**=Oct, **K**=Nov, **L**=Dec)
- L** = Lot Code
- A** = TS78LxxACY

### SOP-8 Mechanical Drawing

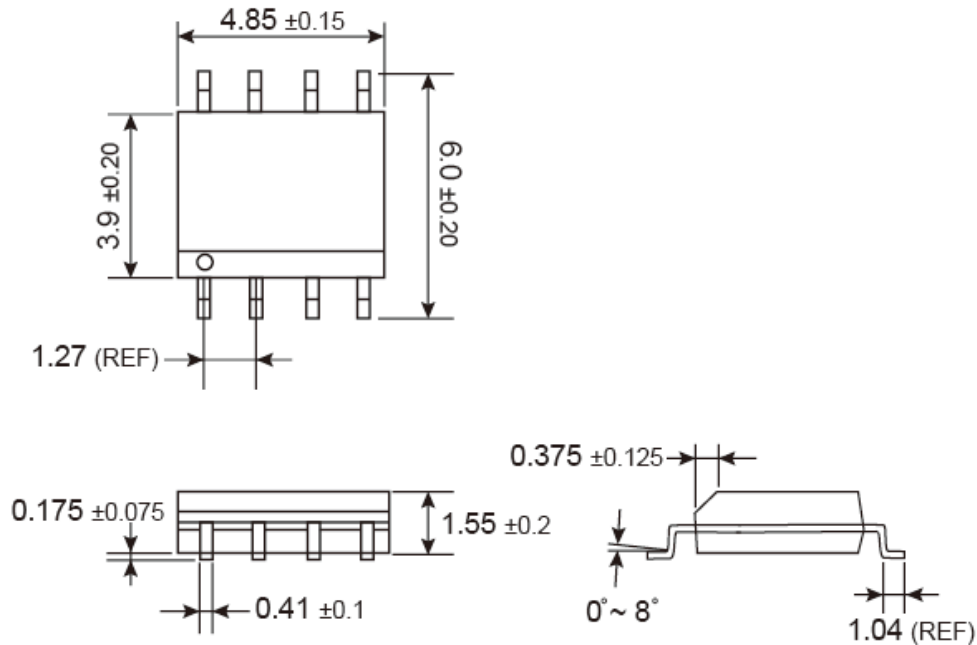

Unit: Millimeters

### Marking Diagram

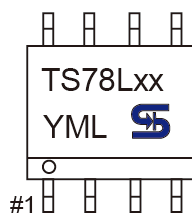

- XX** = Output Voltage  
(03=3.3V, 05=5V, 09=9V, 12=12V, 15=15V, 24=24V)
- Y** = Year Code
- M** = Month Code  
(A=Jan, B=Feb, C=Mar, D=Apr, E=May, F=Jun, G=Jul, H=Aug, I=Sep, J=Oct, K=Nov, L=Dec)
- L** = Lot Code

### SOT-23 Mechanical Drawing

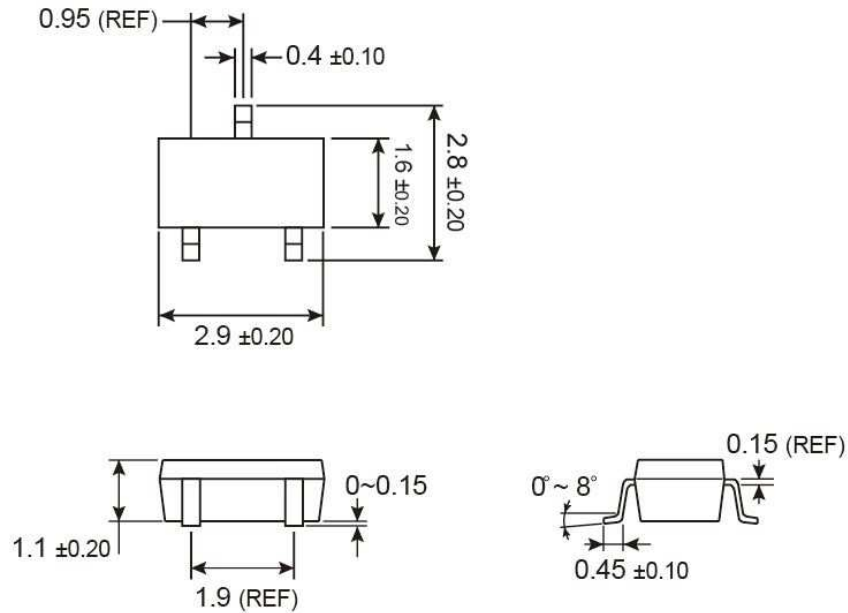

Unit: Millimeters

### Marking Diagram

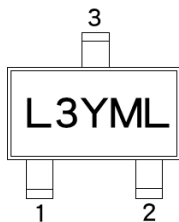

- L** = Device Voltage Code
- 3** (L3=3.3V, L5=5V, L9=9V)
- Y** = Year Code
- M** = Month Code  
(**A**=Jan, **B**=Feb, **C**=Mar, **D**=Apr, **E**=May, **F**=Jun, **G**=Jul, **H**=Aug, **I**=Sep, **J**=Oct, **K**=Nov, **L**=Dec)
- L** = Lot Code

### TO-92 Ammo Pack Mechanical Drawing

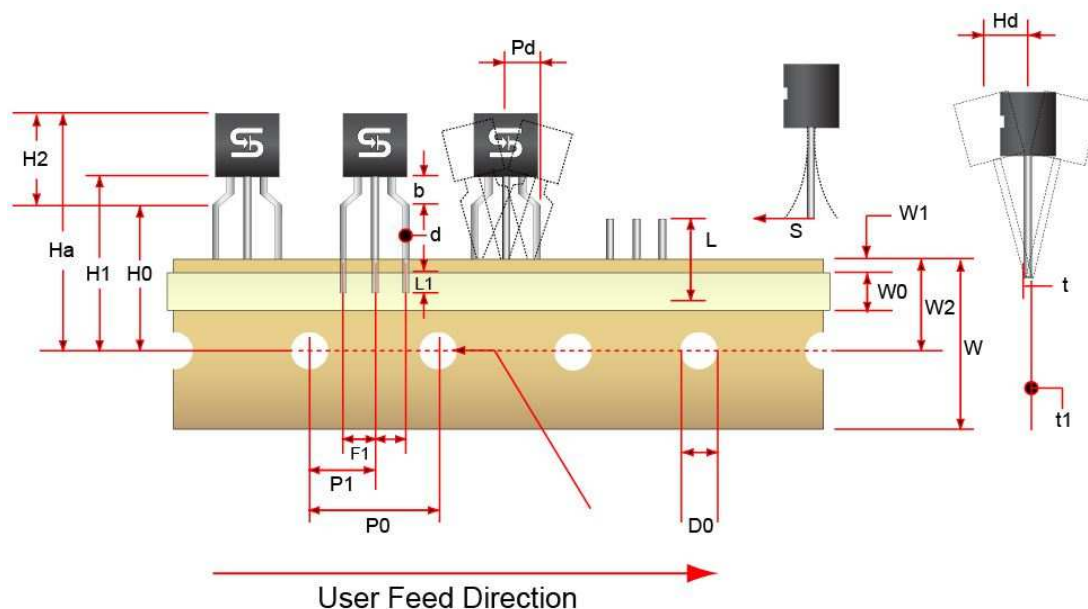

#### Tape Dimension

Item Description	Symbol	Dimension
Base of Package to Lead Bend	b	3.0 (typ.)
Component Height	Ha	23.57 (typ.)
Lead Clinch Height	H0	16.0 ±0.5
Component Base Height	H1	19.0 ±0.5
Component Top to Lead Bend	H2	8.0 (max)
Component Alignment (side / side)	Pd	1.02 (max)
Component Alignment (front / back)	Hd	0.79 (max)
Feed Hole Pitch	P0	12.7 ±0.3
Hole Center to Component Center	P1	6.25 ±0.4
Lead Spread	F1	2.5 ±0.3
Lead Thickness	d	0.46 (typ.)
Cut Lead Length	L	10.9 (max)
Taped Lead Length	L1	5.31 (typ.)
Taped Lead Thickness	t	0.81 ±0.2
Carrier Tape Thickness	t1	0.5 ±0.2
Carrier Tape Width	W	18.0 ±0.5
Hold – down Tape Width	W0	0.5 ±0.2
Hold – down Tape position	W1	9.0 ±0.7
Feed Hole Position	W2	6.0 ±0.2
Sprocket Hole Diameter	D0	4.0 ±0.2
Lead Spring Out	S	0.1 (max)

Note: All dimensions are in millimeter.

# TS78L00 Series

## 3-Terminal 100mA Positive Voltage Regulator

### Notice

Specifications of the products displayed herein are subject to change without notice. TSC or anyone on its behalf, assumes no responsibility or liability for any errors or inaccuracies.

Information contained herein is intended to provide a product description only. No license, express or implied, to any intellectual property rights is granted by this document. Except as provided in TSC's terms and conditions of sale for such products, TSC assumes no liability whatsoever, and disclaims any express or implied warranty, relating to sale and/or use of TSC products including liability or warranties relating to fitness for a particular purpose, merchantability, or infringement of any patent, copyright, or other intellectual property right.

The products shown herein are not designed for use in medical, life-saving, or life-sustaining applications. Customers using or selling these products for use in such applications do so at their own risk and agree to fully indemnify TSC for any damages resulting from such improper use or sale.

## X-ON Electronics

Largest Supplier of Electrical and Electronic Components

*Click to view similar products for [Linear Voltage Regulators](#) category:*

*Click to view products by [Taiwan Semiconductor](#) manufacturer:*

Other Similar products are found below :

[LV56831P-E](#) [LV5684PVD-XH](#) [MAX202ECWE-LF](#) [MCDTSA6-2R](#) [L4953G](#) [L7815ACV-DG](#) [PQ3DZ53U](#) [LV56801P-E](#)  
[TCR3DF13,LM\(CT](#) [TCR3DF39,LM\(CT](#) [TLE42794G](#) [L78L05CZ/1SX](#) [L78LR05DL-MA-E](#) [L78MR05-E](#) [033150D](#) [033151B](#) [090756R](#)  
[636416C](#) [NCV78M15BDTG](#) [702482B](#) [714954EB](#) [TLE42794GM](#) [TLE42994GM](#) [ZMR500QFTA](#) [BA033LBSG2-TR](#)  
[NCV78M05ABDTRKG](#) [NCV78M08BDTRKG](#) [NCP7808TG](#) [NCV571SN12T1G](#) [LV5680P-E](#) [CAJ24C256YI-GT3](#) [L78M15CV-DG](#) [L9474N](#)  
[TLS202B1MBV33HTSA1](#) [L79M05T-E](#) [NCP571SN09T1G](#) [MAX15006AASA/V+](#) [MIC5283-5.0YML-T5](#) [L4969URTR-E](#) [L78LR05D-MA-E](#)  
[NCV7808BDTRKG](#) [L9466N](#) [NCP7805ETG](#) [SC7812CTG](#) [NCV7809BTG](#) [NCV571SN09T1G](#) [NCV317MBTG](#) [MC78M15CDTT5G](#)  
[MC78M12CDTT5G](#) [L9468N](#)