

Quad relay board datasheet EB038-00-1

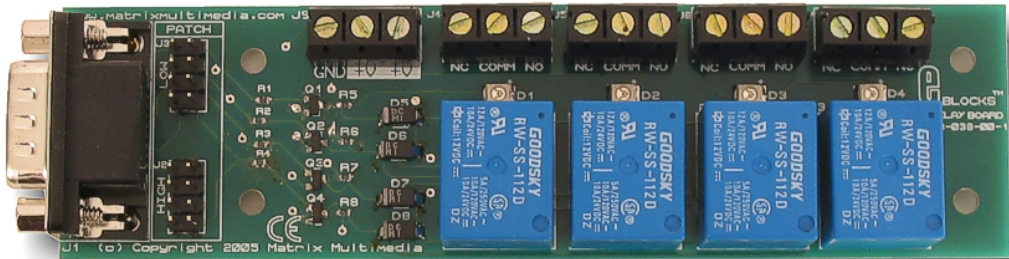

CONTENTS

- 1. About this document..... 2
- 2. General Information..... 3
- 3. Board layout..... 4
- 4. Testing this product..... 5
- 5. Circuit description..... 6

Appendix 1 Circuit diagram.

1. **About This Document**

This document concerns the Matrix Multimedia Quad Relay Board code EB038-00-1.

1. ***Trademarks and copyright***

PIC and PICmicro are registered trademarks of Arizona Microchip Inc.
E-blocks is a trademark of Matrix Multimedia Limited.
EB038 and associated software and documentation are Copyright ©2006 Matrix Multimedia Limited.

2. ***Other Sources of Information***

There are various other documents and sources that you may find useful:

Getting Started with E-Blocks.pdf

This describes the E-block system and how it can be used to develop complete systems for learning electronics and for PICmicro programming.

PPP Help File

This describes the PPP software and its functionality. PPP software is used for transferring hex code to a PICmicro microcontroller.

C and Assembly Strategies

For strategy information for creating 'C' and Assembly code for the Quad relay board see members area. This can be found at www.matrixmultimedia.com/eblocks

3. ***Disclaimer***

The information provided within this document was correct at the time of going to press. Matrix Multimedia reserves the right to change specifications from time to time.

4. ***Technical Support***

If you have any problems operating this product then please refer to the troubleshooting section of this document first. You will find the latest software updates, FAQs and other information on our web site: www.matrixmultimedia.co.uk. If you still have any problems please email us at: support@matrixmultimedia.co.uk. When emailing please state the operating system, the version of PPP you are using.

2. General information

As PICmicro microcontroller circuitry will not drive high power AC loads, some form of switch or ‘relay’ is required to perform the task. The EB038-00-1 Quad Relay Board was designed to switch four relays on and off as a direct response to the low voltage input of an EB006 Multiprogrammer Board. This in turn allows the user to switch multiple devices (ie, motors) simultaneously.

Relay rating

The EB038-00-1 Quad relay board creates an interface between an upstream e-block and apparatus operating at a higher voltage. Each of the PCB mounted relays is rated at 12V/6A and contains a 400Ω coil. Fig 1.0 illustrates a layout diagram of the relay.

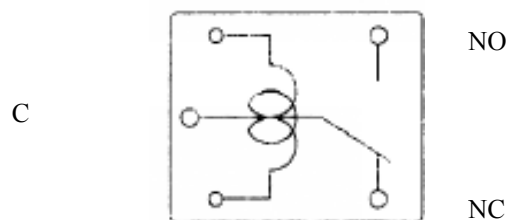

Fig 1.0. Bottom View.

C – Common.
 NO – Normally Open.
 NC – Normally Closed.

LEDs are employed within the circuit to register the switching status of the relay (ie, when relays switch to Normally Open, LEDs illuminate). VPWR must be greater than 12V.

A set of jumper links is available for the Quad relay board. Jumper links provide the user with the ability to control the relays with the HIGH nibble or LOW nibble.

NB. VPWR cannot be 3.3V or 5V. VPWR must be greater than 12V. VPWR can be supplied by +14V on the EB006 board.

1. **Features**

- Provides the capacity to operate two circuits at different voltage levels.
- Provides the ability to operate up to four devices (ie, motors) at varying speeds.
- Employs LEDs for instantaneous acknowledgment of relay setting.
- E-blocks compatible.

3. Quad relay board layout

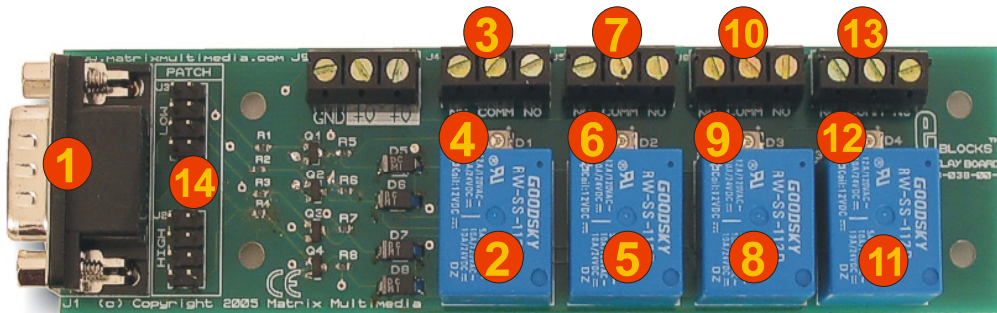

NB. Please ensure the mode selection jumpers are arranged on the board with the metal connection strips positioned horizontally.

- | | | | |
|----|------------------------------------|-----|--------------------|
| 1. | Downstream 9-way D type connector. | 10. | Output terminal 3. |
| 2. | Relay 1. | 11. | Relay 4. |
| 3. | Output terminal 1. | 12. | LED 4. |
| 4. | LED 1. | 13. | Output terminal 4. |
| 5. | Relay 2. | 14. | Patch system |
| 6. | LED 2. | 15. | Power terminal. |
| 7. | Output terminal 2. | | |
| 8. | Relay 3. | | |
| 9. | LED 3. | | |

Patch System

The patch system consists of two DIL connectors. Selecting the DIL connector labelled LOW permits the user to control the relays via bits 0 to 3. Selecting the DIL connector labelled HIGH allows the user to control the relays via bits 4 to 7. As stated previously please ensure mode selection jumpers are orientated correctly.

4. Testing This Product

The following instructions describe the test procedure for the EB038-00-1 Quad relay board.

1. System Setup

Multi-programmer board (EB-006) with:

| EB006 Options | Setting |
|-----------------|---------------------------|
| Power supply | External, 14V |
| PICmicro device | 16F877A |
| SW1 (Fast/Slow) | Don't care |
| SW2 (RC/Xtal) | Xtal |
| Xtal frequency | 19.6608MHz |
| Port A | |
| Port B | |
| Port C | Quad relay board EB038 |
| Port D | |
| Port E | |
| Test program | RELAYS_2.HEX |

| EB038 Options | Setting |
|----------------------|------------|
| Patch jumper setting | LOW nibble |

2. Test procedure

- Connect EB038-00-1 (Quad relay board) to PORTC of the multi-programmer and ensure jumper link is placed on the LOW nibble of the PATCH system. **NB.** Ensure jumper connector strips are positioned horizontally across the LOW nibble.
- Connect USB cable to computer.
- Ensure 13.5V power supply is working correctly.
- Connect a wire from the +14V screw terminal of the Multi-programmer to +V terminal of Quad Relay Board.
- Open PPP.
- Open file RELAYS_2.HEX.
- Click on “Configure PICmicro..” icon. In Select Chip section click on pull down menu and select the PIC16F877A. This will probably be the bottom choice. Ensure the chip is displayed in the Select Chip section.
- Click ‘OK’ to close the window and return to PPP.
- Once in PPP click on “Send To PICmicro” icon. A pop up window will inform you of status. If status is ok a “Program Sent And Verified” window will be observed on the screen
- LEDS D0 to D4 should illuminate in turn and the corresponding relays should be heard to switch (ie, click).
- Once D4 has illuminated change patch setting.

| EB038 Options | Setting |
|----------------------|-------------|
| Patch jumper setting | HIGH nibble |

- Again, LEDS D0 to D4 should illuminate in turn and the corresponding relays should be heard to switch (ie, click).

If all LEDs illuminate and corresponding relays switch on both LOW and HIGH nibble settings then the board has passed the test.

5. Circuit Description

The EB038 Quad relay circuit can be observed in Appendix1. From the circuit it can be seen that individual D type connector pins are employed to switch specific relays which in turn control external circuitry.

The EB-038 is powered from the +14V output on the EB006 Multiprogrammer. The Common; Normally Open and Normally Closed relay pins are attached to their corresponding output terminal and labelled accordingly. Although the relays are capable of switching mains voltage it is recommended that the user does not exceed **24V**.

3.3V Operation

This board is compatible with upstream boards operating off 3.3V.

Appendix 1 – Circuit diagram

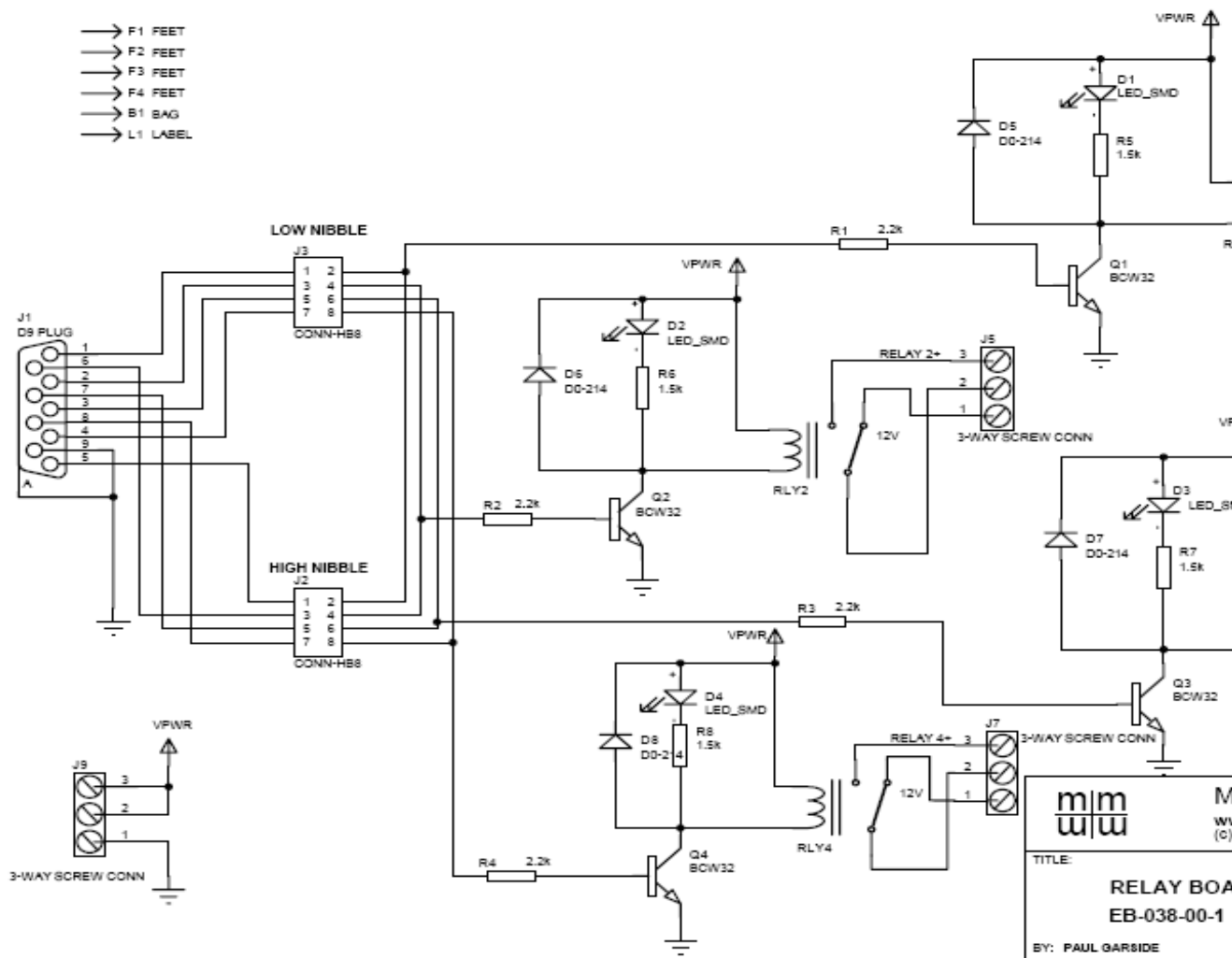

X-ON Electronics

Largest Supplier of Electrical and Electronic Components

Click to view similar products for [matrix orbital](#) manufacturer:

Other Similar products are found below :

[EB003](#) [LK202-25-USB-GW-E](#) [ESCCPC5V](#) [EGLK19264A-7T-WB-PL](#) [EGLK19264A-7T-USB-WB-PL](#) [BEZ-202C-V1-W-KIT](#) [BEZ-202C-V1-W-OEM](#) [EC927](#) [GLK19264A-7T-1U-USB-FGW](#) [LK162B-7T](#) [MOP-TFT800480-70A-BLM-TPC](#) [EVE2-38A-BLH-TPR](#) [EVE2-35A-BLM-TPR](#) [HTT70A-TPC-BLM-B0-H6-CH-VP](#) [GLK19264A-7T-1U-TCI-LV-E](#) [EGLK19264A-7T-WB-VPT-PL](#) [EVE3-43G-BLM-TPC-F32](#) [KPP204A-BK](#) [LK204-7T-1U-TCI](#) [B19264-BK](#) [LCD2041](#) [LCD2041-WB-E](#) [LK162A-4T-WB](#) [EVE2-43A-BLM-TPN](#) [GLK12232-25-SM-R14](#) [GLK12232-25-USB-FGW](#) [GTT50ATPRBLMB0H1CSV5](#) [LK202-25-GW](#) [VK204-25-USB](#) [MOP-TFT800480-50G-BLM-TPC](#) [EVE2-70G-BLM-TPC](#) [BLK202A-WB](#) [EVE2-70A-BLM-TPN](#) [EVE2-35A-BLM-TPN](#) [EVE3-70A-BLM-TPR-F32](#) [HTT70ATPNBLMB0H6CHV5](#) [OLED0821-OW](#) [VK204-25-E](#) [MOI-AV162A-NT3IJ](#) [VFD2041-VPT](#) [VK202-25-V](#) [GLK19264A-7T-1U-TCI](#) [GTT35ATPCBLMB0H1CSV5](#) [LK202-25](#) [GLK24064R-25-1U-WB](#) [EVE2-50G-BLM-TPC](#) [MOP-TFT800480-70A-BLM-TPN](#) [MOP-TFT480272-43A-BLM-TPN](#) [MOP-TFT480272-43A-BLM-TPC](#) [MOP-TFT480116-38A-BLH-TPR](#)