



2-phase Stepping Motor

86mm cir. 103H822 □
(3.39inch cir.) 1.8°/step

Recommendable Driver
 Refer to the page 7,17,27 and 45.

Specifications

Unipolar winding

Model		Holding torque at 2-phase energization N·m (oz·in) MIN.	Rated current A/phase	Resistance Ω/phase	Inductance mH/phase	Rotor inertia x10 ⁻⁴ kg·m ² (oz·in ²)	Mass(Weight) kg(lbs)
Single shaft	Double shaft						
103H8221-0441	-0411	2.15(304.5)	2	2.5	7.2	1.45(7.93)	1.5(3.31)
103H8221-0941	-0911	2.15(304.5)	4	0.62	1.8	1.45(7.93)	1.5(3.31)
103H8222-0441	-0411	4.13(584.8)	2	4.0	15	2.9(15.86)	2.5(5.51)
103H8222-0941	-0911	4.13(584.8)	4	0.97	3.6	2.9(15.86)	2.5(5.51)
103H8223-0441	-0411	6.27(887.9)	2	5.6	24	4.4(24.06)	3.5(7.72)
103H8223-0941	-0911	6.27(887.9)	4	1.35	5.6	4.4(24.06)	3.5(7.72)

Bipolar winding

Model		Holding torque at 2-phase energization N·m (oz·in) MIN.	Rated current A/phase	Resistance Ω/phase	Inductance mH/phase	Rotor inertia x10 ⁻⁴ kg·m ² (oz·in ²)	Mass(Weight) kg(lbs)
Single shaft	Double shaft						
103H8221-5041	-5011	2.74(388.0)	2	2.3	14	1.45(7.93)	1.5(3.31)
103H8221-5141	-5111	2.74(388.0)	4	0.6	3.5	1.45(7.93)	1.5(3.31)
103H8221-5241	-5211	2.74(388.0)	6	0.3	1.65	1.45(7.93)	1.5(3.31)
103H8222-5041	-5011	5.09(720.8)	2	2.7	23	2.9(15.86)	2.5(5.51)
103H8222-5141	-5111	5.09(720.8)	4	0.7	5.7	2.9(15.86)	2.5(5.51)
103H8222-5241	-5211	5.09(720.8)	6	0.35	2.7	2.9(15.86)	2.5(5.51)
103H8223-5041	-5011	7.44(1053.6)	2	3.6	32.5	4.4(24.06)	3.5(7.72)
103H8223-5141	-5111	7.44(1053.6)	4	0.9	8.1	4.4(24.06)	3.5(7.72)
103H8223-5241	-5211	7.44(1053.6)	6	0.45	3.4	4.4(24.06)	3.5(7.72)

Dimensions [Unit:mm(inch)]

103H8221-0441/0941 (Single shaft)
103H8221-0411/0911 (Double shaft)

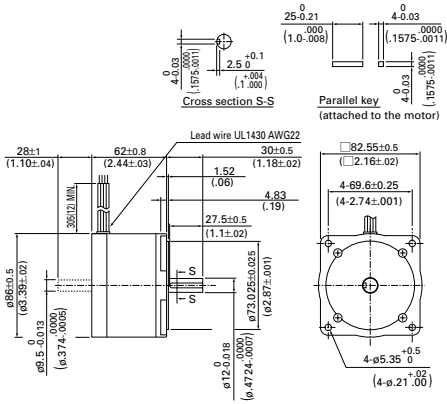

103H8222-0441/0941 (Single shaft)
103H8222-0411/0911 (Double shaft)

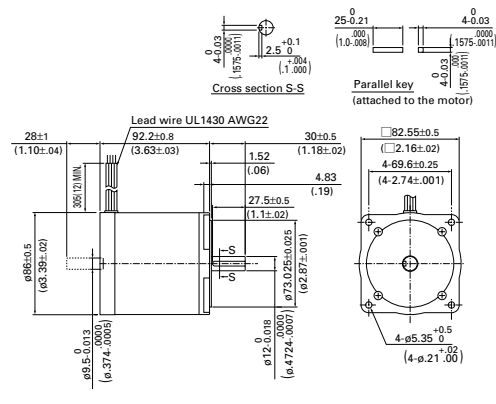

103H8223-0441/0941 (Single shaft)
103H8223-0411/0911 (Double shaft)

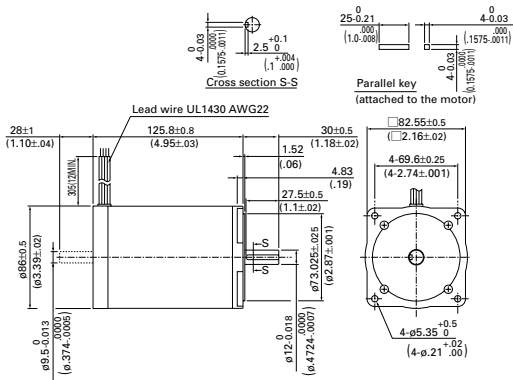

Bipolar winding

103H8221/103H8222/103H8223-5 □ 41 (Single shaft)
103H8221/103H8222/103H8223-5 □ 11 (Double shaft)

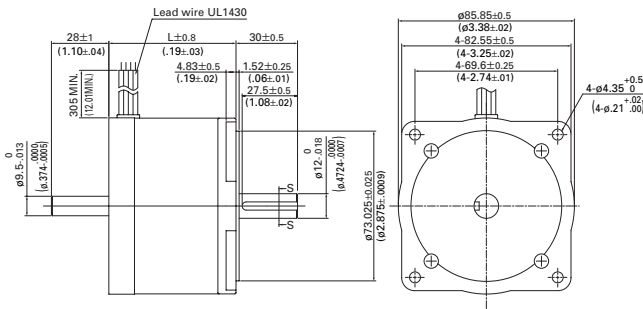

Model	AWG	L
103H8221-50 □ 1	22	62 (2.44)
103H8221-51 □ 1		
103H8221-52 □ 1		
103H8222-50 □ 1	18	92.2 (3.63)
103H8222-51 □ 1		
103H8222-52 □ 1	22	125.8 (4.95)
103H8223-50 □ 1		
103H8223-51 □ 1		
103H8223-52 □ 1	18	

φ35mm(1.38)/1.8"
 φ38mm(1.54)/0.9"
 φ42mm(1.65)/0.9"
 φ28mm(1.10)/1.8"
 φ28mm(1.10)/1.8"
 φ28mm(1.10)/1.8"
 φ50mm(1.97)/1.8"
 φ56mm(2.20)/1.8"
 φ60mm(2.36)/1.8"
 φ86mm(3.39)/1.8"
 φ106mm(4.17)/1.8"
 φ56mm(2.20)/CE
 φ86mm(3.39)/CE
 φ106mm(4.17)/CE

Specifications of 2-phase stepping motor
 In-vacuum stepping motor
 2-phase synchronous motor

Pulse Rate - Torque Characteristics

● 103H8221-0441

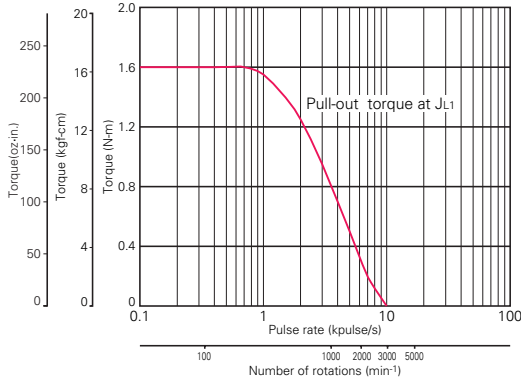

Sanyo constant current circuit
 Source voltage: AC100V Operating current: 2A/phase, 2-phase energization (full-step)
 $J_{L1}=[7.4 \times 10^{-4} \text{kg}\cdot\text{m}^2 (40.46 \text{ oz}\cdot\text{in}^2)]$ Use the rubber coupling]

● 103H8221-0941

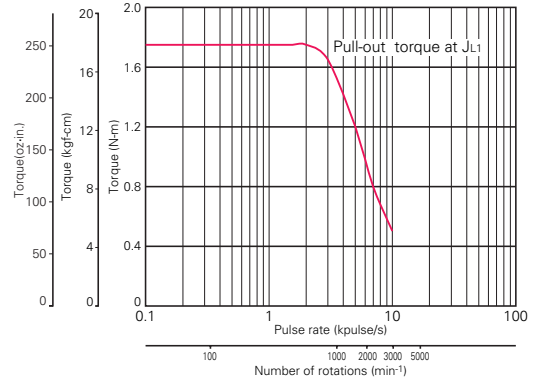

Sanyo constant current circuit
 Source voltage: AC100V Operating current: 4A/phase, 2-phase energization (full-step)
 $J_{L1}=[7.4 \times 10^{-4} \text{kg}\cdot\text{m}^2 (40.46 \text{ oz}\cdot\text{in}^2)]$ Use the rubber coupling]

● 103H8222-0441

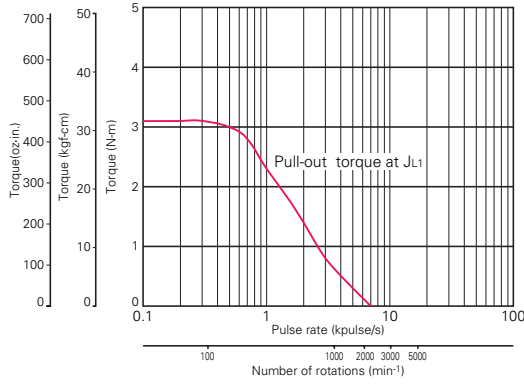

Sanyo constant current circuit
 Source voltage: AC100V Operating current: 2A/phase, 2-phase energization (full-step)
 $J_{L1}=[15.3 \times 10^{-4} \text{kg}\cdot\text{m}^2 (83.65 \text{ oz}\cdot\text{in}^2)]$ Use the rubber coupling]

● 103H8222-0941

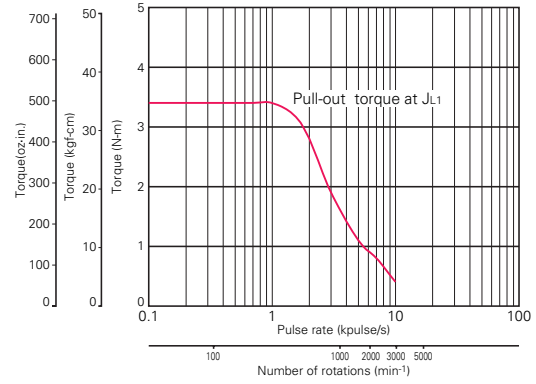

Sanyo constant current circuit
 Source voltage: AC100V Operating current: 4A/phase, 2-phase energization (full-step)
 $J_{L1}=[15.3 \times 10^{-4} \text{kg}\cdot\text{m}^2 (83.65 \text{ oz}\cdot\text{in}^2)]$ Use the rubber coupling]

● 103H8223-0441

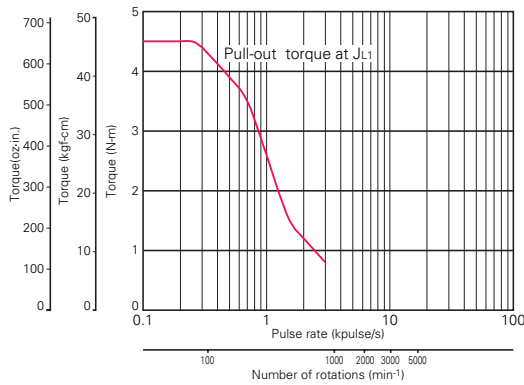

Sanyo constant current circuit
 Source voltage: AC100V Operating current: 2A/phase, 2-phase energization (full-step)
 $J_{L1}=[15.3 \times 10^{-4} \text{kg}\cdot\text{m}^2 (83.65 \text{ oz}\cdot\text{in}^2)]$ Use the rubber coupling]

● 103H8223-0941

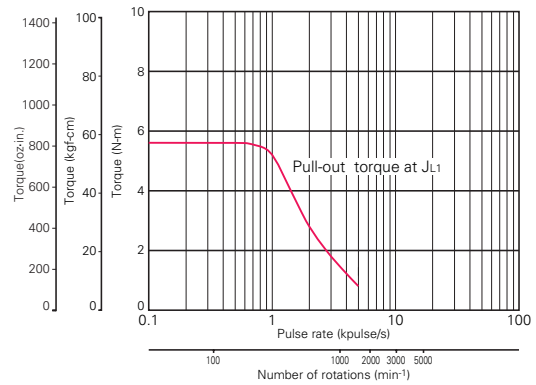

Sanyo constant current circuit
 Source voltage: AC100V Operating current: 4A/phase, 2-phase energization (full-step)
 $J_{L1}=[15.3 \times 10^{-4} \text{kg}\cdot\text{m}^2 (83.65 \text{ oz}\cdot\text{in}^2)]$ Use the rubber coupling]

Pulse Rate - Torque Characteristics

● 103H8221-5041

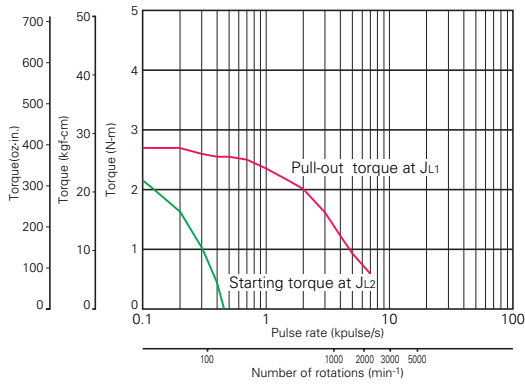

Sanyo constant current circuit
 Source voltage: AC100V Operating current: 2A/phase, 2-phase energization (full-step)
 $J_{L1}=[7.4 \times 10^{-4} \text{kg}\cdot\text{m}^2 (40.46 \text{ oz}\cdot\text{in}^2)]$ Use the rubber coupling)
 $J_{L2}=[7.4 \times 10^{-4} \text{kg}\cdot\text{m}^2 (40.46 \text{ oz}\cdot\text{in}^2)]$ Use the direct coupling)

● 103H8221-5141

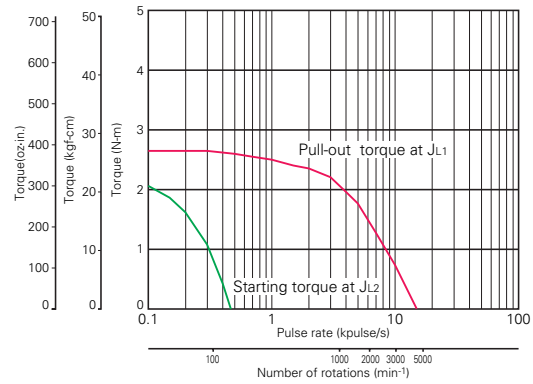

Sanyo constant current circuit
 Source voltage: AC100V Operating current: 4A/phase, 2-phase energization (full-step)
 $J_{L1}=[7.4 \times 10^{-4} \text{kg}\cdot\text{m}^2 (40.46 \text{ oz}\cdot\text{in}^2)]$ Use the rubber coupling)
 $J_{L2}=[7.4 \times 10^{-4} \text{kg}\cdot\text{m}^2 (40.46 \text{ oz}\cdot\text{in}^2)]$ Use the direct coupling)

● 103H8221-5241

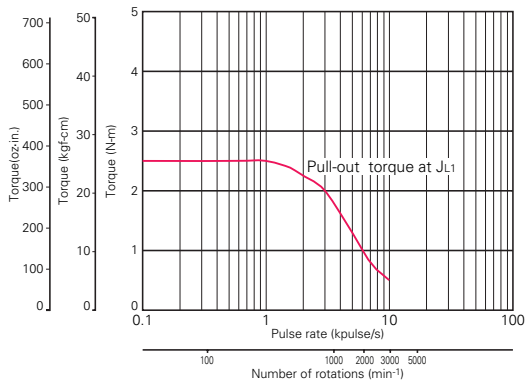

Sanyo constant current circuit
 Source voltage: AC100V Operating current: 6A/phase, 2-phase energization (full-step)
 $J_{L1}=[15.3 \times 10^{-4} \text{kg}\cdot\text{m}^2 (83.65 \text{ oz}\cdot\text{in}^2)]$ Use the rubber coupling)

● 103H8222-5041

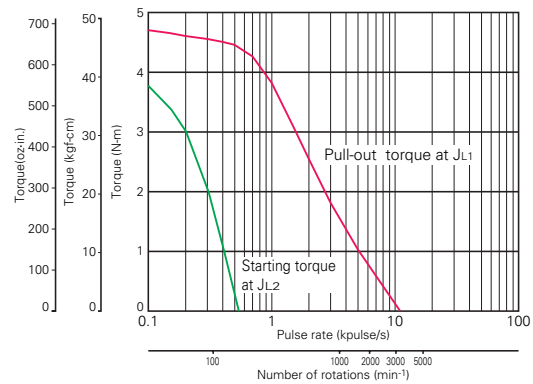

Sanyo constant current circuit
 Source voltage: AC100V Operating current: 2A/phase, 2-phase energization (full-step)
 $J_{L1}=[15.3 \times 10^{-4} \text{kg}\cdot\text{m}^2 (83.65 \text{ oz}\cdot\text{in}^2)]$ Use the rubber coupling)
 $J_{L2}=[15.3 \times 10^{-4} \text{kg}\cdot\text{m}^2 (83.65 \text{ oz}\cdot\text{in}^2)]$ Use the direct coupling)

● 103H8222-5141

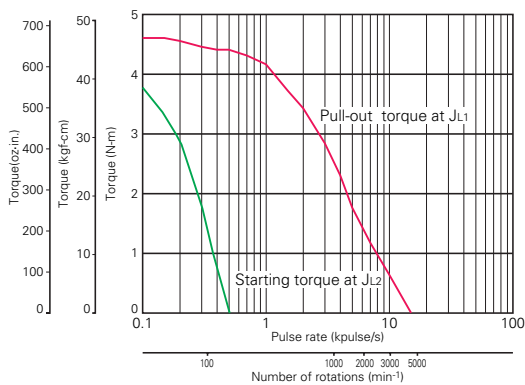

Sanyo constant current circuit
 Source voltage: AC100V Operating current: 4A/phase, 2-phase energization (full-step)
 $J_{L1}=[15.3 \times 10^{-4} \text{kg}\cdot\text{m}^2 (83.65 \text{ oz}\cdot\text{in}^2)]$ Use the rubber coupling)
 $J_{L2}=[15.3 \times 10^{-4} \text{kg}\cdot\text{m}^2 (83.65 \text{ oz}\cdot\text{in}^2)]$ Use the direct coupling)

● 103H8222-5241

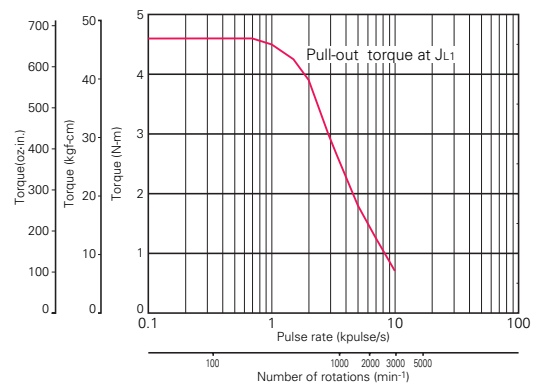

Sanyo constant current circuit
 Source voltage: AC100V Operating current: 6A/phase, 2-phase energization (full-step)
 $J_{L1}=[15.3 \times 10^{-4} \text{kg}\cdot\text{m}^2 (83.65 \text{ oz}\cdot\text{in}^2)]$ Use the rubber coupling)

Specifications of 2-phase synchronous motor
 In-vacuum stepping motor
 2-phase synchronous motor
 ø106mm(4.17)/CE ø86mm(3.39)/CE
 ø106mm(4.17)/1.8 ø86mm(3.39)/1.8
 ø60mm(2.36)/1.8 ø56mm(2.20)/1.8
 ø50mm(1.97)/1.8 ø42mm(1.65)/1.8
 ø38mm(1.54)/0.9 ø35mm(1.38)/1.8

Pulse Rate - Torque Characteristics

● 103H8223-5041

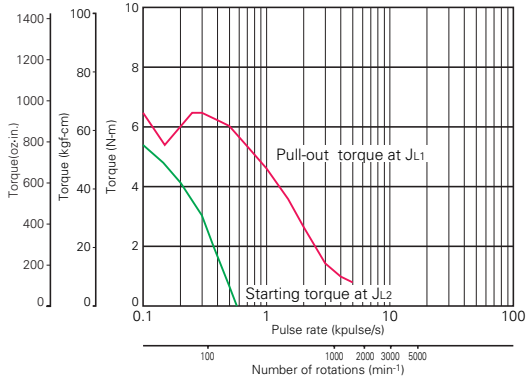

Sanyo constant current circuit

Source voltage: AC100V Operating current: 2A/phase, 2-phase energization (full-step)

$J_{L1}=[15.3 \times 10^{-4} \text{kg}\cdot\text{m}^2 (83.65 \text{oz}\cdot\text{in}^2)]$ Use the rubber coupling]

$J_{L2}=[15.3 \times 10^{-4} \text{kg}\cdot\text{m}^2 (83.65 \text{oz}\cdot\text{in}^2)]$ Use the direct coupling]

● 103H8223-5141

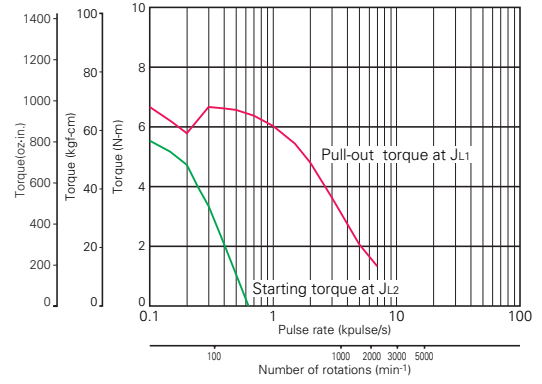

Sanyo constant current circuit

Source voltage: AC100V Operating current: 4A/phase, 2-phase energization (full-step)

$J_{L1}=[15.3 \times 10^{-4} \text{kg}\cdot\text{m}^2 (83.65 \text{oz}\cdot\text{in}^2)]$ Use the rubber coupling]

$J_{L2}=[15.3 \times 10^{-4} \text{kg}\cdot\text{m}^2 (83.65 \text{oz}\cdot\text{in}^2)]$ Use the direct coupling]

● 103H8223-5241

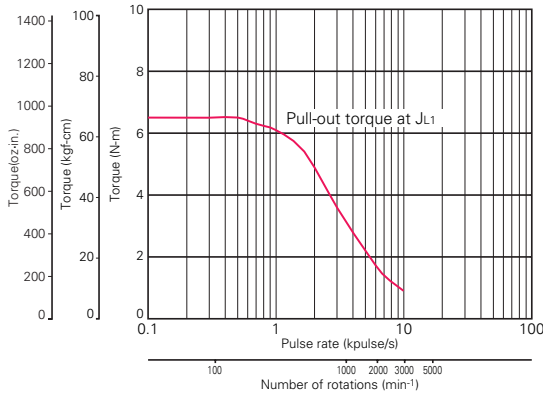

Sanyo constant current circuit

Source voltage: AC100V Operating current: 6A/phase, 2-phase energization (full-step)

$J_{L1}=[15.3 \times 10^{-4} \text{kg}\cdot\text{m}^2 (83.65 \text{oz}\cdot\text{in}^2)]$ Use the rubber coupling]

X-ON Electronics

Largest Supplier of Electrical and Electronic Components

Click to view similar products for [sanyo denki manufacturer](#):

Other Similar products are found below :

[9A0812G401](#) [9A0824H401](#) [9G0824H102](#) [9GA0812P1H61](#) [9GA0812P1S61](#) [9GL1212F101](#) [9GV1412P1G001](#) [9GV3612G301](#)
[9WG1212H102](#) [9WG1224G101](#) [SM2861-5255](#) [9GT0912P1M001](#) [9GV0312E302](#) [9S1212F4011](#) [9SG5748P5H01](#) [9WG1212E101](#) [489-007-](#)
[L21](#) [103H5208-5240](#) [103H7126-1740](#) [103H7822-5740](#) [109-1001F13](#) [109-1003M30](#) [109-313](#) [109L1748H501](#) [109L5712H501](#)
[109P1412M101](#) [109R0824S4D01](#) [109-1069](#) [109BF24HD2](#) [9L0412H301](#) [9GA0812P1S61P](#) [9G1212P4G03](#) [9G0612P1G03](#)
[9CRB0812P8G001](#) [103H8221-5141](#) [103H8223-6340](#) [9LG1248P1H001](#) [SH1603-5240](#) [9GA0812P1H611](#) [9BD12SC6-1](#) [109P0824H701](#) [109-](#)
[049C](#) [103H7123-5740](#) [9AH0912P4H03](#) [9G1224G1D01](#) [9GV1212P4G011](#) [9G1224M4D011](#) [9GV0824P1G03](#) [109P0624W602](#)
[9WF0924S201](#)