

ABJ1,2,3,4,5

<h1>NAIS</h1>	HIGH ENVIRONMENTAL RESISTANCE	<h1>TURQUOISE SWITCHES J TYPE (ABJ)</h1>
---------------	--------------------------------------	--

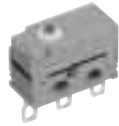

Dust protected type



(Mounting hole 2.3mm .091inch type)



Immersion protected type (wire leads bottom type)



(Mounting hole 2.3mm .091inch type)

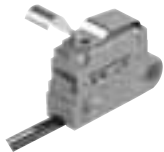

Immersion protected (wire leads side type)



Long stroke type

FEATURES

- **Ultra-miniature size (12.8×6.5×6 mm) (.504×.256×.236 inch)**
- **Sealed construction for use in adverse environment-Sealed construction by epoxy resin and rubber cap keeps off the cause of miscontact such as dust. Conforming to IP67* of IEC protective construction classification**
- **Elastomer double molding technology, an industry first and ultrasonic swaging technology contribute to uniform sealing in high production quantities**
- **UL/CSA approved**
- **Long stroke type is available**
Since the repeatability is excellent and the play distance (overtravel) from the operating position is ample, the task of performing the adjustments during installation is an easy one.
- **Operating position accuracy ±0.4 mm ±.016 inch**
- **Overtravel= Min. 2.0 mm .079 inch**
As wide range of high pressure is achieved, a stable reliability is ensured

TYPICAL APPLICATIONS

- **Industrial use video jack**
 - **Automotives (ex. Device for opening and shutting of automobile doors)**
- *Based on the protective construction classification of IEC, items which satisfy the test requirements are denoted with an IP designation.

ORDERING INFORMATION

Ex. **ABJ 1 4 1 0 4 0**

Type of switch	Size of mounting hole	Terminal	Contact arrangement	Actuator	Operating force by pin plunger (max.)	Contact
ABJ: Turquoise switch J type	1: 1.2 mm (.047 inch) 2: 2.3 mm (.091 inch) 3: 3 mm (.118 inch) 4: Screw mounting	4: Solder terminal 5: PC board terminal 6: Wire leads (bottom type) 7: Wire leads (right side type) 8: Wire leads (left side type)	1: SPDT 2: SPST-NC 3: SPST-NO	0: Pin plunger 2: Hinge lever 4: Simulated roller lever 6: Roller lever 8: Leaf lever L: Long stroke type	4: 125 gf 4.409 oz 6: 200 gf 7.055 oz 7: 250 gf (Long stroke type only)	0: Silver-alloy 1: Gold-clad

- Remarks: 1. Standard packing: Dust protected type 100 pcs./carton, 2,000 pcs./case; Immersion protected type 50 pcs./case.
 2. SPST-NC and SPST-NO are only available for wire leads type.
 3. Leaf lever is only available for wire leads type
 4. Not every combination is available. Please refer to the following table, "PRODUCT TYPES".

ABJ1,2,3,4,5

PRODUCT TYPES**1. Dust protected type (Terminal type)**

Mounting hole 1.2mm .047inch type / Mounting hole 2.3mm .091inch type

Silver alloy

Actuator	Operating force Max. gf oz	Mounting hole 1.2 mm .047 inch type		Mounting hole 2.3 mm .091 inch type
		Solder terminal	PC board terminal	Solder terminal
Pin plunger	125 4.409	ABJ141040	ABJ151040	ABJ241040
	200 7.055	ABJ141060	ABJ151060	ABJ241060
Hinge lever	40 1.411	ABJ141240	ABJ151240	ABJ241240
	65 2.293	ABJ141260	ABJ151260	ABJ241260
Simulated roller lever	40 1.411	ABJ141440	ABJ151440	ABJ241440
	65 2.293	ABJ141460	ABJ151460	ABJ241460
Roller lever	40 1.411	ABJ141640	ABJ151640	ABJ241640
	65 2.293	ABJ141660	ABJ151660	ABJ241660

Gold-clad

Actuator	Operating force Max. gf oz	Mounting hole 1.2 mm .047 inch type		Mounting hole 2.3 mm .091 inch type
		Solder terminal	PC board terminal	Solder terminal
Pin plunger	125 4.409	ABJ141041	ABJ151041	ABJ241041
	200 7.055	ABJ141061	ABJ151061	ABJ241061
Hinge lever	40 1.411	ABJ141241	ABJ151241	ABJ241241
	65 2.293	ABJ141261	ABJ151261	ABJ241261
Simulated roller lever	40 1.411	ABJ141441	ABJ151441	ABJ241441
	65 2.293	ABJ141461	ABJ151461	ABJ241461
Roller lever	40 1.411	ABJ141641	ABJ151641	ABJ241641
	65 2.293	ABJ141661	ABJ151661	ABJ241661

2-(1). Immersion protected type (Bottom wire leads type)

Mounting hole 1.2mm .047inch type

Silver alloy

Actuator	Operating force Max. gf oz	Mounting hole 1.2 mm .047 inch type		
		SPDT	SPST-NC	SPST-NO
Pin plunger	125 4.409	ABJ161040	ABJ162040	ABJ163040
	200 7.055	ABJ161060	ABJ162060	ABJ163060
Hinge lever	40 1.411	ABJ161240	ABJ162240	ABJ163240
	65 2.293	ABJ161260	ABJ162260	ABJ163260
Simulated roller lever	40 1.411	ABJ161440	ABJ162440	ABJ163440
	65 2.293	ABJ161460	ABJ162460	ABJ163460
Roller lever	40 1.411	ABJ161640	ABJ162640	ABJ163640
	65 2.293	ABJ161660	ABJ162660	ABJ163660

Mounting hole 2.3mm .091inch type

Gold-clad

Actuator	Operating force Max. gf oz	Mounting hole 1.2 mm .047 inch type		
		SPDT	SPST-NC	SPST-NO
Pin plunger	125 4.409	ABJ161041	ABJ162041	ABJ163041
	200 7.055	ABJ161061	ABJ162061	ABJ163061
Hinge lever	40 1.411	ABJ161241	ABJ162241	ABJ163241
	65 2.293	ABJ161261	ABJ162261	ABJ163261
Simulated roller lever	40 1.411	ABJ161441	ABJ162441	ABJ163441
	65 2.293	ABJ161461	ABJ162461	ABJ163461
Roller lever	40 1.411	ABJ161641	ABJ162641	ABJ163641
	65 2.293	ABJ161661	ABJ162661	ABJ163661

Remarks: When ordering UL/CSA approved types, please attach suffix "9" to the part number.

ABJ1,2,3,4,5

Mounting hole 2.3mm .091inch type

Silver alloy

Actuator	Operating force Max. gf oz	Mounting hole 2.3 mm .091 inch type		
		SPDT	SPST-NC	SPST-NO
Pin plunger	125 4.409	ABJ261040	ABJ262040	ABJ263040
	200 7.055	ABJ261060	ABJ262060	ABJ263060
Hinge lever	40 1.411	ABJ261240	ABJ262240	ABJ263240
	65 2.293	ABJ261260	ABJ262260	ABJ263260
Simulated roller lever	40 1.411	ABJ261440	ABJ262440	ABJ263440
	65 2.293	ABJ261460	ABJ262460	ABJ263460
Roller lever	40 1.411	ABJ261640	ABJ262640	ABJ263640
	65 2.293	ABJ261660	ABJ262660	ABJ263660

Gold-clad

Actuator	Operating force Max. gf oz	Mounting hole 2.3 mm .091 inch type		
		SPDT	SPST-NC	SPST-NO
Pin plunger	125 4.409	ABJ261041	ABJ262041	ABJ263041
	200 7.055	ABJ261061	ABJ262061	ABJ263061
Hinge lever	40 1.411	ABJ261241	ABJ262241	ABJ263241
	65 2.293	ABJ261261	ABJ262261	ABJ263261
Simulated roller lever	40 1.411	ABJ261441	ABJ262241	ABJ263441
	65 2.293	ABJ261461	ABJ262461	ABJ263461
Roller lever	40 1.411	ABJ261641	ABJ262641	ABJ263641
	65 2.293	ABJ261661	ABJ262661	ABJ263661

Mounting hole 3mm .118inch type (Leaf lever type)

Silver alloy

Actuator	Operating force Max. gf oz	Mounting hole 3 mm type		
		SPDT	SPST-NC	SPST-NO
Leaf lever	100 3.527	ABJ361840	ABJ362840	ABJ363840
	130 4.585	ABJ361860	ABJ362860	ABJ363860

Gold-clad

Actuator	Operating force Max. gf oz	Mounting hole 3 mm type		
		SPDT	SPST-NC	SPST-NO
Leaf lever	100 3.527	ABJ361841	ABJ362841	ABJ363841
	130 4.585	ABJ361861	ABJ362861	ABJ363861

2-(2). Immersion protected type (Side wire leads type)

Fixed pin (right side pin) type

Silver alloy

Actuator	Operating force Max. gf oz	Wire leads direction	Wire leads type	
			SPST-NC	SPST-NO
Leaf lever	130 4.586	Right	ABJ472840	ABJ473840
	130 4.586	Left	ABJ482840	—
	180 6.349	Right	ABJ472860	ABJ473860
	180 6.349	Left	ABJ482860	—

Gold-clad

Actuator	Operating force Max. gf oz	Wire leads direction	Wire leads type	
			SPST-NC	SPST-NO
Leaf lever	130 4.586	Right	ABJ472841	ABJ473841
	130 4.586	Left	ABJ482841	—
	180 6.349	Right	ABJ472861	ABJ473861
	180 6.349	Left	ABJ482861	—

Fixed pin (left side pin) type

Silver alloy

Actuator	Operating force Max. gf oz	Wire leads direction	Wire leads type	
			SPST-NC	SPST-NO
Leaf lever	130 4.586	Right	ABJ572840	ABJ573840
	130 4.586	Left	ABJ582840	—
	180 6.349	Right	ABJ572860	ABJ573860
	180 6.349	Left	ABJ582860	—

Remarks: When ordering UL/CSA approved types, please attach suffix "9" to the part number.

ABJ1,2,3,4,5

Gold-clad

Actuator	Operating force Max. gf oz	Wire leads direction	Wire leads type	
			SPST-NC	SPST-NO
Leaf lever	130 4.586	Right	ABJ572841	ABJ573841
	130 4.586	Left	ABJ582841	—
	180 6.349	Right	ABJ572861	ABJ573861
	180 6.349	Left	ABJ582861	—

Mounting hole 3mm .118inch type

Silver alloy

Actuator	Operating force Max. gf oz	Wire leads direction	Wire leads type	
			SPST-NC	SPST-NO
Leaf lever	130 4.586	Left	ABJ382840	—
	180 6.349		ABJ382860	—

Gold-clad

Actuator	Operating force Max. gf oz	Wire leads direction	Wire leads type	
			SPST-NC	SPST-NO
Leaf lever	130 4.586	Left	ABJ382841	—
	180 6.349		ABJ382861	—

3. Immersion protected type (Bottom wire leads type) Long stroke type

Mounting hole 2.3mm type

Silver alloy

Actuator	Operating force Max. gf oz	Mounting hole 2.3 mm type		
		SPDT	SPST-NC	SPST-NO
Pin plunger (Horizontal)	250 8.818	ABJ261L70	ABJ262L70	ABJ263L70

Gold-clad

Actuator	Operating force Max. gf oz	Mounting hole 2.3 mm type		
		SPDT	SPST-NC	SPST-NO
Pin plunger (Horizontal)	250 8.818	ABJ261L71	ABJ262L71	ABJ263L71

Remarks: When ordering UL/CSA approved types, please attach suffix "9" to the part number.

APPLICABLE CURRENT RANGE

Contact	Applicable current range				Max. Operating force for operation (at pin plunger)	
	1mA	0.1A	1A	2A	125gf	200gf
Ag			●		●	
				●		●
Au	●				●	
	●					●

SPECIFICATIONS**1. Contact rating**

	Type	Standard rating	Low-level circuit rating
Silver alloy contact	O.F. 200 gf 7.055 oz Max.	2 A 125 V AC 2 A 30 V DC	—
	O.F. 125 gf 4.409 oz Max.	1 A 125 V AC 1 A 30 V DC	—
Long stroke type Silver alloy contact	O.F. 250 gf 8.818 oz Max.	1 A 125 V AC 1 A 30 V DC	—
Gold-clad contact	O.F. 200 gf 7.055 oz Max. O.F. 125 gf 4.409 oz Max.	0.1 A 125 V AC	5 mA 6 V DC 2 mA 12 V DC 1 mA 24 V DC
Long stroke type Gold-clad contact	O.F. 250 gf 8.818 oz Max.	0.1 A 125 V AC 0.1 A 30 V DC	5 mA 6 V DC 2 mA 12 V DC 1 mA 24 V DC

ABJ1,2,3,4,5

2. Characteristics

Mechanical life (O.T.: Specified value)	Leaf lever, Long stroke type	Min. 5×10^5 (at 60 cpm)
Mechanical life (O.T.: Specified value)	Other types	Min. 10^6 (at 60 cpm)
Electrical life at rated load (O.T.: max.)	Silver alloy contact type	Min. 3×10^4 (at 60 cpm)
	Gold-clad contact type	Min. 10^5 (at 20 cpm)
Insulation resistance		Min. 100 M Ω (at 500 V DC)
Dielectric strength		600 Vrms 1,500 Vrms 1,500 Vrms
	Between non-continuous terminals	600 Vrms
	Between each terminal and other exposed metal parts	1,500 Vrms
	Between each terminal and ground	1,500 Vrms
Vibration resistance (Pin plunger type)		10 to 55 Hz at single amplitude of 0.75 mm (Contact opening max. 1 msec.)
Shock resistance (Pin plunger type)		Min. 294 m/s ² {30 G} (Contact opening max. 1 msec.)
Contact resistance (Initial)	Silver contact type	Dust protected type (IP50): Max. 50 m Ω Immersion protected type (IP67): Max. 100 m Ω (By voltage drop 1 A 6 to 8 V DC)
Contact resistance (Initial)	Gold clad contact type	Dust protected type (IP50): Max. 100 m Ω Immersion protected type (IP67): Max. 150 m Ω (By voltage drop 0.1 A 6 to 8 V DC)
Allowable operating speed (at no load)		1 to 500 mm/sec.
Max. operating cycle rate (at no load)		Other type: 120 cpm Long stroke type: 60 cpm
Ambient temperature		-40°C to +85°C -40°F to +185°F
Ambient humidity		Max. 95% R.H.
Unit weight		Approx. 0.5 g .018 oz (IP50 type)

3. Operating characteristics

Operating force / Release force / Pretravel

Type of actuator	Operating force, Max.		Release force, Min		Pretravel, Max. mm inch
Pin plunger	1.23N {125gf}	1.96N {200gf}	0.15N {15gf}	0.25N {25gf}	0.6 .024
Hinge lever	0.39N {40gf}	0.64N {65gf}	0.029N {3.0gf}	0.049N {5.0gf}	3.0 .118
Simulated roller lever	0.39N {40gf}	0.64N {65gf}	0.029N {3.0gf}	0.049N {5.0gf}	3.0 .118
Roller lever	0.39N {40gf}	0.64N {65gf}	0.029N {3.0gf}	0.049N {5.0gf}	3.0 .118
Leaf lever	0.98N {100gf}	1.27N {130gf}	0.20N {20gf}	0.29N {30gf}	6.0 .236
Long stroke type	2.45N {250gf}		0.19N {20gf}		—

Movement differential / Overtravel / Operating position

Type of actuator	Movement differential, Max. mm inch	Overtravel, Min. mm inch	Operating position, mm inch		
			Mounting hole: 1.2 .047	Mounting hole: 2.3 .091	Mounting hole: 3.0 .118
Pin plunger	0.12 .005	0.25 .010	5.5±0.2 .217 ± .008	7.0±0.2 .276 ± .008	—
Hinge lever	0.5 .020	0.5 .020	6.8±1.0 .286 ± .039	8.3±1.0 .327 ± .039	—
Simulated roller lever	0.5 .020	0.5 .020	9.8±1.0 .386 ± .039	11.3±1.0 .445 ± .039	—
Roller lever	0.5 .020	0.5 .020	13.1 ±1.0 .516 ± .039	14.6±1.0 .575 ± .039	—
Leaf lever	1.0 .039	2.5 .098	—	—	16.0±2.0 .630 ± .079
Long stroke type	0.5 .020	2.0 .079	—	2.5±0.4 .098 ± .016	—

() : Low force type

DIMENSIONS

mm inch General tolerance: ±0.25 ±.010

1. Dust protected type

1-(1) PC board terminal
Pin plunger

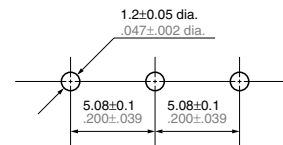
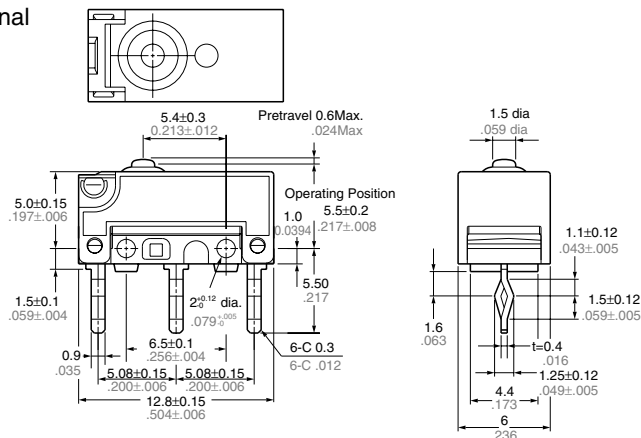

Pretravel, Max. mm inch	0.6 .024	
Movement differential, Max. mm inch	0.12 .005	
Overtravel, Min. mm inch	0.25 .010	
Operating position	Distance from mounting hole, mm inch	5.5±0.2 .217 ± .088
	Distance from stand-off, mm inch	7±0.3 .276 ± .012

ABJ1,2,3,4,5

Hinge lever

mm inch General tolerance: $\pm 0.25 \pm 0.10$

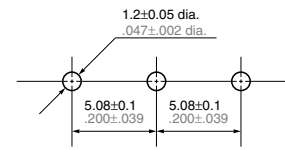
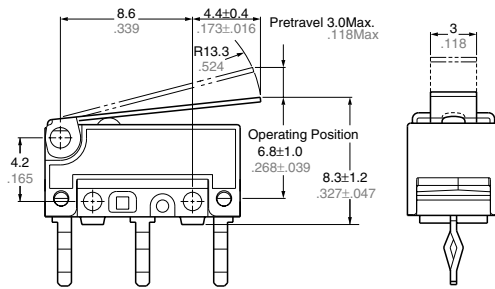

Pretravel, Max. mm inch	3.0 .118	
Movement differential, Max. mm inch	0.5 .020	
Overtravel, Min. mm inch	0.5 .020	
Operating position	Distance from mounting hole, mm inch	6.8±1.0 .267 ± .039
	Distance from stand-off, mm inch	8.3±1.2 .327 ± .047

Simulated roller lever

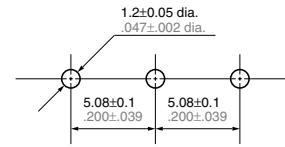
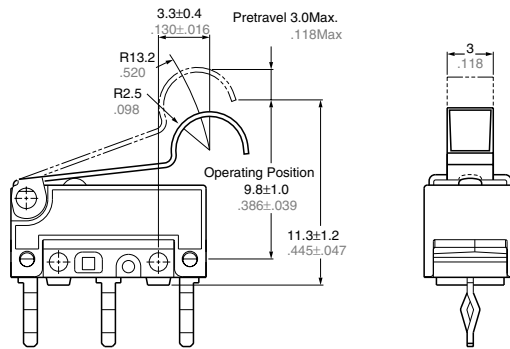

Pretravel, Max. mm inch	3.0 .118	
Movement differential, Max. mm inch	0.5 .020	
Overtravel, Min. mm inch	0.5 .020	
Operating position	Distance from mounting hole, mm inch	9.8±1.0 .386 ± .039
	Distance from stand-off, mm inch	11.3±1.2 .445 ± .047

Roller lever

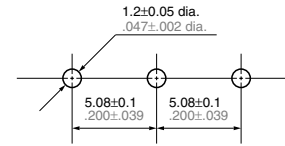
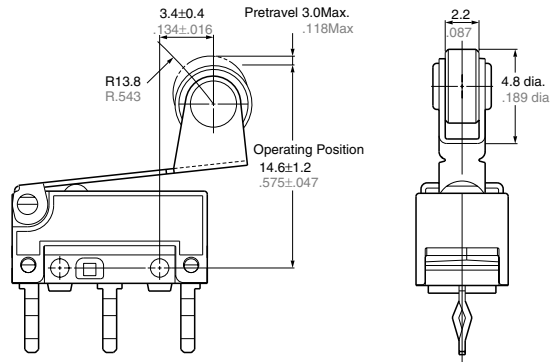

Pretravel, Max. mm inch	3.0 .118	
Movement differential, Max. mm inch	0.5 .020	
Overtravel, Min. mm inch	0.5 .020	
Operating position	Distance from mounting hole, mm inch	13.1±1.0 .516 ± .039
	Distance from stand-off, mm inch	14.6±1.0 .575 ± .039

1-(2) Solder terminal Pin plunger

Mounting hole: 1.2 mm .047 inch

Mounting hole: 2.3 mm .091 inch

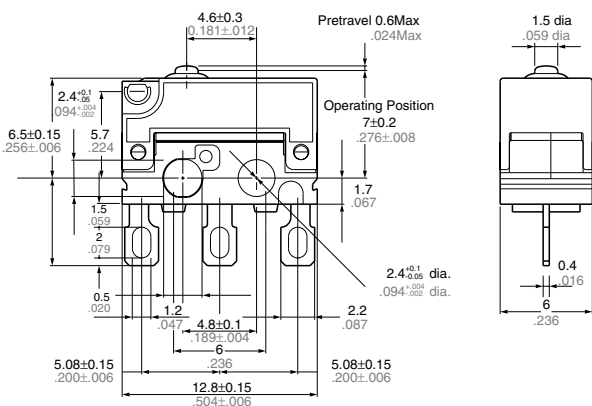
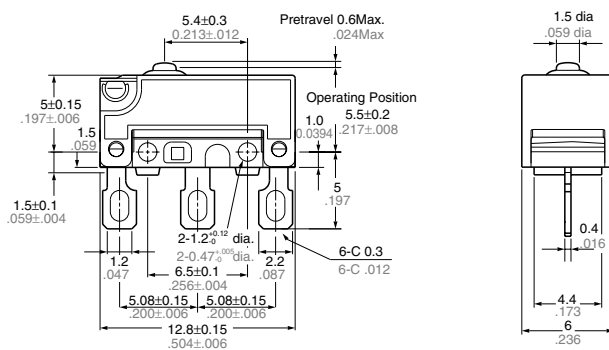

Remarks: Dimensions of the actuator type are the same as corresponding PC board terminal types.

ABJ1,2,3,4,5

2. Immersion protected type

mm inch General tolerance: $\pm 0.25 \pm 0.10$

2-(1) Bottom wire leads type

Pin plunger

Mounting hole: 1.2 mm .047 inch

Mounting hole: 2.3 mm .091 inch

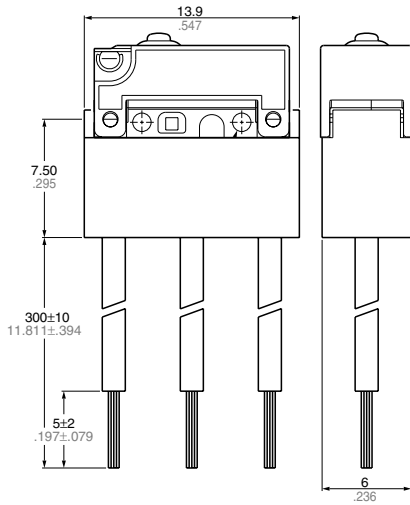

Thickness of the lead wire: 0.3 mm²
 UL/CSA approved type: AWG #20
 Color of the lead wire: COM... Black
 N.C. ... Red
 N.O. ... White

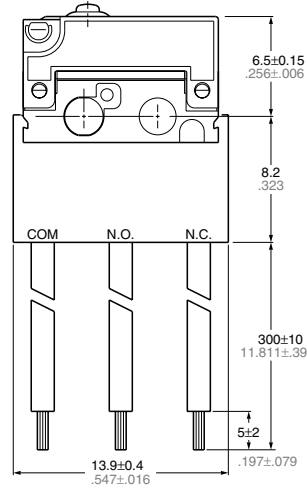

Thickness of the lead wire: 0.3 mm²
 UL/CSA approved type: AWG #20
 Color of the lead wire: COM ...Black
 N.C. ...Red
 N.O. ...White

- Remarks: 1. As for M1.2 type, other dimensions are the same as those of corresponding PC board terminal types.
 As for M2.3 type, other dimensions are the same as those of corresponding solder terminal types.
 2. Dimensions of the actuator type are the same as corresponding PC board terminal types.

Leaf lever

Mounting hole: 3 mm .118 inch

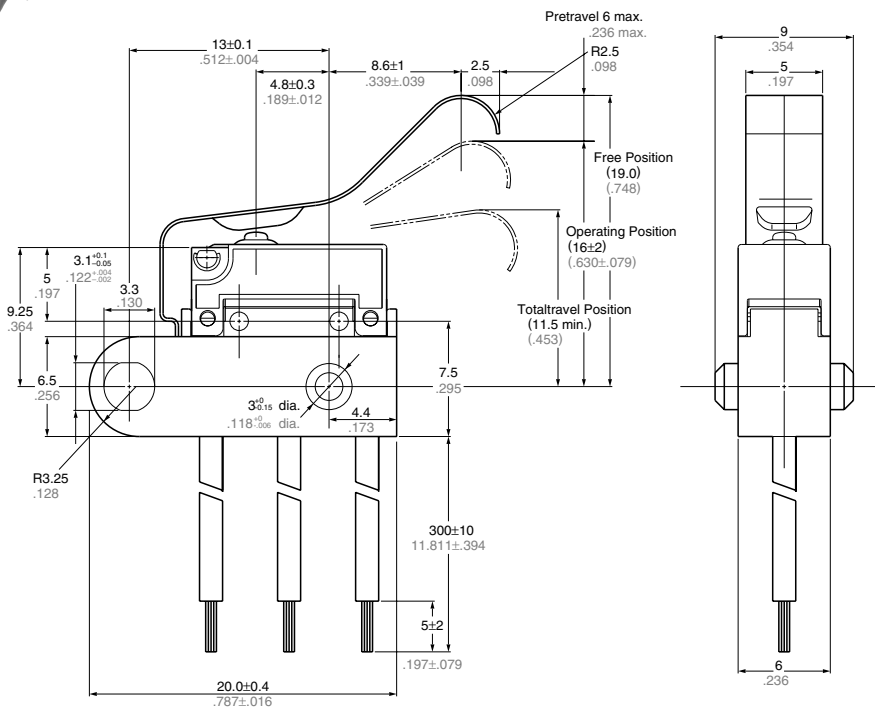
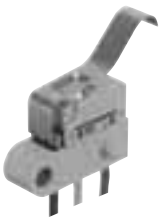

Pretravel, Max. mm inch	6.0 .236
Movement differential, Max. mm inch	1.0 .039
Overtravel, Min mm inch	2.5 .098
Operating position	Distance from mounting hole, mm inch
	16.0 ± 2.0 .630 ± .079

ABJ1,2,3,4,5

mm inch General tolerance: $\pm 0.25 \pm 0.10$

2-(2) Side wire leads type
 Fixed pin type
 Right side pin type
 Right wire leads type

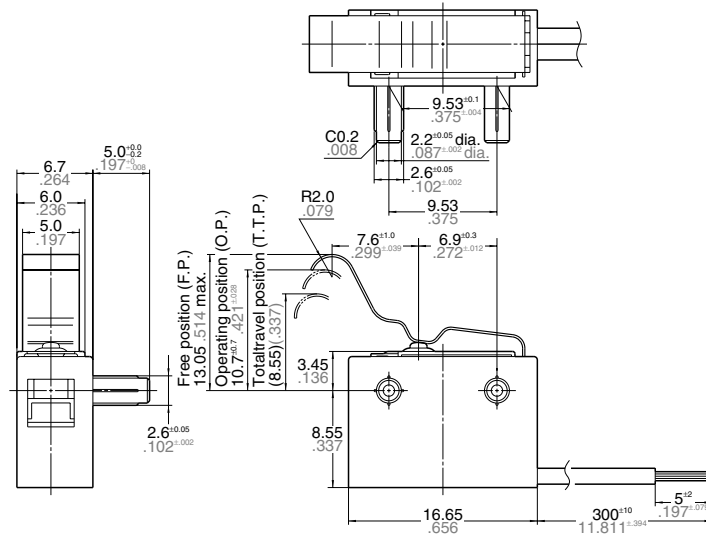
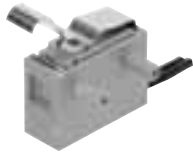

Pretravel, Max. mm inch		2.6 .102
Movement differential, Max. mm inch		0.5 .020
Overtravel, Min mm inch		1.4 .055
Operating position	Distance from mounting hole, mm inch	10.7 \pm 0.7 .421 \pm .028

Left wire leads type

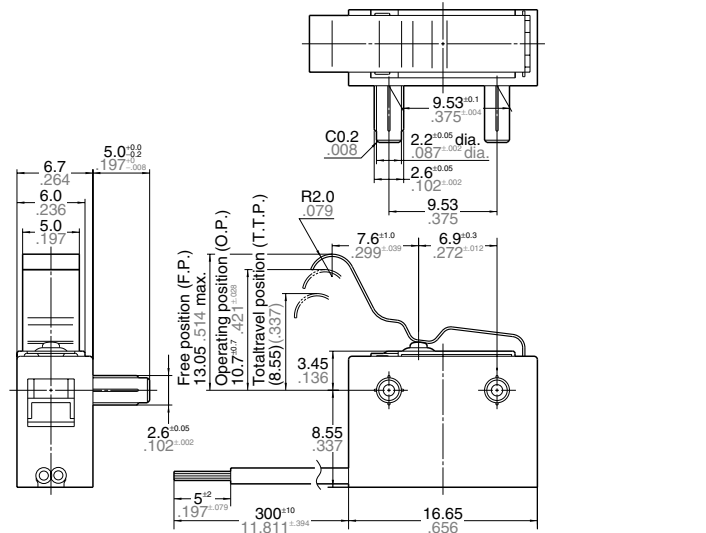
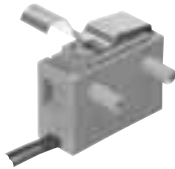

Pretravel, Max. mm inch		2.6 .102
Movement differential, Max. mm inch		0.5 .020
Overtravel, Min mm inch		1.4 .055
Operating position	Distance from mounting hole, mm inch	10.7 \pm 0.7 .421 \pm .028

Left side pin type
 Right wire leads type

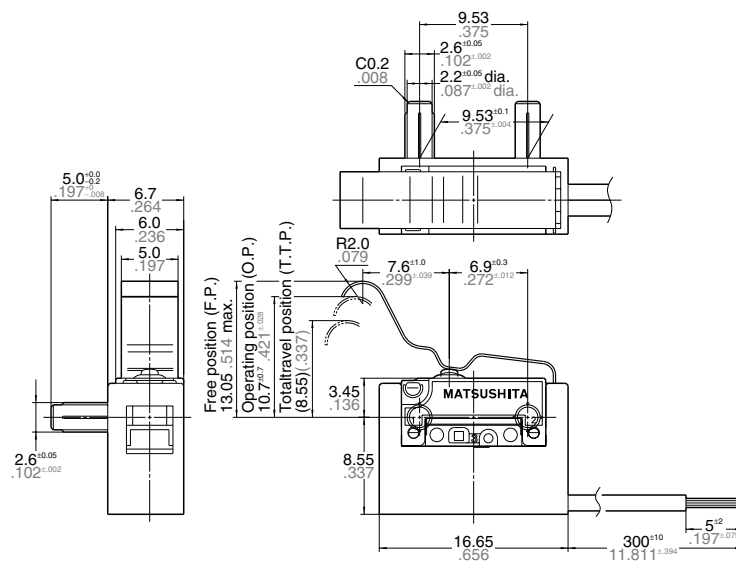
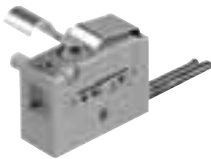

Pretravel, Max. mm inch		2.6 .102
Movement differential, Max. mm inch		0.5 .020
Overtravel, Min mm inch		1.4 .055
Operating position	Distance from mounting hole, mm inch	10.7 \pm 0.7 .421 \pm .028

ABJ1,2,3,4,5

Left wire leads type

mm inch General tolerance: $\pm 0.25 \pm 0.010$

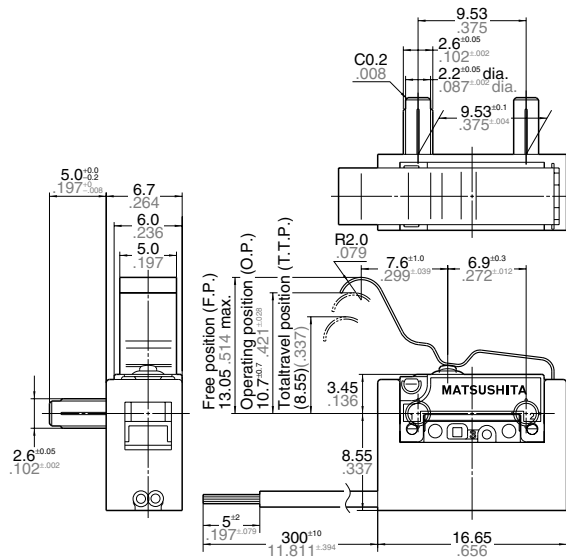

Pretravel, Max. mm inch	2.6 .102
Movement differential, Max. mm inch	0.5 .020
Overtravel, Min mm inch	1.4 .055
Operating position	Distance from mounting hole, mm inch
	10.7 \pm 0.7 .421 \pm .028

Mounting hole 3mm .118 inch type

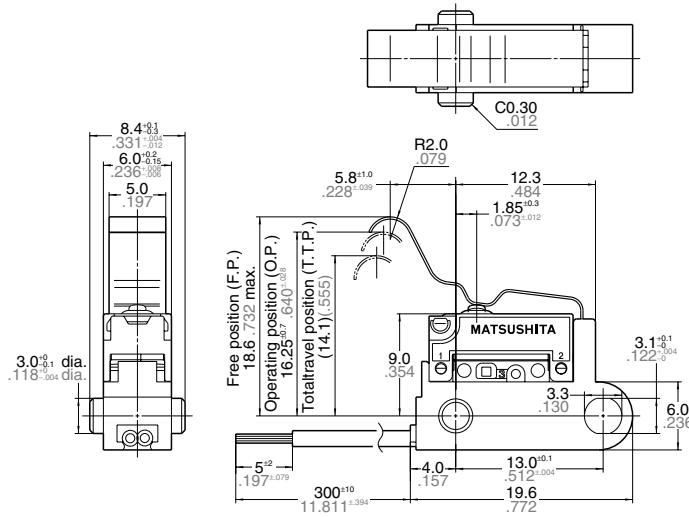
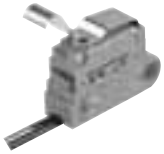

Pretravel, Max. mm inch	2.6 .102
Movement differential, Max. mm inch	0.5 .020
Overtravel, Min mm inch	1.4 .055
Operating position	Distance from mounting hole, mm inch
	16.25 \pm 0.7 .640 \pm .028

ABJ1,2,3,4,5

3. Immersion protected type (Bottom wire leads type) Long stroke type

Mounting hole: 2.3 mm .091 inch

mm inch General tolerance: $\pm 0.25 \pm 0.10$

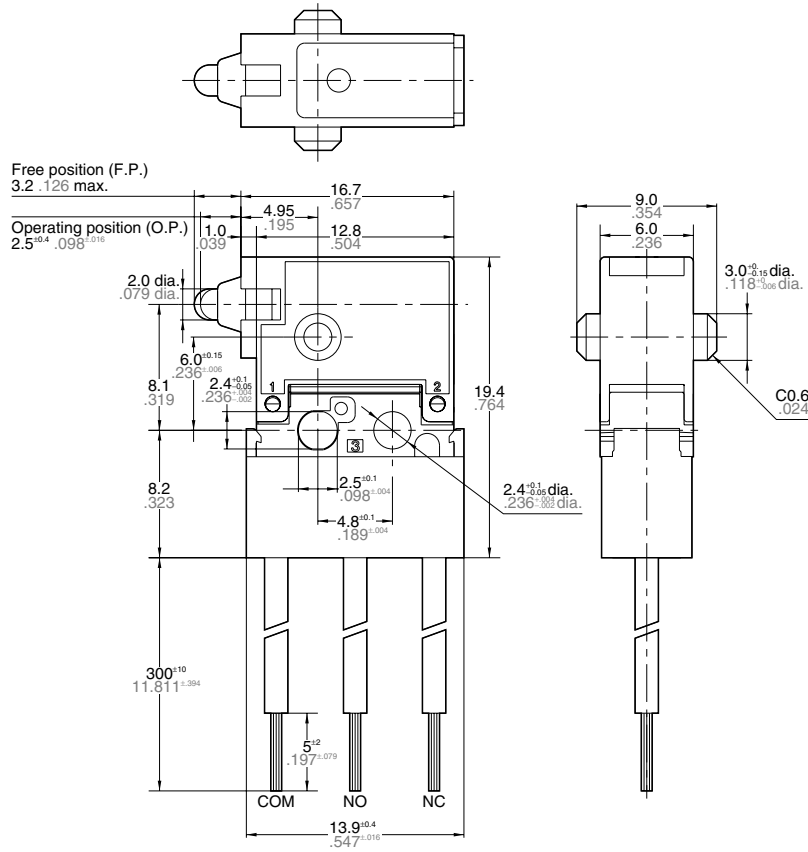

Movement differential, Max. mm inch	0.5 .020
Overtravel, Min mm inch	2.0 .079
Operating position	2.5 ± 0.4 .098 ± 0.16

X-ON Electronics

Largest Supplier of Electrical and Electronic Components

Click to view similar products for [Basic / Snap Action Switches](#) category:

Click to view products by [Panasonic](#) manufacturer:

Other Similar products are found below :

[83228001](#) [01.098.1358.1](#) [602EN1-6B](#) [602EN532](#) [602EN535-RB](#) [602HE5-RB1](#) [604HE162](#) [604HE223-6B](#) [624HE17-RB](#) [6HM89](#) [6PA78-JM](#)
[6SE1](#) [6SX1-H58](#) [70500840](#) [MBD5B1](#) [MBH2731](#) [73-316-0012](#) [79211759](#) [79211923](#) [79218589](#) [7AS12](#) [ML-1155](#) [ML-1376](#) [831010C3.0](#)
[831060C3.TL](#) [831090C2.EL](#) [83131904](#) [84212012](#) [8AS239](#) [8HM73-3](#) [903VB1-PG](#) [914CE1-6G](#) [PL-100](#) [11SM1077-H4](#) [11SM1077-H58](#)
[11SM1-TN107](#) [11SM405](#) [11SM703-T](#) [11SM8423-H2](#) [11SX37-T](#) [11SX48-H58](#) [11SX55-H58](#) [11SM2442-T](#) [11SM76-T](#) [11SM77-H58](#)
[11SM77-T](#) [11SM863-T](#) [11SM866](#) [11SX47-H58](#) [A7CN-1M-1-LEFT](#)