



## Features

- RoHS compliant\*
- Power rating at 70 °C: CR0603 - 0.10 W, CR0805 - 0.125 W, CR1206 - 0.25 W
- Tight tolerances of bottom electrode width
- Suitable for all types of soldering processes
- Three layer contacting process with nickel barrier prevents leaching and provides excellent solderability
- Paper tape on reel for automatic placement

## CR0603/CR0805/CR1206 - Chip Resistors

### Electrical Characteristics

Characteristic	Model CR0603	Model CR0805	Model CR1206
Power Rating @ 70 °C	1/10 W	1/8 W	1/4 W
Operating Temperature Range	-55 °C to +155 °C		
Derated to 0 Load at	+155 °C		
Maximum Working Voltage	50 V	150 V	200 V
Maximum Overload Voltage	100 V	300 V	400 V
Resistance Range: 1 % E-96 + E-24	10 ohms ≤ R ≤ 1M ohms ±100 PPM/°C		
Resistance Range: 5 % E-24	1M ohms < R ≤ 10M ohms ±200 PPM/°C		
Zero Ohm Jumper <0.05 ohm Rated / Maximum Current	1 A / 2.5 A	2 A / 5 A	2 A / 5 A

AEC-Q200: Contact Bourns to confirm availability.

For Standard Values Used in Capacitors, Inductors, and Resistors, [click here](#).

### Chip Dimensions

Dimension	Model CR0603	Model CR0805	Model CR1206
L	$\frac{1.60 \pm 0.10}{(0.063 \pm 0.004)}$	$\frac{2.00 \pm 0.15}{(0.079 \pm 0.006)}$	$\frac{3.20 \pm 0.25}{(0.126 \pm 0.010)}$
W	$\frac{0.80 \pm 0.10}{(0.031 \pm 0.004)}$	$\frac{1.25 \pm 0.15}{(0.049 \pm 0.006)}$	$\frac{1.60 \pm 0.15}{(0.063 \pm 0.006)}$
H	$\frac{0.45 \pm 0.10}{(0.018 \pm 0.004)}$	$\frac{0.50 \pm 0.10}{(0.020 \pm 0.004)}$	$\frac{0.60 \pm 0.15}{(0.024 \pm 0.006)}$
l1	$\frac{0.30 \pm 0.20}{(0.012 \pm 0.008)}$	$\frac{0.40 \pm 0.20}{(0.016 \pm 0.008)}$	$\frac{0.50 \pm 0.25}{(0.020 \pm 0.010)}$
l2	$\frac{0.30 \pm 0.20}{(0.012 \pm 0.008)}$	$\frac{0.40 \pm 0.20}{(0.016 \pm 0.008)}$	$\frac{0.50 \pm 0.20}{(0.020 \pm 0.010)}$

DIMENSIONS:  $\frac{\text{MM}}{\text{(INCHES)}}$

### Derating Curve

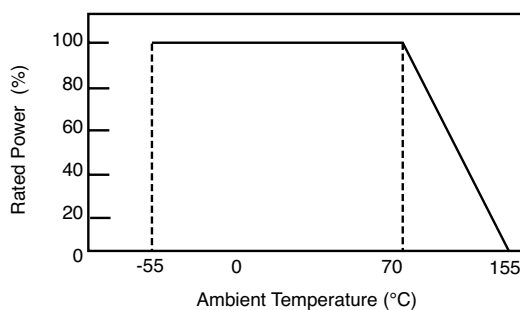

### Characteristic Data

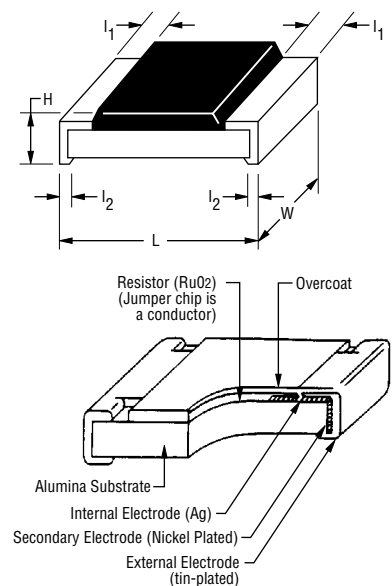

\*RoHS Directive 2002/95/EC Jan. 27, 2003 including annex and RoHS Recast 2011/65/EU June 8, 2011. Specifications are subject to change without notice. The device characteristics and parameters in this data sheet can and do vary in different applications and actual device performance may vary over time. Users should verify actual device performance in their specific applications.

# CR0603/CR0805/CR1206 - Chip Resistors

# BOURNS®

## Performance Characteristics

Test	Procedure	Method	Specification	Test Limits $\Delta R$	
				1 %	5 %
DC Resistance	--	MIL-STD-202 303 EIA RS-396 4.4	MIL-R-55342D 4.7.2	$\leq \pm 1 \%$	$\leq \pm 5.0 \%$
Low Temperature Operation	-55 °C, 1 hour "OFF"; 45 minutes "ON"	MIL-R-55342D 4.7.4 EIA RS-396 4.6	MIL-R-55342D 4.7.4	$\leq \pm(0.5 \% + 0.05 \Omega)$	$\leq \pm(1.0 \% + 0.05 \Omega)$
Short time Overload	Rated Voltage x 2.5, 5 seconds: CR0603: 100 V max. CR0805: 300 V max. CR1206: 400 V max.	MIL-R-55342D 4.7.5 EIA RS-396 4.7	MIL-R-55342D 4.7.5	$\leq \pm(1 \% + 0.05 \Omega)$	$\leq \pm(2 \% + 0.05 \Omega)$
High Temperature Exposure	+125 °C, 1000 hours	MIL-R-55342D 4.7.6 EIA RS-396 4.8	MIL-R-55342D 4.7.6	$\leq \pm(1.0 \% + 0.05 \Omega)$	$\leq \pm(2.0 \% + 0.1 \Omega)$
Resistance to Solder Heat	260 °C, 10 seconds	MIL-R-55342D 4.7.7	MIL-R-55342D 4.7.7	$\leq \pm(0.5 \% + 0.05 \Omega)$	$\leq \pm(1.0 \% + 0.05 \Omega)$
Moisture Resistance	90-98 % RH, 10 cycles	MIL-STD-202 106D EIA RS-396 4.9	MIL-R-55342D 4.7.8	$\leq \pm(0.5 \% + 0.05 \Omega)$	$\leq \pm(2.0 \% + 0.05 \Omega)$
Load Life	+70 °C; 1.5 hours "ON", 0.5 hours "OFF"; 1000 hours	MIL-STD-202 108 Condition D EIA RS-396 4.12	MIL-R-55342D 4.7.10	$\leq \pm(1.0 \% + 0.05 \Omega)$	$\leq \pm(3.0 \% + 0.1 \Omega)$
Solderability	+235 °C; 3 seconds	MIL-STD-202 208 EIA RS-396 4.11	MIL-R-55342D 4.7.11	$\geq 95 \%$ of area covered	
Terminal Strength	Pull Test	MIL-R-55342D 4.7.12	MIL-R-55342D 4.7.12	$\geq 500$ g	
Current Noise	Quan-Tech Model 315B	MIL-STD-202 308	MIL-R-55342D 6.6	R $\leq$ 1 kW; 1 mV/V max. R $\leq$ 10 kW; 3 mV/V max. R $\leq$ 100 kW; 6 mV/V max. R $\leq$ 1 MW; 10 mV/V max.	
Humidity, Steady State	+40 °C; 90-95 % RH, 1344 hours	MIL-STD-202 103B Condition D	--	$\leq \pm(2.5 \% + 0.05 \Omega)$	$\leq \pm(2.5 \% + 0.05 \Omega)$
Salt Spray	96 hours	MIL-STD-202 101D Condition A	--	$\leq \pm(1.0 \% + 0.2 \Omega)$	$\leq \pm(1.0 \% + 0.1 \Omega)$
Vibration	10-2000 Hz, 6 hours	MIL-STD-202 201A	--	$\leq \pm(0.5 \% + 0.1 \Omega)$	$\leq \pm(1.0 \% + 0.1 \Omega)$
Voltage Coefficient	--	MIL-STD-202 309	--	$\leq 100$ ppm/V	
Insulation Resistance	Test potential: 500V CR0603: 100 V	MIL-STD-202 302 Condition B	--	$\geq 1$ G $\Omega$	
Dielectric Withstanding Voltage	--	MIL-STD-202 301	--	CR0805, CR1206: $\geq 500$ V CR0603: $\geq 300$ V	
Drop Test	1 m	MIL-STD-202 203B	--	$\leq \pm(0.5 \% + 0.1 \Omega)$	$\leq \pm(1 \% + 0.1 \Omega)$
Bending Test	5 mm/90 mm, 10 seconds	--	--	$\leq \pm(1 \% + 0.05 \Omega)$	$\leq \pm(1 \% + 0.05 \Omega)$
Thermal Shock	-55 °C for 30 minutes, +155 °C for 30 minutes, 5 cycles	IEC 60115-1-4.19	--	$\leq \pm(0.5 \% + 0.05 \Omega)$	$\leq \pm(1 \% + 0.05 \Omega)$
Resistance to Dry Heat	125 $\pm$ 5 °C for 96 $\pm$ 4 hours	IEC 60115-1-4.23.2	--	$\leq \pm(1 \% + 0.05 \Omega)$	$\leq \pm(2 \% + 0.1 \Omega)$

Specifications are subject to change without notice.  
The device characteristics and parameters in this data sheet can and do vary in different applications and actual device performance may vary over time.  
Users should verify actual device performance in their specific applications.

# CR0603/CR0805/CR1206 - Chip Resistors

**BOURNS®**

## Soldering Profile for RoHS Compliant Chip Resistors and Arrays

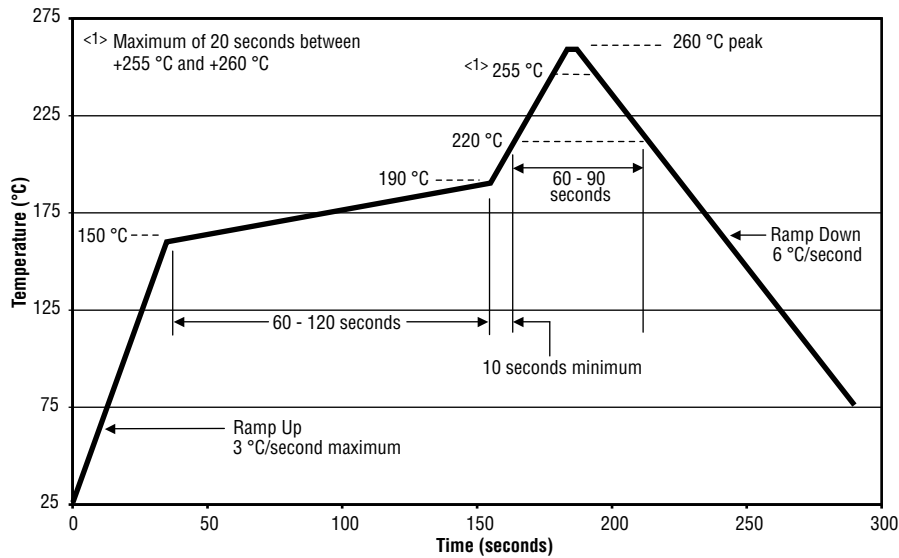

## Packaging Dimensions (Conforms to EIA RS-481A)

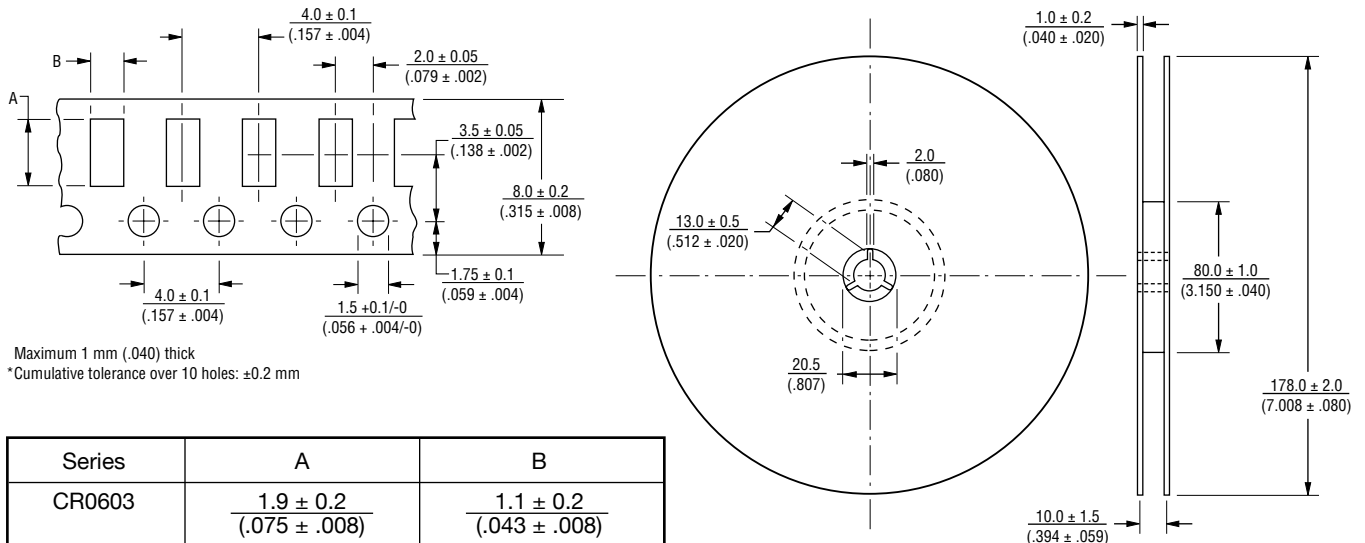

Series	A	B
CR0603	$\frac{1.9 \pm 0.2}{(.075 \pm .008)}$	$\frac{1.1 \pm 0.2}{(.043 \pm .008)}$
CR0805	$\frac{2.4 \pm 0.2}{(.094 \pm .008)}$	$\frac{1.65 \pm 0.2}{(.065 \pm .008)}$
CR1206	$\frac{3.57 \pm 0.2}{(.161 \pm .008)}$	$\frac{2.00 \pm 0.2}{(.079 \pm .008)}$

DIMENSIONS:  $\frac{\text{MM}}{\text{(INCHES)}}$

Marking on reel: Part number, quantity, resistance value and tolerance, date code.

Specifications are subject to change without notice.

The device characteristics and parameters in this data sheet can and do vary in different applications and actual device performance may vary over time. Users should verify actual device performance in their specific applications.

# CR0603/CR0805/CR1206 - Chip Resistors

**BOURNS®**

## Resistor Markings

CR0603  
CR0805  
CR1206



E-24 marking  
Value = 10K ohms

CR0805  
CR1206



E-96 marking  
Value = 44.2K ohms

CR0603  
EIA-96 Marking



1 % marking  
Value = 12.4K ohms

## Marking Explanation

- E-24: 3 digits, first two digits are significant, third digit is number of zeros.  
Letter R is decimal point.
- E-96: 4 digits, first three digits are significant, fourth digit is number of zeros.  
Letter R is decimal point.  
0603 E-96: EIA-96 marking (see table below).

## EIA-96 Marking for CR0603, 1 %

Code	R Value	Code	R Value	Code	R Value	Code	R Value	Code	R Value	Code	R Value	Code	R Value	Code	R Value
01	100	13	133	25	178	37	237	49	316	61	422	73	562	85	750
02	102	14	137	26	182	38	243	50	324	62	432	74	576	86	768
03	105	15	140	27	187	39	249	51	332	63	442	75	590	87	787
04	107	16	143	28	191	40	255	52	340	64	453	76	604	88	806
05	110	17	147	29	196	41	261	53	348	65	464	77	619	89	825
06	113	18	150	30	200	42	267	54	357	66	475	78	634	90	845
07	115	19	154	31	205	43	274	55	365	67	487	79	649	91	866
08	118	20	158	32	210	44	280	56	374	68	499	80	665	92	887
09	121	21	162	33	215	45	287	57	383	69	511	81	681	93	909
10	124	22	165	34	221	46	294	58	392	70	523	82	698	94	931
11	127	23	169	35	226	47	301	59	402	71	536	83	715	95	953
12	130	24	174	36	232	48	309	60	412	72	549	84	732	96	976

This table shows the first two digits for the three-digit EIA-96 part marking scheme. The third character is a letter multiplier:  
Y=10<sup>-2</sup> X=10<sup>-1</sup> A=10<sup>0</sup> B=10<sup>1</sup> C=10<sup>2</sup> D=10<sup>3</sup> E=10<sup>4</sup> F=10<sup>5</sup>



## X-ON Electronics

Largest Supplier of Electrical and Electronic Components

*Click to view similar products for [Multilayer Ceramic Capacitors MLCC - SMD/SMT](#) category:*

*Click to view products by [Bourns](#) manufacturer:*

Other Similar products are found below :

[M39014/01-1467](#) [M39014/02-1218V](#) [M39014/02-1225V](#) [M39014/02-1262V](#) [M39014/02-1301](#) [M39014/22-0631](#) [1210J5000102JCT](#)  
[1210J2K00102KXT](#) [1210J5000103KXT](#) [1210J5000223KXT](#) [D55342E07B379BR-TR](#) [D55342E07B523DR-T/R](#) [1812J1K00103KXT](#)  
[1812J1K00473KXT](#) [1812J2K00680JCT](#) [1812J4K00102MXT](#) [1812J5000102JCT](#) [1812J5000103JCT](#) [1812J5000682JCT](#) [NIN-FB391JTRF](#)  
[NIN-FC2R7JTRF](#) [NPIS27H102MTRF](#) [C1206C101J1GAC](#) [C1608C0G1E472JT000N](#) [C2012C0G2A472J](#) [2220J2K00101JCT](#)  
[KHC201E225M76N0T00](#) [1812J1K00222JCT](#) [1812J2K00102KXT](#) [1812J2K00222KXT](#) [1812J2K00472KXT](#) [2-1622820-7-CUT-TAPE](#)  
[2220J3K00102KXT](#) [2225J2500824KXT](#) [CCR07CG103KM](#) [CGA2B2C0G1H010C](#) [CGA2B2C0G1H040C](#) [CGA2B2C0G1H050C](#)  
[CGA2B2C0G1H060D](#) [CGA2B2C0G1H070D](#) [CGA2B2C0G1H151J](#) [CGA2B2C0G1H1R5C](#) [CGA2B2C0G1H2R2C](#) [CGA2B2C0G1H3R3C](#)  
[CGA2B2C0G1H680J](#) [CGA2B2C0G1H6R8D](#) [CGA2B2X8R1H221K](#) [CGA2B2X8R1H472K](#) [CGA3E1X7R1C474K](#)  
[CGA3E2C0G1H561JT0Y0N](#)