



Operation and Maintenance Manual for the TD-100  
and MT-100 Handpieces  
(Intelliheat and Heatwise/Tempwise Systems)

P/N 5050-0532 Rev A



<b>TITLE</b>	<b>PAGE</b>
Safety Guidelines .....	3
Handpiece Connection.....	3
Tip Cartridge Installation .....	3
Accessory and Replacement Parts.....	4
Tips.....	5
Corrective Maintenance .....	10
Service .....	10
PACE WORLDWIDE LIMITED WARRANTY STATEMENT.....	11
Contact Information.....	12

## Safety Guidelines

The following are safety precautions that personnel must understand and follow when using or servicing this product.

1. **POTENTIAL SHOCK HAZARD** - Repair procedures on PACE products should be performed by Qualified Service Personnel only. Line voltage parts may be exposed when the equipment is disassembled. Service personnel must avoid contact with these parts when troubleshooting the product.
2. To prevent personnel injury, adhere to safety guidelines in accordance with OSHA and other applicable safety standards.
3. Heater Cartridge Tips are hot when the handpiece is powered on and for a period of time after power off. **DO NOT** touch the cartridge. Severe burns may result.
4. PACE Tip & Tool Stands and handpiece cubbies are designed specifically for use with the associated handpiece and houses it in a manner that protects the user from accidental burns. Always store the handpiece in its holder. Be sure to place the handpiece in its holder after use and allow for cooling before storing.
5. Always use PACE systems in a well ventilated area. A fume extraction system such as those available from PACE are highly recommended to help protect personnel from solder flux fumes.
6. Exercise proper precautions when using chemicals (e.g., solder paste). Refer to the Material Safety Data Sheet (MSDS) supplied with each chemical and adhere to all safety precautions recommended by the manufacturer.

## Handpiece Connection

Connect the handpiece connector plug into the Power Receptacle in the following manner.

1. Align guide on the connector with slot on power receptacle.
2. Insert connector into power receptacle.
3. Turn the connector housing clockwise to lock in place.

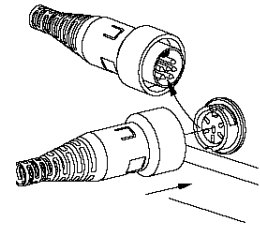

## Tip Cartridge Installation

Both TD-100 and MT-100 tip cartridges are fitted with a key lock device. This feature ensures that tip cartridges are held firmly in position and will maintain their orientation. MT-100 tip cartridges CANNOT be fully inserted into the TD-100 and TD-100 tip cartridges CANNOT be fully inserted into the MT-100. To install a tip cartridge, please follow the procedure below.

1. Line up the key lock feature on the tip cartridge with the notch on the front of the handpiece.
2. Push the tip cartridge all the way into the handpiece.

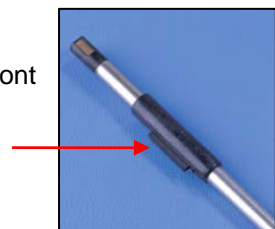

To remove a tip cartridge, use the included **hot grip removal pad** to grasp the tip cartridge and pull the tip cartridge out of the handpiece. Be careful when completing this procedure as the tip cartridge may be hot and direct contact can cause injury.



*Tips*









***cartridges can be changed at any time and without turning off the power to the unit.***



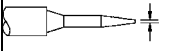
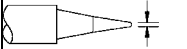

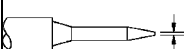
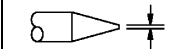
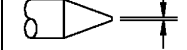
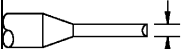
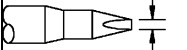
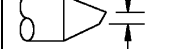

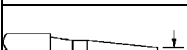
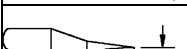

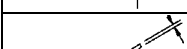
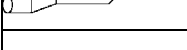
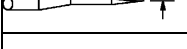
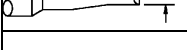
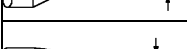
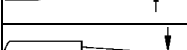

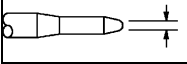
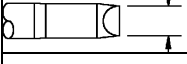
**Accessory and Replacement Parts**

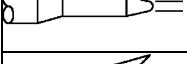

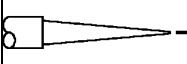
	<b>Description</b>	<b>PACE Part Number</b>
	Tip Case – Holds 10 Tips (Tips not included)	1310-0034-P1
	Tip Stand – Allows for an additional 10 tips to be stored on the tool stand. (Shown with TD-100 Tool Stand and tips not included)	1321-0639-P1
	TD-100 Handpiece (Tip cartridge not included) Heatwise/Tempwise systems only (Red Connector)	6010-0132-P1  6993-0243-P1 Handpiece with tip and tool stand
	Replacement TD-100 cord assembly Heatwise/Tempwise systems only (Red Connector)	3008-0131-P1
	TD-100 Handpiece (Tip cartridge not included) Intelliheat systems only. (Blue connector)	6010-0147-P1  (6993-0272-P1) Handpiece with tip and tool stand
	Replacement TD-100 cord assembly Intelliheat systems only (Blue connector)	3008-0296-P1
	Replacement O-rings for TD-100. Package of 5.	1213-0090-P5
	TD-100 Tool Stand (TD-100 Handpiece and tips not included)	6019-0079-P1
	MT-100 Handpiece (Tips not included)  Heatwise/Tempwise systems only (Red Connector)	6010-0140-P1 (handpiece only)  6993-0243-P1 Kit with Tip and tool stand
	MT-100 Handpiece (Tips not included)  Intelliheat systems only (Blue Connector)	6010-0148-P1 (handpiece only)  6993-0264-P1 Kit with Tip and tool stand
	MT-100 Tool Stand	6019-0080-P1
	Hot Grip Removal Pad	1100-0307-P1

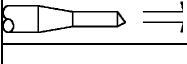
## Available Tips

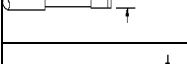
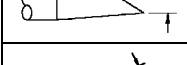
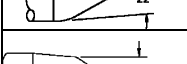
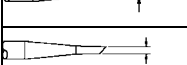

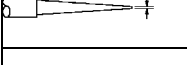
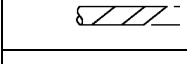
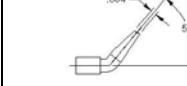
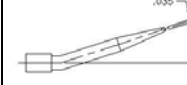
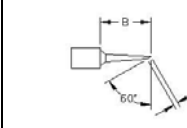
A wide variety of tip cartridges are available for use with the TD-100 and the MT-100 Handpieces. Please refer to the table below for available tip cartridge styles.

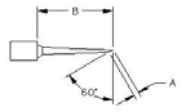
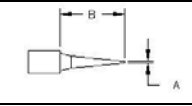
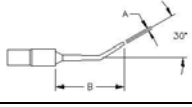
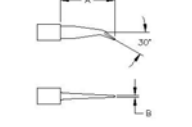
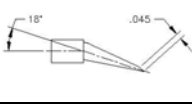
	<b>PACE P/N</b>	<b>Description</b>
	1124-0001-P1	1/32" Conical Sharp Extended
	1124-0002-P1	1/64" Conical Sharp
	1124-0003-P1	1/64" Conical Sharp Bent 30 Degrees
	1124-0004-P1	1/64" Conical Sharp Extended
	1124-0005-P1	1/32" Conical
	1124-0006-P1	3/128" Conical
	1124-0007-P1	1/16" 90 Degree Chisel
	1124-0008-P1	3/64" 30 Degree Chisel
	1124-0009-P1	3/64" 30 Degree Bevel
	1124-0010-P1	13/64" Chisel
	1124-0011-P1	1/64" 60 Degree Bevel
	1124-0012-P1	1/32" 30 Degree Chisel
	1124-0013-P1	3/32" 30 Degree Chisel
	1124-0014-P1	5/64" 60 Degree Bevel
	1124-0015-P1	1/64" Conical, Sharp, Bent 30 Degrees, Extended
	1124-0016-P1	3/64" Chisel Bent 30 Degrees
	1124-0017-P1	1/16" 60 Degree Chisel
	1124-0018-P1	1/32" Conical Sharp Extended
	1124-0019-P1	1/16" 30 Degree Chisel
	1124-0020-P1	1/8" 90 Degree Chisel

	1124-0021-P1	3/128" Conical Sharp Bent 30 Degrees
	1124-0022-P1	1/16" Conical Sharp
	1124-0023-P1	1/8" 90 Degree Chisel Extended
	1124-0024-P1	1/16" 30 Degree Bevel
	1124-0025-P1	1/16" Conical Sharp Extended
	1124-0026-P1	1/16" Chisel Bent 30 Degrees
	1124-0027-P1	3/128" Conical Sharp, Extended
	1124-0028-P1	3/64" Chisel, Bent 30 Degrees, Extended
	1124-0029-P1	1/32" 30 Degree Bevel
	1124-0030-P1	1/32" Conical Sharp
	1124-0031-P1	Heat Staking
	1124-0032-P1	MiniWave
	1124-0033-P1	Angled MiniWave, 3.3 mm
	1124-0034-P1	Single Sided Chisel
	1124-0035-P1	Angled MiniWave, 2.4mm
	1124-0036-P1	1/128" Conical
	1124-0037-P1	1/4 Flat Blade
	1124-0038-P1	Single Sided Chisel, Fine Pitch
	1124-0039-P1	Angled MiniWave, Fine Pitch
	1124-0040-P1	MicroFine Single Sided Chisel, 0.9mm (.035")

	1124-0041-P1	MicroFine Single Sided Chisel, 1.1mm (.045")
	1124-0042-P1	MicroFine Conical, 0.25mm (.01")
	1124-0043-P1	MicroFine Bent Conical, 0.75mm (.03")
	1124-0044-P1	MicroFine Bent Conical, 0.5mm (.02")
	1124-0045-P1	Angled Micro-Wave Tip
	1124-0046-P1	Micro-Wave Tip

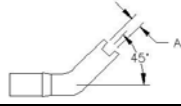
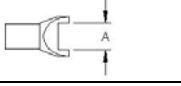
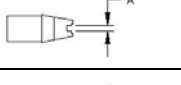
**Surface Mount Removal Tips for TD-100 Soldering Iron**

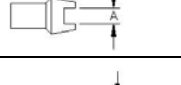
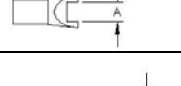
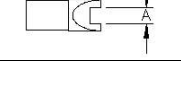
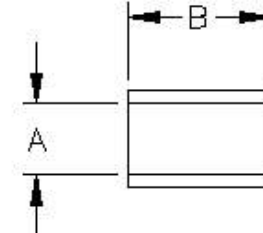
	Component Type	Dimension A	Dimension B	Part Number
	Chip 402 Angle	2.2mm (.085")		1124-0518-P1
	Chip 1808	5mm (.195")		1124-0520-P1
	Chip 402	1mm (.04")		1124-0521-P1
	SOT 23	1.8mm (.07")		1124-0522-P1
	SOT 89	2.8mm (.11")		1124-0523-P1
	Chip 1206	3.6mm (.142")		1124-0524-P1
	Chip 0805	2.4mm (.095")		1124-0525-P1
	SOIC 14/16	5.2mm (.205")	10.5mm (.415")	1124-0504-P1
	SOIC 20	9.6mm (.377")	13.6mm (.535")	1124-0505-P1
	SOP 28	10.8mm (.426")	18.6mm (.734")	1124-0506-P1
	SOP 40	11.9mm (.467")	25.7mm (1.01")	1124-0507-P1
	SOP 44	13.1mm (.516")	28.4mm (1.12")	1124-0508-P1
	TSOP 56	18.8mm (.739")	14.1mm (.557")	1124-0509-P1
	TSOP 28	12mm (.471")	8.5mm (.333")	1124-0510-P1
	SOIC 8	5.1mm (.202")	4.65mm (.183")	1124-0519-P1
	TSOP 40	18.8mm (.74")	10.4mm (.410")	1124-0526-P1

	PLCC 28 Socket	9.3mm (.365")	9.3mm (.365")	1124-0511-P1
	PLCC 32	14.2mm (.561")	11.7mm (.459")	1124-0512-P1
	PLCC 44	16.8mm (.662")	16.8mm (.662")	1124-0513-P1
	QFP 144	20.6mm (.81")	20.6mm (.810")	1124-0514-P1
	PLCC 28	11.8mm (.465")	11.8mm (.465")	1124-0515-P1
	QFP 100/128	22mm (.865")	16mm (.628")	1124-0516-P1
	PLCC 20	9.3mm (.365")	9.3mm (.365")	1124-0527-P1
	PLCC 18	7.6mm (.3")	12.8mm (.505")	1124-0528-P1
	TQFP 80	12.5mm (.491")	12.5mm (.491")	1124-0529-P1
	PLCC 52	19.4mm (.762")	19.4mm (.762")	1124-0530-P1
	QFP 80/100	26.6mm (1.05")	26.6mm (1.05")	1124-0531-P1
		Blade	10.8mm (.425")	
Blade		16mm (.630")		1124-0502-P1
Blade		21.2mm (.835")		1124-0503-P1
Blade		25mm (.984")		1124-0532-P1

**Surface Mount Removal Tips for MT-100 MiniTweez**

	<u>PACE P/N</u>	<u>Description</u>
	1124-1001-P1	Chip 0.2mm (.008")
	1124-1002-P1	Chip 0.5mm (.02")
	1124-1003-P1	Chip 1mm (.04")

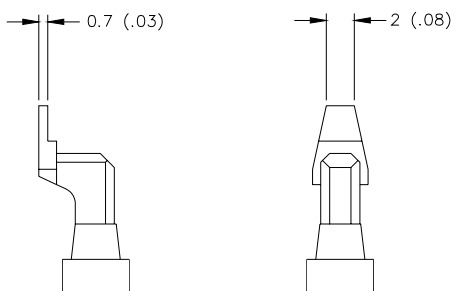
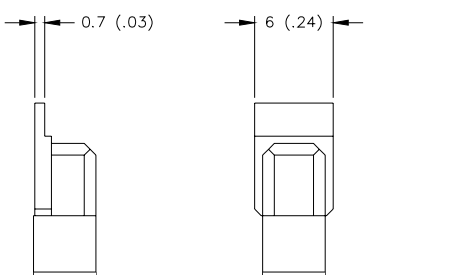
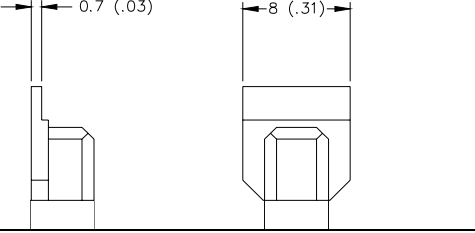
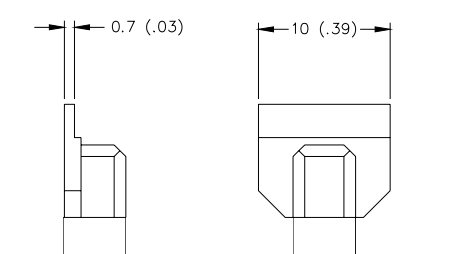
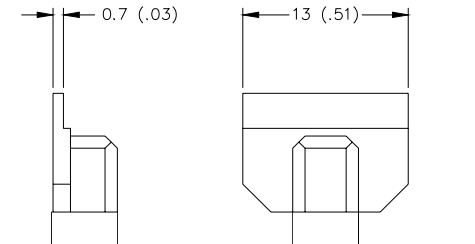

	1124-1004-P1	Chip 2mm (.08")
	1124-1005-P1	SOP 6 6mm (.24")
	1124-1006-P1	SOP 8 8mm (.31")
	1124-1007-P1	SOP 10 10 mm (.39")
	1124-1008-P1	SOP 13 13 mm (.51")

### **Corrective Maintenance**

The TD 100 handpiece features a replaceable O-ring that protects the contact area from flux fume and other contamination. The O-ring may need to be replaced over time. To replace the O-ring follow the procedure below:

1. Disconnect the TD 100 from the power source
2. Remove the tip cartridge
3. Unscrew the cap from the back of the TD 100
4. Slide the connector assembly out of the handle

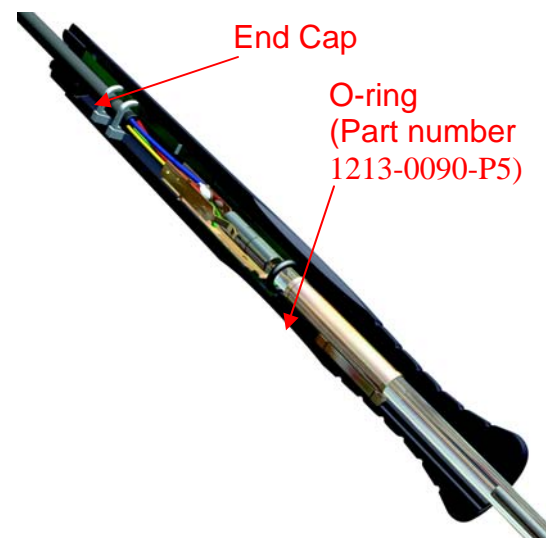

5. Remove and replace the old O-ring from the connector assembly (Old "O-ring" may remain in handle)
6. Reinstall the connector assembly. Be sure to line up the keyways on the handle and connector assembly. Do not force the connector assembly into the handle.
7. Reinstall the cap and make sure it is fully seated against the handle
8. Install a tip cartridge

The O-rings on the MT-100 do not need to be replaced.

Tip Cartridge 

### Handpiece Troubleshooting

Most malfunctions are simple and easy to correct.

Symptom	Probable Cause	Solution
Handpiece will not heat	Defective Heater	Change Tip Cartridge
	Power Source Malfunction	Contact PACE
	O-Ring has come out and blocked tip from going all of the way in	Check inside handpiece for Oring. Make sure that it has not dislodged or come out of the slot.

### Service

Please contact PACE or your local distributor for service and repair.

### **PACE WORLDWIDE LIMITED WARRANTY STATEMENT**

#### Limited Warranty

Seller warrants to the first user that products manufactured by it and supplied hereunder are free of defects in materials and workmanship for a period of three (3) years from the date of receipt by such user. This Warranty as applied to blowers, motor pumps, x-ray tubes, lenses, optical/lighting probes and cameras is limited to a period of one (1) year. Monitors, computers and other brand equipment supplied but not manufactured by PACE are covered under their respective manufacturer's warranty in lieu of this Warranty.

This warranty does not cover wear and tear under normal use, repair or replacement required as a result of misuse, improper application, mishandling or improper storage. Consumable items such as tips, heaters, filters, etc. which wear out under normal use are excluded. Failure to perform recommended routine maintenance, alterations or repairs made other than in accordance with Seller's directions, or removal or alteration of identification markings in any way will void this warranty. This warranty is available only to the first user, but the exclusions and limitations herein apply to all persons and entities. SELLER MAKES NO OTHER WARRANTY, EXPRESS OR IMPLIED, AND MAKES NO WARRANTY OF MERCHANTABILITY OR FITNESS FOR A PARTICULAR PURPOSE.

Seller will, at its option, repair or replace any defective products at its facility or other location approved by it at no charge to user, or provide parts without charge for installation by the user in the field at user's expense and risk. User will be responsible for all costs of shipping equipment to Seller or other location for warranty service.

EXCEPT FOR THE REMEDY ABOVE DESCRIBED, UNLESS OTHERWISE REQUIRED BY APPLICABLE LAW, SELLER WILL HAVE NO OTHER OBLIGATION WITH REGARD TO ANY BREACH OF WARRANTY OR OTHER CLAIM WITH RESPECT TO THE PRODUCTS, OR LIABILITY FOR ANY DIRECT, INDIRECT, CONSEQUENTIAL, OR INCIDENTAL LOSS OR DAMAGE CAUSED BY OR OCCURRING IN CONNECTION WITH ANY OF THE PRODUCTS.

Warranty service may be obtained by contacting the appropriate PACE Company or local Authorized PACE distributor as set forth below to determine if return of any item is required, or if repairs can be made by the user in the field. Any warranty or other claim with respect to the products must be made with sufficient evidence of purchase and date of receipt, otherwise user's rights under this warranty shall be deemed waived. PACE Incorporated retains the right to make changes to specifications contained herein at any time, without notice. Contact your local authorized PACE Distributor or PACE Incorporated to obtain the latest specifications.

The following are trademarks and/or service marks of PACE, Incorporated, NC, USA:

INSTACAL™, FUMEFLO™, HEATWISE™, PACEWORLDWIDE™, PERMAGROUND™, POWERPORT™, POWERMODULE™, TEMPWISE™, TIP-BRITE™, AUTO-OFF™, and TEKLINK™.

The following are registered trademarks and/or service marks of PACE Incorporated, Southern Pines North Carolina, U.S.A.

ARM-EVAC®, FLO-D-SODR®, MINIWAVE®, PACE®, SENSATEMP®, SNAP-VAC®, SODRTEK®, SODR-X-TRACTOR®, THERMOFLO®, THERMOJET®, THERMOTWEEZ®, VISIFILTER®, THERMO-DRIVE®, and TOOLNET®.

PACE products meet or exceed all applicable military and civilian EOS/ESD, temperature stability and other specifications including MIL STD 2000, ANSI/JSTD 001, IPC7711, and IPC A-610.

Additional copies of this manual or other PACE literature may be obtained from:



[www.paceworldwide.com](http://www.paceworldwide.com)

**PACE Incorporated**  
255 Air Tool Drive  
Southern Pines,  
North Carolina, 28387  
Tel: (877) 882-PACE  
Tel: (910) 695-7223  
Fax: (910) 695-1594

**Pace Europe**  
11 Holdom Avenue  
Bletchley, Milton Keynes,  
United Kingdom, MK1 1QU  
Tel: 011 44 1908 277666  
Fax: 011 44 1908 277777

## **X-ON Electronics**

Largest Supplier of Electrical and Electronic Components

*Click to view similar products for [pace manufacturer](#):*

Other Similar products are found below :

[8883-0111-P5](#) [1121-0690-P5](#) [1124-1004-P1](#) [1128-0003-P1](#) [1128-0019-P1](#) [1128-0012-P1](#) [1128-0001-P1](#) [1121-0416-P1](#) [1121-0399-P1](#) [6993-0317-P1](#) [8007-0510](#) [6993-0210](#) [8007-0455](#) [1128-0013-P1](#) [1121-0680-P5](#) [1121-0003-P2](#) [1121-0313-P1](#) [1124-0003](#) [6993-0316-P1](#) [8883-0931](#)  
[1131-0052-P1](#) [1129-0018-P1](#) [1128-0008-P1](#) [1124-0019-P1](#) [1124-0013-P1](#) [1121-0518-P5](#) [1124-0004-P1](#) [1128-0037-P1](#) [1121-0533-P5](#) [1309-0054-P10](#) [1121-0414-P5](#) [1128-0010-P1](#) [1309-0018-P50](#) [1121-0490-P5](#)