

# Intel<sup>®</sup> I/O Controller Hub 8 (ICH8) Family

## Datasheet

---

*– For the Intel<sup>®</sup> 82801HB ICH8, 82801HR ICH8R, 82801HDH ICH8DH,  
82801HDO ICH8DO, 82801HBM ICH8M, and 82801HEM ICH8M-E  
I/O Controller Hubs*

*May 2014*



INFORMATION IN THIS DOCUMENT IS PROVIDED IN CONNECTION WITH INTEL® PRODUCTS. NO LICENSE, EXPRESS OR IMPLIED, BY ESTOPPEL OR OTHERWISE, TO ANY INTELLECTUAL PROPERTY RIGHTS IS GRANTED BY THIS DOCUMENT. EXCEPT AS PROVIDED IN INTEL'S TERMS AND CONDITIONS OF SALE FOR SUCH PRODUCTS, INTEL ASSUMES NO LIABILITY WHATSOEVER, AND INTEL DISCLAIMS ANY EXPRESS OR IMPLIED WARRANTY, RELATING TO SALE AND/OR USE OF INTEL PRODUCTS INCLUDING LIABILITY OR WARRANTIES RELATING TO FITNESS FOR A PARTICULAR PURPOSE, MERCHANTABILITY, OR INFRINGEMENT OF ANY PATENT, COPYRIGHT OR OTHER INTELLECTUAL PROPERTY RIGHT. Intel products are not intended for use in medical, life saving, or life sustaining applications.

Intel may make changes to specifications and product descriptions at any time, without notice.

Designers must not rely on the absence or characteristics of any features or instructions marked "reserved" or "undefined." Intel reserves these for future definition and shall have no responsibility whatsoever for conflicts or incompatibilities arising from future changes to them.

The Intel® I/O Controller Hub 8 (ICH8) Family chipset component may contain design defects or errors known as errata which may cause the product to deviate from published specifications. Current characterized errata are available on request.

Contact your local Intel sales office or your distributor to obtain the latest specifications and before placing your product order.

I<sup>2</sup>C is a two-wire communications bus/protocol developed by Philips. SMBus is a subset of the I<sup>2</sup>C bus/protocol and was developed by Intel. Implementations of the I<sup>2</sup>C bus/protocol may require licenses from various entities, including Philips Electronics N.V. and North American Philips Corporation.

Intel® Active Management Technology requires the platform have an Intel® AMT-enabled chipset and network hardware and software, be plugged into a power source, and have a network connection.

Alert on LAN is a trademark of the Intel-IBM Advanced Manageability Alliance and a trademark of IBM.

Intel, Intel SpeedStep and the Intel logo are trademarks of Intel Corporation in the U.S. and other countries.

\*Other names and brands may be claimed as the property of others.

Copyright © 2006–2007, Intel Corporation



## Contents

---

<b>1</b>	<b>Introduction</b> .....	45
1.1	Overview .....	48
1.2	Intel® ICH8 Family High-Level Component Differences .....	55
<b>2</b>	<b>Signal Description</b> .....	57
2.1	Direct Media Interface (DMI) to Host Controller .....	60
2.2	PCI Express* .....	60
2.3	LAN Connect Interface .....	61
2.4	Gigabit LAN Connect Interface .....	61
2.5	Firmware Hub Interface.....	62
2.6	PCI Interface .....	63
2.7	Serial ATA Interface.....	66
2.8	IDE Interface (Mobile Only) .....	68
2.9	LPC Interface.....	69
2.10	Interrupt Interface .....	70
2.11	USB Interface .....	71
2.12	Power Management Interface.....	72
2.13	Processor Interface.....	75
2.14	SMBus Interface.....	77
2.15	System Management Interface.....	77
2.16	Real Time Clock Interface.....	78
2.17	Other Clocks.....	79
2.18	Miscellaneous Signals .....	79
2.19	Intel® High Definition Audio Link.....	80
2.20	Serial Peripheral Interface (SPI) .....	81
2.21	Intel® Quick Resume Technology (Intel® ICH8DH Only) .....	82
2.22	Controller Link .....	82
2.23	Intel® Quiet System Technology (Desktop Only) .....	83
2.24	General Purpose I/O Signals .....	83
2.25	Power and Ground.....	86
2.26	Pin Straps .....	88
	2.26.1 Functional Straps .....	88
	2.26.2 External RTC Circuitry .....	90
<b>3</b>	<b>Intel® ICH8 Pin States</b> .....	91
3.1	Integrated Pull-Ups and Pull-Downs .....	91
3.2	IDE Integrated Series Termination Resistors (Mobile Only).....	92
3.3	Output and I/O Signals Planes and States.....	92
3.4	Power Planes for Input Signals .....	102
<b>4</b>	<b>Intel® ICH8 and System Clock Domains</b> .....	107
<b>5</b>	<b>Functional Description</b> .....	109
5.1	PCI-to-PCI Bridge (D30:F0) .....	109
5.1.1	PCI Bus Interface .....	109
5.1.2	PCI Bridge As an Initiator .....	109
	5.1.2.1 Memory Reads and Writes.....	110
	5.1.2.2 Configuration Reads and Writes .....	110
	5.1.2.3 Locked Cycles .....	110
	5.1.2.4 Target / Master Aborts.....	110
	5.1.2.5 Secondary Master Latency Timer.....	110
	5.1.2.6 Dual Address Cycle (DAC).....	110
	5.1.2.7 Memory and I/O Decode to PCI.....	111
5.1.3	Parity Error Detection and Generation .....	111



5.1.4	PCIRST#	111
5.1.5	Peer Cycles	112
5.1.6	PCI-to-PCI Bridge Model	112
5.1.7	IDSEL to Device Number Mapping	112
5.1.8	Standard PCI Bus Configuration Mechanism	113
5.2	PCI Express* Root Ports (D28:F0,F1,F2,F3,F4,F5)	113
5.2.1	Interrupt Generation	113
5.2.2	Power Management	114
5.2.2.1	S3/S4/S5 Support	114
5.2.2.2	Resuming from Suspended State	114
5.2.2.3	Device Initiated PM_PME Message	114
5.2.2.4	SMI/SCI Generation	115
5.2.3	SERR# Generation	115
5.2.4	Hot-Plug	115
5.2.4.1	Presence Detection	115
5.2.4.2	Message Generation	116
5.2.4.3	Attention Button Detection	116
5.2.4.4	SMI/SCI Generation	117
5.3	Gigabit Ethernet Controller (B0:D25:F0)	118
5.3.1	GbE PCI Bus Interface	118
5.3.1.1	Transaction Layer	118
5.3.1.2	Data Alignment	118
5.3.1.3	Configuration Request Retry Status	119
5.3.2	Error Events and Error Reporting	119
5.3.2.1	Data Parity Error	119
5.3.2.2	Completion with Unsuccessful Completion Status	119
5.3.3	Ethernet Interface	119
5.3.3.1	MAC/LAN Connect Interface	119
5.3.4	PCI Power Management	120
5.3.4.1	Wake-Up	120
5.3.5	Configurable LEDs	122
5.3.6	Intel® Auto Connect Battery Saver (Mobile Only)	122
5.3.6.1	Partial and Full Power Down Options	123
5.3.6.2	Intel® ACBS Signal Configurations	123
5.4	LPC Bridge (w/ System and Management Functions) (D31:F0)	124
5.4.1	LPC Interface	124
5.4.1.1	LPC Cycle Types	125
5.4.1.2	Start Field Definition	125
5.4.1.3	Cycle Type / Direction (CYCTYPE + DIR)	126
5.4.1.4	Size	126
5.4.1.5	SYNC	127
5.4.1.6	SYNC Time-Out	127
5.4.1.7	SYNC Error Indication	127
5.4.1.8	LFRAME# Usage	127
5.4.1.9	I/O Cycles	128
5.4.1.10	Bus Master Cycles	128
5.4.1.11	LPC Power Management	128
5.4.1.12	Configuration and Intel® ICH8 Implications	128
5.5	DMA Operation (D31:F0)	129
5.5.1	Channel Priority	129
5.5.1.1	Fixed Priority	130
5.5.1.2	Rotating Priority	130
5.5.2	Address Compatibility Mode	130
5.5.3	Summary of DMA Transfer Sizes	131
5.5.3.1	Address Shifting When Programmed for 16-Bit I/O Count by Words	131
5.5.4	Autoinitialize	131
5.5.5	Software Commands	132



5.6	LPC DMA .....	132
5.6.1	Asserting DMA Requests .....	132
5.6.2	Abandoning DMA Requests .....	133
5.6.3	General Flow of DMA Transfers .....	133
5.6.4	Terminal Count .....	133
5.6.5	Verify Mode .....	134
5.6.6	DMA Request Deassertion .....	134
5.6.7	SYNC Field / LDRQ# Rules .....	135
5.7	8254 Timers (D31:F0) .....	135
5.7.1	Timer Programming .....	136
5.7.2	Reading from the Interval Timer .....	137
5.7.2.1	Simple Read .....	137
5.7.2.2	Counter Latch Command .....	137
5.7.2.3	Read Back Command .....	138
5.8	8259 Interrupt Controllers (PIC) (D31:F0) .....	139
5.8.1	Interrupt Handling .....	140
5.8.1.1	Generating Interrupts .....	140
5.8.1.2	Acknowledging Interrupts .....	140
5.8.1.3	Hardware/Software Interrupt Sequence .....	141
5.8.2	Initialization Command Words (ICWx) .....	141
5.8.2.1	ICW1 .....	141
5.8.2.2	ICW2 .....	142
5.8.2.3	ICW3 .....	142
5.8.2.4	ICW4 .....	142
5.8.3	Operation Command Words (OCW) .....	142
5.8.4	Modes of Operation .....	143
5.8.4.1	Fully Nested Mode .....	143
5.8.4.2	Special Fully-Nested Mode .....	143
5.8.4.3	Automatic Rotation Mode (Equal Priority Devices) .....	143
5.8.4.4	Specific Rotation Mode (Specific Priority) .....	143
5.8.4.5	Poll Mode .....	144
5.8.4.6	Cascade Mode .....	144
5.8.4.7	Edge and Level Triggered Mode .....	144
5.8.4.8	End of Interrupt (EOI) Operations .....	144
5.8.4.9	Normal End of Interrupt .....	144
5.8.4.10	Automatic End of Interrupt Mode .....	145
5.8.5	Masking Interrupts .....	145
5.8.5.1	Masking on an Individual Interrupt Request .....	145
5.8.5.2	Special Mask Mode .....	145
5.8.6	Steering PCI Interrupts .....	145
5.9	Advanced Programmable Interrupt Controller (APIC) (D31:F0) .....	146
5.9.1	Interrupt Handling .....	146
5.9.2	Interrupt Mapping .....	146
5.9.3	PCI / PCI Express* Message-Based Interrupts .....	147
5.9.4	Front Side Bus Interrupt Delivery .....	147
5.9.4.1	Edge-Triggered Operation .....	148
5.9.4.2	Level-Triggered Operation .....	148
5.9.4.3	Registers Associated with Front Side Bus Interrupt Delivery .....	148
5.9.4.4	Interrupt Message Format .....	148
5.10	Serial Interrupt (D31:F0) .....	149
5.10.1	Start Frame .....	150
5.10.2	Data Frames .....	150
5.10.3	Stop Frame .....	150
5.10.4	Specific Interrupts Not Supported via SERIRQ .....	151
5.10.5	Data Frame Format .....	151



5.11	Real Time Clock (D31:F0)	152
5.11.1	Update Cycles	152
5.11.2	Interrupts	153
5.11.3	Lockable RAM Ranges	153
5.11.4	Century Rollover	153
5.11.5	Clearing Battery-Backed RTC RAM	153
5.12	Processor Interface (D31:F0)	155
5.12.1	Processor Interface Signals	155
5.12.1.1	A20M# (Mask A20)	155
5.12.1.2	INIT# (Initialization)	156
5.12.1.3	FERR#/IGNNE# (Numeric Coprocessor Error/ Ignore Numeric Error)	157
5.12.1.4	NMI (Non-Maskable Interrupt)	157
5.12.1.5	Stop Clock Request and CPU Sleep (STPCLK# and CPUSLP#)	157
5.12.1.6	CPU Power Good (CPUPWRGOOD)	157
5.12.1.7	Deeper Sleep (DPSLP#) (Mobile Only)	158
5.12.2	Dual-Processor Issues (Desktop Only)	158
5.12.2.1	Signal Differences	158
5.12.2.2	Power Management	158
5.13	Power Management (D31:F0)	159
5.13.1	Features	159
5.13.2	Intel® ICH8 and System Power States	160
5.13.3	System Power Planes	162
5.13.4	SMI#/SCI Generation	162
5.13.4.1	PCI Express* SCI	165
5.13.4.2	PCI Express* Hot-Plug	165
5.13.5	Dynamic Processor Clock Control	165
5.13.5.1	Slow C4 Exit (Mobile Only)	166
5.13.5.2	Transition Rules among S0/Cx and Throttling States	167
5.13.5.3	Deferred C3/C4 (Mobile Only)	167
5.13.5.4	POPOP (Auto C3/C4 to C2) (Mobile Only)	167
5.13.5.5	POPDOWN (Auto C2 to C3/C4) (Mobile Only)	168
5.13.6	Dynamic PCI Clock Control (Mobile Only)	168
5.13.6.1	Conditions for Checking the PCI Clock	168
5.13.6.2	Conditions for Maintaining the PCI Clock	168
5.13.6.3	Conditions for Stopping the PCI Clock	168
5.13.6.4	Conditions for Re-Starting the PCI Clock	169
5.13.6.5	LPC Devices and CLKRUN#	169
5.13.7	Sleep States	169
5.13.7.1	Sleep State Overview	169
5.13.7.2	Initiating Sleep State	169
5.13.7.3	Exiting Sleep States	170
5.13.7.4	PCI Express* WAKE# Signal and PME Event Message	172
5.13.7.5	Sx-G3-Sx, Handling Power Failures	172
5.13.8	Thermal Management	173
5.13.8.1	THRM# Signal	173
5.13.8.2	Software Initiated Passive Cooling	173
5.13.8.3	THRM# Override Software Bit	173
5.13.8.4	Active Cooling	173
5.13.9	Event Input Signals and Their Usage	174
5.13.9.1	PWRBTN# (Power Button)	174
5.13.9.2	RI# (Ring Indicator)	175
5.13.9.3	PME# (PCI Power Management Event)	175
5.13.9.4	SYS_RESET# Signal	175
5.13.9.5	THRMTRIP# Signal	176
5.13.9.6	BMBUSY# (Mobile Only)	176



5.13.10	ALT Access Mode	177
5.13.10.1	Write Only Registers with Read Paths in ALT Access Mode	177
5.13.10.2	PIC Reserved Bits	179
5.13.10.3	Read Only Registers with Write Paths in ALT Access Mode	180
5.13.11	System Power Supplies, Planes, and Signals	180
5.13.11.1	Power Plane Control with SLP_S3#, SLP_S4#, SLP_S5# and SLP_M#	180
5.13.11.2	SLP_S4# and Suspend-To-RAM Sequencing	181
5.13.11.3	PWROK Signal	181
5.13.11.4	CPUPWRGD Signal	181
5.13.11.5	VRMPWRGD Signal	181
5.13.11.6	BATLOW# (Battery Low) (Mobile Only)	182
5.13.11.7	Controlling Leakage and Power Consumption during Low-Power States	182
5.13.12	Clock Generators	182
5.13.12.1	Clock Control Signals from Intel® ICH8 to Clock Synthesizer (Mobile Only)	183
5.13.13	Legacy Power Management Theory of Operation	183
5.13.13.1	APM Power Management (Desktop Only)	183
5.13.13.2	Mobile APM Power Management (Mobile Only)	183
5.14	System Management (D31:F0)	184
5.14.1	Theory of Operation	184
5.14.1.1	Detecting a System Lockup	184
5.14.1.2	Handling an Intruder	184
5.14.1.3	Detecting Improper Firmware Hub Programming	185
5.14.2	TCO Modes	185
5.14.2.1	TCO Legacy/Compatible Mode	185
5.14.2.2	Advanced TCO Mode	187
5.14.2.3	Advanced TCO BMC Mode	187
5.15	IDE Controller (D31:F1) (Mobile Only)	189
5.15.1	PIO Transfers	189
5.15.1.1	PIO IDE Timing Modes	189
5.15.1.2	IORDY Masking	190
5.15.1.3	PIO 32-Bit IDE Data Port Accesses	190
5.15.1.4	PIO IDE Data Port Prefetching and Posting	190
5.15.2	Bus Master Function	191
5.15.2.1	Physical Region Descriptor Format	191
5.15.2.2	Bus Master IDE Timings	192
5.15.2.3	Interrupts	192
5.15.2.4	Bus Master IDE Operation	192
5.15.2.5	Error Conditions	193
5.15.3	Ultra ATA/100/66/33 Protocol	194
5.15.3.1	Operation	194
5.15.4	Ultra ATA/33/66/100 Timing	195
5.15.5	ATA Swap Bay	195
5.15.6	SMI Trapping	195
5.16	SATA Host Controller (D31:F2, F5)	196
5.16.1	Theory of Operation	197
5.16.1.1	Standard ATA Emulation	197
5.16.1.2	48-Bit LBA Operation	197
5.16.2	SATA Swap Bay Support	198
5.16.3	Intel® Matrix Storage Technology Configuration (Intel® ICH8R, ICH8DH, ICH8DO, and ICH8M-E Only)	198
5.16.3.1	Intel® Matrix Storage Manager RAID Option ROM	199
5.16.4	Power Management Operation	199
5.16.4.1	Power State Mappings	199
5.16.4.2	Power State Transitions	200



5.16.4.3	SMI Trapping (APM)	201
5.16.5	SATA LED	201
5.16.6	AHCI Operation	201
5.16.7	Serial ATA Reference Clock Low Power Request (SATACLKREQ#)	202
5.16.8	SGPIO Signals	202
5.16.9	External SATA (Intel® ICH8R, ICH8DH, and ICH8DO Only)	202
5.17	High Precision Event Timers	203
5.17.1	Timer Accuracy	203
5.17.2	Interrupt Mapping	203
5.17.3	Periodic vs. Non-Periodic Modes	204
5.17.4	Enabling the Timers	204
5.17.5	Interrupt Levels	205
5.17.6	Handling Interrupts	205
5.17.7	Issues Related to 64-Bit Timers with 32-Bit Processors	205
5.18	USB UHCI Host Controllers (D29:F0, F1, F2 and D26:F0, F1)	206
5.18.1	Data Structures in Main Memory	206
5.18.2	Data Transfers to/from Main Memory	206
5.18.3	Data Encoding and Bit Stuffing	206
5.18.4	Bus Protocol	206
5.18.4.1	Bit Ordering	206
5.18.4.2	SYNC Field	206
5.18.4.3	Packet Field Formats	206
5.18.4.4	Address Fields	207
5.18.4.5	Frame Number Field	207
5.18.4.6	Data Field	207
5.18.4.7	Cyclic Redundancy Check (CRC)	207
5.18.5	Packet Formats	207
5.18.6	USB Interrupts	207
5.18.6.1	Transaction-Based Interrupts	207
5.18.6.2	Non-Transaction Based Interrupts	209
5.18.7	USB Power Management	210
5.18.8	USB Legacy Keyboard Operation	210
5.19	USB EHCI Host Controllers (D29:F7 and D26:F7)	213
5.19.1	EHC Initialization	213
5.19.1.1	BIOS Initialization	213
5.19.1.2	Driver Initialization	213
5.19.1.3	EHC Resets	214
5.19.2	Data Structures in Main Memory	214
5.19.3	USB 2.0 Enhanced Host Controller DMA	214
5.19.4	Data Encoding and Bit Stuffing	214
5.19.5	Packet Formats	214
5.19.6	USB 2.0 Interrupts and Error Conditions	215
5.19.6.1	Aborts on USB 2.0-Initiated Memory Reads	215
5.19.7	USB 2.0 Power Management	216
5.19.7.1	USB Pre-Fetch Pause Feature	216
5.19.7.2	Suspend Feature	216
5.19.7.3	ACPI Device States	216
5.19.7.4	ACPI System States	217
5.19.7.5	Mobile Considerations	217
5.19.8	Interaction with UHCI Host Controllers	217
5.19.8.1	Port-Routing Logic	217
5.19.8.2	Device Connects	218
5.19.8.3	Device Disconnects	219
5.19.8.4	Effect of Resets on Port-Routing Logic	219
5.19.9	USB 2.0 Legacy Keyboard Operation	219
5.19.10	USB 2.0 Based Debug Port	220





5.19.10.1	Theory of Operation .....	220
5.20	SMBus Controller (D31:F3) .....	225
5.20.1	Host Controller .....	225
5.20.1.1	Command Protocols .....	226
5.20.2	Bus Arbitration .....	229
5.20.3	Bus Timing .....	230
5.20.3.1	Clock Stretching .....	230
5.20.3.2	Bus Time Out (Intel® ICH8 as SMBus Master) .....	230
5.20.4	Interrupts / SMI# .....	230
5.20.5	SMBALERT# .....	232
5.20.6	SMBus CRC Generation and Checking .....	232
5.20.7	SMBus Slave Interface .....	232
5.20.7.1	Format of Slave Write Cycle .....	233
5.20.7.2	Format of Read Command .....	235
5.20.7.3	Format of Host Notify Command .....	237
5.21	Intel® High Definition Audio Overview .....	238
5.21.1	Intel® High Definition Audio Docking (Mobile Only) .....	238
5.21.1.1	Dock Sequence .....	238
5.21.1.2	Exiting D3/CRST# when Docked .....	239
5.21.1.3	Cold Boot/Resume from S3 When Docked .....	240
5.21.1.4	Undock Sequence .....	240
5.21.1.5	Interaction Between Dock/Undock and Power Management States .....	241
5.21.1.6	Relationship between HDA_DOCK_RST# and HDA_RST# .....	241
5.22	Intel® Active Management Technology (Intel® AMT) (Intel® ICH8DO and ICH8M-E Only) .....	242
5.22.1	Intel® AMT Features .....	242
5.22.2	Intel® AMT Requirements .....	242
5.23	Serial Peripheral Interface (SPI) .....	243
5.23.1	SPI Supported Feature Overview .....	243
5.23.1.1	Flash Descriptor .....	244
5.23.1.2	Flash Access .....	245
5.23.1.3	Program Register Software Sequencing .....	245
5.23.1.4	Direct Access Security .....	245
5.23.1.5	Register Access Security .....	245
5.23.2	SPI Device Compatibility Requirements .....	246
5.23.2.1	Device Requirements for System BIOS Storage Only .....	246
5.23.2.2	Device Requirements for Intel® AMT, ASF and AFSC Firmware .....	246
5.23.2.3	Device Requirements for GbE .....	247
5.23.3	Serial Flash Command Set .....	247
5.23.3.1	Required Command Set for Interoperability .....	247
5.23.3.2	Recommended Command Set and Opcodes .....	248
5.23.3.3	JEDEC Device Identification .....	248
5.23.3.4	Multiple Page Write Usage Model .....	248
5.24	Intel® Quiet System Technology (Desktop Only) .....	249
5.24.1	PWM Outputs .....	249
5.24.2	TACH Inputs .....	249
5.25	Thermal Sensors .....	249
5.26	Intel® Quick Resume Technology (Intel® ICH8DH Only) .....	250
5.26.1	5.26.1 Visual Off .....	250
5.26.2	5.26.2 CE-like On/Off .....	250
5.26.3	Intel® Quick Resume Technology Signals .....	250
5.26.4	Power Button Sequence .....	251
5.27	Feature Capability Mechanism .....	251
5.28	Serial POST Codes Over GPIO .....	252
5.28.1	Theory of operation .....	252



5.28.2	Serial Message Format .....	253
<b>6</b>	<b>Register and Memory Mapping .....</b>	<b>255</b>
6.1	PCI Devices and Functions .....	255
6.2	PCI Configuration Map .....	257
6.3	I/O Map .....	257
6.3.1	Fixed I/O Address Ranges .....	257
6.3.2	Variable I/O Decode Ranges .....	260
6.4	Memory Map .....	261
6.4.1	Boot-Block Update Scheme .....	263
<b>7</b>	<b>Chipset Configuration Registers .....</b>	<b>265</b>
7.1	Chipset Configuration Registers (Memory Space) .....	265
7.1.1	VCH—Virtual Channel Capability Header Register .....	268
7.1.2	VCAP1—Virtual Channel Capability #1 Register .....	268
7.1.3	VCAP2—Virtual Channel Capability #2 Register .....	268
7.1.4	PVC—Port Virtual Channel Control Register .....	269
7.1.5	PVS—Port Virtual Channel Status Register .....	269
7.1.6	VOCAP—Virtual Channel 0 Resource Capability Register .....	269
7.1.7	VOCTL—Virtual Channel 0 Resource Control Register .....	270
7.1.8	VOSTS—Virtual Channel 0 Resource Status Register .....	270
7.1.9	V1CAP—Virtual Channel 1 Resource Capability Register .....	271
7.1.10	V1CTL—Virtual Channel 1 Resource Control Register .....	271
7.1.11	V1STS—Virtual Channel 1 Resource Status Register .....	272
7.1.12	PAT—Port Arbitration Table .....	272
7.1.13	CIR1—Chipset Initialization Register 1 .....	272
7.1.14	RCTCL—Root Complex Topology Capabilities List Register .....	273
7.1.15	ESD—Element Self Description Register .....	273
7.1.16	ULD—Upstream Link Descriptor Register .....	273
7.1.17	ULBA—Upstream Link Base Address Register .....	274
7.1.18	RP1D—Root Port 1 Descriptor Register .....	274
7.1.19	RP1BA—Root Port 1 Base Address Register .....	274
7.1.20	RP2D—Root Port 2 Descriptor Register .....	275
7.1.21	RP2BA—Root Port 2 Base Address Register .....	275
7.1.22	RP3D—Root Port 3 Descriptor Register .....	275
7.1.23	RP3BA—Root Port 3 Base Address Register .....	276
7.1.24	RP4D—Root Port 4 Descriptor Register .....	276
7.1.25	RP4BA—Root Port 4 Base Address Register .....	276
7.1.26	HDD—Intel® High Definition Audio Descriptor Register .....	277
7.1.27	HDBA—Intel® High Definition Audio Base Address Register .....	277
7.1.28	RP5D—Root Port 5 Descriptor Register .....	277
7.1.29	RP5BA—Root Port 5 Base Address Register .....	278
7.1.30	RP6D—Root Port 6 Descriptor Register .....	278
7.1.31	RP6BA—Root Port 6 Base Address Register .....	278
7.1.32	ILCL—Internal Link Capabilities List Register .....	279
7.1.33	LCAP—Link Capabilities Register .....	279
7.1.34	LCTL—Link Control Register .....	280
7.1.35	LSTS—Link Status Register .....	280
7.1.36	CIR2 — Chipset Initialization Register 2 .....	280
7.1.37	CIR3 — Chipset Initialization Register 3 .....	281
7.1.38	CIR4 — Chipset Initialization Register 4 .....	281
7.1.39	BCR — Backbone Configuration Register .....	281
7.1.40	RPC—Root Port Configuration Register .....	282
7.1.41	DMIC—DMI Control Register .....	282
7.1.42	RPFN—Root Port Function Number for PCI Express* Root Ports .....	283
7.1.43	CIR5—Chipset Initialization Register 5 .....	284



7.1.44	TRSR—Trap Status Register .....	284
7.1.45	TRCR—Trapped Cycle Register .....	284
7.1.46	TWDR—Trapped Write Data Register .....	285
7.1.47	IOTRn — I/O Trap Register (0–3) .....	285
7.1.48	DMC—DMI Miscellaneous Control Register (Mobile Only) .....	286
7.1.49	CIR6—Chipset Initialization Register 6 (Mobile Only) .....	286
7.1.50	CIR7—Chipset Initialization Register 7 .....	286
7.1.51	TCTL—TCO Configuration Register .....	287
7.1.52	D31IP—Device 31 Interrupt Pin Register.....	288
7.1.53	D30IP—Device 30 Interrupt Pin Register.....	289
7.1.54	D29IP—Device 29 Interrupt Pin Register.....	289
7.1.55	D28IP—Device 28 Interrupt Pin Register.....	290
7.1.56	D27IP—Device 27 Interrupt Pin Register.....	291
7.1.57	D26IP—Device 26 Interrupt Pin Register.....	291
7.1.58	D25IP—Device 25 Interrupt Pin Register.....	292
7.1.59	D31IR—Device 31 Interrupt Route Register .....	292
7.1.60	D30IR—Device 30 Interrupt Route Register .....	293
7.1.61	D29IR—Device 29 Interrupt Route Register .....	293
7.1.62	D28IR—Device 28 Interrupt Route Register .....	295
7.1.63	D27IR—Device 27 Interrupt Route Register .....	296
7.1.64	D26IR—Device 26 Interrupt Route Register .....	297
7.1.65	D25IR—Device 25 Interrupt Route Register .....	298
7.1.66	OIC—Other Interrupt Control Register .....	299
7.1.67	RC—RTC Configuration Register .....	299
7.1.68	HPTC—High Precision Timer Configuration Register .....	300
7.1.69	GCS—General Control and Status Register.....	301
7.1.70	BUC—Backed Up Control Register .....	303
7.1.71	FD—Function Disable Register .....	303
7.1.72	CG—Clock Gating (Mobile Only).....	306
7.1.73	FDSW—Function Disable SUS Well .....	307
7.1.74	CIR8—Chipset Initialization Register 8.....	308
7.1.75	CIR9—Chipset Initialization Register 9.....	308
<b>8</b>	<b>Gigabit LAN Configuration Registers .....</b>	<b>309</b>
8.1	Gigabit LAN Configuration Registers .....	309
	(Gigabit LAN — D25:F0) .....	309
8.1.1	VID—Vendor Identification Register (Gigabit LAN—D25:F0) .....	310
8.1.2	DID—Device Identification Register (Gigabit LAN—D25:F0) .....	310
8.1.3	PCICMD—PCI Command Register (Gigabit LAN—D25:F0) .....	311
8.1.4	PCISTS—PCI Status Register (Gigabit LAN—D25:F0) .....	312
8.1.5	RID—Revision Identification Register (Gigabit LAN—D25:F0) .....	313
8.1.6	CC—Class Code Register (Gigabit LAN—D25:F0) .....	313
8.1.7	CLS—Cache Line Size Register (Gigabit LAN—D25:F0) .....	313
8.1.8	PLT—Primary Latency Timer Register (Gigabit LAN—D25:F0) .....	313
8.1.9	HT—Header Type Register (Gigabit LAN—D25:F0) .....	313
8.1.10	MBARA—Memory Base Address Register A (Gigabit LAN—D25:F0) .....	314



8.1.11	MBARB—Memory Base Address Register B (Gigabit LAN—D25:F0) .....	314
8.1.12	MBARC—Memory Base Address Register C (Gigabit LAN—D25:F0) .....	315
8.1.13	SID—Subsystem ID Register (Gigabit LAN—D25:F0) .....	315
8.1.14	SVID—Subsystem Vendor ID Register (Gigabit LAN—D25:F0) .....	315
8.1.15	ERBA—Expansion ROM Base Address Register (Gigabit LAN—D25:F0) .....	316
8.1.16	CAPP—Capabilities List Pointer Register (Gigabit LAN—D25:F0) .....	316
8.1.17	INTR—Interrupt Information Register (Gigabit LAN—D25:F0) .....	316
8.1.18	MLMG—Maximum Latency/Minimum Grant Register (Gigabit LAN—D25:F0) .....	316
8.1.19	CLIST 1—Capabilities List Register 1 (Gigabit LAN—D25:F0) .....	317
8.1.20	PMC—PCI Power Management Capabilities Register (Gigabit LAN—D25:F0) .....	317
8.1.21	PMCS—PCI Power Management Control and Status Register (Gigabit LAN—D25:F0) .....	318
8.1.22	DR—Data Register (Gigabit LAN—D25:F0) .....	318
8.1.23	CLIST 2—Capabilities List Register 2 (Gigabit LAN—D25:F0) .....	319
8.1.24	MCTL—Message Control Register (Gigabit LAN—D25:F0) .....	319
8.1.25	MADDL—Message Address Low Register (Gigabit LAN—D25:F0) .....	319
8.1.26	MADDH—Message Address High Register (Gigabit LAN—D25:F0) .....	320
8.1.27	MDAT—Message Data Register (Gigabit LAN—D25:F0) .....	320
8.2	GBARO—Gigabit LAN Base Address Register 0 Registers .....	321
8.2.1	LDCR1—LAN Device Control Register 1 (Gigabit LAN Memory Mapped Base Address Register) .....	321
8.2.2	LDCR2—LAN Device Control Register 2 (Gigabit LAN Memory Mapped Base Address Register) .....	321
8.2.3	LDR1—LAN Device Initialization Register 1 (Gigabit LAN Memory Mapped Base Address Register) .....	321
8.2.4	EXTCNF_CTRL—Extended Configuration Control Register (Gigabit LAN Memory Mapped Base Address Register) .....	322
8.2.5	LDR2—LAN Device Initialization Register 2 (Gigabit LAN Memory Mapped Base Address Register) .....	322
<b>9</b>	<b>LPC Interface Bridge Registers (D31:F0) .....</b>	<b>323</b>
9.1	PCI Configuration Registers (LPC I/F—D31:F0) .....	323
9.1.1	VID—Vendor Identification Register (LPC I/F—D31:F0) .....	324
9.1.2	DID—Device Identification Register (LPC I/F—D31:F0) .....	324
9.1.3	PCICMD—PCI COMMAND Register (LPC I/F—D31:F0) .....	325
9.1.4	PCISTS—PCI Status Register (LPC I/F—D31:F0) .....	325
9.1.5	RID—Revision Identification Register (LPC I/F—D31:F0) .....	326
9.1.6	PI—Programming Interface Register (LPC I/F—D31:F0) .....	326
9.1.7	SCC—Sub Class Code Register (LPC I/F—D31:F0) .....	327
9.1.8	BCC—Base Class Code Register (LPC I/F—D31:F0) .....	327
9.1.9	PLT—Primary Latency Timer Register (LPC I/F—D31:F0) .....	327



9.1.10	HEADTYP—Header Type Register (LPC I/F—D31:F0)	327
9.1.11	SS—Sub System Identifiers Register (LPC I/F—D31:F0)	328
9.1.12	PMBASE—ACPI Base Address Register (LPC I/F—D31:F0)	328
9.1.13	ACPI_CNTL—ACPI Control Register (LPC I/F — D31:F0)	329
9.1.14	GPIOBASE—GPIO Base Address Register (LPC I/F — D31:F0)	329
9.1.15	GC—GPIO Control Register (LPC I/F — D31:F0)	330
9.1.16	PIRQ[n]_ROUT—PIRQ[A,B,C,D] Routing Control Register (LPC I/F—D31:F0)	330
9.1.17	SIRQ_CNTL—Serial IRQ Control Register (LPC I/F—D31:F0)	331
9.1.18	PIRQ[n]_ROUT—PIRQ[E,F,G,H] Routing Control Register (LPC I/F—D31:F0)	332
9.1.19	LPC_I/O_DEC—I/O Decode Ranges Register (LPC I/F—D31:F0)	333
9.1.20	LPC_EN—LPC I/F Enables Register (LPC I/F—D31:F0)	334
9.1.21	GEN1_DEC—LPC I/F Generic Decode Range 1 Register (LPC I/F—D31:F0)	335
9.1.22	GEN2_DEC—LPC I/F Generic Decode Range 2 Register (LPC I/F—D31:F0)	335
9.1.23	GEN3_DEC—LPC I/F Generic Decode Range 3 Register (LPC I/F—D31:F0)	336
9.1.24	GEN4_DEC—LPC I/F Generic Decode Range 4 Register (LPC I/F—D31:F0)	336
9.1.25	FWH_SEL1—Firmware Hub Select 1 Register (LPC I/F—D31:F0)	337
9.1.26	FWH_SEL2—Firmware Hub Select 2 Register (LPC I/F—D31:F0)	338
9.1.27	FWH_DEC_EN1—Firmware Hub Decode Enable Register (LPC I/F—D31:F0)	338
9.1.28	BIOS_CNTL—BIOS Control Register (LPC I/F—D31:F0)	341
9.1.29	FDCAP—Feature Detection Capability ID (LPC I/F—D31:F0)	341
9.1.30	FDLEN—Feature Detection Capability Length (LPC I/F—D31:F0)	342
9.1.31	FDVER—Feature Detection Version (LPC I/F—D31:F0)	342
9.1.32	FDVCT—Feature Vector (LPC I/F—D31:F0)	342
9.1.33	RCBA—Root Complex Base Address Register (LPC I/F—D31:F0)	343
9.2	DMA I/O Registers (LPC I/F—D31:F0)	344
9.2.1	DMABASE_CA—DMA Base and Current Address Registers (LPC I/F—D31:F0)	345
9.2.2	DMABASE_CC—DMA Base and Current Count Registers (LPC I/F—D31:F0)	346
9.2.3	DMAMEM_LP—DMA Memory Low Page Registers (LPC I/F—D31:F0)	346
9.2.4	DMACMD—DMA Command Register (LPC I/F—D31:F0)	347
9.2.5	DMASTA—DMA Status Register (LPC I/F—D31:F0)	347
9.2.6	DMA_WRSMSK—DMA Write Single Mask Register (LPC I/F—D31:F0)	348
9.2.7	DMACH_MODE—DMA Channel Mode Register (LPC I/F—D31:F0)	349
9.2.8	DMA Clear Byte Pointer Register (LPC I/F—D31:F0)	350
9.2.9	DMA Master Clear Register (LPC I/F—D31:F0)	350
9.2.10	DMA_CLMSK—DMA Clear Mask Register (LPC I/F—D31:F0)	351



9.2.11	DMA_WRMSK—DMA Write All Mask Register (LPC I/F—D31:F0) .....	351
9.3	Timer I/O Registers (LPC I/F—D31:F0) .....	352
9.3.1	TCW—Timer Control Word Register (LPC I/F—D31:F0) .....	353
9.3.2	SBYTE_FMT—Interval Timer Status Byte Format Register (LPC I/F—D31:F0) .....	355
9.3.3	Counter Access Ports Register (LPC I/F—D31:F0) .....	356
9.4	8259 Interrupt Controller (PIC) Registers (LPC I/F—D31:F0) .....	356
9.4.1	Interrupt Controller I/O MAP (LPC I/F—D31:F0) .....	356
9.4.2	ICW1—Initialization Command Word 1 Register (LPC I/F—D31:F0) .....	357
9.4.3	ICW2—Initialization Command Word 2 Register (LPC I/F—D31:F0) .....	358
9.4.4	ICW3—Master Controller Initialization Command Word 3 Register (LPC I/F—D31:F0) .....	358
9.4.5	ICW3—Slave Controller Initialization Command Word 3 Register (LPC I/F—D31:F0) .....	359
9.4.6	ICW4—Initialization Command Word 4 Register (LPC I/F—D31:F0) .....	359
9.4.7	OCW1—Operational Control Word 1 (Interrupt Mask) Register (LPC I/F—D31:F0) .....	360
9.4.8	OCW2—Operational Control Word 2 Register (LPC I/F—D31:F0) .....	360
9.4.9	OCW3—Operational Control Word 3 Register (LPC I/F—D31:F0) .....	361
9.4.10	ELCR1—Master Controller Edge/Level Triggered Register (LPC I/F—D31:F0) .....	362
9.4.11	ELCR2—Slave Controller Edge/Level Triggered Register (LPC I/F—D31:F0) .....	363
9.5	Advanced Programmable Interrupt Controller (APIC)(D31:F0).....	364
9.5.1	APIC Register Map (LPC I/F—D31:F0) .....	364
9.5.2	IND—Index Register (LPC I/F—D31:F0) .....	364
9.5.3	DAT—Data Register (LPC I/F—D31:F0) .....	365
9.5.4	EOIR—EOI Register (LPC I/F—D31:F0) .....	365
9.5.5	ID—Identification Register (LPC I/F—D31:F0) .....	366
9.5.6	VER—Version Register (LPC I/F—D31:F0) .....	366
9.5.7	REDIR_TBL—Redirection Table (LPC I/F—D31:F0) .....	367
9.6	Real Time Clock Registers (LPC I/F—D31:F0).....	369
9.6.1	I/O Register Address Map (LPC I/F—D31:F0) .....	369
9.6.2	Indexed Registers (LPC I/F—D31:F0) .....	370
9.6.2.1	RTC_REGA—Register A (LPC I/F—D31:F0) .....	371
9.6.2.2	RTC_REGB—Register B (General Configuration) (LPC I/F—D31:F0) .....	372
9.6.2.3	RTC_REGC—Register C (Flag Register) (LPC I/F—D31:F0) .....	373
9.6.2.4	RTC_REGD—Register D (Flag Register) (LPC I/F—D31:F0) .....	373
9.7	Processor Interface Registers (LPC I/F—D31:F0) .....	374
9.7.1	NMI_SC—NMI Status and Control Register (LPC I/F—D31:F0) .....	374
9.7.2	NMI_EN—NMI Enable (and Real Time Clock Index) Register (LPC I/F—D31:F0) .....	375
9.7.3	PORT92—Fast A20 and Init Register (LPC I/F—D31:F0) .....	375
9.7.4	COPROC_ERR—Coprocessor Error Register (LPC I/F—D31:F0) .....	376
9.7.5	RST_CNT—Reset Control Register (LPC I/F—D31:F0).....	376

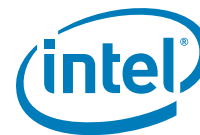


9.8	Power Management Registers (PM—D31:F0) .....	377
9.8.1	Power Management PCI Configuration Registers (PM—D31:F0) .....	377
9.8.1.1	GEN_PMCON_1—General PM Configuration 1 Register (PM—D31:F0) .....	378
9.8.1.2	GEN_PMCON_2—General PM Configuration 2 Register (PM—D31:F0) .....	380
9.8.1.3	GEN_PMCON_3—General PM Configuration 3 Register (PM—D31:F0) .....	381
9.8.1.4	GEN_PMCON_LOCK—General Power Management Configuration Lock Register383	
9.8.1.5	Cx-STATE_CNF—Cx State Configuration Register (PM—D31:F0) (Mobile Only) .....	384
9.8.1.6	C4-TIMING_CNT—C4 Timing Control Register (PM—D31:F0) (Mobile Only) .....	385
9.8.1.7	BM_BREAK_EN Register (PM—D31:F0) (Mobile Only) .....	386
9.8.1.8	PMIR—Power Management Initialization Register.....	387
9.8.1.9	QRT_STS (PM—D31:F0): Quick Resume Technology Status Register (Intel® ICH8DH Only)387	
9.8.1.10	QRT_CNT1 (PM—D31:F0): Quick Resume Technology Control 1 Register (Intel® ICH8DH Only)388	
9.8.1.11	QRT_CNT2 (PM—D31:F0): Quick Resume Technology Control 2 Register (Intel® ICH8DH Only)389	
9.8.1.12	GPIO_ROUT—GPIO Routing Control Register (PM—D31:F0) .....	389
9.8.2	APM I/O Decode.....	390
9.8.2.1	APM_CNT—Advanced Power Management Control Port Register.....	390
9.8.2.2	APM_STS—Advanced Power Management Status Port Register.....	390
9.8.3	Power Management I/O Registers.....	391
9.8.3.1	PM1_STS—Power Management 1 Status Register .....	393
9.8.3.2	PM1_EN—Power Management 1 Enable Register .....	396
9.8.3.3	PM1_CNT—Power Management 1 Control .....	397
9.8.3.4	PM1_TMR—Power Management 1 Timer Register.....	398
9.8.3.5	PROC_CNT—Processor Control Register.....	398
9.8.3.6	LV2 — Level 2 Register (Mobile Only) .....	400
9.8.3.7	LV3—Level 3 Register (Mobile Only) .....	400
9.8.3.8	LV4—Level 4 Register (Mobile Only) .....	400
9.8.3.9	LV5—Level 5 Register (Mobile Only) .....	401
9.8.3.10	LV6—Level 6 Register (Mobile Only) .....	401
9.8.3.11	PM2_CNT—Power Management 2 Control (Mobile Only).....	401
9.8.3.12	GPE0_STS—General Purpose Event 0 Status Register .....	402
9.8.3.13	GPE0_EN—General Purpose Event 0 Enables Register .....	405
9.8.3.14	SMI_EN—SMI Control and Enable Register .....	407
9.8.3.15	SMI_STS—SMI Status Register .....	409
9.8.3.16	ALT_GP_SMI_EN—Alternate GPI SMI Enable Register .....	411
9.8.3.17	ALT_GP_SMI_STS—Alternate GPI SMI Status Register .....	412
9.8.3.18	GPE_CNTL— General Purpose Control Register.....	412
9.8.3.19	DEVACT_STS — Device Activity Status Register .....	413
9.8.3.20	SS_CNT— Intel SpeedStep® Technology Control Register (Mobile Only) .....	414
9.8.3.21	C3_RES— C3 Residency Register (Mobile Only) .....	414
9.8.3.22	C5_RES— C5 Residency Register (Mobile Only) .....	415
9.9	System Management TCO Registers (D31:F0) .....	416
9.9.1	TCO_RLD—TCO Timer Reload and Current Value Register .....	416
9.9.2	TCO_DAT_IN—TCO Data In Register .....	417
9.9.3	TCO_DAT_OUT—TCO Data Out Register .....	417
9.9.4	TCO1_STS—TCO1 Status Register .....	417



9.9.5	TCO2_STS—TCO2 Status Register	419
9.9.6	TCO1_CNT—TCO1 Control Register	420
9.9.7	TCO2_CNT—TCO2 Control Register	421
9.9.8	TCO_MESSAGE1 and TCO_MESSAGE2 Registers	421
9.9.9	TCO_WDCNT—TCO Watchdog Control Register	422
9.9.10	SW_IRQ_GEN—Software IRQ Generation Register	422
9.9.11	TCO_TMR—TCO Timer Initial Value Register	422
9.10	General Purpose I/O Registers (D31:F0)	423
9.10.1	GPIO_USE_SEL—GPIO Use Select Register	424
9.10.2	GP_IO_SEL—GPIO Input/Output Select Register	424
9.10.3	GP_LVL—GPIO Level for Input or Output Register	425
9.10.4	GPIO_USE_SEL Override Register (LOW)—GPIO Use Select Override Register Low	425
9.10.5	GPO_BLINK—GPO Blink Enable Register	426
9.10.6	GP_SER_BLINK[31:0]—GP Serial Blink	426
9.10.7	GP_SB_CMDSTS[31:0]—GP Serial Blink Command Status	427
9.10.8	GP_SB_DATA[31:0]—GP Serial Blink Data	427
9.10.9	GPI_INV—GPIO Signal Invert Register	428
9.10.10	GPIO_USE_SEL2—GPIO Use Select 2 Register[63:32]	428
9.10.11	GP_IO_SEL2—GPIO Input/Output Select 2 Register[63:32]	429
9.10.12	GP_LVL2—GPIO Level for Input or Output 2 Register[63:32]	429
9.10.13	GPIO_USE_SEL Override Register (HIGH)—GPIO Use Select Override Register High	430
10	<b>PCI-to-PCI Bridge Registers (D30:F0)</b>	431
10.1	PCI Configuration Registers (D30:F0)	431
10.1.1	VID—Vendor Identification Register (PCI-PCI—D30:F0)	432
10.1.2	DID—Device Identification Register (PCI-PCI—D30:F0)	432
10.1.3	PCICMD—PCI Command (PCI-PCI—D30:F0)	432
10.1.4	PSTS—PCI Status Register (PCI-PCI—D30:F0)	433
10.1.5	RID—Revision Identification Register (PCI-PCI—D30:F0)	435
10.1.6	CC—Class Code Register (PCI-PCI—D30:F0)	435
10.1.7	PMLT—Primary Master Latency Timer Register (PCI-PCI—D30:F0)	436
10.1.8	HEADTYP—Header Type Register (PCI-PCI—D30:F0)	436
10.1.9	BNUM—Bus Number Register (PCI-PCI—D30:F0)	436
10.1.10	SMLT—Secondary Master Latency Timer Register (PCI-PCI—D30:F0)	437
10.1.11	IOBASE_LIMIT—I/O Base and Limit Register (PCI-PCI—D30:F0)	437
10.1.12	SECSTS—Secondary Status Register (PCI-PCI—D30:F0)	438
10.1.13	MEMBASE_LIMIT—Memory Base and Limit Register (PCI-PCI—D30:F0)	439
10.1.14	PREF_MEM_BASE_LIMIT—Prefetchable Memory Base and Limit Register (PCI-PCI—D30:F0)	439
10.1.15	PMBU32—Prefetchable Memory Base Upper 32 Bits Register (PCI-PCI—D30:F0)	440
10.1.16	PMLU32—Prefetchable Memory Limit Upper 32 Bits Register (PCI-PCI—D30:F0)	440
10.1.17	CAPP—Capability List Pointer Register (PCI-PCI—D30:F0)	440
10.1.18	INTR—Interrupt Information Register (PCI-PCI—D30:F0)	440
10.1.19	BCTRL—Bridge Control Register (PCI-PCI—D30:F0)	441
10.1.20	SPDH—Secondary PCI Device Hiding Register (PCI-PCI—D30:F0)	442
10.1.21	DTC—Delayed Transaction Control Register (PCI-PCI—D30:F0)	443





10.1.22	BPS—Bridge Proprietary Status Register (PCI-PCI—D30:F0)	444
10.1.23	BPC—Bridge Policy Configuration Register (PCI-PCI—D30:F0)	445
10.1.24	SVCAP—Subsystem Vendor Capability Register (PCI-PCI—D30:F0)	446
10.1.25	SVID—Subsystem Vendor IDs Register (PCI-PCI—D30:F0)	446
<b>11</b>	<b>IDE Controller Registers (D31:F1) (Mobile Only)</b>	<b>447</b>
11.1	PCI Configuration Registers (IDE—D31:F1)	447
11.1.1	VID—Vendor Identification Register (IDE—D31:F1)	448
11.1.2	DID—Device Identification Register (IDE—D31:F1)	448
11.1.3	PCICMD—PCI Command Register (IDE—D31:F1)	449
11.1.4	PCISTS — PCI Status Register (IDE—D31:F1)	450
11.1.5	RID—Revision Identification Register (IDE—D31:F1)	451
11.1.6	PI—Programming Interface Register (IDE—D31:F1)	451
11.1.7	SCC—Sub Class Code Register (IDE—D31:F1)	451
11.1.8	BCC—Base Class Code Register (IDE—D31:F1)	452
11.1.9	CLS—Cache Line Size Register (IDE—D31:F1)	452
11.1.10	PMLT—Primary Master Latency Timer Register (IDE—D31:F1)	452
11.1.11	PCMD_BAR—Primary Command Block Base Address Register (IDE—D31:F1)	452
11.1.12	PCNL_BAR—Primary Control Block Base Address Register (IDE—D31:F1)	453
11.1.13	SCMD_BAR—Secondary Command Block Base Address Register (IDE D31:F1)	453
11.1.14	SCNL_BAR—Secondary Control Block Base Address Register (IDE D31:F1)	453
11.1.15	BM_BASE — Bus Master Base Address Register (IDE—D31:F1)	454
11.1.16	IDE_SVID — Subsystem Vendor Identification (IDE—D31:F1)	454
11.1.17	IDE_SID — Subsystem Identification Register (IDE—D31:F1)	454
11.1.18	INTR_LN—Interrupt Line Register (IDE—D31:F1)	455
11.1.19	INTR_PN—Interrupt Pin Register (IDE—D31:F1)	455
11.1.20	IDE_TIMP — IDE Primary Timing Register (IDE—D31:F1)	455
11.1.21	IDE_TIMS — IDE Secondary Timing Register (IDE—D31:F1)	457
11.1.22	SLV_IDETIM—Slave (Drive 1) IDE Timing Register (IDE—D31:F1)	457
11.1.23	SDMA_CNT—Synchronous DMA Control Register (IDE—D31:F1)	458
11.1.24	SDMA_TIM—Synchronous DMA Timing Register (IDE—D31:F1)	459
11.1.25	IDE_CONFIG—IDE I/O Configuration Register (IDE—D31:F1)	460
11.1.26	ATC—APM Trapping Control Register (IDE—D31:F1)	461
11.1.27	ATS—APM Trapping Status Register (IDE—D31:F1)	461
11.2	Bus Master IDE I/O Registers (IDE—D31:F1)	462
11.2.1	BMICP—Bus Master IDE Command Register (IDE—D31:F1)	462
11.2.2	BMISP—Bus Master IDE Status Register (IDE—D31:F1)	463
11.2.3	BMIDP—Bus Master IDE Descriptor Table Pointer Register (IDE—D31:F1)	463



<b>12</b>	<b>SATA Controller Registers (D31:F2)</b>	465
12.1	PCI Configuration Registers (SATA-D31:F2)	465
12.1.1	VID—Vendor Identification Register (SATA-D31:F2)	466
12.1.2	DID—Device Identification Register (SATA-D31:F2)	467
12.1.3	PCICMD—PCI Command Register (SATA-D31:F2)	467
12.1.4	PCISTS — PCI Status Register (SATA-D31:F2)	468
12.1.5	RID—Revision Identification Register (SATA-D31:F2)	468
12.1.6	PI—Programming Interface Register (SATA-D31:F2)	469
	12.1.6.1 When Sub Class Code Register (D31:F2:Offset 0Ah) = 01h	469
	12.1.6.2 When Sub Class Code Register (D31:F2:Offset 0Ah) = 04h	469
	12.1.6.3 When Sub Class Code Register (D31:F2:Offset 0Ah) = 06h	470
12.1.7	SCC—Sub Class Code Register (SATA-D31:F2)	470
12.1.8	BCC—Base Class Code Register (SATA-D31:F2SATA-D31:F2)	470
12.1.9	PMLT—Primary Master Latency Timer Register (SATA-D31:F2)	471
12.1.10	PCMD_BAR—Primary Command Block Base Address Register (SATA-D31:F2)	471
12.1.11	PCNL_BAR—Primary Control Block Base Address Register (SATA-D31:F2)	471
12.1.12	SCMD_BAR—Secondary Command Block Base Address Register (IDE D31:F1)	472
12.1.13	SCNL_BAR—Secondary Control Block Base Address Register (IDE D31:F1)	472
12.1.14	BAR — Legacy Bus Master Base Address Register (SATA-D31:F2)	473
12.1.15	ABAR/SIDPBA1 — AHCI Base Address Register/Serial ATA Index Data Pair Base Address (SATA-D31:F2)	473
	12.1.15.1When CC.SCC is not 01h	473
	12.1.15.2When CC.SCC is 01h	474
12.1.16	SVID—Subsystem Vendor Identification Register (SATA-D31:F2)	474
12.1.17	SID—Subsystem Identification Register (SATA-D31:F2)	474
12.1.18	CAP—Capabilities Pointer Register (SATA-D31:F2)	474
12.1.19	INT_LN—Interrupt Line Register (SATA-D31:F2)	475
12.1.20	INT_PN—Interrupt Pin Register (SATA-D31:F2)	475
12.1.21	IDE_TIM — IDE Timing Register (SATA-D31:F2)	475
12.1.22	SIDETIM—Slave IDE Timing Register (SATA-D31:F2)	477
12.1.23	SDMA_CNT—Synchronous DMA Control Register (SATA-D31:F2)	478
12.1.24	SDMA_TIM—Synchronous DMA Timing Register (SATA-D31:F2)	478
12.1.25	IDE_CONFIG—IDE I/O Configuration Register (SATA-D31:F2)	480
12.1.26	PID—PCI Power Management Capability Identification Register (SATA-D31:F2)	481
12.1.27	PC—PCI Power Management Capabilities Register (SATA-D31:F2)	482
12.1.28	PMCS—PCI Power Management Control and Status Register (SATA-D31:F2)	482
12.1.29	MSICI—Message Signaled Interrupt Capability Identification (SATA-D31:F2)	483
12.1.30	MSIMC—Message Signaled Interrupt Message Control (SATA-D31:F2)	483
12.1.31	MSIMA— Message Signaled Interrupt Message Address (SATA-D31:F2)	485
12.1.32	MSIMD—Message Signaled Interrupt Message Data (SATA-D31:F2)	485



12.1.33	MAP—Address Map Register (SATA–D31:F2)	486
12.1.34	PCS—Port Control and Status Register (SATA–D31:F2)	487
12.1.35	SCLKCG—SATA Clock Gating Control Register	489
12.1.36	SCLKGC—SATA Clock General Configuration Register	490
12.1.37	SIRI—SATA Indexed Registers Index Register	490
12.1.38	STRD—SATA Indexed Register Data Register	490
12.1.39	STTT1—SATA Indexed Registers Index 00h (SATA TX Termination Test Register 1)	492
12.1.40	SIR18—SATA Indexed Registers Index 18h (SATA Initialization Register 18h)	492
12.1.41	STME—SATA Indexed Registers Index 1Ch (SATA Test Mode Enable Register)	492
12.1.42	SIR28—SATA Indexed Registers Index 28h (SATA Initialization Register 28h)	493
12.1.43	SIR40—SATA Indexed Registers Index 40h (SATA Initialization Register 40h)	493
12.1.44	STTT2—SATA Indexed Registers Index 74h (SATA TX Termination Test Register 2)	493
12.1.45	SIR78—SATA Indexed Registers Index 78h (SATA Initialization Register 78h)	494
12.1.46	SIR84—SATA Indexed Registers Index 84h (SATA Initialization Register 84h)	494
12.1.47	SIR88—SATA Indexed Registers Index 88h (SATA Initialization Register 88h)	494
12.1.48	SIR8C—SATA Indexed Registers Index 8Ch (SATA Initialization Register 8Ch)	494
12.1.49	STTT3—SATA Indexed Registers Index 90h (SATA TX Termination Test Register 3)	495
12.1.50	SIR94—SATA Indexed Registers Index 94h (SATA Initialization Register 94h)	495
12.1.51	SIRA0—SATA Indexed Registers Index A0h (SATA Initialization Register A0h)	495
12.1.52	SIRA8—SATA Indexed Registers Index A8h (SATA Initialization Register A8h)	495
12.1.53	SIRAC—SATA Indexed Registers Index ACh (SATA Initialization Register ACh)	496
12.1.54	SATACR0—SATA Capability Register 0 (SATA–D31:F2)	496
12.1.55	SATACR1—SATA Capability Register 1 (SATA–D31:F2)	497
12.1.56	ATC—APM Trapping Control Register (SATA–D31:F2)	498
12.1.57	ATS—APM Trapping Status Register (SATA–D31:F2)	498
12.1.58	SP Scratch Pad Register (SATA–D31:F2)	498
12.1.59	BFCS—BIST FIS Control/Status Register (SATA–D31:F2)	499
12.1.60	BFTD1—BIST FIS Transmit Data1 Register (SATA–D31:F2)	501
12.1.61	BFTD2—BIST FIS Transmit Data2 Register (SATA–D31:F2)	501
12.2	Bus Master IDE I/O Registers (D31:F2)	502
12.2.1	BMIC[P,S]—Bus Master IDE Command Register (D31:F2)	503
12.2.2	BMIS[P,S]—Bus Master IDE Status Register (D31:F2)	504
12.2.3	BMID[P,S]—Bus Master IDE Descriptor Table Pointer Register (D31:F5)	505
12.2.3.1	PxSSTS—Serial ATA Status Register (D31:F5)	505
12.2.3.2	PxSCTL — Serial ATA Control Register (D31:F5)	507
12.2.3.3	PxSERR—Serial ATA Error Register (D31:F5)	508
12.2.4	AIR—AHCI Index Register (D31:F2)	509
12.2.5	AIDR—AHCI Index Data Register (D31:F2)	510
12.3	Serial ATA Index/Data Pair Superset Registers	510
12.3.1	SINDX—SATA Index Register (D31:F5)	510



12.3.2	SDATA—SATA Index Data Register (D31:F5)	511
12.4	AHCI Registers (D31:F2) (Intel® ICH8R, ICH8DH, ICH8DO, and ICH8M-E Only)	512
12.4.1	AHCI Generic Host Control Registers (D31:F2)	513
12.4.1.1	CAP—Host Capabilities Register (D31:F2)	513
12.4.1.2	GHC—Global ICH8 Control Register (D31:F2)	515
12.4.1.3	IS—Interrupt Status Register (D31:F2)	516
12.4.1.4	PI—Ports Implemented Register (D31:F2)	517
12.4.1.5	VS—AHCI Version (D31:F2)	518
12.4.1.6	CCC_CTL—Command Completion Coalescing Control Register (D31:F2)	518
12.4.1.7	CCC_Ports—Command Completion Coalescing Ports Register (D31:F2)	519
12.4.1.8	EM_LOC—Enclosure Management Location Register (D31:F2)	519
12.4.1.9	EM_CTL—Enclosure Management Control Register (D31:F2)	520
12.4.2	Port Registers (D31:F2)	521
12.4.2.1	PxCLB—Port [5:0] Command List Base Address Register (D31:F2)	524
12.4.2.2	PxCLBU—Port [5:0] Command List Base Address Upper 32-Bits Register (D31:F2)	524
12.4.2.3	PxFB—Port [5:0] FIS Base Address Register (D31:F2)	525
12.4.2.4	PxFBU—Port [5:0] FIS Base Address Upper 32-Bits Register (D31:F2)	525
12.4.2.5	PxIS—Port [5:0] Interrupt Status Register (D31:F2)	526
12.4.2.6	PxIE—Port [5:0] Interrupt Enable Register (D31:F2)	527
12.4.2.7	PxCMD—Port [5:0] Command Register (D31:F2)	529
12.4.2.8	PxTFD—Port [5:0] Task File Data Register (D31:F2)	532
12.4.2.9	PxSIG—Port [5:0] Signature Register (D31:F2)	532
12.4.2.10	PxSSTS—Port [5:0] Serial ATA Status Register (D31:F2)	533
12.4.2.11	PxSCTL — Port [5:0] Serial ATA Control Register (D31:F2)	534
12.4.2.12	PxSERR—Port [5:0] Serial ATA Error Register (D31:F2)	535
12.4.2.13	PxSACT—Port [5:0] Serial ATA Active (D31:F2)	537
12.4.2.14	PxCI—Port [5:0] Command Issue Register (D31:F2)	537
13	<b>SATA Controller Registers (D31:F5)</b>	539
13.1	PCI Configuration Registers (SATA—D31:F5)	539
13.1.1	VID—Vendor Identification Register (SATA—D31:F5)	540
13.1.2	DID—Device Identification Register (SATA—D31:F5)	541
13.1.3	PCICMD—PCI Command Register (SATA—D31:F5)	541
13.1.4	PCISTS — PCI Status Register (SATA—D31:F5)	542
13.1.5	RID—Revision Identification Register (SATA—D31:F5)	542
13.1.6	PI—Programming Interface Register (SATA—D31:F5)	543
13.1.7	SCC—Sub Class Code Register (SATA—D31:F5)	543
13.1.8	BCC—Base Class Code Register (SATA—D31:F5SATA—D31:F5)	543
13.1.9	PMLT—Primary Master Latency Timer Register (SATA—D31:F5)	543
13.1.10	PCMD_BAR—Primary Command Block Base Address Register (SATA—D31:F5)	544
13.1.11	PCNL_BAR—Primary Control Block Base Address Register (SATA—D31:F5)	544
13.1.12	SCMD_BAR—Secondary Command Block Base Address Register (IDE D31:F1)	544
13.1.13	SCNL_BAR—Secondary Control Block Base Address Register (IDE D31:F1)	545
13.1.14	BAR — Legacy Bus Master Base Address Register (SATA—D31:F5)	545



13.1.15	SIDPBA — SATA Index/Data Pair Base Address Register (SATA–D31:F5)	546
13.1.16	SVID—Subsystem Vendor Identification Register (SATA–D31:F5)	546
13.1.17	SID—Subsystem Identification Register (SATA–D31:F5)	546
13.1.18	CAP—Capabilities Pointer Register (SATA–D31:F5)	546
13.1.19	INT_LN—Interrupt Line Register (SATA–D31:F5)	547
13.1.20	INT_PN—Interrupt Pin Register (SATA–D31:F5)	547
13.1.21	IDE_TIM — IDE Timing Register (SATA–D31:F5)	547
13.1.22	D1TIM—Device 1 IDE Timing Register (SATA–D31:F5)	549
13.1.23	SDMA_CNT—Synchronous DMA Control Register (SATA–D31:F5)	549
13.1.24	SDMA_TIM—Synchronous DMA Timing Register (SATA–D31:F5)	550
13.1.25	IDE_CONFIG—IDE I/O Configuration Register (SATA–D31:F5)	551
13.1.26	PID—PCI Power Management Capability Identification Register (SATA–D31:F5)	552
13.1.27	PC—PCI Power Management Capabilities Register (SATA–D31:F5)	552
13.1.28	PMCS—PCI Power Management Control and Status Register (SATA–D31:F5)	553
13.1.29	MAP—Address Map Register (SATA–D31:F5)	553
13.1.30	PCS—Port Control and Status Register (SATA–D31:F5)	554
13.1.31	ATC—APM Trapping Control Register (SATA–D31:F5)	555
13.1.32	ATS—APM Trapping Status Register (SATA–D31:F5)	555
13.2	Bus Master IDE I/O Registers (D31:F5)	556
13.2.1	BMIC[P,S]—Bus Master IDE Command Register (D31:F5)	557
13.2.2	BMIS[P,S]—Bus Master IDE Status Register (D31:F5)	558
13.2.3	BMID[P,S]—Bus Master IDE Descriptor Table Pointer Register (D31:F5)	558
13.2.3.1	PxSSTS—Serial ATA Status Register (D31:F5)	559
13.2.3.2	PxSCTL — Serial ATA Control Register (D31:F5)	560
13.2.3.3	PxSERR—Serial ATA Error Register (D31:F5)	561
13.3	Serial ATA Index/Data Pair Superset Registers	563
13.3.1	SINDX—SATA Index Register (D31:F5)	563
13.3.2	SDATA—SATA Index Data Register (D31:F5)	563
<b>14</b>	<b>UHCI Controllers Registers</b>	<b>565</b>
14.1	PCI Configuration Registers (USB–D29:F0/F1/F2, D26:F0/F1)	565
14.1.1	VID—Vendor Identification Register (USB–D29:F0/F1/F2, D26:F0/F1)	566
14.1.2	DID—Device Identification Register (USB–D29:F0/F1/F2, D26:F0/F1)	566
14.1.3	PCICMD—PCI Command Register (USB–D29:F0/F1/F2, D26:F0/F1)	567
14.1.4	PCISTS—PCI Status Register (USB–D29:F0/F1/F2, D26:F0/F1)	568
14.1.5	RID—Revision Identification Register (USB–D29:F0/F1/F2, D26:F0/F1)	568
14.1.6	PI—Programming Interface Register (USB–D29:F0/F1/F2, D26:F0/F1)	569
14.1.7	SCC—Sub Class Code Register (USB–D29:F0/F1/F2, D26:F0/F1)	569
14.1.8	BCC—Base Class Code Register (USB–D29:F0/F1/F2, D26:F0/F1)	569



14.1.9	MLT—Master Latency Timer Register (USB—D29:F0/F1/F2, D26:F0/F1)	569
14.1.10	HEADTYP—Header Type Register (USB—D29:F0/F1/F2, D26:F0/F1)	570
14.1.11	BASE—Base Address Register (USB—D29:F0/F1/F2, D26:F0/F1)	570
14.1.12	SVID — Subsystem Vendor Identification Register (USB—D29:F0/F1/F2, D26:F0/F1)	570
14.1.13	SID — Subsystem Identification Register (USB—D29:F0/F1/F2/F3, D26:F0/F1)	571
14.1.14	INT_LN—Interrupt Line Register (USB—D29:F0/F1/F2, D26:F0/F1)	571
14.1.15	INT_PN—Interrupt Pin Register (USB—D29:F0/F1/F2/F3, D26:F0/F1)	571
14.1.16	USB_RELNUM—Serial Bus Release Number Register (USB—D29:F0/F1/F2, D26:F0/F1)	572
14.1.17	USB_LEGKEY—USB Legacy Keyboard/Mouse Control Register (USB—D29:F0/F1/F2, D26:F0/F1)	572
14.1.18	USB_RES—USB Resume Enable Register (USB—D29:F0/F1/F2, D26:F0/F1)	574
14.1.19	CWP—Core Well Policy Register (USB—D29:F0/F1/F2, D26:F0/F1)	574
14.2	USB I/O Registers	575
14.2.1	USBCMD—USB Command Register	576
14.2.2	USBSTS—USB Status Register	579
14.2.3	USBINTR—USB Interrupt Enable Register	580
14.2.4	FRNUM—Frame Number Register	580
14.2.5	FRBASEADD—Frame List Base Address Register	581
14.2.6	SOFMOD—Start of Frame Modify Register	581
14.2.7	PORTSC[0,1]—Port Status and Control Register	582
<b>15</b>	<b>EHCI Controller Registers (D29:F7, D26:F7)</b>	<b>585</b>
15.1	USB EHCI Configuration Registers (USB EHCI—D29:F7, D26:F7)	585
15.1.1	VID—Vendor Identification Register (USB EHCI—D29:F7, D26:F7)	586
15.1.2	DID—Device Identification Register (USB EHCI—D29:F7, D26:F7)	586
15.1.3	PCICMD—PCI Command Register (USB EHCI—D29:F7, D26:F7)	587
15.1.4	PCISTS—PCI Status Register (USB EHCI—D29:F7, D26:F7)	588
15.1.5	RID—Revision Identification Register (USB EHCI—D29:F7, D26:F7)	589
15.1.6	PI—Programming Interface Register (USB EHCI—D29:F7, D26:F7)	589
15.1.7	SCC—Sub Class Code Register (USB EHCI—D29:F7, D26:F7)	589
15.1.8	BCC—Base Class Code Register (USB EHCI—D29:F7, D26:F7)	589
15.1.9	PMLT—Primary Master Latency Timer Register (USB EHCI—D29:F7, D26:F7)	590
15.1.10	MEM_BASE—Memory Base Address Register (USB EHCI—D29:F7, D26:F7)	590
15.1.11	SVID—USB EHCI Subsystem Vendor ID Register (USB EHCI—D29:F7, D26:F7)	590



15.1.12	SID—USB EHCI Subsystem ID Register (USB EHCI—D29:F7, D26:F7)	591
15.1.13	CAP_PTR—Capabilities Pointer Register (USB EHCI—D29:F7, D26:F7)	591
15.1.14	INT_LN—Interrupt Line Register (USB EHCI—D29:F7, D26:F7)	591
15.1.15	INT_PN—Interrupt Pin Register (USB EHCI—D29:F7, D26:F7)	591
15.1.16	PWR_CAPID—PCI Power Management Capability ID Register (USB EHCI—D29:F7, D26:F7)	592
15.1.17	NXT_PTR1—Next Item Pointer #1 Register (USB EHCI—D29:F7, D26:F7)	592
15.1.18	PWR_CAP—Power Management Capabilities Register (USB EHCI—D29:F7, D26:F7)	593
15.1.19	PWR_CNTL_STS—Power Management Control/ Status Register (USB EHCI—D29:F7, D26:F7)	594
15.1.20	DEBUG_CAPID—Debug Port Capability ID Register (USB EHCI—D29:F7, D26:F7)	595
15.1.21	NXT_PTR2—Next Item Pointer #2 Register (USB EHCI—D29:F7, D26:F7)	595
15.1.22	DEBUG_BASE—Debug Port Base Offset Register (USB EHCI—D29:F7, D26:F7)	595
15.1.23	USB_RELNUM—USB Release Number Register (USB EHCI—D29:F7, D26:F7)	595
15.1.24	FL_ADJ—Frame Length Adjustment Register (USB EHCI—D29:F7, D26:F7)	596
15.1.25	PWAKE_CAP—Port Wake Capability Register (USB EHCI—D29:F7, D26:F7)	597
15.1.26	LEG_EXT_CAP—USB EHCI Legacy Support Extended Capability Register (USB EHCI—D29:F7, D26:F7)	597
15.1.27	LEG_EXT_CS—USB EHCI Legacy Support Extended Control / Status Register (USB EHCI—D29:F7, D26:F7)	598
15.1.28	SPECIAL_SMI—Intel Specific USB 2.0 SMI Register (USB EHCI—D29:F7, D26:F7)	600
15.1.29	ACCESS_CNTL—Access Control Register (USB EHCI—D29:F7, D26:F7)	601
15.1.30	EHCIIR1—EHCI Initialization Register 1 (Mobile Only) (USB EHCI—D29:F7, D26:F7)	602
15.1.31	EHCIIR2—EHCI Initialization Register 2 (USB EHCI—D29:F7, D26:F7)	602
15.2	Memory-Mapped I/O Registers	603
15.2.1	Host Controller Capability Registers	603
15.2.1.1	CAPLENGTH—Capability Registers Length	604
15.2.1.2	HCIVERSION—Host Controller Interface Version Number	604
15.2.1.3	HCPARAMS—Host Controller Structural Parameters	605
15.2.1.4	HCCPARAMS—Host Controller Capability Parameters Register	606
15.2.2	Host Controller Operational Registers	607
15.2.2.1	USB2.0_CMD—USB 2.0 Command Register	608
15.2.2.2	USB2.0_STS—USB 2.0 Status Register	610
15.2.2.3	USB2.0_INTR—USB 2.0 Interrupt Enable Register	612
15.2.2.4	FRINDEX—Frame Index Register	613
15.2.2.5	CTRLDSSEGMENT—Control Data Structure Segment Register	614
15.2.2.6	PERIODICLISTBASE—Periodic Frame List Base Address Register	614
15.2.2.7	ASYNCLISTADDR—Current Asynchronous List Address Register	615



15.2.2.8	CONFIGFLAG—Configure Flag Register .....	615
15.2.2.9	PORTSC—Port N Status and Control Register.....	616
15.2.3	USB 2.0-Based Debug Port Register .....	620
15.2.3.1	CNTL_STS—Control/Status Register.....	621
15.2.3.2	USBPID—USB PIDs Register .....	622
15.2.3.3	DATABUF[7:0]—Data Buffer Bytes[7:0] Register .....	623
15.2.3.4	CONFIG—Configuration Register.....	623
<b>16</b>	<b>SMBus Controller Registers (D31:F3) .....</b>	<b>625</b>
16.1	PCI Configuration Registers (SMBUS—D31:F3) .....	625
16.1.1	VID—Vendor Identification Register (SMBUS—D31:F3) .....	625
16.1.2	DID—Device Identification Register (SMBUS—D31:F3).....	626
16.1.3	PCICMD—PCI Command Register (SMBUS—D31:F3).....	626
16.1.4	PCISTS—PCI Status Register (SMBUS—D31:F3).....	627
16.1.5	RID—Revision Identification Register (SMBUS—D31:F3).....	627
16.1.6	PI—Programming Interface Register (SMBUS—D31:F3).....	628
16.1.7	SCC—Sub Class Code Register (SMBUS—D31:F3) .....	628
16.1.8	BCC—Base Class Code Register (SMBUS—D31:F3) .....	628
16.1.9	SMBMBAR0 – D31_F3_SMBus Memory Base Address 0 .....	628
16.1.10	SMB_BASE—SMBUS Base Address Register (SMBUS—D31:F3) .....	629
16.1.11	SVID — Subsystem Vendor Identification Register (SMBUS—D31:F2/F4) .....	629
16.1.12	SID — Subsystem Identification Register (SMBUS—D31:F2/F4) .....	629
16.1.13	INT_LN—Interrupt Line Register (SMBUS—D31:F3) .....	630
16.1.14	INT_PN—Interrupt Pin Register (SMBUS—D31:F3) .....	630
16.1.15	HOSTC—Host Configuration Register (SMBUS—D31:F3) .....	630
16.2	SMBus I/O and Memory Mapped I/O Registers .....	631
16.2.1	HST_STS—Host Status Register (SMBUS—D31:F3) .....	632
16.2.2	HST_CNT—Host Control Register (SMBUS—D31:F3) .....	633
16.2.3	HST_CMD—Host Command Register (SMBUS—D31:F3) .....	635
16.2.4	XMIT_SLVA—Transmit Slave Address Register (SMBUS—D31:F3) .....	635
16.2.5	HST_D0—Host Data 0 Register (SMBUS—D31:F3).....	635
16.2.6	HST_D1—Host Data 1 Register (SMBUS—D31:F3).....	635
16.2.7	Host_BLOCK_DB—Host Block Data Byte Register (SMBUS—D31:F3) .....	636
16.2.8	PEC—Packet Error Check (PEC) Register (SMBUS—D31:F3) .....	636
16.2.9	RCV_SLVA—Receive Slave Address Register (SMBUS—D31:F3) .....	637
16.2.10	SLV_DATA—Receive Slave Data Register (SMBUS—D31:F3) .....	637
16.2.11	AUX_STS—Auxiliary Status Register (SMBUS—D31:F3).....	637
16.2.12	AUX_CTL—Auxiliary Control Register (SMBUS—D31:F3).....	638
16.2.13	SMLINK_PIN_CTL—SMLink Pin Control Register (SMBUS—D31:F3) .....	638
16.2.14	SMBUS_PIN_CTL—SMBus Pin Control Register (SMBUS—D31:F3) .....	639
16.2.15	SLV_STS—Slave Status Register (SMBUS—D31:F3) .....	639
16.2.16	SLV_CMD—Slave Command Register (SMBUS—D31:F3) .....	640
16.2.17	NOTIFY_DADDR—Notify Device Address Register (SMBUS—D31:F3) .....	640
16.2.18	NOTIFY_DLOW—Notify Data Low Byte Register (SMBUS—D31:F3) .....	641
16.2.19	NOTIFY_DHIGH—Notify Data High Byte Register (SMBUS—D31:F3) .....	641





<b>17</b>	<b>Intel® High Definition Audio Controller Registers (D27:F0)</b>	<b>643</b>
17.1	Intel® High Definition Audio PCI Configuration Space (Intel® High Definition Audio— D27:F0)	643
17.1.1	VID—Vendor Identification Register (Intel® High Definition Audio Controller—D27:F0)	645
17.1.2	DID—Device Identification Register (Intel® High Definition Audio Controller—D27:F0)	645
17.1.3	PCICMD—PCI Command Register (Intel® High Definition Audio Controller—D27:F0)	646
17.1.4	PCISTS—PCI Status Register (Intel® High Definition Audio Controller—D27:F0)	647
17.1.5	RID—Revision Identification Register (Intel® High Definition Audio Controller—D27:F0)	647
17.1.6	PI—Programming Interface Register (Intel® High Definition Audio Controller—D27:F0)	648
17.1.7	SCC—Sub Class Code Register (Intel® High Definition Audio Controller—D27:F0)	648
17.1.8	BCC—Base Class Code Register (Intel® High Definition Audio Controller—D27:F0)	648
17.1.9	CLS—Cache Line Size Register (Intel® High Definition Audio Controller—D27:F0)	648
17.1.10	LT—Latency Timer Register (Intel® High Definition Audio Controller—D27:F0)	648
17.1.11	HEADTYP—Header Type Register (Intel® High Definition Audio Controller—D27:F0)	649
17.1.12	HDBARL—Intel® High Definition Audio Lower Base Address Register (Intel® High Definition Audio—D27:F0)	649
17.1.13	HDBARU—Intel® High Definition Audio Upper Base Address Register (Intel® High Definition Audio Controller—D27:F0)	649
17.1.14	SVID—Subsystem Vendor Identification Register (Intel® High Definition Audio Controller—D27:F0)	650
17.1.15	SID—Subsystem Identification Register (Intel® High Definition Audio Controller—D27:F0)	650
17.1.16	CAPPTR—Capabilities Pointer Register (Audio—D30:F2)	650
17.1.17	INTLN—Interrupt Line Register (Intel® High Definition Audio Controller—D27:F0)	651
17.1.18	INTPN—Interrupt Pin Register (Intel® High Definition Audio Controller—D27:F0)	651
17.1.19	HDCTL—Intel® High Definition Audio Control Register (Intel® High Definition Audio Controller—D27:F0)	651
17.1.20	TCSEL—Traffic Class Select Register (Intel® High Definition Audio Controller—D27:F0)	652
17.1.21	DCKCTL—Docking Control Register (Intel® High Definition Audio Controller—D27:F0) (Mobile Only)	652
17.1.22	DCKSTS—Docking Status Register (Intel® High Definition Audio Controller—D27:F0) (Mobile Only)	653
17.1.23	PID—PCI Power Management Capability ID Register (Intel® High Definition Audio Controller—D27:F0)	653
17.1.24	PC—Power Management Capabilities Register (Intel® High Definition Audio Controller—D27:F0)	654
17.1.25	PCS—Power Management Control and Status Register (Intel® High Definition Audio Controller—D27:F0)	654
17.1.26	MID—MSI Capability ID Register (Intel® High Definition Audio Controller—D27:F0)	655
17.1.27	MMC—MSI Message Control Register (Intel® High Definition Audio Controller—D27:F0)	655



17.1.28	MMLA—MSI Message Lower Address Register (Intel® High Definition Audio Controller—D27:F0) .....	656
17.1.29	MMUA—MSI Message Upper Address Register (Intel® High Definition Audio Controller—D27:F0) .....	656
17.1.30	MMD—MSI Message Data Register (Intel® High Definition Audio Controller—D27:F0) .....	656
17.1.31	PXID—PCI Express* Capability ID Register (Intel® High Definition Audio Controller—D27:F0) .....	656
17.1.32	PXC—PCI Express* Capabilities Register (Intel® High Definition Audio Controller—D27:F0) .....	657
17.1.33	DEVCAP—Device Capabilities Register (Intel® High Definition Audio Controller—D27:F0) .....	657
17.1.34	DEVC—Device Control Register (Intel® High Definition Audio Controller—D27:F0) .....	658
17.1.35	DEVS—Device Status Register (Intel® High Definition Audio Controller—D27:F0) .....	659
17.1.36	VCCAP—Virtual Channel Enhanced Capability Header (Intel® High Definition Audio Controller—D27:F0) .....	659
17.1.37	PVCCAP1—Port VC Capability Register 1 (Intel® High Definition Audio Controller—D27:F0) .....	660
17.1.38	PVCCAP2 — Port VC Capability Register 2 (Intel® High Definition Audio Controller—D27:F0) .....	660
17.1.39	PVCCTL — Port VC Control Register (Intel® High Definition Audio Controller—D27:F0) .....	660
17.1.40	PVCSTS—Port VC Status Register (Intel® High Definition Audio Controller—D27:F0) .....	661
17.1.41	VC0CAP—VC0 Resource Capability Register (Intel® High Definition Audio Controller—D27:F0) .....	661
17.1.42	VC0CTL—VC0 Resource Control Register (Intel® High Definition Audio Controller—D27:F0) .....	661
17.1.43	VC0STS—VC0 Resource Status Register (Intel® High Definition Audio Controller—D27:F0) .....	662
17.1.44	VCiCAP—VCi Resource Capability Register (Intel® High Definition Audio Controller—D27:F0) .....	662
17.1.45	VCiCTL—VCi Resource Control Register (Intel® High Definition Audio Controller—D27:F0) .....	663
17.1.46	VCiSTS—VCi Resource Status Register (Intel® High Definition Audio Controller—D27:F0) .....	663
17.1.47	RCCAP—Root Complex Link Declaration Enhanced Capability Header Register (Intel® High Definition Audio Controller—D27:F0)	664
17.1.48	ESD—Element Self Description Register (Intel® High Definition Audio Controller—D27:F0) .....	664
17.1.49	L1DESC—Link 1 Description Register (Intel® High Definition Audio Controller—D27:F0) .....	664
17.1.50	L1ADDL—Link 1 Lower Address Register (Intel® High Definition Audio Controller—D27:F0) .....	665
17.1.51	L1ADDU—Link 1 Upper Address Register (Intel® High Definition Audio Controller—D27:F0) .....	665
17.2	Intel® High Definition Audio Memory Mapped Configuration Registers (Intel® High Definition Audio— D27:F0) .....	666
17.2.1	GCAP—Global Capabilities Register (Intel® High Definition Audio Controller—D27:F0) .....	670
17.2.2	VMIN—Minor Version Register (Intel® High Definition Audio Controller—D27:F0) .....	670
17.2.3	VMAJ—Major Version Register (Intel® High Definition Audio Controller—D27:F0) .....	670



17.2.4	OUTPAY—Output Payload Capability Register (Intel® High Definition Audio Controller—D27:F0) .....	671
17.2.5	INPAY—Input Payload Capability Register (Intel® High Definition Audio Controller—D27:F0) .....	671
17.2.6	GCTL—Global Control Register (Intel® High Definition Audio Controller—D27:F0) .....	672
17.2.7	WAKEEN—Wake Enable Register (Intel® High Definition Audio Controller—D27:F0) .....	673
17.2.8	STATESTS—State Change Status Register (Intel® High Definition Audio Controller—D27:F0) .....	673
17.2.9	GSTS—Global Status Register (Intel® High Definition Audio Controller—D27:F0) .....	674
17.2.10	ECAP—Extended Capabilities (Intel® High Definition Audio Controller—D27:F0) .....	675
17.2.11	OUTSTRMPAY—Output Stream Payload Capability (Intel® High Definition Audio Controller—D27:F0) .....	675
17.2.12	INSTRMPAY—Input Stream Payload Capability (Intel® High Definition Audio Controller—D27:F0) .....	676
17.2.13	INTCTL—Interrupt Control Register (Intel® High Definition Audio Controller—D27:F0) .....	677
17.2.14	INTSTS—Interrupt Status Register (Intel® High Definition Audio Controller—D27:F0) .....	678
17.2.15	WALCLK—Wall Clock Counter Register (Intel® High Definition Audio Controller—D27:F0) .....	679
17.2.16	SSYNC—Stream Synchronization Register (Intel® High Definition Audio Controller—D27:F0) .....	679
17.2.17	CORBLOWERBASE—CORB Lower Base Address Register (Intel® High Definition Audio Controller—D27:F0) .....	680
17.2.18	CORBUPPERBASE—CORB Upper Base Address Register (Intel® High Definition Audio Controller—D27:F0) .....	680
17.2.19	CORBWP—CORB Write Pointer Register (Intel® High Definition Audio Controller—D27:F0) .....	680
17.2.20	CORBWP—CORB Read Pointer Register (Intel® High Definition Audio Controller—D27:F0) .....	681
17.2.21	CORBCTL—CORB Control Register (Intel® High Definition Audio Controller—D27:F0) .....	681
17.2.22	CORBST—CORB Status Register (Intel® High Definition Audio Controller—D27:F0) .....	682
17.2.23	CORBFSIZE—CORB Size Register (Intel® High Definition Audio Controller—D27:F0) .....	682
17.2.24	RIRBLOWERBASE—RIRB Lower Base Address Register (Intel® High Definition Audio Controller—D27:F0) .....	682
17.2.25	RIRBUPPERBASE—RIRB Upper Base Address Register (Intel® High Definition Audio Controller—D27:F0) .....	683
17.2.26	RIRBWP—RIRB Write Pointer Register (Intel® High Definition Audio Controller—D27:F0) .....	683
17.2.27	RINTCNT—Response Interrupt Count Register (Intel® High Definition Audio Controller—D27:F0) .....	684
17.2.28	RIRBCTL—RIRB Control Register (Intel® High Definition Audio Controller—D27:F0) .....	684
17.2.29	RIRBSTS—RIRB Status Register (Intel® High Definition Audio Controller—D27:F0) .....	685
17.2.30	RIRBFSIZE—RIRB Size Register (Intel® High Definition Audio Controller—D27:F0) .....	685
17.2.31	IC—Immediate Command Register (Intel® High Definition Audio Controller—D27:F0) .....	685



17.2.32	IR—Immediate Response Register (Intel® High Definition Audio Controller—D27:F0) .....	686
17.2.33	IRS—Immediate Command Status Register (Intel® High Definition Audio Controller—D27:F0) .....	686
17.2.34	DPLBASE—DMA Position Lower Base Address Register (Intel® High Definition Audio Controller—D27:F0) .....	687
17.2.35	DPUBASE—DMA Position Upper Base Address Register (Intel® High Definition Audio Controller—D27:F0) .....	687
17.2.36	SDCTL—Stream Descriptor Control Register (Intel® High Definition Audio Controller—D27:F0) .....	688
17.2.37	SDSTS—Stream Descriptor Status Register (Intel® High Definition Audio Controller—D27:F0) .....	690
17.2.38	SDLPIB—Stream Descriptor Link Position in Buffer Register (Intel® High Definition Audio Controller—D27:F0) .....	691
17.2.39	SDCBL—Stream Descriptor Cyclic Buffer Length Register (Intel® High Definition Audio Controller—D27:F0) .....	691
17.2.40	SDLVI—Stream Descriptor Last Valid Index Register (Intel® High Definition Audio Controller—D27:F0) .....	692
17.2.41	SDFIFOW—Stream Descriptor FIFO Watermark Register (Intel® High Definition Audio Controller—D27:F0) .....	692
17.2.42	SDFIFOS—Stream Descriptor FIFO Size Register (Intel® High Definition Audio Controller—D27:F0) .....	693
17.2.43	SDFMT—Stream Descriptor Format Register (Intel® High Definition Audio Controller—D27:F0) .....	694
17.2.44	SDBDPL—Stream Descriptor Buffer Descriptor List Pointer Lower Base Address Register (Intel® High Definition Audio Controller—D27:F0) .....	695
17.2.45	SDBDPU—Stream Descriptor Buffer Descriptor List Pointer Upper Base Address Register (Intel® High Definition Audio Controller—D27:F0) .....	695
<b>18</b>	<b>PCI Express* Configuration Registers</b> .....	<b>697</b>
18.1	PCI Express* Configuration Registers (PCI Express—D28:F0/F1/F2/F3/F4/F5) .....	697
18.1.1	VID—Vendor Identification Register (PCI Express—D28:F0/F1/F2/F3/F4/F5) .....	700
18.1.2	DID—Device Identification Register (PCI Express—D28:F0/F1/F2/F3/F4/F5) .....	700
18.1.3	PCICMD—PCI Command Register (PCI Express—D28:F0/F1/F2/F3/F4/F5) .....	701
18.1.4	PCISTS—PCI Status Register (PCI Express—D28:F0/F1/F2/F3/F4/F5) .....	702
18.1.5	RID—Revision Identification Register (PCI Express—D28:F0/F1/F2/F3/F4/F5) .....	703
18.1.6	PI—Programming Interface Register (PCI Express—D28:F0/F1/F2/F3/F4/F5) .....	703
18.1.7	SCC—Sub Class Code Register (PCI Express—D28:F0/F1/F2/F3/F4/F5) .....	703
18.1.8	BCC—Base Class Code Register (PCI Express—D28:F0/F1/F2/F3/F4/F5) .....	703
18.1.9	CLS—Cache Line Size Register (PCI Express—D28:F0/F1/F2/F3/F4/F5) .....	704
18.1.10	PLT—Primary Latency Timer Register (PCI Express—D28:F0/F1/F2/F3/F4/F5) .....	704
18.1.11	HEADTYP—Header Type Register (PCI Express—D28:F0/F1/F2/F3/F4/F5) .....	704
18.1.12	BNUM—Bus Number Register (PCI Express—D28:F0/F1/F2/F3/F4/F5) .....	704



18.1.13 SLT—Secondary Latency Timer (PCI Express—D28: F0/F1/F2/F3/F4/F5).....	705
18.1.14 IOBL—I/O Base and Limit Register (PCI Express—D28: F0/F1/F2/F3/F4/F5).....	705
18.1.15 SSTS—Secondary Status Register (PCI Express—D28: F0/F1/F2/F3/F4/F5).....	706
18.1.16 MBL—Memory Base and Limit Register (PCI Express—D28: F0/F1/F2/F3/F4/F5).....	707
18.1.17 PMBL—Prefetchable Memory Base and Limit Register (PCI Express—D28: F0/F1/F2/F3/F4/F5).....	707
18.1.18 PMBU32—Prefetchable Memory Base Upper 32 Bits Register (PCI Express—D28: F0/F1/F2/F3/F4/F5).....	708
18.1.19 PMLU32—Prefetchable Memory Limit Upper 32 Bits Register (PCI Express—D28: F0/F1/F2/F3/F4/F5).....	708
18.1.20 CAPP—Capabilities List Pointer Register (PCI Express—D28: F0/F1/F2/F3/F4/F5).....	708
18.1.21 INTR—Interrupt Information Register (PCI Express—D28: F0/F1/F2/F3/F4/F5).....	709
18.1.22 BCTRL—Bridge Control Register (PCI Express—D28: F0/F1/F2/F3/F4/F5).....	709
18.1.23 CLIST—Capabilities List Register (PCI Express—D28: F0/F1/F2/F3/F4/F5).....	710
18.1.24 XCAP—PCI Express* Capabilities Register (PCI Express—D28: F0/F1/F2/F3/F4/F5).....	710
18.1.25 DCAP—Device Capabilities Register (PCI Express—D28: F0/F1/F2/F3/F4/F5).....	711
18.1.26 DCTL—Device Control Register (PCI Express—D28: F0/F1/F2/F3/F4/F5).....	712
18.1.27 DSTS—Device Status Register (PCI Express—D28: F0/F1/F2/F3/F4/F5).....	713
18.1.28 LCAP—Link Capabilities Register (PCI Express—D28: F0/F1/F2/F3/F4/F5).....	713
18.1.29 LCTL—Link Control Register (PCI Express—D28: F0/F1/F2/F3/F4/F5).....	715
18.1.30 LSTS—Link Status Register (PCI Express—D28: F0/F1/F2/F3/F4/F5).....	716
18.1.31 SLCAP—Slot Capabilities Register (PCI Express—D28: F0/F1/F2/F3/F4/F5).....	717
18.1.32 SLCTL—Slot Control Register (PCI Express—D28: F0/F1/F2/F3/F4/F5).....	718
18.1.33 SLSTS—Slot Status Register (PCI Express—D28: F0/F1/F2/F3/F4/F5).....	719
18.1.34 RCTL—Root Control Register (PCI Express—D28: F0/F1/F2/F3/F4/F5).....	720
18.1.35 RSTS—Root Status Register (PCI Express—D28: F0/F1/F2/F3/F4/F5).....	720
18.1.36 MID—Message Signaled Interrupt Identifiers Register (PCI Express—D28: F0/F1/F2/F3/F4/F5).....	721
18.1.37 MC—Message Signaled Interrupt Message Control Register (PCI Express—D28: F0/F1/F2/F3/F4/F5).....	721
18.1.38 MA—Message Signaled Interrupt Message Address Register (PCI Express—D28: F0/F1/F2/F3/F4/F5).....	721
18.1.39 MD—Message Signaled Interrupt Message Data Register (PCI Express—D28: F0/F1/F2/F3/F4/F5).....	722
18.1.40 SVCAP—Subsystem Vendor Capability Register (PCI Express—D28: F0/F1/F2/F3/F4/F5).....	722



18.1.41	SVID—Subsystem Vendor Identification Register (PCI Express—D28: F0/F1/F2/F3/F4/F5) .....	722
18.1.42	PMCAP—Power Management Capability Register (PCI Express—D28: F0/F1/F2/F3/F4/F5) .....	722
18.1.43	PMC—PCI Power Management Capabilities Register (PCI Express—D28: F0/F1/F2/F3/F4/F5) .....	723
18.1.44	PMCS—PCI Power Management Control and Status Register (PCI Express—D28: F0/F1/F2/F3/F4/F5) .....	724
18.1.45	MPC—Miscellaneous Port Configuration Register (PCI Express—D28: F0/F1/F2/F3/F4/F5) .....	725
18.1.46	SMSCS—SMI/SCI Status Register (PCI Express—D28: F0/F1/F2/F3/F4/F5) .....	727
18.1.47	RPDCGEN—Root Port Dynamic Clock Gating Enable (PCI Express—D28: F0/F1/F2/F3/F4/F5) (Mobile Only) .....	728
18.1.48	IPWS—Intel® PRO/Wireless 3945ABG Status (PCI Express—D28: F0/F1/F2/F3/F4/F5) .....	728
18.1.49	VCH—Virtual Channel Capability Header Register (PCI Express—D28: F0/F1/F2/F3/F4/F5) .....	729
18.1.50	VCAP2—Virtual Channel Capability 2 Register (PCI Express—D28: F0/F1/F2/F3/F4/F5) .....	729
18.1.51	PVC—Port Virtual Channel Control Register (PCI Express—D28: F0/F1/F2/F3/F4/F5) .....	729
18.1.52	PVS — Port Virtual Channel Status Register (PCI Express—D28: F0/F1/F2/F3/F4/F5) .....	729
18.1.53	VOCAP — Virtual Channel 0 Resource Capability Register (PCI Express—D28: F0/F1/F2/F3/F4/F5) .....	730
18.1.54	VOCTL — Virtual Channel 0 Resource Control Register (PCI Express—D28: F0/F1/F2/F3/F4/F5) .....	731
18.1.55	VOSTS — Virtual Channel 0 Resource Status Register (PCI Express—D28: F0/F1/F2/F3/F4/F5) .....	731
18.1.56	UES — Uncorrectable Error Status Register (PCI Express—D28: F0/F1/F2/F3/F4/F5) .....	732
18.1.57	UEM — Uncorrectable Error Mask (PCI Express—D28: F0/F1/F2/F3/F4/F5) .....	733
18.1.58	UEV — Uncorrectable Error Severity (PCI Express—D28: F0/F1/F2/F3/F4/F5) .....	734
18.1.59	CES — Correctable Error Status Register (PCI Express—D28: F0/F1/F2/F3/F4/F5) .....	735
18.1.60	CEM — Correctable Error Mask Register (PCI Express—D28: F0/F1/F2/F3/F4/F5) .....	736
18.1.61	AECC — Advanced Error Capabilities and Control Register (PCI Express—D28: F0/F1/F2/F3/F4/F5) .....	736
18.1.62	RES — Root Error Status Register (PCI Express—D28: F0/F1/F2/F3/F4/F5) .....	737
18.1.63	RCTCL — Root Complex Topology Capability List Register (PCI Express—D28: F0/F1/F2/F3/F4/F5) .....	737
18.1.64	ESD — Element Self Description Register (PCI Express—D28: F0/F1/F2/F3/F4/F5) .....	738
18.1.65	ULD — Upstream Link Description Register (PCI Express—D28: F0/F1/F2/F3/F4/F5) .....	738
18.1.66	ULBA — Upstream Link Base Address Register (PCI Express—D28: F0/F1/F2/F3/F4/F5) .....	739
18.1.67	PEETM — PCI Express* Extended Test Mode Register (PCI Express—D28: F0/F1/F2/F3/F4/F5) .....	739
<b>19</b>	<b>High Precision Event Timer Registers</b> .....	<b>741</b>
19.1	Memory-Mapped Registers .....	741
19.1.1	GCAP_ID—General Capabilities and Identification Register .....	742



19.1.2	GEN_CONF—General Configuration Register	743
19.1.3	GINTR_STA—General Interrupt Status Register	743
19.1.4	MAIN_CNT—Main Counter Value Register	744
19.1.5	TIMn_CONF—Timer n Configuration and Capabilities Register	744
19.1.6	TIMn_COMP—Timer n Comparator Value Register	746
<b>20</b>	<b>Serial Peripheral Interface (SPI)</b>	<b>747</b>
20.1	Serial Peripheral Interface Memory-Mapped Configuration Registers	747
20.1.1	BFPR—BIOS Flash Primary Region Register (SPI Memory Mapped Configuration Registers)	748
20.1.2	HSFS—Hardware Sequencing Flash Status Register (SPI Memory Mapped Configuration Registers)	749
20.1.3	HSFC—Hardware Sequencing Flash Control Register (SPI Memory Mapped Configuration Registers)	750
20.1.4	FADDR—Flash Address Register (SPI Memory Mapped Configuration Registers)	751
20.1.5	FDATA0—Flash Data 0 Register (SPI Memory Mapped Configuration Registers)	751
20.1.6	FDATAN—Flash Data [N] Register (SPI Memory Mapped Configuration Registers)	751
20.1.7	FRAP—Flash Regions Access Permissions Register (SPI Memory Mapped Configuration Registers)	752
20.1.8	FREG0—Flash Region 0 (Flash Descriptor) Register (SPI Memory Mapped Configuration Registers)	752
20.1.9	FREG1—Flash Region 1 (BIOS Descriptor) Register (SPI Memory Mapped Configuration Registers)	753
20.1.10	FREG2—Flash Region 2 (ME) Register (SPI Memory Mapped Configuration Registers)	753
20.1.11	FREG3—Flash Region 3 (GbE) Register (SPI Memory Mapped Configuration Registers)	754
20.1.12	PR0—Protected Range 0 Register (SPI Memory Mapped Configuration Registers)	754
20.1.13	PR1—Protected Range 1 Register (SPI Memory Mapped Configuration Registers)	755
20.1.14	PR2—Protected Range 2 Register (SPI Memory Mapped Configuration Registers)	755
20.1.15	PR3—Protected Range 3 Register (SPI Memory Mapped Configuration Registers)	756
20.1.16	PR4—Protected Range 4 Register (SPI Memory Mapped Configuration Registers)	756
20.1.17	SSFS—Software Sequencing Flash Status Register (SPI Memory Mapped Configuration Registers)	757
20.1.18	SSFC—Software Sequencing Flash Control Register (SPI Memory Mapped Configuration Registers)	758
20.1.19	PREOP—Prefix Opcode Configuration Register (SPI Memory Mapped Configuration Registers)	759
20.1.20	OPTYPE—Opcode Type Configuration Register (SPI Memory Mapped Configuration Registers)	759
20.1.21	OPMENU—Opcode Menu Configuration Register (SPI Memory Mapped Configuration Registers)	760
20.1.22	FDOC—Flash Descriptor Observability Control Register (SPI Memory Mapped Configuration Registers)	761
20.1.23	FDOD—Flash Descriptor Observability Data Register (SPI Memory Mapped Configuration Registers)	761
20.1.24	VSCC—Vendor Specific Component Capabilities Register (SPI Memory Mapped Configuration Registers)	762
20.2	Flash Descriptor Registers	763



20.2.1	Flash Descriptor Content.....	763
20.2.1.1	FLVALSIG—Flash Valid Signature Register (Flash Descriptor Memory Mapped Configuration Registers) .....	763
20.2.1.2	FLMAP0—Flash Map 0 Register (Flash Descriptor Memory Mapped Configuration Registers) .....	763
20.2.1.3	FLMAP1—Flash Map 1 Register (Flash Descriptor Memory Mapped Configuration Registers) .....	764
20.2.1.4	FLMAP2—Flash Map 2 Register (Flash Descriptor Memory Mapped Configuration Registers) .....	764
20.2.2	Flash Descriptor Component Section .....	765
20.2.2.1	FLCOMP—Flash Components Register (Flash Descriptor Memory Mapped Configuration Registers) .....	765
20.2.2.2	FLILL—Flash Invalid Instructions Register (Flash Descriptor Memory Mapped Configuration Registers) .....	766
20.2.3	Flash Descriptor Region Section .....	767
20.2.3.1	FLREG0—Flash Region 0 (Flash Descriptor) Register (Flash Descriptor Memory Mapped Configuration Registers) .....	767
20.2.3.2	FLREG1—Flash Region 1 (BIOS) Register (Flash Descriptor Memory Mapped Configuration Registers) .....	767
20.2.3.3	FLREG2—Flash Region 2 (ME) Register (Flash Descriptor Memory Mapped Configuration Registers) .....	768
20.2.3.4	FLREG3—Flash Region 3 (GbE) Register (Flash Descriptor Memory Mapped Configuration Registers) .....	768
20.2.4	Flash Descriptor Master Section .....	769
20.2.4.1	FLMSTR1—Flash Master 1 (Host Processor/ BIOS).....	769
20.2.4.2	FLMSTR2—Flash Master 2 (ME) .....	769
20.2.4.3	FLMSTR3—Flash Master 3 (GbE).....	770
20.2.5	Flash Descriptor Strap .....	771
20.2.5.1	STRP0—Strap 0 Register (Flash Descriptor Memory Mapped Configuration Registers) .....	771
20.2.5.2	STRP1—Strap 1 Register (Flash Descriptor Memory Mapped Configuration Registers) .....	772
20.2.5.3	FLUMAP1—Flash Upper Map 1 .....	773
20.2.5.4	JIDO—JEDEC-ID 0 Register .....	773
20.2.5.5	VSCC0—Vendor Specific Component Capabilities 0.....	773
20.2.5.6	JIDO—JEDEC-ID n Register .....	774
20.2.5.7	VSCC0n—Vendor Specific Component Capabilities n.....	775
20.2.5.8	OEM Section .....	776
20.3	GbE SPI Flash Program Registers .....	776
20.3.1	GLFPR—Gigabit LAN Flash Primary Region Register (GbE LAN Memory Mapped Configuration Registers) .....	777
20.3.2	HSFS—Hardware Sequencing Flash Status Register (GbE LAN Memory Mapped Configuration Registers) .....	778
20.3.3	HSFC—Hardware Sequencing Flash Control Register (GbE LAN Memory Mapped Configuration Registers) .....	779
20.3.4	FADDR—Flash Address Register (GbE LAN Memory Mapped Configuration Registers) .....	780
20.3.5	FDATA0—Flash Data 0 Register (GbE LAN Memory Mapped Configuration Registers) .....	780
20.3.6	FRAP—Flash Regions Access Permissions Register (GbE LAN Memory Mapped Configuration Registers) .....	781
20.3.7	FREG0—Flash Region 0 (Flash Descriptor) Register (GbE LAN Memory Mapped Configuration Registers) .....	782
20.3.8	FREG1—Flash Region 1 (BIOS Descriptor) Register (GbE LAN Memory Mapped Configuration Registers) .....	782
20.3.9	FREG2—Flash Region 2 (ME) Register (GbE LAN Memory Mapped Configuration Registers) .....	783

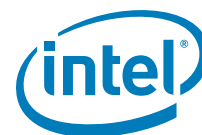




20.3.10	FREG3—Flash Region 3 (GbE) Register (GbE LAN Memory Mapped Configuration Registers).....	783
20.3.11	PRO—Protected Range 0 Register (GbE LAN Memory Mapped Configuration Registers).....	784
20.3.12	PR1—Protected Range 1 Register (GbE LAN Memory Mapped Configuration Registers).....	784
20.3.13	SSFS—Software Sequencing Flash Status Register (GbE LAN Memory Mapped Configuration Registers).....	785
20.3.14	SSFC—Software Sequencing Flash Control Register (GbE LAN Memory Mapped Configuration Registers).....	786
20.3.15	PREOP—Prefix Opcode Configuration Register (GbE LAN Memory Mapped Configuration Registers).....	787
20.3.16	OPTYPE—Opcode Type Configuration Register (GbE LAN Memory Mapped Configuration Registers).....	787
20.3.17	OPMENU—Opcode Menu Configuration Register (GbE LAN Memory Mapped Configuration Registers).....	788
<b>21</b>	<b>Thermal Sensor Registers (D31:F6).....</b>	<b>789</b>
21.1	PCI Bus Configuration Registers.....	789
21.1.1	VID—Vendor Identification.....	790
21.1.2	DID—Device Identification.....	790
21.1.3	CMD—Command.....	790
21.1.4	STS—Status.....	791
21.1.5	RID—Revision Identification.....	791
21.1.6	PI— Programming Interface.....	791
21.1.7	SCC—Sub Class Code.....	792
21.1.8	BCC—Base Class Code.....	792
21.1.9	CLS—Cache Line Size.....	792
21.1.10	LT—Latency Timer.....	792
21.1.11	HTYPE—Header Type.....	792
21.1.12	BIST—Built-in Self Test.....	793
21.1.13	TBAR—Thermal Base.....	793
21.1.14	TBARH—Thermal Base High DWord.....	793
21.1.15	SVID—Subsystem Vendor ID.....	794
21.1.16	SID—Subsystem ID.....	794
21.1.17	CAP_PTR —Capabilities Pointer.....	794
21.1.18	INTLN—Interrupt Line.....	794
21.1.19	INTPN—Interrupt Pin.....	795
21.1.20	TBARB—BIOS Assigned Thermal Base Address.....	795
21.1.21	TBARBH—BIOS Assigned Thermal Base High DWord.....	795
21.1.22	PID—PCI Power Management Capability ID.....	796
21.1.23	PC—Power Management Capabilities.....	796
21.1.24	PCS—Power Management Control And Status.....	797
21.2	Thermal Memory Mapped Configuration Registers (Thermal Sensor - D31:F26).....	798
21.2.1	TSxE—Thermal Sensor [1:0] Enable.....	798
21.2.2	TSxS—Thermal Sensor[1:0] Status.....	798
21.2.3	TSxTTP—Thermal Sensor [1:0] Catastrophic Trip Point.....	798
21.2.4	TSxCO—Thermal Sensor [1:0] Catastrophic Lock-Down.....	799
21.2.5	TSxPC—Thermal Sensor [1:0] Policy Control.....	799
21.2.6	TSxLOCK—Thermal Sensor [1:0] Register Lock Control.....	799
<b>22</b>	<b>Ballout Definition.....</b>	<b>801</b>
22.1	Ballout (Desktop Only).....	801
22.2	Ballout (Mobile Only).....	810
<b>23</b>	<b>Electrical Characteristics.....</b>	<b>819</b>



23.1	Thermal Specifications.....	819
23.2	Absolute Maximum Ratings <sup>4</sup> .....	819
23.3	DC Characteristics .....	820
23.4	AC Characteristics.....	832
23.5	Timing Diagrams .....	851
<b>24</b>	<b>Package Information</b> .....	<b>867</b>
24.1	Package Dimensions (Desktop Only).....	867
24.2	Package Dimensions (Mobile Only) .....	869
<b>A</b>	<b>Register Bit Index</b> .....	<b>872</b>



## Figures

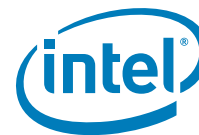
Note: Desktop Configuration .....	43
Note: <a href="#">Mobile Configuration</a> .....	43
1 Intel® ICH8 Interface Signals Block Diagram (Desktop).....	58
2 Intel® ICH8 Interface Signals Block Diagram (Mobile) .....	59
3 Example External RTC Circuit.....	90
4 Desktop Conceptual System Clock Diagram .....	108
5 Mobile Conceptual Clock Diagram .....	108
6 Generation of SERR# to Platform .....	115
7 LPC Interface Diagram.....	124
8 Intel® ICH8 DMA Controller .....	129
9 DMA Request Assertion through LDRQ# .....	132
10 Coprocessor Error Timing Diagram .....	157
11 Advanced TCO Intel® AMT Mode SMBus/SMLink Configuration.....	187
12 Advanced TCO BMC Mode SMBus/SMLink Configuration.....	188
13 Physical Region Descriptor Table Entry.....	191
14 SATA Power States.....	200
15 USB Legacy Keyboard Flow Diagram.....	211
16 Intel® ICH8-USB Port Connections .....	218
17 Flash Descriptor.....	244
18 Ballout (Top View–Left Side) (Desktop Only).....	802
19 Ballout (Top View–Right Side) (Desktop Only).....	803
20 Ballout (Top View–Left Side) (Mobile Only) .....	810
21 Ballout (Top View–Right Side) (Mobile Only) .....	811
22 Clock Timing .....	851
23 Valid Delay from Rising Clock Edge.....	851
24 Setup and Hold Times.....	852
25 Float Delay.....	852
26 Pulse Width .....	852
27 Output Enable Delay.....	852
28 IDE PIO Mode (Mobile Only) .....	853
29 IDE Multiword DMA (Mobile Only) .....	853
30 Ultra ATA Mode (Drive Initiating a Burst Read) (Mobile Only) .....	854
31 Ultra ATA Mode (Sustained Burst) (Mobile Only) .....	854
32 Ultra ATA Mode (Pausing a DMA Burst) (Mobile Only) .....	855
33 Ultra ATA Mode (Terminating a DMA Burst) (Mobile Only) .....	855
34 USB Rise and Fall Times.....	856
35 USB Jitter .....	856
36 USB EOP Width.....	856
37 SMBus Transaction .....	857
38 SMBus Timeout.....	857
39 Power Sequencing and Reset Signal Timings.....	858
40 G3 (Mechanical Off) to S0 Timings.....	859
41 S0 to S1 to S0 Timing.....	860
42 S0 to S5 to S0 Timings, S3 (Desktop Only) .....	860
43 S0 to S5 to S0 Timings, S3 (Mobile Only) .....	861
44 C0 to C2 to C0 Timings (Mobile Only) .....	861
45 C0 to C3 to C0 Timings (Mobile Only) .....	862
46 C0 to C4 to C0 Timings (Mobile Only) .....	862
47 Intel® High Definition Audio Input and Output Timings.....	863
48 SPI Timings.....	863
49 Sleep control signal relationship – Host boots and ME off.....	864
50 Sleep control signal relationship – Host and ME boot after G3 .....	864



51	Sleep Control Signal Relationship – Host stays in S5 and ME boots after G3865	
52	S0 to G3 PWROK and Vcc Timing .....	865
53	S0 to G3 Timings (Mobile Only) .....	865
54	Package Dimensions (Top View) (Desktop Only) .....	867
55	Package Dimensions (Bottom View) (Desktop Only) .....	868
56	Package Dimensions (Side View) (Desktop Only) .....	868
57	Package Dimensions (Top View) (Mobile Only) .....	869
58	Package Dimensions (Bottom View) (Mobile Only) .....	870
59	Package Dimensions (Side View) (Mobile Only) .....	870

## Tables

1	Industry Specifications .....	45
2	PCI Devices and Functions .....	49
3	Intel® ICH8 Desktop/Server Family .....	55
4	Intel® ICH8 Mobile Family .....	55
5	Direct Media Interface Signals .....	60
6	PCI Express* Signals .....	60
7	LAN Connect Interface Signals .....	61
8	Gigabit LAN Connect Interface Signals .....	61
9	Firmware Hub Interface Signals .....	62
10	PCI Interface Signals .....	63
11	Serial ATA Interface Signals .....	66
12	IDE Interface Signals (Mobile Only) .....	68
13	LPC Interface Signals .....	69
14	Interrupt Signals .....	70
15	USB Interface Signals .....	71
16	Power Management Interface Signals .....	72
17	Processor Interface Signals .....	75
18	SM Bus Interface Signals .....	77
19	System Management Interface Signals .....	77
20	Real Time Clock Interface .....	78
21	Other Clocks .....	79
22	Miscellaneous Signals .....	79
23	Intel® High Definition Audio Link Signals .....	80
24	Serial Peripheral Interface (SPI) Signals .....	81
25	Intel® Quick Resume Technology Signals .....	82
26	Controller Link Signals .....	82
27	Intel® Quiet System Technology Signals .....	83
28	General Purpose I/O Signals .....	83
29	Power and Ground Signals .....	86
30	Functional Strap Definitions .....	88
31	Integrated Pull-Up and Pull-Down Resistors .....	91
32	IDE Series Termination Resistors .....	92
33	Power Plane and States for Output and I/O Signals for Desktop Configurations	93
34	Power Plane and States for Output and I/O Signals for Mobile Configurations	98
35	Power Plane for Input Signals for Desktop Configurations .....	102
36	Power Plane for Input Signals for Mobile Configurations .....	104
37	Intel® ICH8 and System Clock Domains .....	107
38	PCI Bridge Initiator Cycle Types .....	109
39	Type 1 Address Format .....	112
40	MSI vs. PCI IRQ Actions .....	113



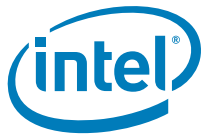
41	LAN Mode Support .....	120
42	LPC Cycle Types Supported .....	125
43	Start Field Bit Definitions .....	125
44	Cycle Type Bit Definitions .....	126
45	Transfer Size Bit Definition .....	126
46	SYNC Bit Definition .....	127
47	DMA Transfer Size .....	131
48	Address Shifting in 16-Bit I/O DMA Transfers .....	131
49	Counter Operating Modes .....	137
50	Interrupt Controller Core Connections .....	139
51	Interrupt Status Registers .....	140
52	Content of Interrupt Vector Byte .....	140
53	APIC Interrupt Mapping .....	146
54	Interrupt Message Address Format .....	148
55	Interrupt Message Data Format .....	149
56	Stop Frame Explanation .....	150
57	Data Frame Format .....	151
58	Configuration Bits Reset by RTCRST# Assertion .....	154
59	INIT# Going Active .....	156
60	NMI Sources .....	157
61	DP Signal Differences .....	158
62	General Power States for Systems Using Intel® ICH8 .....	160
63	State Transition Rules for Intel® ICH8 .....	161
64	System Power Plane .....	162
65	Causes of SMI# and SCI .....	163
66	Break Events (Mobile Only) .....	166
67	Sleep Types .....	170
68	Causes of Wake Events .....	170
69	GPI Wake Events .....	171
70	Transitions Due to Power Failure .....	172
71	Transitions Due to Power Button .....	174
72	Transitions Due to RI# Signal .....	175
73	Write Only Registers with Read Paths in ALT Access Mode .....	178
74	PIC Reserved Bits Return Values .....	180
75	Register Write Accesses in ALT Access Mode .....	180
76	Intel® ICH8 Clock Inputs .....	182
77	TCO Legacy/Compatible Mode SMBus Configuration .....	186
78	Event Transitions that Cause Messages .....	186
79	IDE Transaction Timings (PCI Clocks) .....	190
80	Interrupt/Active Bit Interaction Definition .....	193
81	SATA Feature Support .....	196
82	SATA Feature Support .....	197
83	Legacy Replacement Routing .....	203
84	Bits Maintained in Low Power States .....	210
85	USB Legacy Keyboard State Transitions .....	211
86	UHCI vs. EHCI .....	213
87	Debug Port Behavior .....	221
88	I <sup>2</sup> C Block Read .....	228
89	Enable for SMBALERT# .....	231
90	Enables for SMBus Slave Write and SMBus Host Events .....	231
91	Enables for the Host Notify Command .....	231
92	Slave Write Registers .....	233
93	Command Types .....	234
94	Slave Read Cycle Format .....	235
95	Data Values for Slave Read Registers .....	235



96	Host Notify Format .....	237
97	Required Commands and Opcodes .....	247
98	Recommended Command and Opcode Associations .....	248
99	PCI Devices and Functions .....	256
100	Fixed I/O Ranges Decoded by Intel® ICH8 .....	258
101	Variable I/O Decode Ranges .....	260
102	Memory Decode Ranges from Processor Perspective .....	261
103	Chipset Configuration Register Memory Map (Memory Space) .....	265
104	Gigabit LAN Configuration Registers Address Map (Gigabit LAN —D25:F0) .....	309
105	LPC Interface PCI Register Address Map (LPC I/F—D31:F0) .....	323
106	DMA Registers .....	344
107	PIC Registers (LPC I/F—D31:F0) .....	356
108	APIC Direct Registers (LPC I/F—D31:F0) .....	364
109	APIC Indirect Registers (LPC I/F—D31:F0) .....	364
110	RTC I/O Registers (LPC I/F—D31:F0) .....	369
111	RTC (Standard) RAM Bank (LPC I/F—D31:F0) .....	370
112	Processor Interface PCI Register Address Map (LPC I/F—D31:F0) .....	374
113	Power Management PCI Register Address Map (PM—D31:F0) .....	377
114	APM Register Map .....	390
115	ACPI and Legacy I/O Register Map .....	391
116	TCO I/O Register Address Map .....	416
117	Registers to Control GPIO Address Map .....	423
118	PCI Bridge Register Address Map (PCI-PCI—D30:F0) .....	431
119	IDE Controller PCI Register Address Map (IDE-D31:F1) .....	447
120	Bus Master IDE I/O Registers .....	462
121	SATA Controller PCI Register Address Map (SATA—D31:F2) .....	465
122	SATA Indexed Registers .....	491
123	Bus Master IDE I/O Register Address Map .....	502
124	AHCI Register Address Map .....	512
125	Generic Host Controller Register Address Map .....	513
126	Port [3:0] DMA Register Address Map .....	521
127	SATA Controller PCI Register Address Map (SATA—D31:F5) .....	539
128	Bus Master IDE I/O Register Address Map .....	556
129	UHCI Controller PCI Configuration Map .....	565
130	UHCI Controller PCI Register Address Map (USB—D29:F0/F1/F2, D26:F0/F1) .....	565
131	USB I/O Registers .....	575
132	Run/Stop, Debug Bit Interaction SWDBG (Bit 5), Run/Stop (Bit 0) Operation .....	578
133	USB EHCI PCI Register Address Map (USB EHCI—D29:F7, D26:F7) .....	585
134	Enhanced Host Controller Capability Registers .....	603
135	Enhanced Host Controller Operational Register Address Map .....	607
136	Debug Port Register Address Map .....	620
137	SMBus Controller PCI Register Address Map (SMBUS—D31:F3) .....	625
138	SMBus I/O and Memory Mapped I/O Register Address Map .....	631
139	Intel® High Definition Audio PCI Register Address Map (Intel® High Definition Audio D27:F0) .....	643
140	Intel® High Definition Audio PCI Register Address Map (Intel® High Definition Audio D27:F0) .....	666
141	PCI Express* Configuration Registers Address Map (PCI Express—D28:F0/F1/F2/F3/F4/F5) .....	697
142	Memory-Mapped Registers .....	741
143	Serial Peripheral Interface (SPI) Register Address Map (SPI Memory Mapped Configuration Registers) .....	747



144 Gigabit LAN SPI Flash Program Register Address Map (GbE LAN Memory Mapped Configuration Registers).....	776
145 Thermal Sensor Register Address Map (D31:F6).....	789
146 Ballout by Signal Name (Desktop Only).....	804
147 Ballout by Signal Name (Mobile Only).....	812
148 Intel® ICH8 Absolute Maximum Ratings.....	819
149 DC Current Characteristics (Desktop Only).....	820
150 DC Current Characteristics (Mobile Only).....	821
151 DC Characteristic Input Signal Association.....	822
152 DC Input Characteristics.....	823
153 DC Characteristic Output Signal Association.....	826
154 DC Output Characteristics.....	828
155 Other DC Characteristics.....	830
156 Clock Timings.....	832
157 PCI Interface Timing.....	834
158 IDE PIO Mode Timings (Mobile Only).....	835
159 IDE Multiword DMA Timings (Mobile Only).....	836
160 Ultra ATA Timing (Mode 0, Mode 1, Mode 2) (Mobile Only).....	836
161 Ultra ATA Timing (Mode 3, Mode 4, Mode 5) (Mobile Only).....	839
162 Universal Serial Bus Timing.....	841
163 SATA Interface Timings.....	842
164 SMBus Timing.....	842
166 LPC Timing.....	843
167 Miscellaneous Timings.....	843
165 Intel® High Definition Audio Timing.....	843
168 SPI Timings (20 MHz).....	844
169 SPI Timings (33 MHz).....	844
170 SST Timings (Desktop Only).....	845
171 PECI Timings (Desktop Only).....	845
172 Power Sequencing and Reset Signal Timings.....	846
173 Power Management Timings.....	848



## Revision History

---

Revision	Description	Date
-001	<ul style="list-style-type: none"><li>Initial release.</li></ul>	June 2006
-002	<ul style="list-style-type: none"><li>Added 82801HDH ICH8 Digital Home (ICH8DH) and 82801HDO ICH8 Digital Office (ICH8DO)</li></ul>	July 2006
-003	<ul style="list-style-type: none"><li>Added Intel® 82801HBM ICH8 Mobile (ICH8M) and Intel® 82801HEM ICH8 Mobile Enhanced (ICH8M-E)</li><li>Added Documentation Changes, Specification Changes, and Specification Clarifications from Specification Update, Rev -008.</li></ul>	May 2007
-004	<ul style="list-style-type: none"><li>Added additional data for IRQ14 and IRQ15.</li></ul>	May 2014

§ §





# Intel® ICH8 Features

---

- Direct Media Interface
  - 10 Gb/s each direction, full duplex
  - Transparent to software
- PCI Express\*
  - 6 PCI Express root ports
  - Supports PCI Express 1.1
  - Ports 1-4 can be statically configured as four x1 or one x4
  - Support for full 2.5 Gb/s bandwidth in each direction per x1 lane
  - Module based Hot-Plug supported (e.g., ExpressCard\*)
- PCI Bus Interface
  - Supports PCI Rev 2.3 Specification at 33 MHz
  - Four available PCI REQ/GNT pairs
  - Support for 64-bit addressing on PCI using DAC protocol
- Integrated Serial ATA Host Controller
  - NEW: Up to six SATA ports (Mobile has 3 ports)
  - NEW: External SATA support (Desktop Only)
  - Data transfer rates up to 3.0 Gb/s (300 MB/s).
  - Integrated AHCI controller
- Intel® Matrix Storage Technology (ICH8R, ICH8DH, ICH8DO, ICH8M-E only)
  - Configures the ICH8 SATA controller as a RAID controller supporting RAID 0/1/5/10 in the ICH8R, ICH8DH, ICH8DO, and supporting Raid 0/1 in the ICH8M-E
- Integrated IDE Controller (Mobile only)
  - Independent timing of up to two drives
  - Ultra ATA/100/66/33, BMIDE and PIO modes
  - Tri-state modes to enable swap bay
- NEW: Intel® Active Management Technology with System Defense (ICH8DO and ICH8M-E only)
- Intel® High Definition Audio Interface
  - PCI Express endpoint
  - Independent Bus Master logic for eight general purpose streams: four input and four output
  - Support four external Codecs
  - Supports variable length stream slots
  - Supports multichannel, 32-bit sample depth, 192 kHz sample rate output
  - Provides mic array support
  - Allows for non-48 kHz sampling output
  - Support for ACPI Device States
  - Low Voltage Mode
  - Docking Support (Mobile only)
- NEW: Intel® Quiet System Technology (Desktop Only)
  - Four TACH signals and three PWM signals
- NEW: Simple Serial Transport (SST) Bus and Platform Environmental Control Interface (PECI) (Desktop Only)
- USB 2.0
  - NEW: up to five UHCI Host Controllers, supporting ten external ports
  - NEW: up to two EHCI Host Controllers that supports ten ports
  - NEW: Includes up to two USB 2.0 High-speed Debug Ports
  - Supports wake-up from sleeping states S1–S5
  - Supports legacy Keyboard/Mouse software
- NEW: Integrated Gigabit LAN Controller
  - Integrated ASF Management Controller
  - NEW: Network security with System Defense
  - Supports IEEE 802.3
  - LAN Connect Interface (LCI) and new Gigabit LAN Connect Interface (GLCI)
  - 10/100/1000 Mb/s Ethernet Support

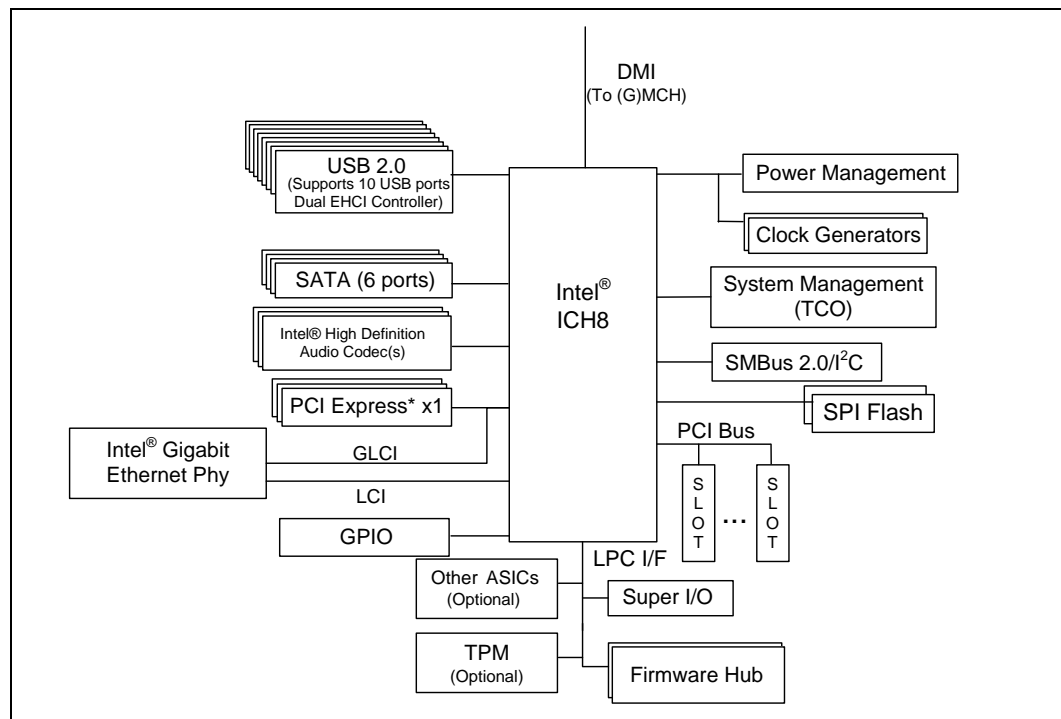


- Power Management Logic
  - Supports ACPI 3.0
  - ACPI-defined power states (C1, S1, S3–S5 for Desktop and C1–C4, S1, S3–S5 for Mobile)
  - ACPI Power Management Timer
  - (Mobile Only) Support for “Intel SpeedStep® Technology” processor power control and “Deeper Sleep” power state
  - PCI CLKRUN# (Mobile only) and PME# support
  - SMI# generation
  - All registers readable/restorable for proper resume from 0 V suspend states
- External Glue Integration
  - Integrated Pull-up, Pull-down and Series Termination resistors on IDE (Mobile only), processor interface
  - Integrated Pull-down and Series resistors on USB
- SMBus
  - NEW: faster speed, up to 100 kbps
  - Flexible SMBus/SMLINK architecture to optimize for ASF
  - Provides independent manageable bus through SMLink interface
  - Supports SMBus 2.0 Specification
  - Host interface allows processor to communicate via SMBus
  - Slave interface allows an internal or external Microcontroller to access system resources
  - Compatible with most two-wire components that are also I<sup>2</sup>C compatible
- High Precision Event Timers
  - Advanced operating system interrupt scheduling
- Timers Based on 82C54
  - System timer, Refresh request, Speaker tone output
- Real-Time Clock
  - 256-byte battery-backed CMOS RAM
  - Integrated oscillator components
  - Lower Power DC/DC Converter implementation
- System TCO Reduction Circuits
  - Timers to generate SMI# and Reset upon detection of system hang
  - Timers to detect improper processor reset
  - Integrated processor frequency strap logic
  - Supports ability to disable external devices
- Enhanced DMA Controller
  - Two cascaded 8237 DMA controllers
  - Supports LPC DMA
- Interrupt Controller
  - Supports up to eight PCI interrupt pins
  - Supports PCI 2.3 Message Signaled Interrupts
  - Two cascaded 82C59 with 15 interrupts
  - Integrated I/O APIC capability with 24 interrupts
  - Supports Processor System Bus interrupt delivery
- 1.05 V operation with 1.5 V and 3.3 V I/O
  - 5 V tolerant buffers on IDE (Mobile only), PCI, USB, and selected Legacy signals
- 1.05 V Core Voltage
  - NEW: Five Integrated Voltage Regulators for different power rails
- Firmware Hub I/F supports BIOS Memory size up to 8 MB
- Serial Peripheral Interface (SPI)
  - NEW: supports up to two SPI devices
  - NEW: supports 20 MHz and 33 MHz SPI devices
- Low Pin Count (LPC) I/F
  - Supports two Master/DMA devices.
  - Support for Security Device (Trusted Platform Module) connected to LPC.
- GPIO
  - TTL, Open-Drain, Inversion
- Package
  - 31x31 mm 652 mBGA (Desktop Only)
  - 31x31 mm 676 mBGA (Mobile Only)

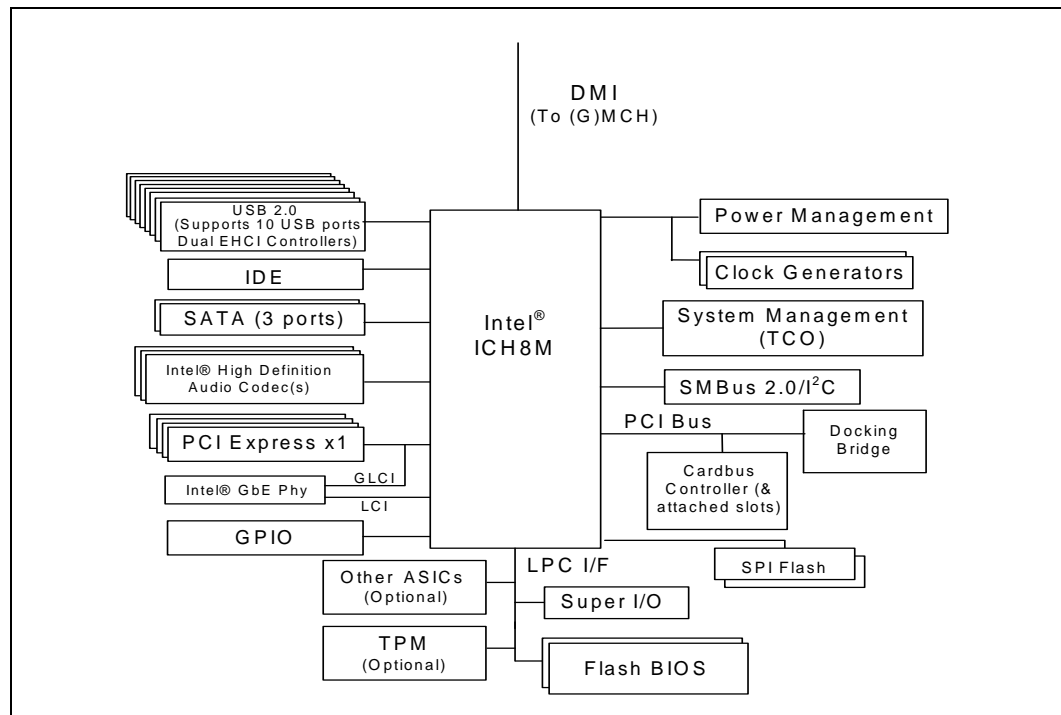
**Note:** Not all features are available on all ICH8 components. See [Section 1.2](#) for more details.



## Desktop Configuration



## Mobile Configuration



§ § §





# 1 Introduction

This document is intended for Original Equipment Manufacturers and BIOS vendors creating Intel® I/O Controller Hub 8 (ICH8) Family based products. This document is the datasheet for the following:

- Intel® 82801HB ICH8 (ICH8)
- Intel® 82801HR ICH8 RAID (ICH8R)
- Intel® 82801HDH ICH8 Digital Home (ICH8DH)
- Intel® 82801HDO ICH8 Digital Office (ICH8DO)
- Intel® 82801HBM ICH8 Mobile (ICH8M)
- Intel® 82801HEM ICH8 Mobile Enhanced (ICH8M-E)

Section 1.2 provides high-level feature differences for the ICH8 Family components.

**Note:** Throughout this datasheet, ICH8 is used as a general ICH8 term and refers to the 82801HB ICH8 and 82801HR ICH8R 82801HDH ICH8DH, 82801HDO ICH8DO, 82801HBM ICH8M, and 82801HEM ICH8M-E components, unless specifically noted otherwise.

**Note:** Throughout this datasheet, the term “Desktop” refers to any implementation, be it in a desktop, server, workstation, etc., unless specifically noted otherwise.

**Note:** Throughout this datasheet, the term “Desktop Only” refers to information that is for the 82801HB ICH8, 82801HR ICH8R, 82801HDH ICH8DH, and 82801HDO ICH8DO unless specifically noted otherwise. The term “Digital Home Only” refers to information that is for the 82801HDH ICH8DH, unless specifically noted otherwise. The term “Digital Office Only” refers to information that is for the 82801HDO ICH8DO, unless specifically noted otherwise. The term “Mobile Only” refers to information that is for both the 82801HBM ICH8M and 82801HEM ICH8M-E, unless noted otherwise.

This datasheet is intended for Original Equipment Manufacturers and BIOS vendors creating Intel® ICH8 family-based products. This manual assumes a working knowledge of the vocabulary and principles of PCI Express\*, USB, IDE (Mobile Only), AHCI, SATA, Intel® High Definition Audio (Intel® HD Audio), SMBus, PCI, ACPI and LPC. Although some details of these features are described within this manual, refer to the individual industry specifications listed in Table 1 for the complete details.

**Table 1. Industry Specifications**

Specification	Location
Intel® I/O Controller Hub 8 (ICH8) Family Specification Update	<a href="http://www.intel.com/design/chipsets/specupdt/313057.htm">http://www.intel.com/design/chipsets/specupdt/313057.htm</a>
PCI Express* Base Specification, Revision 1.1	<a href="http://www.pcisig.com/specifications">http://www.pcisig.com/specifications</a>
Low Pin Count Interface Specification, Revision 1.1 (LPC)	<a href="http://developer.intel.com/design/chipsets/industry/lpc.htm">http://developer.intel.com/design/chipsets/industry/lpc.htm</a>
System Management Bus Specification, Version 2.0 (SMBus)	<a href="http://www.smbus.org/specs/">http://www.smbus.org/specs/</a>
PCI Local Bus Specification, Revision 2.3 (PCI)	<a href="http://www.pcisig.com/specifications">http://www.pcisig.com/specifications</a>
PCI Mobile Design Guide, Revision 1.1	<a href="http://www.pcisig.com/specifications">http://www.pcisig.com/specifications</a>
PCI Power Management Specification, Revision 1.1	<a href="http://www.pcisig.com/specifications">http://www.pcisig.com/specifications</a>

**Table 1. Industry Specifications**

Specification	Location
Universal Serial Bus Specification (USB), Revision 2.0	<a href="http://www.usb.org/developers/docs">http://www.usb.org/developers/docs</a>
Advanced Configuration and Power Interface, Version 2.0 (ACPI)	<a href="http://www.acpi.info/spec.htm">http://www.acpi.info/spec.htm</a>
Universal Host Controller Interface, Revision 1.1 (UHCI)	<a href="http://developer.intel.com/design/USB/UHCI11D.htm">http://developer.intel.com/design/USB/UHCI11D.htm</a>
Enhanced Host Controller Interface Specification for Universal Serial Bus, Revision 1.0 (EHCI)	<a href="http://developer.intel.com/technology/usb/ehcispec.htm">http://developer.intel.com/technology/usb/ehcispec.htm</a>
Serial ATA Specification, Revision 2.5	<a href="http://www.serialata.org/specifications.asp">http://www.serialata.org/specifications.asp</a>
Alert Standard Format Specification, Version 1.03	<a href="http://www.dmtf.org/standards/asf">http://www.dmtf.org/standards/asf</a>
IEEE 802.3 Fast Ethernet	<a href="http://standards.ieee.org/getieee802/">http://standards.ieee.org/getieee802/</a>
ATA Attachment - 6 with Packet Interface (ATA/ATAPI - 6)	<a href="http://T13.org">http://T13.org</a> (T13 1410D)
IA-PC HPET (High Precision Event Timers) Specification, Revision 0.98a	<a href="http://www.intel.com/hardwaredesign/hpetspec.htm">http://www.intel.com/hardwaredesign/hpetspec.htm</a>

### Chapter 1. Introduction

Chapter 1 introduces the ICH8 and provides information on manual organization and gives a general overview of the ICH8.

### Chapter 2. Signal Description

Chapter 2 provides a block diagram of the ICH8 and a detailed description of each signal. Signals are arranged according to interface and details are provided as to the drive characteristics (Input/Output, Open Drain, etc.) of all signals.

### Chapter 3. Intel® ICH8 Pin States

Chapter 3 provides a complete list of signals, their associated power well, their logic level in each suspend state, and their logic level before and after reset.

### Chapter 4. Intel® ICH8 and System Clock Domains

Chapter 4 provides a list of each clock domain associated with the ICH8 in an ICH8 based system.

### Chapter 5. Functional Description

Chapter 5 provides a detailed description of the functions in the ICH8. All PCI buses, devices and functions in this manual are abbreviated using the following nomenclature; Bus:Device:Function. This manual abbreviates buses as B0 and B1, devices as D8, D27, D28, D29, D30 and D31 and functions as F0, F1, F2, F3, F4, F5, F6 and F7. For example Device 31 Function 0 is abbreviated as D31:F0, Bus 1 Device 8 Function 0 is abbreviated as B1:D8:F0. Generally, the bus number will not be used, and can be considered to be Bus 0. Note that the ICH8's external PCI bus is typically Bus 1, but may be assigned a different number depending upon system configuration.

### Chapter 6. Register and Memory Mappings

Chapter 6 provides an overview of the registers, fixed I/O ranges, variable I/O ranges and memory ranges decoded by the ICH8.

### Chapter 7. Chipset Configuration Registers

Chapter 7 provides a detailed description of all registers and base functionality that is related to chipset configuration and not a specific interface (such as LPC, PCI, or PCI Express). It contains the root complex register block, which describes the behavior of the upstream internal link.



### **Chapter 8. Integrated LAN Controller Registers**

[Chapter 8](#) provides a detailed description of all registers that reside in the ICH8's integrated LAN controller. The integrated LAN Controller resides at Device 25, Function 0 (D25:F0).

### **Chapter 9. LPC Bridge Registers**

[Chapter 9](#) provides a detailed description of all registers that reside in the LPC bridge. This bridge resides at Device 31, Function 0 (D31:F0). This function contains registers for many different units within the ICH8 including DMA, Timers, Interrupts, Processor Interface, GPIO, Power Management, System Management and RTC.

### **Chapter 10. PCI-to-PCI Bridge Registers**

[Chapter 10](#) provides a detailed description of all registers that reside in the PCI-to-PCI bridge. This bridge resides at Device 30, Function 0 (D30:F0).

### **Chapter 11. IDE Controller Registers (Mobile Only)**

[Chapter 11](#) provides a detailed description of all registers that reside in the IDE controller. This controller resides at Device 31, Function 1 (D31:F1).

### **Chapter 11. SATA Controller Registers**

[Chapter 12](#) provides a detailed description of all registers that reside in the SATA controller #1. This controller resides at Device 31, Function 2 (D31:F2).

### **Chapter 12. SATA Controller Registers**

[Chapter 13](#) provides a detailed description of all registers that reside in the SATA controller #2. This controller resides at Device 31, Function 5 (D31:F5).

### **Chapter 13. UHCI Controller Registers**

[Chapter 14](#) provides a detailed description of all registers that reside in the five UHCI host controllers. These controllers reside at Device 29, Functions 0, 1, 2, and 3 (D29:F0/F1/F2/F3) and Device 26, Function 1 (D26:F1).

### **Chapter 14. EHCI Controller Registers**

[Chapter 15](#) provides a detailed description of all registers that reside in the EHCI host controllers. This controller resides at Device 29, Function 7 (D29:F7) and Device 26, Function 7 (D26:F7).

### **Chapter 15. SMBus Controller Registers**

[Chapter 16](#) provides a detailed description of all registers that reside in the SMBus controller. This controller resides at Device 31, Function 3 (D31:F3).

### **Chapter 16. Intel® High Definition Audio Controller Registers**

[Chapter 17](#) provides a detailed description of all registers that reside in the Intel High Definition Audio controller. This controller resides at Device 27, Function 0 (D27:F0).

### **Chapter 17. PCI Express\* Port Controller Registers**

[Chapter 18](#) provides a detailed description of all registers that reside in the PCI Express controller. This controller resides at Device 28, Functions 0 to 5 (D30:F0-F5).

### **Chapter 18. High Precision Event Timers Registers**

[Chapter 19](#) provides a detailed description of all registers that reside in the multimedia timer memory mapped register space.

### **Chapter 19. Serial Peripheral Interface Registers**

[Chapter 20](#) provides a detailed description of all registers that reside in the SPI memory mapped register space.

### **Chapter 20. Thermal Sensors**

[Chapter 21](#) provides a detailed description of all registers that reside in the thermal sensors PCI configuration space. The registers reside at Device 31, Function 6 (D31:F6).

**Chapter 21. Ballout Definition**

[Chapter 22](#) provides a table of each signal and its ball assignment in the 652-mBGA package.

**Chapter 22. Electrical Characteristics**

[Chapter 23](#) provides all AC and DC characteristics including detailed timing diagrams.

**Chapter 24. Package Information**

[Chapter 24](#) provides drawings of the physical dimensions and characteristics of the 652-mBGA package.

**Appendix A. Index**

This volume ends with indexes of registers and register bits.

## 1.1 Overview

The ICH8 provides extensive I/O support. Functions and capabilities include:

- *PCI Express\* Base Specification*, Revision 1.1 support
- *PCI Local Bus Specification*, Revision 2.3 support for 33 MHz PCI operations (supports up to four Req/Gnt pairs).
- ACPI Power Management Logic Support
- Enhanced DMA controller, interrupt controller, and timer functions
- Integrated Serial ATA host controllers with independent DMA operation on up to six ports (Desktop only) or three ports (Mobile only) and AHCI support.
- Integrated IDE controller supports Ultra ATA100/66/33 (Mobile only)
- USB host interface with support for up to ten USB ports; five UHCI host controllers; two EHCI high-speed USB 2.0 Host controllers
- Integrated 10/100/1000 GbE MAC with System Defense
- *System Management Bus (SMBus) Specification*, Version 2.0 with additional support for I<sup>2</sup>C devices)
- Supports Intel High Definition Audio
- Supports Intel<sup>®</sup> Matrix Storage Technology (ICH8, ICH8DH, ICH8DO, and ICH8M-E only)
- Supports Intel<sup>®</sup> Active Management Technology (ICH8DO and ICH8M-E only)
- Low Pin Count (LPC) interface
- Firmware Hub (FWH) interface support
- Serial Peripheral Interface (SPI) support
- Intel<sup>®</sup> Quiet System Technology (Desktop only)

The Intel ICH8 incorporates a variety of PCI devices and functions, as shown in [Table 2](#). They are divided into seven logical devices. The first device is the DMI-To-PCI bridge (Device 30). The second device (Device 31) contains most of the standard PCI functions that have existed in legacy PCI-to-ISA bridges (South Bridges). The third and fourth devices (Device 29 and Device 26) are the USB host controller devices. The fifth device (Device 28) is PCI Express device. The sixth device (Device 27) is the Intel HD Audio controller device, and the seventh device (Device 25) is the GbE controller device.





Table 2. PCI Devices and Functions

Bus:Device:Function	Function Description
Bus 0: Device 30: Function 0	PCI-to-PCI Bridge
Bus 0: Device 31: Function 0	LPC Controller <sup>1</sup>
Bus 0: Device 31: Function 1	IDE Controller (Mobile only)
Bus 0: Device 31: Function 2	SATA Controller 1
Bus 0: Device 31: Function 5	SATA Controller 2
Bus 0: Device 31: Function 6	Thermal Subsystem
Bus 0: Device 31: Function 3	SMBus Controller
Bus 0: Device 29: Function 0	USB FS/LS UHCI Controller 1
Bus 0: Device 29: Function 1	USB FS/LS UHCI Controller 2
Bus 0: Device 29: Function 2	USB FS/LS UHCI Controller 3
Bus 0: Device 29: Function 7	USB HS EHCI Controller 1
Bus 0: Device 26: Function 0	USB FS/LS UHCI Controller 4
Bus 0: Device 26: Function 1	USB FS/LS UHCI Controller 5
Bus 0: Device 26: Function 7	USB HS EHCI Controller 2
Bus 0: Device 28: Function 0	PCI Express* Port 1
Bus 0: Device 28: Function 1	PCI Express Port 2
Bus 0: Device 28: Function 2	PCI Express Port 3
Bus 0: Device 28: Function 3	PCI Express Port 4
Bus 0: Device 28: Function 4	PCI Express Port 5
Bus 0: Device 28: Function 5	PCI Express Port 6
Bus 0: Device 27: Function 0	Intel <sup>®</sup> High Definition Audio Controller
Bus 0: Device 25: Function 0	GbE Controller

**NOTES:**

1. The PCI-to-LPC bridge contains registers that control LPC, Power Management, System Management, GPIO, Processor Interface, RTC, Interrupts, Timers, and DMA.

The following sub-sections provide an overview of ICH8 capabilities.

**Direct Media Interface (DMI)**

Direct Media Interface (DMI) is the chip-to-chip connection between the Memory Controller Hub / Graphics Memory Controller Hub ((G)MCH) and I/O Controller Hub 8 (ICH8). This high-speed interface integrates advanced priority-based servicing allowing for concurrent traffic and true isochronous transfer capabilities. Base functionality is completely software-transparent, permitting current and legacy software to operate normally.

**PCI Express\* Interface**

The ICH8 provides up to 6 PCI Express Root Ports, supporting the *PCI Express Base Specification*, Revision 1.1. Each Root Port supports 2.5 Gb/s bandwidth in each direction (5 Gb/s concurrent). PCI Express Root Ports 1–4 can be statically configured as four x1 Ports or ganged together to form one x4 port. Ports 5 and 6 can only be used as two x1 ports. On Mobile platforms, PCI Express Ports 1–4 can also be configured as one x2 port (using ports 1 and 2) with ports 3 and 4 configured as x1 ports.



**Note:** The integrated GbE controllers data lines for 1000 Mb/s speed are multiplexed with PCI Express\* Root Port 6 and, therefore, unavailable if a Gigabit Ethernet PHY is connected. The use of a 10/100 Mb/s PHY does not consume PCI Express Root Port 6 and, therefore, the port is available to be used as a x1 port.

### Serial ATA (SATA) Controller

The ICH8 has integrated SATA host controllers that supports independent DMA operation on up to six ports (desktop only) or three ports (mobile only) and supports data transfer rates of up to 3.0 Gb/s (300 MB/s). The SATA controller contains two modes of operation – a legacy mode using I/O space, and an AHCI mode using memory space. SATA and PATA (Mobile only) can also be used in a combined function mode (where the SATA function is used with PATA). In this combined function mode, AHCI mode is not used. Software that uses legacy mode will not have AHCI capabilities.

The ICH8 supports the *Serial ATA Specification*, Revision 2.5. The ICH8 also supports several optional sections of the Serial ATA II: Extensions to *Serial ATA 1.0 Specification*, Revision 1.0 (AHCI support is required for some elements).

**Note:** SATA Ports 2 and 3 are not on the ICH8 Base product. See [Section 1.2](#) for details on product feature availability.

### AHCI

The ICH8 provides hardware support for Advanced Host Controller Interface (AHCI), a new programming interface for SATA host controllers. Platforms supporting AHCI may take advantage of performance features such as no master/slave designation for SATA devices—each device is treated as a master—and hardware-assisted native command queuing. AHCI also provides usability enhancements such as Hot-Plug. AHCI requires appropriate software support (e.g., an AHCI driver) and for some features, hardware support in the SATA device or additional platform hardware.

### Intel Matrix Storage Technology (Intel® ICH8R, ICH8DH, ICH8DO, and ICH8M-E Only)

The ICH8 provides support for Intel Matrix Storage Technology, providing both AHCI (see above for details on AHCI) and integrated RAID functionality. The industry-leading RAID capability provides high-performance RAID 0, 1, 5, and 10 functionality on up to 6 SATA ports of ICH8. Matrix RAID support is provided to allow multiple RAID levels to be combined on a single set of hard drives, such as RAID 0 and RAID 1 on two disks. Other RAID features include hot spare support, SMART alerting, and RAID 0 auto replace. Software components include an Option ROM for pre-boot configuration and boot functionality, a Microsoft Windows compatible driver, and a user interface for configuration and management of the RAID capability of ICH8. Note that ICH8M-E supports only RAID 0 and RAID 1.

### PCI Interface

The ICH8 PCI interface provides a 33 MHz, Revision 2.3 implementation. The ICH8 integrates a PCI arbiter that supports up to four external PCI bus masters in addition to the internal ICH8 requests. This allows for combinations of up to four PCI down devices and PCI slots.



## IDE Interface (Bus Master Capability and Synchronous DMA Mode) (Mobile Only)

The fast IDE interface supports up to two IDE devices providing an interface for IDE hard disks and ATAPI devices. Each IDE device can have independent timings. The IDE interface supports PIO IDE transfers up to 16 MB/sec and Ultra ATA transfers up to 100 MB/sec. It does not consume any legacy DMA resources. The IDE interface integrates 16x32-bit buffers for optimal transfers.

The ICH8's IDE system contains a single, independent IDE signal channel that can be electrically isolated. There are integrated series resistors on the data and control lines (see [Section 5.17](#) for details). See [Section 1.2](#) for details on component feature availability.

## Low Pin Count (LPC) Interface

The ICH8 implements an LPC Interface as described in the *LPC 1.1 Specification*. The Low Pin Count (LPC) bridge function of the ICH8 resides in PCI Device 31:Function 0. In addition to the LPC bridge interface function, D31:F0 contains other functional units including DMA, interrupt controllers, timers, power management, system management, GPIO, and RTC.

## Serial Peripheral Interface (SPI)

The ICH8 implements an SPI Interface as an alternative interface for the BIOS flash device. An SPI flash device can be used as a replacement for the FWH, and is required to support Intel Active Management Technology (ICH8DO and ICH8M-E only) and the integrated Fan Speed Control (Intel® Quiet System Technology) (Desktop only). The ICH8 supports up to two SPI flash devices with speeds up to 33 MHz using two chip select pins.

## Compatibility Modules (DMA Controller, Timer/Counters, Interrupt Controller)

The DMA controller incorporates the logic of two 82C37 DMA controllers, with seven independently programmable channels. Channels 0–3 are hardwired to 8-bit, count-by-byte transfers, and channels 5–7 are hardwired to 16-bit, count-by-word transfers. Any two of the seven DMA channels can be programmed to support fast Type-F transfers.

The ICH8 supports LPC DMA, which is similar to ISA DMA, through the ICH8's DMA controller. LPC DMA is handled through the use of the LDRQ# lines from peripherals and special encoding on LAD[3:0] from the host. Single, Demand, Verify, and Increment modes are supported on the LPC interface. Channels 0–3 are 8-bit channels. Channels 5–7 are 16-bit channels. Channel 4 is reserved as a generic bus master request.

The timer/counter block contains three counters that are equivalent in function to those found in one 82C54 programmable interval timer. These three counters are combined to provide the system timer function, and speaker tone. The 14.31818 MHz oscillator input provides the clock source for these three counters.

The ICH8 provides an ISA-Compatible Programmable Interrupt Controller (PIC) that incorporates the functionality of two, 82C59 interrupt controllers. The two interrupt controllers are cascaded so that 14 external and two internal interrupts are possible. In addition, the ICH8 supports a serial interrupt scheme.

All of the registers in these modules can be read and restored. This is required to save and restore system state after power has been removed and restored to the platform.



## Advanced Programmable Interrupt Controller (APIC)

In addition to the standard ISA compatible Programmable Interrupt controller (PIC) described in the previous section, the ICH8 incorporates the Advanced Programmable Interrupt Controller (APIC).

## Universal Serial Bus (USB) Controllers

The ICH8 contains up to two Enhanced Host Controller Interface (EHCI) host controllers that support USB high-speed signaling. High-speed USB 2.0 allows data transfers up to 480 Mb/s which is 40 times faster than full-speed USB. The ICH8 also contains up to five Universal Host Controller Interface (UHCI) controllers that support USB full-speed and low-speed signaling.

The ICH8 supports up to ten USB 2.0 ports. All ten ports are high-speed, full-speed, and low-speed capable. ICH8's port-routing logic determines whether a USB port is controlled by one of the UHCI or EHCI controllers. See [Section 5.18](#) and [Section 5.19](#) for details.

## Gigabit Ethernet Controller

The Gigabit Ethernet Controller provides a system interface via a PCI function. The controller provides a full memory-mapped or IO mapped interface along with a 64 bit address master support for systems using more than 4 GB of physical memory and DMA (Direct Memory Addressing) mechanisms for high performance data transfers. Its bus master capabilities enable the component to process high-level commands and perform multiple operations; this lowers processor utilization by off-loading communication tasks from the processor. Two large configurable transmit and receive FIFOs (up to 16 KB each) help prevent data underruns and overruns while waiting for bus accesses. This enables the integrated LAN controller to transmit data with minimum interframe spacing (IFS).

The LAN controller can operate at multiple speeds (10/100/1000 Mb/s) and in either full duplex or half duplex mode. In full duplex mode the LAN controller adheres with the *IEEE 802.3x Flow Control* Specification. Half duplex performance is enhanced by a proprietary collision reduction mechanism. See [Section 5.3](#) for details.

## RTC

The ICH8 contains a Motorola MC146818A-compatible real-time clock with 256 bytes of battery-backed RAM. The real-time clock performs two key functions: keeping track of the time of day and storing system data, even when the system is powered down. The RTC operates on a 32.768 KHz crystal and a 3 V battery.

The RTC also supports two lockable memory ranges. By setting bits in the configuration space, two 8-byte ranges can be locked to read and write accesses. This prevents unauthorized reading of passwords or other system security information.

The RTC also supports a date alarm that allows for scheduling a wake up event up to 30 days in advance, rather than just 24 hours in advance.

## GPIO

Various general purpose inputs and outputs are provided for custom system design. The number of inputs and outputs varies depending on ICH8 configuration.



## Enhanced Power Management

The ICH8's power management functions include enhanced clock control and various low-power (suspend) states (e.g., Suspend-to-RAM and Suspend-to-Disk). A hardware-based thermal management circuit permits software-independent entrance to low-power states. The ICH8 contains full support for the *Advanced Configuration and Power Interface (ACPI) Specification, Revision 2.0*.

### Intel® Quick Resume Technology (QRT) (Intel® ICH8DH Only)

ICH8DH implements Intel Quick Resume Technology (QRT) to give the PC a Consumer Electronics device-like feel. Intel QRT provides the capability to design a PC with a single power button that reliably and instantly (user's perception) turns the PC On and Off. When the system is On and the user presses the power button, the display instantly goes dark, sound is muted, and there is no response to keyboard/mouse commands (except for keyboard power button). When the system is Off and the user presses the power button, picture and sound quickly return, and the keyboard/mouse return to normal functionality, allowing user input.

### Intel® Active Management Technology (Intel® AMT) (Intel® ICH8DO and ICH8M-E Only)

Intel Active Management Technology is the next generation of client manageability via the wired network. Intel AMT is a set of advanced manageability features developed as a direct result of IT customer feedback gained through Intel market research. With the new implementation of System Defense in ICH8, the advanced manageability feature set of Intel AMT is further enhanced.

## Manageability

In addition to Intel AMT the ICH8 integrates several functions designed to manage the system and lower the total cost of ownership (TCO) of the system. These system management functions are designed to report errors, diagnose the system, and recover from system lockups without the aid of an external microcontroller.

- **TCO Timer.** The ICH8's integrated programmable TCO timer is used to detect system locks. The first expiration of the timer generates an SMI# that the system can use to recover from a software lock. The second expiration of the timer causes a system reset to recover from a hardware lock.
- **Processor Present Indicator.** The ICH8 looks for the processor to fetch the first instruction after reset. If the processor does not fetch the first instruction, the ICH8 will reboot the system.
- **ECC Error Reporting.** When detecting an ECC error, the host controller has the ability to send one of several messages to the ICH8. The host controller can instruct the ICH8 to generate either an SMI#, NMI, SERR#, or TCO interrupt.
- **Function Disable.** The ICH8 provides the ability to disable the following integrated functions: IDE, LAN, USB, LPC, Intel HD Audio, SATA, or SMBus. Once disabled, these functions no longer decode I/O, memory, or PCI configuration space. Also, no interrupts or power management events are generated from the disabled functions.
- **Intruder Detect.** The ICH8 provides an input signal (INTRUDER#) that can be attached to a switch that is activated by the system case being opened. The ICH8 can be programmed to generate an SMI# or TCO interrupt due to an active INTRUDER# signal.

**Note:** ASF functionality with the integrated ICH8 ASF controller requires a correctly configured system, including an appropriate (G)MCH with ME, ME Firmware, system BIOS support, and appropriate Platform LAN Connect Device.



## System Management Bus (SMBus 2.0)

The ICH8 contains an SMBus Host interface that allows the processor to communicate with SMBus slaves. This interface is compatible with most I<sup>2</sup>C devices. Special I<sup>2</sup>C commands are implemented.

The ICH8's SMBus host controller provides a mechanism for the processor to initiate communications with SMBus peripherals (slaves). Also, the ICH8 supports slave functionality, including the Host Notify protocol. Hence, the host controller supports eight command protocols of the SMBus interface (see *System Management Bus (SMBus) Specification, Version 2.0*): Quick Command, Send Byte, Receive Byte, Write Byte/Word, Read Byte/Word, Process Call, Block Read/Write, and Host Notify.

ICH8's SMBus also implements hardware-based Packet Error Checking for data robustness and the Address Resolution Protocol (ARP) to dynamically provide address to all SMBus devices.

## Intel® High Definition Audio Controller

The *Intel® High Definition Audio Specification* defines a digital interface that can be used to attach different types of codecs, such as audio and modem codecs. The ICH8 Intel HD Audio controller supports up to 4 codecs. The link can operate at either 3.3 V or 1.5 V.

With the support of multi-channel audio stream, 32-bit sample depth, and sample rate up to 192 kHz, the Intel HD Audio controller provides audio quality that can deliver CE levels of audio experience. On the input side, the ICH8 adds support for an array of microphones.

## Intel® Quiet System Technology (Desktop Only)

The ICH8 integrates four fan speed sensors (four TACH signals) and 3 fan speed controllers (three Pulse Width Modulator (PWM) signals), which enables monitoring and controlling up to four fans on the system. With the new implementation of the single-wire Simple Serial Transport (SST) bus and Platform Environmental Control Interface (PECI), the ICH8 provides an easy way to connect to SST-based thermal sensors and access the processor thermal data. In addition, coupled with the new sophisticated Intel® Quiet System Technology algorithms, the ICH8 integrated fan speed control provides effective thermal and acoustic management for the platform.

**Note:** Intel® Quiet System Technology functionality requires a correctly configured system, including an appropriate (G)MCH with ME, ME Firmware, and system BIOS support.



## 1.2 Intel® ICH8 Family High-Level Component Differences

**Table 3. Intel® ICH8 Desktop/Server Family**

Product Name	Short Name	SATA Ports (#)	Intel® Matrix Storage Technology
ICH8 Base	ICH8	4	No
ICH8 RAID	ICH8R	6	Yes
ICH8 Digital Home	ICH8DH	6	Yes
ICH8 Digital Office	ICH8DO	6	Yes

**NOTES:**

1. Table above shows feature differences between ICH8 family components. If a feature is not listed in the table it is considered a Base feature that is included in all family components.
2. Product feature capability can be read in D31:F0, Offset E4h.
3. SATA Ports 2 and 3 are not available in the Desktop ICH8 Base component.

**Table 4. Intel® ICH8 Mobile Family**

Product Name	Short Name	SATA Ports (#)	Intel® Matrix Storage Technology RAID 0/1 Support	Intel® Active Management Technology
ICH8M Base	ICH8M	3	No	No
ICH8M Enhanced	ICH8M-E	3	Yes	Yes

**NOTES:**

1. Table above shows feature differences between ICH8 family components. If a feature is not listed in the table it is considered a Base feature that is included in all family components.
2. Product feature capability can be read in D31:F0:Offset E4h.

§ §







## 2 Signal Description

---

This chapter provides a detailed description of each signal. The signals are arranged in functional groups according to their associated interface.

The “#” symbol at the end of the signal name indicates that the active, or asserted state occurs when the signal is at a low voltage level. When “#” is not present, the signal is asserted when at the high voltage level.

The following notations are used to describe the signal type:

<b>I</b>	Input Pin
<b>O</b>	Output Pin
<b>OD O</b>	Open Drain Output Pin.
<b>I/OD</b>	Bi-directional Input/Open Drain Output Pin.
<b>I/O</b>	Bi-directional Input / Output Pin.
<b>OC</b>	Open Collector Output Pin.

Figure 1. Intel® ICH8 Interface Signals Block Diagram (Desktop)

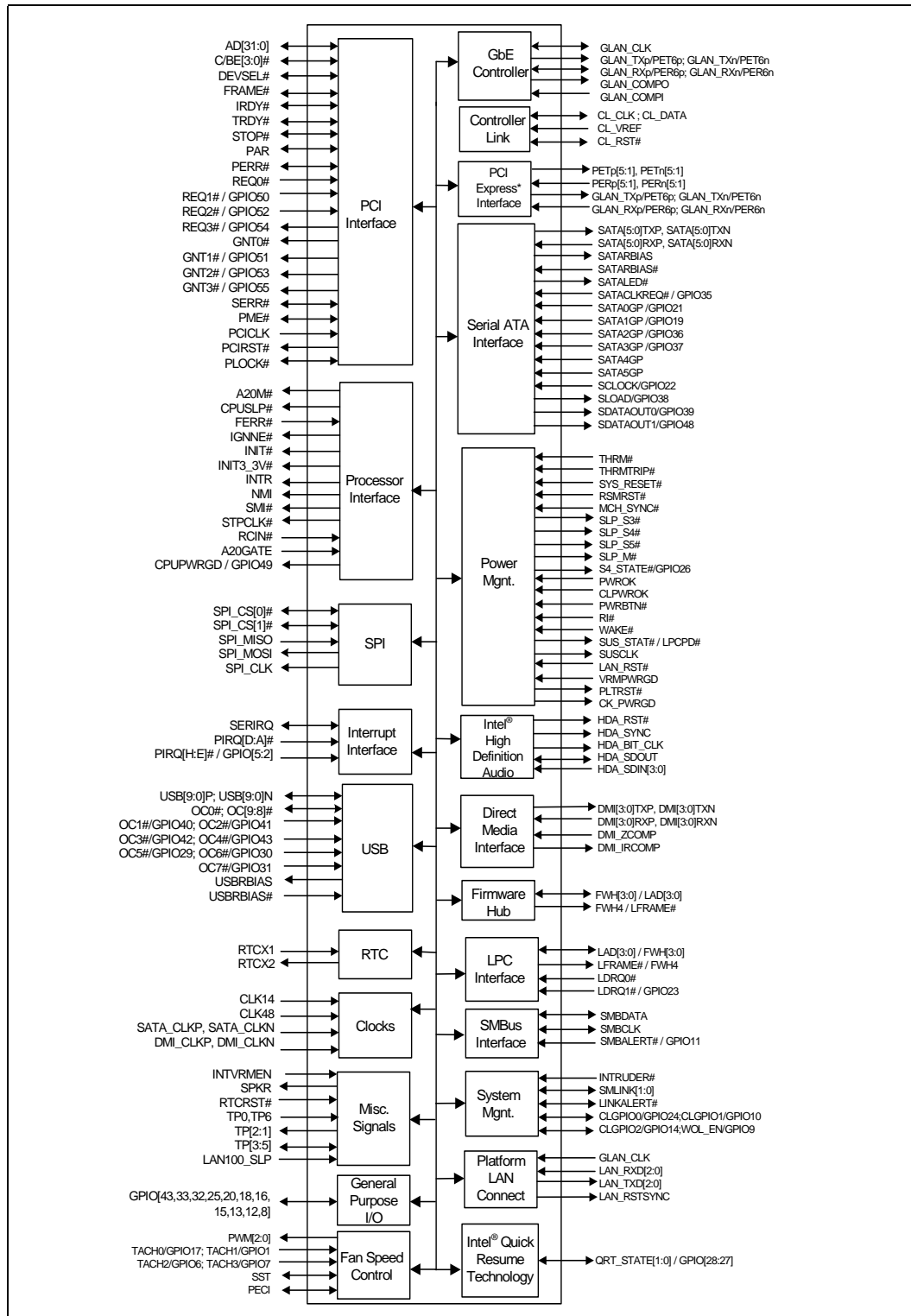
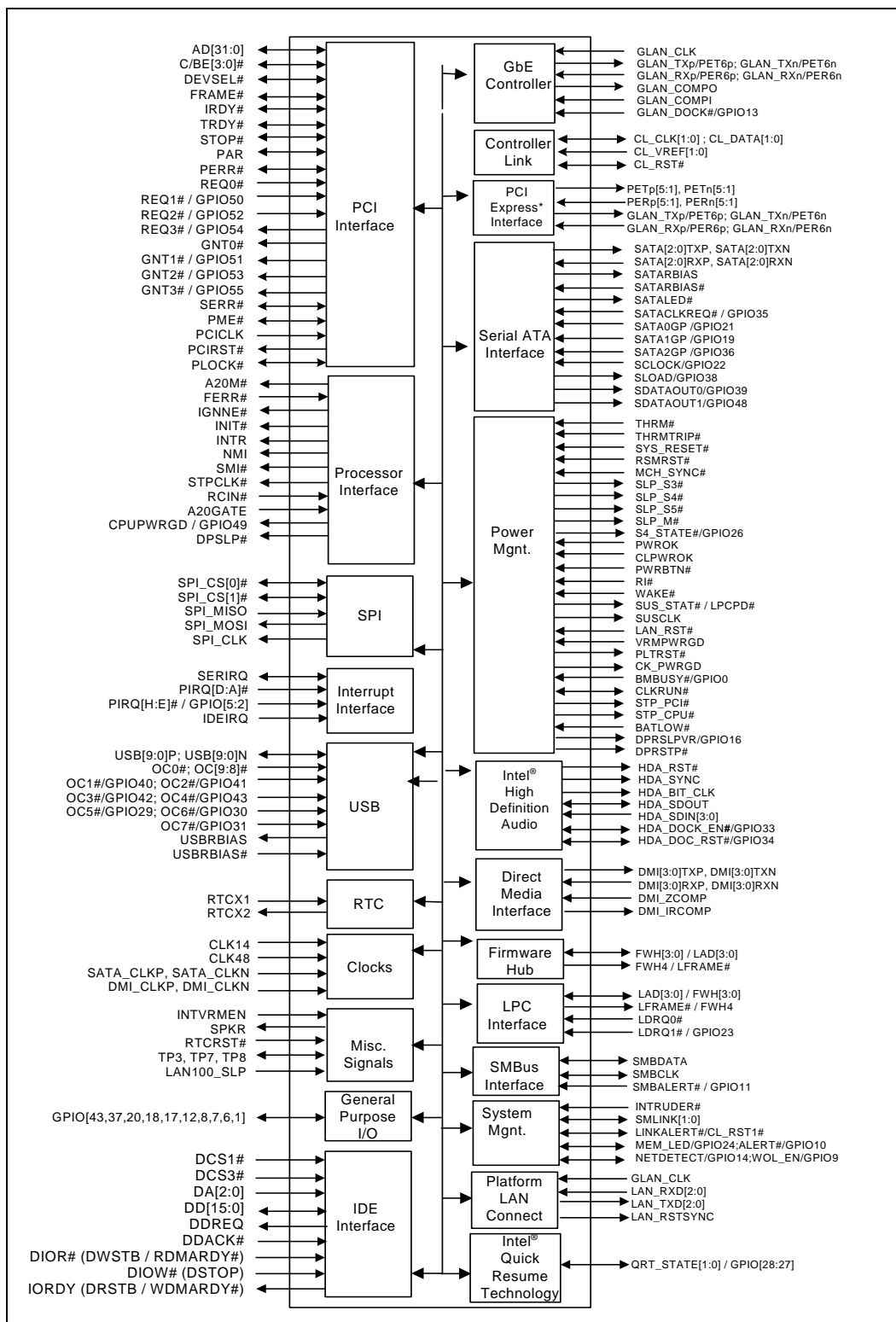




Figure 2. Intel® ICH8 Interface Signals Block Diagram (Mobile)



## 2.1 Direct Media Interface (DMI) to Host Controller

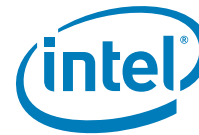
Table 5. Direct Media Interface Signals

Name	Type	Description
DMI0TXP, DMI0TXN	0	Direct Media Interface Differential Transmit Pair 0
DMI0RXP, DMI0RXN	1	Direct Media Interface Differential Receive Pair 0
DMI1TXP, DMI1TXN	0	Direct Media Interface Differential Transmit Pair 1
DMI1RXP, DMI1RXN	1	Direct Media Interface Differential Receive Pair 1
DMI2TXP, DMI2TXN	0	Direct Media Interface Differential Transmit Pair 2
DMI2RXP, DMI2RXN	1	Direct Media Interface Differential Receive Pair 2
DMI3TXP, DMI3TXN	0	Direct Media Interface Differential Transmit Pair 3
DMI3RXP, DMI3RXN	1	Direct Media Interface Differential Receive Pair 3
DMI_ZCOMP	1	<b>Impedance Compensation Input:</b> This signal determines DMI input impedance.
DMI_IRCOMP	0	<b>Impedance/Current Compensation Output:</b> This signal determines DMI output impedance and bias current.

## 2.2 PCI Express\*

Table 6. PCI Express\* Signals

Name	Type	Description
PETp1, PETn1	0	PCI Express* Differential Transmit Pair 1
PERp1, PERn1	1	PCI Express Differential Receive Pair 1
PETp2, PETn2	0	PCI Express Differential Transmit Pair 2
PERp2, PERn2	1	PCI Express Differential Receive Pair 2
PETp3, PETn3	0	PCI Express Differential Transmit Pair 3
PERp3, PERn3	1	PCI Express Differential Receive Pair 3
PETp4, PETn4	0	PCI Express Differential Transmit Pair 4
PERp4, PERn4	1	PCI Express Differential Receive Pair 4
PETp5, PETn5	0	PCI Express Differential Transmit Pair 5
PERp5, PERn5	1	PCI Express Differential Receive Pair 5
PETp6/GLAN_TXp, PETn6/GLAN_TXn	0	<b>PCI Express Differential Transmit Pair 6:</b> The differential pair functions as the GbE LAN transmit pair when the integrated GbE controller is enabled.
PERp6/GLAN_RXp, PERn6/GLAN_RXn	1	<b>PCI Express Differential Receive Pair 6:</b> The differential pair functions as the GbE LAN receive pair when the integrated GbE controller is enabled.



## 2.3 LAN Connect Interface

Table 7. LAN Connect Interface Signals

Name	Type	Description
GLAN_CLK	I	<b>GbE Input Clock:</b> This clock is driven by LAN Connect Device. The frequency will vary depending on link speed. <b>NOTE:</b> The clock is shared between LAN Connect Interface and Gigabit LAN Connect Interface.
LAN_RXD[2:0]	I	<b>Received Data:</b> The Platform LAN Connect component uses these signals to transfer data and control information to the integrated LAN controller. These signals have integrated weak pull-up resistors.
LAN_TXD[2:0]	O	<b>Transmit Data:</b> The integrated LAN controller uses these signals to transfer data and control information to the Platform LAN Connect device.
LAN_RSTSYNC	O	<b>LAN Reset/Sync:</b> The LAN Connect component's Reset and Sync signals are multiplexed onto this pin.

## 2.4 Gigabit LAN Connect Interface

Table 8. Gigabit LAN Connect Interface Signals

Name	Type	Description
GLAN_CLK	I	<b>GbE Input Clock:</b> Clock driven by LAN Connect Device. The frequency will vary depending on link speed. <b>NOTE:</b> The clock is shared between LAN Connect Interface and Gigabit LAN Connect Interface.
GLAN_TXp/PET6p; GLAN_TXn/PET6n	O	<b>Gigabit LAN Differential Transmit Pair:</b> These signals can, instead, be used as PCI Express port 6 differential transmit pair
GLAN_RXp/PER6p; GLAN_RXn/PER6n	I	<b>Gigabit LAN Differential Receive Pair:</b> These signals can, instead, be used as PCI Express port 6 differential receive pair.
GLAN_COMPO	O	<b>Impedance Compensation Output pad:</b> Determines Gigabit LAN Connect Interface output impedance and bias current.
GLAN_COMPI	I	<b>Impedance Compensation Input pad:</b> Determines Gigabit LAN Connect Interface input impedance.
GLAN_DOCK# (Mobile Only)/ GPIO12	I	<b>GbE Dock/Undock Indication:</b> This signal Indicates if the platform is in docked or undocked position. The platform should drive this pin low or high depending on its docked or undocked state. This signal is configured via soft straps as described in <a href="#">Section 20.2.5.1</a> . This signal may instead be used as a GPIO.

**Table 8. Gigabit LAN Connect Interface Signals**

Name	Type	Description
ENERGY_DETECT (Mobile Only) / GPIO13	I	<b>Energy Detect (Mobile Only):</b> This input detect signal indicates that power to the LAN Connected Device must be restored. This signal connects to the output of an external link detect circuit and is required to implement the Intel® Auto Detect Battery Saver feature for LAN Connect Device Full Power Down savings. This signal may instead be used as a GPIO.
LAN_RSTSYNC	O	<b>LAN Reset/Sync:</b> This is the reset/sync signal from the GbE LAN interface to the physical device. The LAN Connect component's Reset and Sync signals are multiplexed onto this pin.  <b>NOTE:</b> The signal is shared between LAN Connect Interface and Gigabit LAN Connect Interface.

## 2.5 Firmware Hub Interface

**Table 9. Firmware Hub Interface Signals**

Name	Type	Description
<b>FWH[3:0] /</b> LAD[3:0]	I/O	Firmware Hub Signals. These signals are multiplexed with the LPC address signals.
<b>FWH4 /</b> LFRAME#	O	Firmware Hub Signals. This signal is multiplexed with the LPC LFRAME# signal.



## 2.6 PCI Interface

Table 10. PCI Interface Signals (Sheet 1 of 3)

Name	Type	Description																								
<b>AD[31:0]</b>	I/O	<b>PCI Address/Data:</b> AD[31:0] is a multiplexed address and data bus. During the first clock of a transaction, AD[31:0] contain a physical address (32 bits). During subsequent clocks, AD[31:0] contain data. The Intel® ICH8 will drive all 0s on AD[31:0] during the address phase of all PCI Special Cycles.																								
<b>C/BE[3:0]#</b>	I/O	<p><b>Bus Command and Byte Enables:</b> The command and byte enable signals are multiplexed on the same PCI pins. During the address phase of a transaction, C/BE[3:0]# define the bus command. During the data phase C/BE[3:0]# define the Byte Enables.</p> <table border="0"> <thead> <tr> <th>C/BE[3:0]#</th> <th>Command Type</th> </tr> </thead> <tbody> <tr> <td>0000b</td> <td>Interrupt Acknowledge</td> </tr> <tr> <td>0001b</td> <td>Special Cycle</td> </tr> <tr> <td>0010b</td> <td>I/O Read</td> </tr> <tr> <td>0011b</td> <td>I/O Write</td> </tr> <tr> <td>0110b</td> <td>Memory Read</td> </tr> <tr> <td>0111b</td> <td>Memory Write</td> </tr> <tr> <td>1010b</td> <td>Configuration Read</td> </tr> <tr> <td>1011b</td> <td>Configuration Write</td> </tr> <tr> <td>1100b</td> <td>Memory Read Multiple</td> </tr> <tr> <td>1110b</td> <td>Memory Read Line</td> </tr> <tr> <td>1111b</td> <td>Memory Write and Invalidate</td> </tr> </tbody> </table> <p>All command encodings not shown are reserved. The ICH8 does not decode reserved values, and therefore will not respond if a PCI master generates a cycle using one of the reserved values.</p>	C/BE[3:0]#	Command Type	0000b	Interrupt Acknowledge	0001b	Special Cycle	0010b	I/O Read	0011b	I/O Write	0110b	Memory Read	0111b	Memory Write	1010b	Configuration Read	1011b	Configuration Write	1100b	Memory Read Multiple	1110b	Memory Read Line	1111b	Memory Write and Invalidate
C/BE[3:0]#	Command Type																									
0000b	Interrupt Acknowledge																									
0001b	Special Cycle																									
0010b	I/O Read																									
0011b	I/O Write																									
0110b	Memory Read																									
0111b	Memory Write																									
1010b	Configuration Read																									
1011b	Configuration Write																									
1100b	Memory Read Multiple																									
1110b	Memory Read Line																									
1111b	Memory Write and Invalidate																									
<b>DEVSEL#</b>	I/O	<b>Device Select:</b> The ICH8 asserts DEVSEL# to claim a PCI transaction. As an output, the ICH8 asserts DEVSEL# when a PCI master peripheral attempts an access to an internal ICH8 address or an address destined DMI (main memory or graphics). As an input, DEVSEL# indicates the response to an ICH8-initiated transaction on the PCI bus. DEVSEL# is tri-stated from the leading edge of PLTRST#. DEVSEL# remains tri-stated by the ICH8 until driven by a target device.																								
<b>FRAME#</b>	I/O	<b>Cycle Frame:</b> The current initiator drives FRAME# to indicate the beginning and duration of a PCI transaction. While the initiator asserts FRAME#, data transfers continue. When the initiator negates FRAME#, the transaction is in the final data phase. FRAME# is an input to the ICH8 when the ICH8 is the target, and FRAME# is an output from the ICH8 when the ICH8 is the initiator. FRAME# remains tri-stated by the ICH8 until driven by an initiator.																								



Table 10. PCI Interface Signals (Sheet 2 of 3)

Name	Type	Description
<b>IRDY#</b>	I/O	<b>Initiator Ready:</b> IRDY# indicates the ICH8's ability, as an initiator, to complete the current data phase of the transaction. It is used in conjunction with TRDY#. A data phase is completed on any clock both IRDY# and TRDY# are sampled asserted. During a write, IRDY# indicates the ICH8 has valid data present on AD[31:0]. During a read, it indicates the ICH8 is prepared to latch data. IRDY# is an input to the ICH8 when the ICH8 is the target and an output from the ICH8 when the ICH8 is an initiator. IRDY# remains tri-stated by the ICH8 until driven by an initiator.
<b>TRDY#</b>	I/O	<b>Target Ready:</b> TRDY# indicates the ICH8's ability as a target to complete the current data phase of the transaction. TRDY# is used in conjunction with IRDY#. A data phase is completed when both TRDY# and IRDY# are sampled asserted. During a read, TRDY# indicates that the ICH8, as a target, has placed valid data on AD[31:0]. During a write, TRDY# indicates the ICH8, as a target is prepared to latch data. TRDY# is an input to the ICH8 when the ICH8 is the initiator and an output from the ICH8 when the ICH8 is a target. TRDY# is tri-stated from the leading edge of PLTRST#. TRDY# remains tri-stated by the ICH8 until driven by a target.
<b>STOP#</b>	I/O	<b>Stop:</b> STOP# indicates that the ICH8, as a target, is requesting the initiator to stop the current transaction. STOP# causes the ICH8, as an initiator, to stop the current transaction. STOP# is an output when the ICH8 is a target and an input when the ICH8 is an initiator.
<b>PAR</b>	I/O	<b>Calculated/Checked Parity:</b> PAR uses "even" parity calculated on 36 bits, AD[31:0] plus C/BE[3:0]#. "Even" parity means that the ICH8 counts the number of one within the 36 bits plus PAR and the sum is always even. The ICH8 always calculates PAR on 36 bits regardless of the valid byte enables. The ICH8 generates PAR for address and data phases and only assures PAR to be valid one PCI clock after the corresponding address or data phase. The ICH8 drives and tri-states PAR identically to the AD[31:0] lines except that the ICH8 delays PAR by exactly one PCI clock. PAR is an output during the address phase (delayed one clock) for all ICH8 initiated transactions. PAR is an output during the data phase (delayed one clock) when the ICH8 is the initiator of a PCI write transaction, and when it is the target of a read transaction. ICH8 checks parity when it is the target of a PCI write transaction. If a parity error is detected, the ICH8 will set the appropriate internal status bits, and has the option to generate an NMI# or SMI#.
<b>PERR#</b>	I/O	<b>Parity Error:</b> An external PCI device drives PERR# when it receives data that has a parity error. The ICH8 drives PERR# when it detects a parity error. The ICH8 can either generate an NMI# or SMI# upon detecting a parity error (either detected internally or reported via the PERR# signal).
REQ0# REQ1#/ GPIO50 REQ2#/ GPIO52 REQ3#/GPIO54	I	<b>PCI Requests:</b> The ICH8 supports up to 4 masters on the PCI bus. REQ[3:1]# pins can instead be used as GPIO.





Table 10. PCI Interface Signals (Sheet 3 of 3)

Name	Type	Description
GNT0# GNT1#/ GPIO51 GNT2#/ GPIO53 GNT3#/GPIO55	O	<p><b>PCI Grants:</b> The ICH8 supports up to 4 masters on the PCI bus. GNT[3:1]# pins can instead be used as GPIO. Pull-up resistors are not required on these signals. If pull-ups are used, they should be tied to the Vcc3_3 power rail.</p> <p><b>NOTE:</b> GNT[3:0]# are sampled as a functional strap. See <a href="#">Section 2.26</a> for details.</p>
PCICLK	I	<p><b>PCI Clock:</b> This is a 33 MHz clock. PCICLK provides timing for all transactions on the PCI Bus.</p> <p><b>NOTE:</b> (Mobile Only) This clock does not stop based on STP_PCI# signal. PCI Clock only stops based on SLP_S3#.</p>
PCRST#	O	<p><b>PCI Reset:</b> This is the Secondary PCI Bus reset signal. It is a logical OR of the primary interface PLTRST# signal and the state of the Secondary Bus Reset bit of the Bridge Control register (D30:F0:3Eh, bit 6).</p>
PLOCK#	I/O	<p><b>PCI Lock:</b> This signal indicates an exclusive bus operation and may require multiple transactions to complete. ICH8 asserts PLOCK# when it performs non-exclusive transactions on the PCI bus. PLOCK# is ignored when PCI masters are granted the bus in desktop configurations.</p> <p><b>NOTE:</b> In mobile configuration, devices on the PCI bus (other than the ICH8) are not permitted to assert the PLOCK# signal.</p>
SERR#	I/OD	<p><b>System Error:</b> SERR# can be pulsed active by any PCI device that detects a system error condition. Upon sampling SERR# active, the ICH8 has the ability to generate an NMI, SMI#, or interrupt.</p>
PME#	I/OD	<p><b>PCI Power Management Event:</b> PCI peripherals drive PME# to wake the system from low-power states S1–S5. PME# assertion can also be enabled to generate an SCI from the S0 state. In some cases the ICH8 may drive PME# active due to an internal wake event. The ICH8 will not drive PME# high, but it will be pulled up to VccSus3_3 by an internal pull-up resistor.</p>

## 2.7 Serial ATA Interface

Table 11. Serial ATA Interface Signals (Sheet 1 of 3)

Name	Type	Description
<b>SATA0TXP</b> <b>SATA0TXN</b>	O	<b>Serial ATA Differential Transmit Pairs:</b> These are outbound high-speed differential signals to Port 0. In compatible mode, SATA Port 0 is the primary master of SATA Controller 1.
<b>SATA0RXP</b> <b>SATA0RXN</b>	I	<b>Serial ATA 0 Differential Receive Pair:</b> These are inbound high-speed differential signals from Port 0. In compatible mode, SATA Port 0 is the primary master of SATA Controller 1.
<b>SATA1TXP</b> <b>SATA1TXN</b>	O	<b>Serial ATA 1 Differential Transmit Pair:</b> These are outbound high-speed differential signals to Port 1. In compatible mode, SATA Port 1 is the secondary master of SATA Controller 1.
<b>SATA1RXP</b> <b>SATA1RXN</b>	I	<b>Serial ATA 1 Differential Receive Pair:</b> These are inbound high-speed differential signals from Port 1. In compatible mode, SATA Port 1 is the secondary master of SATA Controller 1.
<b>SATA2TXP</b> <b>SATA2TXN</b>	O	<b>Serial ATA 2 Differential Transmit Pair:</b> These are outbound high-speed differential signals to Port 2. In compatible mode, SATA Port 2 is the primary slave of SATA Controller 1.  <b>NOTE:</b> This port is not functional in the Desktop ICH8 Base component.
<b>SATA2RXP</b> <b>SATA2RXN</b>	I	<b>Serial ATA 2 Differential Receive Pair:</b> These are inbound high-speed differential signals from Port 2. In compatible mode, SATA Port 2 is the primary slave of SATA Controller 1.  <b>NOTE:</b> This port is not functional in the Desktop ICH8 Base component.
<b>SATA3TXP</b> <b>SATA3TXN</b> (Desktop Only)	O	<b>Serial ATA 3 Differential Transmit Pair:</b> These are outbound high-speed differential signals to Port 3 In compatible mode, SATA Port 3 is the secondary slave of SATA Controller 1.  <b>NOTE:</b> This port is not functional in the Desktop ICH8 Base component.
<b>SATA3RXP</b> <b>SATA3RXN</b> (Desktop Only)	I	<b>Serial ATA 3 Differential Receive Pair:</b> These are inbound high-speed differential signals from Port 3 In compatible mode, SATA Port 3 is the secondary slave of SATA Controller 1.  <b>NOTE:</b> This port is not functional in the Desktop ICH8 Base component.
<b>SATA4TXP</b> <b>SATA4TXN</b> (Desktop Only)	O	<b>Serial ATA 4 Differential Transmit Pair:</b> These are outbound high-speed differential signals to Port 4. In compatible mode, SATA Port 4 is the primary master of SATA Controller 2.



Table 11. Serial ATA Interface Signals (Sheet 2 of 3)

Name	Type	Description
<b>SATA4RXP</b> <b>SATA4RXN</b> (Desktop Only)	I	<b>Serial ATA 4 Differential Receive Pair:</b> These are inbound high-speed differential signals from Port 4. In compatible mode, SATA Port 4 is the primary master of SATA Controller 2
<b>SATA5TXP</b> <b>SATA5TXN</b> (Desktop Only)	O	<b>Serial ATA 5 Differential Transmit Pair:</b> These are outbound high-speed differential signals to Port 5. In compatible mode, SATA Port 5 is the secondary master of SATA Controller 2
<b>SATA5RXP</b> <b>SATA5RXN</b> (Desktop Only)	I	<b>Serial ATA 5 Differential Receive Pair:</b> These are inbound high-speed differential signals from Port 5. In compatible mode, SATA Port 5 is the secondary master of SATA Controller 2
<b>SATARBIAS</b>	O	<b>Serial ATA Resistor Bias:</b> These are analog connection points for an external resistor to ground.
<b>SATARBIAS#</b>	I	<b>Serial ATA Resistor Bias Complement:</b> These are analog connection points for an external resistor to ground.
<b>SATA0GP</b> / GPIO21	I	<b>Serial ATA 0 General Purpose:</b> This is an input pin which can be configured as an interlock switch corresponding to SATA Port 0. When used as an interlock switch status indication, this signal should be drive to '0' to indicate that the switch is closed and to '1' to indicate that the switch is open. If interlock switches are not required, this pin can be configured as GPIO21.
<b>SATA1GP</b> / GPIO19	I	<b>Serial ATA 1 General Purpose:</b> Same function as SATA0GP, except for SATA Port 1. If interlock switches are not required, this pin can be configured as GPIO19.
<b>SATA2GP</b> (ICH8R Only) / GPIO36	I	<b>Serial ATA 2 General Purpose:</b> Same function as SATA0GP, except for SATA Port 2. If interlock switches are not required, this pin can be configured as GPIO36. <b>NOTE:</b> This signal can only be used as GPIO36 in the Desktop ICH8 Base component.
<b>SATA3GP</b> (Desktop Only) / GPIO37	I	<b>Serial ATA 3 General Purpose:</b> Same function as SATA0GP, except for SATA Port 3. If interlock switches are not required, this pin can be configured as GPIO37. <b>NOTE:</b> This signal can only be used as GPIO37 in the Desktop ICH8 Base component.
<b>SATA4GP</b> (Desktop Only)	I	<b>Serial ATA 4 General Purpose:</b> Same function as SATA0GP, except for SATA Port 4.
<b>SATA5GP</b> (Desktop Only)	I	<b>Serial ATA 5 General Purpose:</b> Same function as SATA0GP, except for SATA Port 5.

Table 11. Serial ATA Interface Signals (Sheet 3 of 3)

Name	Type	Description
SATALED#	OC	<b>Serial ATA LED:</b> This is an open-collector output pin driven during SATA command activity. It is to be connected to external circuitry that can provide the current to drive a platform LED. When active, the LED is on. When tri-stated, the LED is off. An external pull-up resistor to Vcc3_3 is required. <b>Note:</b> This is sampled as a functional strap. See Strapping section for details.
SATACLKREQ# /GPIO35	OD (Native) / I/O (GP)	<b>Serial ATA Clock Request:</b> This is an open-drain output pin when configured as SATACLKREQ#. It is to connect to the system clock chip. When active, request for SATA Clock running is asserted. When tri-stated, it tells the clock chip that SATA clock can be stopped. An external pull-up resistor is required.
SCLOCK/ GPIO22	OD (Native)/ I/O (GP)	<b>SGPIO Reference Clock:</b> The SATA controller uses rising edges of this clock to transmit serial data, and the target uses the falling edge of this clock to latch data. If SGPIO interface is not used, this signal can be used as a GPIO.
SLOAD/GPIO38	OD (Native)/ I/O (GP)	<b>SGPIO Load:</b> The controller drives a 1 at the rising edge of SCLOCK to indicate either the start or end of a bit stream. A 4-bit vendor specific pattern will be transmitted right after the signal assertion. If SGPIO interface is not used, this signal can be used as a GPIO.
SDATAOUT0/ GPIO39 SDATAOUT1/ GPIO48	OD (Native)/ I/O (GP)	<b>SGPIO Dataout:</b> Driven by the controller to indicate the drive status in the following sequence: drive 0, 1, 2, n, 0, 1, 2, n, 2... If SGPIO interface is not used, the signals can be used as GPIO.

## 2.8 IDE Interface (Mobile Only)

Table 12. IDE Interface Signals (Mobile Only)

Name	Type	Description
DCS1#	O	<b>IDE Device Chip Selects for 100 Range:</b> For ATA command register block. This output signal is connected to the corresponding signal on the IDE connector.
DCS3#	O	<b>IDE Device Chip Select for 300 Range:</b> For ATA control register block. This output signal is connected to the corresponding signal on the IDE connector.
DA[2:0]	O	<b>IDE Device Address:</b> These output signals are connected to the corresponding signals on the IDE connector. They are used to indicate which byte in either the ATA command block or control block is being addressed.
DD[15:0]	I/O	<b>IDE Device Data:</b> These signals directly drive the corresponding signals on the IDE connector. There is a weak internal pull-down resistor on DD7.
DDREQ	I	<b>IDE Device DMA Request:</b> This input signal is directly driven from the DRQ signal on the IDE connector. It is asserted by the IDE device to request a data transfer, and used in conjunction with the PCI bus master IDE function and are not associated with any AT compatible DMA channel. There is a weak internal pull-down resistor on this signal.



Table 12. IDE Interface Signals (Mobile Only)

Name	Type	Description
DDACK#	O	<b>IDE Device DMA Acknowledge:</b> This signal directly drives the DAK# signal on the IDE connector. DDACK# is asserted by the Intel® ICH8 to indicate to IDE DMA slave devices that a given data transfer cycle (assertion of DIOR# or DIOW#) is a DMA data transfer cycle. This signal is used in conjunction with the PCI bus master IDE function and are not associated with any AT-compatible DMA channel.
<b>DIOR# /</b> (DWSTB / RDMARDY#)	O	<b>Disk I/O Read (PIO and Non-Ultra DMA):</b> This is the command to the IDE device that it may drive data onto the DD lines. Data is latched by the ICH8 on the deassertion edge of DIOR#. The IDE device is selected either by the ATA register file chip selects (DCS1# or DCS3#) and the DA lines, or the IDE DMA acknowledge (DDAK#). <b>Disk Write Strobe (Ultra DMA Writes to Disk):</b> This is the data write strobe for writes to disk. When writing to disk, ICH8 drives valid data on rising and falling edges of DWSTB. <b>Disk DMA Ready (Ultra DMA Reads from Disk):</b> This is the DMA ready for reads from disk. When reading from disk, ICH8 deasserts RDMARDY# to pause burst data transfers.
<b>DIOW# /</b> (DSTOP)	O	<b>Disk I/O Write (PIO and Non-Ultra DMA):</b> This is the command to the IDE device that it may latch data from the DD lines. Data is latched by the IDE device on the deassertion edge of DIOW#. The IDE device is selected either by the ATA register file chip selects (DCS1# or DCS3#) and the DA lines, or the IDE DMA acknowledge (DDAK#). <b>Disk Stop (Ultra DMA):</b> ICH8 asserts this signal to terminate a burst.
<b>IORDY /</b> (DRSTB / WDMARDY#)	I	<b>I/O Channel Ready (PIO):</b> This signal will keep the strobe active (DIOR# on reads, DIOW# on writes) longer than the minimum width. It adds wait-states to PIO transfers. <b>Disk Read Strobe (Ultra DMA Reads from Disk):</b> When reading from disk, ICH8 latches data on rising and falling edges of this signal from the disk. <b>Disk DMA Ready (Ultra DMA Writes to Disk):</b> When writing to disk, this is de-asserted by the disk to pause burst data transfers.

## 2.9 LPC Interface

Table 13. LPC Interface Signals

Name	Type	Description
<b>LAD[3:0] /</b> FWH[3:0]	I/O	<b>LPC Multiplexed Command, Address, Data:</b> For LAD[3:0], internal pull-ups are provided.
<b>LFRAME# /</b> FWH4	O	<b>LPC Frame:</b> LFRAME# indicates the start of an LPC cycle, or an abort.
<b>LDRQ0#</b> <b>LDRQ1# /</b> GPIO23	I	<b>LPC Serial DMA/Master Request Inputs:</b> LDRQ[1:0]# are used to request DMA or bus master access. These signals are typically connected to external Super I/O device. An internal pull-up resistor is provided on these signals. LDRQ1# may optionally be used as GPIO.



## 2.10 Interrupt Interface

Table 14. Interrupt Signals

Name	Type	Description
SERIRQ	I/O	<b>Serial Interrupt Request:</b> This pin implements the serial interrupt protocol.
PIRQ[D:A]#	I/OD	<b>PCI Interrupt Requests:</b> In non-APIC mode the PIRQx# signals can be routed to interrupts 3, 4, 5, 6, 7, 9, 10, 11, 12, 14 or 15 as described in the Interrupt Steering section. Each PIRQx# line has a separate Route Control register. In APIC mode, these signals are connected to the internal I/O APIC in the following fashion: PIRQA# is connected to IRQ16, PIRQB# to IRQ17, PIRQC# to IRQ18, and PIRQD# to IRQ19. This frees the legacy interrupts.
PIRQ[H:E]# / GPIO[5:2]	I/OD	<b>PCI Interrupt Requests:</b> In non-APIC mode the PIRQx# signals can be routed to interrupts 3, 4, 5, 6, 7, 9, 10, 11, 12, 14 or 15 as described in the <i>Interrupt Steering</i> section. Each PIRQx# line has a separate Route Control register. In APIC mode, these signals are connected to the internal I/O APIC in the following fashion: PIRQE# is connected to IRQ20, PIRQF# to IRQ21, PIRQG# to IRQ22, and PIRQH# to IRQ23. This frees the legacy interrupts. If not needed for interrupts, these signals can be used as GPIO.
IDEIRQ (Mobile Only)	I	<b>IDE Interrupt Request:</b> This interrupt input is connected to the IDE drive.



## 2.11 USB Interface

Table 15. USB Interface Signals

Name	Type	Description
USBP0P, USBP0N, USBP1P, USBP1N	I/O	<p><b>Universal Serial Bus Port [1:0] Differential:</b> These differential pairs are used to transmit Data/Address/Command signals for ports 0 and 1. These ports can be routed to UHCI controller #1 or the EHCI controller #1.</p> <p><b>NOTE:</b> No external resistors are required on these signals. The Intel® ICH8 integrates 15 kΩ pull-downs and provides an output driver impedance of 45 Ω which requires no external series resistor</p>
USBP2P, USBP2N, USBP3P, USBP3N	I/O	<p><b>Universal Serial Bus Port [3:2] Differential:</b> These differential pairs are used to transmit data/address/command signals for ports 2 and 3. These ports can be routed to UHCI controller #2 or the EHCI controller #1.</p> <p><b>NOTE:</b> No external resistors are required on these signals. The ICH8 integrates 15 kΩ pull-downs and provides an output driver impedance of 45 Ω which requires no external series resistor</p>
USBP4P, USBP4N, USBP5P, USBP5N	I/O	<p><b>Universal Serial Bus Port [5:4] Differential:</b> These differential pairs are used to transmit Data/Address/Command signals for ports 4 and 5. These ports can be routed to UHCI controller #3 or the EHCI controller #1.</p> <p><b>NOTE:</b> No external resistors are required on these signals. The ICH8 integrates 15 kΩ pull-downs and provides an output driver impedance of 45 Ω which requires no external series resistor</p>
USBP6P, USBP6N, USBP7P, USBP7N	I/O	<p><b>Universal Serial Bus Port [7:6] Differential:</b> These differential pairs are used to transmit Data/Address/Command signals for ports 6 and 7. These ports can be routed to UHCI controller #4 or the EHCI controller #2.</p> <p><b>NOTE:</b> No external resistors are required on these signals. The ICH8 integrates 15 kW pull-downs and provides an output driver impedance of 45 W which requires no external series resistor</p>
USBP8P, USBP8N, USBP9P, USBP9N	I/O	<p><b>Universal Serial Bus Port [9:8] Differential:</b> These differential pairs are used to transmit Data/Address/Command signals for ports 8 and 9. These ports can be routed to UHCI controller #5 or the EHCI controller #2.</p> <p><b>NOTE:</b> No external resistors are required on these signals. The ICH8 integrates 15 kW pull-downs and provides an output driver impedance of 45 W which requires no external series resistor</p>

Table 15. USB Interface Signals

Name	Type	Description
OCO# OC1# / GPIO40 OC2# / GPIO41 OC3# / GPIO42 OC4# / GPIO43 OC5# / GPIO29 OC6# / GPIO30 OC7# / GPIO31 OC[9:8]#	I	<b>Overcurrent Indicators:</b> These signals set corresponding bits in the USB controllers to indicate that an overcurrent condition has occurred. OC[7:1]# may optionally be used as GPIOs.  <b>NOTE:</b> OC[9:0]# are not 5 V tolerant.
USBRBIAS	O	<b>USB Resistor Bias:</b> Analog connection point for an external resistor. Used to set transmit currents and internal load resistors.
USBRBIAS#	I	<b>USB Resistor Bias Complement:</b> Analog connection point for an external resistor. Used to set transmit currents and internal load resistors.

## 2.12 Power Management Interface

Table 16. Power Management Interface Signals (Sheet 1 of 4)

Name	Type	Description
PLTRST#	O	<b>Platform Reset:</b> The Intel® ICH8 asserts PLTRST# to reset devices on the platform (e.g., SIO, FWH, LAN, (G)MCH, TPM, etc.). The ICH8 asserts PLTRST# during power-up and when S/W initiates a hard reset sequence through the Reset Control register (I/O Register CF9h). The ICH8 drives PLTRST# inactive a minimum of 1 ms after both PWROK and VRMPWRGD are driven high. The ICH8 drives PLTRST# active a minimum of 1 ms when initiated through the Reset Control register (I/O Register CF9h).  <b>NOTE:</b> PLTRST# is in the VccSus3_3 well.
THRM#	I	<b>Thermal Alarm:</b> Active low signal generated by external hardware to generate an SMI# or SCI.
THRMTRIP#	I	<b>Thermal Trip:</b> When low, this signal indicates that a thermal trip from the processor occurred, and the ICH8 will immediately transition to a S5 state. The ICH8 will not wait for the processor stop grant cycle since the processor has overheated.
SLP_S3#	O	<b>S3 Sleep Control:</b> SLP_S3# is for power plane control. This signal shuts off power to all non-critical systems when in S3 (Suspend To RAM), S4 (Suspend to Disk), or S5 (Soft Off) states.





Table 16. Power Management Interface Signals (Sheet 2 of 4)

Name	Type	Description
SLP_S4#	O	<p><b>S4 Sleep Control:</b> SLP_S4# is for power plane control. This signal shuts power to all non-critical systems when in the S4 (Suspend to Disk) or S5 (Soft Off) state.</p> <p><b>NOTE:</b> This pin must be used to control the DRAM power in order to use the ICH8's DRAM power-cycling feature. Refer to <a href="#">Chapter 5.13.11.2</a> for details</p> <p><b>NOTE:</b> In a system with Intel AMT support, this signal should be used to control the DRAM power. In M1 state (where the host platform is in S3-S5 states and the manageability sub-system is running) the signal is forced high along with SLP_M# in order to properly maintain power to the DIMM used for manageability sub-system.</p>
SLP_S5#	O	<p><b>S5 Sleep Control:</b> SLP_S5# is for power plane control. This signal is used to shut power off to all non-critical systems when in the S5 (Soft Off) states.</p>
SLP_M#	O	<p><b>Manageability Sleep State Control:</b> This signal is used to control power planes to the Intel AMT sub-system. IF no ME firmware is present, SLP_M# will have the same timings as SLP_S3#.</p>
S4_STATE#/ GPIO26	O	<p><b>S4 State Indication:</b> This signals asserts low when the host platform is in S4 or S5 state. In platforms where the manageability engine is forcing the SLP_S4# high along with SLP_M#, this signal can be used by other devices on the board to know when the host platform is below the S3 state.</p>
PWROK	I	<p><b>Power OK:</b> When asserted, PWROK is an indication to the ICH8 that all power rails have been stable for 99 ms and that PCICLK has been stable for 1 ms. PWROK can be driven asynchronously. When PWROK is negated, the ICH8 asserts PLTRST#.</p> <p><b>NOTE:</b> PWROK must deassert for a minimum of three RTC clock periods in order for the ICH8 to fully reset the power and properly generate the PLTRST# output.</p>
CLPWROK	I	<p><b>Controller Link Power OK:</b> When asserted, this signal indicates that power to the Controller Link subsystem ((G)MCH, ICH8, etc.) is stable and tells the ICH8 to deassert CL_RST# to the (G)MCH.</p> <p><b>NOTES:</b></p> <ol style="list-style-type: none"> <li>CLPWROK must not assert before RSMRST# deasserts</li> <li>CLPWROK must not assert after PWROK asserts</li> </ol>
PWRBTN#	I	<p><b>Power Button:</b> The Power Button will cause SMI# or SCI to indicate a system request to go to a sleep state. If the system is already in a sleep state, this signal will cause a wake event. If PWRBTN# is pressed for more than 4 seconds, this will cause an unconditional transition (power button override) to the S5 state. Override will occur even if the system is in the S1-S4 states. This signal has an internal pull-up resistor and has an internal 16 ms de-bounce on the input.</p>
RI #	I	<p><b>Ring Indicate:</b> This signal is an input from a modem. It can be enabled as a wake event, and this is preserved across power failures.</p>



Table 16. Power Management Interface Signals (Sheet 3 of 4)

Name	Type	Description
<b>SYS_RESET#</b>	I	<b>System Reset:</b> This pin forces an internal reset after being debounced. The ICH8 will reset immediately if the SMBus is idle; otherwise, it will wait up to 25 ms ± 2 ms for the SMBus to idle before forcing a reset on the system.
<b>RSMRST#</b>	I	<b>Resume Well Reset:</b> This signal is used for resetting the resume power plane logic. This signal must be asserted for at least 10 ms after the suspend power wells are valid. When deasserted, this signal is an indication that the suspend power wells are stable.
<b>LAN_RST#</b>	I	LAN Reset: When asserted, the internal LAN controller is in reset. This signal must be asserted until the LAN power wells (VccLAN3_3 and VccLAN1_05) and VccCL3_3 power well are valid. When deasserted, this signal is an indication that the LAN power wells are stable.  <b>NOTES:</b> 1. LAN_RST# must not deassert before RSMRST# deasserts 2. LAN_RST# must not deassert after PWROK asserts. 3. If integrated LAN is not used LAN_RST# can be tied to Vss.
<b>WAKE#</b>	I	<b>PCI Express* Wake Event:</b> Sideband wake signal on PCI Express asserted by components requesting wake up.
<b>MCH_SYNC#</b>	I	<b>MCH SYNC:</b> This input is internally ANDed with the PWROK input. This signal is connect to the ICH_SYNC# output of (G)MCH.
<b>SUS_STAT# / LPCPD#</b>	O	<b>Suspend Status:</b> This signal is asserted by the ICH8 to indicate that the system will be entering a low power state soon. This can be monitored by devices with memory that need to switch from normal refresh to suspend refresh mode. It can also be used by other peripherals as an indication that they should isolate their outputs that may be going to powered-off planes. This signal is called LPCPD# on the LPC interface.
<b>SUSCLK</b>	O	<b>Suspend Clock:</b> This clock is an output of the RTC generator circuit to use by other chips for refresh clock.
<b>VRMPWRGD</b>	I	<b>VRM Power Good:</b> This signal should be connected to be the processor's VRM Power Good signifying the VRM is stable. This signal is internally ANDed with the PWROK input. This signal is in the resume well.
<b>CK_PWRGD</b>	O	<b>Clock Generator Power Good:</b> indicates to the clock generator when the main power well is valid. This signal is asserted high when both SLP_S3# and VRMPWRGD are high.
<b>BMBUSY#</b> (Mobile Only) / GPIO0 (Desktop Only)	I	<b>Bus Master Busy:</b> To support the C3 state. Indication that a bus master device is busy. When this signal is asserted, the BM_STS bit will be set. If this signal goes active in a C3 state, it is treated as a break event.  <b>NOTE:</b> This signal is internally synchronized using the PCICLK and a two-stage synchronizer. It does not need to meet any particular setup or hold time.  <b>NOTE:</b> In desktop configurations, this signal is a GPIO.
<b>CLKRUN#</b> (Mobile Only)/ GPIO32 (Desktop Only)	I/O	<b>PCI Clock Run:</b> This signal is used to support PCI CLKRUN protocol. It connects to peripherals that need to request clock restart or prevention of clock stopping.



Table 16. Power Management Interface Signals (Sheet 4 of 4)

Name	Type	Description
<b>STP_PCI#</b> (Mobile Only) / GPIO15 (Desktop Only)	O	<b>Stop PCI Clock:</b> This signal is an output to the external clock generator for it to turn off the PCI clock. It is used to support PCI CLKRUN# protocol. This pin is also used to communicate the host clock frequency select for ME operation.  If this functionality is not needed, this signal can be configured as a GPIO.
<b>STP_CPU#</b> (Mobile Only) / GPIO25 (Desktop Only)	O	<b>Stop CPU Clock:</b> This signal is an output to the external clock generator for it to turn off the processor clock. It is used to support the C3 state. This pin is also used to communicate the host clock frequency select for ME operation.  If this functionality is not needed, this signal can be configured as a GPIO.
<b>BATLOW#</b> (Mobile Only) / TP0 (Desktop Only)	I	<b>Battery Low:</b> This signal is an input from battery to indicate that there is insufficient power to boot the system. Assertion will prevent wake from S3–S5 state. This signal can also be enabled to cause an SMI# when asserted.
<b>DPRSLPVR</b> (Mobile Only) / GPIO16 (Desktop Only)	O	<b>Deeper Sleep - Voltage Regulator:</b> This signal is used to lower the voltage of VRM during the C4 state. When the signal is high, the voltage regulator outputs the lower “Deeper Sleep” voltage. When low (default), the voltage regulator outputs the higher “Normal” voltage.
<b>DPRSTP#</b> (Mobile Only) / TP1 (Desktop Only)	O	<b>Deeper Stop:</b> This is a copy of the DPRSLPVR and it is active low.

## 2.13 Processor Interface

Table 17. Processor Interface Signals (Sheet 1 of 2)

Name	Type	Description
<b>A20M#</b>	O	<b>Mask A20:</b> A20M# will go active based on either setting the appropriate bit in the Port 92h register, or based on the A20GATE input being active.
<b>CPUSLP#</b> (Desktop Only)	O	<b>CPU Sleep:</b> This signal puts the processor into a state that saves substantial power compared to Stop-Grant state. However, during that time, no snoops occur. The Intel® ICH8 can optionally assert the CPUSLP# signal when going to the S1 state.
<b>FERR#</b>	I	<b>Numeric Coprocessor Error:</b> This signal is tied to the coprocessor error signal on the processor. FERR# is only used if the ICH8 coprocessor error reporting function is enabled in the OIC.CEN register (Chipset Configuration Registers: Offset 31FFh: bit 1). If FERR# is asserted, the ICH8 generates an internal IRQ13 to its interrupt controller unit. It is also used to gate the IGNNE# signal to ensure that IGNNE# is not asserted to the processor unless FERR# is active. FERR# requires an external weak pull-up to ensure a high level when the coprocessor error function is disabled.  <b>NOTE:</b> FERR# can be used in some states for notification by the processor of pending interrupt events. This functionality is independent of the OIC register bit setting.

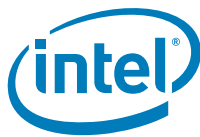


Table 17. Processor Interface Signals (Sheet 2 of 2)

Name	Type	Description
<b>IGNNE#</b>	O	<b>Ignore Numeric Error:</b> This signal is connected to the ignore error pin on the processor. IGNNE# is only used if the ICH8 coprocessor error reporting function is enabled in the OIC.CEN register (Chipset Configuration Registers: Offset 31FFh: bit 1). If FERR# is active, indicating a coprocessor error, a write to the Coprocessor Error register (I/O register F0h) causes the IGNNE# to be asserted. IGNNE# remains asserted until FERR# is negated. If FERR# is not asserted when the Coprocessor Error register is written, the IGNNE# signal is not asserted.
<b>INIT#</b>	O	<b>Initialization:</b> INIT# is asserted by the ICH8 for 16 PCI clocks to reset the processor. ICH8 can be configured to support processor Built In Self Test (BIST).
<b>INIT3_3V#</b> (Desktop Only)	O	<b>Initialization 3.3 V:</b> This is the identical 3.3 V copy of INIT# intended for Firmware Hub.
<b>INTR</b>	O	<b>CPU Interrupt:</b> INTR is asserted by the ICH8 to signal the processor that an interrupt request is pending and needs to be serviced. It is an asynchronous output and normally driven low.
<b>NMI</b>	O	<b>Non-Maskable Interrupt:</b> NMI is used to force a non-Maskable interrupt to the processor. The ICH8 can generate an NMI when either SERR# is asserted or IOCHK# goes active via the SERIRQ# stream. The processor detects an NMI when it detects a rising edge on NMI. NMI is reset by setting the corresponding NMI source enable/disable bit in the NMI Status and Control register (I/O Register 61h).
<b>SMI#</b>	O	<b>System Management Interrupt:</b> SMI# is an active low output synchronous to PCICLK. It is asserted by the ICH8 in response to one of many enabled hardware or software events.
<b>STPCLK#</b>	O	<b>Stop Clock Request:</b> STPCLK# is an active low output synchronous to PCICLK. It is asserted by the ICH8 in response to one of many hardware or software events. When the processor samples STPCLK# asserted, it responds by stopping its internal clock.
<b>RCIN#</b>	I	<b>Keyboard Controller Reset CPU:</b> The keyboard controller can generate INIT# to the processor. This saves the external OR gate with the ICH8's other sources of INIT#. When the ICH8 detects the assertion of this signal, INIT# is generated for 16 PCI clocks.  <b>NOTE:</b> The ICH8 will ignore RCIN# assertion during transitions to the S1, S3, S4, and S5 states.
<b>A20GATE</b>	I	<b>A20 Gate:</b> A20GATE is from the keyboard controller. The signal acts as an alternative method to force the A20M# signal active. It saves the external OR gate needed with various other chipsets.
<b>CPUPWRGD /</b> GPIO49	O	<b>CPU Power Good:</b> This signal should be connected to the processor's PWRGOOD input to indicate when the processor power is valid. This is an output signal that represents a logical AND of the ICH8's PWROK and VRMPWRGD signals. This signal may optionally be configured as a GPIO.
<b>DPSLP#</b> (Mobile Only) / TP2 (Desktop Only)	O	<b>Deeper Sleep:</b> DPSLP# is asserted by the ICH8 to the processor. When the signal is low, the processor enters the deep sleep state by gating off the processor Core Clock inside the processor. When the signal is high (default), the processor is not in the deep sleep state.



## 2.14 SMBus Interface

Table 18. SM Bus Interface Signals

Name	Type	Description
<b>SMBDATA</b>	I/OD	<b>SMBus Data:</b> External pull-up resistor is required.
<b>SMBCLK</b>	I/OD	<b>SMBus Clock:</b> External pull-up resistor is required.
<b>SMBALERT# / GPIO11</b>	I	<b>SMBus Alert:</b> This signal is used to wake the system or generate SMI#. If not used for SMBALERT#, it can be used as a GPIO.

## 2.15 System Management Interface

Table 19. System Management Interface Signals (Sheet 1 of 2)

Name	Type	Description
<b>INTRUDER#</b>	I	<b>Intruder Detect:</b> This signal can be set to disable system if box detected open. This signal's status is readable, so it can be used like a GPIO if the Intruder Detection is not needed.
<b>SMLINK[1:0]</b>	I/OD	<b>System Management Link:</b> SMBus link to optional external system management ASIC or LAN controller. External pull-ups are required. Note that SMLINK0 corresponds to an SMBus Clock signal, and SMLINK1 corresponds to an SMBus Data signal.
<b>LINKALERT# / CL_RST1#</b>	I/OD	<b>SMLink Alert:</b> Output of the integrated LAN and input to either the integrated ASF or an external management controller in order for the LAN's SMLINK slave to be serviced. When used as LINKALERT#, an external pull-up resistor is required.
<b>CLGPIO0 (MEM_LED) / GPIO24</b>	I/O	<b>Controller Link General Purpose I/O 0:</b> Provides DRAM-powered LED control. Allows for the blinking of an LED circuit to indicate memory activity. This signal can instead be used as GPIO.
<b>SusPwrAck / ALERT# (Mobile Only) / GPIO10</b>	I/O	<b>SusPwrAck/ALERT# (Mobile Only) / GPIO10:</b> The primary use of this pin is for SusPwrAck communication from the Management Engine (ME) to the platform Embedded Controller (EC). ALERT# functionality is provided for backup to facilitate SMBus ME-to-EC and EC-to-ME communication and is not used in the current implementation.  SusPwrAck signal is an output signal used by the ME in conjunction with SLP_M# to indicate to the EC that it acknowledges any Suspend well power down decision by the EC. When the ME asserts this signal high and SLP_M# is low, this indicates to the EC it is safe to power off the Suspend well. Likewise, when the ME de-asserts this signal low and the Suspend well is powered, this indicates to the EC that the ME requires the Suspend well to remain powered. (Active High, Level).  This signal can instead be used as a GPIO. This signal is used as GPIO10 in desktop systems.

Table 19. System Management Interface Signals (Sheet 2 of 2)

Name	Type	Description
<b>AC_PRESENT</b> (Mobile Only)/ GPIO14	I/O	<p><b>AC_PRESENT (Mobile Only) / GPIO14:</b> AC_Present is an anput signal from the platform Embedded Controller (EC) to the Management Engine (ME). The AC_Present signal is used by the EC to indicate to the ME the current power source of the system. When the signal is high, this indicates to the ME that the system is connected to an external AC sources. When the signal is low, this indicates to the ME that the system is connected to a DC (battery) source. The ME uses this information in conjunction with the current system power state to determine what ME power state to run in (MO, M1, or MOFF). (Active High, Level).</p> <p>This signal can instead be used as a GPIO. This signal is used as GPIO14 in desktop systems.</p>
<b>WOL_EN</b> / GPIO9	O	<p><b>Wake On LAN Power Enable:</b> In an Intel® AMT or integrated ASF enabled system, this output signal is driven high by the ICH8 to control the LAN subsystem power (VccLAN3_3, VccCL3_3, LAN PHY Power, and SPI device) to support Wake on LAN (WOL) when the Intel® Manageability Engine is powered off. This functionality is configured and controlled by the Manageability Engine prior to entering the powered off state.</p> <p><b>NOTES:</b></p> <ol style="list-style-type: none"> <li>1. This signal should be OR'd with the SLP_M# signal on the motherboard to determine when to power the LAN subsystem.</li> <li>2. To support WOL out of a G3 state, the WOL_EN pin needs to be pulled high by an external resistor until the Manageability Engine is initialized.</li> </ol> <p>If Intel AMT or integrated ASF are disabled on a board that is configured for WOL_EN support, BIOS must use GPIO9 to control power to the LAN subsystem when entering S3–S5.</p> <p>In platforms that do not support Intel AMT or integrated ASF, this signal is used as GPIO9.</p>

## 2.16 Real Time Clock Interface

Table 20. Real Time Clock Interface

Name	Type	Description
<b>RTCX1</b>	Special	<b>Crystal Input 1:</b> This signal is connected to the 32.768 kHz crystal. If no external crystal is used, then RTCX1 can be driven with the desired clock rate.
<b>RTCX2</b>	Special	<b>Crystal Input 2:</b> This signal is connected to the 32.768 kHz crystal. If no external crystal is used, then RTCX2 should be left floating.



## 2.17 Other Clocks

Table 21. Other Clocks

Name	Type	Description
CLK14	I	<b>Oscillator Clock:</b> This clock is used for 8254 timers. It runs at 14.31818 MHz. This clock is permitted to stop during S3 (or lower) states.
CLK48	I	<b>48 MHz Clock:</b> This clock is used to run the USB controller. It runs at 48.000 MHz. This clock is permitted to stop during S3 (or lower) states.
SATA_CLKP SATA_CLKN	I	<b>100 MHz Differential Clock:</b> These signals are used to run the SATA controller at 100 MHz. This clock is permitted to stop during S3/S4/S5 states.
DMI_CLKP, DMI_CLKN	I	<b>100 MHz Differential Clock:</b> These signals are used to run the Direct Media Interface. Runs at 100 MHz.

## 2.18 Miscellaneous Signals

Table 22. Miscellaneous Signals (Sheet 1 of 2)

Name	Type	Description
INTVRMEN	I	<b>Internal Voltage Regulator Enable:</b> This signal enables the internal VccSus1_05, VccSus1_5 and VccCL1_5 regulators. This signal must be pulled-up to VccRTC.
LAN100_SLP	I	<b>Internal Voltage Regulator Enable:</b> This signal enables the internal voltage regulators powering VccLAN1_05 and VccCL1_05. This signal must be pulled-up to VccRTC.
SPKR	O	<b>Speaker:</b> The SPKR signal is the output of counter 2 and is internally "ANDed" with Port 61h bit 1 to provide Speaker Data Enable. This signal drives an external speaker driver device, which in turn drives the system speaker. Upon PLTRST#, its output state is 0.  <b>NOTE:</b> SPKR is sampled at the rising edge of PWROK as a functional strap. See <a href="#">Section 2.26.1</a> for more details. There is a weak integrated pull-down resistor on SPKR pin.
RTCST#	I	<b>RTC Reset:</b> When asserted, this signal resets register bits in the RTC well.  <b>NOTES:</b> 1. Unless CMOS is being cleared (only to be done in the G3 power state), the RTCST# input must always be high when all other RTC power planes are on. 2. In the case where the RTC battery is dead or missing on the platform, the RTCST# pin must rise before the RSMRST# pin.
TPO (Desktop Only) / BATLOW# (Mobile Only)	I	<b>Test Point 0:</b> This signal must have an external pull-up to VccSus3_3.

Table 22. Miscellaneous Signals (Sheet 2 of 2)

Name	Type	Description
<b>TP1</b> (Desktop Only) / DPRSTP# (Mobile Only)	O	<b>Test Point 1:</b> Route signal to a test point.
<b>TP2</b> (Desktop Only) / DPSLP# (Mobile Only)	O	<b>Test Point 2:</b> Route signal to a test point.
<b>TP3</b>	I/O	<b>Test Point 3:</b> Route signal to a test point.
<b>TP4</b> (Desktop Only) / CL_DATA1 (Mobile Only)	I/O	<b>Test Point 4:</b> Route signal to a test point.
<b>TP5</b> (Desktop Only) / CL_CLK1 (Mobile Only)	I/O	<b>Test Point 5:</b> Route signal to a test point.
<b>TP6</b> (Desktop Only) / CL_VREF1 (Mobile Only)	I/O	<b>Test Point 6:</b> Route signal to a test point.
TP7 (Mobile Only)	I/O	<b>Test Point 7:</b> Route signal to a test point.
TP8 (Mobile Only)	I/O	<b>Test Point 8:</b> Route signal to a test point.

## 2.19 Intel® High Definition Audio Link

Table 23. Intel® High Definition Audio Link Signals (Sheet 1 of 2)

Name	Type	Description
<b>HDA_RST#</b>	O	<b>Intel® High Definition Audio Reset:</b> This signal is a master hardware reset to external codec(s).
<b>HDA_SYNC</b>	O	<b>Intel High Definition Audio Sync:</b> This signal is a 48 kHz fixed rate sample sync to the codec(s). Also used to encode the stream number.  <b>NOTE:</b> HDA_SYNC is sampled at the rising edge of PWROK as a functional strap. See <a href="#">Section 2.26.1</a> for more details. There is a weak integrated pull-down resistor on the HDA_SYNC pin.
<b>HDA_BIT_CLK</b>	O	<b>Intel High Definition Audio Bit Clock Output:</b> 24.000 MHz serial data clock generated by the Intel High Definition Audio controller (the Intel® ICH8). This signal has a weak internal pull-down resistor.





Table 23. Intel® High Definition Audio Link Signals (Sheet 2 of 2)

Name	Type	Description
HDA_SDOUT	O	<b>Intel High Definition Audio Serial Data Out:</b> This signal is the serial TDM data output to the codec(s). This serial output is double-pumped for a bit rate of 48 Mb/s for Intel High Definition Audio. <b>NOTE:</b> HDA_SDOUT is sampled at the rising edge of PWROK as a functional strap. See <a href="#">Section 2.26.1</a> for more details. There is a weak integrated pull-down resistor on the HDA_SDOUT pin.
HDA_SDIN[3:0]	I	<b>Intel High Definition Audio Serial Data In [3:0]:</b> These signals are serial TDM data inputs from the codecs. The serial input is single-pumped for a bit rate of 24 Mb/s for Intel® High Definition Audio. These signals have integrated pull-down resistors, which are always enabled.
HDA_DOCK_EN# (Mobile Only) / GPIO33	I/O	<b>High Definition Audio Dock Enable:</b> This signal controls the external Intel HD Audio docking isolation logic. This is an active low signal. When deasserted the external docking switch is in isolate mode. When asserted the external docking switch electrically connects the Intel HD Audio dock signals to the corresponding Intel® ICH8 signals. This signal is shared with GPIO33. This signal defaults to GPIO33 mode after PLTRST# reset and will be in the high state after PLTRST# reset. BIOS is responsible for configuring GPIO33 to HDA_DOCK_EN# mode.
HDA_DOCK_RST# (Mobile Only) / GPIO34	I/O	<b>High Definition Audio Dock Reset:</b> This signal is a dedicated HDA_RST# signal for the codec(s) in the docking station. Aside from operating independently from the normal HDA_RST# signal, it otherwise works similarly to the HDA_RST# signal. This signal is shared with GPIO34. This signal defaults to GPIO34 mode after PLTRST# reset and will be in the low state after PLTRST# reset. BIOS is responsible for configuring GPIO34 to HDA_DOCK_RST# mode.

**NOTES:**

1. Some signals have integrated pull-ups or pull-downs. Consult table in [Section 3.1](#) for details.

## 2.20 Serial Peripheral Interface (SPI)

Table 24. Serial Peripheral Interface (SPI) Signals

Name	Type	Description
SPI_CS0#	O	<b>SPI Chip Select 0:</b> Used as the SPI bus request signals.
SPI_CS1#	I/O	<b>SPI Chip Select 1:</b> Used as the SPI bus request signals. This signal is also used as Boot BIOS destination selection strap with GNT0#.
SPI_MISO	I	<b>SPI Master IN Slave OUT:</b> Data input pin for ICH8.
SPI_MOSI	O	<b>SPI Master OUT Slave IN:</b> Data output pin for ICH8.
SPI_CLK	O	<b>SPI Clock:</b> SPI clock signal, during idle the bus owner will drive the clock signal low. 17.86 MHz and 31.25 MHz.



## 2.21 Intel® Quick Resume Technology (Intel® ICH8DH Only)

Table 25. Intel® Quick Resume Technology Signals

Name	Type	Description
<b>QRT_STATE[1:0]</b> / GPIO[28:27]	I/O	<b>Intel Quick Resume Technology State:</b> Intel Quick Resume Technology status signals that may optionally be used to drive front chassis indicators. See <a href="#">Section 5.26.3</a> for details. When Intel Quick Resume Technology is enabled, the signals will function as QRT_STATE[1:0] only. Otherwise, the signals are used as GPIOs.

## 2.22 Controller Link

Table 26. Controller Link Signals

Name	Type	Description
CL_CLK0	I/O	<b>Controller Link Clock 0:</b> This signal is a bi-directional clock that connects to the (G)MCH.
CL_DATA0	I/O	<b>Controller Link Data 0:</b> This signal is a bi-directional data signal that connects to the (G)MCH.
CL_VREF0	I	<b>Controller Link Reference Voltage 0:</b> This signal is an external reference voltage for Controller Link 0.
CL_RST0#	O	North Controller Link reset that connects to the (G)MCH.
CL_RST1# / LINKALERT#	OD/O	<b>Controller Link Reset:</b> South Controller link reset that connects to a device supporting Intel Active Management Technology. When used as CL_RST1#, no external pullup or pulldown should be used.
<b>CL_CLK1</b> (Mobile Only)/ TP5 (Desktop Only)	I/O	<b>Controller Link Clock 1:</b> This signal is a bi-directional clock that connects to a device supporting Intel® Active Management Technology
<b>CL_DATA1</b> (Mobile Only) TP4 (Desktop Only)	I/O	<b>Controller Link Data 1:</b> This is a bi-directional data signal that connects to a device supporting Intel® Active Management Technology.
<b>CL_VREF1</b> (Mobile Only) TP6 (Desktop Only)	I	<b>Controller Link Reference Voltage:</b> This signal is an external reference voltage for Controller Link 1.



## 2.23 Intel® Quiet System Technology (Desktop Only)

Table 27. Intel® Quiet System Technology Signals

Name	Type	Description
PWM[2:0]	OD	<b>Fan Pulse Width Modulation Outputs:</b> This is a Pulse Width Modulated duty cycle output signal that is used Intel Quiet System Technology. When controlling a 3-wire fan, this signal controls a power transistor that, in turn, controls power to the fan. When controlling a 4-wire fan, this signal is connected to the “Control” signal on the fan. The polarity of this signal is programmable. The output default is low. These signals are 5 V tolerant.
TACH0/GPIO17 TACH1/GPIO1 TACH2/GPIO6 TACH3/GPIO7	I	<b>Fan Tachometer Inputs:</b> These are Tachometer pulse input signals that are used to measure fan speed. The signals are connected to the “Sense” signal on the fan. Can instead be used as a GPIO signal.
SST	I/O	<b>Simple Serial Transport:</b> Single-wire, serial bus. Connect to SST compliant devices such as SST thermal sensors or voltage sensors.
PECI	I/O	<b>Platform Environmental Control Interface:</b> Single-wire, serial bus. This signal connects to the corresponding pin of the processor for accessing processor digital thermometer.

## 2.24 General Purpose I/O Signals

Table 28. General Purpose I/O Signals (Sheet 1 of 3)

Name	Type	Tolerance	Power Well	Default	Description
GPIO55	I/O	3.3 V	Core	Native	Multiplexed with GNT3#
GPIO54	I/O	5.5 V	Core	Native	Multiplexed with REQ3# (Note 5)
GPIO53	I/O	3.3 V	Core	Native	Multiplexed with GNT2#
GPIO52	I/O	5.5 V	Core	Native	Multiplexed with REQ2# (Note 5)
GPIO51	I/O	3.3 V	Core	Native	Multiplexed with GNT1#
GPIO50	I/O	5.5 V	Core	Native	Multiplexed with REQ1# (Note 5)
GPIO49	I/O	V_CPU_IO	V_CPU_IO	Native	Multiplexed with CPUPWRGD (Note 4)
GPIO48	I/O	3.3 V	Core	GPI	Multiplexed with SDATAOUT1
GPIO[47:44]	N/A	N/A	N/A	N/A	Not implemented.
GPIO[43:40]	I/O	3.3 V	Resume	Native	Multiplexed with OC[4:1]# (Note 5)
GPIO39	I/O	3.3V	Core	GPI	Multiplexed with SDATAOUT0
GPIO38	I/O	3.3 V	Core	GPI	Multiplexed with SLOAD



Table 28. General Purpose I/O Signals (Sheet 2 of 3)

Name	Type	Tolerance	Power Well	Default	Description
GPIO37	I/O	3.3 V	Core	GPI	Mobile: Unmultiplexed. Desktop: Multiplexed with SATA3GP.
GPIO36	I/O	3.3 V	Core	GPI	Multiplexed with SATA2GP.
GPIO35	I/O	3.3 V	Core	GPO	Multiplexed with SATACLKREQ#.
GPIO34	I/O	3.3 V	Core	GPO	Mobile: Multiplexed with HDA_DOCK_RST#. Desktop: Unmultiplexed.
GPIO33	I/O	3.3 V	Core	GPO	Mobile: Multiplexed with HDA_DOCK_EN#. Desktop: Unmultiplexed.
GPIO32 (Desktop Only)	I/O	3.3 V	Core	GPO	Mobile: this GPIO is not implemented and is used instead as CLKRUN#. Desktop: Unmultiplexed.
GPIO31	I/O	3.3 V	Resume	Native	Multiplexed with OC7# (Note 5)
GPIO30	I/O	3.3 V	Resume	Native	Multiplexed with OC6# (Note 5)
GPIO29	I/O	3.3 V	Resume	Native	Multiplexed with OC5# (Note 5)
GPIO28	I/O	3.3 V	Resume	GPO	Digital Home: Multiplexed with QRT_STATE1 ICH8 Base: Unmultiplexed.
GPIO27	I/O	3.3 V	Resume	GPO	Digital Home: Multiplexed with QRT_STATE0 ICH8 Base: Unmultiplexed.
GPIO26	I/O	3.3 V	Resume	Native	Multiplexed with S4_STATE#
GPIO25 (Desktop Only)	I/O	3.3 V	Resume	Native	Mobile: this GPIO is not implemented and is used instead as STP_CPU# Desktop: Default as STP_CPU# (Note 3)
GPIO24	I/O	3.3 V	Resume	GPO	Mobile: Multiplexed with MEM_LED Desktop: Multiplexed with CLGPIO0. Not cleared by CF9h reset event.
GPIO23	I/O	3.3 V	Core	Native	Multiplexed with LDRQ1# (Note 5)
GPIO22	I/O	3.3 V	Core	GPI	Multiplexed with SCLOCK
GPIO21	I/O	3.3 V	Core	GPI	Multiplexed with SATA0GP.
GPIO20	I/O	3.3 V	Core	GPO	Unmultiplexed
GPIO19	I/O	3.3 V	Core	GPI	Multiplexed with SATA1GP
GPIO18	I/O	3.3 V	Core	GPO	Unmultiplexed
GPIO17	I/O	3.3 V	Core	GPI	Multiplexed with TACH0



Table 28. General Purpose I/O Signals (Sheet 3 of 3)

Name	Type	Tolerance	Power Well	Default	Description
GPIO16	I/O	3.3 V	Core	Native (Mobile) / GPO (Desktop)	Mobile: Natively used as DPRSLPVR. Desktop: Unmultiplexed.
GPIO15 (Desktop Only)	I/O	3.3 V	Resume	Native	Mobile: GPIO is not implemented and is used instead as STP_PCI#. Desktop: default as STP_PCI# (Note 3)
GPIO14	I/O	3.3 V	Resume	GPI	Mobile: Multiplexed with AC_PRESENT Desktop: Unmultiplexed
GPIO13	I/O	3.3V	Resume	Native (Mobile) / GPI (Desktop)	Mobile: Natively used as ENERGY_DETECT Desktop: Unmultiplexed
GPIO12	I/O	3.3 V	Resume	Native (Mobile) / GPI (Desktop)	Mobile: Natively used as GLAN_DOCK# Desktop: Unmultiplexed.
GPIO11	I/O	3.3 V	Resume	Native	Multiplexed with SMBALERT# (Note 5)
GPIO10	I/O	3.3 V	Resume	GPI	Mobile: Multiplexed with SusPwrAck/ALERT# Desktop: Unmultiplexed
GPIO9	I/O	3.3 V	Resume	GPI	Refer to <a href="#">Table 19</a> for signal description.
GPIO8	I/O	3.3 V	Resume	GPI	Unmultiplexed
GPIO[7:6]	I/O	3.3 V	Core	GPI	Mobile: Unmultiplexed Desktop: Multiplexed with TACH[3:2]
GPIO[5:2]	I/OD	5 V	Core	GPI	Multiplexed with PIRQ[H:E]#
GPIO1	I/O	3.3 V	Core	GPI	Multiplexed with TACH1
GPIO0	I/O	3.3 V	Core	GPI	Mobile: Multiplexed with BM_BUSY# Desktop: Unmultiplexed

**NOTES:**

1. GPI[15:0] can be configured to cause a SMI# or SCI. Note that a GPI can be routed to either an SMI# or an SCI, but not both.
2. Some GPIOs exist in the VccSus3\_3 power plane. Care must be taken to make sure GPIO signals are not driven high into powered-down planes. Some ICH8 GPIOs may be connected to pins on devices that exist in the core well. If these GPIOs are outputs, there is a danger that a loss of core power (PWROK low) or a Power Button Override event will result in the Intel ICH8 driving a pin to a logic 1 to another device that is powered down.
3. The functionality that is multiplexed with the GPIO may not be used in desktop configuration.
4. This GPIO is not capable of actively driving high. This GPIO is tristated as an output and an external pull-up is needed to pull the signal high).



- When the multiplexed GPIO is used as GPIO functionality, care should be taken to ensure the signal is stable in its inactive state of the native functionality, immediately after reset until it is initialized to GPIO functionality.

## 2.25 Power and Ground

Table 29. Power and Ground Signals (Sheet 1 of 2)

Name	Description
Vcc3_3	3.3 V supply for core well I/O buffers. This power may be shut off in S3, S4, S5 or G3 states.
Vcc1_05	1.05 V supply for core well logic. This power may be shut off in S3, S4, S5 or G3 states.
Vcc1_5_A	1.5 V supply for Logic and I/O. This power may be shut off in S3, S4, S5 or G3 states.
Vcc1_5_B	1.5 V supply for Logic and I/O. This power may be shut off in S3, S4, S5 or G3 states.
Vcc_DMI	Power supply for DMI. 1.25V or 1.5V depending on (G)MCH's DMI voltage.
V5REF	Reference for 5 V tolerance on core well inputs. This power may be shut off in S3, S4, S5 or G3 states.
VccSus3_3	3.3 V supply for resume well I/O buffers. This power is not expected to be shut off unless the system is unplugged in desktop configurations or the main battery is removed or completely drained and AC power is not available in mobile configurations.
VccSus1_5	1.5V supply for the resume well I/O. This power is not expected to be shut off unless the system is unplugged in desktop configurations. This voltage is generated internally (see <a href="#">Section 2.26.1</a> for strapping option). and these pins can be left as NC unless decoupling is required.
VccSus1_05	1.05 V supply for resume well logic. This power is not expected to be shut off unless the system is unplugged in desktop configurations or the main battery is removed or completely drained and AC power is not available in mobile configurations. This voltage is generated internally (see <a href="#">Section 2.26.1</a> for strapping option). and these pins can be left as NC unless decoupling is required.
V5REF_Sus	Reference for 5 V tolerance on resume well inputs. This power is not expected to be shut off unless the system is unplugged in desktop configurations or the main battery is removed or completely drained and AC power is not available in mobile configurations.
VccGLAN1_5	1.5V supply for integrated Gigabit LAN I/O buffers. This power can be turned off if the integrated Gigabit LAN is not used. If the integrated Gigabit LAN is used, the power is off in S3, S4, S5.
VccGLAN3_3	3.3V supply for integrated Gigabit LAN logic and I/O. This power can be turned off if the integrated Gigabit LAN is not used. If the integrated Gigabit LAN is used, the power is off in S3, S4, S5.
VccCL1_05	1.05V supply for Controller Link. This voltage may be generated internally (see <a href="#">Section 2.26.1</a> for strapping option). This pin must be connected to an external 1.05 V power supply when the integrated VRM is disabled. This pin can be left as NC if the internal VRM is used unless decoupling is required.



Table 29. Power and Ground Signals (Sheet 2 of 2)

Name	Description
VccCL1_5	1.5V supply for Controller Link. This plane must be on in S0 and other times Controller Link is used. This voltage is generated internally (see <a href="#">Section 2.26.1</a> for strapping option). and these pins can be left as NC unless decoupling is required.
VccCL3_3	3.3V supply for Controller Link. This is a separate power plane that may or may not be powered in S3–S5 states. This plane must be on in S0 and other times Controller Link is used. <b>NOTE:</b> VccCL3_3 must always be powered when VccLAN3_3 is powered.
VccLAN3_3	3.3 V supply for LAN Connect interface buffers. This is a separate power plane that may or may not be powered in S3–S5 states. <b>NOTE:</b> VccLAN3_3 must always be powered when VccCL3_3 or Vcc3_3 is powered.
VccLAN1_05	1.05 V supply for LAN controller logic. This is a separate power plane that may or may not be powered in S3–S5 states. This voltage is generated internally (see <a href="#">Section 2.26.1</a> for strapping option). and these pins can be left as NC unless decoupling is required..
VccSusHDA	Suspend supply for Intel High Definition Audio. This pin can be either 1.5 or 3.3 V. This power is not expected to be shut off unless the system is unplugged in desktop configurations or the main battery is removed or completely drained and AC power is not available in mobile configurations.
VccHDA	Core supply for Intel High Definition Audio. This pin can be either 1.5 or 3.3 V. This power may be shut off in S3, S4, S5 or G3 states.
VccRTC	3.3 V (can drop to 2.0 V min. in G3 state) supply for the RTC well. This power is not expected to be shut off unless the RTC battery is removed or completely drained. Note: Implementations should not attempt to clear CMOS by using a jumper to pull VccRTC low. Clearing CMOS in an Intel® ICH8-based platform can be done by using a jumper on RTCRST# or GPI.
VccUSBPLL	1.5 V supply for core well logic. This signal is used for the USB PLL. This power may be shut off in S3, S4, S5 or G3 states. Must be powered even if USB not used.
VccDMIPLL	1.5 V supply for core well logic. This signal is used for the DMI PLL. This power may be shut off in S3, S4, S5 or G3 states.
VccSATAPLL	1.5 V supply for core well logic. This signal is used for the SATA PLL. This power may be shut off in S3, S4, S5 or G3 states. Must be powered even if SATA is not used.
VccGLANPLL	1.5V supply for core will logic. This signal is used for the integrated Gigabit LAN PLL. This power is shut off in S3, S4, S5 and G3 states.
V_CPU_IO	Powered by the same supply as the processor I/O voltage. This supply is used to drive the processor interface signals listed in <a href="#">Table 17</a> .
Vss	Grounds.
VSS_NTSC (Mobile Only)	Not critical to function; balls are for improved package Reliability. These signals are connected to GND on the chipset package, and can be connected to GND or left as NC on the platform (can be left as test points). <b>NOTE:</b> There is no functional impact if these signals are grounded.



## 2.26 Pin Straps

### 2.26.1 Functional Straps

The following signals are used for static configuration. They are sampled at the rising edge of PWROK to select configurations (except as noted), and then revert later to their normal usage. To invoke the associated mode, the signal should be driven at least four PCI clocks prior to the time it is sampled.

Intel® ICH8 has implemented a new feature called Soft Straps. Soft Straps are used to configure specific functions within the ICH8 and (G)MCH very early in the boot process before BIOS or software intervention. When Descriptor Mode is enabled, the ICH8 will read Soft Strap data out of the SPI device prior to the de-assertion of reset to both the Manageability Engine and the Host system. Refer to [Section 5.23.1.1](#) for information on Descriptor Mode and [Section 20.2.5](#) for more information on Soft Straps and their settings

**Table 30. Functional Strap Definitions (Sheet 1 of 2)**

Signal	Usage	When Sampled	Comment
HDA_SDOOUT	XOR Chain Entrance / PCI Express* Port Config 1, bit 1 (Port 1–4)	Rising Edge of PWROK	Allows entrance to XOR Chain testing when TP3 pulled low at rising edge of PWROK. When TP3 not pulled low at rising edge of PWROK, sets bit 1 of RPC.PC (Chipset Configuration Registers: Offset 224h). This signal has a weak internal pull-down.
HDA_SYNC	PCI Express Port Config 1, bit 0 (Port 1–4)	Rising Edge of PWROK	This signal has a weak internal pull-down. Sets bit 0 of RPC.PC (Chipset Configuration Registers: Offset 224h)
GNT2#	PCI Express Port Config 2, bit 0 (Port 5–6)	Rising Edge of PWROK	This signal has a weak internal pull-up. Sets bit 2 of RPC.PC2 (Chipset Configuration Registers: Offset 0224h) when sampled low.
GPIO20	Reserved	Rising Edge of PWROK	This signal has a weak internal pull-down. <b>NOTE:</b> This signal should not be pulled high
GNT1#/GPIO51	ESI Strap (Server Only)	Rising edge of PWROK	Tying this strap low configures DMI for ESI-compatible operation. This signal has a weak internal pull-up. <b>NOTE:</b> ESI compatible mode is for server platforms only. This signal should not be pulled low for desktop and mobile.
GNT3#	Top-Block Swap Override	Rising Edge of PWROK	The signal has a weak internal pull-up. If the signal is sampled low, this indicates that the system is strapped to the “top-block swap” mode (Intel® ICH8 inverts A16 for all cycles targeting BIOS space). The status of this strap is readable via the Top Swap bit (Chipset Configuration Registers: Offset 3414h: bit 0). Note that software will not be able to clear the Top-Swap bit until the system is rebooted without GNT3# being pulled down.





Table 30. Functional Strap Definitions (Sheet 2 of 2)

Signal	Usage	When Sampled	Comment
GNT0#, SPI_CS1#	Boot BIOS Destination Selection	Rising Edge of PWROK (Note 1)	This field determines the destination of accesses to the BIOS memory range. Signals have weak internal pull-ups. Also controllable via Boot BIOS Destination bit (Chipset Configuration Registers: Offset 3410h: bit 11:10). (GNT0# is MSB) 01 = SPI 10 = PCI 11 = LPC  <b>NOTE:</b> Booting to PCI is intended for debug/testing only. Boot BIOS Destination Select to LPC/PCI by functional strap or via Boot BIOS Destination Bit will not affect SPI accesses initiated by ME or Integrated GbE LAN.
INTVRMEN	Integrated VccSus1_05, VccSus1_5, and VccCL1_5 VRM Enable	Always	Enables integrated VccSus1_05, VccSus1_5 and VccCL1_5 VRMs. Pin must be pulled-up to VccRTC.
LAN100_SLP	Integrated VccLAN1_05 and VccCL1_05 VRM Enable	Always	Enables integrated VccLAN1_05 and VccCL1_05 VRMs. Pin must be pulled-up to VccRTC.
SATALED#	PCI Express Lane Reversal (Lanes 1–4)	Rising Edge of PWROK	Signal has weak internal pull-up. Sets bit 27 of MPC.LR (Device 28: Function 0: Offset D8)
SPKR	No Reboot	Rising Edge of PWROK	The signal has a weak internal pull-down. If the signal is sampled high, this indicates that the system is strapped to the “No Reboot” mode (ICH8 will disable the TCO Timer system reboot feature). The status of this strap is readable via the NO REBOOT bit (Chipset Configuration Registers: Offset 3410h: bit 5).
TP3	XOR Chain Entrance	Rising Edge of PWROK	See <a href="#">Chapter 29</a> for functionality information. This signal has a weak internal pull-up.  <b>NOTE:</b> This signal should not be pulled low unless using XOR Chain testing.
GPIO33 / HDA_DOCK_EN#	Flash Descriptor Security Override Strap	Rising Edge of PWROK	This signal has a weak internal pull-up. If sampled low, the Flash Descriptor Security will be overridden. If high, the security measures defined in the Flash Descriptor will be in effect.  <b>NOTE:</b> This should only be used in manufacturing environments.

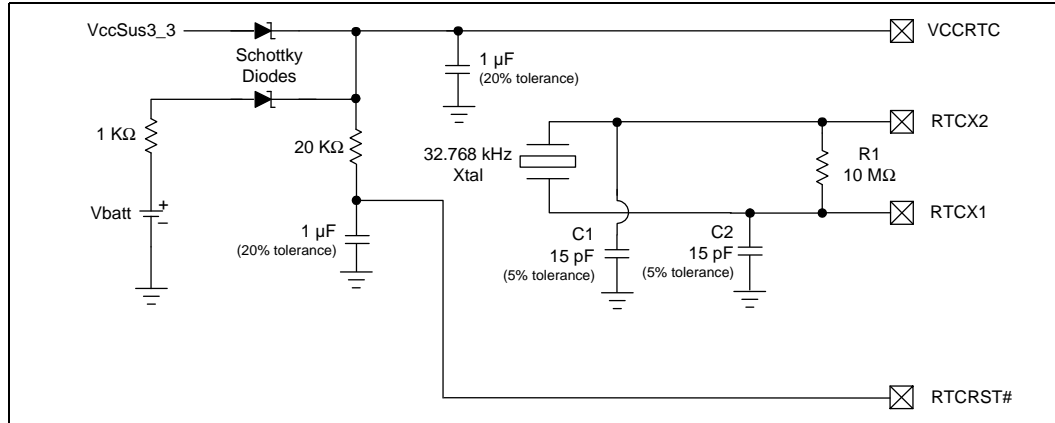
**NOTE:**

- See [Section 3.1](#) for full details on pull-up/pull-down resistors.
- When strapped, the SPI\_CS1# pin is required to be held at the strapped value for the minimum of 200 ns with respect to the rising edge of either the CLPWROK pin or the LAN\_RST# pin, whichever rises first. Note that the hold time is also required to meet the minimum of 101 ms after the RSMRST# pin is deasserted in the case both ICH8 ME well and AUX well are connected to the Resume Well power.

### 2.26.2 External RTC Circuitry

To reduce RTC well power consumption, the ICH8 implements an internal oscillator circuit that is sensitive to step voltage changes in VccRTC. Figure 3 shows an example schematic recommended to ensure correct operation of the ICH8 RTC.

Figure 3. Example External RTC Circuit



**NOTE:** C1 and C2 depend on crystal load.





## 3 Intel® ICH8 Pin States

### 3.1 Integrated Pull-Ups and Pull-Downs

Table 31. Integrated Pull-Up and Pull-Down Resistors

Signal	Resistor Ty	Nominal Val	Notes
DD[7]	Pull-down	15 kΩ	10
DDREQ	Pull-down	15 kΩ	10
HDA_BIT_CLK	Pull-Down	20 kΩ	1, 9
HDA_RST#	None	N/A	
HDA_SDIN[3:0]	Pull-down	20 kΩ	2
HDA_SDOUT	Pull-down	20 kΩ	3
HDA_SYNC	Pull-down	20 kΩ	2
GNT[3:0]	Pull-up	20 kΩ	3, 7
GPIO[20]	Pull-down	20 kΩ	3
GPIO33	Pull-up	20 kΩ	3
GPIO 48	Pull-Up	20 kΩ	3, 11
GPIO[18, 19, 21, 32, 35, 37]	Pull-Down	20 kΩ	3, 11
LAD[3:0]# / FHW[3:0]#	Pull-up	20 kΩ	3
LAN_RXD[2:0]	Pull-up	10 kΩ	4
LDRQ[0]	Pull-up	20 kΩ	3
LDRQ[1] / GPIO23	Pull-up	20 kΩ	3
PME#	Pull-up	20 kΩ	3
PWRBTN#	Pull-up	20 kΩ	3
SATALED#	Pull-up	15 kΩ	8
SPI_CS1#	Pull-up	20 kΩ	3
SPI_MISO	Pull-up	20 kΩ	3
TACH[3:0]	Pull-up	20 kΩ	3
SPKR	Pull-down	20 kΩ	2
TP3	Pull-up	20 kΩ	6
USB[9:0] [P,N]	Pull-down	15 kΩ	5

#### NOTES:

- Simulation data shows that these resistor values can range from 10 kΩ to 40 kΩ.
- Simulation data shows that these resistor values can range from 9 kΩ to 50 kΩ.
- Simulation data shows that these resistor values can range from 15 kΩ to 35 kΩ.
- Simulation data shows that these resistor values can range from 7.5kΩ to 16 kΩ.
- Simulation data shows that these resistor values can range from 14.25 kΩ to 24.8 kΩ.
- Simulation data shows that these resistor values can range from 10 kΩ to 30 kΩ.
- The pull-up or pull-down on this signal is only enabled at boot/reset for strapping function.
- Simulation data shows that these resistor values can range from 10 kΩ to 20 kΩ. The internal pull-up is only enabled during PLTRST# assertion.
- The pull-down on this signal is only enabled when in S3.
- Simulation data shows that these resistor values can range from 5.7 kΩ to 28.3 kΩ.
- The integrated resistors are disabled after PLTRST# de-assertion.



### 3.2 IDE Integrated Series Termination Resistors (Mobile Only)

Table 32 shows the ICH8M IDE signals that have integrated series termination resistors.

Table 32. IDE Series Termination Resistors

Signal	Integrated Series Termination Resistor Value
DD[15:0], DIOW#, DIOR#, DREQ, DDACK#, IORDY, DA[2:0], DCS1#, DCS3#, IDEIRQ	approximately 33 Ω (See Note)

**NOTE:** Simulation data indicates that the integrated series termination resistors are a nominal 33 Ω but can range from 21 Ω to 75 Ω.

### 3.3 Output and I/O Signals Planes and States

Table 33 and Table 34 shows the power plane associated with the output and I/O signals, as well as the state at various times. Within the table, the following terms are used:

- “High-Z”                      Tri-state. ICH8 not driving the signal high or low.
- “High”                         ICH8 is driving the signal to a logic 1.
- “Low”                         ICH8 is driving the signal to a logic 0.
- “Defined”                    Driven to a level that is defined by the function or external pull-up/pull-down resistor (will be high or low).
- “Undefined”                 ICH8 is driving the signal, but the value is indeterminate.
- “Driven”                      Will be high or low, will be allowed to change.
- “Running”                    Clock is toggling or signal is transitioning because function not stopping.
- “Off”                         The power plane is off; ICH8 is not driving when configured as an output or sampling when configured as an input.
- “Input”                        ICH8 is sampling and signal state determined by external driver.

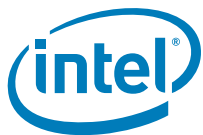
Note that the signal levels are the same in S4 and S5, except as noted.

ICH8 suspend well signal states are indeterminate and undefined and may glitch prior to RSMRST# deassertion. This does not apply to LAN\_RST#, SLP\_S3#, SLP\_S4#, SLP\_S5# and SLP\_M#. These signals are determinate and defined prior to RSMRST# deassertion.

ICH8 core well signal states are indeterminate and undefined and may glitch prior to PWROK assertion. This does not apply to FERR# and THRMTRIP#. These signals are determinate and defined prior to PWROK assertion.


**Table 33. Power Plane and States for Output and I/O Signals for Desktop Configurations (Sheet 1 of 5)**

Signal Name	Power Plane	During Reset <sup>4</sup>	Immediately after Reset <sup>4</sup>	S1	S3	S4/S5
<b>PCI Express*</b>						
PETp[6:1], PETn[6:1]	Core	High	High <sup>8</sup>	Defined	Off	Off
<b>DMI</b>						
DMI[3:0]TXP, DMI[3:0]TXN	Core	High	High <sup>8</sup>	Defined	Off	Off
<b>PCI Bus</b>						
AD[31:0]	Core	Low	Undefined	Defined	Off	Off
C/BE[3:0]#	Core	Low	Undefined	Defined	Off	Off
DEVSEL#	Core	High-Z	High-Z	High-Z	Off	Off
FRAME#	Core	High-Z	High-Z	High-Z	Off	Off
GNT0#, GNT[3:1]#/ GPIO[55, 53, 51]	Core	High-Z with Internal Pull-up	High	High	Off	Off
IRDY#, TRDY#	Core	High-Z	High-Z	High-Z	Off	Off
PAR	Core	Low	Undefined	Defined	Off	Off
PCIRST#	Suspend	Low	High	High	Low	Low
PERR#	Core	High-Z	High-Z	High-Z	Off	Off
PLOCK#	Core	High-Z	High-Z	High-Z	Off	Off
STOP#	Core	High-Z	High-Z	High-Z	Off	Off
<b>LPC Interface</b>						
LAD[3:0] / FWH[3:0]	Core	High	High	High	Off	Off
LFRAME# / FWH[4]	Core	High	High	High	Off	Off
<b>Platform LAN Connect Interface</b>						
LAN_RSTSYNC	LAN	High	Low	Defined	Off	Off
LAN_TXD[2:0]	LAN	Low	Low	Defined	Off	Off
<b>Gigabit LAN Connect Interface</b>						
GLAN_TXp, GLAN_TXn	GLAN	High	High	Defined	Off	Off
<b>SATA Interface</b>						
SATA[5:0]TXP, SATA[5:0]TXN	Core	High-Z	High-Z	Defined	Off	Off
SATALED#	Core	High-Z	High-Z	Defined	Off	Off
SATARBIAS	Core	High-Z	High-Z	High-Z	Off	Off



**Table 33. Power Plane and States for Output and I/O Signals for Desktop Configurations (Sheet 2 of 5)**

Signal Name	Power Plane	During Reset <sup>4</sup>	Immediately after Reset <sup>4</sup>	S1	S3	S4/S5
SATA5GP SATA4GP SATA3GP / GPIO37 SATA2GP / GPIO36 SATA1GP / GPIO19 SATA0GP / GPIO21	Core	Input	Input	Driven	Off	Off
SATACLKREQ# / GPIO35	Core	Low	Low	Defined	Off	Off
SCLOCK/GPIO22	Core	Input	Input	Defined	Off	Off
SLOAD/GPIO38	Core	Input	Input	Defined	Off	Off
SDATAOUT[1:0]/ GPIO[48,39]	Core	Input	Input	Defined	Off	Off
<b>Interrupts</b>						
PIRQ[A:D]#, PIRQ[H:E]# / GPIO[5:2]	Core	High-Z	High-Z	High-Z	Off	Off
SERIRQ	Core	High-Z	High-Z	High-Z	Off	Off


**Table 33. Power Plane and States for Output and I/O Signals for Desktop Configurations (Sheet 3 of 5)**

Signal Name	Power Plane	During Reset <sup>4</sup>	Immediately after Reset <sup>4</sup>	S1	S3	S4/S5
<b>USB Interface</b>						
USBP[9:0][P,N]	Suspend	Low	Low	Low	Low	Low
USBRBIAS	Suspend	High-Z	High-Z	Defined	Defined	Defined
<b>Power Management</b>						
PLTRST#	Suspend	Low	High	High	Low	Low
SLP_M <sup>9</sup>	Suspend	Low	High	High	Driven	Driven
SLP_S3#	Suspend	Low	High	High	Low	Low
SLP_S4#	Suspend	Low	High	High	High	Low
SLP_S5#	Suspend	Low	High	High	High	Low <sup>7</sup>
SUS_STAT#	Suspend	Low	High	High	Low	Low
SUSCLK	Suspend	Low	Running			
CK_PWRGD	Suspend	Low	High	Low	High	High
<b>Processor Interface</b>						
A20M#	CPU	Dependant on A20GATE Signal	See Note 1	High	Off	Off
CPUPWRGD / GPIO49	CPU	Defined	High	High	Off	Off
CPUSLP#	CPU	High	High	Defined	Off	Off
IGNNE#	CPU	High	See Note 1	High	Off	Off
INIT#	CPU	High	High	High	Off	Off
INIT3_3V#	Core	High	High	High	Off	Off
INTR	CPU	See Note 5	See Note 5	Low	Off	Off
NMI	CPU	See Note 5	See Note 5	Low	Off	Off
SMI#	CPU	High	High	High	Off	Off
STPCLK#	CPU	High	High	Low	Off	Off
<b>SMBus Interface</b>						
SMBCLK, SMBDATA	Suspend	High-Z	High-Z	Defined	Defined	Defined
<b>System Management Interface</b>						
CLGPIO0	Suspend	High-Z	High-Z	Defined	Defined	Defined
WOL_EN	Suspend	High-Z	High-Z	Defined	Defined	Defined
SMLINK[1:0]	Suspend	High-Z	High-Z	Defined	Defined	Defined
LINKALERT#	Suspend	High-Z	High-Z	Defined	Defined	Defined



**Table 33. Power Plane and States for Output and I/O Signals for Desktop Configurations (Sheet 4 of 5)**

Signal Name	Power Plane	During Reset <sup>4</sup>	Immediately after Reset <sup>4</sup>	S1	S3	S4/S5
<b>Miscellaneous Signals</b>						
SPKR	Core	High-Z with Internal Pull-down	Low	Defined	Off	Off
<b>Intel® High Definition Audio Interface</b>						
HDA_RST#	HDA Suspend	Low	Low <sup>8</sup>	Running	Low	Low
HDA_SDOOUT	HDA	High-Z with Internal Pull-down	Running	Low	Off	Off
HDA_SYNC	HDA	High-Z with Internal Pull-down	Running	Low	Off	Off
HDA_BIT_CLK	HDA	High-Z with Internal Pull-down	Low	Low	Off	Off
<b>Unmultiplexed GPIO Signals</b>						
GPIO0	Core	Input	Input	Driven	Off	Off
GPIO10	Suspend	High-Z	High-Z	Defined	Defined	Defined
GPIO[13, 12, 8]	Suspend	Input	Input	Driven	Driven	Driven
GPIO14	Suspend	High-Z	High-Z	Defined	Defined	Defined
GPIO15	Suspend	High	High	Defined	Defined	Defined
GPIO16	Core	Low	Low	Defined	Off	Off
GPIO18	Core	High	See Note 2	Defined	Off	Off
GPIO20	Core	High	High	Defined	Off	Off
GPIO25	Core	High	High	Defined	Off	Off
GPIO[33:32]	Core	High	High	Defined	Off	Off
GPIO34	Core	Low	Low	Defined	Off	Off
<b>SPI Interface</b>						
SPI_CS[1:0]#	Controller Link	High	High	High	Off	Off
SPI_MOSI	Controller Link	High	High	High	Off	Off
SPI_CLK	Controller Link	Low	Low	Low	Off	Off
<b>Intel® Quick Resume Technology Interface (Intel® ICH8DH Only)</b>						
QRT_STATE[1:0] / GPIO[28:27]	Suspend	Low	Low	Defined	Defined	Defined





**Table 33. Power Plane and States for Output and I/O Signals for Desktop Configurations (Sheet 5 of 5)**

Signal Name	Power Plane	During Reset <sup>4</sup>	Immediately after Reset <sup>4</sup>	S1	S3	S4/S5
<b>Controller Link</b>						
CL_CLK	Controller Link	Low	Low	Low	Off	Off
CL_DATA0	Controller Link	Low	Low	Low	Off	Off
CL_RST#	Suspend	Low	High	High	High	High
<b>Intel® Quiet System Technology (Desktop Only)</b>						
PWM[2:0]	Core	Low	Low	Defined	Off	Off
SST	Controller Link	Low	Low	Defined	Off	Off
PECI	CPU	Low	Low	Defined	Off	Off

**NOTES:**

1. ICH8 drives these signals High after the processor Reset
2. GPIO[18] will toggle at a frequency of approximately 1 Hz when the ICH8 comes out of reset
3. CPUPWRGD represents a logical AND of the ICH8's VRMPWRGD and PWROK signals, and thus will be driven low by ICH8 when either VRMPWRGD or PWROK are inactive. During boot, or during a hard reset with power cycling, CPUPWRGD will be expected to transition from low to High-Z.
4. The states of Core and processor signals are evaluated at the times During PLTRST# and Immediately after PLTRST#. The states of the LAN and GLAN signals are evaluated at the times During LAN\_RST# and Immediately after LAN\_RST#. The states of the Controller Link signals are taken at the times During CL\_RST# and Immediately after CL\_RST#. The states of the Suspend signals are evaluated at the times During RSMRST# and Immediately after RSMRST#. The states of the HDA signals are evaluated at the times During HDA\_RST# and Immediately after HDA\_RST#.
5. ICH8 drives these signals Low before PWROK rising and Low after the processor Reset.
6. SLP\_S5# signals will be high in the S4 state.
7. Low until Intel High Definition Audio Controller Reset bit set (D27:F0:Offset HDBAR+08h:bit 0), at which time HDA\_RST# will be High and HDA\_BIT\_CLK will be Running.
8. PETp/n[6:1] high until port is enabled by software.
9. The SLP\_M# state will be determined by Intel® AMT policies.



**Table 34. Power Plane and States for Output and I/O Signals for Mobile Configurations (Sheet 1 of 4)**

Signal Name	Power Plane	During Reset <sup>4</sup>	Immediately after Reset <sup>4</sup>	C3/C4	S1	S3	S4/S5
<b>PCI Express*</b>							
PETp[6:1], PETn[6:1]	Core	High	High <sup>9</sup>	Defined	Defined	Off	Off
<b>DMI</b>							
DMI[3:0]TXP, DMI[3:0]TXN	Core	High	High <sup>9</sup>	Defined	Defined	Off	Off
<b>PCI Bus</b>							
AD[31:0]	Core	Low	Undefined	Defined	Defined	Off	Off
C/BE[3:0]#	Core	Low	Undefined	Defined	Defined	Off	Off
CLKRUN#	Core	Low	Low	Defined		Off	Off
DEVSEL#	Core	High-Z	High-Z	High-Z	High-Z	Off	Off
FRAME#	Core	High-Z	High-Z	High-Z	High-Z	Off	Off
GNT0#, GNT[3:1]#/ GPIO[55, 53, 51]	Core	High with Internal Pull-ups	High	High	High	Off	Off
IRDY#, TRDY#	Core	High-Z	High-Z	High-Z	High-Z	Off	Off
PAR	Core	Low	Undefined	Defined	Defined	Off	Off
PCIRST#	Suspend	Low	High	High	High	Low	Low
PERR#	Core	High-Z	High-Z	High-Z	High-Z	Off	Off
PLOCK#	Core	High-Z	High-Z	High-Z	High-Z	Off	Off
STOP#	Core	High-Z	High-Z	High-Z	High-Z	Off	Off
<b>LPC Interface</b>							
LAD[3:0] / FWH[3:0]	Core	High	High	High	High	Off	Off
LFRAME# / FWH[4]	Core	High	High	High	High	Off	Off
<b>Platform LAN Connect Interface</b>							
LAN_RSTSYNC	LAN	High	Low	Defined	Defined	Off	Off
LAN_TXD[2:0]	LAN	Low	Low	Defined	Defined	Off	Off
<b>Gigabit LAN Connect Interface</b>							
GLAN_TXp, GLAN_TXn	GLAN	High	High	Defined	Defined	Off	Off
<b>IDE Interface</b>							
DA[2:0]	Core	Undefined	Undefined	Undefined	Undefined	Off	Off
DCS1#, DCS3#	Core	High	High	High	High	Off	Off
DD[15:8], DD[6:0]	Core	High-Z	High-Z	Defined	High-Z	Off	Off
DD[7]	Core	Low	Low	Defined	Low	Off	Off
DDACK#	Core	High	High	High	High	Off	Off
DIOR#, DIOW#	Core	High	High	High	High	Off	Off


**Table 34. Power Plane and States for Output and I/O Signals for Mobile Configurations (Sheet 2 of 4)**

Signal Name	Power Plane	During Reset <sup>4</sup>	Immediately after Reset <sup>4</sup>	C3/C4	S1	S3	S4/S5
<b>SATA Interface</b>							
SATA[2:0]TXP, SATA[2:0]TXN	Core	High-Z	High-Z	Defined	Defined	Off	Off
SATALED#	Core	High-Z	High-Z	Defined	Defined	Off	Off
SATARBIAS	Core	High-Z	High-Z	Defined	Defined	Off	Off
SATA2GP / GPIO36 SATA1GP / GPIO19 SATA0GP / GPIO21	Core	Input	Input	Driven	Driven	Off	Off
SATACLKREQ# / GPIO35	Core	Low	Low	Defined	Defined	Off	Off
<b>Interrupts</b>							
PIRQ[A:D]#, PIRQ[H:E]# / GPIO[5:2]	Core	High-Z	High-Z	Defined	High-Z	Off	Off
SERIRQ	Core	High-Z	High-Z	Running	High-Z	Off	Off
<b>USB Interface</b>							
USB[9:0][P,N]	Suspend	Low	Low	Low	Low	Low	Low
USBBIAS	Suspend	High-Z	High-Z	Defined	Defined	Defined	Defined
<b>Power Management</b>							
PLTRST#	Suspend	Low	High	High	High	Low	Low
SLP_M#	Suspend	Low	High	High	High	Driven	Driven
SLP_S3#	Suspend	Low	High	High	High	Low	Low
SLP_S4#	Suspend	Low	High	High	High	High	Low
SLP_S5#	Suspend	Low	High	High	High	High	Low <sup>8</sup>
STP_CPU#	Core	High	High	Defined	High	Off	Off
STP_PCI#	Core	High	High	Defined	High	Off	Off
SUS_STAT#	Suspend	Low	High	High	High	Low	Low
DPRSLPVR	Core	Low	Low	Low/ High <sup>4</sup>	High	Off	Off
DPRSTP#	Core	High	High	Low/ High <sup>4</sup>	High	Off	Off
SUSCLK	Suspend	Low	Running				
CK_PWRGD	Suspend	Low	High	Low	Low	High	High
<b>Processor Interface</b>							
A20M#	CPU	Dependant on A20GATE Signal	See Note 1	Defined	High	Off	Off
CPUPWRGD / GPIO49	CPU	See Note 3	High	High	High	Off	Off
IGNNE#	CPU	High	See Note 1	High	High	Off	Off
INIT#	CPU	High	High	High	High	Off	Off



**Table 34. Power Plane and States for Output and I/O Signals for Mobile Configurations (Sheet 3 of 4)**

Signal Name	Power Plane	During Reset <sup>4</sup>	Immediately after Reset <sup>4</sup>	C3/C4	S1	S3	S4/S5
INTR	CPU	See Note 6	See Note 6	Defined	Low	Off	Off
NMI	CPU	See Note 6	See Note 6	Defined	Low	Off	Off
SMI#	CPU	High	High	Defined	High	Off	Off
STPCLK#	CPU	High	High	Low	Low	Off	Off
DPSLP#	CPU	High	High	High/Low	High	Off	Off
<b>SMBus Interface</b>							
SMBCLK, SMBDATA	Suspend	High-Z	High-Z	Defined	Defined	Defined	Defined
<b>System Management Interface</b>							
CLGPIO0/GPIO24	Suspend	High-Z	High-Z	Defined	Defined	Defined	Defined
ALERT#/GPIO10	Suspend	High-Z	High-Z	Defined	Defined	Defined	Defined
NETDETECT/GPIO14	Suspend	High-Z	High-Z	Defined	Defined	Defined	Defined
WOL_EN/GPIO9	Suspend	High-Z	High-Z	Defined	Defined	Defined	Defined
SMLINK[1:0]	Suspend	High-Z	High-Z	Defined	Defined	Defined	Defined
LINKALERT#	Suspend	High-Z	High-Z	Defined	Defined	Defined	Defined
<b>Miscellaneous Signals</b>							
SPKR	Core	High-Z with Internal Pull-down	Low	Defined	Defined	Off	Off
<b>Intel® High Definition Audio Interface</b>							
HDA_RST#	HDA Suspend	Low	Low <sup>8</sup>	High	TBD	Low	Low
HDA_SDOOUT	HDA	High-Z with Internal Pull-down	Running	Running	Low	Off	Off
HDA_SYNC	HDA	High-Z with Internal Pull-down	Running	Running	Low	Off	Off
HDA_BIT_CLK	HDA	High-Z with Internal Pull-down	Low <sup>8</sup>	Running	Low	Off	Off
HDA_DOCK_RST# / GPIO34	HDA Suspend	Low	Low <sup>9</sup>	Defined	Defined	Off	Off
HDA_DOCK_EN# / GPIO33	HDA	High	High	Defined	Defined	Off	Off
<b>Unmultiplexed GPIO Signals</b>							
GPIO[12, 8]	Suspend	Input	Input	Driven	Driven	Driven	Driven
GPIO18	Core	High	See Note 2	Driven	Driven	Off	Off
GPIO20	Core	High	High	Defined	Defined	Off	Off



**Table 34. Power Plane and States for Output and I/O Signals for Mobile Configurations (Sheet 4 of 4)**

Signal Name	Power Plane	During Reset <sup>4</sup>	Immediately after Reset <sup>4</sup>	C3/C4	S1	S3	S4/S5
<b>SPI Interface</b>							
SPI_CS[1:0]#	Controller Link	High	High	High	High	Off	Off
SPI_MOSI	Controller Link	High	High	High	High	Off	Off
SPI_CLK	Controller Link	Low	Low	Low	Low	Off	Off
<b>Controller Link</b>							
CL_CLK 0 CL_DATA 0	Controller Link	Low	Low	Low	Low	Off	Off
CL_CLK 1 CL_DATA 1	Suspend	Low	Low	Low	Low	Off	Off
CL_RST#	Suspend	Low	High	High	High	High	High

**NOTES:**

1. ICH8 drives these signals High after the CPU Reset
2. GPIO[18] will toggle at a frequency of approximately 1 Hz when the ICH8 comes out of reset
3. CPUPWRGD represents a logical AND of the ICH8's VRMPWRGD and PWROK signals, and thus will be driven low by ICH8 when either VRMPWRGD or PWROK are inactive. During boot, or during a hard reset with power cycling, CPUPWRGD will be expected to transition from low to High-Z.
4. The states of Core and processor signals are evaluated at the times During PLTRST# and Immediately after PLTRST#. The states of the LAN and GLAN signals are evaluated at the times During LAN\_RST# and Immediately after LAN\_RST#. The states of the Controller Link signals are evaluated at the times During CL\_RST# and Immediately after CL\_RST#. The states of the Suspend signals are evaluated at the times During RSMRST# and Immediately after RSMRST#. The states of the HDA signals are evaluated at the times During HDA\_RST# and Immediately after HDA\_RST#.
5. ICH8 drives these signals Low before PWROK rising and Low after the processor Reset.
6. SLP\_S5# signals will be high in the S4 state.
7. Low until Intel High Definition Audio Controller Reset bit set (D27:F0:Offset HDBAR+08h:bit 0), at which time HDA\_RST# will be High and HDA\_BIT\_CLK will be Running.
8. PETp/n[6:1] high until port is enabled by software.
9. The SLP\_M# state will be determined by AMT policies



### 3.4 Power Planes for Input Signals

Table 35 and Table 36 shows the power plane associated with each input signal, as well as what device drives the signal at various times. Valid states include:

- High
- Low
- Static: Will be high or low, but will not change
- Driven: Will be high or low, and is allowed to change
- Running: For input clocks

**Table 35. Power Plane for Input Signals for Desktop Configurations (Sheet 1 of 3)**

Signal Name	Power Well	Driver During Reset	S1	S3	S4/S5
<b>DMI</b>					
DMI_CLKP, DMI_CLKN	Core	Clock Generator	Running	Off	Off
DMI[3:0]RXP, DMI[3:0]RXN	Core	(G)MCH	Driven	Off	Off
<b>PCI Express*</b>					
PERp[6:1], PERn[6:1]	Core	PCI Express* Device	Driven	Off	Off
<b>PCI Bus</b>					
REQ0#, REQ1# / GPIO50 <sup>1, 3</sup> REQ2# / GPIO52 <sup>1, 3</sup> REQ3# / GPIO54 <sup>1, 3</sup>	Core	External Pull up	Driven	Off	Off
PCICLK	Core	Clock Generator	Running	Off	Off
PME#	Suspend	Internal Pull-up	Driven	Driven	Driven
SERR#	Core	PCI Bus Peripherals	High	Off	Off
<b>LPC Interface</b>					
LDRQ0#	Core	LPC Devices	High	Off	Off
LDRQ1# / GPIO23 <sup>2</sup>	Core	LPC Devices	High	Off	Off
<b>Platform LAN Connect Interface</b>					
GLAN_CLK	Suspend	LAN Connect Component	Driven	Driven	Driven
LAN_RXD[2:0]	Suspend	LAN Connect Component	Driven	Driven	Driven
<b>Gigabit LAN Connect Interface</b>					
GLAN_RXp GLAN_RXn	Suspend	Gigabit Lan Connect Component	Driven	Driven	Driven
<b>SATA Interface</b>					
SATA_CLKP, SATA_CLKN	Core	Clock Generator	Running	Off	Off
SATA[3:0]RXP, SATA[3:0]RXN	Core	SATA Drive	Driven	Off	Off
SATARBIAS#	Core	External Pull-down	Driven	Off	Off
SATA[5:4]GP SATA[3:0]GP / GPIO[37,36,19] <sup>1</sup>	Core	External Device or External Pull-up/Pull-down	Driven	Off	Off
<b>USB Interface</b>					



Table 35. Power Plane for Input Signals for Desktop Configurations (Sheet 2 of 3)

Signal Name	Power Well	Driver During Reset	S1	S3	S4/S5
OCO#, OC[7:1]# / GPIO[31, 30, 29, 43, 42,41, 40], OC[9:8]#	Suspend	External Pull-ups	Driven	Driven	Driven
USBRBIAS#	Suspend	External Pull-down	Driven	Driven	Driven
<b>Power Management</b>					
CLPWROK	Suspend	External Circuit	Driven	Driven	Driven
LAN_RST#	Suspend	External Circuit	High	High	High
MCH_SYNC#	Core	(G)MCH	Driven	Off	Off
PWRBTN#	Suspend	Internal Pull-up	Driven	Driven	Driven
PWROK	RTC	System Power Supply	Driven	Off	Off
RI#	Suspend	Serial Port Buffer	Driven	Driven	Driven
RSMRST#	Suspend	External RC Circuit	High	High	High
SYS_RESET#	Suspend	External Circuit	Driven	Driven	Driven
THRM#	Core	Thermal Sensor	Driven	Off	Off
THRMTRIP#	Core	Thermal Sensor	Driven	Off	Off
VRMPWRGD	Suspend	Processor Voltage Regulator	High	Low	Low
WAKE#	Suspend	External Pull-up	Driven	Driven	Driven
<b>Processor Interface</b>					
A2OGATE	Core	External Microcontroller	Static	Off	Off
FERR#	Core	Processor	Static	Off	Off
RCIN#	Core	External Microcontroller	High	Off	Off
<b>SMBus Interface</b>					
SMBALERT# / GPIO11 <sup>1</sup>	Suspend	External Pull-up	Driven	Driven	Driven
<b>System Management Interface</b>					
INTRUDER#	RTC	External Switch	Driven	High	High
<b>Miscellaneous Signals</b>					
INTVRMEN	RTC	External Pull-up	High	High	High
LAN100_SLP	RTC	External Pull-up	High	High	High
RTCST#	RTC	External RC Circuit	High	High	High
TP[0]	Suspend	External Pull-up	High	High	High
TP[3]	Suspend	Internal Pull-up	High	High	High
<b>Intel® High Definition Audio Interface</b>					
HDA_SDIN[3:0]	Suspend	Intel® High Definition Audio Codec	Low	Low	Low



**Table 35. Power Plane for Input Signals for Desktop Configurations (Sheet 3 of 3)**

Signal Name	Power Well	Driver During Reset	S1	S3	S4/S5
<b>SPI Interface</b>					
SPI_MISO	Suspend	Internal Pull-up	Driven	Driven	Driven
<b>Fan Speed Control</b>					
TACH[3:0]/ GPIO[7,6,1,17] <sup>1</sup>	Core	External Pull-up	Driven	Off	Off
<b>Clocks</b>					
CLK14	Core	Clock Generator	Running	Off	Off
CLK48	Core	Clock Generator	Running	Off	Off

**NOTES:**

1. These signals can be configured as outputs in GPIO mode.
2. The state of the DPRSLPVR and DPRSTP# signals in C4 are high if Deeper Sleep is enabled or low if it is disabled.
3. GPIO50, GPIO52, GPIO54 need to be glitch free immediately after Reset to when they are being initialized to GPIO. Multiplexed GPIO signals defaulting to a native function must be glitch free immediately after Reset until the time they are initialized as GPIO.

**Table 36. Power Plane for Input Signals for Mobile Configurations (Sheet 1 of 3)**

Signal Name	Power Well	Driver During Reset	C3/C4	S1	S3	S4/S5
<b>DMI</b>						
DMI_CLKP DMI_CLKN	Core	Clock Generator	Running	Running	Off	Off
DMI[3:0]RXP, DMI[3:0]RXN	Core	(G)MCH	Driven	Driven	Off	Off
<b>PCI Express</b>						
PERp[6:1], PERn[6:1]	Core	PCI Express* Device	Driven	Driven	Off	Off
<b>PCI Bus</b>						
PCICLK	Core	Clock Generator	Running	Running	Off	Off
PME#	Suspend	Internal Pull-up	Driven	Driven	Driven	Driven
REQ0#, REQ1/GPIO50 <sup>1, 3</sup> , REQ2/GPIO52 <sup>1, 3</sup> , REQ3/GPIO53 <sup>1, 3</sup>	Core	External Pull up	Driven	Driven	Off	Off
SERR#	Core	PCI Bus Peripherals	Driven	High	Off	Off
<b>LPC Interface</b>						
LDRQ0#	Core	LPC Devices	Driven	High	Off	Off
LDRQ1# / GPIO23 <sup>1</sup>	Core	LPC Devices	Driven	High	Off	Off
<b>Platform LAN Connect Interface</b>						
GLAN_CLK	Suspend	LAN Connect Component	Driven	Driven	Driven	Driven





Table 36. Power Plane for Input Signals for Mobile Configurations (Sheet 2 of 3)

Signal Name	Power Well	Driver During Reset	C3/C4	S1	S3	S4/S5
LAN_RXD[2:0]	Suspend	LAN Connect Component	Driven	Driven	Driven	Driven
<b>Gigabit LAN Connect Interface</b>						
GLAN_RXp GLAN_RXn	Suspend	Gigabit Lan Connect Component	Driven	Driven	Driven	Driven
<b>SATA Interface</b>						
SATA_CLKP, SATA_CLKN	Core	Clock Generator	Running	Running	Off	Off
SATA[2:0]RXP, SATA[2:0]RXN	Core	SATA Drive	Driven	Driven	Off	Off
SATARBIAS#	Core	External Pull-Down	Driven	Driven	Off	Off
SATA[5:4]GP SATA[3:0]GP / GPIO[37, 36, 19] <sup>1</sup>	Core	External Device or External Pull-up/Pull-down	Driven	Driven	Off	Off
<b>IDE Interface</b>						
DDREQ	Core	IDE Device	Driven	Static	Off	Off
IDEIRQ	Core	IDE	Driven	Static	Off	Off
IORDY	Core	IDE Device	Static	Static	Off	Off
<b>USB Interface</b>						
OC0#, OC[7:1]# / GPIO[31, 30, 29, 43, 42,41, 40], OC[9:8]#	Suspend	External Pull-ups	Driven	Driven	Driven	Driven
USBRBIAS#	Suspend	External Pull-down	Driven	Driven	Driven	Driven
<b>Power Management</b>						
BMBUSY# /GPIO0 <sup>1</sup>	Core	Graphics Component [(G)MCH]	Driven	High	Off	Off
CLPWROK	Suspend	External Circuit	Driven	Driven	Driven	Driven
LAN_RST#	Suspend	Power Supply	High	High	Static	Static
MCH_SYNC#	Core	(G)MCH	Driven	Driven	Off	Off
PWRBTN#	Suspend	Internal Pull-up	Driven	Driven	Driven	Driven
PWROK	RTC	System Power Supply	Driven	Driven	Off	Off
RI#	Suspend	Serial Port Buffer	Driven	Driven	Driven	Driven
RSMRST#	Suspend	External RC Circuit	High	High	High	High
SYS_RESET#	Suspend	External Circuit	Driven	Driven	Driven	Driven
THRM#	Core	Thermal Sensor	Driven	Driven	Off	Off
THRMTRIP#	Core	Thermal Sensor	Driven	Driven	Off	Off
VRMPWRGD	Suspend	Processor Voltage Regulator	Driven	Driven	Low	Low
WAKE#	Suspend	External Pull-up	Driven	Driven	Driven	Driven



Table 36. Power Plane for Input Signals for Mobile Configurations (Sheet 3 of 3)

Signal Name	Power Well	Driver During Reset	C3/C4	S1	S3	S4/S5
<b>Processor Interface</b>						
A20GATE	Core	External Microcontroller	Static	Static	Off	Off
FERR#	Core	Processor	Static	Static	Off	Off
RCIN#	Core	External Microcontroller	High	High	Off	Off
<b>SMBus Interface</b>						
SMBALERT# / GPIO11 <sup>1</sup>	Suspend	External Pull-up	Driven	Driven	Driven	Driven
<b>System Management Interface</b>						
INTRUDER#	RTC	External Switch	Driven	Driven	High	High
<b>Miscellaneous Signals</b>						
BATLOW#	Suspend	Power Supply	High	High	High	High
INTVRMEN	RTC	External Pull-up	High	High	High	High
LAN100_SLP	RTC	External Pull-up	High	Driven	High	High
RTCST#	RTC	External RC Circuit	High	High	High	High
TP[3]	Suspend	Internal Pull-up	High	High	High	High
<b>Intel® High Definition Audio Interface</b>						
HDA_SDIN[3:0]	Suspend	Intel® High Definition Audio Codec	Driven	Low	Low	Low
<b>SPI Interface</b>						
SPI_MISO	Suspend	Internal Pull-up	Driven	Driven	Driven	Driven
<b>Clocks</b>						
CLK14	Core	Clock Generator	Running	Running	Off	Off
CLK48	Core	Clock Generator	Running	Running	Off	Off

**NOTE:**

1. These signals can be configured as outputs in GPIO mode.
2. The state of the DPRSLPVR and DPRSTP# signals in C4 are high if Deeper Sleep is enabled or low if it is disabled.
3. GPIO50, GPIO52, GPIO54 need to be glitch free immediately after Reset to when they are being initialized to GPIO. Multiplexed GPIO signals defaulting to a native function must be glitch free immediately after Reset until the time they are initialized as GPIO.





## 4 Intel® ICH8 and System Clock Domains

Table 37 shows the system clock domains. Figure 4 and Figure 5 shows the assumed connection of the various system components, including the clock generator in both desktop and mobile systems. For complete details of the system clocking solution, refer to the system's clock generator component specification.

**Table 37. Intel® ICH8 and System Clock Domains**

Clock Domain	Frequency	Source	Usage
ICH8 SATA_CLKP, SATA_CLKN	100 MHz	Main Clock Generator	Differential clock pair used for SATA.
ICH8 DMI_CLKP, DMI_CLKN	100 MHz	Main Clock Generator	Differential clock pair used for DMI.
ICH8 PCICLK	33 MHz	Main Clock Generator	Free-running PCI Clock to Intel® ICH8. This clock remains on during S0 and S1 (in desktop) state, and is expected to be shut off during S3 or below in desktop configurations or S1 or below in mobile configurations.
System PCI	33 MHz	Main Clock Generator	PCI Bus, LPC Interface. These clocks only go to external PCI and LPC devices. These clocks will stop based on CLKRUN# (and STP_PCI#) in mobile configurations.
ICH8 CLK48	48.000 MHz	Main Clock Generator	Super I/O, USB controllers. This clock is expected to be shut off during S3 or below in desktop configurations or S1 or below in mobile configurations.
ICH8 CLK14	14.31818 MHz	Main Clock Generator	Used for ACPI timer and Multimedia Timers. This clock is expected to be shut off during S3 or below in desktop configurations or S1 or below in mobile configurations.
GLAN_CLK	5 to 62.5 MHz	LAN Connect Component	Generated by the LAN Connect component. This clock is expected to be shut off during S3 or below in desktop configurations or S1 or below in mobile configurations.
SPI_CLK	17.86 MHz/ 31.25 MHz	ICH8	Generated by the ICH8. This clock is expected to be shut off during S3 or below in desktop configurations or S1 or below in mobile configurations.

Figure 4. Desktop Conceptual System Clock Diagram

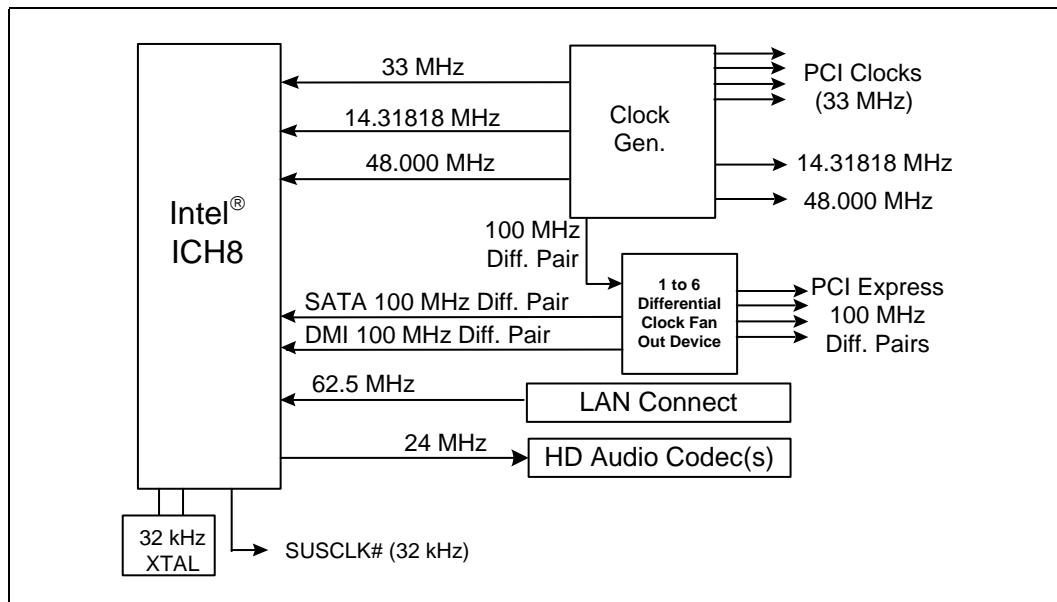
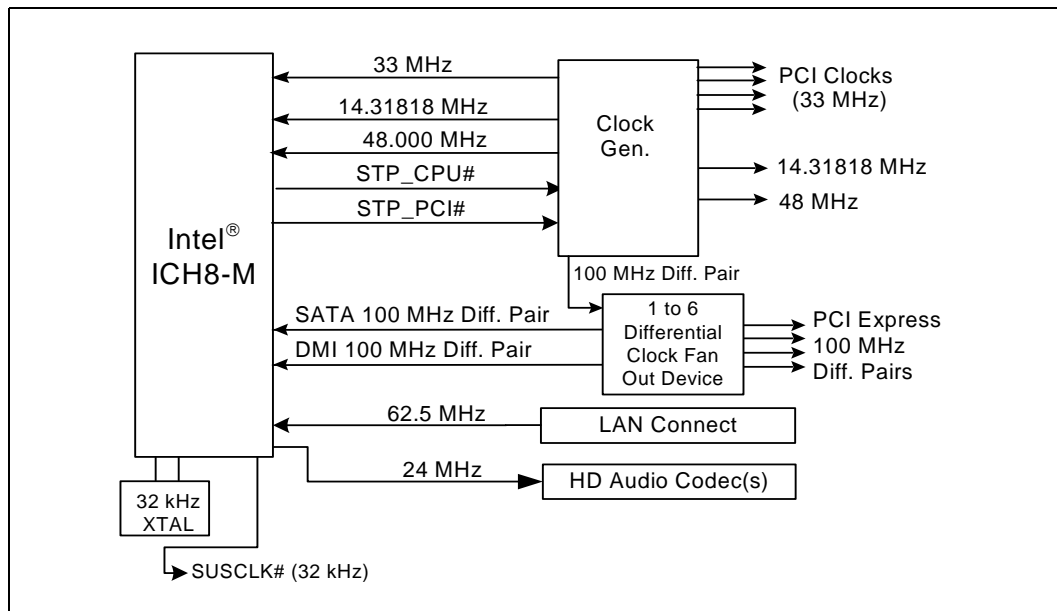


Figure 5. Mobile Conceptual Clock Diagram



§ §



## 5 Functional Description

This chapter describes the functions and interfaces of the ICH8 family.

### 5.1 PCI-to-PCI Bridge (D30:F0)

The PCI-to-PCI bridge resides in PCI Device 30, Function 0 on bus #0. This portion of the ICH8 implements the buffering and control logic between PCI and Direct Media Interface (DMI). The arbitration for the PCI bus is handled by this PCI device. The PCI decoder in this device must decode the ranges for the DMI. All register contents are lost when core well power is removed.

Direct Media Interface (DMI) is the chip-to-chip connection between the Memory Controller Hub / Graphics and Memory Controller Hub ((G)MCH) and I/O Controller Hub 8 (ICH8). This high-speed interface integrates advanced priority-based servicing allowing for concurrent traffic and true isochronous transfer capabilities. Base functionality is completely software transparent permitting current and legacy software to operate normally.

In order to provide for true isochronous transfers and configurable Quality of Service (QoS) transactions, the ICH8 supports two virtual channels on DMI: VC0 and VC1. These two channels provide a fixed arbitration scheme where VC1 is always the highest priority. VC0 is the default conduit of traffic for DMI and is always enabled. VC1 must be specifically enabled and configured at both ends of the DMI link (i.e., the ICH8 and (G)MCH).

Configuration registers for DMI, virtual channel support, and DMI active state power management (ASPM) are in the RCRB space in the Chipset Config Registers (Section 7).

#### 5.1.1 PCI Bus Interface

The ICH8 PCI interface supports *PCI Local Bus Specification, Revision 2.3*, at 33 MHz. The ICH8 integrates a PCI arbiter that supports up to four external PCI bus masters in addition to the internal ICH8 requests.

#### 5.1.2 PCI Bridge As an Initiator

The bridge initiates cycles on the PCI bus when granted by the PCI arbiter. The bridge generates the following cycle types:

**Table 38. PCI Bridge Initiator Cycle Types**

Command	C/BE#	Notes
I/O Read/Write	2h/3h	Non-posted
Memory Read/Write	6h/7h	Writes are posted
Configuration Read/Write	Ah/Bh	Non-posted
Special Cycles	1h	Posted



### 5.1.2.1 Memory Reads and Writes

The bridge bursts memory writes on PCI that are received as a single packet from DMI.

#### I/O Reads and Writes

The bridge generates single DW I/O read and write cycles. When the cycle completes on PCI bus, the bridge generates a corresponding completion on DMI. If the cycle is retried, the cycle is kept in the down bound queue and may be passed by a postable cycle.

### 5.1.2.2 Configuration Reads and Writes

The bridge generates single DW configuration read and write cycles. When the cycle completes on PCI bus, the bridge generates a corresponding completion. If the cycle is retried, the cycle is kept in the down bound queue and may be passed by a postable cycle.

### 5.1.2.3 Locked Cycles

The bridge propagates locks from DMI per the *PCI Local Bus Specification*. The PCI bridge implements bus lock, which means the arbiter will not grant to any agent except DMI while locked.

If a locked read results in a target or master abort, the lock is not established (as per the *PCI Local Bus Specification*). Agents north of the ICH8 must not forward a subsequent locked read to the bridge if they see the first one finish with a failed completion.

### 5.1.2.4 Target / Master Aborts

When a cycle initiated by the bridge is master/target aborted, the bridge will not re-attempt the same cycle. For multiple DW cycles, the bridge increments the address and attempts the next DW of the transaction. For all non-postable cycles, a target abort response packet is returned for each DW that was master or target aborted on PCI. The bridge drops posted writes that abort.

### 5.1.2.5 Secondary Master Latency Timer

The bridge implements a Master Latency Timer via the SLT register which, upon expiration, causes the de-assertion of FRAME# at the next valid clock edge when there is another active request to use the PCI bus.

### 5.1.2.6 Dual Address Cycle (DAC)

The bridge will issue full 64-bit dual address cycles for device memory-mapped registers above 4 GB.



### 5.1.2.7 Memory and I/O Decode to PCI

The PCI bridge in the ICH8 is a **subtractive decode agent**, which follows the following rules when forwarding a cycle from DMI to the PCI interface:

- The PCI bridge will **positively** decode any memory/IO address within its window registers, assuming PCICMD.MSE (D30:F0:Offset 04h:bit 1) is set for memory windows and PCICMD.IOSE (D30:F0:Offset 04h:bit 0) is set for IO windows.
- The PCI bridge will **subtractively** decode any 64-bit memory address not claimed by another agent, assuming PCICMD.MSE (D30:F0:Offset 04h:bit 1) is set.
- The PCI bridge will **subtractively** decode any 16-bit I/O address not claimed by another agent assuming PCICMD.IOSE (D30:F0:Offset 04h:bit 0) set
- If BCTRL.IE (D30:F0:Offset 3Eh:bit 2) is set, the PCI bridge will **not positively** forward from primary to secondary called out ranges in the IO window per *PCI Local Bus Specification* (I/O transactions addressing the last 768 bytes in each, 1-KB block: offsets 100h to 3FFh). The PCI bridge will still take them subtractively assuming the above rules.
- If BCTRL.VGAE (D30:F0:Offset 3Eh:bit 3) is set, the PCI bridge will **positively** forward from primary to secondary I/O and memory ranges as called out in the *PCI Bridge Specification*, assuming the above rules are met.

### 5.1.3 Parity Error Detection and Generation

PCI parity errors can be detected and reported. The following behavioral rules apply:

- When a parity error is detected on PCI, the bridge sets the SECSTS.DPE (D30:F0:Offset 1Eh:bit 15).
- If the bridge is a master and BCTRL.PERE (D30:F0:Offset 3Eh:bit 0) and one of the parity errors defined below is detected on PCI, then the bridge will set SECSTS.DPD (D30:F0:Offset 1Eh:bit 8) and will also generate an internal SERR#.
  - During a write cycle, the PERR# signal is active, or
  - A data parity error is detected while performing a read cycle
- If an address or command parity error is detected on PCI and PCICMD.SEE (D30:F0:Offset 04h:bit 8), BCTRL.PERE, and BCTRL.SEE (D30:F0:Offset 3Eh:bit 1) are all set, the bridge will set the PSTS.SSE (D30:F0:Offset 06h:bit 14) and generate an internal SERR#.
- If the PSTS.SSE is set because of an address parity error and the PCICMD.SEE is set, the bridge will generate an internal SERR#
- When bad parity is detected from DMI, bad parity will be driven on all data the bridge.
- When an address parity error is detected on PCI, the PCI bridge will never claim the cycle. This is a slight deviation from the PCI bridge spec, which says that a cycle should be claimed if BCTRL.PERE is not set. However, DMI does not have a concept of address parity error, so claiming the cycle could result in the rest of the system seeing a bad transaction as a good transaction.

### 5.1.4 PCIRST#

The PCIRST# pin is generated under two conditions:

- PLTRST# active
- BCTRL.SBR (D30:F0:Offset 3Eh:bit 6) set to 1

The PCIRST# pin is in the resume well. PCIRST# should be tied to PCI bus agents, but not other agents in the system.

### 5.1.5 Peer Cycles

The PCI bridge may be the initiator of peer cycles. Peer cycles include memory, IO, and configuration cycle types. Peer cycles are only allowed through VC0, and are enabled with the following bits:

- BPC.PDE (D30:F0:Offset 4Ch:bit 2) – Memory and I/O cycles
- BPC.CDE (D30:F0:Offset 4Ch:bit 1) – Configuration cycles

When enabled for peer for one of the above cycle types, the PCI bridge will perform a peer decode to see if a peer agent can receive the cycle. When not enabled, memory cycles (posted and/or non-posted) are sent to DMI, and I/O and/or configuration cycles are not claimed.

Configuration cycles have special considerations. Under the *PCI Local Bus Specification*, these cycles are not allowed to be forwarded upstream through a bridge. However, to enable things such as manageability, BPC.CDE can be set. When set, type 1 cycles are allowed into the part. The address format of the type 1 cycle is slightly different from a standard PCI configuration cycle to allow addressing of extended PCI space. The format is as follows:

**Table 39. Type 1 Address Format**

Bits	Definition
31:27	Reserved (same as the <i>PCI Local Bus Specification</i> )
26:24	Extended Configuration Address – allows addressing of up to 4K. These bits are combined with bits 7:2 to get the full register.
23:16	Bus Number (same as the <i>PCI Local Bus Specification</i> )
15:11	Device Number (same as the <i>PCI Local Bus Specification</i> )
10:8	Function Number (same as the <i>PCI Local Bus Specification</i> )
7:2	Register (same as the <i>PCI Local Bus Specification</i> )
1	0
0	Must be 1 to indicate a type 1 cycle. Type 0 cycles are not decoded.

**Note:** The ICH8's IDE (Mobile only) and USB controllers cannot perform peer-to-peer traffic.

### 5.1.6 PCI-to-PCI Bridge Model

From a software perspective, the ICH8 contains a PCI-to-PCI bridge. This bridge connects DMI to the PCI bus. By using the PCI-to-PCI bridge software model, the ICH8 can have its decode ranges programmed by existing plug-and-play software such that PCI ranges do not conflict with graphics aperture ranges in the Host controller.

### 5.1.7 IDSEL to Device Number Mapping

When addressing devices on the external PCI bus (with the PCI slots), the ICH8 asserts one address signal as an IDSEL. When accessing device 0, the ICH8 asserts AD16. When accessing Device 1, the ICH8 asserts AD17. This mapping continues all the way up to device 15 where the ICH8 asserts AD31. Note that the ICH8's internal functions (Intel High Definition Audio, IDE (Mobile only), USB, SATA and PCI Bridge) are enumerated like they are off of a separate PCI bus (DMI) from the external PCI bus.





## 5.1.8 Standard PCI Bus Configuration Mechanism

The PCI Bus defines a slot based “configuration space” that allows each device to contain up to eight functions with each function containing up to 256, 8-bit configuration registers. The *PCI Local Bus Specification, Revision 2.3* defines two bus cycles to access the PCI configuration space: Configuration Read and Configuration Write. Memory and I/O spaces are supported directly by the processor. Configuration space is supported by a mapping mechanism implemented within the ICH8. The *PCI Local Bus Specification, Revision 2.3* defines two mechanisms to access configuration space, Mechanism 1 and Mechanism 2. The ICH8 only supports Mechanism 1.

**Warning:** Configuration writes to internal devices, when the devices are disabled, are invalid and may cause undefined results.

## 5.2 PCI Express\* Root Ports (D28:F0,F1,F2,F3,F4,F5)

There are six root ports available in ICH8. These all reside in device 28, and take function 0 – 5. Port 1 is function 0, port 2 is function 1, port 3 is function 2, port 4 is function 3, port 5 is function 4, and port 6 is function 5.

### 5.2.1 Interrupt Generation

The root port generates interrupts on behalf of Hot-Plug and power management events, when enabled. These interrupts can either be pin based, or can be MSIs, when enabled.

When an interrupt is generated via the legacy pin, the pin is internally routed to the ICH8 interrupt controllers. The pin that is driven is based upon the setting of the chipset configuration registers. Specifically, the chipset configuration registers used are the D28IP (Base address + 310Ch) and D28IR (Base address + 3146h) registers.

Table 40 summarizes interrupt behavior for MSI and wire-modes. In the table “bits” refers to the Hot-Plug and PME interrupt bits.

**Table 40. MSI vs. PCI IRQ Actions**

Interrupt Register	Wire-Mode Action	MSI Action
All bits 0	Wire inactive	No action
One or more bits set to 1	Wire active	Send message
One or more bits set to 1, new bit gets set to 1	Wire active	Send message
One or more bits set to 1, software clears some (but not all) bits	Wire active	Send message
One or more bits set to 1, software clears all bits	Wire inactive	No action
Software clears one or more bits, and one or more bits are set on the same clock	Wire active	Send message

## 5.2.2 Power Management

### 5.2.2.1 S3/S4/S5 Support

Software initiates the transition to S3/S4/S5 by performing an IO write to the Power Management Control register in the ICH8. After the IO write completion has been returned to the processor, each root port will send a PME\_Turn\_Off TLP (Transaction Layer Packet) message on its downstream link. The device attached to the link will eventually respond with a PME\_TO\_Ack TLP message followed by sending a PM\_Enter\_L23 DLLP (Data Link Layer Packet) request to enter the L2/L3 Ready state. When all of the ICH8 root ports links are in the L2/L3 Ready state, the ICH8 power management control logic will proceed with the entry into S3/S4/S5.

Prior to entering S3, software is required to put each device into D3<sub>HOT</sub>. When a device is put into D3<sub>HOT</sub> it will initiate entry into a L1 link state by sending a PM\_Enter\_L1 DLLP. Thus under normal operating conditions when the root ports sends the PME\_Turn\_Off message the link will be in state L1. However, when the root port is instructed to send the PME\_Turn\_Off message, it will send it whether or not the link was in L1. Endpoints attached to the ICH8 can make no assumptions about the state of the link prior to receiving a PME\_Turn\_Off message.

### 5.2.2.2 Resuming from Suspended State

The root port contains enough circuitry in the resume well to detect a wake event through the WAKE# signal and to wake the system. When WAKE# is detected asserted, an internal signal is sent to the power management controller of the ICH8 to cause the system to wake up. This internal message is not logged in any register, nor is an interrupt/GPE generated due to it.

### 5.2.2.3 Device Initiated PM\_PME Message

When the system has returned to a working state from a previous low power state, a device requesting service will send a PM\_PME message continuously, until acknowledge by the root port. The root port will take different actions depending upon whether this is the first PM\_PME has been received, or whether a previous message has been received but not yet serviced by the operating system.

If this is the first message received (RSTS.PS - D28:F0/F1/F2/F3/F4/F5: Offset 60h: bit 16 is cleared), the root port will set RSTS.PS, and log the PME Requester ID into RSTS.RID (D28:F0/F1/F2/F3/F4/F5: Offset 60h: bits 15:0). If an interrupt is enabled via RCTL.PIE (D28:F0/F1/F2/F3/F4/F5: Offset 5Ch: bit 3), an interrupt will be generated. This interrupt can be either a pin or an MSI if MSI is enabled via MC.MSIE (D28:F0/F1/F2/F3/F4/F5: Offset 82h: bit 0). See [Section 5.2.2.4](#) for SMI/SCI generation.

If this is a subsequent message received (RSTS.PS is already set), the root port will set RSTS.PP (D28:F0/F1/F2/F3/F4/F5: Offset 60h: bit 17) and log the PME Requester ID from the message in a hidden register. No other action will be taken.

When the first PME event is cleared by software clearing RSTS.PS, the root port will set RSTS.PS, clear RSTS.PP, and move the requester ID from the hidden register into RSTS.RID.

If RCTL.PIE is set, generate an interrupt. If RCTL.PIE is not set, send over to the power management controller so that a GPE can be set. If messages have been logged (RSTS.PS is set), and RCTL.PIE is later written from a 0 to a 1, and interrupt must be generated. This last condition handles the case where the message was received prior to the operating system re-enabling interrupts after resuming from a low power state.



### 5.2.2.4 SMI/SCI Generation

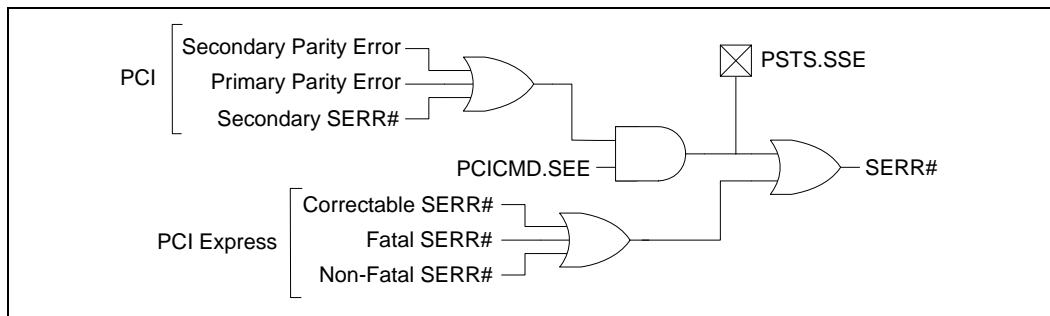
Interrupts for power management events are not supported on legacy operating systems. To support power management on non-PCI Express aware operating systems, PM events can be routed to generate SCI. To generate SCI, MPC.PMCE must be set. When set, a power management event will cause SMSCS.PMCS (D28:F0/F1/F2/F3/F4/F5:Offset DCh:bit 31) to be set.

Additionally, BIOS workarounds for power management can be supported by setting MPC.PMME (D28:F0/F1/F2/F3/F4/F5:Offset D8h:bit 0). When this bit is set, power management events will set SMSCS.PMMS (D28:F0/F1/F2/F3/F4/F5:Offset DCh:bit 0), and SMI # will be generated. This bit will be set regardless of whether interrupts or SCI is enabled. The SMI# may occur concurrently with an interrupt or SCI.

### 5.2.3 SERR# Generation

SERR# may be generated via two paths – through PCI mechanisms involving bits in the PCI header, or through PCI Express mechanisms involving bits in the PCI Express capability structure.

Figure 6. Generation of SERR# to Platform



### 5.2.4 Hot-Plug

Each root port implements a Hot-Plug controller which performs the following:

- Messages to turn on / off / blink LEDs
- Presence and attention button detection
- Interrupt generation

The root port only allows Hot-Plug with modules (e.g., ExpressCard\*). Edge-connector based Hot-Plug is not supported.

#### 5.2.4.1 Presence Detection

When a module is plugged in and power is supplied, the physical layer will detect the presence of the device, and the root port sets SLSTS.PDS (D28:F0/F1/F2/F3/F4/F5:Offset 5Ah:bit 6) and SLSTS.PDC (D28:F0/F1/F2/F3:Offset 6h:bit 3). If SLCTL.PDE (D28:F0/F1/F2/F3F4/F5:Offset 58h:bit 3) and SLCTL.HPE (D28:F0/F1/F2/F3F4/F5:Offset 58h:bit 5) are both set, the root port will also generate an interrupt.

When a module is removed (via the physical layer detection), the root port clears SLSTS.PDS and sets SLSTS.PDC. If SLCTL.PDE and SLCTL.HPE are both set, the root port will also generate an interrupt.

### 5.2.4.2 Message Generation

When system software writes to SLCTL.AIC (D28:F0/F1/F2/F3F4/F5:Offset 58h:bits 7:6) or SLCTL.PIC (D28:F0/F1/F2/F3F4/F5:Offset 58h:bits 9:8), the root port will send a message down the link to change the state of LEDs on the module.

Writes to these fields are non-postable cycles, and the resulting message is a postable cycle. When receiving one of these writes, the root port performs the following:

- Changes the state in the register.
- Generates a completion into the upstream queue
- Formulates a message for the downstream port if the field is written to regardless of if the field changed.
- Generates the message on the downstream port
- When the last message of a command is transmitted, sets SLSTS.CCE (D28:F0/F1/F2/F3F4/F5:Offset 58h:bit 4) to indicate the command has completed. If SLCTL.CCE and SLCTL.HPE (D28:F0/F1/F2/F3F4/F5:Offset 58h:bit 5) are set, the root port generates an interrupt.

The command completed register (SLSTS.CC) applies only to commands issued by software to control the Attention Indicator (SLCTL.AIC), Power Indicator (SLCTL.PIC), or Power Controller (SLCTL.PCC). However, writes to other parts of the Slot Control Register would invariably end up writing to the indicators, power controller fields; Hence, any write to the Slot Control Register is considered a command and if enabled, will result in a command complete interrupt. The only exception to this rule is a write to disable the command complete interrupt which will not result in a command complete interrupt.

A single write to the Slot Control register is considered to be a single command, and hence receives a single command complete, even if the write affects more than one field in the Slot Control Register.

### 5.2.4.3 Attention Button Detection

When an attached device is ejected, an attention button could be pressed by the user. This attention button press will result in a the PCI Express message "Attention\_Button\_Pressed" from the device. Upon receiving this message, the root port will set SLSTS.ABP (D28:F0/F1/F2/F3F4/F5:Offset 5Ah:bit 0).

If SLCTL.ABE (D28:F0/F1/F2/F3F4/F5:Offset 58h:bit 0) and SLCTL.HPE (D28:F0/F1/F2/F3F4/F5:Offset 58h:bit 5) are set, the Hot-Plug controller will also generate an interrupt. The interrupt is generated on an edge-event. For example, if SLSTS.ABP is already set, a new interrupt will not be generated.



#### 5.2.4.4 SMI/SCI Generation

Interrupts for Hot-Plug events are not supported on legacy operating systems. To support Hot-Plug on non-PCI Express aware operating systems, Hot-Plug events can be routed to generate SCI. To generate SCI, MPC.HPCE (D28:F0/F1/F2/F3F4/F5: Offset D8h: bit 30) must be set. When set, enabled Hot-Plug events will cause SMSCS.HPCS (D28:F0/F1/F2/F3F4/F5: Offset DCh: bit 30) to be set.

Additionally, BIOS workarounds for Hot-Plug can be supported by setting MPC.HPME (D28:F0/F1/F2/F3F4/F5: Offset D8h: bit 1). When this bit is set, Hot-Plug events can cause SMI status bits in SMSCS to be set. Supported Hot-Plug events and their corresponding SMSCS bit are:

- Command Completed - SCSCS.HPCCM (D28:F0/F1/F2/F3/F4/F5: Offset DCh: bit 3)
- Presence Detect Changed - SMSCS.HPPDM (D28:F0/F1/F2/F3/F4/F5: Offset DCh: bit 1)
- Attention Button Pressed - SMSCS.HPABM (D28:F0/F1/F2/F3/F4/F5: Offset DCh: bit 2)
- Link Active State Changed - SMSCS.HPLAS (D28:F0/F1/F2/F3/F4/F5: Offset DCh: bit 4)

When any of these bits are set, SMI # will be generated. These bits are set regardless of whether interrupts or SCI is enabled for Hot-Plug events. The SMI# may occur concurrently with an interrupt or SCI.

## 5.3 Gigabit Ethernet Controller (B0:D25:F0)

The ICH8 integrates a Gigabit Ethernet Controller. The integrated GbE controller is compatible with Intel 10/100 PHY (Intel® 82562V Platform LAN Connect device) and GbE PHY (Intel® 82566 Gigabit Platform LAN Connect device). The integrated GbE controller provides two interfaces: LCI for 10/100 operation and GLCI for GbE operation. The GLCI is shared with the ICH8's PCI Express port 6 and can be enabled via a soft strap that is stored in system SPI flash.

The ICH8 integrated GbE controller supports multi speed operation, 10/100/1000 Mb/s. The integrated GbE can operate in full-duplex at all supported speed or half-duplex at 10/100 Mb/s, and adheres with the *IEEE 802.3x Flow Control Specification*.

The controller provides a system interface via a PCI function. A full memory-mapped or I/O-mapped interface is provided to the software, along with DMA mechanisms for high performance data transfer.

The following summarizes the ICH8 integrated GbE controller features:

- Configurable LED operation for customization of LED display.
- IPv4 and IPv6 Checksum Offload support (receive, transmit, and large send)
- 64-bit address master support for system using more than 4 GB of physical memory.
- Configurable receive and transmit data FIFO, programmable in 1 KB increments.
- Intelligent interrupt generation to enhance driver performance
- Compliance with Advanced Configuration and Power Interface and PCI Power Management standards
- ACPI register set and power down functionality supporting D0 & D3 states
- Full wake-up support (ACPI)
- Magic Packet wake-up enable with unique MAC address
- Fragmented UDP checksum off load for package reassembly

### 5.3.1 GbE PCI Bus Interface

The GbE controller has a PCI interface to the host processor and host memory. The following sections detail the transaction on the bus.

#### 5.3.1.1 Transaction Layer

The upper layer of the host architecture is the transaction layer. The transaction layer connects to the device core using an implementation specific protocol. Through this core-to-transaction-layer protocol, the application-specific parts of the device interact with the subsystem and transmit and receive requests to or from the remote agent, respectively.

#### 5.3.1.2 Data Alignment

##### 5.3.1.2.1 4K Boundary

PCI requests must never specify an Address/Length combination that causes a Memory Space access to cross a 4K boundary. It is the HW responsibility to break requests into 4K-aligned requests (if needed). This does not pose any requirement on SW. However, if SW allocates a buffer across a 4K boundary, HW will issue multiple requests for the buffer. SW should consider aligning buffers to 4KB boundary in cases where it improves performance.

The alignment to the 4K boundaries is done in the core. The Transaction layer will not do any alignment according to these boundaries.



#### 5.3.1.2.2 64 Bytes

PCI requests are multiples of 64 bytes and aligned to make better use of memory controller resources. Writes, however, can be on any boundary and can cross a 64 byte alignment boundary

#### 5.3.1.3 Configuration Request Retry Status

The LAN Controller might have a delay in initialization due to NVM read. If the NVM configuration read operation is not completed and the device receives a Configuration Request, the device will respond with a Configuration Request Retry Completion Status to terminate the Request, and thus effectively stall the Configuration Request until such time that the subsystem has completed local initialization and is ready to communicate with the host.

### 5.3.2 Error Events and Error Reporting

#### 5.3.2.1 Data Parity Error

The PCI Host bus does not provide parity protection, but it does forward parity errors from bridges. The LAN Controller recognizes parity errors through the internal bus interface and will set the Parity Error bit in PCI Configuration space. If parity errors are enabled in configuration space, a system error will be indicated on the PCI Host bus to the chipset. The offending cycle with a parity error will be dropped and not processed by the LAN Controller.

#### 5.3.2.2 Completion with Unsuccessful Completion Status

A completion with unsuccessful completion status (any status other than "000") will be dropped and not processed by the LAN Controller. Furthermore, the request that corresponds to the unsuccessful completion will not be retried. When this unsuccessful completion status is received, the System Error bit in the PCI Configuration space will be set. If the system errors are enabled in configuration space, a system error will be indicated on the PCI Host bus to the chipset.

### 5.3.3 Ethernet Interface

The integrated LAN controller provides a complete CSMA/CD function supporting IEEE 802.3 (10Mb/s), 802.3u (100Mb/s) implementations. It also supports the IEEE 802.3z and 802.3ab (1000Mb/s) implementations. The device performs all of the functions required for transmission, reception and collision handling called out in the standards.

The mode used to communicate between the LAN controller and the LAN connect device supports 10/100/1000 Mbps operation, with both half- and full-duplex operation at 10/100 Mbps, and full-duplex operation at 1000 Mbps

#### 5.3.3.1 MAC/LAN Connect Interface

The integrated LAN controller and LAN Connect Device communicate through either the platform LAN connect interface (LCI) or GbE LAN connect interface (GLCI). All controller configuration is performed using device control registers mapped into system memory or I/O space. The LAN Connect Device is configured via the LCI or GbE Lan connect interface.

The integrated MAC supports various modes as summarized in [Table 41](#).



Table 41. LAN Mode Support

Mode	Interface Active	Connections
Legacy 10/100	LCI	82562
Normal 10/100/1000	LCI, GLCI	82566

### 5.3.4 PCI Power Management

The LAN Controller supports the Advanced Configuration and Power Interface (ACPI) specification as well as Advanced Power Management (APM). This allows the host to be awoken (i.e. from Sx to S0) by network-related activity via an internal host wake signal.

The LAN controller contains power management registers for PCI, and supports D0 and D3 states. PCI transactions are only allowed in the D0 state, except for host accesses to the LAN controller's PCI configuration registers.

#### 5.3.4.1 Wake-Up

The LAN Controller supports two types of wakeup mechanisms:

- 1) Advanced Power Management (APM) Wakeup
- 2) ACPI Power Management Wakeup

Both mechanisms use an internal WAKE# signal to wake the system up. This signal is connected to the resume wake logic in the ICH8. The wake-up steps are as follows:

- 1) Host Wake Event occurs (note that packet is not delivered to host)
- 2) PME\_STATUS bit is set
- 3) Internal WAKE# signal asserted by Host LAN function
- 4) System wakes from Sx state to S0 state
- 5) The Host LAN function is transitioned to D0
- 6) The Host clears the PME\_STATUS bit
- 7) Internal WAKE# signal is deasserted by Host LAN function

##### 5.3.4.1.1 Advanced Power Management Wakeup

"Advanced Power Management Wakeup", or "APM Wakeup", was previously known as "Wake on LAN". It is a feature that has existed in the 10/100 Mbps NICs for several generations. The basic premise is to receive a broadcast or unicast packet with an explicit data pattern, and then to assert a signal to wake-up the system. In the earlier generations, this was accomplished by using special signal that ran across a cable to a defined connector on the motherboard. The NIC would assert the signal for approximately 50ms to signal a wakeup. The LAN Controller uses (if configured to) an in-band PM\_PME message for this.

On power-up, the LAN Controller will read the APM Enable bits from the NVM PCI Init Control Word into the APM Enable (APME) bits of the Wakeup Control Register (WUC). These bits control enabling of APM Wakeup.

When APM Wakeup is enabled, the LAN Controller checks all incoming packets for "Magic Packets".





Once the LAN Controller receives a matching magic packet, it will:

- Set the Magic Packet Received bit in the Wake Up Status Register (WUS).
- Set the PME\_Status bit in the Power Management Control / Status Register (PMCSR) and assert the internal WAKE# signal.

"APM Wakeup" is supported in all power states and only disabled if a subsequent NVM read results in the APM Wake Up bit being cleared or the software explicitly writes a 0 to the APM Wake Up (APM) bit of the WUC register.

#### 5.3.4.1.2 ACPI Power Management Wakeup

The LAN Controller supports ACPI Power Management based Wakeups. It can generate system wake-up events from three sources:

- Reception of a "Magic Packet".
- Reception of a Network Wakeup Packet.
- Detection of a link change of state.

Activating ACPI Power Management Wakeup requires the following steps:

- The driver programs the Wake Up Filter Control Register (WUFC) to indicate the packets it wishes to wake up and supplies the necessary data to the Ipv4 Address Table (IP4AT) and the Flexible Filter Mask Table (FFMT), Flexible Filter Length Table (FFLT), and the Flexible Filter Value Table (FFVT). It can also set the Link Status Change Wake Up Enable (LNKC) bit in the Wake Up Filter Control Register (WUFC) to cause wakeup when the link changes state.
- The OS (at configuration time) writes a 1 to the PME\_En bit of the Power Management Control / Status Register (PMCSR.8).

Normally, after enabling wakeup, the OS will write 11b to the lower two bits of the PMCSR to put the LAN Controller into low-power mode.

Once Wakeup is enabled, the LAN Controller monitors incoming packets, first filtering them according to its standard address filtering method, then filtering them with all of the enabled wakeup filters. If a packet passes both the standard address filtering and at least one of the enabled wakeup filters, the LAN Controller will:

- Set the PME\_Status bit in the Power Management Control / Status Register (PMCSR)
- If the PME\_En bit in the Power Management Control / Status Register (PMCSR) is set, assert the internal WAKE# signal.
- Set one or more of the "Received" bits in the Wake Up Status Register (WUS). (More than one bit will be set if a packet matches more than one filter.)

If enabled, a link state change wakeup will cause similar results, setting PME\_Status, asserting the internal WAKE# signal and setting the Link Status Changed (LNKC) bit in the Wake Up Status Register (WUS) when the link goes up or down.

The internal WAKE# signal will remain asserted until the OS either writes a 1 to the PME\_Status bit of the PMCSR register or writes a 0 to the PME\_En bit.

After receiving a wakeup packet, the LAN Controller will ignore any subsequent wakeup packets until the driver clears all of the "Received" bits in the Wake Up Status Register (WUS). It will also ignore link change events until the driver clears the Link Status Changed (LNKC) bit in the Wake Up Status Register (WUS).



### 5.3.5 Configurable LEDs

The LAN Controller supports 3 controllable and configurable LEDs that are driven from the LAN Connect Device. Each of the three LED outputs can be individually configured to select the particular event, state, or activity, which will be indicated on that output. In addition, each LED can be individually configured for output polarity as well as for blinking versus non-blinking (steady-state) indication.

The configuration for LED outputs is specified via the LEDCTL register. Furthermore, the hardware-default configuration for all the LED outputs, can be specified via NVM fields, thereby supporting LED displays configurable to a particular OEM preference.

Each of the 3 LEDs may be configured to use one of a variety of sources for output indication. The MODE bits control the LED source:

- LINK\_100/1000 is asserted when link is established at either 100 or 1000 Mbps.
- LINK\_10/1000 is asserted when link is established at either 10 or 1000 Mbps.
- LINK\_UP is asserted when any speed link is established and maintained.
- ACTIVITY is asserted when link is established and packets are being transmitted or received.
- LINK/ACTIVITY is asserted when link is established AND there is NO transmit or receive activity
- LINK\_10 is asserted when a 10 Mbps link is established and maintained.
- LINK\_100 is asserted when a 100 Mbps link is established and maintained.
- LINK\_1000 is asserted when a 1000 Mbps link is established and maintained.
- FULL\_DUPLEX is asserted when the link is configured for full duplex operation.
- COLLISION is asserted when a collision is observed.
- PAUSED is asserted when the device's transmitter is flow controlled.
- LED\_ON is always asserted; LED\_OFF is always de-asserted.

The IVRT bits allow the LED source to be inverted before being output or observed by the blink-control logic. LED outputs are assumed to normally be connected to the negative side (cathode) of an external LED.

The BLINK bits control whether the LED should be blinked while the LED source is asserted, and the blinking frequency (either 200 ms on and 200 ms off or 83 ms on and 83 ms off). The blink control may be especially useful for ensuring that certain events, such as ACTIVITY indication, cause LED transitions, which are sufficiently visible to a human eye. The same blinking rate is shared by all LEDs.

### 5.3.6 Intel® Auto Connect Battery Saver (Mobile Only)

Intel® Auto Connect Battery Saver (ACBS) is a power saving feature that completely or partially shuts down the Intel® 82566 Gigabit Platform LAN Connect (PLC) device. This power saving mode, if enabled, is entered upon link loss due to LAN cable disconnection in S0. The PLC device will automatically resume power and reestablish its connection when link pulses from a link partner are detected in S0.

The Intel® ACBS feature is controlled by the LAN Driver. The SW driver is responsible for the PLC transitioning into Intel ACBS mode and the ICH8M Gigabit LAN Controller HW is responsible for detecting the presence of a link partner which indicates that the Intel ACBS mode should be terminated.



### 5.3.6.1 Partial and Full Power Down Options

Intel Auto Connect Battery Saver has two power saving implementations: partial or full power down of the PLC device. Both options require an external discrete energy detection circuit and the use of the ICH8M ENERGY\_DETECT signal.

**Partial Power Down:** Upon link loss the LAN controller sends an in-band message to power down the internal 1.8V and 1.0V voltage regulators of the PLC device.

**Full Power Down:** The LAN PHY Power Control feature can be used to signal to an external power supply controller or a FET switch to power down all the externally supplied voltage rails of the PLC device.

#### 5.3.6.1.1 Energy Detect

Energy Detection is essential to Intel ACBS operation. Energy Detection uses an on-board discrete circuit to indicate a link partner is connected to the LAN cable. When in Intel ACBS mode and a link is reestablished the ENERGY\_DETECT signal will indicate to the ICH8M Gigabit LAN Controller (GPIO13 input) to exit Intel ACBS mode and restore power to the PLC device using the LAN PHY power control feature. Refer to Mobile Design Guides for further information on the Energy Detection circuit.

#### 5.3.6.1.2 LAN PHY Power Control

The LAN PHY Power Control function controls the power supplies to the PLC device. The LAN PHY Power Control function can be routed to a power supply controller or FET switch using either the ICH8M GLAN\_DOCK# or SPI\_CS1# signals configured by the appropriate soft straps described in Section 24.2.5. The polarity of the signal associated with the LAN PHY Power Control function can be configured in the NVM, refer to the *Intel® I/O Controller Hub 8 (ICH8) NVM Map and Programming Information Application Note (AP-496)* for details. The LAN PHY power control feature is required to fully power down the PLC device. This feature is also used to restore power to the PLC device when the ENERGY\_DETECT signal is asserted and the PLC device is in Intel ACBS mode.

A platform designer may choose to implement Intel ACBS without the LAN PHY Power Control feature. In such a case, the PLC device will only be able to be partially powered down when the internal voltage regulators are used.

### 5.3.6.2 Intel® ACBS Signal Configurations

Both partial and full power down implementations of Intel ACBS require the use of GPIO13 of the ICH8M as the ENERGY\_DETECT signal. There are no additional ICH8M configuration requirements for partial power down functionality.

For full power down capability two configurations are available for implementation of Intel ACBS:

1. The recommended implementation is to use the GLAN\_DOCK# signal for LAN PHY Power Control functionality.
2. If GLAN\_DOCK# is a required signal, SPI\_CS1# can be configured to support the LAN PHY Power control feature.

Both configurations are set by the use of ICH8M soft straps located in the Flash Descriptor Memory Mapped Configuration Registers. See Section 24.2.5.1. If both GLAN\_DOCK# and SPI\_CS1# are required signals, only Intel ACBS with partial power down functionality can be enabled.

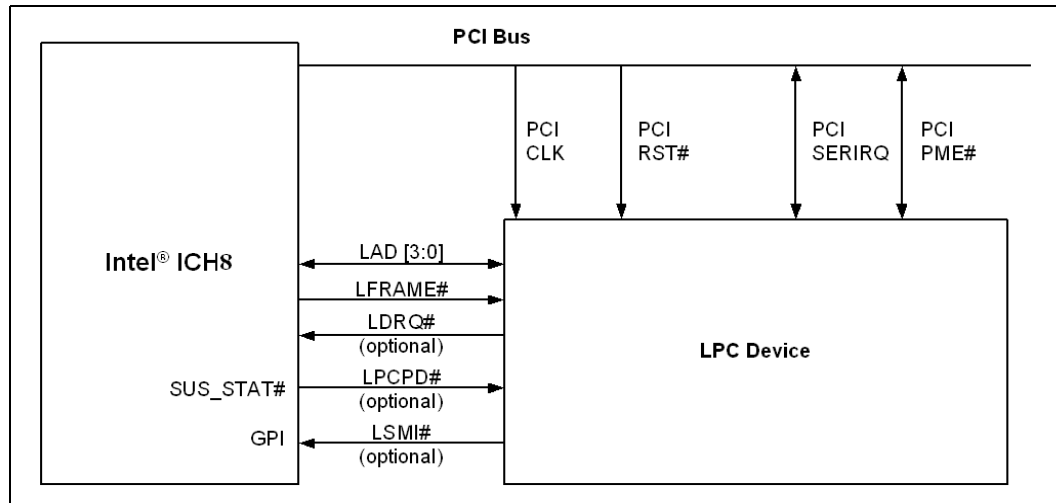
## 5.4 LPC Bridge (w/ System and Management Functions) (D31:F0)

The LPC bridge function of the ICH8 resides in PCI Device 31:Function 0. In addition to the LPC bridge function, D31:F0 contains other functional units including DMA, Interrupt controllers, Timers, Power Management, System Management, GPIO, and RTC. In this chapter, registers and functions associated with other functional units (power management, GPIO, USB, IDE (Mobile only), etc.) are described in their respective sections.

### 5.4.1 LPC Interface

The ICH8 implements an LPC interface as described in the *Low Pin Count Interface Specification*, Revision 1.1. The LPC interface to the ICH8 is shown in Figure 7. Note that the ICH8 implements all of the signals that are shown as optional, but peripherals are not required to do so.

Figure 7. LPC Interface Diagram





### 5.4.1.1 LPC Cycle Types

The ICH8 implements all of the cycle types described in the *Low Pin Count Interface Specification*, Revision 1.0. [Table 42](#) shows the cycle types supported by the ICH8.

**Table 42. LPC Cycle Types Supported**

Cycle Type	Comment
I/O Read	1 byte only. Intel® ICH8 breaks up 16- and 32-bit processor cycles into multiple 8-bit transfers.
I/O Write	1 byte only. ICH8 breaks up 16- and 32-bit processor cycles into multiple 8-bit transfers.
DMA Read	Can be 1, or 2 bytes
DMA Write	Can be 1, or 2 bytes
Bus Master Read	Can be 1, 2, or 4 bytes. (See Note 2 below)
Bus Master Write	Can be 1, 2, or 4 bytes. (See Note 2 below)

**NOTES:**

- For memory cycles below 16 MB that do not target enabled firmware hub ranges, the ICH8 performs standard LPC memory cycles. It only attempts 8-bit transfers. For larger transfers, the ICH8 performs multiple 8-bit transfers. If the cycle is not claimed by any peripheral, it is subsequently aborted, and the ICH8 returns a value of all 1s to the processor. This is done to maintain compatibility with ISA memory cycles where pull-up resistors would keep the bus high if no device responds.
- Bus Master Read or Write cycles must be naturally aligned. For example, a 1-byte transfer can be to any address. However, the 2-byte transfer must be word-aligned (i.e., with an address where A0=0). A dword transfer must be dword-aligned (i.e., with an address where A1 and A0 are both 0).

### 5.4.1.2 Start Field Definition

**Table 43. Start Field Bit Definitions**

Bits[3:0] Encoding	Definition
0000	Start of cycle for a generic target
0010	Grant for bus master 0
0011	Grant for bus master 1
1111	Stop/Abort: End of a cycle for a target.

**NOTE:** All other encodings are RESERVED.



### 5.4.1.3 Cycle Type / Direction (CYCTYPE + DIR)

The ICH8 always drives bit 0 of this field to 0. Peripherals running bus master cycles must also drive bit 0 to 0. [Table 44](#) shows the valid bit encodings.

**Table 44. Cycle Type Bit Definitions**

Bits[3:2]	Bit1	Definition
00	0	I/O Read
00	1	I/O Write
10	0	DMA Read
10	1	DMA Write
11	x	Reserved. If a peripheral performing a bus master cycle generates this value, the Intel® ICH8 aborts the cycle.

### 5.4.1.4 Size

Bits[3:2] are reserved. The ICH8 always drives them to 00. Peripherals running bus master cycles are also supposed to drive 00 for bits 3:2; however, the ICH8 ignores those bits. Bits[1:0] are encoded as listed in [Table 45](#).

**Table 45. Transfer Size Bit Definition**

Bits[1:0]	Size
00	8-bit transfer (1 byte)
01	16-bit transfer (2 bytes)
10	Reserved. The Intel® ICH8 never drives this combination. If a peripheral running a bus master cycle drives this combination, the ICH8 may abort the transfer.
11	32-bit transfer (4 bytes)



### 5.4.1.5 SYNC

Valid values for the SYNC field are shown in Table 46.

**Table 46. SYNC Bit Definition**

Bits[3:0]	Indication
0000	<b>Ready:</b> SYNC achieved with no error. For DMA transfers, this also indicates DMA request deassertion and no more transfers desired for that channel.
0101	<b>Short Wait:</b> Part indicating wait-states. For bus master cycles, the Intel® ICH8 does not use this encoding. Instead, the ICH8 uses the Long Wait encoding (see next encoding below).
0110	<b>Long Wait:</b> Part indicating wait-states, and many wait-states will be added. This encoding driven by the ICH8 for bus master cycles, rather than the Short Wait (0101).
1001	<b>Ready More (Used only by peripheral for DMA cycle):</b> SYNC achieved with no error and more DMA transfers desired to continue after this transfer. This value is valid only on DMA transfers and is not allowed for any other type of cycle.
1010	<b>Error:</b> Sync achieved with error. This is generally used to replace the SERR# or IOCHK# signal on the PCI/ISA bus. It indicates that the data is to be transferred, but there is a serious error in this transfer. For DMA transfers, this not only indicates an error, but also indicates DMA request deassertion and no more transfers desired for that channel.

**NOTES:**

1. All other combinations are RESERVED.
2. If the LPC controller receives any SYNC returned from the device other than short (0101), long wait (0110), or ready (0000) when running a FWH cycle, indeterminate results may occur. A FWH device is not allowed to assert an Error SYNC.

### 5.4.1.6 SYNC Time-Out

There are several error cases that can occur on the LPC interface. The ICH8 responds as defined in Section 4.2.1.9 of the *Low Pin Count Interface Specification*, Revision 1.1 to the stimuli described therein. There may be other peripheral failure conditions; however, these are not handled by the ICH8.

### 5.4.1.7 SYNC Error Indication

The ICH8 responds as defined in Section 4.2.1.10 of the *Low Pin Count Interface Specification*, Revision 1.1.

Upon recognizing the SYNC field indicating an error, the ICH8 treats this as an SERR by reporting this into the Device 31 Error Reporting Logic.

### 5.4.1.8 LFRAME# Usage

The ICH8 follows the usage of LFRAME# as defined in the *Low Pin Count Interface Specification*, Revision 1.1.

The ICH8 performs an abort for the following cases (possible failure cases):

- ICH8 starts a Memory, I/O, or DMA cycle, but no device drives a valid SYNC after four consecutive clocks.
- ICH8 starts a Memory, I/O, or DMA cycle, and the peripheral drives an invalid SYNC pattern.
- A peripheral drives an invalid address when performing bus master cycles.
- A peripheral drives an invalid value.



#### 5.4.1.9 I/O Cycles

For I/O cycles targeting registers specified in the ICH8's decode ranges, the ICH8 performs I/O cycles as defined in the *Low Pin Count Interface Specification*, Revision 1.1. These are 8-bit transfers. If the processor attempts a 16-bit or 32-bit transfer, the ICH8 breaks the cycle up into multiple 8-bit transfers to consecutive I/O addresses.

**Note:** If the cycle is not claimed by any peripheral (and subsequently aborted), the ICH8 returns a value of all 1s (FFh) to the processor. This is to maintain compatibility with ISA I/O cycles where pull-up resistors would keep the bus high if no device responds.

#### 5.4.1.10 Bus Master Cycles

The ICH8 supports Bus Master cycles and requests (using LDRQ#) as defined in the *Low Pin Count Interface Specification*, Revision 1.1. The ICH8 has two LDRQ# inputs, and thus supports two separate bus master devices. It uses the associated START fields for Bus Master 0 (0010b) or Bus Master 1 (0011b).

**Note:** The ICH8 does not support LPC Bus Masters performing I/O cycles. LPC Bus Masters should only perform memory read or memory write cycles.

#### 5.4.1.11 LPC Power Management

##### CLKRUN# Protocol (Mobile Only)

The CLKRUN# protocol is same as the *PCI Local Bus Specification*. Stopping the PCI clock stops the LPC clock.

##### LPCPD# Protocol

Same timings as for SUS\_STAT#. Upon driving SUS\_STAT# low, LPC peripherals drive LDRQ# low or tri-state it. ICH8 shuts off the LDRQ# input buffers. After driving SUS\_STAT# active, the ICH8 drives LFRAME# low, and tri-states (or drive low) LAD[3:0].

**Note:** The *Low Pin Count Interface Specification*, Revision 1.1 defines the LPCPD# protocol where there is at least 30  $\mu$ s from LPCPD# assertion to LRST# assertion. This specification explicitly states that this protocol only applies to entry/exit of low power states which does not include asynchronous reset events. The ICH8 asserts both SUS\_STAT# (connects to LPCPD#) and PLTRST# (connects to LRST#) at the same time when the core logic is reset (via CF9h, PWROK, or SYS\_RESET#, etc.). This is not inconsistent with the LPC LPCPD# protocol.

#### 5.4.1.12 Configuration and Intel® ICH8 Implications

##### LPC I/F Decoders

To allow the I/O cycles and memory mapped cycles to go to the LPC interface, the ICH8 includes several decoders. During configuration, the ICH8 must be programmed with the same decode ranges as the peripheral. The decoders are programmed via the Device 31:Function 0 configuration space.

**Note:** The ICH8 cannot accept PCI write cycles from PCI-to-PCI bridges or devices with similar characteristics (specifically those with a "Retry Read" feature which is enabled) to an LPC device if there is an outstanding LPC read cycle towards the same PCI device or bridge. These cycles are not part of normal system operation, but may be encountered as part of platform validation testing using custom test fixtures.





## Bus Master Device Mapping and START Fields

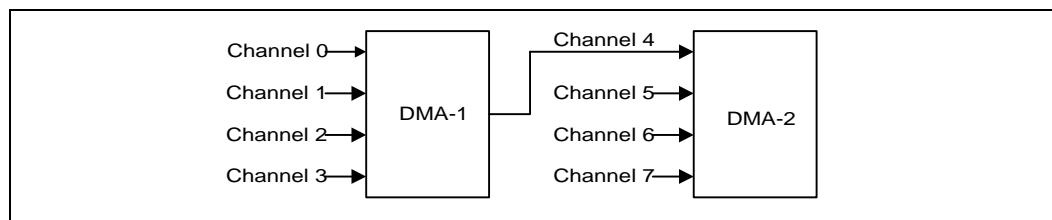
Bus Masters must have a unique START field. In the case of the ICH8 that supports two LPC bus masters, it drives 0010 for the START field for grants to bus master #0 (requested via LDRQ0#) and 0011 for grants to bus master #1 (requested via LDRQ1#.). Thus, no registers are needed to configure the START fields for a particular bus master.

## 5.5 DMA Operation (D31:F0)

The ICH8 supports LPC DMA using the ICH8's DMA controller. The DMA controller has registers that are fixed in the lower 64 KB of I/O space. The DMA controller is configured using registers in the PCI configuration space. These registers allow configuration of the channels for use by LPC DMA.

The DMA circuitry incorporates the functionality of two 82C37 DMA controllers with seven independently programmable channels (Figure 8). DMA controller 1 (DMA-1) corresponds to DMA channels 0–3 and DMA controller 2 (DMA-2) corresponds to channels 5–7. DMA channel 4 is used to cascade the two controllers and defaults to cascade mode in the DMA Channel Mode (DCM) Register. Channel 4 is not available for any other purpose. In addition to accepting requests from DMA slaves, the DMA controller also responds to requests that software initiates. Software may initiate a DMA service request by setting any bit in the DMA Channel Request Register to a 1.

Figure 8. Intel® ICH8 DMA Controller



Each DMA channel is hardwired to the compatible settings for DMA device size: channels [3:0] are hardwired to 8-bit, count-by-bytes transfers, and channels [7:5] are hardwired to 16-bit, count-by-words (address shifted) transfers.

ICH8 provides 24-bit addressing in compliance with the ISA-Compatible specification. Each channel includes a 16-bit ISA-Compatible Current Register which holds the 16 least-significant bits of the 24-bit address, an ISA-Compatible Page Register which contains the eight next most significant bits of address.

The DMA controller also features refresh address generation, and auto-initialization following a DMA termination.

### 5.5.1 Channel Priority

For priority resolution, the DMA consists of two logical channel groups: channels 0–3 and channels 4–7. Each group may be in either fixed or rotate mode, as determined by the DMA Command Register.

DMA I/O slaves normally assert their DREQ line to arbitrate for DMA service. However, a software request for DMA service can be presented through each channel's DMA Request Register. A software request is subject to the same prioritization as any hardware request. See the detailed register description for Request Register programming information in Section 9.2.



### 5.5.1.1 Fixed Priority

The initial fixed priority structure is as follows:

High priority	Low priority
0, 1, 2, 3	5, 6, 7

The fixed priority ordering is 0, 1, 2, 3, 5, 6, and 7. In this scheme, channel 0 has the highest priority, and channel 7 has the lowest priority. Channels [3:0] of DMA-1 assume the priority position of channel 4 in DMA-2, thus taking priority over channels 5, 6, and 7.

### 5.5.1.2 Rotating Priority

Rotation allows for “fairness” in priority resolution. The priority chain rotates so that the last channel serviced is assigned the lowest priority in the channel group (0–3, 5–7).

Channels 0–3 rotate as a group of 4. They are always placed between channel 5 and channel 7 in the priority list.

Channel 5–7 rotate as part of a group of 4. That is, channels (5–7) form the first three positions in the rotation, while channel group (0–3) comprises the fourth position in the arbitration.

## 5.5.2 Address Compatibility Mode

When the DMA is operating, the addresses do not increment or decrement through the High and Low Page Registers. Therefore, if a 24-bit address is 01FFFFh and increments, the next address is 010000h, not 020000h. Similarly, if a 24-bit address is 020000h and decrements, the next address is 02FFFFh, not 01FFFFh. However, when the DMA is operating in 16-bit mode, the addresses still do not increment or decrement through the High and Low Page Registers but the page boundary is now 128 K. Therefore, if a 24-bit address is 01FFFEh and increments, the next address is 000000h, not 010000h. Similarly, if a 24-bit address is 020000h and decrements, the next address is 03FFFEh, not 02FFFEh. This is compatible with the 82C37 and Page Register implementation used in the PC-AT. This mode is set after CPURST is valid.



### 5.5.3 Summary of DMA Transfer Sizes

Table 47 lists each of the DMA device transfer sizes. The column labeled “Current Byte/Word Count Register” indicates that the register contents represents either the number of bytes to transfer or the number of 16-bit words to transfer. The column labeled “Current Address Increment/Decrement” indicates the number added to or taken from the Current Address register after each DMA transfer cycle. The DMA Channel Mode Register determines if the Current Address Register will be incremented or decremented.

#### 5.5.3.1 Address Shifting When Programmed for 16-Bit I/O Count by Words

Table 47. DMA Transfer Size

DMA Device Data Size And Word Count	Current Byte/Word Count Register	Current Address Increment/Decrement
8-Bit I/O, Count By Bytes	Bytes	1
16-Bit I/O, Count By Words (Address Shifted)	Words	1

The ICH8 maintains compatibility with the implementation of the DMA in the PC AT that used the 82C37. The DMA shifts the addresses for transfers to/from a 16-bit device count-by-words.

**Note:** The least significant bit of the Low Page Register is dropped in 16-bit shifted mode. When programming the Current Address Register (when the DMA channel is in this mode), the Current Address must be programmed to an even address with the address value shifted right by one bit.

The address shifting is shown in Table 48.

Table 48. Address Shifting in 16-Bit I/O DMA Transfers

Output Address	8-Bit I/O Programmed Address (Ch 0–3)	16-Bit I/O Programmed Address (Ch 5–7) (Shifted)
A0	A0	0
A[16:1] A[23:17]	A[16:1] A[23:17]	A[15:0] A[23:17]

**NOTE:** The least significant bit of the Page Register is dropped in 16-bit shifted mode.

### 5.5.4 Autoinitialize

By programming a bit in the DMA Channel Mode Register, a channel may be set up as an autoinitialize channel. When a channel undergoes autoinitialization, the original values of the Current Page, Current Address and Current Byte/Word Count Registers are automatically restored from the Base Page, Address, and Byte/Word Count Registers of that channel following TC. The Base Registers are loaded simultaneously with the Current Registers by the microprocessor when the DMA channel is programmed and remain unchanged throughout the DMA service. The mask bit is not set when the channel is in autoinitialize. Following autoinitialize, the channel is ready to perform another DMA service, without processor intervention, as soon as a valid DREQ is detected.

### 5.5.5 Software Commands

There are three additional special software commands that the DMA controller can execute. The three software commands are:

- Clear Byte Pointer Flip-Flop
- Master Clear
- Clear Mask Register

They do not depend on any specific bit pattern on the data bus.

## 5.6 LPC DMA

DMA on LPC is handled through the use of the LDRQ# lines from peripherals and special encodings on LAD[3:0] from the host. Single, Demand, Verify, and Increment modes are supported on the LPC interface. Channels 0–3 are 8 bit channels. Channels 5–7 are 16-bit channels.

Channel 4 is reserved as a generic bus master request.

### 5.6.1 Asserting DMA Requests

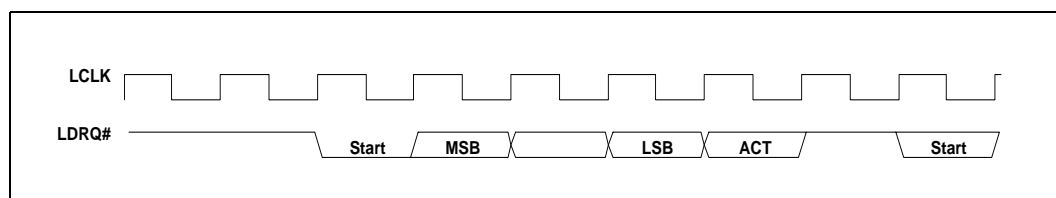
Peripherals that need DMA service encode their requested channel number on the LDRQ# signal. To simplify the protocol, each peripheral on the LPC I/F has its own dedicated LDRQ# signal (they may not be shared between two separate peripherals). The ICH8 has two LDRQ# inputs, allowing at least two devices to support DMA or bus mastering.

LDRQ# is synchronous with LCLK (PCI clock). As shown in Figure 9, the peripheral uses the following serial encoding sequence:

- Peripheral starts the sequence by asserting LDRQ# low (start bit). LDRQ# is high during idle conditions.
- The next three bits contain the encoded DMA channel number (MSB first).
- The next bit (ACT) indicates whether the request for the indicated DMA channel is active or inactive. The ACT bit is 1 (high) to indicate if it is active and 0 (low) if it is inactive. The case where ACT is low is rare, and is only used to indicate that a previous request for that channel is being abandoned.
- After the active/inactive indication, the LDRQ# signal must go high for at least 1 clock. After that one clock, LDRQ# signal can be brought low to the next encoding sequence.

If another DMA channel also needs to request a transfer, another sequence can be sent on LDRQ#. For example, if an encoded request is sent for channel 2, and then channel 3 needs a transfer before the cycle for channel 2 is run on the interface, the peripheral can send the encoded request for channel 3. This allows multiple DMA agents behind an I/O device to request use of the LPC interface, and the I/O device does not need to self-arbitrate before sending the message.

Figure 9. DMA Request Assertion through LDRQ#





## 5.6.2 Abandoning DMA Requests

DMA Requests can be deasserted in two fashions: on error conditions by sending an LDRQ# message with the 'ACT' bit set to 0, or normally through a SYNC field during the DMA transfer. This section describes boundary conditions where the DMA request needs to be removed prior to a data transfer.

There may be some special cases where the peripheral desires to abandon a DMA transfer. The most likely case of this occurring is due to a floppy disk controller which has overrun or underrun its FIFO, or software stopping a device prematurely.

In these cases, the peripheral wishes to stop further DMA activity. It may do so by sending an LDRQ# message with the ACT bit as 0. However, since the DMA request was seen by the ICH8, there is no assurance that the cycle has not been granted and will shortly run on LPC. Therefore, peripherals must take into account that a DMA cycle may still occur. The peripheral can choose not to respond to this cycle, in which case the host will abort it, or it can choose to complete the cycle normally with any random data.

This method of DMA deassertion should be prevented whenever possible, to limit boundary conditions both on the ICH8 and the peripheral.

## 5.6.3 General Flow of DMA Transfers

Arbitration for DMA channels is performed through the 8237 within the host. Once the host has won arbitration on behalf of a DMA channel assigned to LPC, it asserts LFRAME# on the LPC I/F and begins the DMA transfer. The general flow for a basic DMA transfer is as follows:

1. ICH8 starts transfer by asserting 0000b on LAD[3:0] with LFRAME# asserted.
2. ICH8 asserts 'cycle type' of DMA, direction based on DMA transfer direction.
3. ICH8 asserts channel number and, if applicable, terminal count.
4. ICH8 indicates the size of the transfer: 8 or 16 bits.
5. If a DMA read...
  - The ICH8 drives the first 8 bits of data and turns the bus around.
  - The peripheral acknowledges the data with a valid SYNC.
  - If a 16-bit transfer, the process is repeated for the next 8 bits.
6. If a DMA write...
  - The ICH8 turns the bus around and waits for data.
  - The peripheral indicates data ready through SYNC and transfers the first byte.
  - If a 16-bit transfer, the peripheral indicates data ready and transfers the next byte.
7. The peripheral turns around the bus.

## 5.6.4 Terminal Count

Terminal count is communicated through LAD[3] on the same clock that DMA channel is communicated on LAD[2:0]. This field is the CHANNEL field. Terminal count indicates the last byte of transfer, based upon the size of the transfer.

For example, on an 8-bit transfer size (SIZE field is 00b), if the TC bit is set, then this is the last byte. On a 16-bit transfer (SIZE field is 01b), if the TC bit is set, then the second byte is the last byte. The peripheral, therefore, must internalize the TC bit when the CHANNEL field is communicated, and only signal TC when the last byte of that transfer size has been transferred.

### 5.6.5 Verify Mode

Verify mode is supported on the LPC interface. A verify transfer to the peripheral is similar to a DMA write, where the peripheral is transferring data to main memory. The indication from the host is the same as a DMA write, so the peripheral will be driving data onto the LPC interface. However, the host will not transfer this data into main memory.

### 5.6.6 DMA Request Deassertion

An end of transfer is communicated to the ICH8 through a special SYNC field transmitted by the peripheral. An LPC device must not attempt to signal the end of a transfer by deasserting LDREQ#. If a DMA transfer is several bytes (e.g., a transfer from a demand mode device) the ICH8 needs to know when to deassert the DMA request based on the data currently being transferred.

The DMA agent uses a SYNC encoding on each byte of data being transferred, which indicates to the ICH8 whether this is the last byte of transfer or if more bytes are requested. To indicate the last byte of transfer, the peripheral uses a SYNC value of 0000b (ready with no error), or 1010b (ready with error). These encodings tell the ICH8 that this is the last piece of data transferred on a DMA read (ICH8 to peripheral), or the byte that follows is the last piece of data transferred on a DMA write (peripheral to ICH8).

When the ICH8 sees one of these two encodings, it ends the DMA transfer after this byte and deasserts the DMA request to the 8237. Therefore, if the ICH8 indicated a 16-bit transfer, the peripheral can end the transfer after one byte by indicating a SYNC value of 0000b or 1010b. The ICH8 does not attempt to transfer the second byte, and deasserts the DMA request internally.

If the peripheral indicates a 0000b or 1010b SYNC pattern on the last byte of the indicated size, then the ICH8 only deasserts the DMA request to the 8237 since it does not need to end the transfer.

If the peripheral wishes to keep the DMA request active, then it uses a SYNC value of 1001b (ready plus more data). This tells the 8237 that more data bytes are requested after the current byte has been transferred, so the ICH8 keeps the DMA request active to the 8237. Therefore, on an 8-bit transfer size, if the peripheral indicates a SYNC value of 1001b to the ICH8, the data will be transferred and the DMA request will remain active to the 8237. At a later time, the ICH8 will then come back with another START-CYCTYPE-CHANNEL-SIZE etc. combination to initiate another transfer to the peripheral.

The peripheral must not assume that the next START indication from the ICH8 is another grant to the peripheral if it had indicated a SYNC value of 1001b. On a single mode DMA device, the 8237 will re-arbitrate after every transfer. Only demand mode DMA devices can be assured that they will receive the next START indication from the ICH8.

**Note:** Indicating a 0000b or 1010b encoding on the SYNC field of an odd byte of a 16-bit channel (first byte of a 16-bit transfer) is an error condition.

**Note:** The host stops the transfer on the LPC bus as indicated, fills the upper byte with random data on DMA writes (peripheral to memory), and indicates to the 8237 that the DMA transfer occurred, incrementing the 8237's address and decrementing its byte count.



### 5.6.7 SYNC Field / LDRQ# Rules

Since DMA transfers on LPC are requested through an LDRQ# assertion message, and are ended through a SYNC field during the DMA transfer, the peripheral must obey the following rule when initiating back-to-back transfers from a DMA channel.

The peripheral must not assert another message for eight LCLKs after a deassertion is indicated through the SYNC field. This is needed to allow the 8237, that typically runs off a much slower internal clock, to see a message deasserted before it is re-asserted so that it can arbitrate to the next agent.

Under default operation, the host only performs 8-bit transfers on 8-bit channels and 16-bit transfers on 16-bit channels.

The method by which this communication between host and peripheral through system BIOS is performed is beyond the scope of this specification. Since the LPC host and LPC peripheral are motherboard devices, no “plug-n-play” registry is required.

The peripheral must not assume that the host is able to perform transfer sizes that are larger than the size allowed for the DMA channel, and be willing to accept a SIZE field that is smaller than what it may currently have buffered.

To that end, it is recommended that future devices that may appear on the LPC bus, that require higher bandwidth than 8-bit or 16-bit DMA allow, do so with a bus mastering interface and not rely on the 8237.

## 5.7 8254 Timers (D31:F0)

The ICH8 contains three counters that have fixed uses. All registers and functions associated with the 8254 timers are in the core well. The 8254 unit is clocked by a 14.31818 MHz clock.

### Counter 0, System Timer

This counter functions as the system timer by controlling the state of IRQ0 and is typically programmed for Mode 3 operation. The counter produces a square wave with a period equal to the product of the counter period (838 ns) and the initial count value. The counter loads the initial count value 1 counter period after software writes the count value to the counter I/O address. The counter initially asserts IRQ0 and decrements the count value by two each counter period. The counter negates IRQ0 when the count value reaches 0. It then reloads the initial count value and again decrements the initial count value by two each counter period. The counter then asserts IRQ0 when the count value reaches 0, reloads the initial count value, and repeats the cycle, alternately asserting and negating IRQ0.

### Counter 1, Refresh Request Signal

This counter provides the refresh request signal and is typically programmed for Mode 2 operation and only impacts the period of the REF\_TOGGLE bit in Port 61. The initial count value is loaded one counter period after being written to the counter I/O address. The REF\_TOGGLE bit will have a square wave behavior (alternate between 0 and 1) and will toggle at a rate based on the value in the counter. Programming the counter to anything other than Mode 2 will result in undefined behavior for the REF\_TOGGLE bit.

### Counter 2, Speaker Tone

This counter provides the speaker tone and is typically programmed for Mode 3 operation. The counter provides a speaker frequency equal to the counter clock frequency (1.193 MHz) divided by the initial count value. The speaker must be enabled by a write to port 061h (see NMI Status and Control ports).



### 5.7.1 Timer Programming

The counter/timers are programmed in the following fashion:

1. Write a control word to select a counter.
2. Write an initial count for that counter.
3. Load the least and/or most significant bytes (as required by Control Word bits 5, 4) of the 16-bit counter.
4. Repeat with other counters.

Only two conventions need to be observed when programming the counters. First, for each counter, the control word must be written before the initial count is written. Second, the initial count must follow the count format specified in the control word (least significant byte only, most significant byte only, or least significant byte and then most significant byte).

A new initial count may be written to a counter at any time without affecting the counter's programmed mode. Counting is affected as described in the mode definitions. The new count must follow the programmed count format.

If a counter is programmed to read/write two-byte counts, the following precaution applies: A program must not transfer control between writing the first and second byte to another routine which also writes into that same counter. Otherwise, the counter will be loaded with an incorrect count.

The Control Word Register at port 43h controls the operation of all three counters. Several commands are available:

- **Control Word Command.** Specifies which counter to read or write, the operating mode, and the count format (binary or BCD).
- **Counter Latch Command.** Latches the current count so that it can be read by the system. The countdown process continues.
- **Read Back Command.** Reads the count value, programmed mode, the current state of the OUT pins, and the state of the Null Count Flag of the selected counter.

Table 49 lists the six operating modes for the interval counters.





Table 49. Counter Operating Modes

Mode	Function	Description
0	Out signal on end of count (=0)	Output is 0. When count goes to 0, output goes to 1 and stays at 1 until counter is reprogrammed.
1	Hardware retriggerable one-shot	Output is 0. When count goes to 0, output goes to 1 for one clock time.
2	Rate generator (divide by n counter)	Output is 1. Output goes to 0 for one clock time, then back to 1 and counter is reloaded.
3	Square wave output	Output is 1. Output goes to 0 when counter rolls over, and counter is reloaded. Output goes to 1 when counter rolls over, and counter is reloaded, etc.
4	Software triggered strobe	Output is 1. Output goes to 0 when count expires for one clock time.
5	Hardware triggered strobe	Output is 1. Output goes to 0 when count expires for one clock time.

## 5.7.2 Reading from the Interval Timer

It is often desirable to read the value of a counter without disturbing the count in progress. There are three methods for reading the counters: a simple read operation, counter Latch command, and the Read-Back command. Each is explained below.

With the simple read and counter latch command methods, the count must be read according to the programmed format; specifically, if the counter is programmed for two byte counts, two bytes must be read. The two bytes do not have to be read one right after the other. Read, write, or programming operations for other counters may be inserted between them.

### 5.7.2.1 Simple Read

The first method is to perform a simple read operation. The counter is selected through port 40h (counter 0), 41h (counter 1), or 42h (counter 2).

**Note:** Performing a direct read from the counter does not return a determinate value, because the counting process is asynchronous to read operations. However, in the case of counter 2, the count can be stopped by writing to the GATE bit in port 61h.

### 5.7.2.2 Counter Latch Command

The Counter Latch command, written to port 43h, latches the count of a specific counter at the time the command is received. This command is used to ensure that the count read from the counter is accurate, particularly when reading a two-byte count. The count value is then read from each counter's Count register as was programmed by the Control register.

The count is held in the latch until it is read or the counter is reprogrammed. The count is then unlatched. This allows reading the contents of the counters on the fly without affecting counting in progress. Multiple Counter Latch Commands may be used to latch more than one counter. Counter Latch commands do not affect the programmed mode of the counter in any way.



If a Counter is latched and then, some time later, latched again before the count is read, the second Counter Latch command is ignored. The count read is the count at the time the first Counter Latch command was issued.

### 5.7.2.3 Read Back Command

The Read Back command, written to port 43h, latches the count value, programmed mode, and current states of the OUT pin and Null Count flag of the selected counter or counters. The value of the counter and its status may then be read by I/O access to the counter address.

The Read Back command may be used to latch multiple counter outputs at one time. This single command is functionally equivalent to several counter latch commands, one for each counter latched. Each counter's latched count is held until it is read or reprogrammed. Once read, a counter is unlatched. The other counters remain latched until they are read. If multiple count Read Back commands are issued to the same counter without reading the count, all but the first are ignored.

The Read Back command may additionally be used to latch status information of selected counters. The status of a counter is accessed by a read from that counter's I/O port address. If multiple counter status latch operations are performed without reading the status, all but the first are ignored.

Both count and status of the selected counters may be latched simultaneously. This is functionally the same as issuing two consecutive, separate Read Back commands. If multiple count and/or status Read Back commands are issued to the same counters without any intervening reads, all but the first are ignored.

If both count and status of a counter are latched, the first read operation from that counter returns the latched status, regardless of which was latched first. The next one or two reads, depending on whether the counter is programmed for one or two type counts, returns the latched count. Subsequent reads return unlatched count.



## 5.8 8259 Interrupt Controllers (PIC) (D31:F0)

The ICH8 incorporates the functionality of two 8259 interrupt controllers that provide system interrupts for the ISA compatible interrupts. These interrupts are: system timer, keyboard controller, serial ports, parallel ports, floppy disk, IDE (Mobile only), mouse, and DMA channels. In addition, this interrupt controller can support the PCI based interrupts, by mapping the PCI interrupt onto the compatible ISA interrupt line. Each 8259 core supports eight interrupts, numbered 0–7. Table 50 shows how the cores are connected.

**Table 50. Interrupt Controller Core Connections**

8259	8259 Input	Typical Interrupt Source	Connected Pin / Function
Master	0	Internal	Internal Timer / Counter 0 output / HPET #0
	1	Keyboard	IRQ1 via SERIRQ
	2	Internal	Slave controller INTR output
	3	Serial Port A	IRQ3 via SERIRQ, PIRQ#
	4	Serial Port B	IRQ4 via SERIRQ, PIRQ#
	5	Parallel Port / Generic	IRQ5 via SERIRQ, PIRQ#
	6	Floppy Disk	IRQ6 via SERIRQ, PIRQ#
	7	Parallel Port / Generic	IRQ7 via SERIRQ, PIRQ#
Slave	0	Internal Real Time Clock	Internal RTC / HPET #1
	1	Generic	IRQ9 via SERIRQ, SCI, TCO, or PIRQ#
	2	Generic	IRQ10 via SERIRQ, SCI, TCO, or PIRQ#
	3	Generic	IRQ11 via SERIRQ, SCI, TCO, or PIRQ#
	4	PS/2 Mouse	IRQ12 via SERIRQ, SCI, TCO, or PIRQ#
	5	Internal	State Machine output based on processor FERR# assertion. May optionally be used for SCI or TCO interrupt if FERR# not needed.
	6	SATA, IDE cable (Mobile Only)	SATA Primary (legacy mode), or SERIRQ, or PIRQ#. Mobile Only: IDEIRQ (legacy mode, non-combined or combined mapped as primary).
	7	SATA, IDE cable (Mobile Only)	SATA Secondary (legacy mode), or SERIRQ, or PIRQ#. Mobile Only: IDEIRQ (legacy mode — combined, mapped as secondary).

The ICH8 cascades the slave controller onto the master controller through master controller interrupt input 2. This means there are only 15 possible interrupts for the ICH8 PIC.

Interrupts can individually be programmed to be edge or level, except for IRQ0, IRQ2, IRQ8#, and IRQ13.

**Note:** Active-low interrupt sources (e.g., the PIRQ#s) are inverted inside the ICH8. In the following descriptions of the 8259s, the interrupt levels are in reference to the signals at the internal interface of the 8259s, after the required inversions have occurred. Therefore, the term “high” indicates “active,” which means “low” on an originating PIRQ#.

## 5.8.1 Interrupt Handling

### 5.8.1.1 Generating Interrupts

The PIC interrupt sequence involves three bits, from the IRR, ISR, and IMR, for each interrupt level. These bits are used to determine the interrupt vector returned, and status of any other pending interrupts. Table 51 defines the IRR, ISR, and IMR.

Table 51. Interrupt Status Registers

Bit	Description
IRR	<b>Interrupt Request Register.</b> This bit is set on a low to high transition of the interrupt line in edge mode, and by an active high level in level mode. This bit is set whether or not the interrupt is masked. However, a masked interrupt will not generate INTR.
ISR	<b>Interrupt Service Register.</b> This bit is set, and the corresponding IRR bit cleared, when an interrupt acknowledge cycle is seen, and the vector returned is for that interrupt.
IMR	<b>Interrupt Mask Register.</b> This bit determines whether an interrupt is masked. Masked interrupts will not generate INTR.

### 5.8.1.2 Acknowledging Interrupts

The processor generates an interrupt acknowledge cycle that is translated by the host bridge into a PCI Interrupt Acknowledge Cycle to the ICH8. The PIC translates this command into two internal INTA# pulses expected by the 8259 cores. The PIC uses the first internal INTA# pulse to freeze the state of the interrupts for priority resolution. On the second INTA# pulse, the master or slave sends the interrupt vector to the processor with the acknowledged interrupt code. This code is based upon bits [7:3] of the corresponding ICW2 register, combined with three bits representing the interrupt within that controller.

Table 52. Content of Interrupt Vector Byte

Master, Slave Interrupt	Bits [7:3]	Bits [2:0]
IRQ7,15	ICW2[7:3]	111
IRQ6,14		110
IRQ5,13		101
IRQ4,12		100
IRQ3,11		011
IRQ2,10		010
IRQ1,9		001
IRQ0,8		000



### 5.8.1.3 Hardware/Software Interrupt Sequence

1. One or more of the Interrupt Request lines (IRQ) are raised high in edge mode, or seen high in level mode, setting the corresponding IRR bit.
2. The PIC sends INTR active to the processor if an asserted interrupt is not masked.
3. The processor acknowledges the INTR and responds with an interrupt acknowledge cycle. The cycle is translated into a PCI interrupt acknowledge cycle by the host bridge. This command is broadcast over PCI by the ICH8.
4. Upon observing its own interrupt acknowledge cycle on PCI, the ICH8 converts it into the two cycles that the internal 8259 pair can respond to. Each cycle appears as an interrupt acknowledge pulse on the internal INTA# pin of the cascaded interrupt controllers.
5. Upon receiving the first internally generated INTA# pulse, the highest priority ISR bit is set and the corresponding IRR bit is reset. On the trailing edge of the first pulse, a slave identification code is broadcast by the master to the slave on a private, internal three bit wide bus. The slave controller uses these bits to determine if it must respond with an interrupt vector during the second INTA# pulse.
6. Upon receiving the second internally generated INTA# pulse, the PIC returns the interrupt vector. If no interrupt request is present because the request was too short in duration, the PIC returns vector 7 from the master controller.
7. This completes the interrupt cycle. In AEOI mode the ISR bit is reset at the end of the second INTA# pulse. Otherwise, the ISR bit remains set until an appropriate EOI command is issued at the end of the interrupt subroutine.

## 5.8.2 Initialization Command Words (ICWx)

Before operation can begin, each 8259 must be initialized. In the ICH8, this is a four byte sequence. The four initialization command words are referred to by their acronyms: ICW1, ICW2, ICW3, and ICW4.

The base address for each 8259 initialization command word is a fixed location in the I/O memory space: 20h for the master controller, and A0h for the slave controller.

### 5.8.2.1 ICW1

An I/O write to the master or slave controller base address with data bit 4 equal to 1 is interpreted as a write to ICW1. Upon sensing this write, the ICH8 PIC expects three more byte writes to 21h for the master controller, or A1h for the slave controller, to complete the ICW sequence.

A write to ICW1 starts the initialization sequence during which the following automatically occur:

1. Following initialization, an interrupt request (IRQ) input must make a low-to-high transition to generate an interrupt.
2. The Interrupt Mask Register is cleared.
3. IRQ7 input is assigned priority 7.
4. The slave mode address is set to 7.
5. Special mask mode is cleared and Status Read is set to IRR.



#### 5.8.2.2 ICW2

The second write in the sequence (ICW2) is programmed to provide bits [7:3] of the interrupt vector that will be released during an interrupt acknowledge. A different base is selected for each interrupt controller.

#### 5.8.2.3 ICW3

The third write in the sequence (ICW3) has a different meaning for each controller.

- For the master controller, ICW3 is used to indicate which IRQ input line is used to cascade the slave controller. Within the ICH8, IRQ2 is used. Therefore, bit 2 of ICW3 on the master controller is set to a 1, and the other bits are set to 0s.
- For the slave controller, ICW3 is the slave identification code used during an interrupt acknowledge cycle. On interrupt acknowledge cycles, the master controller broadcasts a code to the slave controller if the cascaded interrupt won arbitration on the master controller. The slave controller compares this identification code to the value stored in its ICW3, and if it matches, the slave controller assumes responsibility for broadcasting the interrupt vector.

#### 5.8.2.4 ICW4

The final write in the sequence (ICW4) must be programmed for both controllers. At the very least, bit 0 must be set to a 1 to indicate that the controllers are operating in an Intel Architecture-based system.

### 5.8.3 Operation Command Words (OCW)

These command words reprogram the Interrupt controller to operate in various interrupt modes.

- OCW1 masks and unmask interrupt lines.
- OCW2 controls the rotation of interrupt priorities when in rotating priority mode, and controls the EOI function.
- OCW3 is sets up ISR/IRR reads, enables/disables the special mask mode (SMM), and enables/disables polled interrupt mode.



## 5.8.4 Modes of Operation

### 5.8.4.1 Fully Nested Mode

In this mode, interrupt requests are ordered in priority from 0 through 7, with 0 being the highest. When an interrupt is acknowledged, the highest priority request is determined and its vector placed on the bus. Additionally, the ISR for the interrupt is set. This ISR bit remains set until: the processor issues an EOI command immediately before returning from the service routine; or if in AEIO mode, on the trailing edge of the second INTA#. While the ISR bit is set, all further interrupts of the same or lower priority are inhibited, while higher levels generate another interrupt. Interrupt priorities can be changed in the rotating priority mode.

### 5.8.4.2 Special Fully-Nested Mode

This mode is used in the case of a system where cascading is used, and the priority has to be conserved within each slave. In this case, the special fully-nested mode is programmed to the master controller. This mode is similar to the fully-nested mode with the following exceptions:

- When an interrupt request from a certain slave is in service, this slave is not locked out from the master's priority logic and further interrupt requests from higher priority interrupts within the slave are recognized by the master and initiate interrupts to the processor. In the normal-nested mode, a slave is masked out when its request is in service.
- When exiting the Interrupt Service routine, software has to check whether the interrupt serviced was the only one from that slave. This is done by sending a Non-Specific EOI command to the slave and then reading its ISR. If it is 0, a non-specific EOI can also be sent to the master.

### 5.8.4.3 Automatic Rotation Mode (Equal Priority Devices)

In some applications, there are a number of interrupting devices of equal priority. Automatic rotation mode provides for a sequential 8-way rotation. In this mode, a device receives the lowest priority after being serviced. In the worst case, a device requesting an interrupt has to wait until each of seven other devices are serviced at most once.

There are two ways to accomplish automatic rotation using OCW2; the Rotation on Non-Specific EOI Command (R=1, SL=0, EOI=1) and the rotate in automatic EOI mode which is set by (R=1, SL=0, EOI=0).

### 5.8.4.4 Specific Rotation Mode (Specific Priority)

Software can change interrupt priorities by programming the bottom priority. For example, if IRQ5 is programmed as the bottom priority device, then IRQ6 is the highest priority device. The Set Priority Command is issued in OCW2 to accomplish this, where: R=1, SL=1, and LO-L2 is the binary priority level code of the bottom priority device.

In this mode, internal status is updated by software control during OCW2. However, it is independent of the EOI command. Priority changes can be executed during an EOI command by using the Rotate on Specific EOI Command in OCW2 (R=1, SL=1, EOI=1 and LO-L2=IRQ level to receive bottom priority).

#### 5.8.4.5 Poll Mode

Poll mode can be used to conserve space in the interrupt vector table. Multiple interrupts that can be serviced by one interrupt service routine do not need separate vectors if the service routine uses the poll command. Poll mode can also be used to expand the number of interrupts. The polling interrupt service routine can call the appropriate service routine, instead of providing the interrupt vectors in the vector table. In this mode, the INTR output is not used and the microprocessor internal Interrupt Enable flip-flop is reset, disabling its interrupt input. Service to devices is achieved by software using a Poll command.

The Poll command is issued by setting P=1 in OCW3. The PIC treats its next I/O read as an interrupt acknowledge, sets the appropriate ISR bit if there is a request, and reads the priority level. Interrupts are frozen from the OCW3 write to the I/O read. The byte returned during the I/O read contains a 1 in bit 7 if there is an interrupt, and the binary code of the highest priority level in bits 2:0.

#### 5.8.4.6 Cascade Mode

The PIC in the ICH8 has one master 8259 and one slave 8259 cascaded onto the master through IRQ2. This configuration can handle up to 15 separate priority levels. The master controls the slaves through a three bit internal bus. In the ICH8, when the master drives 010b on this bus, the slave controller takes responsibility for returning the interrupt vector. An EOI command must be issued twice: once for the master and once for the slave.

#### 5.8.4.7 Edge and Level Triggered Mode

In ISA systems this mode is programmed using bit 3 in ICW1, which sets level or edge for the entire controller. In the ICH8, this bit is disabled and a new register for edge and level triggered mode selection, per interrupt input, is included. This is the Edge/Level control Registers ELCR1 and ELCR2.

If an ELCR bit is 0, an interrupt request will be recognized by a low-to-high transition on the corresponding IRQ input. The IRQ input can remain high without generating another interrupt. If an ELCR bit is 1, an interrupt request will be recognized by a high level on the corresponding IRQ input and there is no need for an edge detection. The interrupt request must be removed before the EOI command is issued to prevent a second interrupt from occurring.

In both the edge and level triggered modes, the IRQ inputs must remain active until after the falling edge of the first internal INTA#. If the IRQ input goes inactive before this time, a default IRQ7 vector is returned.

#### 5.8.4.8 End of Interrupt (EOI) Operations

An EOI can occur in one of two fashions: by a command word write issued to the PIC before returning from a service routine, the EOI command; or automatically when AEIOI bit in ICW4 is set to 1.

#### 5.8.4.9 Normal End of Interrupt

In normal EOI, software writes an EOI command before leaving the interrupt service routine to mark the interrupt as completed. There are two forms of EOI commands: Specific and Non-Specific. When a Non-Specific EOI command is issued, the PIC clears the highest ISR bit of those that are set to 1. Non-Specific EOI is the normal mode of operation of the PIC within the ICH8, as the interrupt being serviced currently is the interrupt entered with the interrupt acknowledge. When the PIC is operated in modes that preserve the fully nested structure, software can determine which ISR bit to clear





by issuing a Specific EOI. An ISR bit that is masked is not cleared by a Non-Specific EOI if the PIC is in the special mask mode. An EOI command must be issued for both the master and slave controller.

#### 5.8.4.10 Automatic End of Interrupt Mode

In this mode, the PIC automatically performs a Non-Specific EOI operation at the trailing edge of the last interrupt acknowledge pulse. From a system standpoint, this mode should be used only when a nested multi-level interrupt structure is not required within a single PIC. The AEOI mode can only be used in the master controller and not the slave controller.

### 5.8.5 Masking Interrupts

#### 5.8.5.1 Masking on an Individual Interrupt Request

Each interrupt request can be masked individually by the Interrupt Mask Register (IMR). This register is programmed through OCW1. Each bit in the IMR masks one interrupt channel. Masking IRQ2 on the master controller masks all requests for service from the slave controller.

#### 5.8.5.2 Special Mask Mode

Some applications may require an interrupt service routine to dynamically alter the system priority structure during its execution under software control. For example, the routine may wish to inhibit lower priority requests for a portion of its execution but enable some of them for another portion.

The special mask mode enables all interrupts not masked by a bit set in the Mask register. Normally, when an interrupt service routine acknowledges an interrupt without issuing an EOI to clear the ISR bit, the interrupt controller inhibits all lower priority requests. In the special mask mode, any interrupts may be selectively enabled by loading the Mask Register with the appropriate pattern. The special mask mode is set by OCW3 where: SSMM=1, SMM=1, and cleared where SSMM=1, SMM=0.

### 5.8.6 Steering PCI Interrupts

The ICH8 can be programmed to allow PIRQA#-PIRQH# to be internally routed to interrupts 3-7, 9-12, 14, or 15. The assignment is programmable through the PIRQx Route Control registers, located at 60-63h and 68-6Bh in Device 31:Function 0. One or more PIRQx# lines can be routed to the same IRQx input. If interrupt steering is not required, the Route registers can be programmed to disable steering.

The PIRQx# lines are defined as active low, level sensitive to allow multiple interrupts on a PCI board to share a single line across the connector. When a PIRQx# is routed to specified IRQ line, software must change the IRQ's corresponding ELCR bit to level sensitive mode. The ICH8 internally inverts the PIRQx# line to send an active high level to the PIC. When a PCI interrupt is routed onto the PIC, the selected IRQ can no longer be used by an active high device (through SERIRQ). However, active low interrupts can share their interrupt with PCI interrupts.

Internal sources of the PIRQs, including SCI and TCO interrupts, cause the external PIRQ to be asserted. The ICH8 receives the PIRQ input, like all of the other external sources, and routes it accordingly.



## 5.9 Advanced Programmable Interrupt Controller (APIC) (D31:F0)

In addition to the standard ISA-compatible PIC described in the previous chapter, the ICH8 incorporates the APIC. While the standard interrupt controller is intended for use in a uni-processor system, APIC can be used in either a uni-processor or multi-processor system.

### 5.9.1 Interrupt Handling

The I/O APIC handles interrupts very differently than the 8259. Briefly, these differences are:

- **Method of Interrupt Transmission.** The I/O APIC transmits interrupts through memory writes on the normal datapath to the processor, and interrupts are handled without the need for the processor to run an interrupt acknowledge cycle.
- **Interrupt Priority.** The priority of interrupts in the I/O APIC is independent of the interrupt number. For example, interrupt 10 can be given a higher priority than interrupt 3.
- **More Interrupts.** The I/O APIC in the ICH8 supports a total of 24 interrupts.
- **Multiple Interrupt Controllers.** The I/O APIC architecture allows for multiple I/O APIC devices in the system with their own interrupt vectors.

### 5.9.2 Interrupt Mapping

The I/O APIC within the ICH8 supports 24 APIC interrupts. Each interrupt has its own unique vector assigned by software. The interrupt vectors are mapped as follows, and match “Config 6” of the *Multi-Processor Specification*.

Table 53. APIC Interrupt Mapping (Sheet 1 of 2)

IRQ #	Via SERIRQ	Direct from Pin	Via PCI Message	Internal Modules
0	No	No	No	Cascade from 8259 #1
1	Yes	No	Yes	
2	No	No	No	8254 Counter 0, HPET #0 (legacy mode)
3	Yes	No	Yes	
4	Yes	No	Yes	
5	Yes	No	Yes	
6	Yes	No	Yes	
7	Yes	No	Yes	
8	No	No	No	RTC, HPET #1 (legacy mode)
9	Yes	No	Yes	Option for SCI, TCO
10	Yes	No	Yes	Option for SCI, TCO
11	Yes	No	Yes	HPET #2, Option for SCI, TCO
12	Yes	No	Yes	
13	No	No	No	FERR# logic
14	Yes	Yes <sup>1</sup>	Yes	Mobile Only: IDEIRQ (legacy mode, non-combined or combined mapped as primary), SATA Primary (legacy mode)



Table 53. APIC Interrupt Mapping (Sheet 2 of 2)

IRQ #	Via SERIRQ	Direct from Pin	Via PCI Message	Internal Modules
15	Yes	Yes	Yes	Mobile Only: IDEIRQ (legacy mode — combined, mapped as secondary), SATA Secondary (legacy mode)
16	PIRQA#	PIRQA#	Yes	Internal devices are routable; see <a href="#">Section 7.1.52</a> through <a href="#">Section 7.1.58</a> .
17	PIROB#	PIROB#		
18	PIROC#	PIROC#		
19	PIROD#	PIROD#		
20	N/A	PIROE#	Yes	Option for SCI, TCO, HPET #0,1,2. Other internal devices are routable; see <a href="#">Section 7.1.52</a> through <a href="#">Section 7.1.58</a> .
21	N/A	PIROF#		
22	N/A	PIROG#		
23	N/A	PIROH#		

**NOTES:**

1. Mobile Only: IDEIRQ can only be driven directly from the pin when in legacy IDE mode.
2. When programming the polarity of internal interrupt sources on the APIC, interrupts 0 through 15 receive active-high internal interrupt sources, while interrupts 16 through 23 receive active-low internal interrupt sources.
3. If IRQ 11 is used for HPET #2, software should ensure IRQ 11 is not shared with any other devices to assure the proper operation of HPET #2. ICH8 hardware does not prevent sharing of IRQ 11.

### 5.9.3 PCI / PCI Express\* Message-Based Interrupts

When external devices through PCI / PCI Express wish to generate an interrupt, they will send the message defined in the *PCI Express\* Base Specification*, Revision 1.0a for generating INTA# - INTD#. These will be translated internal assertions/de-assertions of INTA# - INTD#.

### 5.9.4 Front Side Bus Interrupt Delivery

For processors that support Front Side Bus (FSB) interrupt delivery, the ICH8 requires that the I/O APIC deliver interrupt messages to the processor in a parallel manner, rather than using the I/O APIC serial scheme.

This is done by the ICH8 writing (via DMI) to a memory location that is snooped by the processor(s). The processor(s) snoop the cycle to know which interrupt goes active.

The following sequence is used:

1. When the ICH8 detects an interrupt event (active edge for edge-triggered mode or a change for level-triggered mode), it sets or resets the internal IRR bit associated with that interrupt.
2. Internally, the ICH8 requests to use the bus in a way that automatically flushes upstream buffers. This can be internally implemented similar to a DMA device request.
3. The ICH8 then delivers the message by performing a write cycle to the appropriate address with the appropriate data. The address and data formats are described below in [Section 5.9.4.4](#).

**Note:** FSB Interrupt Delivery compatibility with processor clock control depends on the processor, not the ICH8.

#### 5.9.4.1 Edge-Triggered Operation

In this case, the “Assert Message” is sent when there is an inactive-to-active edge on the interrupt.

#### 5.9.4.2 Level-Triggered Operation

In this case, the “Assert Message” is sent when there is an inactive-to-active edge on the interrupt. If after the EOI the interrupt is still active, then another “Assert Message” is sent to indicate that the interrupt is still active.

#### 5.9.4.3 Registers Associated with Front Side Bus Interrupt Delivery

**Capabilities Indication:** The capability to support Front Side Bus interrupt delivery is indicated via ACPI configuration techniques. This involves the BIOS creating a data structure that gets reported to the ACPI configuration software.

#### 5.9.4.4 Interrupt Message Format

The ICH8 writes the message to PCI (and to the Host controller) as a 32-bit memory write cycle. It uses the formats shown in [Table 54](#) and [Table 55](#) for the address and data.

The local APIC (in the processor) has a delivery mode option to interpret Front Side Bus messages as a SMI in which case the processor treats the incoming interrupt as a SMI instead of as an interrupt. This does not mean that the ICH8 has any way to have a SMI source from ICH8 power management logic cause the I/O APIC to send an SMI message (there is no way to do this). The ICH8’s I/O APIC can only send interrupts due to interrupts which do not include SMI, NMI or INIT. This means that in IA32/IA64 based platforms, Front Side Bus interrupt message format delivery modes 010 (SMI/PMI), 100 (NMI), and 101 (INIT) as indicated in this section, must not be used and is not supported. Only the hardware pin connection is supported by ICH8.

**Table 54. Interrupt Message Address Format**

Bit	Description
31:20	Will always be FEEh
19:12	<b>Destination ID:</b> This is the same as bits 63:56 of the I/O Redirection Table entry for the interrupt associated with this message.
11:4	<b>Extended Destination ID:</b> This is the same as bits 55:48 of the I/O Redirection Table entry for the interrupt associated with this message.
3	<b>Redirection Hint:</b> This bit is used by the processor host bridge to allow the interrupt message to be redirected. 0 = The message will be delivered to the agent (processor) listed in bits 19:12. 1 = The message will be delivered to an agent with a lower interrupt priority This can be derived from bits 10:8 in the Data Field (see below). The Redirection Hint bit will be a 1 if bits 10:8 in the delivery mode field associated with corresponding interrupt are encoded as 001 (Lowest Priority). Otherwise, the Redirection Hint bit will be 0
2	<b>Destination Mode:</b> This bit is used only the Redirection Hint bit is set to 1. If the Redirection Hint bit and the Destination Mode bit are both set to 1, then the logical destination mode is used, and the redirection is limited only to those processors that are part of the logical group as based on the logical ID.
1:0	Will always be 00.



Table 55. Interrupt Message Data Format

Bit	Description
31:16	Will always be 0000h.
15	<b>Trigger Mode:</b> 1 = Level, 0 = Edge. Same as the corresponding bit in the I/O Redirection Table for that interrupt.
14	<b>Delivery Status:</b> 1 = Assert, 0 = Deassert. Only Assert messages are sent. This bit is always 1.
13:12	Will always be 00
11	<b>Destination Mode:</b> 1 = Logical. 0 = Physical. Same as the corresponding bit in the I/O Redirection Table for that interrupt.
10:8	<b>Delivery Mode:</b> Same as the corresponding bits in the I/O Redirection Table for that interrupt. 000 = Fixed 100 = NMI    010 = SMI/PMI 110 = Reserved 001 = Lowest Priority 101 = INIT    011 = Reserved 111 = ExtINT
7:0	<b>Vector:</b> Same as the corresponding bits in the I/O Redirection Table for that interrupt.

## 5.10 Serial Interrupt (D31:F0)

The ICH8 supports a serial IRQ scheme. This allows a single signal to be used to report interrupt requests. The signal used to transmit this information is shared between the host, the ICH8, and all peripherals that support serial interrupts. The signal line, SERIRQ, is synchronous to PCI clock, and follows the sustained tri-state protocol that is used by all PCI signals. This means that if a device has driven SERIRQ low, it will first drive it high synchronous to PCI clock and release it the following PCI clock. The serial IRQ protocol defines this sustained tri-state signaling in the following fashion:

- **S – Sample Phase.** Signal driven low
- **R – Recovery Phase.** Signal driven high
- **T – Turn-around Phase.** Signal released

The ICH8 supports a message for 21 serial interrupts. These represent the 15 ISA interrupts (IRQ0–1, 2–15), the four PCI interrupts, and the control signals SMI# and IOCHK#. The serial IRQ protocol does not support the additional APIC interrupts (20–23).

### Note:

Mobile Only: When the IDE controller is enabled or the SATA controller is configured for legacy IDE mode, IRQ14 and IRQ15 are expected to behave as ISA legacy interrupts, which cannot be shared (i.e., through the Serial Interrupt pin). If IRQ14 and IRQ15 are shared with Serial Interrupt pin, then abnormal system behavior may occur. For example, IRQ14/15 may not be detected by ICH8's interrupt controller.

### Notes on IRQ14 and IRQ15

IRQ14 and IRQ15 are special interrupts, used by the PATA or SATA controllers.

When in a legacy or Native mode, IRQ14 and IRQ15 are not accepted from the serial stream and instead come from these controllers.



### 5.10.1 Start Frame

The serial IRQ protocol has two modes of operation which affect the start frame. These two modes are: Continuous, where the ICH8 is solely responsible for generating the start frame; and Quiet, where a serial IRQ peripheral is responsible for beginning the start frame.

The mode that must first be entered when enabling the serial IRQ protocol is continuous mode. In this mode, the ICH8 asserts the start frame. This start frame is 4, 6, or 8 PCI clocks wide based upon the Serial IRQ Control Register, bits 1:0 at 64h in Device 31:Function 0 configuration space. This is a polling mode.

When the serial IRQ stream enters quiet mode (signaled in the Stop Frame), the SERIRQ line remains inactive and pulled up between the Stop and Start Frame until a peripheral drives the SERIRQ signal low. The ICH8 senses the line low and continues to drive it low for the remainder of the Start Frame. Since the first PCI clock of the start frame was driven by the peripheral in this mode, the ICH8 drives the SERIRQ line low for 1 PCI clock less than in continuous mode. This mode of operation allows for a quiet, and therefore lower power, operation.

### 5.10.2 Data Frames

Once the Start frame has been initiated, all of the SERIRQ peripherals must start counting frames based on the rising edge of SERIRQ. Each of the IRQ/DATA frames has exactly 3 phases of 1 clock each:

- **Sample Phase.** During this phase, the SERIRQ device drives SERIRQ low if the corresponding interrupt signal is low. If the corresponding interrupt is high, then the SERIRQ devices tri-state the SERIRQ signal. The SERIRQ line remains high due to pull-up resistors (there is no internal pull-up resistor on this signal, an external pull-up resistor is required). A low level during the IRQ0–1 and IRQ2–15 frames indicates that an active-high ISA interrupt is not being requested, but a low level during the PCI INT[A:D], SMI#, and IOCHK# frame indicates that an active-low interrupt is being requested.
- **Recovery Phase.** During this phase, the device drives the SERIRQ line high if in the Sample Phase it was driven low. If it was not driven in the sample phase, it is tri-stated in this phase.
- **Turn-around Phase.** The device tri-states the SERIRQ line

### 5.10.3 Stop Frame

After all data frames, a Stop Frame is driven by the ICH8. The SERIRQ signal is driven low by the ICH8 for 2 or 3 PCI clocks. The number of clocks is determined by the SERIRQ configuration register. The number of clocks determines the next mode:

Table 56. Stop Frame Explanation

Stop Frame Width	Next Mode
2 PCI clocks	<b>Quiet Mode.</b> Any SERIRQ device may initiate a Start Frame
3 PCI clocks	<b>Continuous Mode.</b> Only the host (Intel® ICH8) may initiate a Start Frame



## 5.10.4 Specific Interrupts Not Supported via SERIRQ

There are three interrupts seen through the serial stream that are not supported by the ICH8. These interrupts are generated internally, and are not sharable with other devices within the system. These interrupts are:

- IRQ0. Heartbeat interrupt generated off of the internal 8254 counter 0.
- IRQ8#. RTC interrupt can only be generated internally.
- IRQ13. Floating point error interrupt generated off of the processor assertion of FERR#.

The ICH8 ignores the state of these interrupts in the serial stream, and does not adjust their level based on the level seen in the serial stream.

## 5.10.5 Data Frame Format

Table 57 shows the format of the data frames. For the PCI interrupts (A–D), the output from the ICH8 is AND'd with the PCI input signal. This way, the interrupt can be signaled via both the PCI interrupt input signal and via the SERIRQ signal (they are shared).

Table 57. Data Frame Format

Data Frame #	Interrupt	Clocks Past Start Frame	Comment
1	IRQ0	2	Ignored. IRQ0 can only be generated via the internal 8254
2	IRQ1	5	
3	SMI#	8	Causes SMI# if low. Will set the SERIRQ_SMI_STS bit.
4	IRQ3	11	
5	IRQ4	14	
6	IRQ5	17	
7	IRQ6	20	
8	IRQ7	23	
9	IRQ8	26	Ignored. IRQ8# can only be generated internally.
10	IRQ9	29	
11	IRQ10	32	
12	IRQ11	35	
13	IRQ12	38	
14	IRQ13	41	Ignored. IRQ13 can only be generated from FERR#
15	IRQ14	44	Not attached to PATA (Mobile Only) or SATA logic
16	IRQ15	47	Not attached to PATA (Mobile Only) or SATA logic
17	IOCHCK#	50	Same as ISA IOCHCK# going active.
18	PCI INTA#	53	Drive PIRQA#
19	PCI INTB#	56	Drive PIRQB#
20	PCI INTC#	59	Drive PIRQC#
21	PCI INTD#	62	Drive PIRQD#

## 5.11 Real Time Clock (D31:F0)

The Real Time Clock (RTC) module provides a battery backed-up date and time keeping device with two banks of static RAM with 128 bytes each, although the first bank has 114 bytes for general purpose usage. Three interrupt features are available: time of day alarm with once a second to once a month range, periodic rates of 122  $\mu$ s to 500 ms, and end of update cycle notification. Seconds, minutes, hours, days, day of week, month, and year are counted. Daylight savings compensation is available. The hour is represented in twelve or twenty-four hour format, and data can be represented in BCD or binary format. The design is functionally compatible with the Motorola MS146818B. The time keeping comes from a 32.768 kHz oscillating source, which is divided to achieve an update every second. The lower 14 bytes on the lower RAM block has very specific functions. The first ten are for time and date information. The next four (0Ah to 0Dh) are registers, which configure and report RTC functions.

The time and calendar data should match the data mode (BCD or binary) and hour mode (12 or 24 hour) as selected in register B. It is up to the programmer to make sure that data stored in these locations is within the reasonable values ranges and represents a possible date and time. The exception to these ranges is to store a value of C0–FFh in the Alarm bytes to indicate a don't care situation. All Alarm conditions must match to trigger an Alarm Flag, which could trigger an Alarm Interrupt if enabled. The SET bit must be 1 while programming these locations to avoid clashes with an update cycle. Access to time and date information is done through the RAM locations. If a RAM read from the ten time and date bytes is attempted during an update cycle, the value read do not necessarily represent the true contents of those locations. Any RAM writes under the same conditions are ignored.

**Note:** The leap year determination for adding a 29th day to February does not take into account the end-of-the-century exceptions. The logic simply assumes that all years divisible by 4 are leap years. According to the Royal Observatory Greenwich, years that are divisible by 100 are typically not leap years. In every fourth century (years divisible by 400, like 2000), the 100-year-exception is over-ridden and a leap-year occurs. Note that the year 2100 will be the first time in which the current RTC implementation would incorrectly calculate the leap-year.

The ICH8 does not implement month/year alarms.

### 5.11.1 Update Cycles

An update cycle occurs once a second, if the SET bit of register B is not asserted and the divide chain is properly configured. During this procedure, the stored time and date are incremented, overflow is checked, a matching alarm condition is checked, and the time and date are rewritten to the RAM locations. The update cycle will start at least 488  $\mu$ s after the UIP bit of register A is asserted, and the entire cycle does not take more than 1984  $\mu$ s to complete. The time and date RAM locations (0–9) are disconnected from the external bus during this time.

To avoid update and data corruption conditions, external RAM access to these locations can safely occur at two times. When a updated-ended interrupt is detected, almost 999 ms is available to read and write the valid time and date data. If the UIP bit of Register A is detected to be low, there is at least 488  $\mu$ s before the update cycle begins.

**Warning:** The overflow conditions for leap years and daylight savings adjustments are based on more than one date or time item. To ensure proper operation when adjusting the time, the new time and data values should be set at least two seconds before one of these conditions (leap year, daylight savings time adjustments) occurs.





## 5.11.2 Interrupts

The real-time clock interrupt is internally routed within the ICH8 both to the I/O APIC and the 8259. It is mapped to interrupt vector 8. This interrupt does not leave the ICH8, nor is it shared with any other interrupt. IRQ8# from the SERIRQ stream is ignored. However, the High Performance Event Timers can also be mapped to IRQ8#; in this case, the RTC interrupt is blocked.

## 5.11.3 Lockable RAM Ranges

The RTC's battery-backed RAM supports two 8-byte ranges that can be locked via the configuration space. If the locking bits are set, the corresponding range in the RAM will not be readable or writable. A write cycle to those locations will have no effect. A read cycle to those locations will not return the location's actual value (resultant value is undefined).

Once a range is locked, the range can be unlocked only by a hard reset, which will invoke the BIOS and allow it to relock the RAM range.

## 5.11.4 Century Rollover

The ICH8 detects a rollover when the Year byte (RTC I/O space, index offset 09h) transitions from 99 to 00. Upon detecting the rollover, the ICH8 sets the NEWCENTURY\_STS bit (TCOBASE + 04h, bit 7). If the system is in an S0 state, this causes an SMI#. The SMI# handler can update registers in the RTC RAM that are associated with century value. If the system is in a sleep state (S1–S5) when the century rollover occurs, the ICH8 also sets the NEWCENTURY\_STS bit, but no SMI# is generated. When the system resumes from the sleep state, BIOS should check the NEWCENTURY\_STS bit and update the century value in the RTC RAM.

## 5.11.5 Clearing Battery-Backed RTC RAM

Clearing CMOS RAM in an ICH8-based platform can be done by using a jumper on RTCRST# or GPI. Implementations should not attempt to clear CMOS by using a jumper to pull VccRTC low.

### Using RTCRST# to Clear CMOS

A jumper on RTCRST# can be used to clear CMOS values, as well as reset to default, the state of those configuration bits that reside in the RTC power well. When the RTCRST# is strapped to ground, the RTC\_PWR\_STS bit (D31:F0:A4h bit 2) will be set and those configuration bits in the RTC power well will be set to their default state. BIOS can monitor the state of this bit, and manually clear the RTC CMOS array once the system is booted. The normal position would cause RTCRST# to be pulled up through a weak pull-up resistor. Table 58 shows which bits are set to their default state when RTCRST# is asserted. This RTCRST# jumper technique allows the jumper to be moved and then replaced—all while the system is powered off. Then, once booted, the RTC\_PWR\_STS can be detected in the set state.

**Table 58. Configuration Bits Reset by RTCRST# Assertion (Sheet 1 of 2)**

Bit Name	Register	Location	Bit(s)	Default State
Alarm Interrupt Enable (AIE)	Register B (General Configuration) (RTC_REGB)	I/O space (RTC Index + 0Bh)	5	X
Alarm Flag (AF)	Register C (Flag Register) (RTC_REGC)	I/O space (RTC Index + 0Ch)	5	X
SWSMI_RATE_SEL	General PM Configuration 3 Register (GEN_PMCON_3)	D31:F0:A4h	7:6	0
SLP_S4# Minimum Assertion Width	General PM Configuration 3 Register (GEN_PMCON_3)	D31:F0:A4h	5:4	0
SLP_S4# Assertion Stretch Enable	General PM Configuration 3 Register (GEN_PMCON_3)	D31:F0:A4h	3	0
RTC Power Status (RTC_PWR_STS)	General PM Configuration 3 Register (GEN_PMCON_3)	D31:F0:A4h	2	0
Power Failure (PWR_FLR)	General PM Configuration 3 Register (GEN_PMCON_3)	D31:F0:A4h	1	0
AFTERG3_EN	General PM Configuration 3 Register (GEN_PMCON_3)	D31:F0:A4h	0	0
Power Button Override Status (PRBTNOR_STS)	Power Management 1 Status Register (PM1_STS)	PMBase + 00h	11	0
RTC Event Enable (RTC_EN)	Power Management 1 Enable Register (PM1_EN)	PMBase + 02h	10	0
Sleep Type (SLP_TYP)	Power Management 1 Control (PM1_CNT)	PMBase + 04h	12:10	0
PME_EN	General Purpose Event 0 Enables Register (GPE0_EN)	PMBase + 2Ch	11	0
BATLOW_EN	General Purpose Event 0 Enables Register (GPE0_EN)	PMBase + 2Ch	10	0
RI_EN	General Purpose Event 0 Enables Register (GPE0_EN)	PMBase + 2Ch	8	0


**Table 58. Configuration Bits Reset by RTCRST# Assertion (Sheet 2 of 2)**

Bit Name	Register	Location	Bit(s)	Default State
NEWCENTURY_STS	TCO1 Status Register (TCO1_STS)	TCOBase + 04h	7	0
Intruder Detect (INTRD_DET)	TCO2 Status Register (TCO2_STS)	TCOBase + 06h	0	0
Top Swap (TS)	Backed Up Control Register (BUC)	Chipset Configuration Registers: Offset 3414h	0	X
PATA Reset State (PRS) (Mobile Only)	Backed Up Control Register (BUC)	Chipset Configuration Registers: Offset 3414h	1	1

### Using a GPI to Clear CMOS

A jumper on a GPI can also be used to clear CMOS values. BIOS would detect the setting of this GPI on system boot-up, and manually clear the CMOS array.

**Note:** The GPI strap technique to clear CMOS requires multiple steps to implement. The system is booted with the jumper in new position, then powered back down. The jumper is replaced back to the normal position, then the system is rebooted again.

**Warning:** Clearing CMOS, using a jumper on VccRTC, must **not** be implemented.

## 5.12 Processor Interface (D31:F0)

The ICH8 interfaces to the processor with a variety of signals

- Standard Outputs to processor: A20M#, SMI#, NMI, INIT#, INTR, STPCLK#, IGNNE#, CPUSLP#, CPUPWRGD
- Standard Input from processor: FERR#
- Intel SpeedStep<sup>®</sup> technology output to processor: CPUPWRGOOD (In mobile configurations)

Most ICH8 outputs to the processor use standard buffers. The ICH8 has separate V<sub>CPU\_IO</sub> signals that are pulled up at the system level to the processor voltage, and thus determines VOH for the outputs to the processor.

### 5.12.1 Processor Interface Signals

This section describes each of the signals that interface between the ICH8 and the processor(s). Note that the behavior of some signals may vary during processor reset, as the signals are used for frequency strapping.

#### 5.12.1.1 A20M# (Mask A20)

The A20M# signal is active (low) when both of the following conditions are true:

- The ALT\_A20\_GATE bit (Bit 1 of PORT92 register) is a 0
- The A20GATE input signal is a 0

The A20GATE input signal is expected to be generated by the external microcontroller (KBC).



### 5.12.1.2 INIT# (Initialization)

The INIT# signal is active (driven low) based on any one of several events described in Table 59. When any of these events occur, INIT# is driven low for 16 PCI clocks, then driven high.

**Note:** The 16-clock counter for INIT# assertion halts while STPCLK# is active. Therefore, if INIT# is supposed to go active while STPCLK# is asserted, it actually goes active after STPCLK# goes inactive.

This section refers to INIT#, but applies to two signals: INIT# and INIT3\_3V# (Desktop Only), as INIT3\_3V# (Desktop Only) is functionally identical to INIT#, but signaling at 3.3 V.

**Table 59. INIT# Going Active**

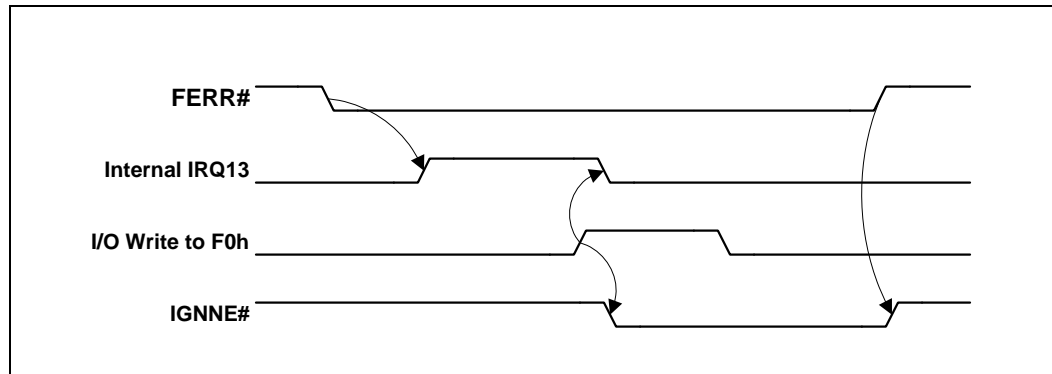
Cause of INIT# Going Active	Comment
Shutdown special cycle from processor observed on ICH-GMCH interconnect (from GMCH).	INIT# assertion based on value of Shutdown Policy Select register (SPS)
PORT92 write, where INIT_NOW (bit 0) transitions from a 0 to a 1.	
PORTCF9 write, where SYS_RST (bit 1) was a 0 and RST_CPU (bit 2) transitions from 0 to 1.	
RCIN# input signal goes low. RCIN# is expected to be driven by the external microcontroller (KBC).	0 to 1 transition on RCIN# must occur before the Intel® ICH8 will arm INIT# to be generated again. <b>NOTE:</b> RCIN# signal is expected to be low during S3, S4, and S5 states. Transition on the RCIN# signal in those states (or the transition to those states) may not necessarily cause the INIT# signal to be generated to the processor.
CPU BIST	To enter BIST, software sets CPU_BIST_EN bit and then does a full processor reset using the CF9 register.



### 5.12.1.3 FERR#/IGNNE# (Numeric Coprocessor Error/ Ignore Numeric Error)

The ICH8 supports the coprocessor error function with the FERR#/IGNNE# pins. The function is enabled via the COPROC\_ERR\_EN bit (Chipset Config Registers: Offset 31FFh: bit 1). FERR# is tied directly to the Coprocessor Error signal of the processor. If FERR# is driven active by the processor, IRQ13 goes active (internally). When it detects a write to the COPROC\_ERR register (I/O Register F0h), the ICH8 negates the internal IRQ13 and drives IGNNE# active. IGNNE# remains active until FERR# is driven inactive. IGNNE# is never driven active unless FERR# is active.

Figure 10. Coprocessor Error Timing Diagram



If COPROC\_ERR\_EN is not set, the assertion of FERR# will not generate an internal IRQ13, nor will the write to F0h generate IGNNE#.

### 5.12.1.4 NMI (Non-Maskable Interrupt)

Non-Maskable Interrupts (NMIs) can be generated by several sources, as described in Table 60.

Table 60. NMI Sources

Cause of NMI	Comment
SERR# goes active (either internally, externally via SERR# signal, or via message from (G)MCH)	Can instead be routed to generate an SCI, through the NMI2SCI_EN bit (Device 31:Function 0, TCO Base + 08h, bit 11).
IOCHK# goes active via SERIRQ# stream (ISA system Error)	Can instead be routed to generate an SCI, through the NMI2SCI_EN bit (Device 31:Function 0, TCO Base + 08h, bit 11).

### 5.12.1.5 Stop Clock Request and CPU Sleep (STPCLK# and CPUSLP#)

The ICH8 power management logic controls these active-low signals. Refer to Section 5.13 for more information on the functionality of these signals.

### 5.12.1.6 CPU Power Good (CPUPWRGOOD)

This signal is connected to the processor's PWRGOOD input. This signal represents a logical AND of the ICH8's PWROK and VRMPWRGD signals.



### 5.12.1.7 Deeper Sleep (DPSLP#) (Mobile Only)

This active-low signal controls the internal gating of the processor's core clock. This signal asserts before and deasserts after the STP\_CPU# signal to effectively stop the processor's clock (internally) in the states in which STP\_CPU# can be used to stop the processor's clock externally.

## 5.12.2 Dual-Processor Issues (Desktop Only)

### 5.12.2.1 Signal Differences

In dual-processor designs, some of the processor signals are unused or used differently than for uniprocessor designs.

Table 61. DP Signal Differences

Signal	Difference
A20M# / A20GATE	Generally not used, but still supported by Intel® ICH8.
STPCLK#	Used for S1 State as well as preparation for entry to S3–S5 Also allows for THERM# based throttling (not via ACPI control methods). Should be connected to both processors.
FERR# / IGNNE#	Generally not used, but still supported by ICH8.

### 5.12.2.2 Power Management

For multiple-processor (or Multiple-core) configurations in which more than one Stop Grant cycle may be generated, the (G)MCH is expected to count Stop Grant cycles and only pass the last one through to the ICH8. This prevents the ICH8 from getting out of sync with the processor on multiple STPCLK# assertions.

Because the S1 state will have the STPCLK# signal active, the STPCLK# signal can be connected to both processors. However, for ACPI implementations, the BIOS must indicate that the ICH8 only supports the C1 state for dual-processor designs.

In going to the S1 state for desktop, multiple Stop-Grant cycles will be generated by the processors. The Intel ICH8 also has the option to assert the processor's SLP# signal (CPUSLP#). It is assumed that prior to setting the SLP\_EN bit (which causes the transition to the S1 state), the processors will not be executing code that is likely to delay the Stop-Grant cycles.

In going to the S3, S4, or S5 states, the system will appear to pass through the S1 state; thus, STPCLK# and SLP# are also used. During the S3, S4, and S5 states, both processors will lose power. Upon exit from those states, the processors will have their power restored.



## 5.13 Power Management (D31:F0)

### 5.13.1 Features

- Support for *Advanced Configuration and Power Interface, Version 2.0 (ACPI)* providing power and thermal management
  - ACPI 24-Bit Timer
  - Software initiated throttling of processor performance for Thermal and Power Reduction
  - Hardware Override to throttle processor performance if system too hot
  - SCI and SMI# Generation
- PCI PME# signal for Wake Up from Low-Power states
- System Clock Control
  - (Mobile Only) ACPI C2 state: Stop Grant (using STPCLK# signal) halts processor's instruction stream
  - (Mobile Only) ACPI C3 State: Ability to halt processor clock (but not memory clock)
  - (Mobile Only) ACPI C4 State: Ability to lower processor voltage.
  - (Mobile Only) CLKRUN# Protocol for PCI Clock Starting/Stopping
- System Sleep State Control
  - ACPI S1 state: Stop Grant (using STPCLK# signal) halts processor's instruction stream (only STPCLK# active, and CPUSLP# optional)
  - ACPI S3 state — Suspend to RAM (STR)
  - ACPI S4 state — Suspend-to-Disk (STD)
  - ACPI G2/S5 state — Soft Off (SOFF)
  - Power Failure Detection and Recovery
- Manageability Engine Power Management Support
  - New Wake events from the ME (enabled from all S-States including Catastrophic S5 conditions)
- Streamlined Legacy Power Management for APM-Based Systems



### 5.13.2 Intel® ICH8 and System Power States

Table 62 shows the power states defined for ICH8-based platforms. The state names generally match the corresponding ACPI states.

Table 62. General Power States for Systems Using Intel® ICH8

State/ Substates	Legacy Name / Description
G0/S0/C0	<b>Full On:</b> Processor operating. Individual devices may be shut down to save power. The different processor operating levels are defined by Cx states, as shown in Table 63. Within the C0 state, the Intel® ICH8 can throttle the processor using the STPCLK# signal to reduce power consumption. The throttling can be initiated by software or by the operating system or BIOS.
G0/S0/C1	<b>Auto-Halt:</b> Processor has executed an AutoHalt instruction and is not executing code. The processor snoops the bus and maintains cache coherency.
G0/S0/C2 (Mobile Only)	<b>Stop-Grant:</b> The STPCLK# signal goes active to the processor. The processor performs a Stop-Grant cycle, halts its instruction stream, and remains in that state until the STPCLK# signal goes inactive. In the Stop-Grant state, the processor snoops the bus and maintains cache coherency.
G0/S0/C3 (Mobile Only)	<b>Stop-Clock:</b> The STPCLK# signal goes active to the processor. The processor performs a Stop-Grant cycle, halts its instruction stream. ICH8 then asserts DPSLP# followed by STP_CPU#, which forces the clock generator to stop the processor clock. This is also used for Intel SpeedStep® technology support. Accesses to memory (by graphics, PCI, or internal units) is not permitted while in a C3 state.
G0/S0/C4 (Mobile Only)	<b>Stop-Clock with Lower Processor Voltage:</b> This closely resembles the G0/S0/C3 state. However, after the ICH8 has asserted STP_CPU#, it then lowers the voltage to the processor. This reduces the leakage on the processor. Prior to exiting the C4 state, the ICH8 increases the voltage to the processor.
G1/S1	<b>Stop-Grant:</b> Similar to G0/S0/C2 state. ICH8 also has the option to assert the CPUSLP# signal to further reduce processor power consumption. <b>NOTE:</b> The behavior for this state is slightly different when supporting iA64 processors.
G1/S3	<b>Suspend-To-RAM (STR):</b> The system context is maintained in system DRAM, but power is shut off to non-critical circuits. Memory is retained, and refreshes continue. All clocks stop except RTC clock.
G1/S4	<b>Suspend-To-Disk (STD):</b> The context of the system is maintained on the disk. All power is then shut off to the system except for the logic required to resume.
G2/S5	<b>Soft Off (SOFF):</b> System context is not maintained. All power is shut off except for the logic required to restart. A full boot is required when waking.
G3	<b>Mechanical Off (MOFF):</b> System context not maintained. All power is shut off except for the RTC. No "Wake" events are possible, because the system does not have any power. This state occurs if the user removes the batteries, turns off a mechanical switch, or if the system power supply is at a level that is insufficient to power the "waking" logic. When system power returns, transition will depend on the state just prior to the entry to G3 and the AFTERG3 bit in the GEN_PMCON3 register (D31:F0, offset A4). Refer to Table 70 for more details.

Table 63 shows the transitions rules among the various states. Note that transitions among the various states may appear to temporarily transition through intermediate states. For example, in going from S0 to S1, it may appear to pass through the G0/S0/C2 states. These intermediate transitions and states are not listed in the table.





**Table 63. State Transition Rules for Intel® ICH8**

Present State	Transition Trigger	Next State
G0/S0/C0	<ul style="list-style-type: none"> <li>Processor halt instruction</li> <li>Level 2 Read (Mobile Only)</li> <li>Level 3 Read (Mobile Only)</li> <li>Level 4 Read (Mobile Only)</li> <li>SLP_EN bit set</li> <li>Power Button Override</li> <li>Mechanical Off/Power Failure</li> </ul>	<ul style="list-style-type: none"> <li>G0/S0/C1</li> <li>G0/S0/C2</li> <li>G0/S0/C2, G0/S0/C3 or G0/S0/C4 - depending on C4onC3_EN bit (D31:F0: Offset A0h: bit 7) and BM_STS_ZERO_EN bit (D31:F0: Offset A9h: bit 2) (Mobile Only)</li> <li>G1/Sx or G2/S5 state</li> <li>G2/S5</li> <li>G3</li> </ul>
G0/S0/C1	<ul style="list-style-type: none"> <li>Any Enabled Break Event</li> <li>STPCLK# goes active</li> <li>Power Button Override</li> <li>Power Failure</li> </ul>	<ul style="list-style-type: none"> <li>G0/S0/C0</li> <li>G0/S0/C2</li> <li>G2/S5</li> <li>G3</li> </ul>
G0/S0/C2 (Mobile Only)	<ul style="list-style-type: none"> <li>Any Enabled Break Event</li> <li>Power Button Override</li> <li>Power Failure</li> <li>Previously in C3/C4 and bus masters idle</li> </ul>	<ul style="list-style-type: none"> <li>G0/S0/C0</li> <li>G2/S5</li> <li>G3</li> <li>C3 or C4 - depending on PDME bit (D31:F0: Offset A9h: bit 4)</li> </ul>
G0/S0/C3 (Mobile Only)	<ul style="list-style-type: none"> <li>Any Enabled Break Event</li> <li>Any Bus Master Event</li> <li>Power Button Override</li> <li>Power Failure</li> <li>Previously in C4 and bus masters idle</li> </ul>	<ul style="list-style-type: none"> <li>G0/S0/C0</li> <li>G0/S0/C2 - if PUME bit (D31:F0: Offset A9h: bit 3) is set, else G0/S0/C0</li> <li>G2/S5</li> <li>G3</li> <li>C4 - depending on PDME bit (D31:F0: Offset A9h: bit 4)</li> </ul>
G0/S0/C4 (Mobile Only)	<ul style="list-style-type: none"> <li>Any Enabled Break Event</li> <li>Any Bus Master Event</li> <li>Power Button Override</li> <li>Power Failure</li> </ul>	<ul style="list-style-type: none"> <li>G0/S0/C0</li> <li>G0/S0/C2 - if PUME bit (D31:F0: Offset A9h: bit 3) is set, else G0/S0/C0</li> <li>G2/S5</li> <li>G3</li> </ul>
G1/S1, G1/S3, or G1/S4	<ul style="list-style-type: none"> <li>Any Enabled Wake Event</li> <li>Power Button Override</li> <li>Power Failure</li> </ul>	<ul style="list-style-type: none"> <li>G0/S0/C0 (See Note 2)</li> <li>G2/S5</li> <li>G3</li> </ul>
G2/S5	<ul style="list-style-type: none"> <li>Any Enabled Wake Event</li> <li>Power Failure</li> </ul>	<ul style="list-style-type: none"> <li>G0/S0/C0 (See Note 2)</li> <li>G3</li> </ul>
G3	<ul style="list-style-type: none"> <li>Power Returns</li> </ul>	<ul style="list-style-type: none"> <li>Optional to go to S0/C0 (reboot) or G2/S5 (stay off until power button pressed or other wake event). (See Note 1 and 2)</li> </ul>

**NOTES:**

- Some wake events can be preserved through power failure.
- Transitions from the S1–S5 or G3 states to the S0 state are deferred until BATLOW# is inactive in mobile configurations.

### 5.13.3 System Power Planes

The system has several independent power planes, as described in [Table 64](#). Note that when a particular power plane is shut off, it should go to a 0 V level.

**Table 64. System Power Plane**

Plane	Controlled By	Description
CPU	SLP_S3# signal	The SLP_S3# signal can be used to cut the power to the processor completely. The DPRSLPVR support allows lowering the processor's voltage during the C4 state.
MAIN	SLP_S3# signal	When SLP_S3# goes active, power can be shut off to any circuit not required to wake the system from the S3 state. Since the S3 state requires that the memory context be preserved, power must be retained to the main memory. The processor, devices on the PCI bus, LPC I/F, and graphics will typically be shut off when the Main power plane is shut, although there may be small subsections powered.
MEMORY	SLP_S4# signal SLP_S5# signal	When the SLP_S4# goes active, power can be shut off to any circuit not required to wake the system from the S4. Since the memory context does not need to be preserved in the S4 state, the power to the memory can also be shut down. When SLP_S5# goes active, power can be shut to any circuit not required to wake the system from the S5 state. Since the memory context does not need to be preserved in the S5 state, the power to the memory can also be shut.
Link Controller	SLP_M#	This pin is asserted when the manageability platform goes to MOff. Depending on the platform, this pin may be used to control the (G)MCH, ICH8 controller link power planes, the clock chip power, and the SPI flash power.
DEVICE[n]	GPIO	Individual subsystems may have their own power plane. For example, GPIO signals may be used to control the power to disk drives, audio amplifiers, or the display screen.

### 5.13.4 SMI# /SCI Generation

On any SMI# event taking place, ICH8 asserts SMI# to the processor, which causes it to enter SMM space. SMI# remains active until the EOS bit is set. When the EOS bit is set, SMI# goes inactive for a minimum of 4 PCICLK. If another SMI event occurs, SMI# is driven active again.

The SCI is a level-mode interrupt that is typically handled by an ACPI-aware operating system. In non-APIC systems (which is the default), the SCI IRQ is routed to one of the 8259 interrupts (IRQ 9, 10, or 11). The 8259 interrupt controller must be programmed to level mode for that interrupt.

In systems using the APIC, the SCI can be routed to interrupts 9, 10, 11, 20, 21, 22, or 23. The interrupt polarity changes depending on whether it is on an interrupt shareable with a PIRQ or not (see [Section 9.1.3](#)). The interrupt remains asserted until all SCI sources are removed.

[Table 65](#) shows which events can cause an SMI# and SCI. Note that some events can be programmed to cause either an SMI# or SCI. The usage of the event for SCI (instead of SMI#) is typically associated with an ACPI-based system. Each SMI# or SCI source has a corresponding enable and status bit.



Table 65. Causes of SMI # and SCI (Sheet 1 of 2)

Cause	SCI	SMI	Additional Enables	Where Reported
PME#	Yes	Yes	PME_EN=1	PME_STS
PME_B0 (internal EHCI controller)	Yes	Yes	PME_B0_EN=1	PME_B0_STS
PCI Express* PME Messages	Yes	Yes	PCI_EXP_EN=1 (Not enabled for SMI)	PCI_EXP_STS
PCI Express Hot Plug Message	Yes	Yes	HOT_PLUG_EN=1 (Not enabled for SMI)	HOT_PLUG_STS
Power Button Press	Yes	Yes	PWRBTN_EN=1	PWRBTN_STS
Power Button Override (Note 7)	Yes	No	None	PRBTNOR_STS
RTC Alarm	Yes	Yes	RTC_EN=1	RTC_STS
Ring Indicate	Yes	Yes	RI_EN=1	RI_STS
USB#1 wakes	Yes	Yes	USB1_EN=1	USB1_STS
USB#2 wakes	Yes	Yes	USB2_EN=1	USB2_STS
USB#3 wakes	Yes	Yes	USB3_EN=1	USB3_STS
USB#4 wakes	Yes	Yes	USB4_EN=1	USB4_STS
USB#5 wakes	Yes	Yes	USB5_EN=1	USB5_STS
THRM# pin active	Yes	Yes	THRM_EN=1	THRM_STS
ACPI Timer overflow (2.34 sec.)	Yes	Yes	TMROF_EN=1	TMROF_STS
Any GPI	Yes	Yes	GPI[x]_Route=10 (SCI) GPI[x]_Route=01 (SMI) GPE0[x]_EN=1	GPI[x]_STS GPE0_STS
TCO SCI Logic	Yes	No	TCOSCI_EN=1	TCOSCI_STS
TCO SCI message from (G)MCH	Yes	No	none	MCHSCI_STS
TCO SMI Logic	No	Yes	TCO_EN=1	TCO_STS
TCO SMI — Year 2000 Rollover	No	Yes	none	NEWCENTURY_STS
TCO SMI — TCO TIMEROUT	No	Yes	none	TIMEOUT
TCO SMI — OS writes to TCO_DAT_IN register	No	Yes	none	OS_TCO_SMI
TCO SMI — Message from (G)MCH	No	Yes	none	MCHSMI_STS
TCO SMI — NMI occurred (and NMIs mapped to SMI)	No	Yes	NMI2SMI_EN=1	NMI2SMI_STS
TCO SMI — INTRUDER# signal goes active	No	Yes	INTRD_SEL=10	INTRD_DET
TCO SMI — Change of the BIOSWP bit from 0 to 1	No	Yes	BLD=1	BIOSWR_STS



Table 65. Causes of SMI# and SCI (Sheet 2 of 2)

Cause	SCI	SMI	Additional Enables	Where Reported
TCO SMI — Write attempted to BIOS	No	Yes	BIOSWP=1	BIOSWR_STS
BIOS_RLS written to	Yes	No	GBL_EN=1	GBL_STS
GBL_RLS written to	No	Yes	BIOS_EN=1	BIOS_STS
Write to B2h register	No	Yes	APMC_EN = 1	APM_STS
Periodic timer expires	No	Yes	PERIODIC_EN=1	PERIODIC_STS
64 ms timer expires	No	Yes	SWSMI_TMR_EN=1	SWSMI_TMR_STS
Enhanced USB Legacy Support Event	No	Yes	LEGACY_USB2_EN = 1	LEGACY_USB2_STS
Enhanced USB Intel Specific Event	No	Yes	INTEL_USB2_EN = 1	INTEL_USB2_STS
UHCI USB Legacy logic	No	Yes	LEGACY_USB_EN=1	LEGACY_USB_STS
Serial IRQ SMI reported	No	Yes	none	SERIRQ_SMI_STS
Device monitors match address in its range	No	Yes	none	DEVMON_STS, DEVACT_STS
SMBus Host Controller	No	Yes	SMB_SMI_EN Host Controller Enabled	SMBus host status reg.
SMBus Slave SMI message	No	Yes	none	SMBUS_SMI_STS
SMBus SMBALERT# signal active	No	Yes	none	SMBUS_SMI_STS
SMBus Host Notify message received	No	Yes	HOST_NOTIFY_INTREN	SMBUS_SMI_STS HOST_NOTIFY_STS
(Mobile Only) BATLOW# assertion	Yes	Yes	BATLOW_EN=1.	BATLOW_STS
Access microcontroller 62h/66h	No	Yes	MCSMI_EN	MCSMI_STS
SLP_EN bit written to 1	No	Yes	SMI_ON_SLP_EN=1	SMI_ON_SLP_EN_STS
USB Per-Port Registers Write Enable bit changes to 1.	No	Yes	USB2_EN=1, Write_Enable_SMI_Enabled=1	USB2_STS, Write Enable Status

**NOTES:**

1. SCI\_EN must be 1 to enable SCI. SCI\_EN must be 0 to enable SMI.
2. SCI can be routed to cause interrupt 9:11 or 20:23 (20:23 only available in APIC mode).
3. GBL\_SMI\_EN must be 1 to enable SMI.
4. EOS must be written to 1 to re-enable SMI for the next 1.
5. ICH8 must have SMI# fully enabled when ICH8 is also enabled to trap cycles. If SMI# is not enabled in conjunction with the trap enabling, then hardware behavior is undefined.
6. Only GPI[15:0] may generate an SMI# or SCI.
7. When a power button override first occurs, the system will transition immediately to S5. The SCI will only occur after the next wake to S0 if the residual status bit (PRBTNOR\_STS) is not cleared prior to setting SCI\_EN.



#### 5.13.4.1 PCI Express\* SCI

PCI Express ports and the (G)MCH (via DMI) have the ability to cause PME using messages. When a PME message is received, ICH8 will set the PCI\_EXP\_STS bit. If the PCI\_EXP\_EN bit is also set, the ICH8 can cause an SCI via the GPE1\_STS register.

#### 5.13.4.2 PCI Express\* Hot-Plug

PCI Express has a Hot-Plug mechanism and is capable of generating a SCI via the GPE1 register. It is also capable of generating an SMI. However, it is not capable of generating a wake event.

### 5.13.5 Dynamic Processor Clock Control

The ICH8 has extensive control for dynamically starting and stopping system clocks. The clock control is used for transitions among the various S0/Cx states, and processor throttling. Each dynamic clock control method is described in this section. The various sleep states may also perform types of non-dynamic clock control.

The ICH8 supports the ACPI C0 and C1 states (in desktop) or C0, C1, C2, C3, and C4 (in mobile) states.

The Dynamic Processor Clock control is handled using the following signals:

- STPCLK#: Used to halt processor instruction stream.
- (Mobile Only) STP\_CPU#: Used to stop processor's clock
- (Mobile Only) CPUSLP#: Asserted prior to STP\_CPU# (in stop grant mode)
- (Mobile Only) DPUSLP#: Used to force Deeper Sleep for processor.
- (Mobile Only) DPRSLPVR: Used to lower voltage of VRM during C4 state.
- (Mobile Only) DPRSTP#: Used to alert the processor of C4 state. Also works in conjunction with DPRSLPVR to communicate to the VRM whether a slow or fast voltage ramp should be used.

The C1 state is entered based on the processor performing an auto halt instruction.

(Mobile Only) The C2 state is entered based on the processor reading the Level 2 register in the ICH8. It can also be entered from C3 or C4 states if bus masters require snoops and the PUME bit (D31:F0: Offset A9h: bit 3) is set.

(Mobile Only) The C3 state is entered based on the processor reading the Level 3 register in the ICH8 and when the C4onC3\_EN bit is clear (D31:F0: Offset A0: bit 7). This state can also be entered after a temporary return to C2 from a prior C3 or C4 state.

(Mobile Only) The C4 state is entered based on the processor reading the Level 4 register in the ICH8, or by reading the Level 3 register when the C4onC3\_EN bit is set. This state can also be entered after a temporary return to C2 from a prior C4 state.

A C1 state in desktop or a C1, C2, C3 or C4 state in mobile ends due to a Break event. Based on the break event, the ICH8 returns the system to C0 state.

(Mobile Only) [Table 66](#) lists the possible break events from C2, C3, or C4. The break events from C1 are indicated in the processor's datasheet.

**Table 66. Break Events (Mobile Only)**

Event	Breaks from	Comment
Any unmasked interrupt goes active	C2, C3, C4	IRQ[0:15] when using the 8259s, IRQ[0:23] for I/O APIC. Since SCI is an interrupt, any SCI will also be a break event.
Any internal event that cause an NMI or SMI#	C2, C3, C4	Many possible sources
Any internal event that cause INIT# to go active	C2, C3, C4	Could be indicated by the keyboard controller via the RCIN input signal.
Any bus master request (internal, external or DMA, or BMBUSY#) goes active and BM_RLD=1 (D31:F0:Offset PMBASE+04h: bit 1)	C3, C4	Need to wake up processor so it can do snoops <b>NOTE:</b> If the PUME bit (D31:F0: Offset A9h: bit 3) is set, then bus master activity will NOT be treated as a break event. Instead, there will be a return only to the C2 state.
Processor Pending Break Event Indication	C2, C3, C4	Only available if FERR# enabled for break event indication (See FERR# Mux Enable in GCS, Chipset Config Registers: Offset 3410h: bit 6)

### 5.13.5.1 Slow C4 Exit (Mobile Only)

To eliminate the audible noise caused by aggressive voltage ramps when exiting C4 states at a regular, periodic frequency, the ICH8 supports a method to slow down the voltage ramp at the processor VR for certain break events. If enabled for this behavior, the ICH8 treats IRQ0 and IRQ8 as “slow” break events since both of these can be the system timer tick interrupt. Rather than carefully tracking the interrupt and timer configuration information to track the one correct interrupt, it was deemed acceptable to simplify the logic and slow the break exit sequence for both interrupts. Other break event sources invoke the normal exit timings.

The ICH8 indicates that a slow voltage ramp is desired by deasserting DPRSTP# (high) and leaving DPRSLPVR asserted (high). The normal voltage ramp rate is communicated by deasserting DPRSTP# (high) and deasserting DPRSLPVR (low).

The ICH8 waits an additional delay before starting the normal voltage ramp timer during the C4 exit sequence. If a “fast” break event occurs during the additional, slow-Exit time delay, the ICH8 quickly deasserts DPRSLPVR (low), thereby speeding up the voltage ramp and reducing the delay to a value that is typically seen by the device in the past. In the event that a fast break event and a slow break event occur together, the fast flow is taken.

The ICH8 provides enable for Slow C4 Exit as well as a programmable delay time.



### 5.13.5.2 Transition Rules among S0/Cx and Throttling States

The following priority rules and assumptions apply among the various S0/Cx and throttling states:

- Entry to any S0/Cx state is mutually exclusive with entry to any S1–S5 state. This is because the processor can only perform one register access at a time and Sleep states have higher priority than thermal throttling.
- When the SLP\_EN bit is set (system going to a S1 - S5 sleep state), the THTL\_EN and FORCE\_THTL bits can be internally treated as being disabled (no throttling while going to sleep state).
- (Mobile Only) If the THTL\_EN or FORCE\_THTL bits are set, and a Level 2, Level 3, or Level 4 read then occurs, the system should immediately go and stay in a C2, C3, or C4 state until a break event occurs. A Level 2, Level 3, or Level 4 read has higher priority than the software initiated throttling.
- (Mobile Only) After an exit from a C2, C3 or C4 state (due to a Break event), and if the THTL\_EN or FORCE\_THTL bits are still set, the system will continue to throttle STPCLK#. Depending on the time of break event, the first transition on STPCLK# active can be delayed by up to one THRM period (1024 PCI clocks = 30.72 µs).
- The Host controller must post Stop-Grant cycles in such a way that the processor gets an indication of the end of the special cycle prior to the ICH8 observing the Stop-Grant cycle. This ensures that the STPCLK# signals stays active for a sufficient period after the processor observes the response phase.
- (Mobile Only) If in the C1 state and the STPCLK# signal goes active, the processor will generate a Stop-Grant cycle, and the system should go to the C2 state. When STPCLK# goes inactive, it should return to the C1 state.

### 5.13.5.3 Deferred C3/C4 (Mobile Only)

Due to the new DMI protocol, if there is any bus master activity (other than true isoch), then the C0 to C3 transition will pause at the C2 state. ICH8 will keep the processor in a C2 state until:

- ICH8 sees no bus master activity.
- A break event occurs. In this case, the ICH8 will perform the C2 to C0 sequence. Note that bus master traffic is not a break event in this case.

To take advantage of the Deferred C3/C4 mode, the BM\_STS\_ZERO\_EN bit must be set. This will cause the BM\_STS bit to read as 0 even if some bus master activity is present. If this is not done, then the software may avoid even attempting to go to the C3 or C4 state if it sees the BM\_STS bit as 1.

If the PUME bit (D31:F0: Offset A9h: bit 3) is 0, then the ICH8 will treat bus master activity as a break event. When reaching the C2 state, if there is any bus master activity, the ICH8 will return the processor to a C0 state.

### 5.13.5.4 POPUP (Auto C3/C4 to C2) (Mobile Only)

When the PUME bit (D31:F0: Offset A9h: bit 3) is set, the ICH8 enables a mode of operation where standard (non-isoch) bus master activity will not be treated as a full break event from the C3 or C4 states. Instead, these will be treated merely as bus master events and return the platform to a C2 state, and thus allow snoops to be performed.

After returning to the C2 state, the bus master cycles will be sent to the (G)MCH, even if the ARB\_DIS bit is set.



#### 5.13.5.5 POPDOWN (Auto C2 to C3/C4) (Mobile Only)

After returning to the C2 state from C3/C4, if the PDME bit (D31:F0: Offset A9h: bit 4) is set, the platform can return to a C3 or C4 state (depending on where it was prior to going back up to C2). This behaves similar to the Deferred C3/C4 transition, and will keep the processor in a C2 state until:

- Bus masters are no longer active.
- A break event occurs. Note that bus master traffic is not a break event in this case.

#### 5.13.6 Dynamic PCI Clock Control (Mobile Only)

The PCI clock can be dynamically controlled independent of any other low-power state. This control is accomplished using the CLKRUN# protocol as described in the *PCI Mobile Design Guide*, and is transparent to software.

The Dynamic PCI Clock control is handled using the following signals:

- CLKRUN#: Used by PCI and LPC peripherals to request the system PCI clock to run
- STP\_PCI#: Used to stop the system PCI clock

**Note:** The 33 MHz clock to the ICH8 is “free-running” and is not affected by the STP\_PCI# signal.

##### 5.13.6.1 Conditions for Checking the PCI Clock

When there is a lack of PCI activity, the ICH8 has the capability to stop the PCI clocks to conserve power. “PCI activity” is defined as any activity that would require the PCI clock to be running.

Any of the following conditions will indicate that it is **not okay** to stop the PCI clock:

- Cycles on PCI or LPC
- Cycles of any internal device that would need to go on the PCI bus
- SERIRQ activity

##### Behavioral Description

- When there is a lack of activity (as defined above) for 29 PCI clocks, the ICH8 deasserts (drive high) CLKRUN# for 1 clock and then tri-states the signal.

##### 5.13.6.2 Conditions for Maintaining the PCI Clock

PCI masters or LPC devices that wish to maintain the PCI clock running will observe the CLKRUN# signal deasserted, and then must re-assert if (drive it low) within 3 clocks.

- When the ICH8 has tri-stated the CLKRUN# signal after deasserting it, the ICH8 then checks to see if the signal has been re-asserted (externally).
- After observing the CLKRUN# signal asserted for 1 clock, the ICH8 again starts asserting the signal.
- If an internal device needs the PCI bus, the ICH8 asserts the CLKRUN# signal.

##### 5.13.6.3 Conditions for Stopping the PCI Clock

- If no device re-asserts CLKRUN# once it has been deasserted for at least 6 clocks, the ICH8 stops the PCI clock by asserting the STP\_PCI# signal to the clock synthesizer.





#### 5.13.6.4 Conditions for Re-Starting the PCI Clock

- A peripheral asserts CLKRUN# to indicate that it needs the PCI clock re-started.
- When the ICH8 observes the CLKRUN# signal asserted for 1 (free running) clock, the ICH8 deasserts the STP\_PCI# signal to the clock synthesizer within 4 (free running) clocks.
- Observing the CLKRUN# signal asserted externally for 1 (free running) clock, the ICH8 again starts driving CLKRUN# asserted.

If an internal source requests the clock to be re-started, the ICH8 re-asserts CLKRUN#, and simultaneously deasserts the STP\_PCI# signal.

#### 5.13.6.5 LPC Devices and CLKRUN#

If an LPC device (of any type) needs the 33 MHz PCI clock, such as for LPC DMA or LPC serial interrupt, then it can assert CLKRUN#. Note that LPC devices running DMA or bus master cycles will not need to assert CLKRUN#, since the ICH8 asserts it on their behalf.

The LDRQ# inputs are ignored by the ICH8 when the PCI clock is stopped to the LPC devices in order to avoid misinterpreting the request. The ICH8 assumes that only one more rising PCI clock edge occurs at the LPC device after the assertion of STP\_PCI#. Upon deassertion of STP\_PCI#, the ICH8 assumes that the LPC device receives its first clock rising edge corresponding to the ICH8's second PCI clock rising edge after the deassertion.

### 5.13.7 Sleep States

#### 5.13.7.1 Sleep State Overview

The ICH8 directly supports different sleep states (S1–S5), which are entered by setting the SLP\_EN bit, or due to a Power Button press. The entry to the Sleep states is based on several assumptions:

- Entry to a Cx state is mutually exclusive with entry to a Sleep state. This is because the processor can only perform one register access at a time. A request to Sleep always has higher priority than throttling.
- Prior to setting the SLP\_EN bit, the software turns off processor-controlled throttling. Note that thermal throttling cannot be disabled, but setting the SLP\_EN bit disables thermal throttling (since S1–S5 sleep state has higher priority).
- The G3 state cannot be entered via any software mechanism. The G3 state indicates a complete loss of power.

#### 5.13.7.2 Initiating Sleep State

Sleep states (S1–S5) are initiated by:

- Masking interrupts, turning off all bus master enable bits, setting the desired type in the SLP\_TYP field, and then setting the SLP\_EN bit. The hardware then attempts to gracefully put the system into the corresponding Sleep state.
- Pressing the PWRBTN# Signal for more than 4 seconds to cause a Power Button Override event. In this case the transition to the S5 state is less graceful, since there are no dependencies on observing Stop-Grant cycles from the processor or on clocks other than the RTC clock
- Assertion of the THRMTRIP# signal will cause a transition to the S5 state. This can occur when system is in S0 or S1 state.

**Table 67. Sleep Types**

Sleep Type	Comment
S1	Intel® ICH8 asserts the STPCLK# signal. It also has the option to assert CPUSLP# signal. This lowers the processor's power consumption. No snooping is possible in this state.
S3	ICH8 asserts SLP_S3#. The SLP_S3# signal controls the power to non-critical circuits. Power is only retained to devices needed to wake from this sleeping state, as well as to the memory.
S4	ICH8 asserts SLP_S3# and SLP_S4#. The SLP_S4# signal shuts off the power to the memory subsystem. Only devices needed to wake from this state should be powered.
S5	Same power state as S4. ICH8 asserts SLP_S3#, SLP_S4# and SLP_S5#.

### 5.13.7.3 Exiting Sleep States

Sleep states (S1–S5) are exited based on Wake events. The Wake events forces the system to a full on state (S0), although some non-critical subsystems might still be shut off and have to be brought back manually. For example, the hard disk may be shut off during a sleep state, and have to be enabled via a GPIO pin before it can be used.

Upon exit from the ICH8-controlled Sleep states, the WAK\_STS bit is set. The possible causes of Wake Events (and their restrictions) are shown in Table 68.

**Note:** (Mobile Only) If the BATLOW# signal is asserted, ICH8 does not attempt to wake from an S1–S5 state, even if the power button is pressed. This prevents the system from waking when the battery power is insufficient to wake the system. Wake events that occur while BATLOW# is asserted are latched by the ICH8, and the system wakes after BATLOW# is deasserted.

**Table 68. Causes of Wake Events (Sheet 1 of 2)**

Cause	States Can Wake From	How Enabled
RTC Alarm	S1–S5 (Note 1)	Set RTC_EN bit in PM1_EN register
Power Button	S1–S5	Always enabled as Wake event
GPI[0:15]	S1–S5 (Note 1)	GPE0_EN register <b>NOTE:</b> GPI's that are in the core well are not capable of waking the system from sleep states where the core well is not powered.
Classic USB	S1–S5	Set USB1_EN, USB 2_EN, USB3_EN, and USB4_EN bits in GPE0_EN register
LAN	S1–S5	Will use PME#. Wake enable set with LAN logic.
RI#	S1–S5 (Note 1)	Set RI_EN bit in GPE0_EN register
Intel® High Definition Audio	S1–S5	Event Sets PME_B0_STS bit; PM_B0_EN must be enabled. Can not wake from S5 state if it was entered due to power failure or power button override.
Primary PME#	S1–S5 (Note 1)	PME_B0_EN bit in GPE0_EN register
Secondary PME#	S1–S5	Set PME_EN bit in GPE0_EN register.



Table 68. Causes of Wake Events (Sheet 2 of 2)

Cause	States Can Wake From	How Enabled
PCI_EXP_WAKE#	S1–S5	PCI_EXP_WAKE bit (Note 3)
PCI_EXP PME Message	S1	Must use the PCI Express* WAKE# pin rather than messages for wake from S3,S4, or S5.
SMBALERT#	S1–S5	Always enabled as Wake event
SMBus Slave Message	S1–S5	Wake/SMI# command always enabled as a Wake event. <b>NOTE:</b> SMBus Slave Message can wake the system from S1–S5, as well as from S5 due to Power Button Override.
SMBus Host Notify message received	S1–S5	HOST_NOTIFY_WKEN bit SMBus Slave Command register. Reported in the SMB_WAK_STS bit in the GPEO_STS register.

**NOTES:**

- This is a wake event from S5 only if the sleep state was entered by setting the SLP\_EN and SLP\_TYP bits via software, or if there is a power failure.
- If in the S5 state due to a power button override or THRMTRIP#, the possible wake events are due to Power Button, Hard Reset Without Cycling (See Command Type 3 in [Table 93](#)), and Hard Reset System (See Command Type 4 in [Table 93](#)).
- When the WAKE# pin is active and the PCI Express device is enabled to wake the system, the ICH8 will wake the platform.

It is important to understand that the various GPIs have different levels of functionality when used as wake events. The GPIs that reside in the core power well can only generate wake events from sleep states where the core well is powered. Also, only certain GPIs are “ACPI Compliant,” meaning that their Status and Enable bits reside in ACPI I/O space. [Table 69](#) summarizes the use of GPIs as wake events.

Table 69. GPI Wake Events

GPI	Power Well	Wake From	Notes
GPI[7:0]	Core	S1	ACPI Compliant
GPI[15:8]	Resume	S1–S5	ACPI Compliant

The latency to exit the various Sleep states varies greatly and is heavily dependent on power supply design, so much so that the exit latencies due to the ICH8 are insignificant.



#### 5.13.7.4 PCI Express\* WAKE# Signal and PME Event Message

PCI Express ports can wake the platform from any sleep state (S1, S3, S4, or S5) using the WAKE# pin. WAKE# is treated as a wake event, but does not cause any bits to go active in the GPE\_STS register.

PCI Express ports and the (G)MCH (via DMI) have the ability to cause PME using messages. When a PME message is received, ICH8 will set the PCI\_EXP\_STS bit.

#### 5.13.7.5 Sx-G3-Sx, Handling Power Failures

Depending on when the power failure occurs and how the system is designed, different transitions could occur due to a power failure.

The AFTER\_G3 bit provides the ability to program whether or not the system should boot once power returns after a power loss event. If the policy is to not boot, the system remains in an S5 state (unless previously in S4). There are only three possible events that will wake the system after a power failure.

1. **PWRBTN#:** PWRBTN# is always enabled as a wake event. When RSMRST# is low (G3 state), the PWRBTN\_STS bit is reset. When the ICH8 exits G3 after power returns (RSMRST# goes high), the PWRBTN# signal is already high (because V<sub>CC</sub>-standby goes high before RSMRST# goes high) and the PWRBTN\_STS bit is 0.
2. **RI#:** RI# does not have an internal pull-up. Therefore, if this signal is enabled as a wake event, it is important to keep this signal powered during the power loss event. If this signal goes low (active), when power returns the RI\_STS bit is set and the system interprets that as a wake event.
3. **RTC Alarm:** The RTC\_EN bit is in the RTC well and is preserved after a power loss. Like PWRBTN\_STS the RTC\_STS bit is cleared when RSMRST# goes low.

The ICH8 monitors both PWROK and RSMRST# to detect for power failures. If PWROK goes low, the PWROK\_FLR bit is set. If RSMRST# goes low, PWR\_FLR is set.

**Note:** Although PME\_EN is in the RTC well, this signal cannot wake the system after a power loss. PME\_EN is cleared by RTCRST#, and PME\_STS is cleared by RSMRST#.

**Table 70. Transitions Due to Power Failure**

State at Power Failure	AFTERG3_EN bit	Transition When Power Returns
S0, S1, S3	1	S5
	0	S0
S4	1	S4
	0	S0
S5	1	S5
	0	S0



## 5.13.8 Thermal Management

The ICH8 has mechanisms to assist with managing thermal problems in the system.

### 5.13.8.1 THRM# Signal

The THRM# signal is used as a status input for a thermal sensor. Based on the THRM# signal going active, the ICH8 generates an SMI# or SCI (depending on SCI\_EN).

If the THRM\_POL bit is set low, when the THRM# signal goes low, the THRM\_STS bit will be set. This is an indicator that the thermal threshold has been exceeded. If the THRM\_EN bit is set, then when THRM\_STS goes active, either an SMI# or SCI will be generated (depending on the SCI\_EN bit being set).

The power management software (BIOS or ACPI) can then take measures to start reducing the temperature. Examples include shutting off unwanted subsystems, or halting the processor.

By setting the THRM\_POL bit to high, another SMI# or SCI can optionally be generated when the THRM# signal goes back high. This allows the software (BIOS or ACPI) to turn off the cooling methods.

**Note:** THRM# assertion does not cause a TCO event message in S3 or S4. The level of the signal is not reported in the heartbeat message.

### 5.13.8.2 Software Initiated Passive Cooling

This mode is initiated by software setting the THTL\_EN or FORCE\_THTL bits.

Software sets the THTL\_DTY or THRM\_DTY bits to select throttle ratio and THTL\_EN or FORCE\_THTL bit to enable the throttling.

Throttling results in STPCLK# active for a minimum time of 12.5% and a maximum of 87.5%. The period is 1024 PCI clocks. Thus, the STPCLK# signal can be active for as little as 128 PCI clocks or as much as 896 PCI clocks. The actual slowdown (and cooling) of the processor depends on the instruction stream, because the processor is allowed to finish the current instruction. Furthermore, the ICH8 waits for the STOP-GRANT cycle before starting the count of the time the STPCLK# signal is active.

### 5.13.8.3 THRM# Override Software Bit

The FORCE\_THTL bit allows the BIOS to force passive cooling, independent of the ACPI software (which uses the THTL\_EN and THTL\_DTY bits). If this bit is set, the ICH8 starts throttling using the ratio in the THRM\_DTY field.

When this bit is cleared the ICH8 stops throttling, unless the THTL\_EN bit is set (indicating that ACPI software is attempting throttling).

If both the THTL\_EN and FORCE\_THTL bits are set, then the ICH8 should use the duty cycle defined by the THRM\_DTY field, not the THTL\_DTY field.

### 5.13.8.4 Active Cooling

Active cooling involves fans. The GPIO signals from the ICH8 can be used to turn on/off a fan.

### 5.13.9 Event Input Signals and Their Usage

The ICH8 has various input signals that trigger specific events. This section describes those signals and how they should be used.

#### 5.13.9.1 PWRBTN# (Power Button)

The ICH8 PWRBTN# signal operates as a “Fixed Power Button” as described in the *Advanced Configuration and Power Interface, Version 2.0b*. PWRBTN# signal has a 16 ms de-bounce on the input. The state transition descriptions are included in [Table 71](#). Note that the transitions start as soon as the PWRBTN# is pressed (but after the debounce logic), and does not depend on when the Power Button is released.

**Note:** During the time that the SLP\_S4# signal is stretched for the minimum assertion width (if enabled), the Power Button is not a wake event. Refer to Power Button Override Function section below for further detail.

**Table 71. Transitions Due to Power Button**

Present State	Event	Transition/Action	Comment
S0/Cx	PWRBTN# goes low	SMI# or SCI generated (depending on SCI_EN, PWRBTN_INIT_EN, PWRBTN_EN and GLB_SMI_EN)	Software typically initiates a Sleep state
S1–S5	PWRBTN# goes low	Wake Event. Transitions to S0 state	Standard wakeup
G3	PWRBTN# pressed	None	No effect since no power Not latched nor detected
S0–S4	PWRBTN# held low for at least 4 consecutive seconds	Unconditional transition to S5 state	No dependence on processor (e.g., Stop-Grant cycles) or any other subsystem

#### Power Button Override Function

If PWRBTN# is observed active for at least four consecutive seconds, the state machine should unconditionally transition to the G2/S5 state, regardless of present state (S0–S4), even if PWROK is not active. In this case, the transition to the G2/S5 state should not depend on any particular response from the processor (e.g., a Stop-Grant cycle), nor any similar dependency from any other subsystem.

The PWRBTN# status is readable to check if the button is currently being pressed or has been released. The status is taken after the de-bounce, and is readable via the PWRBTN\_LVL bit.

**Note:** The 4-second PWRBTN# assertion should only be used if a system lock-up has occurred. The 4-second timer starts counting when the ICH8 is in a S0 state. If the PWRBTN# signal is asserted and held active when the system is in a suspend state (S1–S5), the assertion causes a wake event. Once the system has resumed to the S0 state, the 4-second timer starts.

**Note:** During the time that the SLP\_S4# signal is stretched for the minimum assertion width (if enabled by D31:F0:A4h bit 3), the Power Button is not a wake event. As a result, it is conceivable that the user will press and continue to hold the Power Button waiting for the system to awake. Since a 4-second press of the Power Button is already defined as an Unconditional Power down, the power button timer will be forced to inactive while the power-cycle timer is in progress. Once the power-cycle timer has expired, the



Power Button awakes the system. Once the minimum SLP\_S4# power cycle expires, the Power Button must be pressed for another 4 to 5 seconds to create the Override condition to S5.

### Sleep Button

The *Advanced Configuration and Power Interface, Version 2.0b* defines an optional Sleep button. It differs from the power button in that it only is a request to go from S0 to S1–S4 (not S5). Also, in an S5 state, the Power Button can wake the system, but the Sleep Button cannot.

Although the ICH8 does not include a specific signal designated as a Sleep Button, one of the GPIO signals can be used to create a “Control Method” Sleep Button. See the *Advanced Configuration and Power Interface, Version 2.0b* for implementation details.

#### 5.13.9.2 RI# (Ring Indicator)

The Ring Indicator can cause a wake event (if enabled) from the S1–S5 states. [Table 72](#) shows when the wake event is generated or ignored in different states. If in the G0/S0/Cx states, the ICH8 generates an interrupt based on RI# active, and the interrupt will be set up as a Break event.

**Table 72. Transitions Due to RI# Signal**

Present State	Event	RI_EN	Event
S0	RI# Active	X	Ignored
S1–S5	RI# Active	0	Ignored
		1	Wake Event

**Note:** Filtering/Debounce on RI# will not be done in ICH8. Can be in modem or external.

#### 5.13.9.3 PME# (PCI Power Management Event)

The PME# signal comes from a PCI device to request that the system be restarted. The PME# signal can generate an SMI#, SCI, or optionally a Wake event. The event occurs when the PME# signal goes from high to low. No event is caused when it goes from low to high.

There is also an internal PME\_B0 bit. This is separate from the external PME# signal and can cause the same effect.

#### 5.13.9.4 SYS\_RESET# Signal

When the SYS\_RESET# pin is detected as active after the 16 ms debounce logic, the ICH8 attempts to perform a “graceful” reset, by waiting up to 25 ms for the SMBus to go idle. If the SMBus is idle when the pin is detected active, the reset occurs immediately; otherwise, the counter starts. If at any point during the count the SMBus goes idle the reset occurs. If, however, the counter expires and the SMBus is still active, a reset is forced upon the system even though activity is still occurring.

Once the reset is asserted, it remains asserted for 5 to 6 ms regardless of whether the SYSRESET# input remains asserted or not. It cannot occur again until SYS\_RESET# has been detected inactive after the debounce logic, and the system is back to a full S0 state with PLTRST# inactive. Note that if bit 3 of the CF9h I/O register is set then SYS\_RESET# will result in a full power cycle reset.



### 5.13.9.5 THRMTRIP# Signal

If THRMTRIP# goes active, the processor is indicating an overheat condition, and the ICH8 immediately transitions to an S5 state. However, since the processor has overheated, it does not respond to the ICH8's STPCLK# pin with a stop grant special cycle. Therefore, the ICH8 does not wait for one. Immediately upon seeing THRMTRIP# low, the ICH8 initiates a transition to the S5 state, drive SLP\_S3#, SLP\_S4#, SLP\_S5# low, and set the CTS bit. The transition looks like a power button override.

It is extremely important that when a THRMTRIP# event occurs, the ICH8 power down immediately without following the normal S0 -> S5 path. This path may be taken in parallel, but ICH8 must immediately enter a power down state. It does this by driving SLP\_S3#, SLP\_S4#, and SLP\_S5# immediately after sampling THRMTRIP# active.

If the processor is running extremely hot and is heating up, it is possible (although very unlikely) that components around it, such as the ICH8, are no longer executing cycles properly. Therefore, if THRMTRIP# goes active, and the ICH8 is relying on state machine logic to perform the power down, the state machine may not be working, and the system will not power down.

The ICH8 follows this flow for THRMTRIP#.

1. At boot (PLTRST# low), THRMTRIP# ignored.
2. After power-up (PLTRST# high), if THRMTRIP# sampled active, SLP\_S3#, SLP\_S4#, and SLP\_S5# assert, and normal sequence of sleep machine starts.
3. Until sleep machine enters the S5 state, SLP\_S3#, SLP\_S4#, and SLP\_S5# stay active, even if THRMTRIP# is now inactive. This is the equivalent of "latching" the thermal trip event.
4. If S5 state reached, go to step #1, otherwise stay here. If the ICH8 never reaches S5, the ICH8 does not reboot until power is cycled.

During boot, THRMTRIP# is ignored until SLP\_S3#, PWROK, VRMPWRGD/VGATE, and PLTRST# are all '1'. During entry into a powered-down state (due to S3, S4, S5 entry, power cycle reset, etc.) THRMTRIP# is ignored until either SLP\_S3# = 0, or PWROK = 0, or VRMPWRGD/VGATE = 0.

**Note:**

A thermal trip event will:

- Set the AFTERG3\_EN bit
- Clear the PWRBTN\_STS bit
- Clear all the GPE0\_EN register bits
- Clear the SMB\_WAK\_STS bit only if SMB\_SAK\_STS was set due to SMBus slave receiving message and not set due to SMBAlert

### 5.13.9.6 BMBUSY# (Mobile Only)

The BMBUSY# signal is an input from a graphics component to indicate if it is busy. If prior to going to the C3 state, the BMBUSY# signal is active, then the BM\_STS bit will be set. If after going to the C3 state, the BMBUSY# signal goes back active, the ICH8 will treat this as if one of the PCI REQ# signals went active. This is treated as a break event.





### 5.13.10 ALT Access Mode

Before entering a low power state, several registers from powered down parts may need to be saved. In the majority of cases, this is not an issue, as registers have read and write paths. However, several of the ISA compatible registers are either read only or write only. To get data out of write-only registers, and to restore data into read-only registers, the ICH8 implements an ALT access mode.

If the ALT access mode is entered and exited after reading the registers of the ICH8 timer (8254), the timer starts counting faster (13.5 ms). The following steps listed below can cause problems:

1. BIOS enters ALT access mode for reading the ICH8 timer related registers.
2. BIOS exits ALT access mode.
3. BIOS continues through the execution of other needed steps and passes control to the operating system.

After getting control in step #3, if the operating system does not reprogram the system timer again, the timer ticks may be happening faster than expected. For example DOS and its associated software assume that the system timer is running at 54.6 ms and as a result the time-outs in the software may be happening faster than expected.

Operating systems (e.g., Microsoft Windows\* 98, Windows\* 2000, and Windows NT\*) reprogram the system timer and therefore do not encounter this problem.

For some other loss (e.g., Microsoft MS-DOS\*) the BIOS should restore the timer back to 54.6 ms before passing control to the operating system. If the BIOS is entering ALT access mode before entering the suspend state it is not necessary to restore the timer contents after the exit from ALT access mode.

#### 5.13.10.1 Write Only Registers with Read Paths in ALT Access Mode

The registers described in [Table 73](#) have read paths in ALT access mode. The access number field in the table indicates which register will be returned per access to that port.



**Table 73. Write Only Registers with Read Paths in ALT Access Mode (Sheet 1 of 2)**

Restore Data				Restore Data			
I/O Addr	# of Rds	Access	Data	I/O Addr	# of Rds	Access	Data
00h	2	1	DMA Chan 0 base address low byte	40h	7	1	Timer Counter 0 status, bits [5:0]
		2	DMA Chan 0 base address high byte			2	Timer Counter 0 base count low byte
01h	2	1	DMA Chan 0 base count low byte			3	Timer Counter 0 base count high byte
		2	DMA Chan 0 base count high byte			4	Timer Counter 1 base count low byte
02h	2	1	DMA Chan 1 base address low byte			5	Timer Counter 1 base count high byte
		2	DMA Chan 1 base address high byte			6	Timer Counter 2 base count low byte
03h	2	1	DMA Chan 1 base count low byte			7	Timer Counter 2 base count high byte
		2	DMA Chan 1 base count high byte	41h	1	Timer Counter 1 status, bits [5:0]	
04h	2	1	DMA Chan 2 base address low byte	42h	1	Timer Counter 2 status, bits [5:0]	
		2	DMA Chan 2 base address high byte	70h	1	Bit 7 = NMI Enable, Bits [6:0] = RTC Address	
05h	2	1	DMA Chan 2 base count low byte	C4h	2	1	DMA Chan 5 base address low byte
		2	DMA Chan 2 base count high byte			2	DMA Chan 5 base address high byte
06h	2	1	DMA Chan 3 base address low byte	C6h	2	1	DMA Chan 5 base count low byte
		2	DMA Chan 3 base address high byte			2	DMA Chan 5 base count high byte
07h	2	1	DMA Chan 3 base count low byte	C8h	2	1	DMA Chan 6 base address low byte
		2	DMA Chan 3 base count high byte			2	DMA Chan 6 base address high byte



**Table 73. Write Only Registers with Read Paths in ALT Access Mode (Sheet 2 of 2)**

Restore Data				Restore Data				
I/O Addr	# of Rds	Access	Data	I/O Addr	# of Rds	Access	Data	
08h	6	1	DMA Chan 0–3 Command <sup>2</sup>	CAh	2	1	DMA Chan 6 base count low byte	
		2	DMA Chan 0–3 Request			2	DMA Chan 6 base count high byte	
		3	DMA Chan 0 Mode: Bits(1:0) = 00	CCh	2	1	DMA Chan 7 base address low byte	
		4	DMA Chan 1 Mode: Bits(1:0) = 01			2	DMA Chan 7 base address high byte	
		5	DMA Chan 2 Mode: Bits(1:0) = 10	CEh	2	1	DMA Chan 7 base count low byte	
		6	DMA Chan 3 Mode: Bits(1:0) = 11.			2	DMA Chan 7 base count high byte	
20h	12	1	PIC ICW2 of Master controller	D0h	6	1	DMA Chan 4–7 Command <sup>2</sup>	
		2	PIC ICW3 of Master controller			2	DMA Chan 4–7 Request	
		3	PIC ICW4 of Master controller			3	DMA Chan 4 Mode: Bits(1:0) = 00	
		4	PIC OCW1 of Master controller <sup>1</sup>			4	DMA Chan 5 Mode: Bits(1:0) = 01	
		5	PIC OCW2 of Master controller			5	DMA Chan 6 Mode: Bits(1:0) = 10	
		6	PIC OCW3 of Master controller			6	DMA Chan 7 Mode: Bits(1:0) = 11.	
		7	PIC ICW2 of Slave controller					
		8	PIC ICW3 of Slave controller					
		9	PIC ICW4 of Slave controller					
		10	PIC OCW1 of Slave controller <sup>1</sup>					
		11	PIC OCW2 of Slave controller					
		12	PIC OCW3 of Slave controller					

**NOTES:**

1. The OCW1 register must be read before entering ALT access mode.
2. Bits 5, 3, 1, and 0 return 0.

**5.13.10.2 PIC Reserved Bits**

Many bits within the PIC are reserved, and must have certain values written in order for the PIC to operate properly. Therefore, there is no need to return these values in ALT access mode. When reading PIC registers from 20h and A0h, the reserved bits shall return the values listed in [Table 74](#).

**Table 74. PIC Reserved Bits Return Values**

PIC Reserved Bits	Value Returned
ICW2(2:0)	000
ICW4(7:5)	000
ICW4(3:2)	00
ICW4(0)	0
OCW2(4:3)	00
OCW3(7)	0
OCW3(5)	Reflects bit 6
OCW3(4:3)	01

### 5.13.10.3 Read Only Registers with Write Paths in ALT Access Mode

The registers described in [Table 75](#) have write paths to them in ALT access mode. Software restores these values after returning from a powered down state. These registers must be handled special by software. When in normal mode, writing to the base address/count register also writes to the current address/count register. Therefore, the base address/count must be written first, then the part is put into ALT access mode and the current address/count register is written.

**Table 75. Register Write Accesses in ALT Access Mode**

I/O Address	Register Write Value
08h	DMA Status Register for channels 0–3.
D0h	DMA Status Register for channels 4–7.

## 5.13.11 System Power Supplies, Planes, and Signals

### 5.13.11.1 Power Plane Control with SLP\_S3#, SLP\_S4#, SLP\_S5# and SLP\_M#

The SLP\_S3# output signal can be used to cut power to the system core supply, since it only goes active for the STR state (typically mapped to ACPI S3). Power must be maintained to the ICH8 resume well, and to any other circuits that need to generate Wake signals from the STR state.

Cutting power to the core may be done via the power supply, or by external FETs to the motherboard.

The SLP\_S4# or SLP\_S5# output signal can be used to cut power to the system core supply, as well as power to the system memory, since the context of the system is saved on the disk. Cutting power to the memory may be done via the power supply, or by external FETs to the motherboard.

The SLP\_S4# output signal is used to remove power to additional subsystems that are powered during SLP\_S3#.

SLP\_S5# output signal can be used to cut power to the system core supply, as well as power to the system memory, since the context of the system is saved on the disk. Cutting power to the memory may be done via the power supply, or by external FETs to the motherboard.

SLP\_M# output signal can be used to cut power to the Link Controller, Clock chip or SPI flash on a platform that supports Intel AMT.



### 5.13.11.2 SLP\_S4# and Suspend-To-RAM Sequencing

The system memory suspend voltage regulator is controlled by the Glue logic. The SLP\_S4# signal should be used to remove power to system memory rather than the SLP\_S5# signal. The SLP\_S4# logic in the ICH8 provides a mechanism to fully cycle the power to the DRAM and/or detect if the power is not cycled for a minimum time.

**Note:** To utilize the minimum DRAM power-down feature that is enabled by the SLP\_S4# Assertion Stretch Enable bit (D31:F0:A4h bit 3), the DRAM power must be controlled by the SLP\_S4# signal.

### 5.13.11.3 PWROK Signal

The PWROK input should go active based on the core supply voltages becoming valid. PWROK should go active no sooner than 100 ms after Vcc3\_3 and Vcc1\_5 have reached their nominal values.

**Note:**

1. SYSRESET# is recommended for implementing the system reset button. This saves external logic that is needed if the PWROK input is used. Additionally, it allows for better handling of the SMBus and processor resets, and avoids improperly reporting power failures.
2. If the PWROK input is used to implement the system reset button, the ICH8 does not provide any mechanism to limit the amount of time that the processor is held in reset. The platform must externally assure that maximum reset assertion specs are met.
3. If a design has an active-low reset button electrically AND'd with the PWROK signal from the power supply and the processor's voltage regulator module the ICH8 PWROK\_FLR bit will be set. The ICH8 treats this internally as if the RSMRST# signal had gone active. However, it is not treated as a full power failure. If PWROK goes inactive and then active (but RSMRST# stays high), then the ICH8 reboots (regardless of the state of the AFTERG3 bit). If the RSMRST# signal also goes low before PWROK goes high, then this is a full power failure, and the reboot policy is controlled by the AFTERG3 bit.
4. PWROK and RSMRST# are sampled using the RTC clock. Therefore, low times that are less than one RTC clock period may not be detected by the ICH8.
5. In the case of true PWROK failure, PWROK goes low first before the VRMPWRGD.
6. When PWROK goes inactive, a host power cycle and global reset will occur. A host power cycle is the assertion of SLP\_S3#, SLP\_S4#, and SLP\_S5#, and the deassertion of these signals 3-5 seconds later. The ME remains powered throughout this cycle.

### 5.13.11.4 CPUPWRGD Signal

This signal is connected to the processor's VRM via the VRMPWRGD signal and is internally AND'd with the PWROK signal that comes from the system power supply.

### 5.13.11.5 VRMPWRGD Signal

VRMPWRGD is an input from the regulator indicating that all of the outputs from the regulator are on and within specification. VRMPWRGD may go active before or after the PWROK from the main power supply. ICH8 has no dependency on the order in which these two signals go active or inactive. However, platforms that use the VRMPWRGD signal to start the clock chip PLLs assume that it does assert milliseconds before PWROK in order to provide valid clocks in time for the PWROK rising.



**Note:** When VRMPWRGD goes inactive, a host power cycle and global reset will occur.

### 5.13.11.6 BATLOW# (Battery Low) (Mobile Only)

The BATLOW# input can inhibit waking from S3, S4, and S5 states if there is not sufficient power. It also causes an SMI# if the system is already in an S0 state.

### 5.13.11.7 Controlling Leakage and Power Consumption during Low-Power States

To control leakage in the system, various signals tri-state or go low during some low-power states.

General principles:

- All signals going to powered down planes (either internally or externally) must be either tri-stated or driven low.
- Signals with pull-up resistors should not be low during low-power states. This is to avoid the power consumed in the pull-up resistor.
- Buses should be halted (and held) in a known state to avoid a floating input (perhaps to some other device). Floating inputs can cause extra power consumption.

Based on the above principles, the following measures are taken:

- During S3 (STR), all signals attached to powered down planes are tri-stated or driven low.

## 5.13.12 Clock Generators

The clock generator is expected to provide the frequencies shown in [Table 76](#).

**Table 76. Intel® ICH8 Clock Inputs**

Clock Domain	Frequency	Source	Usage
SATA_CLK	100 MHz Differential	Main Clock Generator	Used by SATA controller. Stopped in S3 ~ S5 based on SLP_S3# assertion.
DMI_CLK	100 MHz Differential	Main Clock Generator	Used by DMI and PCI Express*. Stopped in S3 ~ S5 based on SLP_S3# assertion.
PCICLK	33 MHz	Main Clock Generator	Desktop: Free-running PCI Clock to ICH8. Stopped in S3 ~ S5 based on SLP_S3# assertion. Mobile: Free-running (not affected by STP_PCI# PCI Clock to ICH8. This is not the system PCI clock. This clock must keep running in S0 while the system PCI clock may stop based on CLKRUN# protocol. Stopped in S3 ~ S5 based on SLP_S3# assertion.
CLK48	48.000 MHz	Main Clock Generator	Used by USB controllers and Intel® High Definition Audio controller. Stopped in S3 ~ S5 based on SLP_S3# assertion.
CLK14	14.318 MHz	Main Clock Generator	Used by ACPI timers. Stopped in S3 ~ S5 based on SLP_S3# assertion.
LAN_CLK	0.8 to 50 MHz	LAN Connect	LAN Connect Interface. Control policy is determined by the clock source.



### 5.13.12.1 Clock Control Signals from Intel® ICH8 to Clock Synthesizer (Mobile Only)

The clock generator is assumed to have direct connect from the following ICH8 signals:

- STP\_CPU#: Stops processor clocks in C3 and C4 states
- STP\_PCI#: Stops system PCI clocks (not the ICH8 free-running 33 MHz clock) due to CLKRUN# protocol
- SLP\_S3#: Expected to drive clock chip PWRDOWN (through inverter), to stop clocks in S3 to S5.

### 5.13.13 Legacy Power Management Theory of Operation

Instead of relying on ACPI software, legacy power management uses BIOS and various hardware mechanisms. The scheme relies on the concept of detecting when individual subsystems are idle, detecting when the whole system is idle, and detecting when accesses are attempted to idle subsystems.

However, the operating system is assumed to be at least APM enabled. Without APM calls, there is no quick way to know when the system is idle between keystrokes. The ICH8 does not support burst modes.

#### 5.13.13.1 APM Power Management (Desktop Only)

The ICH8 has a timer that, when enabled by the 1MIN\_EN bit in the SMI Control and Enable register, generates an SMI# once per minute. The SMI handler can check for system activity by reading the DEVACT\_STS register. If none of the system bits are set, the SMI handler can increment a software counter. When the counter reaches a sufficient number of consecutive minutes with no activity, the SMI handler can then put the system into a lower power state.

If there is activity, various bits in the DEVACT\_STS register will be set. Software clears the bits by writing a 1 to the bit position.

The DEVACT\_STS register allows for monitoring various internal devices, or Super I/O devices (SP, PP, FDC) on LPC or PCI, keyboard controller accesses, or audio functions on LPC or PCI. Other PCI activity can be monitored by checking the PCI interrupts.

#### 5.13.13.2 Mobile APM Power Management (Mobile Only)

In mobile systems, there are additional requirements associated with device power management. To handle this, the ICH8 has specific SMI# traps available. The following algorithm is used:

1. The periodic SMI# timer checks if a device is idle for the require time. If so, it puts the device into a low-power state and sets the associated SMI# trap.
2. When software (not the SMI# handler) attempts to access the device, a trap occurs (the cycle does not really go to the device and an SMI# is generated).
3. The SMI# handler turns on the device and turns off the trap

The SMI# handler exits with an I/O restart. This allows the original software to continue.

## 5.14 System Management (D31:F0)

The ICH8 provides various functions to make a system easier to manage and to lower the Total Cost of Ownership (TCO) of the system. In addition, ICH8 provides integrated ASF Management support. Features and functions can be augmented via external A/D converters and GPIO, as well as an external microcontroller.

The following features and functions are supported by the ICH8:

- Processor present detection
  - Detects if processor fails to fetch the first instruction after reset
- Various Error detection (such as ECC Errors) Indicated by host controller
  - Can generate SMI#, SCI, SERR, NMI, or TCO interrupt
- Intruder Detect input
  - Can generate TCO interrupt or SMI# when the system cover is removed
  - INTRUDER# allowed to go active in any power state, including G3
- Detection of bad BIOS Flash (FWH or Flash on SPI) programming
  - Detects if data on first read is FFh (indicates that BIOS flash is not programmed)
- Ability to hide a PCI device
  - Allows software to hide a PCI device in terms of configuration space through the use of a device hide register (See [Section 7.1.71](#))

**Note:** Voltage ID from the processor can be read via GPI signals.

**Note:** ASF functionality with the integrated ICH8 ASF controller requires a correctly configured system, including an appropriate (G)MCH with ME, ME Firmware, system BIOS support, and appropriate Platform LAN Connect Device.

### 5.14.1 Theory of Operation

The System Management functions are designed to allow the system to diagnose failing subsystems. The intent of this logic is that some of the system management functionality be provided without the aid of an external microcontroller.

#### 5.14.1.1 Detecting a System Lockup

When the processor is reset, it is expected to fetch its first instruction. If the processor fails to fetch the first instruction after reset, the TCO timer times out twice and the ICH8 asserts PLTRST#.

#### 5.14.1.2 Handling an Intruder

The ICH8 has an input signal, INTRUDER#, that can be attached to a switch that is activated by the system's case being open. This input has a two RTC clock debounce. If INTRUDER# goes active (after the debouncer), this will set the INTRD\_DET bit in the TCO\_STS register. The INTRD\_SEL bits in the TCO\_CNT register can enable the ICH8 to cause an SMI# or interrupt. The BIOS or interrupt handler can then cause a transition to the S5 state by writing to the SLP\_EN bit.

The software can also directly read the status of the INTRUDER# signal (high or low) by clearing and then reading the INTRD\_DET bit. This allows the signal to be used as a GPI if the intruder function is not required.





If the INTRUDER# signal goes inactive some point after the INTRD\_DET bit is written as a 1, then the INTRD\_DET signal will go to a 0 when INTRUDER# input signal goes inactive. Note that this is slightly different than a classic sticky bit, since most sticky bits would remain active indefinitely when the signal goes active and would immediately go inactive when a 1 is written to the bit.

**Note:** The INTRD\_DET bit resides in the ICH8's RTC well, and is set and cleared synchronously with the RTC clock. Thus, when software attempts to clear INTRD\_DET (by writing a 1 to the bit location) there may be as much as two RTC clocks (about 65  $\mu$ s) delay before the bit is actually cleared. Also, the INTRUDER# signal should be asserted for a minimum of 1 ms to assure that the INTRD\_DET bit will be set.

**Note:** If the INTRUDER# signal is still active when software attempts to clear the INTRD\_DET bit, the bit remains set and the SMI is generated again immediately. The SMI handler can clear the INTRD\_SEL bits to avoid further SMIs. However, if the INTRUDER# signal goes inactive and then active again, there will not be further SMIs, since the INTRD\_SEL bits would select that no SMI# be generated.

### 5.14.1.3 Detecting Improper Firmware Hub Programming

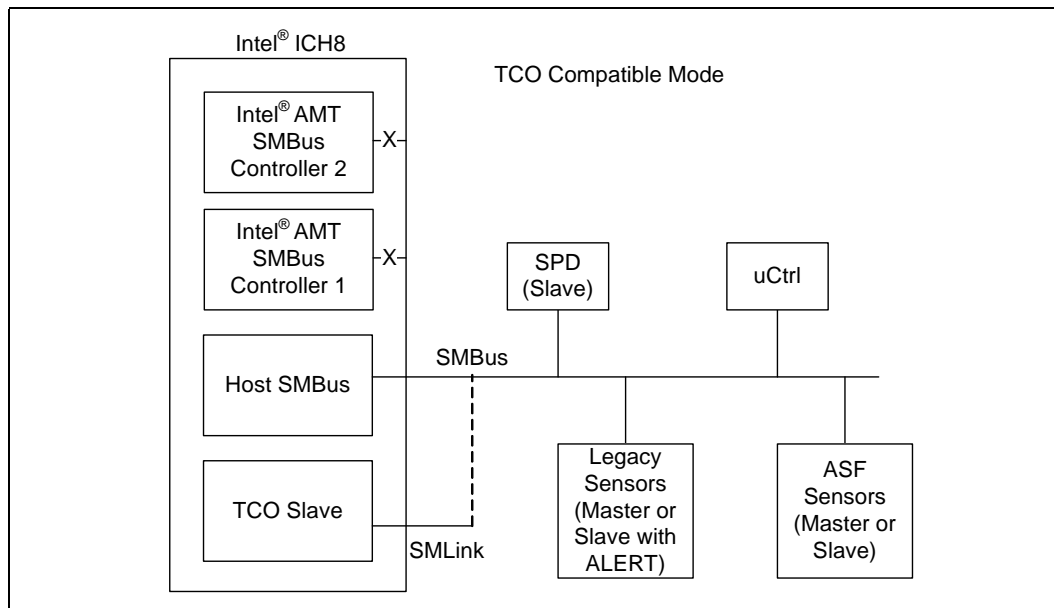
The ICH8 can detect the case where the BIOS flash is not programmed. This results in the first instruction fetched to have a value of FFh. If this occurs, the ICH8 sets the BAD\_BIOS bit. The BIOS flash may reside in FWH or flash on the SPI bus.

## 5.14.2 TCO Modes

### 5.14.2.1 TCO Legacy/Compatible Mode

In TCO Legacy/Compatible mode the Intel Management Engine and Intel AMT logic and SMBus controllers are disabled. To enable Legacy/Compatible TCO mode the TCOMODE bit 7 in the ICHSTRP0 register in the SPI device must be 0. See [Section 20.2.5.1](#) for details.

**Note:** SMBus and SMLink may be tied together externally, if a device has a single SMBus interface and needs access to the TCO slave and be visible to the host SMBus controller.

**Table 77. TCO Legacy/Compatible Mode SMBus Configuration**


In TCO Legacy/Compatible mode the Intel ICH8/ICH8M can function directly with the integrated Gigabit Ethernet controller or equivalent external LAN controller to report messages to a network management console without the aid of the system processor. This is crucial in cases where the processor is malfunctioning or cannot function due to being in a low-power state. Table 78 includes a list of events that will report messages to the network management console.

**Table 78. Event Transitions that Cause Messages**

Event	Assertion?	Deassertion?	Comments
INTRUDER# pin	yes	no	Must be in "S1 or hung S0" state
THRM# pin	yes	yes	Must be in "S1 or hung S0" state. Note that the THRM# pin is isolated when the core power is off, thus preventing this event in S3-S5.
Watchdog Timer Expired	yes	no (NA)	"S1 or hung S0" state entered
GPIO[11]/SMBALERT# pin	yes	yes	Must be in "S1 or hung S0" state
BATLOW#	yes	yes	Must be in "S1 or hung S0" state
CPU_PWR_FLR	yes	no	"S1 or hung S0" state entered

**NOTE:** The GPIO11/SMBALERT# pin will trigger an event message (when enabled by the GPIO11\_ALERT\_DISABLE bit) regardless of whether it is configured as a GPI or not.



### 5.14.2.2 Advanced TCO Mode

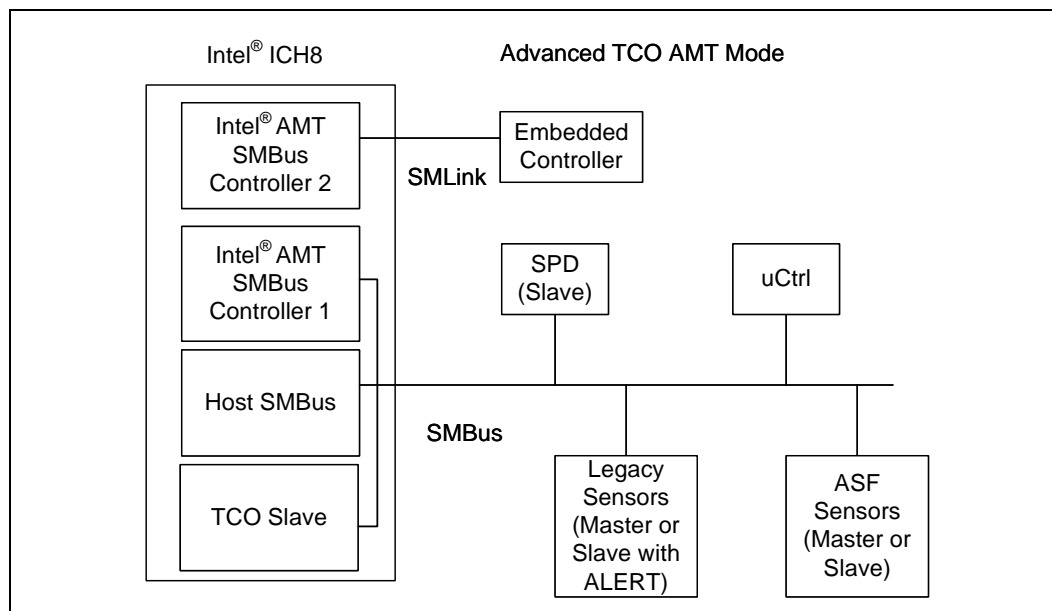
Intel ICH8/ICH8M supports two modes of Advanced TCO. Intel® Active Management Technology mode and BMC mode. To enable Advance TCO mode (AMT or BMC mode) the TCOMODE bit 7 in the ICHSTRP0 register in the SPI device must be 1. See Section 20.2.5.1 for details.

#### Advanced TCO Intel® Active Management Technology mode

In this mode, Intel AMT SMBus Controller 1, Host SMBus and SMLink are connected together internally. See Figure below. This mode is enabled when the BMCMODE bit 15 in the ICHSTRP0 register in the SPI device is 0. See Section 20.2.5.1 for details.

The Intel AMT SMBus Controller 2 can be connected to either the SMBus pins or the SMLink pins by the MESM2SEL bit 23 in the ICHSTRP0 register in the SPI device. See Section 20.2.5.1 for details. The default is to have the Intel AMT SMBus Controller 2 connected to SMLink. The AMT SMBus Controller 2 has no connection to LINKALERT#.

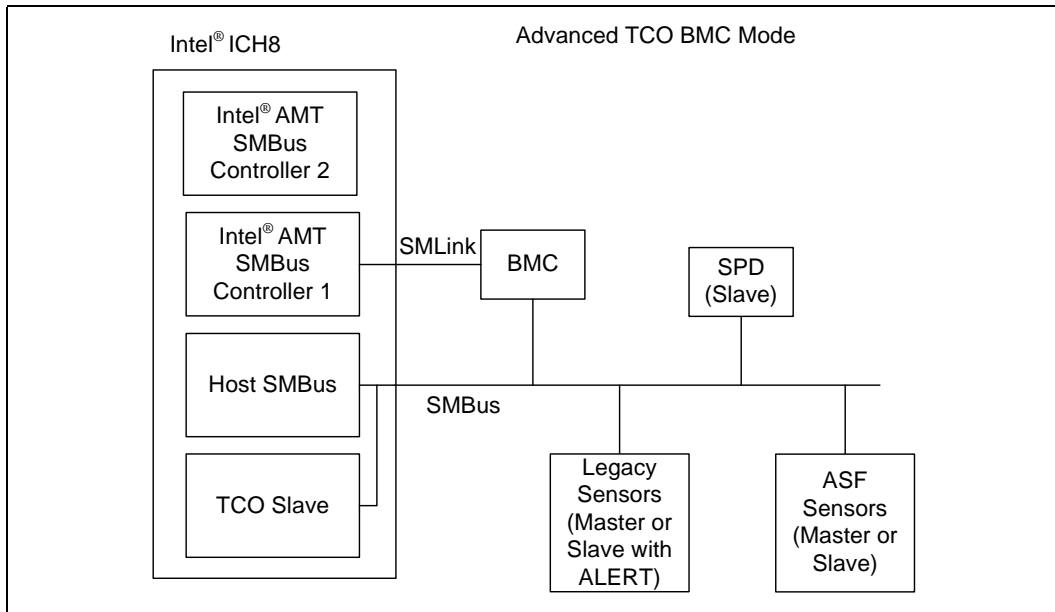
Figure 11. Advanced TCO Intel® AMT Mode SMBus/SMLink Configuration



### 5.14.2.3 Advanced TCO BMC Mode

In this mode, the external microcontroller (BMC) is connected to both SMLink and SMBus. The BMC communicates with Management Engine through AMT SMBus connected to SMLink. The host and TCO slave communicated with BMC through SMBus. See figure below. This mode is enabled when the BMCMODE bit 15 in the ICHSTRP0 register in the SPI device is 1. See Section 20.2.5.1 for details.

Figure 12. Advanced TCO BMC Mode SMBus/SMLink Configuration





## 5.15 IDE Controller (D31:F1) (Mobile Only)

The ICH8 IDE controller features one set of interface signals that can be enabled, tri-stated or driven low.

The IDE interfaces of the ICH8 can support several types of data transfers:

- **Programmed I/O (PIO):** Processor is in control of the data transfer.
- **8237 style DMA:** DMA protocol that resembles the DMA on the ISA bus, although it does not use the 8237 in the ICH8. This protocol off loads the processor from moving data. This allows higher transfer rate of up to 16 MB/s.
- **Ultra ATA/33:** DMA protocol that redefines signals on the IDE cable to allow both host and target throttling of data and transfer rates of up to 33 MB/s.
- **Ultra ATA/66:** DMA protocol that redefines signals on the IDE cable to allow both host and target throttling of data and transfer rates of up to 66 MB/s.
- **Ultra ATA/100:** DMA protocol that redefines signals on the IDE cable to allow both host and target throttling of data and transfer rates of up to 100 MB/s.

### 5.15.1 PIO Transfers

The ICH8 IDE controller includes both compatible and fast timing modes. The fast timing modes can be enabled only for the IDE data ports. All other transactions to the IDE registers are run in single transaction mode with compatible timings.

Up to two IDE devices may be attached to the IDE connector (drive 0 and drive 1). The IDE\_TIMP and IDE\_TIMS Registers permit different timing modes to be programmed for drive 0 and drive 1 of the same connector.

The Ultra ATA/33/66/100 synchronous DMA timing modes can also be applied to each drive by programming the IDE I/O Configuration register and the Synchronous DMA Control and Timing registers. When a drive is enabled for synchronous DMA mode operation, the DMA transfers are executed with the synchronous DMA timings. The PIO transfers are executed using compatible timings or fast timings if also enabled.

#### 5.15.1.1 PIO IDE Timing Modes

IDE data port transaction latency consists of startup latency, cycle latency, and shutdown latency. Startup latency is incurred when a PCI master cycle targeting the IDE data port is decoded and the DA[2:0] and CSxx# lines are not set up. Startup latency provides the setup time for the DA[2:0] and CSxx# lines prior to assertion of the read and write strobes (DIOR# and DIOW#).

Cycle latency consists of the I/O command strobe assertion length and recovery time. Recovery time is provided so that transactions may occur back-to-back on the IDE interface (without incurring startup and shutdown latency) without violating minimum cycle periods for the IDE interface. The command strobe assertion width for the enhanced timing mode is selected by the IDE\_TIM Register and may be set to 2, 3, 4, or 5 PCI clocks. The recovery time is selected by the IDE\_TIM Register and may be set to 1, 2, 3, or 4 PCI clocks.

If IORDY is asserted when the initial sample point is reached, no wait-states are added to the command strobe assertion length. If IORDY is negated when the initial sample point is reached, additional wait-states are added. Since the rising edge of IORDY must be synchronized, at least two additional PCI clocks are added.



Shutdown latency is incurred after outstanding scheduled IDE data port transactions (either a non-empty write post buffer or an outstanding read prefetch cycles) have completed and before other transactions can proceed. It provides hold time on the DA[2:0] and CSxx# lines with respect to the read and write strobes (DIOR# and DIOW#). Shutdown latency is two PCI clocks in duration.

The IDE timings for various transaction types are shown in Table 79.

**Table 79. IDE Transaction Timings (PCI Clocks)**

IDE Transaction Type	Startup Latency	IORDY Sample Point (ISP)	Recovery Time (RCT)	Shutdown Latency
Non-Data Port Compatible	4	11	22	2
Data Port Compatible	3	6	14	2
Fast Timing Mode	2	2–5	1–4	2

#### 5.15.1.2 IORDY Masking

The IORDY signal can be ignored and assumed asserted at the first IORDY Sample Point (ISP) on a drive by drive basis via the IDETIM Register.

#### 5.15.1.3 PIO 32-Bit IDE Data Port Accesses

A 32-bit PCI transaction run to the IDE data address (01F0h primary) results in two back-to-back 16-bit transactions to the IDE data port. The 32-bit data port feature is enabled for all timings, not just enhanced timing. For compatible timings, a shutdown and startup latency is incurred between the two, 16-bit halves of the IDE transaction. This assures that the chip selects are deasserted for at least two PCI clocks between the two cycles.

#### 5.15.1.4 PIO IDE Data Port Prefetching and Posting

The ICH8 can be programmed via the IDETIM registers to allow data to be posted to and prefetched from the IDE data ports.

Data prefetching is initiated when a data port read occurs. The read prefetch eliminates latency to the IDE data ports and allows them to be performed back-to-back for the highest possible PIO data transfer rates. The first data port read of a sector is called the demand read. Subsequent data port reads from the sector are called prefetch reads. The demand read and all prefetch reads must be of the same size (16 or 32 bits) – software must not mix 32-bit and 16-bit reads.

Data posting is performed for writes to the IDE data ports. The transaction is completed on the PCI bus after the data is received by the ICH8. The ICH8 then runs the IDE cycle to transfer the data to the drive. If the ICH8 write buffer is non-empty and an unrelated (non-data or opposite channel) IDE transaction occurs, that transaction will be stalled until all current data in the write buffer is transferred to the drive. Only 16-bit buffer writes are supported.



## 5.15.2 Bus Master Function

The ICH8 can act as a PCI Bus master on behalf of an IDE device. One PCI Bus master channel is provided for the IDE connector. By performing the IDE data transfer as a PCI Bus master, the ICH8 off-loads the processor and improves system performance in multitasking environments. Both devices attached to the connector can be programmed for bus master transfers, but only one device can be active at a time.

### 5.15.2.1 Physical Region Descriptor Format

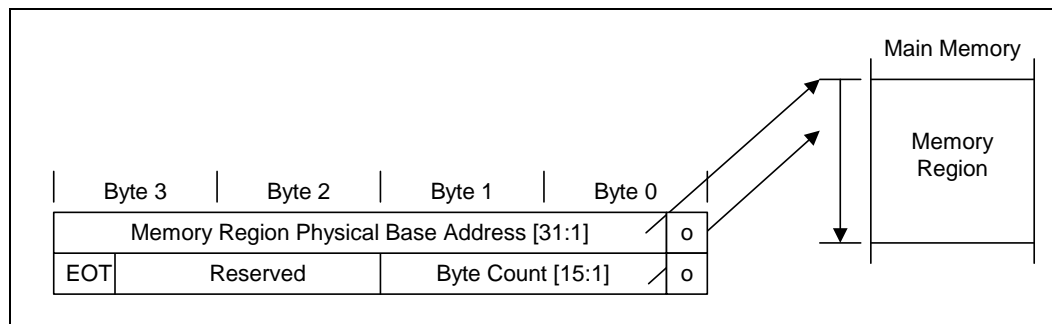
The physical memory region to be transferred is described by a Physical Region Descriptor (PRD). The PRDs are stored sequentially in a Descriptor Table in memory. The data transfer proceeds until all regions described by the PRDs in the table have been transferred.

Descriptor Tables must not cross a 64-KB boundary. Each PRD entry in the table is 8 bytes in length. The first 4 bytes specify the byte address of a physical memory region. This memory region must be dword-aligned and must not cross a 64-KB boundary. The next two bytes specify the size or transfer count of the region in bytes (64-KB limit per region). A value of 0 in these two bytes indicates 64-KB (thus the minimum transfer count is 1). If bit 7 (EOT) of the last byte is a 1, it indicates that this is the final PRD in the Descriptor table. Bus master operation terminates when the last descriptor has been retired.

When the Bus Master IDE controller is reading data from the memory regions, bit 1 of the Base Address is masked and byte enables are asserted for all read transfers. When writing data, bit 1 of the Base Address is not masked and if set, will cause the lower Word byte enables to be deasserted for the first dword transfer. The write to PCI typically consists of a 32-byte cache line. If valid data ends prior to end of the cache line, the byte enables will be deasserted for invalid data.

The total sum of the byte counts in every PRD of the descriptor table must be equal to or greater than the size of the disk transfer request. If greater than the disk transfer request, the driver must terminate the bus master transaction (by setting bit 0 in the Bus Master IDE Command Register to 0) when the drive issues an interrupt to signal transfer completion.

Figure 13. Physical Region Descriptor Table Entry



### 5.15.2.2 Bus Master IDE Timings

The timing modes used for Bus Master IDE transfers are identical to those for PIO transfers. The DMA Timing Enable Only bits in IDE Timing register can be used to program fast timing mode for DMA transactions only. This is useful for IDE devices whose DMA transfer timings are faster than its PIO transfer timings. The IDE device DMA request signal is sampled on the same PCI clock that DIOR# or DIOV# is deasserted. If inactive, the DMA Acknowledge signal is deasserted on the next PCI clock and no more transfers take place until DMA request is asserted again.

### 5.15.2.3 Interrupts

The ICH8 can generate interrupts based upon a signal coming from the PATA device, or due to the completion of a PRD with the 'I' bit set. The interrupt is edge triggered and active high. The PATA host controller generates IDEIRQ.

When the ICH8 IDE controller is operating independently from the SATA controller (D31:F2), IDEIRQ will generate IRQ14. When operating in conjunction with the SATA controller (combined mode), IDE interrupts will still generate IDEIRQ, but this may in turn generate either IRQ14 or IRQ15, depending upon the value of the MAP.MV (D31:F2:90h:bits 1:0) register. When in combined mode and the SATA controller is emulating the logical secondary channel (MAP.MV = 1h), the PATA channel will emulate the logical primary channel and IDEIRQ will generate IRQ14. Conversely, if the SATA controller in combined mode is emulating the logical primary channel (MAP.MV=2h), IDEIRQ will generate IRQ15.

**Note:** IDE interrupts cannot be communicated through PCI devices or the serial IRQ stream.

### 5.15.2.4 Bus Master IDE Operation

To initiate a bus master transfer between memory and an IDE device, the following steps are required:

1. Software prepares a PRD table in system memory. The PRD table must be dword-aligned and must not cross a 64-KB boundary.
2. Software provides the starting address of the PRD Table by loading the PRD Table Pointer Register. The direction of the data transfer is specified by setting the Read/Write Control bit. The interrupt bit and Error bit in the Status register are cleared.
3. Software issues the appropriate DMA transfer command to the disk device.
4. The bus master function is engaged by software writing a 1 to the Start bit in the Command Register. The first entry in the PRD table is fetched and loaded into two registers which are not visible by software, the Current Base and Current Count registers. These registers hold the current value of the address and byte count loaded from the PRD table. The value in these registers is only valid when there is an active command to an IDE device.
5. Once the PRD is loaded internally, the IDE device will receive a DMA acknowledge.
6. The controller transfers data to/from memory responding to DMA requests from the IDE device. The IDE device and the host controller may or may not throttle the transfer several times. When the last data transfer for a region has been completed on the IDE interface, the next descriptor is fetched from the table. The descriptor contents are loaded into the Current Base and Current Count registers.
7. At the end of the transfer, the IDE device signals an interrupt.
8. In response to the interrupt, software resets the Start/Stop bit in the command register. It then reads the controller status followed by the drive status to determine if the transfer completed successfully.





The last PRD in a table has the End of List (EOL) bit set. The PCI bus master data transfers terminate when the physical region described by the last PRD in the table has been completely transferred. The active bit in the Status Register is reset and the DDRQ signal is masked.

The buffer is flushed (when in the write state) or invalidated (when in the read state) when a terminal count condition exists; that is, the current region descriptor has the EOL bit set and that region has been exhausted. The buffer is also flushed (write state) or invalidated (read state) when the Interrupt bit in the Bus Master IDE Status register is set. Software that reads the status register and finds the Error bit reset, and either the Active bit reset or the Interrupt bit set, can be assured that all data destined for system memory has been transferred and that data is valid in system memory. [Table 80](#) describes how to interpret the Interrupt and Active bits in the Status Register after a DMA transfer has started.

**Table 80. Interrupt/Active Bit Interaction Definition**

Interrupt	Active	Description
0	1	DMA transfer is in progress. No interrupt has been generated by the IDE device.
1	0	The IDE device generated an interrupt. The controller exhausted the Physical Region Descriptors. This is the normal completion case where the size of the physical memory regions was equal to the IDE device transfer size.
1	1	The IDE device generated an interrupt. The controller has not reached the end of the physical memory regions. This is a valid completion case where the size of the physical memory regions was larger than the IDE device transfer size.
0	0	This bit combination signals an error condition. If the Error bit in the status register is set, then the controller has some problem transferring data to/from memory. Specifics of the error have to be determined using bus-specific information. If the Error bit is not set, then the PRDs specified a smaller size than the IDE transfer size.

### 5.15.2.5 Error Conditions

IDE devices are sector based mass storage devices. The drivers handle errors on a sector basis; either a sector is transferred successfully or it is not. A sector is 512 bytes.

If the IDE device does not complete the transfer due to a hardware or software error, the command will eventually be stopped by the driver setting Command Start bit to 0 when the driver times out the disk transaction. Information in the IDE device registers help isolate the cause of the problem.

If the controller encounters an error while doing the bus master transfers it will stop the transfer (i.e., reset the Active bit in the Command register) and set the Error bit in the Bus Master IDE Status register. The controller does not generate an interrupt when this happens. The device driver can use device specific information (PCI Configuration Space Status register and IDE Drive Register) to determine what caused the error.

Whenever a requested transfer does not complete properly, information in the IDE device registers (Sector Count) can be used to determine how much of the transfer was completed and to construct a new PRD table to complete the requested operation. In most cases the existing PRD table can be used to complete the operation.



### 5.15.3 Ultra ATA/100/66/33 Protocol

The ICH8 supports Ultra ATA/100/66/33 bus mastering protocol, providing support for a variety of transfer speeds with IDE devices. Ultra ATA/33 provides transfers up to 33 MB/s, Ultra ATA/66 provides transfers at up to 44 MB/s or 66 MB/s, and Ultra ATA/100 can achieve read transfer rates up to 100 MB/s and write transfer rates up to 88.9 MB/s.

The Ultra ATA/100/66/33 definition also incorporates a Cyclic Redundancy Checking (CRC-16) error checking protocol.

#### 5.15.3.1 Operation

Initial setup programming consists of enabling and performing the proper configuration of the ICH8 and the IDE device for Ultra ATA/100/66/33 operation. For the ICH8, this consists of enabling synchronous DMA mode and setting up appropriate Synchronous DMA timings.

When ready to transfer data to or from an IDE device, the Bus Master IDE programming model is followed. Once programmed, the drive and ICH8 control the transfer of data via the Ultra ATA/100/66/33 protocol. The actual data transfer consists of three phases, a start-up phase, a data transfer phase, and a burst termination phase.

The IDE device begins the start-up phase by asserting DMARQ signal. When ready to begin the transfer, the ICH8 asserts DMACK# signal. When DMACK# signal is asserted, the host controller drives CS0# and CS1# inactive, DA0–DA2 low. For write cycles, the ICH8 deasserts STOP, waits for the IDE device to assert DMARDY#, and then drives the first data word and STROBE signal. For read cycles, the ICH8 tri-states the DD lines, deasserts STOP, and asserts DMARDY#. The IDE device then sends the first data word and STROBE.

The data transfer phase continues the burst transfers with the data transmitter (ICH8 – writes, IDE device – reads) providing data and toggling STROBE. Data is transferred (latched by receiver) on each rising and falling edge of STROBE. The transmitter can pause the burst by holding STROBE high or low, resuming the burst by again toggling STROBE. The receiver can pause the burst by deasserting DMARDY# and resumes the transfers by asserting DMARDY#. The ICH8 pauses a burst transaction to prevent an internal line buffer over or under flow condition, resuming once the condition has cleared. It may also pause a transaction if the current PRD byte count has expired, resuming once it has fetched the next PRD.

The current burst can be terminated by either the transmitter or receiver. A burst termination consists of a Stop Request, Stop Acknowledge and transfer of CRC data. The ICH8 can stop a burst by asserting STOP, with the IDE device acknowledging by deasserting DMARQ. The IDE device stops a burst by deasserting DMARQ and the ICH8 acknowledges by asserting STOP. The transmitter then drives the STROBE signal to a high level. The ICH8 then drives the CRC value onto the DD lines and deassert DMACK#. The IDE device latches the CRC value on rising edge of DMACK#. The ICH8 terminates a burst transfer if it needs to service the opposite IDE channel, if a Programmed I/O (PIO) cycle is executed to the IDE channel currently running the burst, or upon transferring the last data from the final PRD.



#### 5.15.4 Ultra ATA/33/66/100 Timing

The timings for Ultra ATA/33/66/100 modes are programmed via the Synchronous DMA Timing register and the IDE Configuration register. Different timings can be programmed for each drive in the system. The Base Clock frequency for each drive is selected in the IDE Configuration register. The Cycle Time (CT) and Ready to Pause (RP) time (defined as multiples of the Base Clock) are programmed in the Synchronous DMA Timing Register. The Cycle Time represents the minimum pulse width of the data strobe (STROBE) signal. The Ready to Pause time represents the number of Base Clock periods that the ICH8 waits from deassertion of DMARDY# to the assertion of STOP when it desires to stop a burst read transaction.

**Note:** The internal Base Clock for Ultra ATA/100 (Mode 5) runs at 133 MHz, and the Cycle Time (CT) must be set for three Base Clocks. The ICH8 thus toggles the write strobe signal every 22.5 ns, transferring two bytes of data on each strobe edge. This means that the ICH8 performs Mode 5 write transfers at a maximum rate of 88.9 MB/s. For read transfers, the read strobe is driven by the ATA/100 device, and the ICH8 supports reads at the maximum rate of 100 MB/s.

#### 5.15.5 ATA Swap Bay

To support PATA swap bay, the ICH8 allows the IDE output signals to be tri-stated and input buffers to be turned off. This should be done prior to the removal of the drive. The output signals can also be driven low. This can be used to remove charge built up on the signals. Configuration bits are included in the IDE I/O Configuration register, offset 54h in the IDE PCI configuration space.

In a PATA swap bay operation, an IDE device is removed and a new one inserted while the IDE interface is powered down and the rest of the system is in a fully powered-on state (SO). During a PATA swap bay operation, if the operating system executes cycles to the IDE interface after it has been powered down it will cause the ICH8 to hang the system that is waiting for IORDY to be asserted from the drive.

To correct this issue, the following BIOS procedures are required for performing an IDE swap:

1. Program IDE SIG\_MODE (Configuration register at offset 54h) to 10b (drive low mode).
2. Clear IORDY Sample Point Enable (bits 1 or 5 of IDE Timing reg.). This prevents the ICH8 from waiting for IORDY assertion when the operating system accesses the IDE device after the IDE drive powers down, and ensures that 0s are always be returned for read cycles that occur during swap operation.

**Warning:** Software should **not** attempt to control the outputs (either tri-state or driving low), while an IDE transfer is in progress. Unpredictable results could occur, including a system lockup.

#### 5.15.6 SMI Trapping

Device 31:Function 1: Offset C0h (see [Section 12.1.56](#)) contain control for generating SMI# on accesses to the IDE I/O spaces. These bits map to the legacy ranges (1F0–1F7h and 3F6h). Accesses to one of these ranges with the appropriate bit set causes the cycle to not be forwarded to the IDE controller, and for an SMI# to be generated. If an access to the Bus-Master IDE registers occurs while trapping is enabled for the device being accessed, then the register is updated, an SMI# is generated, and the device activity status bits (Device 31:Function 1:Offset C4h) are updated indicating that a trap occurred.



## 5.16 SATA Host Controller (D31:F2, F5)

The SATA function in the ICH8 has three modes of operation to support different operating system conditions. In the case of Native IDE enabled operating systems, the ICH8 utilizes two controllers to enable all six ports of the bus. The first controller (Device 31: Function 2) supports ports 0 -3 and the second controller (Device 31: Function 5) supports ports 4 and 5. When using a legacy operating system, only one controller (Device 31: Function 2) is available that supports ports 0 – 3. In AHCI or RAID mode, only one controller (Device 31: Function 2) is utilized enabling all six ports.

The MAP register, [Section 13.1.29](#), provides the ability to share PCI functions. When sharing is enabled, all decode of I/O is done through the SATA registers. Device 31, Function 1 (IDE controller) is hidden by software writing to the Function Disable Register (D31, F0, offset F2h, bit 1), and its configuration registers are not used.

The ICH8 SATA controllers feature six (desktop only) / three (mobile only) sets of interface signals (ports) that can be independently enabled or disabled (they cannot be tri-stated or driven low). Each interface is supported by an independent DMA controller.

The ICH8 SATA controllers interact with an attached mass storage device through a register interface that is equivalent to that presented by a traditional IDE host adapter. The host software follows existing standards and conventions when accessing the register interface and follows standard command protocol conventions.

**Note:** SATA interface transfer rates are independent of UDMA mode settings. SATA interface transfer rates will operate at the bus's maximum speed, regardless of the UDMA mode reported by the SATA device or the system BIOS.

**Table 81. SATA Feature Support**

Feature	ICH8 (AHCI/ RAID Disabled)	ICH8 (AHCI/ RAID Enabled)
Native Command Queuing (NCQ)	N/A	Supported
Auto Activate for DMA	N/A	Supported
Hot Plug Support	N/A	Supported
Asynchronous Signal Recovery	N/A	Supported
3 Gb/s Transfer Rate	Supported	Supported
ATAPI Asynchronous Notification	N/A	Supported
Host Initiated Power Management	N/A	Supported (Mobile Only)
Staggered Spin-Up	Supported	Supported
Command Completion Coalescing	N/A	N/A
Port Multiplier	N/A	N/A
External SATA	N/A	Supported (Desktop Only)



Table 82. SATA Feature Support

Feature	Description
Native Command Queuing (NCQ)	Allows the device to reorder commands for more efficient data transfers
Auto Activate for DMA	Collapses a DMA Setup then DMA Activate sequence into a DMA Setup only
Hot Plug Support	Allows for device detection without power being applied and ability to connect and disconnect devices without prior notification to the system
Asynchronous Signal Recovery	Provides a recovery from a loss of signal or establishing communication after hot plug
3 Gb/s Transfer Rate	Capable of data transfers up to 3Gb/s
ATAPI Asynchronous Notification	A mechanism for a device to send a notification to the host that the device requires attention
Host Initiated Power Management	Capability for the host controller to request Partial and Slumber interface power states
Staggered Spin-Up	Enables the host the ability to spin up hard drives sequentially to prevent power load problems on boot
Command Completion Coalescing	Reduces interrupt and completion overhead by allowing a specified number of commands to complete and then generating an interrupt to process the commands
Port Multiplier	A mechanism for one active host connection to communicate with multiple devices
External SATA	Technology that allows for an outside the box connection of up to 2 meters (when using the cable defined in SATA-IO)

## 5.16.1 Theory of Operation

### 5.16.1.1 Standard ATA Emulation

The ICH8 contains a set of registers that shadow the contents of the legacy IDE registers. The behavior of the Command and Control Block registers, PIO, and DMA data transfers, resets, and interrupts are all emulated.

**Note:** The ICHn will assert INTR when the master device completes the EDD command regardless of the command completion status of the slave device. If the master completes EDD first, an INTR is generated and BSY will remain '1' until the slave completes the command. If the slave completes EDD first, BSY will be '0' when the master completes the EDD command and asserts INTR. Software must wait for busy to clear (0) before completing an EDD command, as required by the ATA5 through ATA7 (T13) industry standards.

### 5.16.1.2 48-Bit LBA Operation

The SATA host controller supports 48-bit LBA through the host-to-device register FIS when accesses are performed via writes to the task file. The SATA host controller will ensure that the correct data is put into the correct byte of the host-to-device FIS.



There are special considerations when reading from the task file to support 48-bit LBA operation. Software may need to read all 16-bits. Since the registers are only 8-bits wide and act as a FIFO, a bit must be set in the device/control register, which is at offset 3F6h for primary and 376h for secondary (or their native counterparts).

If software clears bit 7 of the control register before performing a read, the last item written will be returned from the FIFO. If software sets bit 7 of the control register before performing a read, the first item written will be returned from the FIFO.

### 5.16.2 SATA Swap Bay Support

Dynamic Hot-Plug (e.g., surprise removal) is not supported by the SATA host controller without special support from AHCI and the proper board hardware. However, the ICH8 does provide for basic SATA swap bay support using the PSC register configuration bits and power management flows. A device can be powered down by software and the port can then be disabled, allowing removal and insertion of a new device.

**Note:** This SATA swap bay operation requires board hardware (implementation specific), BIOS, and operating system support.

### 5.16.3 Intel® Matrix Storage Technology Configuration (Intel® ICH8R, ICH8DH, ICH8DO, and ICH8M-E Only)

The Intel® Matrix Storage Technology offers several diverse options for RAID (redundant array of independent disks) to meet the needs of the end user. AHCI support provides higher performance and alleviates disk bottlenecks by taking advantage of the independent DMA engines that each SATA port offers in ICH8.

- RAID Level 0 performance scaling up to 4 drives, enabling higher throughput for data intensive applications such as video editing.
- Data security is offered through RAID Level 1, which performs mirroring.
- RAID Level 10 provides high levels of storage performance with data protection, combining the fault-tolerance of RAID Level 1 with the performance of RAID Level 0. By striping RAID Level 1 segments, high I/O rates can be achieved on systems that require both performance and fault-tolerance. RAID Level 10 requires 4 hard drives, and provides the capacity of two drives.
- RAID Level 5 provides highly efficient storage while maintaining fault-tolerance on 3 or more drives. By striping parity, and rotating it across all disks, fault tolerance of any single drive is achieved while only consuming 1 drive worth of capacity. That is, a 3 drive RAID 5 has the capacity of 2 drives, or a 4 drive RAID 5 has the capacity of 3 drives. RAID 5 has high read transaction rates, with a medium write rate. RAID 5 is well suited for applications that require high amounts of storage while maintaining fault tolerance.

By using the ICH8's built-in Intel Matrix Storage Technology, there is no loss of PCI resources (request/grant pair) or add-in card slot.

Intel® Matrix Storage Technology functionality requires the following items:

1. ICH8 component enabled for Intel Matrix Storage Technology (see [Section 1.2](#))
2. Intel® Matrix Storage Manager RAID Option ROM must be on the platform
3. Intel® Matrix Storage Manager drivers, most recent revision.
4. At least two SATA hard disk drives (minimum depends on RAID configuration).

Intel Matrix Storage Technology is not available in the following configurations:

1. The SATA controller in compatible mode.



### 5.16.3.1 Intel® Matrix Storage Manager RAID Option ROM

The Intel Matrix Storage Manager RAID Option ROM is a standard PnP Option ROM that is easily integrated into any System BIOS. When in place, it provides the following three primary functions:

- Provides a text mode user interface that allows the user to manage the RAID configuration on the system in a pre-operating system environment. Its feature set is kept simple to keep size to a minimum, but allows the user to create & delete RAID volumes and select recovery options when problems occur.
- Provides boot support when using a RAID volume as a boot disk. It does this by providing Int13 services when a RAID volume needs to be accessed by DOS applications (such as NTLDR) and by exporting the RAID volumes to the System BIOS for selection in the boot order.
- At each boot up, provides the user with a status of the RAID volumes and the option to enter the user interface by pressing CTRL-I.

## 5.16.4 Power Management Operation

Power management of the ICH8 SATA controller and ports will cover operations of the host controller and the SATA wire.

### 5.16.4.1 Power State Mappings

The D0 PCI power management state for device is supported by the ICH8 SATA controller.

SATA devices may also have multiple power states. From parallel ATA, three device states are supported through ACPI. They are:

- D0 – Device is working and instantly available.
- D1 – device enters when it receives a STANDBY IMMEDIATE command. Exit latency from this state is in seconds
- D3 – from the SATA device's perspective, no different than a D1 state, in that it is entered via the STANDBY IMMEDIATE command. However, an ACPI method is also called which will reset the device and then cut its power.

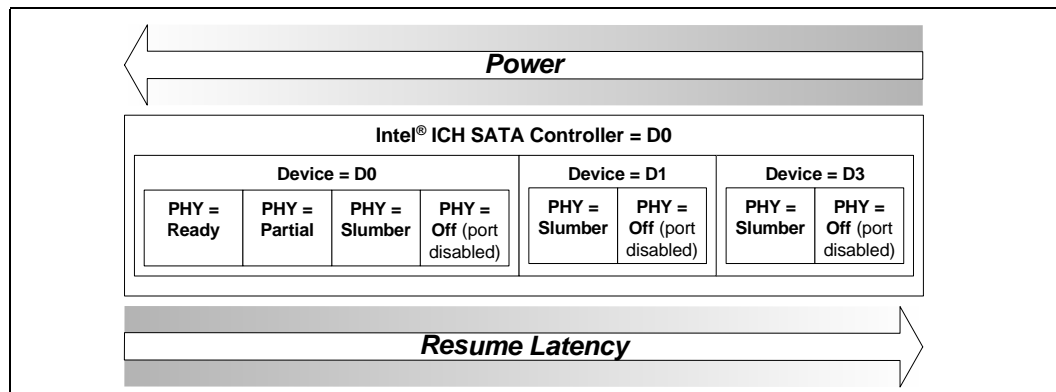
Each of these device states are subsets of the host controller's D0 state.

Finally, SATA defines three PHY layer power states, which have no equivalent mappings to parallel ATA. They are:

- PHY READY – PHY logic and PLL are both on and active
- Partial – PHY logic is powered, but in a reduced state. Exit latency is no longer than 10 ns
- Slumber – PHY logic is powered, but in a reduced state. Exit latency can be up to 10 ms.

Since these states have much lower exit latency than the ACPI D1 and D3 states, the SATA controller defines these states as sub-states of the device D0 state.

Figure 14. SATA Power States



### 5.16.4.2 Power State Transitions

#### 5.16.4.2.1 Partial and Slumber State Entry/Exit

The partial and slumber states save interface power when the interface is idle. It would be most analogous to PCI CLKRUN# (in power savings, not in mechanism), where the interface can have power saved while no commands are pending. The SATA controller defines PHY layer power management (as performed via primitives) as a driver operation from the host side, and a device proprietary mechanism on the device side. The SATA controller accepts device transition types, but does not issue any transitions as a host. All received requests from a SATA device will be ACKed.

When an operation is performed to the SATA controller such that it needs to use the SATA cable, the controller must check whether the link is in the Partial or Slumber states, and if so, must issue a COM\_WAKE to bring the link back online. Similarly, the SATA device must perform the same action.

#### 5.16.4.2.2 Device D1, D3 States

These states are entered after some period of time when software has determined that no commands will be sent to this device for some time. The mechanism for putting a device in these states does not involve any work on the host controller, other than sending commands over the interface to the device. The command most likely to be used in ATA/ATAPI is the "STANDBY IMMEDIATE" command.

#### 5.16.4.2.3 Host Controller D3<sub>HOT</sub> State

After the interface and device have been put into a low power state, the SATA host controller may be put into a low power state. This is performed via the PCI power management registers in configuration space. There are two very important aspects to note when using PCI power management.

1. When the power state is D3, only accesses to configuration space are allowed. Any attempt to access the memory or I/O spaces will result in master abort.
2. When the power state is D3, no interrupts may be generated, even if they are enabled. If an interrupt status bit is pending when the controller transitions to D0, an interrupt may be generated.

When the controller is put into D3, it is assumed that software has properly shut down the device and disabled the ports. Therefore, there is no need to sustain any values on the port wires. The interface will be treated as if no device is present on the cable, and power will be minimized.

When returning from a D3 state, an internal reset will not be performed.





#### 5.16.4.2.4 Non-AHCI Mode PME# Generation

When in non-AHCI mode (legacy mode) of operation, the SATA controller does not generate PME#. This includes attach events (since the port must be disabled), or interlock switch events (via the SATAGP pins).

#### 5.16.4.3 SMI Trapping (APM)

Device 31:Function2:Offset C0h (see [Section 12.1.56](#)) contain control for generating SMI# on accesses to the IDE I/O spaces. These bits map to the legacy ranges (1F0–1F7h, 3F6h, 170–177h, and 376h). If the SATA controller is in legacy mode and is using these addresses, accesses to one of these ranges with the appropriate bit set causes the cycle to not be forwarded to the SATA controller, and for an SMI# to be generated. If an access to the Bus-Master IDE registers occurs while trapping is enabled for the device being accessed, then the register is updated, an SMI# is generated, and the device activity status bits ([Section 12.1.56](#)) are updated indicating that a trap occurred.

#### 5.16.5 SATA LED

The SATALED# output is driven whenever the BSY bit is set in any SATA port. The SATALED# is an active-low open-collector output. When SATALED# is low, the LED should be active. When SATALED# is high, the LED should be inactive.

#### 5.16.6 AHCI Operation

The ICH8 provides hardware support for Advanced Host Controller Interface (AHCI), a programming interface for SATA host controllers developed through a joint industry effort. AHCI defines transactions between the SATA controller and software and enables advanced performance and usability with SATA. Platforms supporting AHCI may take advantage of performance features such as no master/slave designation for SATA devices—each device is treated as a master—and hardware assisted native command queuing. AHCI also provides usability enhancements such as Hot-Plug. AHCI requires appropriate software support (e.g., an AHCI driver) and for some features, hardware support in the SATA device or additional platform hardware.

The ICH8 supports all of the mandatory features of the *Serial ATA Advanced Host Controller Interface Specification*, Revision 1.0 and many optional features, such as hardware assisted native command queuing, aggressive power management, LED indicator support, and Hot-Plug through the use of interlock switch support (additional platform hardware and software may be required depending upon the implementation).

**Note:** For reliable device removal notification while in AHCI operation without the use of interlock switches (surprise removal), interface power management should be disabled for the associated port. See Section 7.3.1 of the *AHCI Specification* for more information.

### 5.16.7 Serial ATA Reference Clock Low Power Request (SATACLKREQ#)

The 100 MHz Serial ATA Reference Clock (SATACLKP, SATACLKN) is implemented on the system as a ground-terminated low-voltage differential signal pair driven by the system Clock Chip. When all the SATA links are in Slumber or disabled, the SATA Reference Clock is not needed and may be stopped and tri-stated at the clock chip allowing system-level power reductions.

The ICH8 uses the SATACLKREQ# output signal to communicate with the system Clock Chip to request either SATA clock running or to tell the system clock chip that it can stop the SATA Reference Clock. ICH8 drives this signal low to request clock running, and tristates the signal to indicate that the SATA Reference Clock may be stopped (the ICH8 never drives the pin high). When the SATACLKREQ# is tristated by the ICH8, the clock chip may stop the SATA Reference Clock within 100 ns, anytime after 100 ns, or not at all. If the SATA Reference Clock is not already running, it will start within 100 ns after a SATACLKREQ# is driven low by the ICH8.

To enable SATA Reference Clock Low Power Request:

1. Configure GPIO35 to native function
2. Set SATA Clock Request Enable (SCRE) bit to '1' (Dev 31:F2:Offset 94h:bit 28).

**Note:** The reset default for SATACLKREQ# is low to ensure that the SATA Reference Clock is running after system reset.

### 5.16.8 SGPIO Signals

The SGPIO signals, in accordance to the SFF-8485 specification, support per-port LED signaling. These signals are not related to SATALED#, which allows for simplified indication of SATA command activity. The SGPIO group interfaces with an external controller chip that fetches and serializes the data for driving across the SGPIO bus. The output signals then control the LEDs.

### 5.16.9 External SATA (Intel® ICH8R, ICH8DH, and ICH8DO Only)

ICH8 supports external SATA. External SATA uses the SATA interface outside of the system box. The usage model for this feature must comply with the Serial ATA II Cables and Connectors Volume 2 Gold specification at [www.sata-io.org](http://www.sata-io.org). Intel validates two configurations:

1. The "cable-up" solution involves an internal SATA cable that connects to the SATA motherboard connector and spans to a back panel PCI bracket with an e-SATA connector. A separate e-SATA cable is required to connect an e-SATA device.
2. The back-panel solution involves running a trace to the I/O back panel and connecting a device via an external SATA connector on the board.

**Note:** Port multipliers are not supported on ICH8. There is no hot plugging of the OS host device. Intel® Matrix Storage Technology must be present to support external SATA.



## 5.17 High Precision Event Timers

This function provides a set of timers that can be used by the operating system. The timers are defined such that in the future, the operating system may be able to assign specific timers to used directly by specific applications. Each timer can be configured to cause a separate interrupt.

ICH8 provides three timers. The three timers are implemented as a single counter each with its own comparator and value register. This counter increases monotonically. Each individual timer can generate an interrupt when the value in its value register matches the value in the main counter.

The registers associated with these timers are mapped to a memory space (much like the I/O APIC). However, it is not implemented as a standard PCI function. The BIOS reports to the operating system the location of the register space. The hardware can support an assignable decode space; however, the BIOS sets this space prior to handing it over to the operating system (See [Section 6.4](#)). It is not expected that the operating system will move the location of these timers once it is set by the BIOS.

### 5.17.1 Timer Accuracy

1. The timers are accurate over any 1 ms period to within 0.05% of the time specified in the timer resolution fields.
2. Within any 100 microsecond period, the timer reports a time that is up to two ticks too early or too late. Each tick is less than or equal to 100 ns, so this represents an error of less than 0.2%.
3. The timer is monotonic. It does not return the same value on two consecutive reads (unless the counter has rolled over and reached the same value).

The main counter is clocked by the 14.31818 MHz clock, synchronized into the 66.666 MHz domain. This results in a non-uniform duty cycle on the synchronized clock, but does have the correct average period. The accuracy of the main counter is as accurate as the 14.3818 MHz clock.

### 5.17.2 Interrupt Mapping

#### Mapping Option #1 (Legacy Replacement Option)

In this case, the Legacy Replacement Rout bit (LEG\_RT\_CNF) is set. This forces the mapping found in [Table 83](#).

**Table 83. Legacy Replacement Routing**

Timer	8259 Mapping	APIC Mapping	Comment
0	IRQ0	IRQ2	In this case, the 8254 timer will not cause any interrupts
1	IRQ8	IRQ8	In this case, the RTC will not cause any interrupts.
2	Per IRQ Routing Field.	Per IRQ Routing Field	

#### Mapping Option #2 (Standard Option)

In this case, the Legacy Replacement Rout bit (LEG\_RT\_CNF) is 0. Each timer has its own routing control. The supported interrupt values are IRQ 20, 21, 22, and 23.



### 5.17.3 Periodic vs. Non-Periodic Modes

#### Non-Periodic Mode

Timer 0 is configurable to 32 (default) or 64-bit mode, whereas Timers 1 and 2 only support 32-bit mode (See [Section 19.1.5](#)).

All three timers support non-periodic mode.

Consult Section 2.3.9.2.1 of the IA-PC HPET Specification for a description of this mode.

#### Periodic Mode

Timer 0 is the only timer that supports periodic mode. Consult Section 2.3.9.2.2 of the *IA-PC HPET Specification* for a description of this mode.

The following usage model is expected:

1. Software clears the ENABLE\_CNF bit to prevent any interrupts
2. Software Clears the main counter by writing a value of 00h to it.
3. Software sets the TIMERO\_VAL\_SET\_CNF bit.
4. Software writes the new value in the TIMERO\_COMPARATOR\_VAL register
5. Software sets the ENABLE\_CNF bit to enable interrupts.

The Timer 0 Comparator Value register cannot be programmed reliably by a single 64-bit write in a 32-bit environment except if only the periodic rate is being changed during run-time. If the actual Timer 0 Comparator Value needs to be reinitialized, then the following software solution will always work regardless of the environment:

1. Set TIMERO\_VAL\_SET\_CNF bit
2. Set the lower 32 bits of the Timer0 Comparator Value register
3. Set TIMERO\_VAL\_SET\_CNF bit
4. 4) Set the upper 32 bits of the Timer0 Comparator Value register

### 5.17.4 Enabling the Timers

The BIOS or operating system PnP code should route the interrupts. This includes the Legacy Rout bit, Interrupt Rout bit (for each timer), interrupt type (to select the edge or level type for each timer)

The Device Driver code should do the following for an available timer:

1. Set the Overall Enable bit (Offset 04h, bit 0).
2. Set the timer type field (selects one-shot or periodic).
3. Set the interrupt enable
4. Set the comparator value



### 5.17.5 Interrupt Levels

Interrupts directed to the internal 8259s are active high. See [Section 5.9](#) for information regarding the polarity programming of the I/O APIC for detecting internal interrupts.

If the interrupts are mapped to the I/O APIC and set for level-triggered mode, they can be shared with PCI interrupts. This may be shared although it's unlikely for the operating system to attempt to do this.

If more than one timer is configured to share the same IRQ (using the `TIMERn_INT_ROUT_CNF` fields), then the software must configure the timers to level-triggered mode. Edge-triggered interrupts cannot be shared.

### 5.17.6 Handling Interrupts

If each timer has a unique interrupt and the timer has been configured for edge-triggered mode, then there are no specific steps required. No read is required to process the interrupt.

If a timer has been configured to level-triggered mode, then its interrupt must be cleared by the software. This is done by reading the interrupt status register and writing a 1 back to the bit position for the interrupt to be cleared.

Independent of the mode, software can read the value in the main counter to see how time has passed between when the interrupt was generated and when it was first serviced.

If Timer 0 is set up to generate a periodic interrupt, the software can check to see how much time remains until the next interrupt by checking the timer value register.

### 5.17.7 Issues Related to 64-Bit Timers with 32-Bit Processors

A 32-bit timer can be read directly using processors that are capable of 32-bit or 64-bit instructions. However, a 32-bit processor may not be able to directly read 64-bit timer. A race condition comes up if a 32-bit processor reads the 64-bit register using two separate 32-bit reads. The danger is that just after reading one half, the other half rolls over and changes the first half.

If a 32-bit processor needs to access a 64-bit timer, it must first halt the timer before reading both the upper and lower 32-bits of the timer. If a 32-bit processor does not want to halt the timer, it can use the 64-bit timer as a 32-bit timer by setting the `TIMERn_32MODE_CNF` bit. This causes the timer to behave as a 32-bit timer. The upper 32-bits are always 0.

## 5.18 USB UHCI Host Controllers (D29:F0, F1, F2 and D26:F0, F1)

The ICH8 contains five USB full/low-speed host controllers that support the standard Universal Host Controller Interface (UHCI), Revision 1.1. Each UHCI Host Controller (UHC) includes a root hub with two separate USB ports each, for a total of ten USB ports.

- Overcurrent detection on all ten USB ports is supported. The overcurrent inputs are not 5 V tolerant, and can be used as GPIOs if not needed.
- The ICH8's UHCI host controllers are arbitrated differently than standard PCI devices to improve arbitration latency.
- The UHCI controllers use the Analog Front End (AFE) embedded cell that allows support for USB full-speed signaling rates, instead of USB I/O buffers.

### 5.18.1 Data Structures in Main Memory

Section 3.1 - 3.3 of the *Universal Host Controller Interface Specification, Revision 1.1* details the data structures used to communicate control, status, and data between software and the ICH8.

### 5.18.2 Data Transfers to/from Main Memory

Section 3.4 of the *Universal Host Controller Interface Specification, Revision 1.1* describes the details on how HCD and the ICH8 communicate via the Schedule data structures.

### 5.18.3 Data Encoding and Bit Stuffing

The ICH8 USB employs NRZI data encoding (Non-Return to Zero Inverted) when transmitting packets. Full details on this implementation are given in the *Universal Serial Bus Specification, Revision 2.0*.

### 5.18.4 Bus Protocol

#### 5.18.4.1 Bit Ordering

Bits are sent out onto the bus least significant bit (LSb) first, followed by next LSb, through to the most significant bit (MSb) last.

#### 5.18.4.2 SYNC Field

All packets begin with a synchronization (SYNC) field, which is a coded sequence that generates a maximum edge transition density. The SYNC field appears on the bus as IDLE followed by the binary string "KJKJKJKK," in its NRZI encoding. It is used by the input circuitry to align incoming data with the local clock and is defined to be 8 bits in length. SYNC serves only as a synchronization mechanism. Full details are given in the *Universal Serial Bus Specification, Revision 2.0*, in Section 8.3.1. The last two bits in the SYNC field are a marker that is used to identify the first bit of the PID. All subsequent bits in the packet must be indexed from this point.

#### 5.18.4.3 Packet Field Formats

All packets have distinct start and end of packet delimiters. Full details are given in the *Universal Serial Bus Specification, Revision 2.0*, in Section 8.3.1.



#### 5.18.4.4 Address Fields

Function endpoints are addressed using the function address field and the endpoint field. Full details on this are given in the *Universal Serial Bus Specification, Revision 2.0*, in Section 8.3.2.

#### 5.18.4.5 Frame Number Field

The frame number field is an 11-bit field that is incremented by the host on a per frame basis. The frame number field rolls over upon reaching its maximum value of 7FFh, and is sent only for SOF tokens at the start of each frame.

#### 5.18.4.6 Data Field

The data field may range from 0 to 1023 bytes and must be an integral numbers of bytes. Data bits within each byte are shifted out LSB first.

#### 5.18.4.7 Cyclic Redundancy Check (CRC)

CRC is used to protect the all non-PID fields in token and data packets. In this context, these fields are considered to be protected fields. Full details on this are given in the *Universal Serial Bus Specification, Revision 2.0*, in Section 8.3.5.

### 5.18.5 Packet Formats

The USB protocol calls out several packet types: token, data, and handshake packets. Full details on this are given in the *Universal Serial Bus Specification, Revision 2.0*, in section 8.4.

### 5.18.6 USB Interrupts

There are two general groups of USB interrupt sources, those resulting from execution of transactions in the schedule, and those resulting from an ICH8 operation error. All transaction-based sources can be masked by software through the ICH8's Interrupt Enable register. Additionally, individual transfer descriptors can be marked to generate an interrupt on completion.

When the ICH8 drives an interrupt for USB, it internally drives the PIRQA# pin for USB function #0 and USB function #3, PIRQD# pin for USB function #1, and the PIRQC# pin for USB function #2, until all sources of the interrupt are cleared. In order to accommodate some operating systems, the Interrupt Pin register must contain a different value for each function of this new multi-function device.

#### 5.18.6.1 Transaction-Based Interrupts

These interrupts are not signaled until after the status for the last complete transaction in the frame has been written back to host memory. This assures that software can safely process through (Frame List Current Index -1) when it is servicing an interrupt.

#### CRC Error / Time-Out

A CRC/Time-Out error occurs when a packet transmitted from the ICH8 to a USB device or a packet transmitted from a USB device to the ICH8 generates a CRC error. The ICH8 is informed of this event by a time-out from the USB device or by the ICH8's CRC checker generating an error on reception of the packet. Additionally, a USB bus time-out occurs when USB devices do not respond to a transaction phase within 19-bit times of an EOP. Either of these conditions causes the C\_ERR field of the TD to decrement.



When the C\_ERR field decrements to 0, the following occurs:

- The Active bit in the TD is cleared
- The Stalled bit in the TD is set
- The CRC/Time-out bit in the TD is set.
- At the end of the frame, the USB Error Interrupt bit is set in the HC status register.

If the CRC/Time out interrupt is enabled in the Interrupt Enable register, a hardware interrupt will be signaled to the system.

### Interrupt on Completion

Transfer Descriptors contain a bit that can be set to cause an interrupt on their completion. The completion of the transaction associated with that block causes the USB Interrupt bit in the HC Status Register to be set at the end of the frame in which the transfer completed. When a TD is encountered with the IOC bit set to 1, the IOC bit in the HC Status register is set to 1 at the end of the frame if the active bit in the TD is set to 0 (even if it was set to 0 when initially read).

If the IOC Enable bit of Interrupt Enable register (bit 2 of I/O offset 04h) is set, a hardware interrupt is signaled to the system. The USB Interrupt bit in the HC status register is set either when the TD completes successfully or because of errors. If the completion is because of errors, the USB Error bit in the HC status register is also set.

### Short Packet Detect

A transfer set is a collection of data which requires more than one USB transaction to completely move the data across the USB. An example might be a large print file which requires numerous TDs in multiple frames to completely transfer the data. Reception of a data packet that is less than the endpoint's Max Packet size during Control, Bulk or Interrupt transfers signals the completion of the transfer set, even if there are active TDs remaining for this transfer set. Setting the SPD bit in a TD indicates to the HC to set the USB Interrupt bit in the HC status register at the end of the frame in which this event occurs. This feature streamlines the processing of input on these transfer types. If the Short Packet Interrupt Enable bit in the Interrupt Enable register is set, a hardware interrupt is signaled to the system at the end of the frame where the event occurred.

### Serial Bus Babble

When a device transmits on the USB for a time greater than its assigned Max Length, it is said to be babbling. Since isochrony can be destroyed by a babbling device, this error results in the Active bit in the TD being cleared to 0 and the Stalled and Babble bits being set to 1. The C\_ERR field is not decremented for a babble. The USB Error Interrupt bit in the HC Status register is set to 1 at the end of the frame. A hardware interrupt is signaled to the system.

If an EOF babble was caused by the ICH8 (due to incorrect schedule for instance), the ICH8 forces a bit stuff error followed by an EOP and the start of the next frame.

### Stalled

This event indicates that a device/endpoint returned a STALL handshake during a transaction or that the transaction ended in an error condition. The TDs Stalled bit is set and the Active bit is cleared. Reception of a STALL does not decrement the error counter. A hardware interrupt is signaled to the system.





### Data Buffer Error

This event indicates that an overrun of incoming data or a under-run of outgoing data has occurred for this transaction. This would generally be caused by the ICH8 not being able to access required data buffers in memory within necessary latency requirements. Either of these conditions causes the C\_ERR field of the TD to be decremented.

When C\_ERR decrements to 0, the Active bit in the TD is cleared, the Stalled bit is set, the USB Error Interrupt bit in the HC Status register is set to 1 at the end of the frame and a hardware interrupt is signaled to the system.

### Bit Stuff Error

A bit stuff error results from the detection of a sequence of more than six 1s in a row within the incoming data stream. This causes the C\_ERR field of the TD to be decremented. When the C\_ERR field decrements to 0, the Active bit in the TD is cleared to 0, the Stalled bit is set to 1, the USB Error Interrupt bit in the HC Status register is set to 1 at the end of the frame and a hardware interrupt is signaled to the system.

#### 5.18.6.2 Non-Transaction Based Interrupts

If an ICH8 process error or system error occur, the ICH8 halts and immediately issues a hardware interrupt to the system.

### Resume Received

This event indicates that the ICH8 received a RESUME signal from a device on the USB bus during a global suspend. If this interrupt is enabled in the Interrupt Enable register, a hardware interrupt is signaled to the system allowing the USB to be brought out of the suspend state and returned to normal operation.

### ICH8 Process Error

The HC monitors certain critical fields during operation to ensure that it does not process corrupted data structures. These include checking for a valid PID and verifying that the MaxLength field is less than 1280. If it detects a condition that would indicate that it is processing corrupted data structures, it immediately halts processing, sets the HC Process Error bit in the HC Status register and signals a hardware interrupt to the system.

This interrupt cannot be disabled through the Interrupt Enable register.

### Host System Error

The ICH8 sets this bit to 1 when a Parity error, Master Abort, or Target Abort occur. When this error occurs, the ICH8 clears the Run/Stop bit in the Command register to prevent further execution of the scheduled TDs. This interrupt cannot be disabled through the Interrupt Enable register.

## 5.18.7 USB Power Management

The Host controller can be put into a suspended state and its power can be removed. This requires that certain bits of information are retained in the resume power plane of the ICH8 so that a device on a port may wake the system. Such a device may be a fax-modem, which will wake up the machine to receive a fax or take a voice message. The settings of the following bits in I/O space will be maintained when the ICH8 enters the S3, S4, or S5 states.

**Table 84. Bits Maintained in Low Power States**

Register	Offset	Bit	Description
Command	00h	3	Enter Global Suspend Mode (EGSM)
Status	02h	2	Resume Detect
Port Status and Control	10h & 12h	2	Port Enabled/Disabled
		6	Resume Detect
		8	Low-speed Device Attached
		12	Suspend

When the ICH8 detects a resume event on any of its ports, it sets the corresponding USB\_STS bit in ACPI space. If USB is enabled as a wake/break event, the system wakes up and an SCI generated.

## 5.18.8 USB Legacy Keyboard Operation

When a USB keyboard is plugged into the system, and a standard keyboard is not, the system may not boot, and MS-DOS legacy software will not run, because the keyboard will not be identified. The ICH8 implements a series of trapping operations which will snoop accesses that go to the keyboard controller, and put the expected data from the USB keyboard into the keyboard controller.

**Note:** The scheme described below assumes that the keyboard controller (8042 or equivalent) is on the LPC bus.

This legacy operation is performed through SMM space. [Figure 15](#) shows the Enable and Status path. The latched SMI source (60R, 60W, 64R, 64W) is available in the Status Register. Because the enable is after the latch, it is possible to check for other events that didn't necessarily cause an SMI. It is the software's responsibility to logically AND the value with the appropriate enable bits.

Note also that the SMI is generated before the PCI cycle completes (e.g., before TRDY# goes active) to ensure that the processor doesn't complete the cycle before the SMI is observed. This method is used on MPIOX and has been validated.

The logic also needs to block the accesses to the 8042. If there is an external 8042, then this is simply accomplished by not activating the 8042 CS. This is simply done by logically ANDing the four enables (60R, 60W, 64R, 64W) with the 4 types of accesses to determine if 8042CS should go active. An additional term is required for the "pass-through" case.

The state table for the diagram is shown in [Table 85](#).



Figure 15. USB Legacy Keyboard Flow Diagram

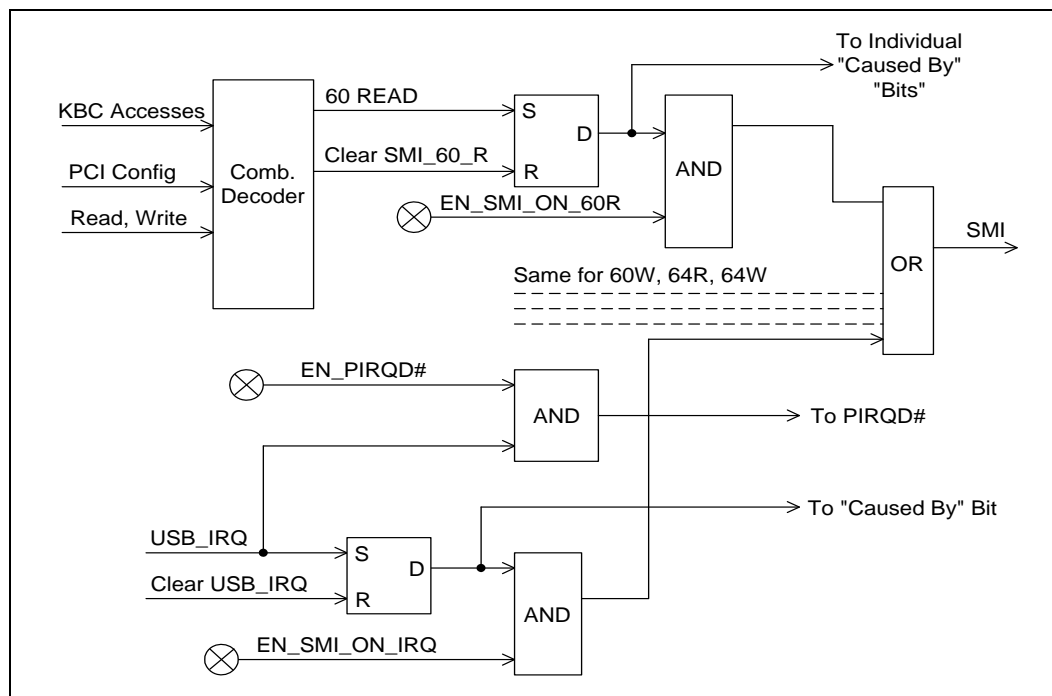


Table 85. USB Legacy Keyboard State Transitions

Current State	Action	Data Value	Next State	Comment
IDLE	64h / Write	D1h	GateState1	Standard D1 command. Cycle passed through to 8042. SMI# doesn't go active. PSTATE (offset C0, bit 6) goes to 1.
IDLE	64h / Write	Not D1h	IDLE	Bit 3 in Config Register determines if cycle passed through to 8042 and if SMI# generated.
IDLE	64h / Read	N/A	IDLE	Bit 2 in Config Register determines if cycle passed through to 8042 and if SMI# generated.
IDLE	60h / Write	Don't Care	IDLE	Bit 1 in Config Register determines if cycle passed through to 8042 and if SMI# generated.
IDLE	60h / Read	N/A	IDLE	Bit 0 in Config Register determines if cycle passed through to 8042 and if SMI# generated.
GateState1	60h / Write	XXh	GateState2	Cycle passed through to 8042, even if trap enabled in Bit 1 in Config Register. No SMI# generated. PSTATE remains 1. If data value is not DFh or DDh then the 8042 may chose to ignore it.



Table 85. USB Legacy Keyboard State Transitions

Current State	Action	Data Value	Next State	Comment
GateState1	64h / Write	D1h	GateState1	Cycle passed through to 8042, even if trap enabled via Bit 3 in Config Register. No SMI# generated. PSTATE remains 1. Stay in GateState1 because this is part of the double-trigger sequence.
GateState1	64h / Write	Not D1h	ILDE	Bit 3 in Config space determines if cycle passed through to 8042 and if SMI# generated. PSTATE goes to 0. If Bit 7 in Config Register is set, then SMI# should be generated.
GateState1	60h / Read	N/A	IDLE	This is an invalid sequence. Bit 0 in Config Register determines if cycle passed through to 8042 and if SMI# generated. PSTATE goes to 0. If Bit 7 in Config Register is set, then SMI# should be generated.
GateState1	64h / Read	N/A	GateState1	Just stay in same state. Generate an SMI# if enabled in Bit 2 of Config Register. PSTATE remains 1.
GateState2	64 / Write	FFh	IDLE	Standard end of sequence. Cycle passed through to 8042. PSTATE goes to 0. Bit 7 in Config Space determines if SMI# should be generated.
GateState2	64h / Write	Not FFh	IDLE	Improper end of sequence. Bit 3 in Config Register determines if cycle passed through to 8042 and if SMI# generated. PSTATE goes to 0. If Bit 7 in Config Register is set, then SMI# should be generated.
GateState2	64h / Read	N/A	GateState2	Just stay in same state. Generate an SMI# if enabled in Bit 2 of Config Register. PSTATE remains 1.
GateState2	60h / Write	XXh	IDLE	Improper end of sequence. Bit 1 in Config Register determines if cycle passed through to 8042 and if SMI# generated. PSTATE goes to 0. If Bit 7 in Config Register is set, then SMI# should be generated.
GateState2	60h / Read	N/A	IDLE	Improper end of sequence. Bit 0 in Config Register determines if cycle passed through to 8042 and if SMI# generated. PSTATE goes to 0. If Bit 7 in Config Register is set, then SMI# should be generated.



## 5.19 USB EHCI Host Controllers (D29:F7 and D26:F7)

The ICH8 contains two Enhanced Host Controller Interface (EHCI) host controllers which support up to ten USB 2.0 high-speed root ports. USB 2.0 allows data transfers up to 480 Mb/s using the same pins as the ten USB full-speed/low-speed ports. The ICH8 contains port-routing logic that determines whether a USB port is controlled by one of the UHCI controllers or by one of the EHCI controllers. USB 2.0 based Debug Port is also implemented in the ICH8.

A summary of the key architectural differences between the USB UHCI host controllers and the EHCI host controller are shown in [Table 86](#).

**Table 86. UHCI vs. EHCI**

Parameter	USB UHCI	USB EHCI
Accessible by	I/O space	Memory Space
Memory Data Structure	Single linked list	Separated in to Periodic and Asynchronous lists
Differential Signaling Voltage	3.3 V	400 mV
Ports per Controller	2	6 (controller #1) and 4 (Controller #2)

### 5.19.1 EHC Initialization

The following descriptions step through the expected ICH8 Enhanced Host Controller (EHC) initialization sequence in chronological order, beginning with a complete power cycle in which the suspend well and core well have been off.

#### 5.19.1.1 BIOS Initialization

BIOS performs a number of platform customization steps after the core well has powered up. Contact your Intel Field Representative for additional ICH8 BIOS information.

#### 5.19.1.2 Driver Initialization

See Chapter 4 of the *Enhanced Host Controller Interface Specification for Universal Serial Bus*, Revision 1.0.

### 5.19.1.3 EHC Resets

In addition to the standard ICH8 hardware resets, portions of the EHC are reset by the HCRESET bit and the transition from the D3<sub>HOT</sub> device power management state to the D0 state. The effects of each of these resets are listed in the following table.

Reset	Does Reset	Does not Reset	Comments
HCRESET bit set.	Memory space registers except Structural Parameters (which is written by BIOS).	Configuration registers.	The HCRESET must only affect registers that the EHCI driver controls. PCI Configuration space and BIOS-programmed parameters can not be reset.
Software writes the Device Power State from D3 <sub>HOT</sub> (11b) to D0 (00b).	Core well registers (except BIOS-programmed registers).	Suspend well registers; BIOS-programmed core well registers.	The D3-to-D0 transition must not cause wake information (suspend well) to be lost. It also must not clear BIOS-programmed registers because BIOS may not be invoked following the D3-to-D0 transition.

If the detailed register descriptions give exceptions to these rules, those exceptions override these rules. This summary is provided to help explain the reasons for the reset policies.

### 5.19.2 Data Structures in Main Memory

See Section 3 and Appendix B of the *Enhanced Host Controller Interface Specification for Universal Serial Bus*, Revision 1.0 for details.

### 5.19.3 USB 2.0 Enhanced Host Controller DMA

The ICH8 USB 2.0 EHC implements three sources of USB packets. They are, in order of priority on USB during each microframe:

1. The USB 2.0 Debug Port (see Section USB 2.0 Based Debug Port),
2. The Periodic DMA engine, and
3. The Asynchronous DMA engine. The ICH8 always performs any currently-pending debug port transaction at the beginning of a microframe, followed by any pending periodic traffic for the current microframe. If there is time left in the microframe, then the EHC performs any pending asynchronous traffic until the end of the microframe (EOF1). Note that the debug port traffic is only presented on one port (Port #0), while the other ports are idle during this time.

### 5.19.4 Data Encoding and Bit Stuffing

See Chapter 8 of the *Universal Serial Bus Specification, Revision 2.0*.

### 5.19.5 Packet Formats

See Chapter 8 of the *Universal Serial Bus Specification, Revision 2.0*.

The ICH8 EHCI allows entrance to USB test modes, as defined in the USB 2.0 specification, including Test J, Test Packet, etc. However note that the ICH8 Test Packet test mode interpacket gap timing may not meet the USB 2.0 specification.



## 5.19.6 USB 2.0 Interrupts and Error Conditions

Section 4 of the *Enhanced Host Controller Interface Specification for Universal Serial Bus*, Revision 1.0 goes into detail on the EHC interrupts and the error conditions that cause them. All error conditions that the EHC detects can be reported through the EHCI Interrupt status bits. Only ICH8-specific interrupt and error-reporting behavior is documented in this section. The EHCI Interrupts Section must be read first, followed by this section of the datasheet to fully comprehend the EHC interrupt and error-reporting functionality.

- Based on the EHC's Buffer sizes and buffer management policies, the Data Buffer Error can never occur on the ICH8.
- Master Abort and Target Abort responses from hub interface on EHC-initiated read packets will be treated as Fatal Host Errors. The EHC halts when these conditions are encountered.
- The ICH8 may assert the interrupts which are based on the interrupt threshold as soon as the status for the last complete transaction in the interrupt interval has been posted in the internal write buffers. The requirement in the *Enhanced Host Controller Interface Specification for Universal Serial Bus*, Revision 1.0 (that the status is written to memory) is met internally, even though the write may not be seen on DMI before the interrupt is asserted.
- Since the ICH8 supports the 1024-element Frame List size, the Frame List Rollover interrupt occurs every 1024 milliseconds.
- The ICH8 delivers interrupts using PIRQ#.
- The ICH8 does not modify the CERR count on an Interrupt IN when the "Do Complete-Split" execution criteria are not met.
- For complete-split transactions in the Periodic list, the "Missed Microframe" bit does not get set on a control-structure-fetch that fails the late-start test. If subsequent accesses to that control structure do not fail the late-start test, then the "Missed Microframe" bit will get set and written back.

### 5.19.6.1 Aborts on USB 2.0-Initiated Memory Reads

If a read initiated by the EHC is aborted, the EHC treats it as a fatal host error. The following actions are taken when this occurs:

- The Host System Error status bit is set
- The DMA engines are halted after completing up to one more transaction on the USB interface
- If enabled (by the Host System Error Enable), then an interrupt is generated
- If the status is Master Abort, then the Received Master Abort bit in configuration space is set
- If the status is Target Abort, then the Received Target Abort bit in configuration space is set
- If enabled (by the SERR Enable bit in the function's configuration space), then the Signaled System Error bit in configuration bit is set.



## 5.19.7 USB 2.0 Power Management

### 5.19.7.1 USB Pre-Fetch Pause Feature

The Pre-Fetch Based Pause is a power management feature in USB (EHCI) host controllers to ensure maximum C3/C4 CPU power state time with C2 popup. This feature applies to the period schedule and works by allowing the DMA engine to identify periods of idleness and prevents the DMA engine from accessing memory when the periodic schedule is idle. Typically in the presence of periodic devices with multiple millisecond poll periods, the periodic schedule will be idle for several frames between polls.

The USB Pre-Fetch Based Pause feature is disabled by setting bit 4 of EHCI Configuration Register [Section 15.1.30](#).

### 5.19.7.2 Suspend Feature

The *Enhanced Host Controller Interface (EHCI) For Universal Serial Bus Specification*, Section 4.3 describes the details of Port Suspend and Resume.

### 5.19.7.3 ACPI Device States

The USB 2.0 function only supports the D0 and D3 PCI Power Management states. Notes regarding the ICH8 implementation of the Device States:

1. The EHC hardware does not inherently consume any more power when it is in the D0 state than it does in the D3 state. However, software is required to suspend or disable all ports prior to entering the D3 state such that the maximum power consumption is reduced.
2. In the D0 state, all implemented EHC features are enabled.
3. In the D3 state, accesses to the EHC memory-mapped I/O range will master abort. Note that, since the Debug Port uses the same memory range, the Debug Port is only operational when the EHC is in the D0 state.
4. In the D3 state, the EHC interrupt must never assert for any reason. The internal PME# signal is used to signal wake events, etc.
5. When the Device Power State field is written to D0 from D3, an internal reset is generated. See section EHC Resets for general rules on the effects of this reset.
6. Attempts to write any other value into the Device Power State field other than 00b (D0 state) and 11b (D3 state) will complete normally without changing the current value in this field.





#### 5.19.7.4 ACPI System States

The EHC behavior as it relates to other power management states in the system is summarized in the following list:

- The System is always in the S0 state when the EHC is in the D0 state. However, when the EHC is in the D3 state, the system may be in any power management state (including S0).
- When in D0, the Pause feature (See [Section 5.19.7.1](#)) enables dynamic processor low-power states to be entered.
- The PLL in the EHC is disabled when entering the S3/S4/S5 states (core power turns off).
- All core well logic is reset in the S3/S4/S5 states.

#### 5.19.7.5 Mobile Considerations

The ICH8 USB 2.0 implementation does not behave differently in the mobile configurations versus the desktop configurations. However, some features may be especially useful for the mobile configurations.

- If a system (e.g., mobile) does not implement all ten USB 2.0 ports, the ICH8 provides mechanisms for changing the structural parameters of the EHC and hiding unused UHCI controllers. See the *Intel<sup>®</sup> ICH8 BIOS Specification* for information on how BIOS should configure the ICH8.
- Mobile systems may want to minimize the conditions that will wake the system. The ICH8 implements the “Wake Enable” bits in the Port Status and Control registers, as specified in the EHCI spec, for this purpose.
- Mobile systems may want to cut suspend well power to some or all USB ports when in a low-power state. The ICH8 implements the optional Port Wake Capability Register in the EHC Configuration Space for this platform-specific information to be communicated to software.

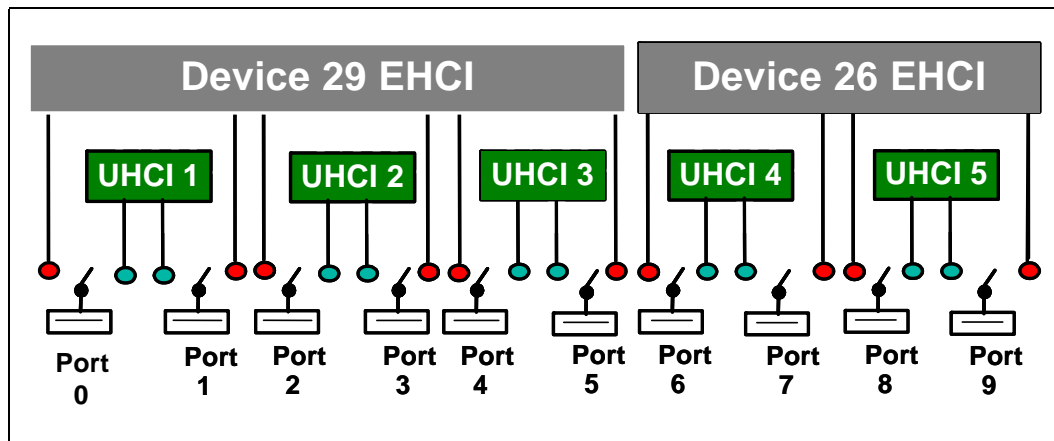
### 5.19.8 Interaction with UHCI Host Controllers

The Enhanced Host controllers share its ports with UHCI Host controllers in the ICH8. The UHC at D29:F0 shares ports 0 and 1; the UHC at D29:F1 shares ports 2 and 3; the UHC at D29:F2 shares ports 4 and 5 with the EHC at D29:F7, while the UHC at D26:F0 shares ports 6 and 7, the UHC at D26:F1 shares ports 8 and 9 with EHC at D26:F7. There is very little interaction between the Enhanced and the UHCI controllers other than the multiplexing control which is provided as part of the EHC. [Figure 16](#) shows the USB Port Connections at a conceptual level.

#### 5.19.8.1 Port-Routing Logic

Integrated into the EHC functionality is port-routing logic, which performs the muxing between the UHCI and EHCI host controllers. The ICH8 conceptually implements this logic as described in Section 4.2 of the *Enhanced Host Controller Interface Specification for Universal Serial Bus*, Revision 1.0. If a device is connected that is not capable of USB 2.0's high-speed signaling protocol or if the EHCI software drivers are not present as indicated by the Configured Flag, then the UHCI controller owns the port. Owning the port means that the differential output is driven by the owner and the input stream is only visible to the owner. The host controller that is not the owner of the port internally sees a disconnected port.

Figure 16. Intel® ICH8-USB Port Connections



Note that the port-routing logic is the only block of logic within the ICH8 that observes the physical (real) connect/disconnect information. The port status logic inside each of the host controllers observes the electrical connect/disconnect information that is generated by the port-routing logic.

Only the differential signal pairs are multiplexed/demultiplexed between the UHCI and EHCI host controllers. The other USB functional signals are handled as follows:

- The Overcurrent inputs (OC[9:0]#) are directly routed to both controllers. An overcurrent event is recorded in both controllers' status registers.

The Port-Routing logic is implemented in the Suspend power well so that re-enumeration and re-mapping of the USB ports is not required following entering and exiting a system sleep state in which the core power is turned off.

The ICH8 also allows the USB Debug Port traffic to be routed in and out of Port #0. When in this mode, the Enhanced Host controller is the owner of Port 0.

### 5.19.8.2 Device Connects

The *Enhanced Host Controller Interface Specification for Universal Serial Bus, Revision 1.0* describes the details of handling Device Connects in Section 4.2. There are four general scenarios that are summarized below.

1. Configure Flag = 0 and a full-speed/low-speed-only Device is connected
  - In this case, the UHC is the owner of the port both before and after the connect occurs. The EHC (except for the port-routing logic) never sees the connect occur. The UHCI driver handles the connection and initialization process.
2. Configure Flag = 0 and a high-speed-capable Device is connected
  - In this case, the UHC is the owner of the port both before and after the connect occurs. The EHC (except for the port-routing logic) never sees the connect occur. The UHCI driver handles the connection and initialization process. Since the UHC does not perform the high-speed chirp handshake, the device operates in compatible mode.
3. Configure Flag = 1 and a full-speed/low-speed-only Device is connected
  - In this case, the EHC is the owner of the port before the connect occurs. The EHCI driver handles the connection and performs the port reset. After the reset process completes, the EHC hardware has cleared (not set) the Port Enable bit in the EHC's PORTSC register. The EHCI driver then writes a 1 to the Port Owner



bit in the same register, causing the UHC to see a connect event and the EHC to see an “electrical” disconnect event. The UHCI driver and hardware handle the connection and initialization process from that point on. The EHCI driver and hardware handle the perceived disconnect.

4. Configure Flag = 1 and a high-speed-capable Device is connected
  - In this case, the EHC is the owner of the port before, and remains the owner after, the connect occurs. The EHCI driver handles the connection and performs the port reset. After the reset process completes, the EHC hardware has set the Port Enable bit in the EHC’s PORTSC register. The port is functional at this point. The UHC continues to see an unconnected port.

### 5.19.8.3 Device Disconnects

The *Enhanced Host Controller Interface Specification for Universal Serial Bus*, Revision 1.0 describes the details of handling Device Connects in Section 4.2. There are three general scenarios that are summarized below.

1. Configure Flag = 0 and the device is disconnected
  - In this case, the UHC is the owner of the port both before and after the disconnect occurs. The EHC (except for the port-routing logic) never sees a device attached. The UHCI driver handles disconnection process.
2. Configure Flag = 1 and a full-speed/low-speed-capable Device is disconnected
  - In this case, the UHC is the owner of the port before the disconnect occurs. The disconnect is reported by the UHC and serviced by the associated UHCI driver. The port-routing logic in the EHC cluster forces the Port Owner bit to 0, indicating that the EHC owns the unconnected port.
3. Configure Flag = 1 and a high-speed-capable Device is disconnected
  - In this case, the EHC is the owner of the port before, and remains the owner after, the disconnect occurs. The EHCI hardware and driver handle the disconnection process. The UHC never sees a device attached.

### 5.19.8.4 Effect of Resets on Port-Routing Logic

As mentioned above, the Port Routing logic is implemented in the suspend power well so that remuneration and re-mapping of the USB ports is not required following entering and exiting a system sleep state in which the core power is turned off.

Reset Event	Effect on Configure Flag	Effect on Port Owner Bits
Suspend Well Reset	cleared (0)	set (1)
Core Well Reset	no effect	no effect
D3-to-D0 Reset	no effect	no effect
HCRESET	cleared (0)	set (1)

### 5.19.9 USB 2.0 Legacy Keyboard Operation

The ICH8 must support the possibility of a keyboard downstream from either a full-speed/low-speed or a high-speed port. The description of the legacy keyboard support is unchanged from USB 1.1 (See [Section 5.18.8](#)).

The EHC provides the basic ability to generate SMIs on an interrupt event, along with more sophisticated control of the generation of SMIs.



## 5.19.10 USB 2.0 Based Debug Port

The ICH8 supports the elimination of the legacy COM ports by providing the ability for new debugger software to interact with devices on a USB 2.0 port.

High-level restrictions and features are:

- Operational before USB 2.0 drivers are loaded.
- Functions even when the port is disabled.
- Works even though non-configured port is default-routed to the UHCI. Note that the Debug Port can not be used to debug an issue that requires a full-speed/low-speed device on Port #0 using the UHCI drivers.
- Allows normal system USB 2.0 traffic in a system that may only have one USB port.
- Debug Port device (DPD) must be high-speed capable and connect directly to Port #0 on ICH8 systems (e.g., the DPD cannot be connected to Port #0 through a hub).
- Debug Port FIFO always makes forward progress (a bad status on USB is simply presented back to software).
- The Debug Port FIFO is only given one USB access per microframe.

The Debug port facilitates operating system and device driver debug. It allows the software to communicate with an external console using a USB 2.0 connection. Because the interface to this link does not go through the normal USB 2.0 stack, it allows communication with the external console during cases where the operating system is not loaded, the USB 2.0 software is broken, or where the USB 2.0 software is being debugged. Specific features of this implementation of a debug port are:

- Only works with an external USB 2.0 debug device (console)
- Implemented for a specific port on the host controller
- Operational anytime the port is not suspended AND the host controller is in D0 power state.
- Capability is interrupted when port is driving USB RESET

### 5.19.10.1 Theory of Operation

There are two operational modes for the USB debug port:

1. Mode 1 is when the USB port is in a disabled state from the viewpoint of a standard host controller driver. In Mode 1, the Debug Port controller is required to generate a “keepalive” packets less than 2 ms apart to keep the attached debug device from suspending. The keepalive packet should be a standalone 32-bit SYNC field.
2. Mode 2 is when the host controller is running (i.e., host controller’s *Run/Stop#* bit is 1). In Mode 2, the normal transmission of SOF packets will keep the debug device from suspending.

#### Behavioral Rules

1. In both modes 1 and 2, the Debug Port controller must check for software requested debug transactions at least every 125 microseconds.
2. If the debug port is enabled by the debug driver, and the standard host controller driver resets the USB port, USB debug transactions are held off for the duration of the reset and until after the first SOF is sent.
3. If the standard host controller driver suspends the USB port, then USB debug transactions are held off for the duration of the suspend/resume sequence and until after the first SOF is sent.
4. The ENABLED\_CNT bit in the debug register space is independent of the similar port control bit in the associated Port Status and Control register.



Table 87 shows the debug port behavior related to the state of bits in the debug registers as well as bits in the associated Port Status and Control register.

**Table 87. Debug Port Behavior**

OWNER_CNT	ENABLED_CT	Port Enable	Run / Stop	Suspend	Debug Port Behavior
0	X	X	X	X	Debug port is not being used. Normal operation.
1	0	X	X	X	Debug port is not being used. Normal operation.
1	1	0	0	X	Debug port in Mode 1. SYNC keepalives sent plus debug traffic
1	1	0	1	X	Debug port in Mode 2. SOF (and only SOF) is sent as keepalive. Debug traffic is also sent. Note that no other normal traffic is sent out this port, because the port is not enabled.
1	1	1	0	0	Invalid. Host controller driver should never put controller into this state (enabled, not running and not suspended).
1	1	1	0	1	Port is suspended. No debug traffic sent.
1	1	1	1	0	Debug port in Mode 2. Debug traffic is interspersed with normal traffic.
1	1	1	1	1	Port is suspended. No debug traffic sent.



### 5.19.10.1.1 OUT Transactions

An Out transaction sends data to the debug device. It can occur only when the following are true:

- The debug port is enabled
- The debug software sets the GO\_CNT bit
- The WRITE\_READ#\_CNT bit is set

The sequence of the transaction is:

1. Software sets the appropriate values in the following bits:
  - USB\_ADDRESS\_CNF
  - USB\_ENDPOINT\_CNF
  - DATA\_BUFFER[63:0]
  - TOKEN\_PID\_CNT[7:0]
  - SEND\_PID\_CNT[15:8]
  - DATA\_LEN\_CNT
  - WRITE\_READ#\_CNT (note: this will always be 1 for OUT transactions)
  - GO\_CNT (note: this will always be 1 to initiate the transaction)
2. The debug port controller sends a token packet consisting of:
  - SYNC
  - TOKEN\_PID\_CNT field
  - USB\_ADDRESS\_CNT field
  - USB\_ENDPOINT\_CNT field
  - 5-bit CRC field
3. After sending the token packet, the debug port controller sends a data packet consisting of:
  - SYNC
  - SEND\_PID\_CNT field
  - The number of data bytes indicated in DATA\_LEN\_CNT from the DATA\_BUFFER
  - 16-bit CRC

NOTE: A DATA\_LEN\_CNT value of 0 is valid in which case no data bytes would be included in the packet.

4. After sending the data packet, the controller waits for a handshake response from the debug device.
  - If a handshake is received, the debug port controller:
    - a. Places the received PID in the RECEIVED\_PID\_STS field
    - b. Resets the ERROR\_GOOD#\_STS bit
    - c. Sets the DONE\_STS bit
  - If no handshake PID is received, the debug port controller:
    - a. Sets the EXCEPTION\_STS field to 001b
    - b. Sets the ERROR\_GOOD#\_STS bit
    - c. Sets the DONE\_STS bit



### 5.19.10.1.2 IN Transactions

An IN transaction receives data from the debug device. It can occur only when the following are true:

- The debug port is enabled
- The debug software sets the GO\_CNT bit
- The WRITE\_READ#\_CNT bit is reset

The sequence of the transaction is:

1. Software sets the appropriate values in the following bits:
  - USB\_ADDRESS\_CNF
  - USB\_ENDPOINT\_CNF
  - TOKEN\_PID\_CNT[7:0]
  - DATA\_LEN\_CNT
  - WRITE\_READ#\_CNT (note: this will always be 0 for IN transactions)
  - GO\_CNT (note: this will always be 1 to initiate the transaction)
2. The debug port controller sends a token packet consisting of:
  - SYNC
  - TOKEN\_PID\_CNT field
  - USB\_ADDRESS\_CNF field
  - USB\_ENDPOINT\_CNF field
  - 5-bit CRC field.
3. After sending the token packet, the debug port controller waits for a response from the debug device.  
If a response is received:
  - The received PID is placed into the RECEIVED\_PID\_STS field
  - Any subsequent bytes are placed into the DATA\_BUFFER
  - The DATA\_LEN\_CNT field is updated to show the number of bytes that were received after the PID.
4. If valid packet was received from the device that was one byte in length (indicating it was a handshake packet), then the debug port controller:
  - Resets the ERROR\_GOOD#\_STS bit
  - Sets the DONE\_STS bit
5. If valid packet was received from the device that was more than one byte in length (indicating it was a data packet), then the debug port controller:
  - Transmits an ACK handshake packet
  - Resets the ERROR\_GOOD#\_STS bit
  - Sets the DONE\_STS bit
6. If no valid packet is received, then the debug port controller:
  - Sets the EXCEPTION\_STS field to 001b
  - Sets the ERROR\_GOOD#\_STS bit
  - Sets the DONE\_STS bit.

### 5.19.10.1.3 Debug Software

#### Enabling the Debug Port

There are two mutually exclusive conditions that debug software must address as part of its startup processing:

- The EHCI has been initialized by system software
- The EHCI has not been initialized by system software

Debug software can determine the current 'initialized' state of the EHCI by examining the Configure Flag in the EHCI USB 2.0 Command Register. If this flag is set, then system software has initialized the EHCI. Otherwise the EHCI should not be considered initialized. Debug software will initialize the debug port registers depending on the state the EHCI. However, before this can be accomplished, debug software must determine which root USB port is designated as the debug port.

#### Determining the Debug Port

Debug software can easily determine which USB root port has been designated as the debug port by examining bits 20:23 of the EHCI Host Controller Structural Parameters register. This 4-bit field represents the numeric value assigned to the debug port (i.e., 0000=port 0).

#### Debug Software Startup with Non-Initialized EHCI

Debug software can attempt to use the debug port if after setting the OWNER\_CNT bit, the Current Connect Status bit in the appropriate (See Determining the Debug Port) PORTSC register is set. If the Current Connect Status bit is not set, then debug software may choose to terminate or it may choose to wait until a device is connected.

If a device is connected to the port, then debug software must reset/enable the port. Debug software does this by setting and then clearing the Port Reset bit the PORTSC register. To assure a successful reset, debug software should wait at least 50 ms before clearing the Port Reset bit. Due to possible delays, this bit may not change to 0 immediately; reset is complete when this bit reads as 0. Software must not continue until this bit reads 0.

If a high-speed device is attached, the EHCI will automatically set the Port Enabled/Disabled bit in the PORTSC register and the debug software can proceed. Debug software should set the ENABLED\_CNT bit in the Debug Port Control/Status register, and then reset (clear) the Port Enabled/Disabled bit in the PORTSC register (so that the system host controller driver does not see an enabled port when it is first loaded).

#### Debug Software Startup with Initialized EHCI

Debug software can attempt to use the debug port if the Current Connect Status bit in the appropriate (See Determining the Debug Port) PORTSC register is set. If the Current Connect Status bit is not set, then debug software may choose to terminate or it may choose to wait until a device is connected.

If a device is connected, then debug software must set the OWNER\_CNT bit and then the ENABLED\_CNT bit in the Debug Port Control/Status register.

#### Determining Debug Peripheral Presence

After enabling the debug port functionality, debug software can determine if a debug peripheral is attached by attempting to send data to the debug peripheral. If all attempts result in an error (Exception bits in the Debug Port Control/Status register indicates a Transaction Error), then the attached device is not a debug peripheral. If the debug port peripheral is not present, then debug software may choose to terminate or it may choose to wait until a debug peripheral is connected.





## 5.20 SMBus Controller (D31:F3)

The ICH8 provides an System Management Bus (SMBus) 2.0 host controller as well as an SMBus Slave Interface. The host controller provides a mechanism for the processor to initiate communications with SMBus peripherals (slaves). The ICH8 is also capable of operating in a mode in which it can communicate with I<sup>2</sup>C compatible devices.

The ICH8 can perform SMBus messages with either packet error checking (PEC) enabled or disabled. The actual PEC calculation and checking is performed in hardware by the ICH8.

The Slave Interface allows an external master to read from or write to the ICH8. Write cycles can be used to cause certain events or pass messages, and the read cycles can be used to determine the state of various status bits. The ICH8's internal host controller cannot access the ICH8's internal Slave Interface.

The ICH8 SMBus logic exists in Device 31:Function 3 configuration space, and consists of a transmit data path, and host controller. The transmit data path provides the data flow logic needed to implement the seven different SMBus command protocols and is controlled by the host controller. The ICH8 SMBus controller logic is clocked by RTC clock.

The SMBus Address Resolution Protocol (ARP) is supported by using the existing host controller commands through software, except for the new Host Notify command (which is actually a received message).

The programming model of the host controller is combined into two portions: a PCI configuration portion, and a system I/O mapped portion. All static configuration, such as the I/O base address, is done via the PCI configuration space. Real-time programming of the Host interface is done in system I/O space.

The ICH8 SMBus host controller checks for parity errors as a target. If an error is detected, the detected parity error bit in the PCI Status Register (Device 31:Function 3:Offset 06h:bit 15) is set. If bit 6 and bit 8 of the PCI Command Register (Device 31:Function 3:Offset 04h) are set, an SERR# is generated and the signaled SERR# bit in the PCI Status Register (bit 14) is set.

Note that the ICH8 SMBus controller may stop responding if an SMBus device suddenly stops transmitting in the middle of a packet. This could result in unexpected system behavior, including a system hang.

### 5.20.1 Host Controller

The SMBus host controller is used to send commands to other SMBus slave devices. Software sets up the host controller with an address, command, and, for writes, data and optional PEC; and then tells the controller to start. When the controller has finished transmitting data on writes, or receiving data on reads, it generates an SMI# or interrupt, if enabled.

The host controller supports 8 command protocols of the SMBus interface (see *System Management Bus (SMBus) Specification, Version 2.0*): Quick Command, Send Byte, Receive Byte, Write Byte/Word, Read Byte/Word, Process Call, Block Read/Write, Block Write–Block Read Process Call, and Host Notify.

The SMBus host controller requires that the various data and command fields be setup for the type of command to be sent. When software sets the START bit, the SMBus Host controller performs the requested transaction, and interrupts the processor (or generates an SMI#) when the transaction is completed. Once a START command has been issued, the values of the "active registers" (Host Control, Host Command, Transmit Slave Address, Data 0, Data 1) should not be changed or read until the



interrupt status bit (INTR) has been set (indicating the completion of the command). Any register values needed for computation purposes should be saved prior to issuing of a new command, as the SMBus host controller updates all registers while completing the new command.

The ICH8 supports the *System Management Bus (SMBus) Specification, Version 2.0*. Slave functionality, including the Host Notify protocol, is available on the SMBus pins. The SMLink and SMBus signals should not be tied together externally.

Using the SMB host controller to send commands to the ICH8's SMB slave port is not supported.

### 5.20.1.1 Command Protocols

In all of the following commands, the Host Status Register (offset 00h) is used to determine the progress of the command. While the command is in operation, the HOST\_BUSY bit is set. If the command completes successfully, the INTR bit will be set in the Host Status Register. If the device does not respond with an acknowledge, and the transaction times out, the DEV\_ERR bit is set. If software sets the KILL bit in the Host Control Register while the command is running, the transaction will stop and the FAILED bit will be set.

#### Quick Command

When programmed for a Quick Command, the Transmit Slave Address Register is sent. The PEC byte is never appended to the Quick Protocol. Software should force the PEC\_EN bit to 0 when performing the Quick Command. Software must force the I2C\_EN bit to 0 when running this command. See Section 5.5.1 of the *System Management Bus (SMBus) Specification, Version 2.0* for the format of the protocol.

#### Send Byte / Receive Byte

For the Send Byte command, the Transmit Slave Address and Device Command Registers are sent. For the Receive Byte command, the Transmit Slave Address Register is sent. The data received is stored in the DATA0 register. Software must force the I2C\_EN bit to 0 when running this command.

The Receive Byte is similar to a Send Byte, the only difference is the direction of data transfer. See Sections 5.5.2 and 5.5.3 of the *System Management Bus (SMBus) Specification, Version 2.0* for the format of the protocol.

#### Write Byte/Word

The first byte of a Write Byte/Word access is the command code. The next 1 or 2 bytes are the data to be written. When programmed for a Write Byte/Word command, the Transmit Slave Address, Device Command, and Data0 Registers are sent. In addition, the Data1 Register is sent on a Write Word command. Software must force the I2C\_EN bit to 0 when running this command. See Section 5.5.4 of the *System Management Bus (SMBus) Specification, Version 2.0* for the format of the protocol.

#### Read Byte/Word

Reading data is slightly more complicated than writing data. First the ICH8 must write a command to the slave device. Then it must follow that command with a repeated start condition to denote a read from that device's address. The slave then returns 1 or 2 bytes of data. Software must force the I2C\_EN bit to 0 when running this command.



When programmed for the read byte/word command, the Transmit Slave Address and Device Command Registers are sent. Data is received into the DATA0 on the read byte, and the DATA0 and DATA1 registers on the read word. See Section 5.5.5 of the *System Management Bus (SMBus) Specification, Version 2.0* for the format of the protocol.

### Process Call

The process call is so named because a command sends data and waits for the slave to return a value dependent on that data. The protocol is simply a Write Word followed by a Read Word, but without a second command or stop condition.

When programmed for the Process Call command, the ICH8 transmits the Transmit Slave Address, Host Command, DATA0 and DATA1 registers. Data received from the device is stored in the DATA0 and DATA1 registers. The Process Call command with I2C\_EN set and the PEC\_EN bit set produces undefined results. Software must force either I2C\_EN or PEC\_EN to 0 when running this command. See Section 5.5.6 of the *System Management Bus (SMBus) Specification, Version 2.0* for the format of the protocol.

**Note:** For process call command, the value written into bit 0 of the Transmit Slave Address Register (SMB I/O register, offset 04h) needs to be 0.

**Note:** If the I2C\_EN bit is set, the protocol sequence changes slightly: the Command Code (bits 18:11 in the bit sequence) are not sent - as a result, the slave will not acknowledge (bit 19 in the sequence).

### Block Read/Write

The ICH8 contains a 32-byte buffer for read and write data which can be enabled by setting bit 1 of the Auxiliary Control register at offset 0Dh in I/O space, as opposed to a single byte of buffering. This 32-byte buffer is filled with write data before transmission, and filled with read data on reception. In the ICH8, the interrupt is generated only after a transmission or reception of 32 bytes, or when the entire byte count has been transmitted/received.

The byte count field is transmitted but ignored by the ICH8 as software will end the transfer after all bytes it cares about have been sent or received.

For a Block Write, software must either force the I2C\_EN bit or both the PEC\_EN and AAC bits to 0 when running this command.

The block write begins with a slave address and a write condition. After the command code the ICH8 issues a byte count describing how many more bytes will follow in the message. If a slave had 20 bytes to send, the first byte would be the number 20 (14h), followed by 20 bytes of data. The byte count may not be 0. A Block Read or Write is allowed to transfer a maximum of 32 data bytes.

When programmed for a block write command, the Transmit Slave Address, Device Command, and Data0 (count) registers are sent. Data is then sent from the Block Data Byte register; the total data sent being the value stored in the Data0 Register. On block read commands, the first byte received is stored in the Data0 register, and the remaining bytes are stored in the Block Data Byte register. See Section 5.5.7 of the *System Management Bus (SMBus) Specification, Version 2.0* for the format of the protocol.

**Note:** For Block Write, if the I2C\_EN bit is set, the format of the command changes slightly. The ICH8 will still send the number of bytes (on writes) or receive the number of bytes (on reads) indicated in the DATA0 register. However, it will not send the contents of the DATA0 register as part of the message. Also, the Block Write protocol sequence



changes slightly: the Byte Count (bits 27:20 in the bit sequence) are not sent - as a result, the slave will not acknowledge (bit 28 in the sequence).

## I<sup>2</sup>C Read

This command allows the ICH8 to perform block reads to certain I<sup>2</sup>C devices, such as serial E<sup>2</sup>PROMs. The SMBus Block Read supports the 7-bit addressing mode only.

However, this does not allow access to devices using the I<sup>2</sup>C "Combined Format" that has data bytes after the address. Typically these data bytes correspond to an offset (address) within the serial memory chips.

**Note:** This command is supported independent of the setting of the I2C\_EN bit. The I<sup>2</sup>C Read command with the PEC\_EN bit set produces undefined results. Software must force both the PEC\_EN and AAC bit to 0 when running this command.

For I<sup>2</sup>C Read command, the value written into bit 0 of the Transmit Slave Address Register (SMB I/O register, offset 04h) needs to be 0.

The format that is used for the command is shown in [Table 88](#).

**Table 88.** I<sup>2</sup>C Block Read

Bit	Description
1	Start
8:2	Slave Address — 7 bits
9	Write
10	Acknowledge from slave
18:11	Send DATA1 register
19	Acknowledge from slave
20	Repeated Start
27:21	Slave Address — 7 bits
28	Read
29	Acknowledge from slave
37:30	Data byte 1 from slave — 8 bits
38	Acknowledge
46:39	Data byte 2 from slave — 8 bits
47	Acknowledge
–	Data bytes from slave / Acknowledge
–	Data byte N from slave — 8 bits
–	NOT Acknowledge
–	Stop

The ICH8 will continue reading data from the peripheral until the NAK is received.



### Block Write–Block Read Process Call

The block write-block read process call is a two-part message. The call begins with a slave address and a write condition. After the command code the host issues a write byte count ( $M$ ) that describes how many more bytes will be written in the first part of the message. If a master has 6 bytes to send, the byte count field will have the value 6 (0000 0110b), followed by the 6 bytes of data. The write byte count ( $M$ ) cannot be 0.

The second part of the message is a block of read data beginning with a repeated start condition followed by the slave address and a Read bit. The next byte is the read byte count ( $N$ ), which may differ from the write byte count ( $M$ ). The read byte count ( $N$ ) cannot be 0.

The combined data payload must not exceed 32 bytes. The byte length restrictions of this process call are summarized as follows:

- $M \geq 1$  byte
- $N \geq 1$  byte
- $M + N \leq 32$  bytes

The read byte count does not include the PEC byte. The PEC is computed on the total message beginning with the first slave address and using the normal PEC computational rules. It is highly recommended that a PEC byte be used with the Block Write-Block Read Process Call. Software must do a read to the command register (offset 2h) to reset the 32 byte buffer pointer prior to reading the block data register.

Note that there is no STOP condition before the repeated START condition, and that a NACK signifies the end of the read transfer.

**Note:** E32B bit in the Auxiliary Control register must be set when using this protocol.

See Section 5.5.8 of the *System Management Bus (SMBus) Specification, Version 2.0* for the format of the protocol.

## 5.20.2 Bus Arbitration

Several masters may attempt to get on the bus at the same time by driving the SMBDATA line low to signal a start condition. The ICH8 continuously monitors the SMBDATA line. When the ICH8 is attempting to drive the bus to a 1 by letting go of the SMBDATA line, and it samples SMBDATA low, then some other master is driving the bus and the ICH8 will stop transferring data.

If the ICH8 sees that it has lost arbitration, the condition is called a collision. The ICH8 will set the BUS\_ERR bit in the Host Status Register, and if enabled, generate an interrupt or SMI#. The processor is responsible for restarting the transaction.

When the ICH8 is a SMBus master, it drives the clock. When the ICH8 is sending address or command as an SMBus master, or data bytes as a master on writes, it drives data relative to the clock it is also driving. It will not start toggling the clock until the start or stop condition meets proper setup and hold time. The ICH8 will also assure minimum time between SMBus transactions as a master.

**Note:** The ICH8 supports the same arbitration protocol for both the SMBus and the System Management (SMLINK) interfaces.



## 5.20.3 Bus Timing

### 5.20.3.1 Clock Stretching

Some devices may not be able to handle their clock toggling at the rate that the ICH8 as an SMBus master would like. They have the capability of stretching the low time of the clock. When the ICH8 attempts to release the clock (allowing the clock to go high), the clock will remain low for an extended period of time.

The ICH8 monitors the SMBus clock line after it releases the bus to determine whether to enable the counter for the high time of the clock. While the bus is still low, the high time counter must not be enabled. Similarly, the low period of the clock can be stretched by a SMBus master if it is not ready to send or receive data.

### 5.20.3.2 Bus Time Out (Intel® ICH8 as SMBus Master)

If there is an error in the transaction, such that an SMBus device does not signal an acknowledge, or holds the clock lower than the allowed time-out time, the transaction will time out. The ICH8 will discard the cycle and set the DEV\_ERR bit. The time out minimum is 25 ms (800 RTC clocks). The time-out counter inside the ICH8 will start after the last bit of data is transferred by the ICH8 and it is waiting for a response.

The 25 ms timeout counter will not count under the following conditions:

1. BYTE\_DONE\_STATUS bit (SMBus I/O Offset 00h, bit 7) is set
2. The SECOND\_TO\_STS bit (TCO I/O Offset 06h, bit 1) is not set (this indicates that the system has not locked up).

## 5.20.4 Interrupts / SMI #

The ICH8 SMBus controller uses PIRQB# as its interrupt pin. However, the system can alternatively be set up to generate SMI# instead of an interrupt, by setting the SMBUS\_SMI\_EN bit (Device 31:Function 0: Offset 40h:bit 1).

Table 90 and Table 91 specify how the various enable bits in the SMBus function control the generation of the interrupt, Host and Slave SMI, and Wake internal signals. The rows in the tables are additive, which means that if more than one row is true for a particular scenario then the Results for all of the activated rows will occur.



Table 89. Enable for SMBALERT#

Event	INTREN (Host Control I/O Register, Offset 02h, Bit 0)	SMB_SMI_EN (Host Configuration Register, D31:F3:Offset 40h, Bit 1)	SMBALERT_DIS (Slave Command I/O Register, Offset 11h, Bit 2)	Result
SMBALERT# asserted low (always reported in Host Status Register, Bit 5)	X	X	X	Wake generated
	X	1	0	Slave SMI# generated (SMBUS_SMI_STS)
	1	0	0	Interrupt generated

Table 90. Enables for SMBus Slave Write and SMBus Host Events

Event	INTREN (Host Control I/O Register, Offset 02h, Bit 0)	SMB_SMI_EN (Host Configuration Register, D31:F3:Offset 40h, Bit1)	Event
Slave Write to Wake/ SMI# Command	X	X	Wake generated when asleep. Slave SMI# generated when awake (SMBUS_SMI_STS).
Slave Write to SMLINK_SLAVE_SMI Command	X	X	Slave SMI# generated when in the S0 state (SMBUS_SMI_STS)
Any combination of Host Status Register [4:1] asserted	0	X	None
	1	0	Interrupt generated
	1	1	Host SMI# generated

Table 91. Enables for the Host Notify Command

HOST_NOTIFY_INTREN (Slave Control I/O Register, Offset 11h, bit 0)	SMB_SMI_EN (Host Config Register, D31:F3:Off40h, Bit 1)	HOST_NOTIFY_WKEN (Slave Control I/O Register, Offset 11h, bit 1)	Result
0	X	0	None
X	X	1	Wake generated
1	0	X	Interrupt generated
1	1	X	Slave SMI# generated (SMBUS_SMI_STS)



### 5.20.5 SMBALERT#

SMBALERT# is multiplexed with GPIO[11]. When enable and the signal is asserted, The ICH8 can generate an interrupt, an SMI#, or a wake event from S1–S5.

### 5.20.6 SMBus CRC Generation and Checking

If the AAC bit is set in the Auxiliary Control register, the ICH8 automatically calculates and drives CRC at the end of the transmitted packet for write cycles, and will check the CRC for read cycles. It will not transmit the contents of the PEC register for CRC. The PEC bit must not be set in the Host Control register if this bit is set, or unspecified behavior will result.

If the read cycle results in a CRC error, the DEV\_ERR bit and the CRCE bit in the Auxiliary Status register at offset 0Ch will be set.

### 5.20.7 SMBus Slave Interface

The ICH8's SMBus Slave interface is accessed via the SMBus. The SMBus slave logic will not generate or handle receiving the PEC byte and will only act as a Legacy Alerting Protocol device. The slave interface allows the ICH8 to decode cycles, and allows an external microcontroller to perform specific actions. Key features and capabilities include:

- Supports decode of three types of messages: Byte Write, Byte Read, and Host Notify.
- Receive Slave Address register: This is the address that the ICH8 decodes. A default value is provided so that the slave interface can be used without the processor having to program this register.
- Receive Slave Data register in the SMBus I/O space that includes the data written by the external microcontroller.
- Registers that the external microcontroller can read to get the state of the ICH8.
- Status bits to indicate that the SMBus slave logic caused an interrupt or SMI# due to the reception of a message that matched the slave address.
  - Bit 0 of the Slave Status Register for the Host Notify command
  - Bit 16 of the SMI Status Register (Section 9.8.3.15) for all others

**Note:** The external microcontroller should not attempt to access the Intel ICH8's SMBus slave logic until either:

- 800 milliseconds after both: RTCRST## is high and RSMRST# is high, OR
- the PLTRST# de-asserts
- The 800 ms case is based on the scenario where the RTC Battery is dead or missing such that the RTC Power Well comes up simultaneously with Suspend Well. In this case, the RTC clock may take a while to stabilize. The ICH8 uses the RTC clock to extend the internal RSMRST# by ~100 ms. Therefore, if the clock is slow to toggle, this time could be extended. 800 ms is assumed to be sufficient guardband for this.

If a master leaves the clock and data bits of the SMBus interface at 1 for 50  $\mu$ s or more in the middle of a cycle, the ICH8 slave logic's behavior is undefined. This is interpreted as an unexpected idle and should be avoided when performing management activities to the slave logic.

**Note:** When an external microcontroller accesses the SMBus Slave Interface over the SMBus a translation in the address is needed to accommodate the least significant bit used for read/write control. For example, if the ICH8 slave address (RCV\_SLVA) is left at 44h (default), the external micro controller would use an address of 88h/89h (write/read).





### 5.20.7.1 Format of Slave Write Cycle

The external master performs Byte Write commands to the ICH8 SMBus Slave I/F. The “Command” field (bits 11:18) indicate which register is being accessed. The Data field (bits 20:27) indicate the value that should be written to that register.

**Note:** If the ICH8 is sent a ‘Hard Reset Without Cycling’ command on SMBus while the system is in S4 or S5, the reset command and any other write commands accepted by the ICH8 SMBus will not be executed until the next wake event. SMBus write commands that are accepted by the ICH8 are not lost, but completion occurs after the next system wake event. This also applies to any SMBus wake commands accepted after a ‘Hard Reset Without Cycling’ command, such that the SMBus wake command will not cause the system to wake. Any SMBus read that is accepted by the ICH8 will complete normally. Intel® Active Management Technology is not impacted as Intel AMT does not use the Hard Reset Without Cycling command while the system is in S4 or S5.

Table 92 has the values associated with the registers.

**Table 92. Slave Write Registers**

Register	Function
0	Command Register. See Table 93 below for valid values written to this register.
1–3	Reserved
4	Data Message Byte 0
5	Data Message Byte 1
6–7	Reserved
8	Reserved
9–FFh	Reserved

**NOTE:** The external microcontroller is responsible to make sure that it does not update the contents of the data byte registers until they have been read by the system processor. The ICH8 overwrites the old value with any new value received. A race condition is possible where the new value is being written to the register just at the time it is being read. ICH8 will not attempt to cover this race condition (i.e., unpredictable results in this case).



Table 93. Command Types

Command Type	Description
0	Reserved
1	<b>WAKE/SMI#.</b> This command wakes the system if it is not already awake. If system is already awake, an SMI# is generated. <b>NOTE:</b> The SMB_WAK_STS bit will be set by this command, even if the system is already awake. The SMI handler should then clear this bit.
2	<b>Unconditional Powerdown.</b> This command sets the PWRBTNOR_STS bit, and has the same effect as the Powerbutton Override occurring.
3	<b>HARD RESET WITHOUT CYCLING:</b> This command causes a hard reset of the system (does not include cycling of the power supply). This is equivalent to a write to the CF9h register with bits 2:1 set to 1, but bit 3 set to 0.
4	<b>HARD RESET SYSTEM.</b> This command causes a hard reset of the system (including cycling of the power supply). This is equivalent to a write to the CF9h register with bits 3:1 set to 1.
5	<b>Disable the TCO Messages.</b> This command will disable the Intel® ICH8 from sending Heartbeat and Event messages (as described in <a href="#">Section 5.15</a> ). Once this command has been executed, Heartbeat and Event message reporting can only be re-enabled by assertion and deassertion of the RSMRST# signal.
6	<b>WD RELOAD:</b> Reload watchdog timer.
7	Reserved
8	<b>SMLINK_SLV_SMI.</b> When ICH8 detects this command type while in the S0 state, it sets the SMLINK_SLV_SMI_STS bit (see <a href="#">Section 9.9.5</a> ). This command should only be used if the system is in an S0 state. If the message is received during S1–S5 states, the ICH8 acknowledges it, but the SMLINK_SLV_SMI_STS bit does not get set.  <b>NOTE:</b> It is possible that the system transitions out of the S0 state at the same time that the SMLINK_SLV_SMI command is received. In this case, the SMLINK_SLV_SMI_STS bit may get set but not serviced before the system goes to sleep. Once the system returns to S0, the SMI associated with this bit would then be generated. Software must be able to handle this scenario.
9–FFh	Reserved



### 5.20.7.2 Format of Read Command

The external master performs Byte Read commands to the ICH8 SMBus Slave I/F. The “Command” field (bits 18:11) indicate which register is being accessed. The Data field (bits 30:37) contain the value that should be read from that register.

**Table 94. Slave Read Cycle Format**

Bit	Description	Driven by:	Comment:
1	Start	External Microcontroller	
2–8	Slave Address - 7 bits	External Microcontroller	Must match value in Receive Slave Address register.
9	Write	External Microcontroller	Always 0
10	ACK	Intel ICH8	
11–18	Command code – 8 bits	External Microcontroller	Indicates which register is being accessed. See <a href="#">Table 95</a> below for list of implemented registers.
19	ACK	Intel ICH8	
20	Repeated Start	External Microcontroller	
21–27	Slave Address - 7 bits	External Microcontroller	Must match value in Receive Slave Address register
28	Read	External Microcontroller	Always 1
29	ACK	Intel ICH8	
30–37	Data Byte	Intel ICH8	Value depends on register being accessed. <a href="#">Table 95</a> below for list of implemented registers.
38	NOT ACK	External Microcontroller	
39	Stop	External Microcontroller	

**Table 95. Data Values for Slave Read Registers (Sheet 1 of 2)**

Register	Bits	Description
0	7:0	Reserved for capabilities indication. Should always return 00h. Future chips may return another value to indicate different capabilities.
1	2:0	System Power State 000 = S0 001 = S1 010 = Reserved 011 = S3 100 = S4 101 = S5 110 = Reserved 111 = Reserved
	7:3	Reserved
2	3:0	Reserved
	7:4	Reserved
3	5:0	<b>Watchdog Timer current value.</b> Note that Watchdog Timer has 10 bits, but this field is only 6 bits. If the current value is greater than 3Fh, ICH8 will always report 3Fh in this field.
	7:6	Reserved
4	0	1 = The <b>Intruder Detect</b> (INTRD_DET) bit is set. This indicates that the system cover has probably been opened.
	1	1 = BTI <b>Temperature Event</b> occurred. This bit will be set if the Intel ICH8's THRM# input signal is active.

Table 95. Data Values for Slave Read Registers (Sheet 2 of 2)

Register	Bits	Description
	2	<b>DOA CPU Status.</b> This bit will be 1 to indicate that the processor is dead
	3	1 = <b>SECOND_TO_STS</b> bit set. This bit will be set after the second time-out (SECOND_TO_STS bit) of the Watchdog Timer occurs.
	6:4	Reserved. Will always be 0, but software should ignore.
	7	Reflects the value of the GPI[11]/SMBALERT# pin (and is dependent upon the value of the GPI_INV[11] bit. If the GPI_INV[11] bit is 1, then the value in this bit equals the level of the GPI[11]/SMBALERT# pin (high = 1, low = 0). If the GPI_INV[11] bit is 0, then the value of this bit will equal the inverse of the level of the GPI[11]/SMBALERT# pin (high = 0, low = 1).
5	0	<b>FWH bad bit.</b> This bit will be 1 to indicate that the FWH read returned FFh, which indicates that it is probably blank.
	1	<b>Battery Low Status.</b> '1' if the BATLOW# pin is a '0'.
	2	<b>CPU Power Failure Status:</b> '1' if the CPUPWR_FLR bit in the GEN_PMCON_2 register is set.
	3	<b>INIT# due to receiving Shutdown message:</b> This event is visible from the reception of the shutdown message until a platform reset is done if the Shutdown Policy Select bit (SPS) is configured to drive INIT#. When the SPS bit is configured to generate PLTRST# based on shutdown, this register bit will always return 0. Events on signal will not create a event message
	5	<b>POWER_OK_BAD:</b> Indicates the failure core power well ramp during boot/ resume. This bit will be active if the SLP_S3# pin is de-asserted and PWROK pin is not asserted.
	6	<b>Thermal Trip:</b> This bit will shadow the state of CPU Thermal Trip status bit (CTS) (16.2.1.2, GEN_PMCON_2, bit 3). Events on signal will not create a event message
	7	Reserved: Default value is "X" <b>NOTE:</b> Software should not expect a consistent value when this bit is read through SMBUS/SMLINK
6	7:0	Contents of the Message 1 register. See <a href="#">Section 9.9.8</a> for the description of this register.
7	7:0	Contents of the Message 2 register. See <a href="#">Section 9.9.8</a> for the description of this register.
8	7:0	Contents of the WDSTATUS register. See <a href="#">Section 9.9.9</a> for the description of this register.
9 – FFh	7:0	Reserved

### 5.20.7.2.1 Behavioral Notes

According to SMBus protocol, Read and Write messages always begin with a Start bit – Address– Write bit sequence. When the ICH8 detects that the address matches the value in the Receive Slave Address register, it will assume that the protocol is always followed and ignore the Write bit (bit 9) and signal an Acknowledge during bit 10. In other words, if a Start –Address–Read occurs (which is invalid for SMBus Read or Write protocol), and the address matches the ICH8's Slave Address, the ICH8 will still grab the cycle.



Also according to SMBus protocol, a Read cycle contains a Repeated Start–Address–Read sequence beginning at bit 20. Once again, if the Address matches the ICH8's Receive Slave Address, it will assume that the protocol is followed, ignore bit 28, and proceed with the Slave Read cycle.

**Note:** An external microcontroller must not attempt to access the ICH8's SMBus Slave logic until at least 1 second after both RTCRST# and RSMRST# are deasserted (high).

### 5.20.7.3 Format of Host Notify Command

The ICH8 tracks and responds to the standard Host Notify command as specified in the *System Management Bus (SMBus) Specification, Version 2.0*. The host address for this command is fixed to 0001000b. If the ICH8 already has data for a previously-received host notify command which has not been serviced yet by the host software (as indicated by the HOST\_NOTIFY\_STS bit), then it will NACK following the host address byte of the protocol. This allows the host to communicate non-acceptance to the master and retain the host notify address and data values for the previous cycle until host software completely services the interrupt.

**Note:** Host software must always clear the HOST\_NOTIFY\_STS bit after completing any necessary reads of the address and data registers.

Table 96 shows the Host Notify format.

**Table 96. Host Notify Format**

Bit	Description	Driven By	Comment
1	Start	External Master	
8:2	SMB Host Address — 7 bits	External Master	Always 0001_000
9	Write	External Master	Always 0
10	ACK (or NACK)	Intel® ICH8	ICH8 NACKs if HOST_NOTIFY_STS is 1
17:11	Device Address – 7 bits	External Master	Indicates the address of the master; loaded into the Notify Device Address Register
18	Unused — Always 0	External Master	7-bit-only address; this bit is inserted to complete the byte
19	ACK	ICH8	
27:20	Data Byte Low — 8 bits	External Master	Loaded into the Notify Data Low Byte Register
28	ACK	ICH8	
36:29	Data Byte High — 8 bits	External Master	Loaded into the Notify Data High Byte Register
37	ACK	ICH8	
38	Stop	External Master	

## 5.21 Intel® High Definition Audio Overview

The ICH8's controller communicates with the external codec(s) over the Intel High Definition Audio serial link. The controller consists of a set of DMA engines that are used to move samples of digitally encoded data between system memory and an external codec(s). The ICH8 implements four output DMA engines and 4 input DMA engines. The output DMA engines move digital data from system memory to a D-A converter in a codec. ICH8 implements a single Serial Data Output signal (HDA\_SDOUT) that is connected to all external codecs. The input DMA engines move digital data from the A-D converter in the codec to system memory. The ICH8 implements four Serial Digital Input signals (HDA\_SDI[3:0]) supporting up to four codecs.

Audio software renders outbound and processes inbound data to/from buffers in system memory. The location of individual buffers is described by a Buffer Descriptor List (BDL) that is fetched and processed by the controller. The data in the buffers is arranged in a predefined format. The output DMA engines fetch the digital data from memory and reformat it based on the programmed sample rate, bit/sample and number of channels. The data from the output DMA engines is then combined and serially sent to the external codecs over the Intel High Definition Audio link. The input DMA engines receive data from the codecs over the Intel High Definition Audio link and format the data based on the programmable attributes for that stream. The data is then written to memory in the predefined format for software to process. Each DMA engine moves one stream of data. A single codec can accept or generate multiple streams of data, one for each A-D or D-A converter in the codec. Multiple codecs can accept the same output stream processed by a single DMA engine.

Codec commands and responses are also transported to and from the codecs via DMA engines.

### 5.21.1 Intel® High Definition Audio Docking (Mobile Only)

#### 5.21.1.1 Dock Sequence

Note that this sequence is followed when the system is running and a docking event occurs.

1. Since the ICH8 supports docking, the Docking Supported (DCKSTS.DS) bit defaults to a 1. POST BIOS and ACPI BIOS software uses this bit to determine if the HD Audio controller supports docking. BIOS may write a 0 to this RWO bit during POST to effectively turn off the docking feature.
2. After reset in the undocked quiescent state, the Dock Attach (DCKCTL.DA) bit and the Dock Mate (DCKSTS.DM) bit are both de-asserted. The HDA\_DOCK\_EN# signal is de-asserted and HDA\_DOCK\_RST# is asserted. BCLK, SYNC and SDO signals may or may not be running at the point in time that the docking event occurs.
3. The physical docking event is signaled to ACPI BIOS software via ACPI control methods. This is normally done through a GPIO signal on the ICH8 and is outside the scope of this section of the specification.
4. ACPI BIOS software first checks that the docking is supported via DCKSTS.DS=1 and that the DCKSTS.DM=0 and then initiates the docking sequence by writing a 1 to the DCKCTL.DA bit.
5. The HD Audio controller then asserts the HDA\_DOCK\_EN# signal so that the BCLK signal begins toggling to the dock codec. HDA\_DOCK\_EN# shall be asserted synchronously to BCLK and timed such that BCLK is low, SYNC is low, and SDO is low. Pull-down resistors on these signals in the docking station discharge the signals low so that when the state of the signal on both sides of the switch is the same when the switch is turned on. This reduces the potential for charge coupling



glitches on these signals. Note that in the ICH8 the first 8 bits of the Command field are “reserved” and always driven to 0s. This creates a predictable point in time to always assert HDA\_DOCK\_EN#. Note that the HD Audio link reset exit specification that requires that SYNC and SDO be driven low during BCLK startup is not assured. Note also that the SDO and BCLK signals may not be low while HDA\_DOCK\_RST# is asserted which also violates the spec.

6. After the controller asserts HDA\_DOCK\_EN# it waits for a minimum of 2400 BCLKs (100 us) and then de-asserts HDA\_DOCK\_RST#. This is done in such a way to meet the HD Audio link reset exit specification. HDA\_DOCK\_RST# de-assertion should be synchronous to BCLK and timed such that there are least 4 full BCLKS from the de-assertion of HDA\_DOCK\_RST# to the first frame SYNC assertion.
7. The Connect/Turnaround/Address Frame hardware initialization sequence will now occur on the dock codecs' SDI signals. A dock codec is detected when SDI is high on the last BCLK cycle of the Frame Sync of a Connect Frame. The appropriate bit(s) in the State Change Status (STATESTS) register will be set. The Turnaround and Address Frame initialization sequence then occurs on the dock codecs' SDI(s).
8. After this hardware initialization sequence is complete (approximately 32 frames), the controller hardware sets the DCKSTS.DM bit to 1 indicating that the dock is now mated. ACPI BIOS polls the DCKSTS.DM bit and when it detects it is set to 1, conveys this to the OS through a plug-N-play IRP. This eventually invokes the HD Audio Bus Driver, which then begins it's codec discovery, enumeration, and configuration process.
9. Alternatively to step #8, the HD Audio Bus Driver may choose to enable an interrupt by setting the WAKEEN bits for SDINs that didn't originally have codecs attached to them. When a corresponding STATESTS bit gets set an interrupt will be generated. In this case the HD Audio Bus Driver is called directly by this interrupt instead of being notified by the plug-N-play IRP.
10. HD Audio Bus Driver software “discovers” the dock codecs by comparing the bits now set in the STATESTS register with the bits that were set prior to the docking event.

#### 5.21.1.2 Exiting D3/CRST# when Docked

1. In D3/CRST#, CRST# is asserted by the HD Audio Bus Driver. CRST# asserted resets the dock state machines, but does not reset the DCKCTL.DA bit. Because the dock state machines are reset, the dock is electrically isolated (HDA\_DOCK\_EN# de-asserted) and DOCK\_RST# is asserted.
2. The Bus Driver clears the STATESTS bits, then de-asserts CRST#, waits approximately 7ms, then checks the STATESTS bits to see which codecs are present.
3. When CRST# is de-asserted, the dock state machine detects that DCKCTL.DA is still set and the controller hardware sequences through steps to electrically connect the dock by asserting HDA\_DOCK\_EN# and then eventually de-asserts DOCK\_RST#. This completes within the 7 ms mentioned in step 2).
4. The Bus Driver enumerates the codecs present as indicated via the STATESTS bits.
5. Note that this process did not require BIOS or ACPI BIOS to set the DCKCTL.DA bit.

### 5.21.1.3 Cold Boot/Resume from S3 When Docked

1. When booting and resuming from S3, PLTRST# switches from asserted to de-asserted. This clears the DCKCTL.DA bit and the dock state machines. Because the dock state machines are reset, the dock is electrically isolated (HDA\_DOCK\_EN# de-asserted) and DOCK\_RST# is asserted.
2. POST BIOS detects that the dock is attached and sets the DCKCTL.DA bit to 1. Note that at this point CRST# is still asserted so the dock state machine will remain in its reset state.
3. The Bus Driver clears the STATESTS bits, then de-asserts CRST#, waits approximately 7ms, then checks the STATESTS bits to see which codecs are present.
4. When CRST# is de-asserted, the dock state machine detects that DCKCTL.DA is still set and the controller hardware sequences through steps to electrically connect the dock by asserting HDA\_DOCK\_EN# and then eventually de-asserts DOCK\_RST#. This completes within the 7ms mentioned in step 3).
5. The Bus Driver enumerates the codecs present as indicated via the STATESTS bits.

### 5.21.1.4 Undock Sequence

There are two possible undocking scenarios. The first is the one that is initiated by the user that invokes software and gracefully shuts down the dock codecs before they are undocked. The second is referred to as the “surprise undock” where the user undocks while the dock codec is running. Both of these situations appear the same to the controller as it is not cognizant of the “surprise removal”. But both sequences will be discussed here.

#### 5.21.1.4.1 Normal Undock

1. In the docked quiescent state, the Dock Attach (DCKCTL.DA) bit and the Dock Mate (DCKSTS.DM) bit are both asserted. The HDA\_DOCK\_EN# signal is asserted and HDA\_DOCK\_RST# is de-asserted.
2. The user initiates an undock event through the GUI interface or by pushing a button. This mechanism is outside the scope of this section of the document. Either way ACPI BIOS software will be invoked to manage the undock process.
3. ACPI BIOS will call the HD Audio Bus Driver software in order to halt the stream to the dock codec(s) prior to electrical undocking. If the HD Audio Bus Driver is not capable of halting the stream to the docked codec, ACPI BIOS will initiate the hardware undocking sequence as described in the next step while the dock stream is still running. From this standpoint, the result is similar to the “surprise undock” scenario where an audio glitch may occur to the docked codec(s) during the undock process.
4. The ACPI BIOS initiates the hardware undocking sequence by writing a 0 to the DCKCTL.DA bit.
5. The HD Audio controller asserts HDA\_DOCK\_RST#. HDA\_DOCK\_RST# assertion shall be synchronous to BCLK. There are no other timing requirements for HDA\_DOCK\_RST# assertion. Note that the HD Audio link reset specification requirement that the last Frame sync be skipped will not be met.
6. A minimum of 4 BCLKs after HDA\_DOCK\_RST# the controller will de-assert HDA\_DOCK\_EN# to isolate the dock codec signals from the ICH8 HD Audio link signals. HDA\_DOCK\_EN# is de-asserted synchronously to BCLK and timed such that BCLK, SYNC, and SDO are low.
7. After this hardware undocking sequence is complete, the controller hardware clears the DCKSTS.DM bit to 0 indicating that the dock is now un-mated. ACPI BIOS software polls DCKSTS.DM and when it sees DM set, conveys to the end user that physical undocking can proceed. The controller is now ready for a subsequent docking event.





#### 5.21.1.4.2 Surprise Undock

1. In the surprise undock case the user undocks before software has had the opportunity to gracefully halt the stream to the dock codec and initiate the hardware undock sequence.
2. A signal on the docking connector is connected to the switch that isolates the dock codec signals from the ICH8 HD Audio link signals (DOCK\_DET# in the conceptual diagram). When the undock event begins to occur the switch will be put into isolate mode.
3. The undock event is communicated to the ACPI BIOS via ACPI control methods that are outside the scope of this section of the document.
4. ACPI BIOS software writes a 0 to the DCKCTL.DA bit. ACPI BIOS then calls the HD Audio Bus Driver via plug-N-play IRP. The Bus Driver then posthumously cleans up the dock codec stream.
5. The HD Audio controller hardware is oblivious to the fact that a surprise undock occurred. The flow from this point on is identical to the normal undocking sequence described in section 0 starting at step 3). It finishes with the hardware clearing the DCKSTS.DM bit set to 0 indicating that the dock is now un-mated. The controller is now ready for a subsequent docking event.

#### 5.21.1.5 Interaction Between Dock/Undock and Power Management States

When exiting from S3, PLTRST# will be asserted. The POST BIOS is responsible for initiating the docking sequence if the dock is already attached when PLTRST# is de-asserted. POST BIOS writes a 1 to the DCKCTL.DA bit prior to the HD Audio driver de-asserting CRTS# and detecting and enumerating the codecs attached to the HDA\_DOCK\_RST# signal. The HD Audio controller does not directly monitor a hardware signal indicating that a dock is attached. Therefore a method outside the scope of this document must be used to cause the POST BIOS to initiate the docking sequence.

When exiting from D3, CRST# will be asserted. When CRST# bit is "0" (asserted), the DCKCTL.DA bit is not cleared. The dock state machine will be reset such that HDA\_DOCK\_EN# will be de-asserted, HDA\_DOCK\_RST# will be asserted and the DCKSTS.DM bit will be cleared to reflect this state. When the CRST# bit is de-asserted, the dock state machine will detect that DCKCTL.DA is set to "1" and will begin sequencing through the dock process. Note that this does not require any software intervention.

#### 5.21.1.6 Relationship between HDA\_DOCK\_RST# and HDA\_RST#

HDA\_RST# will be asserted when a PLTRST# occurs or when the CRST# bit is 0. As long as HDA\_RST# is asserted, the DOCK\_RST# signal will also be asserted.

When PLTRST# is asserted, the DCKCTL.DA and DCKSTS.DM bits will be get cleared to their default state (0's), and the dock state machine will be reset such that HDA\_DOCK\_EN# will be de-asserted, and HDA\_DOCK\_RST# will be asserted. After any PLTRST#, POST BIOS software is responsible for detecting that a dock is attached and then writing a "1" to the DCKCTL.DA bit prior to the HD Audio Bus Driver de-asserting CRST#.

When CRST# bit is "0" (asserted), the DCKCTL.DA bit is not cleared. The dock state machine will be reset such that HDA\_DOCK\_EN# will be de-asserted, HDA\_DOCK\_RST# will be asserted and the DCKSTS.DM bit will be cleared to reflect this state. When the CRST# bit is de-asserted, the dock state machine will detect that DCKCTL.DA is set to "1" and will begin sequencing through the dock process. Note that this does not require any software intervention.



## 5.22 Intel® Active Management Technology (Intel® AMT) (Intel® ICH8DO and ICH8M-E Only)

Intel Active Management Technology is a set of advanced manageability features developed as a direct result of IT customer feedback gained through Intel market research. Reducing the Total Cost of Ownership (TCO) through improved asset tracking, remote manageability, and fewer desk-side visits were identified as key IT priorities. Intel AMT extends the capabilities of existing management solutions by making the asset information, remote diagnostics, recovery and contain capabilities always available, or Out of Band (OOB), even when the system is in a low-power “off” state or the OS is hung.

Another technology feature of Intel Active Technology is System Defense. System Defense is a Intel AMT feature that is used to stop the propagation of worms and viruses. Programmable packet filters in the integrated LAN Controller are used to accomplish this. These filters inspect all incoming and all outgoing packets and decide whether to block or pass the packets as configured. There is no indication to the host that a packet has been blocked or accepted.

The logic can be used to accept or block reception to host or transmission to network paths. Additionally, counter logic can be used to count the number or filter matches for a given filter. This feature allows for statistical sampling of connections as well as rate limiting of connections.

### 5.22.1 Intel® AMT Features

- E-Asset Tag
- OOB HW and SW Inventory Logs
- OOB Alerts
- IDE Redirect
- Serial over LAN for Remote Control
- Remote Diagnostics Execution
- OS Lock-Up Alert
- OS Repair
- Remote BIOS Recovery and Update

### 5.22.2 Intel® AMT Requirements

Intel AMT is a platform-level solution that utilizes multiple system components including:

- Intel AMT-Ready ICH8 component
- Intel Gigabit Ethernet PHY (Intel® 82566 Gigabit Platform LAN Connect device) with Intel® Active Management Technology for remote access
- SPI flash memory with 4 KB sector erase that meets requirements set in [Section 5.23.2.2](#) (16 Mb minimum for Intel AMT 2.0 (Desktop only) and 32-Mb minimum for Intel AMT 2.5 (Mobile only) to store asset information, management software code, and logs
- BIOS to provide asset detection and POST diagnostics (BIOS and Intel AMT can optionally share same flash memory device)
- Familiar ISV software packages to take advantage of Intel AMT’s platform management capabilities



## 5.23 Serial Peripheral Interface (SPI)

The Serial Peripheral Interface (SPI) is a 4-pin interface that provides a potentially lower-cost alternative for system flash versus the Firmware Hub on the LPC bus.

The 4-pin SPI interface consists of clock (CLK), master data out (Master Out Slave In (MOSI)), master data in (Master In Slave Out (MISO)) and an active low chip select (CS#).

The ICH8 supports two SPI flash devices using two separate Chip Select pins. Each SPI flash device can be up to 16 MBytes. The ICH8 SPI interface supports 20 MHz and 33 MHz SPI devices.

Communication on the SPI bus is done with a Master – Slave protocol. The Slave is connected to the ICH8 and is implemented as a tri-state bus.

**Note:** When SPI is selected by the Boot BIOS Destination Strap and a SPI device is detected by the ICH8, LPC based BIOS flash is disabled.

### 5.23.1 SPI Supported Feature Overview

SPI Flash on the ICH8 has two operational modes, descriptor and non-descriptor. Non-descriptor mode is similar to flash functionality of Intel® ICH7. In this mode, SPI Flash can only be used for BIOS. Direct read and writes are not supported. BIOS has read/write access only through register accesses. Through those register accesses BIOS can read and write to the entire flash without security checking. There is also no support for the integrated GbE, Manageability Engine, chipset soft straps, as well multiple SPI Flash components.

Descriptor Mode enables many new features of the chipset

- Integrated GbE and Host CPU for GbE Software
- Intel Active Management Technology (ICH8DO and ICH8M-E Only)
- Intel® Quiet System Technology (Desktop Only)
- Supports two SPI Flash components using two separate chip select pins
- Hardware enforced security restricting master accesses to different regions
- Chipset Soft Strap region provides the ability to use Flash NVM as an alternative to hardware pull-up/pull-down resistors for both ICH and MCH
- Supports the SPI Fast Read instruction and frequencies of 33 MHz
- Uses standardized Flash Instruction Set

In Descriptor Mode the Flash is divided into four separate regions:

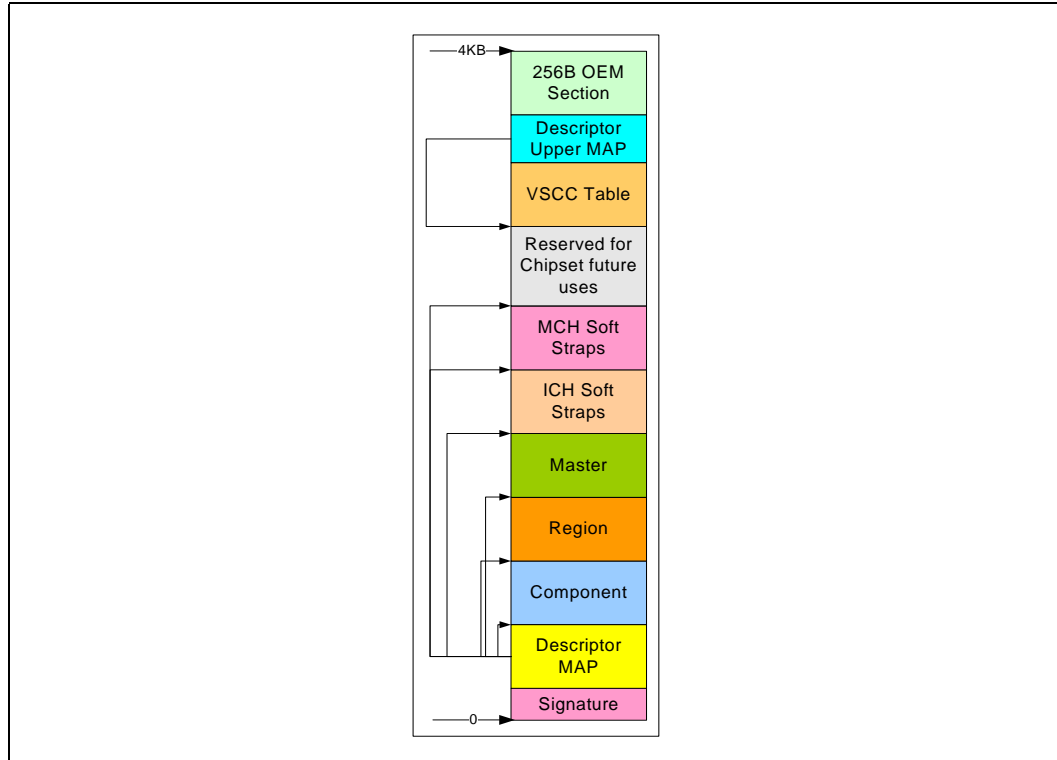
Region	Content
0	Flash Descriptor
1	BIOS
2	ME
3	GbE

Only three masters can access the four regions: Host CPU running BIOS code, Integrated GbE and Host CPU running GbE Software, and ME. The Flash Descriptor is requires one 4KB Block/Sector. The Integrated GbE needs two 4KB Blocks/Sectors. BIOS and the Manageability Engine (ME) are the other two regions. The only required region is Region 0, the Flash Descriptor. Region 0 must be located in the first sector of component 0 (offset 0).

### 5.23.1.1 Flash Descriptor

The maximum size of the Flash Descriptor is one 4KB block. The information stored in the Flash Descriptor can only be written during the manufacturing process as its read/write permissions must be set to Read only when the computer leaves the manufacturing floor. The Flash Descriptor is broken up into six sections:

Figure 17. Flash Descriptor



The Flash signature as mentioned before is what selects Descriptor Mode as well as verifying if the flash is programmed and functioning. The data at the bottom of the flash (offset 0) must be 0FF0A55Ah in order to be in Descriptor mode. The Descriptor map has pointers to the other six descriptor sections as well as the size of each. The component section has information about the SPI flash in the system. It has number of components, density of each, invalid instructions (such as chip erase), and frequencies for read, fast read and write/erase instructions. The Region section points to the three other regions as well as the size of each region. The master region contains the security settings for the flash, granting read/write permissions for each region and identifying each master. The MCH and ICH chipset soft strap sections contain MCH and ICH configurable parameters. The Reserved for Chipset Future uses region between the top of the MCH strap section and the bottom of the VSCC Table is reserved for future uses or growth of the existing sections by the chipset. The Descriptor Upper Map is 256B below the 4KB boundary of the descriptor. This determines the length and base address of the VSCC Table. The VSCC Table holds the JEDEC ID and the VSCC information of all the SPI Flash supported by that NVM image. The JEDEC and VSCC information is necessary to allow devices that meet the compatibility requirements in [Section 5.23.2.2](#) to work with Intel® AMT, ASF, and/or Intel® Quiet Technology. 256B is reserved at the top of the Flash Descriptor for use by OEM.



### 5.23.1.2 Flash Access

There are two types of flash accesses:

Direct Access:

- Masters are allowed to do direct read only of their primary region
  - GbE region can only be directly accessed by the GbE controller. GbE software must use Program Registers to access the GbE region.
- Master's Host or ME virtual read address is converted into the SPI Flash Linear Address (FLA) using the Flash Descriptor Region Base/Limit registers

Program Register Access:

- Program Register Accesses are not allowed to cross a 4KB boundary and can not issue a command that might extend across two components
- Software programs the FLA corresponding to the region desired
  - Software must read the device's Primary Region Base/Limit address to create a FLA.

### 5.23.1.3 Program Register Software Sequencing

- Supported in Descriptor and Non-Descriptor Mode
- Software has full control over the SPI op codes and transactions
  - Same behavior as ICH7
  - Additional registers such as SPI Cycle Frequency and Fast Read have been added in ICH8
- Primary use of software sequencing is when using non-standard instructions and as a backup to hardware sequencing.

### 5.23.1.4 Direct Access Security

- "Requester ID of the device must match that of the primary Requester ID in the Master Section
- "Calculated Flash Linear Address must fall between primary region base/limit
- "Direct Write not allowed
- "Direct Read Cache contents are reset to 0's on a read from a different master
  - Supports the same cache flush mechanism in ICH7 which includes Program Register Writes

### 5.23.1.5 Register Access Security

- Only primary region masters can access the registers  
Note: Processor running GbE software can access GbE registers
- Masters are only allowed to read or write those regions they have read/write permission
- Using the Flash Region Access Permissions, one master can give another master read/write permissions to their area
- Using the five Protected Range registers, each master can add separate read/write protection above that granted in the Flash Descriptor for their own accesses
  - Example: BIOS may want to protect different regions of BIOS from being erased
  - Ranges can extend across region boundaries



## 5.23.2 SPI Device Compatibility Requirements

A variety of SPI flash devices exist in the market. In order for a SPI device to be compatible with the ICH8 it must meet the minimum requirements detailed in the following sections.

### 5.23.2.1 Device Requirements for System BIOS Storage Only

A serial flash device must meet the following minimum requirements when used explicitly for system BIOS storage.

- Erase size capability of at least one of the following: 64 Kbytes, 4 Kbytes, or 256 bytes.
  - If two serial flash devices will be used, they must have the same erase size capabilities and opcodes.
- Required command set and associated opcodes (Refer to [Section 5.23.3.1](#)).
- JEDEC ID Device identification command (Refer to [Section 5.23.3.3](#)).
- Device must support multiple writes to a page without requiring a preceding erase cycle (Refer to [Section 5.23.3.4](#)).
- Serial flash device must ignore the upper address bits such that an address of FFFFFFFh simply aliases to the top of the flash memory.
- SPI Compatible Mode 0 support (clock phase is 0 and data is latched on the rising edge of the clock).
- If the device receives a command that is not supported, the device must complete the cycle gracefully without any impact on the flash content.
- An erase command (page, sector, block, chip, etc.) must set to 1 (FFh) all bits inside the designated area (page, sector, block, chip, etc.).
- Minimum density of 4 Mbit (Platform dependent based on size of BIOS).

### 5.23.2.2 Device Requirements for Intel® AMT, ASF and AFSC Firmware

ICH8 has added the capability that a single SPI flash device can be used to store system BIOS, Intel

AMT Firmware and GbE EEPROM information. This unified flash configuration for system BIOS

and Intel AMT firmware must meet the following minimum requirements to be compatible with the ICH8:

The following are requirements that are in common with System BIOS only configuration as listed in [Section 5.23.2.1](#):



The following is a list of additional requirements specific to configurations 2 and 3:

- 4 Kbytes erase size must be supported.
- Flash device must power up in an unlocked state (no write protection) or use the write status register to disable write protection. If the write status register must be unprotected, it must use the enable write status register command 50h or write enable 06h. Opcode 01h must then be used to write 00h into the write status register. This must unlock the entire part. If there is no need to write enable the write status register, then 06h and 50h must be ignored.
- Byte write must be supported.
  - The flexibility to perform a write between 1 byte to 256 bytes is recommended
- A serial flash device that requires the Write Enable command must automatically clear the Write Enable Latch at the end of Data Program instructions.
- Status Register bit 0 must be set to 1 when a write or erase is in progress and cleared to 0 when a write or erase is NOT in progress.
- Minimum density of AFSC + BIOS is 8 Mb
- Minimum density of ASF + BIOS is 8 Mb
- Minimum density of Intel® AMT 2.0 (Desktop Only)+BIOS+GbE is 16 Mb;  
Minimum density of Intel AMT 2.5 (Mobile Only) + BIOS +GbE is 32 Mb.

### 5.23.2.3 Device Requirements for GbE

A serial flash device that will be used for both system BIOS and GbE on the same device must meet the minimum compatibility requirements detailed in [Section 5.23.2.1](#)

## 5.23.3 Serial Flash Command Set

### 5.23.3.1 Required Command Set for Interoperability

The following table contains a list of commands and the associated opcodes that a SPI-based serial flash device must support in order to be interoperable with the Intel Serial Peripheral Interface.

**Table 97. Required Commands and Opcodes**

Commands	OPCODE	Notes
Write Status	01h	If command is supported, 01h must be the opcode.
Program Data	02h	Write Data / Program Data
Read Data	03h	
Write Disable	04h	
Read Status	05h	
Write Enable	06h	If command is supported, 06h must be the opcode.
Fast Read	0Bh	
Enable Write Status	50h	If Write status register must be unlocked it must use this opcode or Write Enable.
Erase	Programmable	Size and opcode programmed in the VSSC Register
JEDEC ID	9Fh	Refer to <a href="#">Section 5.23.3.3</a>



### 5.23.3.2 Recommended Command Set and Opcodes

The following table lists recommended opcodes for serial flash commands. Using a command specified below, with the associated opcode, will allow software developers to streamline their code and will aid in minimizing latencies.

Table 98. Recommended Command and Opcode Associations

Commands	OPCODE	Notes
Full Chip Erase	C7h	

### 5.23.3.3 JEDEC Device Identification

Since each serial flash device may have unique capabilities and commands, the JEDEC ID is the necessary mechanism for identifying the device so the uniqueness of the device can be comprehended by the controller (master). The JEDEC ID uses the opcode 9Fh and a specified implementation and usage model. This JEDEC Standard Manufacturer and Device ID read method is defined in Standard JESD21-C, PRN03-NV1 and is available on the JEDEC website: [www.jedec.org](http://www.jedec.org).

### 5.23.3.4 Multiple Page Write Usage Model

The system BIOS and Intel® Active Management Technology firmware usage models require that the serial flash device support multiple writes (minimum of 512 writes) to a page (256 bytes) without requiring a preceding erase command. BIOS commonly uses capabilities such as counters that are typically implemented by using byte writes to 'increment' the bits within a page that have been designated as the counter. The Intel AMT firmware usage model requires the capability for multiple data updates within any given page. These data updates occur via byte writes without executing a preceding erase to the given page. Both the BIOS and Intel AMT firmware multiple page write usage models apply to sequential and non-sequential data writes.

**Note:** This usage model requirement is based on any given bit only being written once from a '1' to a '0' without requiring the preceding erase. An erase would be required to change bits back to the '1' state.





## 5.24 Intel<sup>®</sup> Quiet System Technology (Desktop Only)

The ICH8 implements three PWM and 4 TACH signals for fan speed control.

**Note:** Intel<sup>®</sup> Quiet System Technology functionality requires a correctly configured system, including an appropriate (G)MCH with ME, ME Firmware, and system BIOS support.

### 5.24.1 PWM Outputs

This signal is driven as open-drain. An external pull-up resistor is integrated into the fan to provide the rising edge of the PWM output signal. The PWM output is driven low during reset, which represents 0% duty cycle to the fans. After reset de-assertion, the PWM output will continue to be driven low until one of the following occurs:

- The internal PWM control register is programmed to a non-zero value by the AFSC firmware
- The watchdog timer expires (enabled and set at 4 seconds by default).
- The polarity of the signal is inverted by the Intel Quiet System Technology firmware

Note that if a PWM output will be programmed to inverted polarity for a particular fan, then the low voltage driven during reset represents 100% duty cycle to the fan.

### 5.24.2 TACH Inputs

This signal is driven as an open-collector or open-drain output from the fan. An external pull-up is expected to be implemented on the motherboard to provide the rising edge of the TACH input. This signal has analog hysteresis and digital filtering due to the potentially slow rise and fall times. This signal has a weak internal pull-up resistor to keep the input buffer from floating if the TACH input is not connected to a fan.

## 5.25 Thermal Sensors

ICH8 integrates two thermal sensors that monitor the temperature within its die. The thermal sensors are used for Intel Quiet System Technology. The AFSC firmware can internally access the temperature measured by the sensors and use the data as a factor to determine how to control the fans.

The ICH8 thermal sensors also provide the capability to protect the ICH8 under a catastrophic thermal situation. When the sensors are enabled and correctly programmed by the system BIOS, the ICH8 will shut down the system when the ICH8 thermal limit is reached. Refer to the Thermal Memory Mapped Configuration Registers (Section 20.2) for more information on the catastrophic settings.



## 5.26 Intel® Quick Resume Technology (Intel® ICH8DH Only)

ICH8DH implements the following Intel Quick Resume Technology features:

- Visual Off
- Consumer Electronics (CE) like On/Off

### 5.26.1 5.26.1 Visual Off

Intel Quick Resume Technology provides a new functional state called Visual Off. In Visual Off the PC appears to be Off but is actually active and able to run program tasks. The Visual Off state is transparent to the user. It is entered by simply pressing the power button when the system is On. This turns off the display, sound, front panel lights and HID devices (e.g. keyboard and mouse) but the PC stays active. Perceptually to the user, the system appears Off in this state. Pressing the power button again will turn back On the perceptual components that were “muted” in Visual Off.

From the Visual Off state, the system's power management can place the PC in a low power suspend state (S3) using existing mechanisms. Again, this is transparent to the end user.

### 5.26.2 5.26.2 CE-like On/Off

Intel Quick Resume Technology redefines the PC's power button behavior to switch between user perceived On and Off states like a consumer electronics (CE) device. For example when a television is turned off there is no shutdown procedure. The viewer simply turns it Off. Likewise when a modern television is turned On it returns to the same channel, volume level, color balance, etc. as when it was turned Off. Intel Quick Resume Technology gives the PC this similar functionality. A simple press of the power button turns it On or Off. There is no user visible lengthy boot up or shutdown process as the Visual Off state is used. Therefore, there is no need to exit running applications.

Just as televisions may have multiple power buttons (e.g. on the TV and on a remote control) so may the PC (e.g. a power button on the system unit and another on the keyboard). However all power buttons behave the same - On/Off. The PC will not turn On (wake up) when any key is pressed or the mouse moved just as pressing the volume button or TV channel button does not cause the TV to turn On. Only a power button press turns it On and Off.

### 5.26.3 Intel® Quick Resume Technology Signals

To provide the end user notification of the system power state, it is recommended that the front panel LED be used to indicate Visual Off in the same way that the front panel LED is used to indicate the S3 system state. For example, if in the S3 state the front panel LED is solid amber, also set the front panel LED to be solid amber upon entrance into Visual Off.

To provide for platform implementation flexibility, the ICH8 implements two Intel Quick Resume Technology signals which are multiplexed with GPIOs: QRT\_STATE0/GPIO27 and QRT\_STATE1/GPIO28. The QRT\_STATE[1:0] pins may be used to control LED(s) to provide end-user notification of the current system state or may be used as GPIO pins (independently or combined). See section 14 for further details on controlling these signals.



## 5.26.4 Power Button Sequence

When Intel Quick Resume Technology is enabled and the user presses the PWRBTN# to indicate a desire to put the system into the Visual Off state, the following sequence is assumed:

1. User presses the Power Button, which causes the PWRBTN# signal to go low.
2. Intel Quick Resume Technology logic sets the EL\_PB\_STS bit. If the PWRBTN\_INT\_EN bit is set, the ICH8 does NOT set the PWRBTN\_STS bit at this point.
3. Intel Quick Resume Technology logic causes an SMI or SCI (depending on the SMI\_OPTION\_CNT bit.)
4. If the Intel Quick Resume Technology logic was set to cause an SMI, the SMI handler executes and then sets the SCI\_NOW\_CNT bit.
5. The Intel Quick Resume Technology SCI handler executes.
6. The Intel Quick Resume Technology SCI handler needs to cause the PWRBTN\_STS bit to be set, it can do so by setting the PWRBTN\_EVENT bit.

**Note:** When PWRBTN\_STS is set, the ICH8 causes an SCI and the normal OS handler for PWRBTN\_STS is called.

## 5.27 Feature Capability Mechanism

A new set of registers have been added into ICH8 LPC Interface (Device 31, Function 0, offset E0h – EBh) that allows the system software or BIOS to easily determine the features supported by ICH8. These registers can be accessed through LPC PCI configuration space, thus allowing for convenient single point access mechanism for chipset feature detection.

This set of registers consists of:

- Capability ID (FDCAP)
- Capability Length (FDLEN)
- Capability Version and Vendor-Specific Capability ID (FDVER)
- Feature Vector (FVECT)

## 5.28 Serial POST Codes Over GPIO

ICH8 adds the extended capability allowing system software to serialize POST or other messages on GPIO. This capability negates the requirement for dedicated diagnostic LEDs on the platform. Additionally, based on the newer BTX form factors, the PCI bus as a target for POST codes is increasingly difficult to support as the total number of PCI devices supported are decreasing.

### 5.28.1 Theory of operation

For the ICH8, generation POST code serialization logic will be shared with GPIO. These GPIO will likely be shared with LED control offered by the Super I/O (SIO) component.

The anticipated usage model is that either the ICH8 or the SIO can drive a pin low to turn off an LED. In the case of the power LED, the SIO would normally leave its corresponding pin in a high-Z state to allow the LED to turn on. In this state, the ICH8 can blink the LED by driving its corresponding pin low and subsequently tri-stating the buffer.

An external optical sensing device can detect the on/off state of the LED. By externally post-processing the information from the optical device, the serial bit stream can be recovered. The hardware will supply a 'sync' byte before the actual data transmission to allow external detection of the transmit frequency. The frequency of transmission should be limited to 1 transition every 1usec to ensure the detector can reliably sample the on/off state of the LED. To allow flexibility in pull-up resistor values for power optimization, the frequency of the transmission is programmable via the DRS field in the GP\_SB\_CMDSTS register (See [Section 9.10.7](#)).

The serial bit stream is Manchester encoded. This choice of transmission ensures that a transition will be seen on every clock. The 1 or 0 data is based on the transmission happening during the high or low phase of the clock.

A simplified hardware/software register interface provides control and status information to track the activity of this block. Software enabling the serial blink capability should implement an algorithm referenced below to send the serialized message on the enabled GPIO.

1. Read the Go/Busy status bit in the GP\_SB\_CMDSTS register and verify it is cleared. This will ensure that the GPIO is idled and a previously requested message is still not in progress.
2. Write the data to serialize into the GP\_SB\_DATA register.
3. Write the DLS and DRS values into the GP\_SB\_CMDSTS register and set the Go bit. This may be accomplished using a single write.

By providing a generic capability that can be used both in the main and the suspend power planes, maximum flexibility can be achieved. A key point to make is that the ICH8 will not unintentionally drive the LED control pin low unless a serialization is in progress. System board connections using this serialization capability are required to use the same power plane controlling the LED as the ICH8 GPIO pin. Otherwise, the ICH8 GPIO may float low during the message and prevent the LED from being controlled from the SIO. The hardware will only be serializing messages when the core power well is powered and the processor is operational.

Care should be taken to prevent the ICH8 from driving an active '1' on a pin sharing the serial LED capability. Since the SIO could be driving the line to 0, having the ICH8 drive a 1 would create a high current path. A recommendation to avoid this condition involves choosing a GPIO defaulting to an input. The GP\_SER\_BLINK register (See



Section 9.10.7) should be set first before changing the direction of the pin to an output. This sequence ensures the open-drain capability of the buffer is properly configured before enabling the pin as an output.

### 5.28.2 Serial Message Format

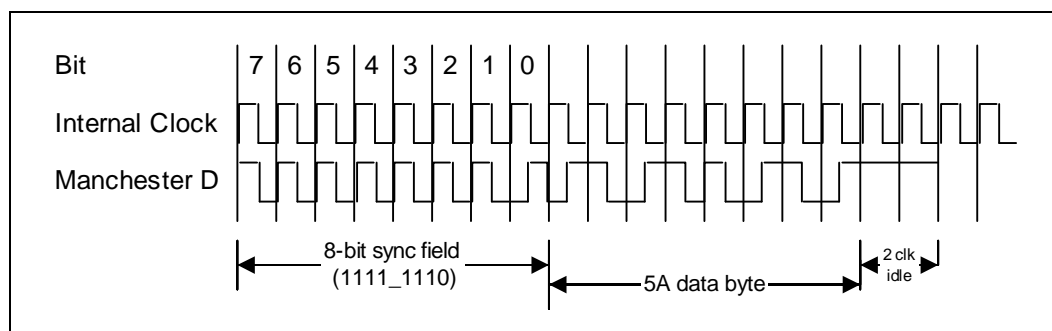
To serialize the data onto the GPIO, an initial state of hi-Z is assumed. The SIO is required to have its LED control pin in a high-Z state as well to allow ICH8 to blink the LED.

The three components of the serial message include the sync, data, and idle fields. The sync field is 7 bits of '1' data followed by 1 bit of '0' data. Starting from the hi-Z state (LED on) provides external hardware a known initial condition and a known pattern. In case one or more of the leading 1 sync bits are lost, the 1's followed by 0 provide a clear indication of 'end of sync'. This pattern will be used to 'lock' external sampling logic to the encoded clock.

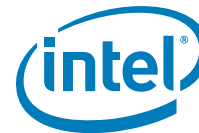
The data field is shifted out with the highest byte first (MSB). Within each byte, the most significant bit is shifted first (MSb).

The idle field is enforced by the hardware and is at least 2 bit times long. The hardware will not clear the Busy and Go bits until this idle time is met. Supporting the idle time in hardware prevents time-based counting in BIOS as the hardware is immediately ready for the next serial code when the Go bit is cleared. Note that the idle state is represented as a high-Z condition on the pin. If the last transmitted bit is a '1', returning to the idle state will result in a final 0-1 transition on the output Manchester data. Two full bit times of idle correspond to a count of 4 time intervals (the width of the time interval is controlled by the DRS field).

The waveform below shows a 1-byte serial write with a data byte of 5Ah. The internal clock and bit position are for reference purposes only. The Manchester D is the resultant data generated and serialized onto the GPIO. Since the buffer is operating in open-drain mode the transitions are from hi-Z to 0 and back.







## 6 Register and Memory Mapping

The ICH8 contains registers that are located in the processor's I/O space and memory space and sets of PCI configuration registers that are located in PCI configuration space. This chapter describes the ICH8 I/O and memory maps at the register-set level. Register access is also described. Register-level address maps and Individual register bit descriptions are provided in the following chapters. The following notations and definitions are used in the register/instruction description chapters.

<b>RO</b>	Read Only. In some cases, If a register is read only, writes to this register location have no effect. However, in other cases, two separate registers are located at the same location where a read accesses one of the registers and a write accesses the other register. See the I/O and memory map tables for details.
<b>WO</b>	Write Only. In some cases, If a register is write only, reads to this register location have no effect. However, in other cases, two separate registers are located at the same location where a read accesses one of the registers and a write accesses the other register. See the I/O and memory map tables for details.
<b>R/W</b>	Read/Write. A register with this attribute can be read and written.
<b>R/WC</b>	Read/Write Clear. A register bit with this attribute can be read and written. However, a write of 1 clears (sets to 0) the corresponding bit and a write of 0 has no effect.
<b>R/WO</b>	Read/Write-Once. A register bit with this attribute can be written only once after power up. After the first write, the bit becomes read only.
<b>R/WLO</b>	Read/Write, Lock-Once. A register bit with this attribute can be written to the non-locked value multiple times, but to the locked value only once. After the locked value has been written, the bit becomes read only.
<b>Default</b>	When ICH8 is reset, it sets its registers to predetermined default states. The default state represents the minimum functionality feature set required to successfully bring up the system. Hence, it does not represent the optimal system configuration. It is the responsibility of the system initialization software to determine configuration, operating parameters, and optional system features that are applicable, and to program the ICH8 registers accordingly.
<b>Bold</b>	Register bits that are highlighted in bold text indicate that the bit is implemented in the ICH8. Register bits that are not implemented or are hardwired will remain in plain text.

### 6.1 PCI Devices and Functions

The Intel ICH8 incorporates a variety of PCI devices and functions, as shown in [Table 99](#). They are divided into seven logical devices. The first is the DMI-To-PCI bridge (Device 30). The second device (Device 31) contains most of the standard PCI functions that always existed in the PCI-to-ISA bridges (South Bridges), such as the Intel PIIX4 or Intel PIIX6. The third and fourth (Device 29 and Device 26) are the USB



(and USB2) host controller devices. The fifth (Device 28) is PCI Express device. The sixth (Device 27) is HD Audio controller device, and the seventh (Device 25) is the GbE controller device.

If for some reason, the particular system platform does not want to support any one of the Device Functions, with the exception of D30:F0, they can individually be disabled. The integrated LAN controller will be disabled if no Platform LAN Connect component is detected (See Chapter 5.3). When a function is disabled, it does not appear at all to the software. A disabled function will not respond to any register reads or writes, insuring that these devices appear hidden to software.

**Table 99. PCI Devices and Functions**

Bus:Device:Function	Function Description
Bus 0:Device 30:Function 0	PCI-to-PCI Bridge
Bus 0:Device 31:Function 0	LPC Controller <sup>1</sup>
Bus 0:Device 31:Function 1	IDE Controller
<b>Bus 0:Device 31:Function 2</b>	<b>SATA Controller #1</b>
Bus 0:Device 31:Function 3	SMBus Controller
Bus 0:Device 31:Function 5	SATA Controller #2
Bus 0:Device 31:Function 6	Thermal Subsystem
Bus 0:Device 29:Function 0	USB UHCI Controller #1
Bus 0:Device 29:Function 1	USB UHCI Controller #2
Bus 0:Device 29:Function 2	USB UHCI Controller #3
Bus 0:Device 29:Function 3	USB UHCI Controller #4 <sup>2</sup>
Bus 0:Device 26:Function 0	USB1.1 UHCI Controller #4 <sup>2</sup>
Bus 0:Device 26:Function 1	USB1.1 UHCI Controller #5
Bus 0:Device 29:Function 7	USB 2.0 EHCI Controller #1
Bus 0:Device 26:Function 7	USB2 EHCI Controller #2
Bus 0:Device 28:Function 0	PCI Express* Port 1
Bus 0:Device 28:Function 1	PCI Express Port 2
Bus 0:Device 28:Function 2	PCI Express Port 3
Bus 0:Device 28:Function 3	PCI Express Port 4
Bus 0:Device 28:Function 4	PCI Express Port 5
Bus 0:Device 28:Function 5	PCI Express Port 6
Bus 0:Device 27:Function 0	Intel® High Definition Audio Controller
Bus 0:Device 25:Function 0	GbE Controller

**NOTES:**

1. The PCI-to-LPC bridge contains registers that control LPC, Power Management, System Management, GPIO, Processor Interface, RTC, Interrupts, Timers, and DMA
2. When USB ports 9, 10 and EHCI controller #2 are disabled, the UHCI host controller #4 will be mapped to D29:F3. Otherwise, it will be mapped to D26:F0.





## 6.2 PCI Configuration Map

Each PCI function on the ICH8 has a set of PCI configuration registers. The register address map tables for these register sets are included at the beginning of the chapter for the particular function.

Configuration Space registers are accessed through configuration cycles on the PCI bus by the Host bridge using configuration mechanism #1 detailed in the *PCI Local Bus Specification, Revision 2.3*.

Some of the PCI registers contain reserved bits. Software must deal correctly with fields that are reserved. On reads, software must use appropriate masks to extract the defined bits and not rely on reserved bits being any particular value. On writes, software must ensure that the values of reserved bit positions are preserved. That is, the values of reserved bit positions must first be read, merged with the new values for other bit positions and then written back. Note the software does not need to perform read, merge, write operation for the configuration address register.

In addition to reserved bits within a register, the configuration space contains reserved locations. Software should not write to reserved PCI configuration locations in the device-specific region (above address offset 3Fh).

## 6.3 I/O Map

The I/O map is divided into Fixed and Variable address ranges. Fixed ranges cannot be moved, but in some cases can be disabled. Variable ranges can be moved and can also be disabled.

### 6.3.1 Fixed I/O Address Ranges

Table 100 shows the Fixed I/O decode ranges from the processor perspective. Note that for each I/O range, there may be separate behavior for reads and writes. DMI (Direct Media Interface) cycles that go to target ranges that are marked as "Reserved" will not be decoded by the ICH8, and will be passed to PCI unless the Subtractive Decode Policy bit is set (D31:F0:Offset 42h, bit 0). If a PCI master targets one of the fixed I/O target ranges, it will be positively decoded by the ICH8 in medium speed.

Refer to Table 100 for a complete list of all fixed I/O registers. Address ranges that are not listed or marked "Reserved" are **not** decoded by the ICH8 (unless assigned to one of the variable ranges).



Table 100. Fixed I/O Ranges Decoded by Intel® ICH8 (Sheet 1 of 2)

I/O Address	Read Target	Write Target	Internal Unit
00h–08h	DMA Controller	DMA Controller	DMA
09h–0Eh	RESERVED	DMA Controller	DMA
0Fh	DMA Controller	DMA Controller	DMA
10h–18h	DMA Controller	DMA Controller	DMA
19h–1Eh	RESERVED	DMA Controller	DMA
1Fh	DMA Controller	DMA Controller	DMA
20h–21h	Interrupt Controller	Interrupt Controller	Interrupt
24h–25h	Interrupt Controller	Interrupt Controller	Interrupt
28h–29h	Interrupt Controller	Interrupt Controller	Interrupt
2Ch–2Dh	Interrupt Controller	Interrupt Controller	Interrupt
2E–2F	LPC SIO	LPC SIO	Forwarded to LPC
30h–31h	Interrupt Controller	Interrupt Controller	Interrupt
34h–35h	Interrupt Controller	Interrupt Controller	Interrupt
38h–39h	Interrupt Controller	Interrupt Controller	Interrupt
3Ch–3Dh	Interrupt Controller	Interrupt Controller	Interrupt
40h–42h	Timer/Counter	Timer/Counter	PIT (8254)
43h	RESERVED	Timer/Counter	PIT
4E–4F	LPC SIO	LPC SIO	Forwarded to LPC
50h–52h	Timer/Counter	Timer/Counter	PIT
53h	RESERVED	Timer/Counter	PIT
60h	Microcontroller	Microcontroller	Forwarded to LPC
61h	NMI Controller	NMI Controller	Processor I/F
62h	Microcontroller	Microcontroller	Forwarded to LPC
64h	Microcontroller	Microcontroller	Forwarded to LPC
66h	Microcontroller	Microcontroller	Forwarded to LPC
70h	RESERVED	NMI and RTC Controller	RTC
71h	RTC Controller	RTC Controller	RTC
72h	RTC Controller	NMI and RTC Controller	RTC
73h	RTC Controller	RTC Controller	RTC
74h	RTC Controller	NMI and RTC Controller	RTC
75h	RTC Controller	RTC Controller	RTC
76h	RTC Controller	NMI and RTC Controller	RTC
77h	RTC Controller	RTC Controller	RTC
80h	DMA Controller, or LPC, or PCI	DMA Controller and LPC or PCI	DMA
81h–83h	DMA Controller	DMA Controller	DMA
84h–86h	DMA Controller	DMA Controller and LPC or PCI	DMA
87h	DMA Controller	DMA Controller	DMA



Table 100. Fixed I/O Ranges Decoded by Intel® ICH8 (Sheet 2 of 2)

I/O Address	Read Target	Write Target	Internal Unit
88h	DMA Controller	DMA Controller and LPC or PCI	DMA
89h–8Bh	DMA Controller	DMA Controller	DMA
8Ch–8Eh	DMA Controller	DMA Controller and LPC or PCI	DMA
08Fh	DMA Controller	DMA Controller	DMA
90h–91h	DMA Controller	DMA Controller	DMA
92h	Reset Generator	Reset Generator	Processor I/F
93h–9Fh	DMA Controller	DMA Controller	DMA
A0h–A1h	Interrupt Controller	Interrupt Controller	Interrupt
A4h–A5h	Interrupt Controller	Interrupt Controller	Interrupt
A8h–A9h	Interrupt Controller	Interrupt Controller	Interrupt
ACh–ADh	Interrupt Controller	Interrupt Controller	Interrupt
B0h–B1h	Interrupt Controller	Interrupt Controller	Interrupt
B2h–B3h	Power Management	Power Management	Power Management
B4h–B5h	Interrupt Controller	Interrupt Controller	Interrupt
B8h–B9h	Interrupt Controller	Interrupt Controller	Interrupt
BCh–BDh	Interrupt Controller	Interrupt Controller	Interrupt
C0h–D1h	DMA Controller	DMA Controller	DMA
D2h–DDh	RESERVED	DMA Controller	DMA
DEh–DFh	DMA Controller	DMA Controller	DMA
F0h	PCI and Master Abort <sup>1</sup>	FERR#/IGNNE# / Interrupt Controller	Processor I/F
170h–177h	IDE Controller (Mobile only), SATA Controller, or PCI	IDE Controller (Mobile only), SATA Controller, or PCI	Forwarded to IDE (Mobile only) or SATA
1F0h–1F7h	IDE Controller (Mobile only), SATA Controller, or PCI2	IDE Controller (Mobile only), SATA Controller, or PCI	Forwarded to IDE (Mobile only) or SATA
376h	IDE Controller (Mobile only), SATA Controller, or PCI	IDE Controller (Mobile only), SATA Controller, or PCI	Forwarded to IDE (Mobile only) or SATA
3F6h	IDE Controller (Mobile only), SATA Controller, or PCI 2	IDE Controller (Mobile only), SATA Controller, or PCI	Forwarded to IDE (Mobile only) or SATA
4D0h–4D1h	Interrupt Controller	Interrupt Controller	Interrupt
CF9h	Reset Generator	Reset Generator	Processor I/F

**NOTES:**

1. A read to this address will subtractively go to PCI, where it will master abort.
2. Mobile Only: Only if IDE I/O space is enabled (D31:F1:40 bit 15) and the IDE controller is in legacy mode. Otherwise, the target is PCI.



### 6.3.2 Variable I/O Decode Ranges

Table 101 shows the Variable I/O Decode Ranges. They are set using Base Address Registers (BARs) or other configuration bits in the various PCI configuration spaces. The PNP software (PCI or ACPI) can use their configuration mechanisms to set and adjust these values.

**Warning:** The Variable I/O Ranges should not be set to conflict with the Fixed I/O Ranges. Unpredictable results if the configuration software allows conflicts to occur. The ICH8 does not perform any checks for conflicts.

Table 101. Variable I/O Decode Ranges

Range Name	Mappable	Size (Bytes)	Target
ACPI	Anywhere in 64 KB I/O Space	64	Power Management
IDE Bus Master (Mobile only)	Anywhere in 64 KB I/O Space	16	IDE Unit
Native IDE Command (Mobile only)	Anywhere in 64 KB I/O Space	8	IDE Unit
Native IDE Control (Mobile only)	Anywhere in 64 KB I/O Space	4	IDE Unit
USB UHCI Controller #1	Anywhere in 64 KB I/O Space	32	USB Unit 1
USB UHCI Controller #2	Anywhere in 64 KB I/O Space	32	USB Unit 2
USB UHCI Controller #3	Anywhere in 64 KB I/O Space	32	USB Unit 3
USB UHCI Controller #4	Anywhere in 64 KB I/O Space	32	USB Unit 4
USB UHCI Controller #5	Anywhere in 64 KB I/O Space	32	USB Unit 5
SMBus	Anywhere in 64 KB I/O Space	32	SMB Unit
TCO	96 Bytes above ACPI Base	32	TCO Unit
GPIO	Anywhere in 64 KB I/O Space	64	GPIO Unit
Parallel Port	3 Ranges in 64 KB I/O Space	8	LPC Peripheral
Serial Port 1	8 Ranges in 64 KB I/O Space	8	LPC Peripheral
Serial Port 2	8 Ranges in 64 KB I/O Space	8	LPC Peripheral
Floppy Disk Controller	2 Ranges in 64 KB I/O Space	8	LPC Peripheral
LAN	Anywhere in 64 KB I/O Space	32	LAN Unit
LPC Generic 1	Anywhere in 64 KB I/O Space	4 to 256	LPC Peripheral
LPC Generic 2	Anywhere in 64 KB I/O Space	4 to 256	LPC Peripheral
LPC Generic 3	Anywhere in 64 KB I/O Space	4 to 256	LPC Peripheral
LPC Generic 4	Anywhere in 64 KB I/O Space	4 to 256	LPC Peripheral
I/O Trapping Ranges	Anywhere in 64 KB I/O Space	1 to 256	Trap on Backbone

**NOTE:**

1. Decode range size determined by D31:F0:ADh:bits 5:4.



## 6.4 Memory Map

Table 102 shows (from the processor perspective) the memory ranges that the ICH8 decodes. Cycles that arrive from DMI that are not directed to any of the internal memory targets that decode directly from DMI will be driven out on PCI unless the Subtractive Decode Policy bit is set (D31:F0:Offset 42h, bit 0).

PCI cycles generated by external PCI masters will be positively decoded unless they fall in the PCI-to-PCI bridge memory forwarding ranges (those addresses are reserved for PCI peer-to-peer traffic). If the cycle is not in the internal LAN controller's range, it will be forwarded up to DMI. Software must not attempt locks to the ICH8's memory-mapped I/O ranges for EHCI and HPET. If attempted, the lock is not honored which means potential deadlock conditions may occur.

**Table 102. Memory Decode Ranges from Processor Perspective (Sheet 1 of 2)**

Memory Range	Target	Dependency/Comments
0000 0000h–000D FFFFh 0010 0000h–TOM (Top of Memory)	Main Memory	TOM registers in Host controller
000E 0000h–000E FFFFh	Firmware Hub	Bit 6 in Firmware Hub Decode Enable register is set
000F 0000h–000F FFFFh	Firmware Hub	Bit 7 in Firmware Hub Decode Enable register is set
FEC0 x000h–FEC0 x040h	IO(x) APIC inside ICH8	X is controlled via APIC Range Select (ASEL) field and APIC Enable (AEN) bit
FEC1 0000h–FEC1 7FFF	PCI Express* Port 1	PCI Express* Root Port 1 I/OxAPIC Enable (PAE) set
FEC1 8000h–FEC1 8FFFh	PCI Express* Port 2	PCI Express* Root Port 2 I/OxAPIC Enable (PAE) set
FEC2 0000h–FEC2 7FFFh	PCI Express* Port 3	PCI Express* Root Port 3 I/OxAPIC Enable (PAE) set
FEC2 8000h–FEC2 8FFFh	PCI Express* Port 4	PCI Express* Root Port 4 I/OxAPIC Enable (PAE) set
FEC3 0000h–FEC3 7FFFh	PCI Express* Port 5	PCI Express* Root Port 5 I/OxAPIC Enable (PAE) set
FEC3 8000h–FEC3 8FFFh	PCI Express* Port 6	PCI Express* Root Port 6 I/OxAPIC Enable (PAE) set
FED4 0000h–FED4 BFFFh	TPM on LPC	
FFC0 0000h–FFC7 FFFFh FF80 0000h–FF87 FFFFh	Firmware Hub (or PCI) <sup>2</sup>	Bit 8 in Firmware Hub Decode Enable register is set
FFC8 0000h–FFCF FFFFh FF88 0000h–FF8F FFFFh	Firmware Hub (or PCI) <sup>2</sup>	Bit 9 in Firmware Hub Decode Enable register is set
FFD0 0000h–FFD7 FFFFh FF90 0000h–FF97 FFFFh	Firmware Hub (or PCI) <sup>2</sup>	Bit 10 in Firmware Hub Decode Enable register is set
FFD8 0000h–FFDF FFFFh FF98 0000h–FF9F FFFFh	Firmware Hub (or PCI) <sup>2</sup>	Bit 11 in Firmware Hub Decode Enable register is set
FFE0 000h–FFE7 FFFFh FFA0 0000h–FFA7 FFFFh	Firmware Hub (or PCI) <sup>2</sup>	Bit 12 in Firmware Hub Decode Enable register is set



Table 102. Memory Decode Ranges from Processor Perspective (Sheet 2 of 2)

Memory Range	Target	Dependency/Comments
FFE8 0000h–FFEF FFFFh FFA8 0000h–FFAF FFFFh	Firmware Hub (or PCI) <sup>3</sup>	Bit 13 in Firmware Hub Decode Enable register is set
FFF0 0000h–FFF7 FFFFh FFB0 0000h–FFB7 FFFFh	Firmware Hub (or PCI) <sup>2</sup>	Bit 14 in Firmware Hub Decode Enable register is set
FFF8 0000h–FFFF FFFFh FFB8 0000h–FFBF FFFFh	Firmware Hub (or PCI) <sup>2</sup>	Always enabled. The top two, 64 KB blocks of this range can be swapped, as described in <a href="#">Section 7.4.1</a> .
FF70 0000h–FF7F FFFFh FF30 0000h–FF3F FFFFh	Firmware Hub (or PCI) <sup>2</sup>	Bit 3 in Firmware Hub Decode Enable register is set
FF60 0000h–FF6F FFFFh FF20 0000h–FF2F FFFFh	Firmware Hub (or PCI) <sup>2</sup>	Bit 2 in Firmware Hub Decode Enable register is set
FF50 0000h–FF5F FFFFh FF10 0000h–FF1F FFFFh	Firmware Hub (or PCI) <sup>2</sup>	Bit 1 in Firmware Hub Decode Enable register is set
FF40 0000h–FF4F FFFFh FF00 0000h–FF0F FFFFh	Firmware Hub (or PCI) <sup>2</sup>	Bit 0 in Firmware Hub Decode Enable register is set
128 KB anywhere in 4-GB range	Integrated LAN Controller	Enable via BAR in Device 25:Function 0 (Integrated LAN Controller)
1 KB anywhere in 4-GB range	USB EHCI Controller #1 <sup>1</sup>	Enable via standard PCI mechanism (Device 29, Function 7)
1 KB anywhere in 4-GB range	USB EHCI Controller #2 <sup>1</sup>	Enable via standard PCI mechanism (Device 26, Function 7)
512 B anywhere in 64-bit addressing space	Intel® High Definition Audio Host Controller	Enable via standard PCI mechanism (Device 27, Function 0)
FED0 X000h–FED0 X3FFh	High Precision Event Timers <sup>1</sup>	BIOS determines the “fixed” location which is one of four, 1-KB ranges where X (in the first column) is 0h, 1h, 2h, or 3h.
All other	PCI	None

**NOTES:**

1. Software must not attempt locks to memory mapped I/O ranges for USB EHCI or High Precision Event Timers. If attempted, the lock is not honored, which means potential deadlock conditions may occur.
2. PCI is the target when the Boot BIOS Destination selection bit is low (Chipset Config Registers:Offset 3401:bit 3). When PCI selected, the Firmware Hub Decode Enable bits have no effect.



## 6.4.1 Boot-Block Update Scheme

The ICH8 supports a “top-block swap” mode that has the ICH8 swap the top block in the Firmware Hub (the boot block) with another location. This allows for safe update of the Boot Block (even if a power failure occurs). When the “TOP\_SWAP” Enable bit is set, the ICH8 will invert A16 for cycles targeting Firmware Hub space. When this bit is 0, the ICH8 will not invert A16. This bit is automatically set to 0 by RTCRST#, but not by PLTRST#.

The scheme is based on the concept that the top block is reserved as the “boot” block, and the block immediately below the top block is reserved for doing boot-block updates.

The algorithm is:

1. Software copies the top block to the block immediately below the top
2. Software checks that the copied block is correct. This could be done by performing a checksum calculation.
3. Software sets the TOP\_SWAP bit. This will invert A16 for cycles going to the Firmware Hub. processor access to FFFF\_0000h through FFFF\_FFFFh will be directed to FFFE\_0000h through FFFE\_FFFFh in the Firmware Hub, and processor accesses to FFFE\_0000h through FFFE\_FFFF will be directed to FFFF\_0000h through FFFF\_FFFFh.
4. Software erases the top block
5. Software writes the new top block
6. Software checks the new top block
7. Software clears the TOP\_SWAP bit
8. Software sets the Top\_Swap Lock-Down bit

If a power failure occurs at any point after step 3, the system will be able to boot from the copy of the boot block that is stored in the block below the top. This is because the TOP\_SWAP bit is backed in the RTC well.

**Note:** The top-block swap mode may be forced by an external strapping option (See [Section 2.26.1](#)). When top-block swap mode is forced in this manner, the TOP\_SWAP bit cannot be cleared by software. A re-boot with the strap removed will be required to exit a forced top-block swap mode.

**Note:** Top-block swap mode only affects accesses to the Firmware Hub space, not feature space.

**Note:** The top-block swap mode has no effect on accesses below FFFE\_0000h.









## 7 Chipset Configuration Registers

This section describes all registers and base functionality that is related to chipset configuration and not a specific interface (such as LPC, PCI, or PCI Express\*). It contains the root complex register block, which describes the behavior of the upstream internal link.

This block is mapped into memory space, using register RCBA of the PCI-to-LPC bridge. Accesses in this space must be limited to 32-(DW) bit quantities. Burst accesses are not allowed.

### 7.1 Chipset Configuration Registers (Memory Space)

**Note:** Address locations that are not shown should be treated as Reserved (see Section 6.2 for details).

**Table 103. Chipset Configuration Register Memory Map (Memory Space) (Sheet 1 of 3)**

Offset	Mnemonic	Register Name	Default	Type
0000–0003h	VCH	Virtual Channel Capability Header	10010002h	RO
0004–0007h	VCAP1	Virtual Channel Capability #1	00000801h	RO
0008–000Bh	VCAP2	Virtual Channel Capability #2	00000001h	RO
000C–000Dh	PVC	Port VC Control	0000h	R/W, RO
000E–000Fh	PVS	Port VC Status	0000h	RO
0010–0013h	VOCAP	VC 0 Resource Capability	00000001h	RO
0014–0017h	VOCTL	VC 0 Resource Control	800000FFh	R/W, RO
001A–001Bh	VOSTS	VC 0 Resource Status	0000h	RO
001C–001Fh	V1CAP	VC 1 Resource Capability	30008010h	R/WO, RO
0020–0023h	V1CTL	VC 1 Resource Control	00000000h	R/W, RO
0026–0027h	V1STS	VC 1 Resource Status	0000h	RO
0030–006Fh	PAT	Port Arbitration Table		
0088–008Bh	CIR1	Chipset Initialization Register 1	00000000h	R/WO, RO
0100–0103h	RCTCL	Root Complex Topology Capability List	1A010005h	RO
0104–0107h	ESD	Element Self Description	00000602h	R/WO, RO
0110–0113h	ULD	Upstream Link Descriptor	00000001h	R/WO, RO
0118–011Fh	ULBA	Upstream Link Base Address	000000000000000000h	R/WO
0120–0123h	RP1D	Root Port 1 Descriptor	01xx0002h	R/WO, RO
0128–012Fh	RP1BA	Root Port 1 Base Address	000000000000E0000h	RO
0130–0133h	RP2D	Root Port 2 Descriptor	02xx0002h	R/WO, RO
0138–013Fh	RP2BA	Root Port 2 Base Address	000000000000E1000h	RO



**Table 103. Chipset Configuration Register Memory Map (Memory Space) (Sheet 2 of 3)**

Offset	Mnemonic	Register Name	Default	Type
0140–0143h	RP3D	Root Port 3 Descriptor	03xx0002h	R/WO, RO
0148–014Fh	RP3BA	Root Port 3 Base Address	0000000000E2000h	RO
0150–0153h	RP4D	Root Port 4 Descriptor	04xx0002h	R/WO, RO
0158–015Fh	RP4BA	Root Port 4 Base Address	0000000000E3000h	RO
0160–0163h	HDD	Intel® High Definition Audio Descriptor	15xx0002h	R/WO, RO
0168–016Fh	HDBA	Intel High Definition Audio Base Address	0000000000D8000h	RO
0170–0173h	RP5D	Root Port 5 Descriptor	05xx0002h	R/WO, RO
0178–017Fh	RP5A	Root Port 5 Base Address	0000000000E4000h	RO
0180–0183h	RP6D	Root Port 6 Descriptor	06xx0002h	R/WO, RO
0188–018Fh	RP6BA	Root Port 6 Base Address	0000000000E5000h	RO
01A0–01A3h	ILCL	Internal Link Capability List	00010006h	RO
01A4–01A7h	LCAP	Link Capabilities	00012441h	RO, R/WO
01A8–01A9h	LCTL	Link Control	0000h	R/W
01AA–01ABh	LSTS	Link Status	0041h	RO
01FC–01FDh	CIR3	Chipset Initialization Register 3	0000h	R/W, RO
0200–0201h	CIR4	Chipset Initialization Register 4	0000h	R/W, RO
0220–0223h	BCR	Backbone Configuration Register	00000000	R/W
0224–0227h	RPC	Root Port Configuration	0000000xh	R/W, RO
0234–0237h	DMIC	DMI Control Register	00000000h	R/W, RO
0238–023Bh	RPFN	Root Port Function Number for PCI Express Root Ports	00543210h	R/WO, RO
1D40–1D47h	CIR5	Chipset Initialization Register 5	0000000000000000h	R/W, R/WL
1E00–1E03h	TRSR	Trap Status Register	00000000h	R/WC, RO
1E10–1E17h	TRCR	Trapped Cycle Register	0000000000000000h	RO
1E18–1E1Fh	TWDR	Trapped Write Data Register	0000000000000000h	RO
1E80–1E87h	IOTR0	I/O Trap Register 0	0000000000000000h	R/W, RO
1E88–1E8Fh	IOTR1	I/O Trap Register 1	0000000000000000h	R/W, RO
1E90–1E97h	IOTR2	I/O Trap Register 2	0000000000000000h	R/W, RO
1E98–1E9Fh	IOTR3	I/O Trap Register 3	0000000000000000h	R/W, RO



Table 103. Chipset Configuration Register Memory Map (Memory Space) (Sheet 3 of 3)

Offset	Mnemonic	Register Name	Default	Type
2010–2013h	DMC	DMI Miscellaneous Control Register (Mobile Only)	Not Applicable	R/W
2024–2027h	CIR6	Chipset Initialization Register 6 (Mobile Only)	0B2030XXh	R/W, RO
2034–2037h	CIR7	Chipset Initialization Register 7	B2B477CCh	R/W
3000–3001h	TCTL	TCO Control	00h	R/W
3100–3103h	D31IP	Device 31 Interrupt Pin	03243210h	R/W, RO
3104–3107h	D30IP	Device 30 Interrupt Pin	00000000h	R/W, RO
3108–310Bh	D29IP	Device 29 Interrupt Pin	10004321h	R/W
310C–310Fh	D28IP	Device 28 Interrupt Pin	00004321h	R/W
3110–3113h	D27IP	Device 27 Interrupt Pin	00000001h	R/W
3114–3117h	D26IP	Device 26 Interrupt Pin	30000021h	R/W, RO
3118–3121h	D25IP	Device 25 Interrupt Pin	00000001h	R/W, RO
3140–3141h	D31IR	Device 31 Interrupt Route	3210h	R/W
3144–3145h	D29IR	Device 29 Interrupt Route	3210h	R/W
3146–3147h	D28IR	Device 28 Interrupt Route	3210h	R/W
3148–3149h	D27IR	Device 27 Interrupt Route	3210h	R/W
314C–314Dh	D26IR	Device 26 Interrupt Route	3210h	R/W
3150–3151h	D25IR	Device 25 Interrupt Route	3210h	R/W
31FF–31FFh	OIC	Other Interrupt Control	00h	R/W
3400–3403h	RC	RTC Configuration	00000000h	R/W, R/WLO
3404–3407h	HPTC	High Precision Timer Configuration	00000000h	R/W
3410–3413h	GCS	General Control and Status	0000000xh	R/W, R/WLO
3414–3414h	BUC	Backed Up Control	0000001xb (Mobile) 0000000xb (Desktop)	R/W
3418–341Bh	FD	Function Disable	See bit description	R/W, RO
341C–341Fh	CG	Clock Gating (Mobile Only)	00000000h	R/W, RO
3420h	FDSW	Function Disable SUS Well	00h	R/W, RO
3430h	CIR8	Chipset Initialization Register 8	00h	R/W, RO
350Ch–350Fh	CIR9	Chipset Initialization Register 9	00000000h	R/W, RO



### 7.1.1 VCH—Virtual Channel Capability Header Register

Offset Address: 0000–0003h                      Attribute: RO  
Default Value: 10010002h                      Size: 32-bit

Bit	Description
31:20	Next Capability Offset (NCO) — RO. Indicates the next item in the list.
19:16	Capability Version (CV) — RO. Indicates support as a version 1 capability structure.
15:0	Capability ID (CID) — RO. Indicates this is the Virtual Channel capability item.

### 7.1.2 VCAP1—Virtual Channel Capability #1 Register

Offset Address: 0004–0007h                      Attribute: RO  
Default Value: 00000000h                      Size: 32-bit

Bit	Description
31:12	Reserved
11:10	Port Arbitration Table Entry Size (PATS) — RO. Indicates the size of the port arbitration table is 4 bits (to allow up to 8 ports).
9:8	Reference Clock (RC) — RO. Fixed at 100 ns.
7	Reserved
6:4	Low Priority Extended VC Count (LPEVC) — RO. Indicates that there are no additional VCs of low priority with extended capabilities.
3	Reserved
2:0	Extended VC Count (EVC) — RO. Indicates that there is one additional VC (VC1) that exists with extended capabilities.

### 7.1.3 VCAP2—Virtual Channel Capability #2 Register

Offset Address: 0008–000Bh                      Attribute: RO  
Default Value: 00000001h                      Size: 32-bit

Bit	Description
31:24	VC Arbitration Table Offset (ATO) — RO. Indicates that no table is present for VC arbitration since it is fixed.
23:8	Reserved
7:0	VC Arbitration Capability (AC) — RO. Indicates that the VC arbitration is fixed in the root complex.



### 7.1.4 PVC—Port Virtual Channel Control Register

Offset Address: 000C–000Dh                      Attribute: R/W, RO  
 Default Value: 0000h                              Size: 16-bit

Bit	Description
15:04	Reserved
3:1	VC Arbitration Select (AS) — RO. Indicates which VC should be programmed in the VC arbitration table. The root complex takes no action on the setting of this field since there is no arbitration table.
0	Load VC Arbitration Table (LAT) — RO. Indicates that the table programmed should be loaded into the VC arbitration table. This bit is defined as read/write with always returning 0 on reads.

### 7.1.5 PVS—Port Virtual Channel Status Register

Offset Address: 000E–000Fh                      Attribute: RO  
 Default Value: 0000h                              Size: 16-bit

Bit	Description
15:01	Reserved
0	VC Arbitration Table Status (VAS) — RO. Indicates the coherency status of the VC Arbitration table when it is being updated. This field is always 0 in the root complex since there is no VC arbitration table.

### 7.1.6 VOCAP—Virtual Channel 0 Resource Capability Register

Offset Address: 0010–0013h                      Attribute: RO  
 Default Value: 00000001h                      Size: 32-bit

Bit	Description
31:24	Port Arbitration Table Offset (AT) — RO. This VC implements no port arbitration table since the arbitration is fixed.
23	Reserved
22:16	Maximum Time Slots (MTS) — RO. This VC implements fixed arbitration, and therefore this field is not used.
15	Reject Snoop Transactions (RTS) — RO. This VC must be able to take snoopable transactions.
14	Advanced Packet Switching (APS) — RO. This VC is capable of all transactions, not just advanced packet switching transactions.
13:8	Reserved
7:0	Port Arbitration Capability (PAC) — RO. Indicates that this VC uses fixed port arbitration.



### 7.1.7 VOCTL—Virtual Channel 0 Resource Control Register

Offset Address: 0014–0017h                      Attribute:                      R/W, RO  
Default Value: 800000FFh                      Size:                              32-bit

Bit	Description
31	Virtual Channel Enable (EN) — RO. Always set to 1. VCO is always enabled and cannot be disabled.
30:27	Reserved
26:24	Virtual Channel Identifier (ID) — RO. Indicates the ID to use for this virtual channel.
23:20	Reserved
19:17	<b>Port Arbitration Select (PAS)</b> — R/W. Indicates which port table is being programmed. The root complex takes no action on this setting since the arbitration is fixed and there is no arbitration table.
16	Load Port Arbitration Table (LAT) — RO. The root complex does not implement an arbitration table for this virtual channel.
15:8	Reserved
7:1	<b>Transaction Class / Virtual Channel Map (TVM)</b> — R/W. Indicates which transaction classes are mapped to this virtual channel. When a bit is set, this transaction class is mapped to the virtual channel.
0	Reserved

### 7.1.8 VOSTS—Virtual Channel 0 Resource Status Register

Offset Address: 001A–001Bh                      Attribute:                      RO  
Default Value: 0000h                              Size:                              16-bit

Bit	Description
15:02	Reserved
1	<b>VC Negotiation Pending (NP)</b> — RO. When set, indicates the virtual channel is still being negotiated with ingress ports.
0	Port Arbitration Tables Status (ATS) — RO. There is no port arbitration table for this VC, so this bit is reserved at 0.



### 7.1.9 V1CAP—Virtual Channel 1 Resource Capability Register

Offset Address: 001C–001Fh                      Attribute:                      R/WO, RO  
 Default Value: 30008010h                      Size:                              32-bit

Bit	Description
31:24	Port Arbitration Table Offset (AT) — RO. Indicates the location of the port arbitration table in the root complex. A value of 3h indicates the table is at offset 30h.
23	Reserved
22:16	<b>Maximum Time Slots (MTS)</b> — R/WO. This value is updated by platform BIOS based upon the determination of the number of time slots available in the platform.
15	Reject Snoop Transactions (RTS) — RO. All snoopable transactions on VC1 are rejected. This VC is for isochronous transfers only.
14	Advanced Packet Switching (APS) — RO. This VC is capable of all transactions, not just advanced packet switching transactions.
13:8	Reserved
7:0	Port Arbitration Capability (PAC) — RO. Indicates the port arbitration capability is time-based WRR of 128 phases.

### 7.1.10 V1CTL—Virtual Channel 1 Resource Control Register

Offset Address: 0020–0023h                      Attribute:                      R/W, RO  
 Default Value: 00000000h                      Size:                              32-bit

Bit	Description
31	<b>Virtual Channel Enable (EN)</b> — R/W. Enables the VC when set. Disables the VC when cleared.
30:27	Reserved
26:24	<b>Virtual Channel Identifier (ID)</b> — R/W. Indicates the ID to use for this virtual channel.
23:20	Reserved
19:17	<b>Port Arbitration Select (PAS)</b> — R/W. Indicates which port table is being programmed. The only permissible value of this field is 4h for the time-based WRR entries.
16	<b>Load Port Arbitration Table (LAT)</b> — RO/W. When set, the port arbitration table loaded based upon the PAS field in this register. This bit always returns 0 when read.
15:8	Reserved
7:1	<b>Transaction Class / Virtual Channel Map (TVM)</b> — R/W. Indicates which transaction classes are mapped to this virtual channel. When a bit is set, this transaction class is mapped to the virtual channel.
0	Reserved



### 7.1.11 V1STS—Virtual Channel 1 Resource Status Register

Offset Address: 0026–0027h                      Attribute: RO  
 Default Value: 0000h                              Size: 16-bit

Bit	Description
15:02	Reserved
1	<b>VC Negotiation Pending (NP)</b> — RO. When set, indicates the virtual channel is still being negotiated with ingress ports.
0	<b>Port Arbitration Tables Status (ATS)</b> — RO. Indicates the coherency status of the port arbitration table. This bit is set when LAT (offset 000Ch:bit 0) is written with value 1 and PAS (offset 0014h:bits19: 17) has value of 4h. This bit is cleared after the table has been updated.

### 7.1.12 PAT—Port Arbitration Table

Offset Address: 0030–006Fh                      Attribute:  
 Default Value:                                      Size: 64-Byte

This is a 64-byte register that contains the arbitration table to be loaded into the port arbitration table. Every 4-bits contains an entry for one of the downstream PCI-Express ports or a 0h to indicate idle. The ports are mapped as follows:

- Port 1: Value used is 1h.
- Port 2: Value used is 2h.
- Port 3: Value used is 3h
- Port 4: Value used is 4h
- Port 5: Value used is 5h
- Port 6: Value used is 6h
- Intel® High Definition Audio: Value used is Fh

This table is copied to an internal structure used during port arbitration when V1CTL.PAS is set to 04h, and V1CTL.LAT is set to 1.

### 7.1.13 CIR1—Chipset Initialization Register 1

Offset Address: 0088–008Bh                      Attribute: R/WO, RO  
 Default Value: 00000000h                      Size: 32-bit

Bit	Description
31:21	Reserved
20	<b>CIR1 Field 3</b> — R/WO. BIOS must set this bit.
19:16	Reserved
15	<b>CIR1 Field 2</b> — R/WO. BIOS must set this bit.
14:13	Reserved
12	<b>CIR1 Field 1</b> — R/WO. BIOS must set this bit.
11:0	Reserved





### 7.1.14 RCTCL—Root Complex Topology Capabilities List Register

Offset Address: 0100–0103h                      Attribute: RO  
 Default Value: 1A010005h                      Size: 32-bit

Bit	Description
31:20	Next Capability (NEXT) — RO. Indicates the next item in the list.
19:16	Capability Version (CV) — RO. Indicates the version of the capability structure.
15:0	Capability ID (CID) — RO. Indicates this is a PCI Express* link capability section of an RCRB.

### 7.1.15 ESD—Element Self Description Register

Offset Address: 0104–0107h                      Attribute: R/WO, RO  
 Default Value: 00000602h                      Size: 32-bit

Bit	Description
31:24	Port Number (PN) — RO. A value of 0 to indicate the egress port for the Intel® ICH.
23:16	<b>Component ID (CID)</b> — R/WO. This field indicates the component ID assigned to this element by software. This is written once by platform BIOS and is locked until a platform reset.
15:8	Number of Link Entries (NLE) — RO. This field indicates that one link entry (corresponding to DMI), 6 root port entries (for the downstream ports), and the Intel® High Definition Audio device are described by this RCRB.
7:4	Reserved
3:0	Element Type (ET) — RO. This field indicates that the element type is a root complex internal link.

### 7.1.16 ULD—Upstream Link Descriptor Register

Offset Address: 0110–0113h                      Attribute: R/WO, RO  
 Default Value: 00000001h                      Size: 32-bit

Bit	Description
31:24	<b>Target Port Number (PN)</b> — R/WO. This field is programmed by platform BIOS to match the port number of the (G)MCH RCRB that is attached to this RCRB.
23:16	<b>Target Component ID (TCID)</b> — R/WO. This field is programmed by platform BIOS to match the component ID of the (G)MCH RCRB that is attached to this RCRB.
15:2	Reserved
1	<b>Link Type (LT)</b> — RO. This field indicates that the link points to the (G)MCH RCRB.
0	<b>Link Valid (LV)</b> — RO. This field indicates that the link entry is valid.



### 7.1.17 ULBA—Upstream Link Base Address Register

Offset Address: 0118–011Fh      Attribute: R/WO  
 Default Value: 0000000000000000h      Size: 64-bit

Bit	Description
63:32	<b>Base Address Upper (BAU)</b> — R/WO. This field is programmed by platform BIOS to match the upper 32-bits of base address of the (G)MCH RCRB that is attached to this RCRB.
31:0	<b>Base Address Lower (BAL)</b> — R/WO. This field is programmed by platform BIOS to match the lower 32-bits of base address of the (G)MCH RCRB that is attached to this RCRB.

### 7.1.18 RP1D—Root Port 1 Descriptor Register

Offset Address: 0120–0123h      Attribute: R/WO, RO  
 Default Value: 01xx0002h      Size: 32-bit

Bit	Description
31:24	<b>Target Port Number (PN)</b> — RO. Indicates the target port number is 1h (root port #1).
23:16	<b>Target Component ID (TCID)</b> — R/WO. This field returns the value of the ESD.CID (offset 0104h, bits 23:16) field programmed by platform BIOS, since the root port is in the same component as the RCRB.
15:2	Reserved
1	<b>Link Type (LT)</b> — RO. Indicates that the link points to a root port.
0	<b>Link Valid (LV)</b> — RO. When FD.PE1D (offset 3418h, bit 16) is set, this link is not valid (returns 0). When FD.PE1D is cleared, this link is valid (returns 1).

### 7.1.19 RP1BA—Root Port 1 Base Address Register

Offset Address: 0128–012Fh      Attribute: RO  
 Default Value: 000000000000E0000h      Size: 64-bit

Bit	Description
63:32	Reserved
31:28	Reserved
27:20	<b>Bus Number (BN)</b> — RO. Indicates the root port is on bus #0.
19:15	<b>Device Number (DN)</b> — RO. Indicates the root port is on device #28.
14:12	<b>Function Number (FN)</b> — RO. Indicates the root port is on function #0.
11:0	Reserved



### 7.1.20 RP2D—Root Port 2 Descriptor Register

Offset Address: 0130–0133h      Attribute: R/WO, RO  
 Default Value: 02xx0002h      Size: 32-bit

Bit	Description
31:24	Target Port Number (PN) — RO. Indicates the target port number is 2h (root port #2).
23:16	<b>Target Component ID (TCID)</b> — R/WO. This field returns the value of the ESD.CID (offset 0104h, bits 23:16) field programmed by platform BIOS, since the root port is in the same component as the RCRB.
15:2	Reserved
1	Link Type (LT) — RO. Indicates that the link points to a root port.
0	<b>Link Valid (LV)</b> — RO. When RPC.PC (offset 0224h, bits 1:0) is '01', '10', or '11', or FD.PE2D (offset 3418h, bit 17) is set, the link for this root port is not valid (return 0). When RPC.PC is '00' and FD.PE2D is cleared, the link for this root port is valid (return 1).

### 7.1.21 RP2BA—Root Port 2 Base Address Register

Offset Address: 0138–013Fh      Attribute: RO  
 Default Value: 000000000000E1000h      Size: 64-bit

Bit	Description
63:32	Reserved
31:28	Reserved
27:20	Bus Number (BN) — RO. Indicates the root port is on bus #0.
19:15	Device Number (DN) — RO. Indicates the root port is on device #28.
14:12	Function Number (FN) — RO. Indicates the root port is on function #1.
11:0	Reserved

### 7.1.22 RP3D—Root Port 3 Descriptor Register

Offset Address: 0140–0143h      Attribute: R/WO, RO  
 Default Value: 03xx0002h      Size: 32-bit

Bit	Description
31:24	Target Port Number (PN) — RO. Indicates the target port number is 3h (root port #3).
23:16	<b>Target Component ID (TCID)</b> — R/WO. This field returns the value of the ESD.CID (offset 0104h, bits 23:16) field programmed by platform BIOS, since the root port is in the same component as the RCRB.
15:2	Reserved
1	Link Type (LT) — RO. Indicates that the link points to a root port.
0	<b>Link Valid (LV)</b> — RO. When RPC.PC (offset 0224h, bits 1:0) is '11', or FD.PE3D (offset 3418h, bit 18) is set, the link for this root port is not valid (return 0). When RPC.PC is '00', '01', or '10', and FD.PE3D is cleared, the link for this root port is valid (return 1).



### 7.1.23 RP3BA—Root Port 3 Base Address Register

Offset Address: 0148–014Fh      Attribute: RO  
 Default Value: 0000000000E2000h      Size: 64-bit

Bit	Description
63:32	Reserved
31:28	Reserved
27:20	Bus Number (BN) — RO. Indicates the root port is on bus #0.
19:15	Device Number (DN) — RO. Indicates the root port is on device #28.
14:12	Function Number (FN) — RO. Indicates the root port is on function #2.
11:0	Reserved

### 7.1.24 RP4D—Root Port 4 Descriptor Register

Offset Address: 0150–0153h      Attribute: R/WO, RO  
 Default Value: 04xx0002h      Size: 32-bit

Bit	Description
31:24	Target Port Number (PN) — RO. Indicates the target port number is 4h (root port #4).
23:16	<b>Target Component ID (TCID)</b> — R/WO. This field returns the value of the ESD.CID (offset 0104h, bits 23:16) field programmed by platform BIOS, since the root port is in the same component as the RCRB.
15:2	Reserved
1	Link Type (LT) — RO. Indicates that the link points to a root port.
0	<b>Link Valid (LV)</b> — RO. When RPC.PC (offset 0224h, bits 1:0) is '10' or '11', or FD.PE4D (offset 3418h, bit 19) is set, the link for this root port is not valid (return 0). When RPC.PC is '00' or '01' and FD.PE4D is cleared, the link for this root port is valid (return 1).

### 7.1.25 RP4BA—Root Port 4 Base Address Register

Offset Address: 0158–015Fh      Attribute: RO  
 Default Value: 0000000000E3000h      Size: 64-bit

Bit	Description
63:32	Reserved
31:28	Reserved
27:20	Bus Number (BN) — RO. Indicates the root port is on bus #0.
19:15	Device Number (DN) — RO. Indicates the root port is on device #28.
14:12	Function Number (FN) — RO. Indicates the root port is on function #3.
11:0	Reserved



### 7.1.26 HDD—Intel® High Definition Audio Descriptor Register

Offset Address: 0160–0163h                      Attribute:                      R/WO, RO  
 Default Value: 15xx0002h                      Size:                              32-bit

Bit	Description
31:24	Target Port Number (PN) — RO. Indicates the target port number is 15h (Intel® High Definition Audio).
23:16	<b>Target Component ID (TCID)</b> — R/WO. This field returns the value of the ESD.CID (offset 0104h, bits 23:16) field programmed by platform BIOS, since the root port is in the same component as the RCRB.
15:2	Reserved
1	Link Type (LT) — RO. Indicates that the link points to a root port.
0	<b>Link Valid (LV)</b> — RO. When FD.ZD (offset 3418h, bit 4) is set, the link to Intel High Definition Audio is not valid (return 0). When FD.ZD is cleared, the link to Intel High Definition Audio is valid (return 1).

### 7.1.27 HDBA—Intel® High Definition Audio Base Address Register

Offset Address: 0168–016Fh                      Attribute:                      RO  
 Default Value: 0000000000D8000h                      Size:                              64-bit

Bit	Description
63:32	Reserved
31:28	Reserved
27:20	Bus Number (BN) — RO. Indicates the root port is on bus #0.
19:15	Device Number (DN) — RO. Indicates the root port is on device #27.
14:12	Function Number (FN) — RO. Indicates the root port is on function #0.
11:0	Reserved

### 7.1.28 RP5D—Root Port 5 Descriptor Register

Offset Address: 0170–0173h                      Attribute:                      R/WO, RO  
 Default Value: 05xx0002h                      Size:                              32-bit

Bit	Description
31:24	Target Port Number (PN) — RO. Indicates the target port number is 5h (root port #5).
23:16	<b>Target Component ID (TCID)</b> — R/WO. This field returns the value of the ESD.CID (offset 0104h, bits 23:16) field programmed by platform BIOS, since the root port is in the same component as the RCRB.
15:2	Reserved
1	Link Type (LT) — RO. Indicates that the link points to a root port.
0	<b>Link Valid (LV)</b> — RO. When FD.PE5D (offset 3418h, bit 20) is set, the link for this root port is not valid (return 0). When FD.PE5D is cleared, the link for this root port is valid (return 1).



### 7.1.29 RP5BA—Root Port 5 Base Address Register

Offset Address: 0178–017Fh      Attribute: RO  
 Default Value: 00000000000E4000h      Size: 64-bit

Bit	Description
63:32	Reserved
31:28	Reserved
27:20	Bus Number (BN) — RO. Indicates the root port is on bus #0.
19:15	Device Number (DN) — RO. Indicates the root port is on device #28.
14:12	Function Number (FN) — RO. Indicates the root port is on function #4.
11:0	Reserved

### 7.1.30 RP6D—Root Port 6 Descriptor Register

Offset Address: 0180–0183h      Attribute: R/WO, RO  
 Default Value: 06xx0002h      Size: 32-bit

Bit	Description
31:24	Target Port Number (PN) — RO. Indicates the target port number is 6h (root port #6).
23:16	<b>Target Component ID (TCID)</b> — R/WO. This field returns the value of the ESD.CID (offset 0104h, bits 23:16) field programmed by platform BIOS, since the root port is in the same component as the RCRB.
15:2	Reserved
1	Link Type (LT) — RO. Indicates that the link points to a root port.
0	<b>Link Valid (LV)</b> — RO. When RPC.PC2 (offset 0224h, bits 1:0) is '01' or FD.PE6D (offset 3418h, bit 21) is set, the link for this root port is not valid (return 0). When RPC.PC is '00' and FD.PE6D is cleared, the link for this root port is valid (return 1).

### 7.1.31 RP6BA—Root Port 6 Base Address Register

Offset Address: 0188–018Fh      Attribute: RO  
 Default Value: 00000000000E5000h      Size: 64-bit

Bit	Description
63:32	Reserved
31:28	Reserved
27:20	Bus Number (BN) — RO. Indicates the root port is on bus 0.
19:15	Device Number (DN) — RO. Indicates the root port is on device 28.
14:12	Function Number (FN) — RO. Indicates the root port is on function 5.
11:0	Reserved



### 7.1.32 ILCL—Internal Link Capabilities List Register

Offset Address: 01A0–01A3h                      Attribute: RO  
 Default Value: 00010006h                      Size: 32-bit

Bit	Description
31:20	Next Capability Offset (NEXT) — RO. Indicates this is the last item in the list.
19:16	Capability Version (CV) — RO. Indicates the version of the capability structure.
15:0	Capability ID (CID) — RO. Indicates this is capability for DMI.

### 7.1.33 LCAP—Link Capabilities Register

Offset Address: 01A4–01A7h                      Attribute: RO/ R/WO  
 Default Value: 00012441h                      Size: 32-bit

Bit	Description
31:18	Reserved
17:15	L1 Exit Latency (EL1) — L1 not supported on DMI.
14:12	L0s Exit Latency (ELO) — R/WO. This field indicates that exit latency is 128 ns to less than 256 ns.
11:10 (Desktop Only)	Reserved
11:10 (Mobile Only)	Active State Link PM Support (APMS) — R/WO. Indicates that L0s is supported on DMI.
9:4	Maximum Link Width (MLW) — Indicates the maximum link width is 4 ports.
3:0	Maximum Link Speed (MLS) — Indicates the link speed is 2.5 Gb/s.



### 7.1.34 LCTL—Link Control Register

Offset Address: 01A8–01A9h      Attribute: R/W  
Default Value: 0000h      Size: 16-bit

Bit	Description
15:8	Reserved
7	<b>Extended Synch (ES)</b> — R/W. When set, forces extended transmission of FTS ordered sets when exiting L0s prior to entering L0.
6:2	Reserved
1:0 (Desktop Only)	Reserved
1:0 (Mobile Only)	<b>Active State Link PM Control (APMC)</b> — R/W. Indicates whether DMI should enter L0s. 00 = Disabled 01 = L0s entry enabled 10 = Reserved 11 = Reserved

### 7.1.35 LSTS—Link Status Register

Offset Address: 01AA–01ABh      Attribute: RO  
Default Value: 0041h      Size: 16-bit

Bit	Description
15:10	Reserved
9:4	<b>Negotiated Link Width (NLW)</b> — RO. Negotiated link width is x4 (000100b). ICH8M may also indicate x2 (000010b), depending on (G)MCH configuration.
3:0	Link Speed (LS) — RO. Link is 2.5 Gb/s.

### 7.1.36 CIR2 — Chipset Initialization Register 2

Offset Address: 01F4–01F7h      Attribute: R/W  
Default Value: 00000000h      Size: 32-bit

Bit	Description
31:0	<b>CIR2 Field 1</b> — R/W. BIOS shall program to 86000040h





### 7.1.37 CIR3 — Chipset Initialization Register 3

Offset Address: 01FC–01FDh                      Attribute: R/W, RO  
 Default Value: 0000h                              Size: 16-bit

Bit	Description
15:11	Reserved
10:8	<b>CIR3 Field 3</b> — R/W. BIOS must program this field to 110b.
7:4	Reserved
3	<b>CIR3 Field 2</b> — R/W. BIOS must set this bit.
2	Reserved
1:0	<b>CIR3 Field 1</b> — R/W. BIOS must program this field to 11b.

### 7.1.38 CIR4 — Chipset Initialization Register 4

Offset Address: 0200–0201h                      Attribute: R/W, RO  
 Default Value: 0000h                              Size: 16-bit

Bit	Description
15:14	Reserved
13:8	<b>CIR4 Field 2</b> — R/W. BIOS must program this field to 10 0000b
7:6	Reserved
5:0	<b>CIR4 Field 1</b> — R/W. BIOS must program this field to 00 1000b.

### 7.1.39 BCR — Backbone Configuration Register

Offset Address: 0220–0223h                      Attribute: R/W  
 Default Value: 00000000h                      Size: 32-bit

Bit	Description
31:7	Reserved
6	<b>BCR Field 2</b> — R/W. BIOS must set this bit.
5:3	Reserved
2:0	<b>BCR Field 1</b> — R/W. BIOS program this field to 101b



### 7.1.40 RPC—Root Port Configuration Register

Offset Address: 0224–0227h      Attribute: R/W, RO  
 Default Value: 0000000yh (y = 00xxb)      Size: 32-bit

Bit	Description
31:8	Reserved
7	<b>High Priority Port Enable (HPE)</b> — R/W. 0 = The high priority path is not enabled. 1 = The port selected by the HPP field in this register is enabled for high priority. It will be arbitrated above all other VCO (including integrated VCO) devices.
6:4	<b>High Priority Port (HPP)</b> — R/W. This controls which port is enabled for high priority when the HPE bit in this register is set. 111 = Reserved 110 = Reserved 101 = Port 6 100 = Port 5 011 = Port 4 010 = Port 3 001 = Port 2 000 = Port 1
3	Reserved
2	<b>Port Configuration2 (PC2)</b> — RO. This controls how the PCI bridges are organized in various modes of operation for Ports 5 and 6. 1 = Reserved 0 = 2 x1s, Port 5 (x1), Port 6 (x1) This bit is in the resume well and is only reset by RSMRST#.
1:0	<b>Port Configuration (PC)</b> — RO. This field controls how the PCI bridges are organized in various modes of operation for Ports 1–4. For the following mappings, if a port is not shown, it is considered a x1 port with no connection. These bits represent the strap values of HDA_SDOUT (bit 1) and HDA_SYNC (bit 0) when TP[3] is not pulled low at the rising edge of PWROK. 11 = 1 x4, Port 1 (x4) 10 = Reserved 01 = 1 x2 & 2 x1s, Port 1 (x2), Port 3 (x1), Port 4 (x1) 00 = 4 x1s, Port 1 (x1), Port 2 (x1), Port 3 (x1), Port 4 (x1) These bits live in the resume well and are only reset by RSMRST#.

### 7.1.41 DMIC—DMI Control Register

Offset Address: 0234–0237h      Attribute: R/W, RO  
 Default Value: 00000000h      Size: 32-bit

Bit	Description
31:2	Reserved
1:0	<b>DMI Clock Gate Enable (DMICGEN)</b> — R/W. BIOS must program this field to 00b (desktop) or 11b (mobile only)



### 7.1.42 RPFN—Root Port Function Number for PCI Express\* Root Ports

Offset Address: 0238–1E03h                      Attribute: R/WO, RO  
 Default Value: 00543210h                      Size: 32-bit

For the PCI Express root ports, the assignment of a function number to a root port is not fixed. BIOS may re-assign the function numbers on a port by port basis. This capability will allow BIOS to disable/hide any root port and have still have functions 0 thru N-1 where N is the total number of enabled root ports.

Port numbers will remain fixed to a physical root port.

The existing root port Function Disable registers operate on physical ports (not functions).

Port Configuration (1x4, 4x1, etc.) is not affected by the logical function number assignment and is associated with physical ports.

Bit	Description
31:23	Reserved
22:20	<b>Root Port 6 Function Number (RP6FN)</b> — R/WO. These bits set the function number for PCI Express Root Port 6. This root port function number must be a unique value from the other root port function numbers
19	Reserved
18:16	<b>Root Port 5 Function Number (RP5FN)</b> — R/WO. These bits set the function number for PCI Express Root Port 5. This root port function number must be a unique value from the other root port function numbers
15	Reserved
14:12	<b>Root Port 4 Function Number (RP4FN)</b> — R/WO. These bits set the function number for PCI Express Root Port 4. This root port function number must be a unique value from the other root port function numbers
11	Reserved
10:8	<b>Root Port 3 Function Number (RP3FN)</b> — R/WO. These bits set the function number for PCI Express Root Port 3. This root port function number must be a unique value from the other root port function numbers
7	Reserved
6:4	<b>Root Port 2 Function Number (RP2FN)</b> — R/WO. These bits set the function number for PCI Express Root Port 2. This root port function number must be a unique value from the other root port function numbers
3	Reserved
2:0	<b>Root Port 1 Function Number (RP1FN)</b> — R/WO. These bits set the function number for PCI Express Root Port 1. This root port function number must be a unique value from the other root port function numbers



### 7.1.43 CIR5—Chipset Initialization Register 5

Offset Address: 1D40h–1D47h      Attribute: R/W, R/WL  
 Default Value: 0000000000000000h      Size: 64-bit

Bit	Description
63:1	Reserved
0	<b>CIR5 Field 1</b> — R/W. BIOS must program this field to 1b

### 7.1.44 TRSR—Trap Status Register

Offset Address: 1E00–1E03h      Attribute: R/WC, RO  
 Default Value: 00000000h      Size: 32-bit

Bit	Description
31:4	Reserved
3:0	<b>Cycle Trap SMI# Status (CTSS)</b> — R/WC. These bits are set by hardware when the corresponding Cycle Trap register is enabled and a matching cycle is received (and trapped). These bits are OR'ed together to create a single status bit in the Power Management register space. Note that the SMI# and trapping must be enabled in order to set these bits. These bits are set before the completion is generated for the trapped cycle, thereby assuring that the processor can enter the SMI# handler when the instruction completes. Each status bit is cleared by writing a 1 to the corresponding bit location in this register.

### 7.1.45 TRCR—Trapped Cycle Register

Offset Address: 1E10–1E17h      Attribute: RO  
 Default Value: 0000000000000000h      Size: 64-bit

This register saves information about the I/O Cycle that was trapped and generated the SMI# for software to read.

Bit	Description
63:25	Reserved
24	<b>Read/Write# (RWI)</b> — RO. 0 = Trapped cycle was a write cycle. 1 = Trapped cycle was a read cycle.
23:20	Reserved
19:16	<b>Active-high Byte Enables (AHBE)</b> — RO. This is the dword-aligned byte enables associated with the trapped cycle. A 1 in any bit location indicates that the corresponding byte is enabled in the cycle.
15:2	<b>Trapped I/O Address (TIOA)</b> — RO. This is the dword-aligned address of the trapped cycle.
1:0	Reserved



### 7.1.46 TWDR—Trapped Write Data Register

Offset Address: 1E18–1E1Fh      Attribute: RO  
 Default Value: 0000000000000000h      Size: 64-bit

This register saves the data from I/O write cycles that are trapped for software to read.

Bit	Description
63:32	Reserved
31:0	<b>Trapped I/O Data (TIOD)</b> — RO. Dword of I/O write data. This field is undefined after trapping a read cycle.

### 7.1.47 IOTRn — I/O Trap Register (0–3)

Offset Address: 1E80–1E87h Register 0      Attribute: R/W, RO  
 1E88–1E8Fh Register 1  
 1E90–1E97h Register 2  
 1E98–1E9Fh Register 3  
 Default Value: 0000000000000000h      Size: 64-bit

These registers are used to specify the set of I/O cycles to be trapped and to enable this functionality.

Bit	Description
63:50	Reserved
49	<b>Read/Write Mask (RWM)</b> — R/W. 0 = The cycle must match the type specified in bit 48. 1 = Trapping logic will operate on both read and write cycles.
48	<b>Read/Write# (RWIO)</b> — R/W. 0 = Write 1 = Read <b>NOTE:</b> The value in this field does not matter if bit 49 is set.
47:40	Reserved
39:36	<b>Byte Enable Mask (BEM)</b> — R/W. A 1 in any bit position indicates that any value in the corresponding byte enable bit in a received cycle will be treated as a match. The corresponding bit in the Byte Enables field, below, is ignored.
35:32	<b>Byte Enables (TBE)</b> — R/W. Active-high dword-aligned byte enables.
31:24	Reserved
23:18	<b>Address[7:2] Mask (ADMA)</b> — R/W. A 1 in any bit position indicates that any value in the corresponding address bit in a received cycle will be treated as a match. The corresponding bit in the Address field, below, is ignored. The mask is only provided for the lower 6 bits of the dword address, allowing for traps on address ranges up to 256 bytes in size.
17:16	Reserved
15:2	<b>I/O Address[15:2] (IOAD)</b> — R/W. dword-aligned address
1	Reserved
0	<b>Trap and SMI # Enable (TRSE)</b> — R/W. 0 = Trapping and SMI# logic disabled. 1 = The trapping logic specified in this register is enabled.



### 7.1.48 DMC—DMI Miscellaneous Control Register (Mobile Only)

Offset Address: 2010–2013h                      Attribute: R/W  
Default Value: NA                                  Size: 32-bit

Bit	Description
31:2	Reserved
1	<b>DMI Misc. Control Field 1</b> — R/W. BIOS shall always program this field as per the BIOS Specification. 0 = Disable DMI Power Savings. 1 = Enable DMI Power Savings.
0	Reserved

### 7.1.49 CIR6—Chipset Initialization Register 6 (Mobile Only)

Offset Address: 2024–2027h                      Attribute: R/W, RO  
Default Value: 0B2030xxh                      Size: 32-bit

Bit	Description
31:24	Reserved
23:21	<b>CIR6 Field 2</b> — R/W. (Mobile Only) BIOS must program this field to 011b.
20:8	Reserved
7	<b>CIR6 Field 1</b> — R/W. BIOS must clear this bit.
6:0	Reserved

### 7.1.50 CIR7—Chipset Initialization Register 7

Offset Address: 2034–2037h                      Attribute: R/W  
Default Value: B2B477CCh                      Size: 32-bit

Bit	Description
31:20	Reserved
19:16	<b>CIR7 Field 1</b> — R/W. BIOS must program this field to 0101b.
15:0	Reserved



### 7.1.51 TCTL—TCO Configuration Register

Offset Address: 3000–3000h      Attribute: R/W  
 Default Value: 00h                Size: 8-bit

Bit	Description
7	<b>TCO IRQ Enable (IE)</b> — R/W. 0 = TCO IRQ is disabled. 1 = TCO IRQ is enabled, as selected by the TCO_IRQ_SEL field.
6:3	Reserved
2:0	<b>TCO IRQ Select (IS)</b> — R/W. Specifies on which IRQ the TCO will internally appear. If not using the APIC, the TCO interrupt must be routed to IRQ9-11, and that interrupt is not sharable with the SERIRQ stream, but is shareable with other PCI interrupts. If using the APIC, the TCO interrupt can also be mapped to IRQ20-23, and can be shared with other interrupt. 000 = IRQ 9 001 = IRQ 10 010 = IRQ 11 011 = Reserved 100 = IRQ 20 (only if APIC enabled) 101 = IRQ 21 (only if APIC enabled) 110 = IRQ 22 (only if APIC enabled) 111 = IRQ 23 (only if APIC enabled)  When setting the these bits, the IE bit should be cleared to prevent glitching. When the interrupt is mapped to APIC interrupts 9, 10 or 11, the APIC should be programmed for active-high reception. When the interrupt is mapped to APIC interrupts 20 through 23, the APIC should be programmed for active-low reception.



### 7.1.52 D31IP—Device 31 Interrupt Pin Register

Offset Address: 3100–3103h                      Attribute: R/W, RO  
 Default Value: 03243210h                      Size: 32-bit

Bit	Description
31:16	Reserved
27:24	<b>Thermal Throttle Pin (TTIP)</b> — R/W. This field indicates which pin the Thermal Throttle controller drives as its interrupt. 0h = No interrupt 1h = INTA# 2h = INTB# (Default) 3h = INTC# 4h = INTD# 5h–Fh = Reserved
23:20	<b>SATA Pin 2 (SIP2)</b> — R/W. This field indicates which pin the SATA controller 2 drives as its interrupt. 0h = No interrupt. 1h = INTA# 2h = INTB# (Default) 3h = INTC# 4h = INTD# 5h–Fh = Reserved
19:16	Reserved
15:12	<b>SM Bus Pin (SMIP)</b> — R/W. This field indicates which pin the SMBus controller drives as its interrupt. 0h = No interrupt 1h = INTA# 2h = INTB# (Default) 3h = INTC# 4h = INTD# 5h–Fh = Reserved
11:8	<b>SATA Pin (SIP)</b> — R/W. This field indicates which pin the SATA controller drives as its interrupt. 0h = No interrupt 1h = INTA# 2h = INTB# (Default) 3h = INTC# 4h = INTD# 5h–Fh = Reserved
7:4	<b>PATA Pin (SMIP)</b> — R/W. This field indicates which pin the PATA controller drives as its interrupt. 0h = No interrupt 1h = INTA# (Default) 2h = INTB# 3h = INTC# 4h = INTD# 5h–Fh = Reserved
3:0	LPC Bridge Pin (PIP) — RO. Currently, the LPC bridge does not generate an interrupt, so this field is read-only and 0.





### 7.1.53 D30IP—Device 30 Interrupt Pin Register

Offset Address: 3104–3107h                      Attribute: R/W, RO  
 Default Value: 00000000h                      Size: 32-bit

Bit	Description
31:4	Reserved
3:0	PCI Bridge Pin (LIP) — RO. Currently, the PCI bridge does not generate an interrupt, so this field is read-only and 0.

### 7.1.54 D29IP—Device 29 Interrupt Pin Register

Offset Address: 3108–310Bh                      Attribute: R/W  
 Default Value: 10004321h                      Size: 32-bit

Bit	Description
31:28	<b>EHCI Pin (EIP)</b> — R/W. This field indicates which pin the EHCI controller drives as its interrupt. 0h = No interrupt 1h = INTA# (Default) 2h = INTB# 3h = INTC# 4h = INTD# 5h–7h = Reserved
27:12	Reserved
11:8	<b>UHCI #2 Pin (U2P)</b> — R/W. This field indicates which pin the UHCI controller #2 (ports 4 and 5) drives as its interrupt. 0h = No interrupt 1h = INTA# 2h = INTB# 3h = INTC# (Default) 4h = INTD# 5h–7h = Reserved
7:4	<b>UHCI #1 Pin (U1P)</b> — R/W. This field indicates which pin the UHCI controller #1 (ports 2 and 3) drives as its interrupt. 0h = No interrupt 1h = INTA# 2h = INTB# (Default) 3h = INTC# 4h = INTD# 5h–7h = Reserved
3:0	<b>UHCI #0 Pin (U0P)</b> — R/W. This field indicates which pin the UHCI controller #0 (ports 0 and 1) drives as its interrupt. 0h = No interrupt 1h = INTA# (Default) 2h = INTB# 3h = INTC# 4h = INTD# 5h–7h = Reserved



### 7.1.55 D28IP—Device 28 Interrupt Pin Register

Offset Address: 310C–310Fh  
Default Value: 00214321h

Attribute: R/W  
Size: 32-bit

Bit	Description
31:16	Reserved
23:20	<b>PCI Express* #6 Pin (P6IP)</b> — R/W. This field indicates which pin the PCI Express* port #6 drives as its interrupt. 0h = No interrupt 1h = INTA# 2h = INTB# (Default) 3h = INTC# 4h = INTD# 5h–7h = Reserved
19:16	<b>PCI Express #5 Pin (P5IP)</b> — R/W. This field indicates which pin the PCI Express port #5 drives as its interrupt. 0h = No interrupt 1h = INTA# (Default) 2h = INTB# 3h = INTC# 4h = INTD# 5h–7h = Reserved
15:12	<b>PCI Express #4 Pin (P4IP)</b> — R/W. This field indicates which pin the PCI Express* port #4 drives as its interrupt. 0h = No interrupt 1h = INTA# 2h = INTB# 3h = INTC# 4h = INTD# (Default) 5h–7h = Reserved
11:8	<b>PCI Express #3 Pin (P3IP)</b> — R/W. This field indicates which pin the PCI Express port #3 drives as its interrupt. 0h = No interrupt 1h = INTA# 2h = INTB# 3h = INTC# (Default) 4h = INTD# 5h–7h = Reserved
7:4	<b>PCI Express #2 Pin (P2IP)</b> — R/W. This field indicates which pin the PCI Express port #2 drives as its interrupt. 0h = No interrupt 1h = INTA# 2h = INTB# (Default) 3h = INTC# 4h = INTD# 5h–7h = Reserved
3:0	<b>PCI Express #1 Pin (P1IP)</b> — R/W. This field indicates which pin the PCI Express port #1 drives as its interrupt. 0h = No interrupt 1h = INTA# (Default) 2h = INTB# 3h = INTC# 4h = INTD# 5h–7h = Reserved



### 7.1.56 D27IP—Device 27 Interrupt Pin Register

Offset Address: 3110–3113h                      Attribute: R/W  
 Default Value: 0000001h                      Size: 32-bit

Bit	Description
31:4	Reserved
3:0	<b>Intel® High Definition Audio Pin (ZIP)</b> — R/W. This field indicates which pin the Intel High Definition Audio controller drives as its interrupt. 0h = No interrupt 1h = INTA# (Default) 2h = INTB# 3h = INTC# 4h = INTD# 5h–Fh = Reserved

### 7.1.57 D26IP—Device 26 Interrupt Pin Register

Offset Address: 3114–3117h                      Attribute: R/W, RO  
 Default Value: 30000021h                      Size: 32-bit

Bit	Description
31:28	<b>EHCI #2 Pin (E2IP)</b> : This field indicates which pin the EHCI controller #2 drives as its interrupt: 0h = No Interrupt 1h = INTA# 2h = INTB# 3h = INTC# (Default) 4h = INTD# 5h–Fh = Reserved
27:8	Reserved
7:4	<b>UHCI #5 Pin (U5P)</b> : This field applies to UHCI controller #5 (ports 8 & 9) 0h = No Interrupt 1h = INTA# 2h = INTB# (Default) 3h = INTC# 4h = INTD# 5h–Fh = Reserved
3:0	<b>UHCI #4 Pin (U4P)</b> : This field applies to UHCI controller #4 (ports 6 and 7) 0h = No Interrupt 1h = INTA# (Default) 2h = INTB# 3h = INTC# 4h = INTD# 5h–Fh = Reserved



### 7.1.58 D25IP—Device 25 Interrupt Pin Register

Offset Address: 3118–3121h                      Attribute: RO, R/W  
 Default Value: 00000001h                      Size: 32-bit

Bit	Description
31:4	Reserved
3:0	<b>IGBE LAN Pin (LIP):</b> This field indicates which pin the internal GbE LAN controller drives as its interrupt 0h = No Interrupt 1h = INTA# (Default) 2h = INTB# 3h = INTC# 4h = INTD# 5h–Fh = Reserved

### 7.1.59 D31IR—Device 31 Interrupt Route Register

Offset Address: 3140–3141h                      Attribute: R/W  
 Default Value: 3210h                              Size: 16-bit

Bit	Description
15	Reserved
14:12	<b>Interrupt D Pin Route (IDR)</b> — R/W. This field indicates which physical pin on the Intel® ICH8 is connected to the INTD# pin reported for device 31 functions. 0h = PIRQA# 1h = PIRQB# 2h = PIRQC# 3h = PIRQD# (Default) 4h = PIRQE# 5h = PIRQF# 6h = PIRQG# 7h = PIRQH#
11	Reserved
10:8	<b>Interrupt C Pin Route (ICR)</b> — R/W. This field indicates which physical pin on the ICH8 is connected to the INTC# pin reported for device 31 functions. 0h = PIRQA# 1h = PIRQB# 2h = PIRQC# (Default) 3h = PIRQD# 4h = PIRQE# 5h = PIRQF# 6h = PIRQG# 7h = PIRQH#
7:4	Reserved
3	<b>NetDetect Enable (NDE)</b> — R/W. This register is in the RTC well instead of the SUS well to maintain state if the SUS well power is removed in S4. 0 = Disabled 1 = GPIO14 input signal is multiplexed onto the South MLink MLCLK pin as a NetDetect Request signal to the wireless LAN component.



Bit	Description
2:0	<b>Interrupt A Pin Route (IAR)</b> — R/W. This field indicates which physical pin on the ICH8 is connected to the INTA# pin reported for device 31 functions. 0h = PIRQA# (Default) 1h = PIRQB# 2h = PIRQC# 3h = PIRQD# 4h = PIRQE# 5h = PIRQF# 6h = PIRQG# 7h = PIRQH#

### 7.1.60 D30IR—Device 30 Interrupt Route Register

Offset Address: 3142–3143h                      Attribute: RO  
 Default Value: 0000h                              Size: 16-bit

Bit	Description
15:0	Reserved. No interrupts generated from Device 30

### 7.1.61 D29IR—Device 29 Interrupt Route Register

Offset Address: 3144–3145h                      Attribute: R/W  
 Default Value: 3210h                              Size: 16-bit

Bit	Description
15	Reserved
14:12	<b>Interrupt D Pin Route (IDR)</b> — R/W. This field indicates which physical pin on the Intel® ICH8 is connected to the INTD# pin reported for device 29 functions. 0h = PIRQA# 1h = PIRQB# 2h = PIRQC# 3h = PIRQD# (Default) 4h = PIRQE# 5h = PIRQF# 6h = PIRQG# 7h = PIRQH#
11	Reserved
10:8	<b>Interrupt C Pin Route (ICR)</b> — R/W. This field indicates which physical pin on the ICH8 is connected to the INTC# pin reported for device 29 functions. 0h = PIRQA# 1h = PIRQB# 2h = PIRQC# (Default) 3h = PIRQD# 4h = PIRQE# 5h = PIRQF# 6h = PIRQG# 7h = PIRQH#



Bit	Description
7	Reserved
6:4	<b>Interrupt B Pin Route (IBR)</b> — R/W. This field indicates which physical pin on the ICH8 is connected to the INTB# pin reported for device 29 functions. 0h = PIRQA# 1h = PIRQB# (Default) 2h = PIRQC# 3h = PIRQD# 4h = PIRQE# 5h = PIRQF# 6h = PIRQG# 7h = PIRQH#
3	Reserved
2:0	<b>Interrupt A Pin Route (IAR)</b> — R/W. This field indicates which physical pin on the ICH8 is connected to the INTA# pin reported for device 29 functions. 0h = PIRQA# (Default) 1h = PIRQB# 2h = PIRQC# 3h = PIRQD# 4h = PIRQE# 5h = PIRQF# 6h = PIRQG# 7h = PIRQH#



## 7.1.62 D28IR—Device 28 Interrupt Route Register

Offset Address: 3146–3147h  
 Default Value: 3210h

Attribute: R/W  
 Size: 16-bit

Bit	Description
15	Reserved
14:12	<b>Interrupt D Pin Route (IDR)</b> — R/W. This field indicates which physical pin on the Intel® ICH8 is connected to the INTD# pin reported for device 28 functions. 0h = PIRQA# 1h = PIRQB# 2h = PIRQC# 3h = PIRQD# (Default) 4h = PIRQE# 5h = PIRQF# 6h = PIRQG# 7h = PIRQH#
11	Reserved
10:8	<b>Interrupt C Pin Route (ICR)</b> — R/W. This field indicates which physical pin on the ICH8 is connected to the INTC# pin reported for device 28 functions. 0h = PIRQA# 1h = PIRQB# 2h = PIRQC# (Default) 3h = PIRQD# 4h = PIRQE# 5h = PIRQF# 6h = PIRQG# 7h = PIRQH#
7	Reserved
6:4	<b>Interrupt B Pin Route (IBR)</b> — R/W. This field indicates which physical pin on the ICH8 is connected to the INTB# pin reported for device 28 functions. 0h = PIRQA# 1h = PIRQB# (Default) 2h = PIRQC# 3h = PIRQD# 4h = PIRQE# 5h = PIRQF# 6h = PIRQG# 7h = PIRQH#
3	Reserved
2:0	<b>Interrupt A Pin Route (IAR)</b> — R/W. This field indicates which physical pin on the ICH8 is connected to the INTA# pin reported for device 28 functions. 0h = PIRQA# (Default) 1h = PIRQB# 2h = PIRQC# 3h = PIRQD# 4h = PIRQE# 5h = PIRQF# 6h = PIRQG# 7h = PIRQH#



### 7.1.63 D27IR—Device 27 Interrupt Route Register

Offset Address: 3148–3149h  
Default Value: 3210h

Attribute: R/W  
Size: 16-bit

Bit	Description
15	Reserved
14:12	<b>Interrupt D Pin Route (IDR)</b> — R/W. This field indicates which physical pin on the Intel® ICH8 is connected to the INTD# pin reported for device 27 functions. 0h = PIRQA# 1h = PIRQB# 2h = PIRQC# 3h = PIRQD# (Default) 4h = PIRQE# 5h = PIRQF# 6h = PIRQG# 7h = PIRQH#
11	Reserved
10:8	<b>Interrupt C Pin Route (ICR)</b> — R/W. This field indicates which physical pin on the ICH8 is connected to the INTC# pin reported for device 27 functions. 0h = PIRQA# 1h = PIRQB# 2h = PIRQC# (Default) 3h = PIRQD# 4h = PIRQE# 5h = PIRQF# 6h = PIRQG# 7h = PIRQH#
7	Reserved
6:4	<b>Interrupt B Pin Route (IBR)</b> — R/W. This field indicates which physical pin on the ICH8 is connected to the INTB# pin reported for device 27 functions. 0h = PIRQA# 1h = PIRQB# (Default) 2h = PIRQC# 3h = PIRQD# 4h = PIRQE# 5h = PIRQF# 6h = PIRQG# 7h = PIRQH#
3	Reserved
2:0	<b>Interrupt A Pin Route (IAR)</b> — R/W. This field indicates which physical pin on the ICH8 is connected to the INTA# pin reported for device 27 functions. 0h = PIRQA# (Default) 1h = PIRQB# 2h = PIRQC# 3h = PIRQD# 4h = PIRQE# 5h = PIRQF# 6h = PIRQG# 7h = PIRQH#





## 7.1.64 D26IR—Device 26 Interrupt Route Register

Offset Address: 314C–314Dh  
 Default Value: 3210h

Attribute: R/W  
 Size: 16-bit

Bit	Description
15	Reserved
14:12	<p><b>Interrupt D Pin Route (IDR):</b> This field indicates which physical pin on the ICH8 is connected to the INTD# pin reported for device 26 functions:</p> <p>0h = PIRQA#            1h = PIRQB#            2h = PIRQC#            3h = PIRQD# (Default)            4h = PIRQE#            5h = PIRQF#            6h = PIRQG#            7h = PIRQH#</p>
11	Reserved
10:8	<p><b>Interrupt C Pin Route (ICR) — R/W.</b> This field indicates which physical pin on the ICH8 is connected to the INTC# pin reported for device 26 functions.</p> <p>0h = PIRQA#            1h = PIRQB#            2h = PIRQC# (Default)            3h = PIRQD#            4h = PIRQE#            5h = PIRQF#            6h = PIRQG#            7h = PIRQH#</p>
7	Reserved
6:4	<p><b>Interrupt B Pin Route (IBR) — R/W.</b> This field indicates which physical pin on the ICH8 is connected to the INTB# pin reported for device 26 functions.</p> <p>0h = PIRQA#            1h = PIRQB# (Default)            2h = PIRQC#            3h = PIRQD#            4h = PIRQE#            5h = PIRQF#            6h = PIRQG#            7h = PIRQH#</p>
3	Reserved
2:0	<p><b>Interrupt A Pin Route (IAR) — R/W.</b> This field indicates which physical pin on the ICH8 is connected to the INTA# pin reported for device 26 functions.</p> <p>0h = PIRQA# (Default)            1h = PIRQB#            2h = PIRQC#            3h = PIRQD#            4h = PIRQE#            5h = PIRQF#            6h = PIRQG#            7h = PIRQH#</p>



### 7.1.65 D25IR—Device 25 Interrupt Route Register

Offset Address: 3150–3151h  
Default Value: 3210h

Attribute: R/W  
Size: 16-bit

Bit	Description
15	Reserved
14:12	<b>Interrupt D Pin Route (IDR):</b> This field indicates which physical pin on the ICH8 is connected to the INTD# pin reported for device 25 functions: 0h = PIRQA# 1h = PIRQB# 2h = PIRQC# 3h = PIRQD# (Default) 4h = PIRQE# 5h = PIRQF# 6h = PIRQG# 7h = PIRQH#
11	Reserved
10:8	<b>Interrupt C Pin Route (ICR) — R/W.</b> This field indicates which physical pin on the ICH8 is connected to the INTC# pin reported for device 25 functions. 0h = PIRQA# 1h = PIRQB# 2h = PIRQC# (Default) 3h = PIRQD# 4h = PIRQE# 5h = PIRQF# 6h = PIRQG# 7h = PIRQH#
7	Reserved
6:4	<b>Interrupt B Pin Route (IBR) — R/W.</b> This field indicates which physical pin on the ICH8 is connected to the INTB# pin reported for device 25 functions. 0h = PIRQA# 1h = PIRQB# (Default) 2h = PIRQC# 3h = PIRQD# 4h = PIRQE# 5h = PIRQF# 6h = PIRQG# 7h = PIRQH#
3	Reserved
2:0	<b>Interrupt A Pin Route (IAR) — R/W.</b> This field indicates which physical pin on the ICH8 is connected to the INTA# pin reported for device 25 functions. 0h = PIRQA# (Default) 1h = PIRQB# 2h = PIRQC# 3h = PIRQD# 4h = PIRQE# 5h = PIRQF# 6h = PIRQG# 7h = PIRQH#



### 7.1.66 OIC—Other Interrupt Control Register

Offset Address: 31FF–31FFh                      Attribute: R/W  
 Default Value: 00h                                Size: 8-bit

Bit	Description
7:4	<b>APIC Range Select (ASEL):</b> These bits define address bits 15:12 for the IOxAPIC range. The default value of 0h enables compatibility with prior ICH8 products as an initial value. This value must not be changed unless the IOxAPIC Enable bit is cleared.
3:2	Reserved
1	<b>Coprocessor Error Enable (CEN)</b> — R/W. 0 = FERR# will not generate IRQ13 nor IGNNE#. 1 = If FERR# is low, the Intel® ICH8 generates IRQ13 internally and holds it until an I/O port F0h write. It will also drive IGNNE# active.
0	<b>APIC Enable (AEN)</b> — R/W. 0 = The internal IOxAPIC is disabled. 1 = Enables the internal IOxAPIC and its address decode.  <b>NOTE:</b> Software should read this register after modifying APIC Enable bit prior to access to the IOxAPIC address range.

### 7.1.67 RC—RTC Configuration Register

Offset Address: 3400–3403h                      Attribute: R/W, R/WLO  
 Default Value: 00000000h                      Size: 32-bit

Bit	Description
31:5	Reserved
4	<b>Upper 128 Byte Lock (UL)</b> — R/WLO. 0 = Bytes not locked. 1 = Bytes 38h-3Fh in the upper 128-byte bank of RTC RAM are locked and cannot be accessed. Writes will be dropped and reads will not return any assured data. Bit reset on system reset.
3	<b>Lower 128 Byte Lock (LL)</b> — R/WLO. 0 = Bytes not locked. 1 = Bytes 38h-3Fh in the lower 128-byte bank of RTC RAM are locked and cannot be accessed. Writes will be dropped and reads will not return any assured data. Bit reset on system reset.
2	<b>Upper 128 Byte Enable (UE)</b> — R/W. 0 = Bytes locked. 1 = The upper 128-byte bank of RTC RAM can be accessed.
1:0	Reserved



### 7.1.68 HPTC—High Precision Timer Configuration Register

Offset Address: 3404–3407h                      Attribute: R/W  
Default Value: 00000000h                      Size: 32-bit

Bit	Description
31:8	Reserved
7	<b>Address Enable (AE)</b> — R/W. 0 = Address disabled. 1 = The Intel® ICH8 will decode the High Precision Timer memory address range selected by bits 1:0 below.
6:2	Reserved
1:0	<b>Address Select (AS)</b> — R/W. This 2-bit field selects 1 of 4 possible memory address ranges for the High Precision Timer functionality. The encodings are: 00 = FED0_0000h - FED0_03FFh 01 = FED0_1000h - FED0_13FFh 10 = FED0_2000h - FED0_23FFh 11 = FED0_3000h - FED0_33FFh



## 7.1.69 GCS—General Control and Status Register

Offset Address: 3410–3413h Attribute: R/W, R/WLO  
 Default Value: 00000yy0h (yy = xx0000x0b) Size: 32-bit

Bit	Description								
31:12	Reserved								
11:10	<p><b>Boot BIOS Straps (BBS):</b> This field determines the destination of accesses to the BIOS memory range. The default values for these bits represent the strap values of GNT0# (bit 11) and SPI_CS1# (bit 10) at the rising edge of PWROK.</p> <table border="1"> <thead> <tr> <th>Bits 11:10</th> <th>Description</th> </tr> </thead> <tbody> <tr> <td>0xb</td> <td>SPI</td> </tr> <tr> <td>10b</td> <td>PCI</td> </tr> <tr> <td>11b</td> <td>LPC</td> </tr> </tbody> </table> <p>When PCI is selected, the top 16MB of memory below 4GB (FF00_0000h to FFFF_FFFFh) is accepted by the primary side of the PCI P2P bridge and forwarded to the PCI bus. This allows systems with corrupted or unprogrammed flash to boot from a PCI device. The PCI-to-PCI bridge Memory Space Enable bit does not need to be set (nor any other bits) in order for these cycles to go to PCI. Note that BIOS decode range bits and the other BIOS protection bits have no effect when PCI is selected.</p> <p>When SPI or LPC is selected, the range that is decoded is further qualified by other configuration bits described in the respective sections.</p> <p>The value in this field can be overwritten by software as long as the BIOS Interface Lock-Down (bit 0) is not set.</p> <p><b>NOTE:</b> Boot BIOS Destination Select to LPC/PCI by functional strap or via Boot BIOS Destination Bit will not affect SPI accesses initiated by ME or Integrated GbE LAN.</p>	Bits 11:10	Description	0xb	SPI	10b	PCI	11b	LPC
Bits 11:10	Description								
0xb	SPI								
10b	PCI								
11b	LPC								
9	<p><b>Server Error Reporting Mode (SERM) — R/W.</b></p> <p>0 = The Intel® ICH8 is the final target of all errors. The (G)MCH sends a messages to the ICH8 for the purpose of generating NMI.</p> <p>1 = The (G)MCH is the final target of all errors from PCI Express* and DMI. In this mode, if the ICH8 detects a fatal, non-fatal, or correctable error on DMI or its downstream ports, it sends a message to the (G)MCH. If the ICH8 receives an ERR_* message from the downstream port, it sends that message to the (G)MCH.</p>								
8	Reserved								
7 (Mobile only)	<p><b>Mobile IDE Configuration Lock Down (MICLD) — R/WLO.</b></p> <p>0 = Disabled.</p> <p>1 = BUC.PRS (offset 3414h, bit 1) is locked and cannot be written until a system reset occurs. This prevents rogue software from changing the default state of the PATA pins during boot after BIOS configures them. This bit is write once, and is cleared by system reset and when returning from the S3/S4/S5 states.</p>								
7:6 (Desktop only)	Reserved								
6 (Mobile only)	<p><b>FERR# MUX Enable (FME) — R/W.</b> This bit enables FERR# to be a processor break event indication. See <a href="#">Chapter 5.13.5</a> for a functional description.</p> <p>0 = Disabled.</p> <p>1 = The ICH8 examines FERR# during a C2, C3, or C4 state as a break event.</p>								



Bit	Description
5	<p><b>No Reboot (NR)</b> — R/W. This bit is set when the “No Reboot” strap (SPKR pin on ICH8) is sampled high on PWROK. This bit may be set or cleared by software if the strap is sampled low but may not override the strap when it indicates “No Reboot”.</p> <p>0 = System will reboot upon the second timeout of the TCO timer.            1 = The TCO timer will count down and generate the SMI# on the first timeout, but will not reboot on the second timeout.</p>
4	<p><b>Alternate Access Mode Enable (AME)</b> — R/W.</p> <p>0 = Disabled.            1 = Alternate access read only registers can be written, and write only registers can be read. Before entering a low power state, several registers from powered down parts may need to be saved. In the majority of cases, this is not an issue, as registers have read and write paths. However, several of the ISA compatible registers are either read only or write only. To get data out of write-only registers, and to restore data into read-only registers, the ICH8 implements an alternate access mode. For a list of these registers see <a href="#">Section 5.13.10</a>.</p>
3	<p><b>Shutdown Policy Select (SPS)</b> — R/W. When cleared (default), the ICH8 will drive INIT# in response to the shutdown Vendor Defined Message (VDM). When set to 1, ICH8 will treat the shutdown VDM similar to receiving a CF9h I/O write with data value 06h, and will drive PLTRST# active.</p>
2	<p><b>Reserved Page Route (RPR)</b> — R/W. Determines where to send the reserved page registers. These addresses are sent to PCI or LPC for the purpose of generating POST codes. The I/O addresses modified by this field are: 80h, 84h, 85h, 86h, 88h, 8Ch, 8Dh, and 8Eh.</p> <p>0 = Writes will be forwarded to LPC, shadowed within the ICH, and reads will be returned from the internal shadow            1 = Writes will be forwarded to PCI, shadowed within the ICH, and reads will be returned from the internal shadow.</p> <p>Note, if some writes are done to LPC/PCI to these I/O ranges, and then this bit is flipped, such that writes will now go to the other interface, the reads will not return what was last written. Shadowing is performed on each interface.</p> <p>The aliases for these registers, at 90h, 94h, 95h, 96h, 98h, 9Ch, 9Dh, and 9Eh, are always decoded to LPC.</p>
1	Reserved
0	<p><b>BIOS Interface Lock-Down (BILD)</b> — R/WLO.</p> <p>0 = Disabled.            1 = Prevents BUC.TS (offset 3414, bit 0) and GCS.BBS (offset 3410h, bits 11:10) from being changed. This bit can only be written from 0 to 1 once.</p>



### 7.1.70 BUC—Backed Up Control Register

Offset Address: 3414–3414h      Attribute: R/W  
 Default Value: 0000000xb (Desktop)      Size: 8-bit  
                   0000001xb (Mobile)

All bits in this register are in the RTC well and only cleared by RTCRST#.

Bit	Description
7:3	Reserved
2	<b>CPU BIST Enable (CBE)</b> — R/W. This bit is in the resume well and is reset by RSMRST#, but not PLTRST# nor CF9h writes. 0 = Disabled. 1 = The INIT# signals will be driven active when CPURST# is active. INIT# and INIT3_3V# will go inactive with the same timings as the other processor interface signals (hold time after CPURST# inactive).
1 (Mobile only)	<b>PATA Reset State (PRS)</b> — R/W. 0 = Disabled. 1 = The reset state of the PATA pins will be driven/tri-state.
1 (Desktop only)	Reserved
0	<b>Top Swap (TS)</b> — R/W. 0 = Intel® ICH8 will not invert A16. 1 = ICH8 will invert A16 for cycles going to the BIOS space (but not the feature space) in the FWH. If ICH8 is strapped for Top-Swap (GNT3# is low at rising edge of PWROK), then this bit cannot be cleared by software. The strap jumper should be removed and the system rebooted.

### 7.1.71 FD—Function Disable Register

Offset Address: 3418–341Bh      Attribute: R/W, RO  
 Default Value: See bit description      Size: 32-bit

The UHCI functions must be disabled from highest function number to lowest within each PCI device (Device 29 or Device 26). For example, if only two UHCIs are wanted on Device 29, software must disable UHCI #3 (UD3 bit set). When disabling UHCIs, the EHCI Structural Parameters Registers must be updated with coherent information in “Number of Companion Controllers” and “N\_Ports” fields.

When disabling a function, only the configuration space is disabled. Software must ensure that all functionality within a controller that is not desired (such as memory spaces, I/O spaces, and DMA engines) is disabled prior to disabling the function.

When a function is disabled, software must not attempt to re-enable it. A disabled function can only be re-enabled by a platform reset.



Bit	Description
31:26	Reserved
25	<b>Serial ATA Disable 2 (SAD2)</b> — R/W. Default is 0. 0 = The SATA controller #2 (D31:F5) is enabled. 1 = The SATA controller #2 (D31:F5) is disabled.
24	<b>Thermal Throttle Disable (TTD)</b> — R/W. Default is 0. 0 = Thermal Throttle is enabled. 1 = Thermal Throttle is disabled.
23:22	Reserved
21	<b>PCI Express* 6 Disable (PE6D)</b> — R/W. Default is 0. When disabled, the link for this port is put into the “link down” state. 0 = PCI Express* port #6 is enabled. 1 = PCI Express port #6 is disabled.
20	<b>PCI Express 5 Disable (PE5D)</b> — R/W. Default is 0. When disabled, the link for this port is put into the link down state. 0 = PCI Express port #5 is enabled. 1 = PCI Express port #5 is disabled.
19	<b>PCI Express 4 Disable (PE4D)</b> — R/W. Default is 0. When disabled, the link for this port is put into the “link down” state. 0 = PCI Express* port #4 is enabled. 1 = PCI Express port #4 is disabled.
18	<b>PCI Express 3 Disable (PE3D)</b> — R/W. Default is 0. When disabled, the link for this port is put into the link down state. 0 = PCI Express port #3 is enabled. 1 = PCI Express port #3 is disabled.
17	<b>PCI Express 2 Disable (PE2D)</b> — R/W. Default is 0. When disabled, the link for this port is put into the link down state. 0 = PCI Express port #2 is enabled. 1 = PCI Express port #2 is disabled.
16	<b>PCI Express 1 Disable (PE1D)</b> — R/W. Default is 0. When disabled, the link for this port is put into the link down state. 0 = PCI Express port #1 is enabled. 1 = PCI Express port #1 is disabled.
15	<b>EHCI #1 Disable (EHCI1D)</b> — R/W. Default is 0. 0 = The EHCI #1 is enabled. 1 = The EHCI #1 is disabled.
14	<b>LPC Bridge Disable (LBD)</b> — R/W. Default is 0. 0 = The LPC bridge is enabled. 1 = The LPC bridge is disabled. Unlike the other disables in this register, the following additional spaces will no longer be decoded by the LPC bridge: <ul style="list-style-type: none"> <li>• Memory cycles below 16 MB (1000000h)</li> <li>• I/O cycles below 64 KB (10000h)</li> <li>• The Internal I/OxAPIC at FEC0_0000 to FECF_FFFF</li> </ul> Memory cycles in the LPC BIOS range below 4 GB will still be decoded when this bit is set, but the aliases at the top of 1 MB (the E and F segment) no longer will be decoded.





Bit	Description
13	<p><b>EHCI #2 Disable (EHCI2D)</b> — R/W. Default is 0.            0 = The EHCI #2 is enabled.            1 = The EHCI #2 is disabled.</p> <p><b>NOTE:</b> When this bit is set, the UHCI #5 function is not available and the UHCI #4 must be disabled by setting bit 11 in this register.</p>
12	<p><b>USB1 #5 Disable (U5D)</b> — R/W. Default is 0            0 = The UHCI #5 is enabled.            1 = The UHCI #5 is disabled.</p> <p><b>NOTE:</b> When the EHCI #2 Device Disable (EHCI2D) is set, this bit is a don't care</p>
11	<p><b>UHCI #4 Disable (U4D)</b> — R/W. Default is 0.            0 = The 4th UHCI (ports 6 and 7) is enabled.            1 = The 4th UHCI (ports 6 and 7) is disabled.</p> <p><b>NOTE:</b> UHCI #4 must be disabled when EHCI #2 is disabled with bit 13 in this register.</p>
10	<p><b>UHCI #3 Disable (U3D)</b> — R/W. Default is 0.            0 = The 3rd UHCI (ports 4 and 5) is enabled.            1 = The 3rd UHCI (ports 4 and 5) is disabled.</p>
9	<p><b>UHCI #2 Disable (U2D)</b> — R/W. Default is 0.            0 = The 2nd UHCI (ports 2 and 3) is enabled.            1 = The 2nd UHCI (ports 2 and 3) is disabled.</p>
8	<p><b>UHCI #1 Disable (U1D)</b> — R/W. Default is 0.            0 = The 1st UHCI (ports 0 and 1) is enabled.            1 = The 1st UHCI (ports 0 and 1) is disabled.</p>
7:5	Reserved
4	<p><b>Intel® High Definition Audio Disable (ZD)</b> — R/W. Default is 0.            0 = The Intel High Definition Audio controller is enabled.            1 = The Intel High Definition Audio controller is disabled and its PCI configuration space is not accessible.</p>
3	<p><b>SM Bus Disable (SD)</b> — R/W. Default is 0.            0 = The SM Bus controller is enabled.            1 = The SM Bus controller is disabled. In ICH5 and previous, this also disabled the I/O space. In ICH8, it only disables the configuration space.</p>
2	<p><b>Serial ATA Disable 1 (SAD1)</b> — R/W. Default is 0.            0 = The SATA controller #1 (D31:F2) is enabled.            1 = The SATA controller #1 (D31:F2) is disabled.</p>
1	Reserved
0	BIOS must set this bit to 0b



## 7.1.72 CG—Clock Gating (Mobile Only)

Offset Address: 341C–341Fh  
 Default Value: 00000000h

Attribute: R/W, RO  
 Size: 32-bit

Bit	Description
31	<b>Legacy (LPC) Dynamic Clock Gate Enable</b> — R/W. 0 = Legacy Dynamic Clock Gating is Disabled 1 = Legacy Dynamic Clock Gating is Enabled
30	<b>PATA Dynamic Clock Gate Enable</b> — R/W. 0 = PATA Dynamic Clock Gating is Disabled 1 = PATA Dynamic Clock Gating is Enabled
29:28	<b>USB UHCI Dynamic Clock Gate Enable</b> — R/W. 0 = USB UHCI Dynamic Clock Gating is Disabled 1 = USB UHCI Dynamic Clock Gating is Enabled 0 = Reserved 1 = Reserved
27	Reserved
26	<b>SATA Port 2 Dynamic Clock Gate Enable</b> — R/W. 0 = SATA Port 2 Dynamic Clock Gating is Disabled 1 = SATA Port 2 Dynamic Clock Gating is Enabled
25	<b>SATA Port 1 Dynamic Clock Gate Enable</b> — R/W. 0 = SATA Port 1 Dynamic Clock Gating is Disabled 1 = SATA Port 1 Dynamic Clock Gating is Enabled
24	<b>SATA Port 0 Dynamic Clock Gate Enable</b> — R/W. 0 = SATA Port 0 Dynamic Clock Gating is Disabled 1 = SATA Port 0 Dynamic Clock Gating is Enabled
23	<b>LAN Static Clock Gating Enable (LANSCGE)</b> — R/W. 0 = LAN Static clock gating is disabled 1 = LAN Static clock gating is enabled when the LAN Disable bit is set in the Function Disable SUS Well register.
22	<b>High Definition Audio Dynamic Clock Gate Enable</b> — R/W. 0 = High Definition Audio Dynamic Clock Gating is Disabled 1 = High Definition Audio Dynamic Clock Gating is Enabled
21	<b>High Definition Audio Static Clock Gate Enable</b> — R/W. 0 = High Definition Audio Static Clock Gating is Disabled 1 = High Definition Audio Static Clock Gating is Enabled
20	<b>USB EHCI Static Clock Gate Enable</b> — R/W. 0 = USB EHCI Static Clock Gating is Disabled 1 = USB EHCI Static Clock Gating is Enabled
19	<b>USB EHCI Dynamic Clock Gate Enable</b> — R/W. 0 = USB EHCI Dynamic Clock Gating is Disabled 1 = USB EHCI Dynamic Clock Gating is Enabled
18:17	Reserved
16	<b>PCI Dynamic Gate Enable</b> — R/W. 0 = PCI Dynamic Gating is Disabled 1 = PCI Dynamic Gating is Enabled



Bit	Description
15	<b>IDE C3 HV IO Biasing Disable (IC3HVBD)</b> — R/W. 0 = IDE HV IO Biasing is always on 1 = IDE HV IO Biasing is disabled on selected pins when in C3.
14:5	Reserved
4	<b>PCI Express* RX Clock Gating Enable (PRXCGEN)</b> — R/W. 0 = AFE Rx clock gating is disabled 1 = AFE Rx clock gating is enabled whenever all PCIe ports Rx are in squelch
3	<b>DMI and PCI Express* RX Dynamic Clock Gate Enable</b> — R/W. 0 = DMI and PCI Express root port RX Dynamic Clock Gating is Disabled 1 = DMI and PCI Express root port RX Dynamic Clock Gating is Enabled
2	<b>PCI Express TX Dynamic Clock Gate Enable</b> — R/W. 0 = PCI Express root port TX Dynamic Clock Gating is Disabled 1 = PCI Express root port TX Dynamic Clock Gating is Enabled
1	<b>DMI TX Dynamic Clock Gate Enable</b> — R/W. 0 = DMI TX Dynamic Clock Gating is Disabled 1 = DMI TX Dynamic Clock Gating is Enabled
0	<b>PCI Express Root Port Static Clock Gate Enable</b> — R/W. 0 = PCI Express root port Static Clock Gating is Disabled 1 = PCI Express root port Static Clock Gating is Enabled

### 7.1.73 FDSW—Function Disable SUS Well

Offset Address: 3420h  
Default Value: 0000h

Attribute: R/W, RO  
Size: 8-bit

Bit	Description
7	<b>Function Disable SUS Well Lockdown (FDSWL)</b> — R/WL 0 = FDSW registers are not locked down 1 = FDSW registers are locked down <b>NOTE:</b> This bit must be set when Intel® Active Management Technology is enabled (ICH8DO and ICH8M-E Only).
6:1	Reserved
0	<b>LAN Disable</b> — R/WL 0 = LAN is enabled 1 = LAN is Disabled. If the Function Disable SUS Well Lockdown bit is set, this register is locked.



### 7.1.74 CIR8—Chipset Initialization Register 8

Offset Address: 3430h Attribute: R/W, RO  
Default Value: 00h Size: 8-bit

Bit	Description
7:2	Reserved
1:0	<b>CIR8 Field 1</b> — R/W. BIOS must program this field to 11b.

### 7.1.75 CIR9—Chipset Initialization Register 9

Offset Address: 350Ch–350Fh Attribute: R/W, RO  
Default Value: 00000000h Size: 32-bit

Bit	Description
31:28	Reserved
27:26	<b>CIR9 Field 1</b> — R/W. BIOS must program this field to 10b.
25:0	Reserved

§ §



## 8 Gigabit LAN Configuration Registers

### 8.1 Gigabit LAN Configuration Registers (Gigabit LAN — D25:F0)

**Note:** Register address locations that are not shown in Table 143 and should be treated as Reserved.

**Table 104. Gigabit LAN Configuration Registers Address Map (Gigabit LAN —D25:F0) (Sheet 1 of 2)**

Offset	Mnemonic	Register Name	Function 0 Default	Type
00h–01h	VID	Vendor Identification	8086h	RO
02h–03h	DID	Device Identification	See register description	RO
04h–05h	PCICMD	PCI Command	0000h	R/W, RO
06h–07h	PCISTS	PCI Status	0010h	R/WC, RO
08h	RID	Revision Identification	See register description	RO
09h–0Bh	CC	Class Code	020000	RO
0Ch	CLS	Cache Line Size	00h	R/W
0Dh	PLT	Primary Latency Timer	00h	RO
0Eh	HEADTYP	Header Type	00h	RO
10h–13h	MBARA	Memory Base Address A	00000000h	R/W, RO
14h–17h	MBARB	Memory Base Address B	00000000h	R/W, RO
18h–1Bh	MBARC	Memory Base Address C	00000000h	R/W, RO
2Ch–2Dh	SID	Subsystem ID	See register description.	RO
2Eh–2Fh	SVID	Subsystem Vendor ID	See register description	RO
30h–33h	ERBA	Expansion ROM Base Address	See register description	RO
34h	CAPP	Capabilities List Pointer	C8h	RO
3Ch–3Dh	INTR	Interrupt Information	See register description.	R/W, RO
3Eh	MLMG	Maximum Latency/Minimum Grant	00h	RO
C8h–C9h	CLIST1	Capabilities List 1	D001h	RO
CAh–CBh	PMC	PCI Power Management Capability	See register description	RO
CCh–CDh	PMCS	PCI Power Management Control and Status	See register description	R/WC, R/W, RO



**Table 104. Gigabit LAN Configuration Registers Address Map (Gigabit LAN —D25:F0) (Sheet 2 of 2)**

Offset	Mnemonic	Register Name	Function 0 Default	Type
CFh	DR	Data Register	See register description	RO
D0h–D1h	CLIST2	Capabilities List 2	0005h	RO
D2h–D3h	MCTL	Message Control	0080h	R/W, RO
D4h–D7h	MADDL	Message Address Low	See register description	R/W
D8h–DBh	MADDH	Message Address High	See register description	R/W
DCh–DDh	MDAT	Message Data	See register description	R/W

### 8.1.1 VID—Vendor Identification Register (Gigabit LAN—D25:F0)

Address Offset: 00h–01h                      Attribute: RO  
 Default Value: 8086h                         Size: 16 bits

Bit	Description
15:0	Vendor ID — RO. This is a 16-bit value assigned to Intel. The field may be auto-loaded from the NVM at address 0Eh during init time depending on the "Load Vendor/Device ID" bit field in NVM word 0Ah with a default value of 8086h.

### 8.1.2 DID—Device Identification Register (Gigabit LAN—D25:F0)

Address Offset: 02h–03h                      Attribute: RO  
 Default Value: See bit description         Size: 16 bits

Bit	Description
15:0	Device ID — RO. This is a 16-bit value assigned to the Intel® ICH8 Gigabit LAN controller. The field may be auto-loaded from the NVM word 0Dh during initialization time depending on the "Load Vendor/Device ID" bit field in NVM word 0Ah.



### 8.1.3 PCI\_CMD—PCI Command Register (Gigabit LAN—D25:F0)

Address Offset: 04h–05h  
Default Value: 0000h

Attribute: R/W, RO  
Size: 16 bits

Bit	Description
15:11	Reserved
10	<p><b>Interrupt Disable</b> — R/W. This disables pin-based INTx# interrupts on enabled Hot-Plug and power management events. This bit has no effect on MSI operation.</p> <p>0 = Internal INTx# messages are generated if there is an interrupt for Hot-Plug or power management and MSI is not enabled.</p> <p>1 = Internal INTx# messages will not be generated.</p> <p>This bit does not affect interrupt forwarding from devices connected to the root port. Assert_INTx and Deassert_INTx messages will still be forwarded to the internal interrupt controllers if this bit is set.</p>
9	<b>Fast Back to Back Enable (FBE)</b> — RO. Hardwired to '0'.
8	<p><b>SERR# Enable (SEE)</b> — R/W.</p> <p>0 = Disable</p> <p>1 = Enables the Gb LAN controller to generate an SERR# message when PSTS.SSE is set.</p>
7	<b>Wait Cycle Control (WCC)</b> — RO. Hardwired to '0'.
6	<p><b>Parity Error Response (PER)</b> — R/W.</p> <p>0 = Disable.</p> <p>1 = Indicates that the device is capable of reporting parity errors as a master on the backbone.</p>
5	<b>Palette Snoop Enable (PSE)</b> — RO. Hardwired to '0'.
4	<b>Postable Memory Write Enable (PMWE)</b> — RO. Hardwired to '0'.
3	<b>Special Cycle Enable (SCE)</b> — RO. Hardwired to '0'.
2	<p><b>Bus Master Enable (BME)</b> — R/W.</p> <p>0 = Disable. All cycles from the device are master aborted</p> <p>1 = Enable. Allows the root port to forward cycles onto the backbone from a Gigabit LAN* device.</p>
1	<p><b>Memory Space Enable (MSE)</b> — R/W.</p> <p>0 = Disable. Memory cycles within the range specified by the memory base and limit registers are master aborted on the backbone.</p> <p>1 = Enable. Allows memory cycles within the range specified by the memory base and limit registers can be forwarded to the Gigabit LAN device.</p>
0	<p><b>I/O Space Enable (IOSE)</b> — R/W. This bit controls access to the I/O space registers.</p> <p>0 = Disable. I/O cycles within the range specified by the I/O base and limit registers are master aborted on the backbone.</p> <p>1 = Enable. Allows I/O cycles within the range specified by the I/O base and limit registers can be forwarded to the Gigabit LAN device.</p>



### 8.1.4 PCISTS—PCI Status Register (Gigabit LAN—D25:F0)

Address Offset: 06h–07h  
Default Value: 0010h

Attribute: R/WC, RO  
Size: 16 bits

Bit	Description
15	<b>Detected Parity Error (DPE)</b> — R/WC. 0 = No parity error detected. 1 = Set when the Gb LAN controller receives a command or data from the backbone with a parity error. This is set even if PCIMD.PER (D25:F0, bit 6) is not set.
14	<b>Signaled System Error (SSE)</b> — R/WC. 0 = No system error signaled. 1 = Set when the Gb LAN controller signals a system error to the internal SERR# logic.
13	<b>Received Master Abort (RMA)</b> — R/WC. 0 = Root port has not received a completion with unsupported request status from the backbone. 1 = Set when the Gb LAN controller receives a completion with unsupported request status from the backbone.
12	<b>Received Target Abort (RTA)</b> — R/WC. 0 = Root port has not received a completion with completer abort from the backbone. 1 = Set when the Gb LAN controller receives a completion with completer abort from the backbone.
11	<b>Signaled Target Abort (STA)</b> — R/WC. 0 = No target abort received. 1 = Set whenever the Gb LAN controller forwards a target abort received from the downstream device onto the backbone.
10:9	<b>DEVSEL# Timing Status (DEV_STS)</b> — RO. Hardwired to '0'.
8	<b>Master Data Parity Error Detected (DPED)</b> — R/WC. 0 = No data parity error received. 1 = Set when the Gb LAN Controller receives a completion with a data parity error on the backbone and PCIMD.PER (D25:F0, bit 6) is set.
7	Fast Back to Back Capable (FB2BC) — RO. Hardwired to '0'.
6	Reserved
5	66 MHz Capable — RO. Hardwired to '0'.
4	Capabilities List — RO. Hardwired to '1'. Indicates the presence of a capabilities list.
3	Interrupt Status — RO. Indicates status of Hot-Plug and power management interrupts on the root port that result in INTx# message generation. 0 = Interrupt is deasserted. 1 = Interrupt is asserted.  This bit is not set if MSI is enabled. If MSI is not enabled, this bit is set regardless of the state of PCICMD.Interrupt Disable bit (D25:F0:04h:bit 10).
2:0	Reserved





### 8.1.5 RID—Revision Identification Register (Gigabit LAN—D25:F0)

Offset Address: 08h                      Attribute: RO  
 Default Value: See bit description      Size: 8 bits

Bit	Description
7:0	Revision ID — RO. Refer to the <i>Intel® I/O Controller Hub 8 (ICH8) Family Specification Update</i> for the value of the Revision ID Register.

### 8.1.6 CC—Class Code Register (Gigabit LAN—D25:F0)

Address Offset: 09h–0Bh                      Attribute: RO  
 Default Value: 020000h                      Size: 24 bits

Bit	Description
23:0	Class Code— RO. This field indicates the device as an Ethernet Adapter. 020000h = Ethernet Adapter.

### 8.1.7 CLS—Cache Line Size Register (Gigabit LAN—D25:F0)

Address Offset: 0Ch                      Attribute: R/W  
 Default Value: 00h                      Size: 8 bits

Bit	Description
7:0	Cache Line Size — R/W. This field is implemented by PCI devices as a readwrite field for legacy compatibility purposes but has no impact on any device functionality.

### 8.1.8 PLT—Primary Latency Timer Register (Gigabit LAN—D25:F0)

Address Offset: 0Dh                      Attribute: RO  
 Default Value: 00h                      Size: 8 bits

Bit	Description
7:0	Latency Timer (LT) — RO. Hardwired to 0.

### 8.1.9 HT—Header Type Register (Gigabit LAN—D25:F0)

Address Offset: 0Eh                      Attribute: RO  
 Default Value: 00h                      Size: 8 bits

Bit	Description
7:0	Header Type (HT) — RO. 00h = Indicates this is a single function device.



### 8.1.10 MBARA—Memory Base Address Register A (Gigabit LAN—D25:F0)

Address Offset: 10h–13h                      Attribute: R/W, RO  
Default Value: 00000000h                      Size: 32 bits

The internal CSR registers and memories are accessed as direct memory mapped offsets from the base address register. SW may only access whole DWord at a time.

Bit	Description
31:15	<b>Base Address (BA) — R/W.</b> Software programs this field with the base address of this region.
14:4	<b>Memory Size (MSIZE) — R/W.</b> Memory size is 32 KB.
3	Prefetchable Memory (PM) — RO. The Gb LAN controller does not implement prefetchable memory.
2:1	Memory Type (MT) — RO. Set to 00b indicating a 32 bit BAR.
0	Memory / IO Space (MIOS) — RO. Set to '0' indicating a Memory Space BAR.

### 8.1.11 MBARB—Memory Base Address Register B (Gigabit LAN—D25:F0)

Address Offset: 14h–17h                      Attribute: R/W, RO  
Default Value: 00000001h                      Size: 32 bits

The internal registers that are used to access the LAN Space in the External FLASH device. Accessed to these registers are direct memory mapped offsets from the base address register. SW may only access a DWord at a time.

Bit	Description
31:12	<b>Base Address (BA) — R/W.</b> Software programs this field with the base address of this region.
11:4	<b>Memory Size (MSIZE) — R/W.</b> Memory size is 4K Bytes.
3	Prefetchable Memory (PM) — RO. The Gb LAN controller does not implement prefetchable memory.
2:1	Memory Type (MT) — RO. Set to 00b indicating a 32 bit BAR.
0	Memory / IO Space (MIOS) — RO. Set to '0' indicating a Memory Space BAR.



### 8.1.12 MBARC—Memory Base Address Register C (Gigabit LAN—D25:F0)

Address Offset: 18h–1Bh                      Attribute: R/W, RO  
 Default Value: 00000000h                  Size: 32 bits

Internal registers, and memories, can be accessed using I/O operations. There are two 4B registers in the IO mapping window: Addr Reg and Data Reg. SW may only access a Dword at a time.

Bit	Description
31:5	<b>Base Address (BA) — R/W.</b> Software programs this field with the base address of this region.
4:1	<b>I/O Size (IOSIZE) — RO.</b> I/O space size is 32 Bytes.
0	<b>Memory / IO Space (MIOS) — RO.</b> Set to '1' indicating an IO Space BAR.

### 8.1.13 SID—Subsystem ID Register (Gigabit LAN—D25:F0)

Address Offset: 2Ch–2Dh                      Attribute: RO  
 Default Value: See bit description              Size: 16 bits

Bit	Description
15:0	<b>Subsystem ID (SID) — RO.</b> This value may be loaded automatically from the NVM Word 0Ch upon power up depending on the "Load Subsystem ID" bit field in NVM word 0Ah. A value of 8086h is default for this field upon power up if the NVM does not respond or is not programmed. All functions are initialized to the same value.

### 8.1.14 SVID—Subsystem Vendor ID Register (Gigabit LAN—D25:F0)

Address Offset: 2Eh–2Fh                      Attribute: RO  
 Default Value: See bit description              Size: 16 bits

Bit	Description
15:0	<b>Subsystem Vendor ID (SVID) — RO.</b> This value may be loaded automatically from the NVM Word 0Bh upon power up or reset depending on the "Load Subsystem ID" bit field in NVM word 0Ah with a default value of 0000h. This value is loadable from NVM word location 0Bh.



### 8.1.15 ERBA—Expansion ROM Base Address Register (Gigabit LAN—D25:F0)

Address Offset: 30h–33h                      Attribute: RO  
Default Value: See bit description              Size: 32 bits

Bit	Description
31:0	Expansion ROM Base Address (ERBA) — RO. This register is used to define the address and size information for boot-time access to the optional FLASH memory. If no Flash memory exists this register reports 00000000h.

### 8.1.16 CAPP—Capabilities List Pointer Register (Gigabit LAN—D25:F0)

Address Offset: 34h                              Attribute: RO  
Default Value: C8h                              Size: 8 bits

Bit	Description
7:0	<b>Capabilities Pointer (PTR)</b> — RO. This field indicates that the pointer for the first entry in the capabilities list is at C8h in configuration space.

### 8.1.17 INTR—Interrupt Information Register (Gigabit LAN—D25:F0)

Address Offset: 3Ch–3Dh                      Attribute: R/W, RO  
Default Value: 0100h                      Size: 16 bits

Bit	Description
15:8	<b>Interrupt Pin (IPIN)</b> — RO. This field indicates the interrupt pin driven by the Gb LAN controller. 01h = The Gb LAN controller implements legacy interrupts on INTA.
7:0	<b>Interrupt Line (ILINE)</b> — R/W. Default = 00h. Software written value to indicate which interrupt line (vector) the interrupt is connected to. No hardware action is taken on this register.

### 8.1.18 MLMG—Maximum Latency/Minimum Grant Register (Gigabit LAN—D25:F0)

Address Offset: 3Eh                              Attribute: RO  
Default Value: 00h                              Size: 8 bits

Bit	Description
7:0	Maximum Latency/Minimum Grant (MLMG) — RO. Not used. Hardwired to 00h.



### 8.1.19 CLIST 1—Capabilities List Register 1 (Gigabit LAN—D25:F0)

Address Offset: C8h–C9h                      Attribute: RO  
Default Value: D001h                      Size: 16 bits

Bit	Description
15:8	<b>Next Capability (NEXT)</b> — RO. Value of D0h indicates the location of the next pointer.
7:0	<b>Capability ID (CID)</b> — RO. Indicates the linked list item is a PCI Power Management Register.

### 8.1.20 PMC—PCI Power Management Capabilities Register (Gigabit LAN—D25:F0)

Address Offset: CAh–CBh                      Attribute: RO  
Default Value: See bit descriptions                      Size: 16 bits

Bit	Description												
15:11	<p>PME_Support (PMES) — RO. This five-bit field indicates the power states in which the function may assert PME#. It depend on PM Ena and AUX-PWR bits in word 0Ah in the NVM:</p> <table border="1"> <thead> <tr> <th>Condition</th> <th>Functionality</th> <th>Value</th> </tr> </thead> <tbody> <tr> <td>PM Ena=0</td> <td>No PME at all states</td> <td>00000b</td> </tr> <tr> <td>PM Ena &amp; AUX-PWR=0</td> <td>PME at D0 and D3hot</td> <td>01001b</td> </tr> <tr> <td>PM Ena &amp; AUX-PWR=1</td> <td>PME at D0, D3hot and D3cold</td> <td>11001b.</td> </tr> </tbody> </table>	Condition	Functionality	Value	PM Ena=0	No PME at all states	00000b	PM Ena & AUX-PWR=0	PME at D0 and D3hot	01001b	PM Ena & AUX-PWR=1	PME at D0, D3hot and D3cold	11001b.
Condition	Functionality	Value											
PM Ena=0	No PME at all states	00000b											
PM Ena & AUX-PWR=0	PME at D0 and D3hot	01001b											
PM Ena & AUX-PWR=1	PME at D0, D3hot and D3cold	11001b.											
10	D2_Support (D2S) — RO. The D2 state is not supported.												
9	D1_Support (D1S) — RO The D1 state is not supported.												
8:6	Aux_Current (AC) — RO. Required current defined in the Data Register.												
5	Device Specific Initialization (DSI) — RO. Set to 1. The Gb LAN Controller requires its device driver to be executed following transition to the D0 un-initialized state.												
4	Reserved												
3	PME Clock (PMEC) — RO. Hardwired to '0'.												
2:0	Version (VS) — RO. Hardwired to 010b to indicate support for <i>Revision 1.1 of the PCI Power Management Specification</i> .												



### 8.1.21 PMCS—PCI Power Management Control and Status Register (Gigabit LAN—D25:F0)

Address Offset: CCh–CDh                      Attribute:                      R/WC, R/W, RO  
 Default Value:    See bit description                      Size:                      16 bits

Bit	Description
15	<b>PME Status (PMES)</b> — R/WC. This bit is set to 1 when the function detects a wake-up event independent of the state of the PMEE bit. Writing a 1 will clear this bit.
14:13	<b>Data Scale (DSC)</b> — R/W. This field indicates the scaling factor to be used when interpreting the value of the Data register. For the GbE LAN and common functions this field equals 01b (indicating 0.1 watt units) if the PM is enabled in the NVM, and the Data_Select field is set to 0, 3, 4, 7, (or 8 for Function 0). Else it equals 00b. For the manageability functions, this field equals 10b (indicating 0.01 watt units) if the PM is enabled in the NVM, and the Data_Select field is set to 0, 3, 4, 7; otherwise, it equals 00b.
12:9	<b>Data Select (DSL)</b> — R/W. This four-bit field is used to select which data is to be reported through the Data register (offset CFh) and Data_Scale field. These bits are writeable only when the Power Management is enabled via NVM. 0h = D0 Power Consumption 3h = D3 Power Consumption 4h = D0 Power Dissipation 7h = D3 Power Dissipation 8h = Common Power All other values are reserved.
8	<b>PME Enable (PMEE)</b> — R/W. If Power Management is enabled in the NVM, writing a 1 to this register will enable Wakeup. If Power Management is disabled in the NVM, writing a 1 to this bit has no affect, and will not set the bit to 1.
7:2	Reserved - Returns a value of '000000'.
1:0	<b>Power State (PS)</b> — R/W. This field is used both to determine the current power state of the Gb LAN Controller and to set a new power state. The values are: 00 = D0 state (default) 01 = Ignored 10 = Ignored 11 = D3 state (Power Management must be enables in the NVM or this cycle will be ignored).

### 8.1.22 DR—Data Register (Gigabit LAN—D25:F0)

Address Offset: CFh                                      Attribute:                      RO  
 Default Value:    See bit description                      Size:                      8 bits

Bit	Description
7:0	<b>Reported Data (RD)</b> — RO. This register is used to report power consumption and heat dissipation. This register is controlled by the Data_Select field in the PMCS (Offset CCh, bits 12:9), and the power scale is reported in the Data_Scale field in the PMCS (Offset CCh, bits 14:13). The data of this field is loaded from the NVM if PM is enabled in the NVM or with a default value of 0x00 otherwise.



### 8.1.23 CLIST 2—Capabilities List Register 2 (Gigabit LAN—D25:F0)

Address Offset: D0h–D1h                      Attribute:                      RO  
 Default Value: 0005h                      Size:                      16 bits

Bit	Description
15:8	<b>Next Capability (NEXT)</b> — RO. Value of 00h indicates the end of the list.
7:0	<b>Capability ID (CID)</b> — RO. Indicates the linked list item is a Message Signaled Interrupt Register.

### 8.1.24 MCTL—Message Control Register (Gigabit LAN—D25:F0)

Address Offset: D2h–D3h                      Attribute:                      R/W, RO  
 Default Value: 0080h                      Size:                      16 bits

Bit	Description
15:8	Reserved
7	64-bit Capable (CID) — RO. Set to 1 to indicate that the Gb LAN Controller is capable of generating 64-bit message addresses.
6:4	Multiple Message Enable (MME) — RO. Returns 000b to indicate that the Gb LAN controller only supports a single message.
3:1	Multiple Message Capable (MMC) — RO. The Gb LAN controller does not support multiple messages.
0	<b>MSI Enable (MSIE)</b> — R/W. 0 = MSI generation is disabled. 1 = The Gb LAN controller will generate MSI for interrupt assertion instead of INTx signaling.

### 8.1.25 MADDL—Message Address Low Register (Gigabit LAN—D25:F0)

Address Offset: D4h–D7h                      Attribute:                      R/W  
 Default Value: See bit description                      Size:                      32 bits

Bit	Description
31:0	<b>Message Address Low (MADDL)</b> — R/W. This field is written by the system to indicate the lower 32 bits of the address to use for the MSI memory write transaction. The lower two bits will always return 0 regardless of the write operation.



### 8.1.26 MADDH—Message Address High Register (Gigabit LAN—D25:F0)

Address Offset: D8h–DBh                      Attribute: R/W  
Default Value: See bit description              Size: 32 bits

Bit	Description
31:0	<b>Message Address High (MADDH)</b> — R/W. This field is written by the system to indicate the upper 32 bits of the address to use for the MSI memory write transaction.

### 8.1.27 MDAT—Message Data Register (Gigabit LAN—D25:F0)

Address Offset: DCh–DDh                      Attribute: R/W  
Default Value: See bit description              Size: 16 bits

Bit	Description
31:0	<b>Message Data (MDAT)</b> — R/W. This field is written by the system to indicate the lower 16 bits of the data written in the MSI memory write DWord transaction. The upper 16 bits of the transaction are written as 0000h.





## 8.2 GBAR0—Gigabit LAN Base Address Register 0 Registers

### 8.2.1 LDCR1—LAN Device Control Register 1 (Gigabit LAN Memory Mapped Base Address Register)

Address Offset: GBAR0 + 00h                      Attribute:                      R/W, RO  
 Default Value: 00100201h                      Size:                              32 bits

Bit	Description
31:25	Reserved
24	<b>PLCD Power Down (PLCDPD)</b> — R/W. When the bit is cleared to '0', the PLCD power down setting is controlled by the internal logic of the LAN controller. When set to '1' and the LDCR.LPPDE is set as well, the LAN controller sets the external PLCD to power down mode. Further, if the LAN PHY Power Control functionality is implemented, the LAN controller disconnects the LCD power supply (mobile only - see <a href="#">Section 5.3.6</a> ).
23:0	Reserved

### 8.2.2 LDCR2—LAN Device Control Register 2 (Gigabit LAN Memory Mapped Base Address Register)

Address Offset: GBAR0 + 18h                      Attribute:                      R/W, RO  
 Default Value: 001000000h                      Size:                              32 bits

Bit	Description
31:21	Reserved
20	<b>LAN PHY Power Down Enable (LPPDE)</b> — R/W. When set, enables the PHY to enter a low-power state when the LAN controller is at the Moff / D3 no WoL. This bit is loaded from word 13h in the NVM
19:0	Reserved

### 8.2.3 LDR1—LAN Device Initialization Register 1 (Gigabit LAN Memory Mapped Base Address Register)

Address Offset: GBAR0 + 20h                      Attribute:                      R/W, RO  
 Default Value: 1000xxxxh                      Size:                              32 bits

Bit	Description
31:0	<b>LDR1 Field 1</b> — R/W.



### 8.2.4 EXTCNF\_CTRL—Extended Configuration Control Register (Gigabit LAN Memory Mapped Base Address Register)

Address Offset: GBAR0 + F00h                      Attribute: R/W, RO  
Default Value: 000000002h                      Size: 32 bits

Bit	Description
31:6	Reserved
5	<b>SW Semaphore Flag (SWFLAG)</b> — R/W. This bit is set by the device driver to gain access permission to shared CSR registers with the firmware and hardware
4:0	Reserved

### 8.2.5 LDR2—LAN Device Initialization Register 2 (Gigabit LAN Memory Mapped Base Address Register)

Address Offset: GBAR0 + 3004h                      Attribute: R/W  
Default Value: B2B47CCh                      Size: 32 bits

Bit	Description
31:10	Reserved
19:16	<b>LDR2 Field 1</b> — R/W. BIOS must program this field to 0101b.
15:0	Reserved

§ §



## 9 LPC Interface Bridge Registers (D31:F0)

The LPC bridge function of the ICH8 resides in PCI Device 31:Function 0. This function contains many other functional units, such as DMA and Interrupt controllers, Timers, Power Management, System Management, GPIO, RTC, and LPC Configuration Registers.

Registers and functions associated with other functional units (EHCI, UHCI, IDE (Mobile only), etc.) are described in their respective sections.

### 9.1 PCI Configuration Registers (LPC I/F—D31:F0)

**Note:** Address locations that are not shown should be treated as Reserved.

**Table 105. LPC Interface PCI Register Address Map (LPC I/F—D31:F0) (Sheet 1 of 2)**

Offset	Mnemonic	Register Name	Default	Type
00h–01h	VID	Vendor Identification	8086h	RO
02h–03h	DID	Device Identification	See register description	RO
04h–05h	PCICMD	PCI Command	0007h	R/W, RO
06h–07h	PCISTS	PCI Status	0200h	R/WC, RO
08h	RID	Revision Identification	See register description	RO
09h	PI	Programming Interface	00h	RO
0Ah	SCC	Sub Class Code	01h	RO
0Bh	BCC	Base Class Code	06h	RO
0Dh	PLT	Primary Latency Timer	00h	RO
0Eh	HEADTYP	Header Type	80h	RO
2Ch–2Fh	SS	Sub System Identifiers	00000000h	R/WO
40h–43h	PMBASE	ACPI Base Address	00000001h	R/W, RO
44h	ACPI_CNTL	ACPI Control	00h	R/W
48h–4Bh	GPIOBASE	GPIO Base Address	00000001h	R/W, RO
4C	GC	GPIO Control	00h	R/W
60h–63h	PIRQ[n]_ROUT	PIRQ[A–D] Routing Control	80h	R/W
64h	SIRQ_CNTL	Serial IRQ Control	10h	R/W, RO
68h–6Bh	PIRQ[n]_ROUT	PIRQ[E–H] Routing Control	80h	R/W
80h	LPC_I/O_DEC	I/O Decode Ranges	0000h	R/W
82h–83h	LPC_EN	LPC I/F Enables	0000h	R/W
84h–87h	GEN1_DEC	LPC I/F Generic Decode Range 1	00000000h	R/W
88h–8Bh	GEN2_DEC	LPC I/F Generic Decode Range 2	00000000h	R/W
8Ch–8Eh	GEN3_DEC	LPC I/F Generic Decode Range 3	00000000h	R/W



Table 105. LPC Interface PCI Register Address Map (LPC I/F—D31:F0) (Sheet 2 of 2)

Offset	Mnemonic	Register Name	Default	Type
90h–93h	GEN4_DEC	LPC I/F Generic Decode Range 4	00000000h	R/W
A0h–CFh		Power Management (See Section 9.8.1)		
D0h–D3h	FWH_SEL1	Firmware Hub Select 1	00112233h	R/W, RO
D4h–D5h	FWH_SEL2	Firmware Hub Select 2	4567h	R/W
D8h–D9h	FWH_DEC_EN1	Firmware Hub Decode Enable 1	FFCFh	R/W, RO
DCh	BIOS_CNTL	BIOS Control	00h	R/WLO, R/W
E0h–E1h	FD CAP	Feature Detection Capability ID	0000h	RO
E2h	FDLEN	Feature Detection Capability Length	0Ch	RO
E3h	FDVER	Feature Detection Version	10h	RO
E4h–EBh	FDVCT	Feature Vector	See Description	RO
F0h–F3h	RCBA	Root Complex Base Address	00000000h	R/W

### 9.1.1 VID—Vendor Identification Register (LPC I/F—D31:F0)

Offset Address:	00h–01h	Attribute:	RO
Default Value:	8086h	Size:	16-bit
Lockable:	No	Power Well:	Core

Bit	Description
15:0	<b>Vendor ID</b> — RO. This is a 16-bit value assigned to Intel. Intel VID = 8086h

### 9.1.2 DID—Device Identification Register (LPC I/F—D31:F0)

Offset Address:	02h–03h	Attribute:	RO
Default Value:	See bit description	Size:	16-bit
Lockable:	No	Power Well:	Core

Bit	Description
15:0	<b>Device ID</b> — RO. This is a 16-bit value assigned to the Intel® ICH8 LPC bridge. Refer to the Intel ICH8 Family Specification Update for the value of the Device ID Register.



### 9.1.3 PCICMD—PCI COMMAND Register (LPC I/F—D31:F0)

Offset Address: 04h–05h                      Attribute:            R/W, RO  
 Default Value: 0007h                      Size:                 16-bit  
 Lockable:                                        No                      Power Well:        Core

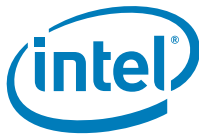
Bit	Description
15:10	Reserved
9	Fast Back to Back Enable (FBE) — RO. Hardwired to 0.
8	<b>SERR# Enable (SERR_EN)</b> — R/W. The LPC bridge generates SERR# if this bit is set.
7	Wait Cycle Control (WCC) — RO. Hardwired to 0.
6	<b>Parity Error Response Enable (PERE)</b> — R/W. 0 = No action is taken when detecting a parity error. 1 = Enables the ICH8 LPC bridge to respond to parity errors detected on backbone interface.
5	VGA Palette Snoop (VPS) — RO. Hardwired to 0.
4	Memory Write and Invalidate Enable (MWIE) — RO. Hardwired to 0.
3	Special Cycle Enable (SCE) — RO. Hardwired to 0.
2	Bus Master Enable (BME) — RO. Bus Masters cannot be disabled.
1	Memory Space Enable (MSE) — RO. Memory space cannot be disabled on LPC.
0	I/O Space Enable (IOSE) — RO. I/O space cannot be disabled on LPC.

### 9.1.4 PCISTS—PCI Status Register (LPC I/F—D31:F0)

Offset Address: 06–07h                      Attribute:            RO, R/WC  
 Default Value: 0210h                      Size:                 16-bit  
 Lockable:                                        Noh                    Power Well:        Core

**Note:** For the writable bits, software must write a 1 to clear bits that are set. Writing a 0 to the bit has no effect.

Bit	Description
15	<b>Detected Parity Error (DPE)</b> — R/WC. Set when the LPC bridge detects a parity error on the internal backbone. Set even if the PCICMD.PERE bit (D31:F0:04, bit 6) is 0. 0 = Parity Error Not detected. 1 = Parity Error detected.
14	<b>Signaled System Error (SSE)</b> — R/WC. Set when the LPC bridge signals a system error to the internal SERR# logic.
13	<b>Master Abort Status (RMA)</b> — R/WC. 0 = Unsupported request status not received. 1 = The bridge received a completion with unsupported request status from the backbone.
12	<b>Received Target Abort (RTA)</b> — R/WC. 0 = Completion abort not received. 1 = Completion with completion abort received from the backbone.



Bit	Description
11	<b>Signaled Target Abort (STA)</b> — R/WC. 0 = Target abort Not generated on the backbone. 1 = LPC bridge generated a completion packet with target abort status on the backbone.
10:9	<b>DEVSEL# Timing Status (DEV_STS)</b> — RO. 01 = Medium Timing.
8	<b>Data Parity Error Detected (DPED)</b> — R/WC. 0 = All conditions listed below Not met. 1 = Set when all three of the following conditions are met: <ul style="list-style-type: none"><li>• LPC bridge receives a completion packet from the backbone from a previous request,</li><li>• Parity error has been detected (D31:F0:06, bit 15)</li><li>• PCICMD.PERE bit (D31:F0:04, bit 6) is set.</li></ul>
7	Fast Back to Back Capable (FBC): Reserved – bit has no meaning on the internal backbone.
6	Reserved.
5	66 MHz Capable (66MHZ_CAP) — Reserved – bit has no meaning on internal backbone.
4	Capabilities List (CLIST) — RO. Capability list exists on the LPC bridge.
3	Interrupt Status (IS) — RO. The LPC bridge does not generate interrupts.
2:0	Reserved.

### 9.1.5 RID—Revision Identification Register (LPC I/F—D31:F0)

Offset Address: 08h                                  Attribute: RO  
Default Value: See bit description                  Size: 8 bits

Bit	Description
7:0	<b>Revision ID (RID)</b> — RO. Refer to the <i>Intel® I/O Controller Hub 8 (ICH8) Family Specification Update</i> for the value of the Revision ID Register

### 9.1.6 PI—Programming Interface Register (LPC I/F—D31:F0)

Offset Address: 09h                                  Attribute: RO  
Default Value: 00h                                    Size: 8 bits

Bit	Description
7:0	<b>Programming Interface</b> — RO.



### 9.1.7 SCC—Sub Class Code Register (LPC I/F—D31:F0)

Offset Address: 0Ah Attribute: RO  
Default Value: 01h Size: 8 bits

Bit	Description
7:0	<b>Sub Class Code</b> — RO. 8-bit value that indicates the category of bridge for the LPC bridge. 01h = PCI-to-ISA bridge.

### 9.1.8 BCC—Base Class Code Register (LPC I/F—D31:F0)

Offset Address: 0Bh Attribute: RO  
Default Value: 06h Size: 8 bits

Bit	Description
7:0	<b>Base Class Code</b> — RO. 8-bit value that indicates the type of device for the LPC bridge. 06h = Bridge device.

### 9.1.9 PLT—Primary Latency Timer Register (LPC I/F—D31:F0)

Offset Address: 0Dh Attribute: RO  
Default Value: 00h Size: 8 bits

Bit	Description
7:3	Master Latency Count (MLC) — Reserved.
2:0	Reserved.

### 9.1.10 HEADTYP—Header Type Register (LPC I/F—D31:F0)

Offset Address: 0Eh Attribute: RO  
Default Value: 80h Size: 8 bits

Bit	Description
7	Multi-Function Device — RO. This bit is 1 to indicate a multi-function device.
6:0	Header Type — RO. This 7-bit field identifies the header layout of the configuration space.



### 9.1.11 SS—Sub System Identifiers Register (LPC I/F—D31:F0)

Offset Address: 2Ch–2Fh                      Attribute: R/WO  
Default Value: 00000000h                  Size: 32 bits

This register is initialized to logic 0 by the assertion of PLTRST#. This register can be written only once after PLTRST# de-assertion.

Bit	Description
31:16	<b>Subsystem ID (SSID)</b> — R/WO This is written by BIOS. No hardware action taken on this value.
15:0	<b>Subsystem Vendor ID (SSVID)</b> — R/WO This is written by BIOS. No hardware action taken on this value.

### 9.1.12 PMBASE—ACPI Base Address Register (LPC I/F—D31:F0)

Offset Address: 40h–43h                      Attribute: R/W, RO  
Default Value: 00000001h                  Size: 32 bit  
Lockable: No                                  Usage: ACPI, Legacy  
Power Well: Core

Sets base address for ACPI I/O registers, GPIO registers and TCO I/O registers. These registers can be mapped anywhere in the 64-K I/O space on 128-byte boundaries.

Bit	Description
31:16	Reserved
15:7	<b>Base Address</b> — R/W. This field provides 128 bytes of I/O space for ACPI, GPIO, and TCO logic. This is placed on a 128-byte boundary.
6:1	Reserved
0	<b>Resource Type Indicator (RTE)</b> — RO. Hardwired to 1 to indicate I/O space.





### 9.1.13 ACPI\_CNTL—ACPI Control Register (LPC I/F — D31:F0)

Offset Address:	44h	Attribute:	R/W
Default Value:	00h	Size:	8 bit
Lockable:	No	Usage:	ACPI, Legacy
		Power Well:	Core

Bit	Description																		
7	<p><b>ACPI Enable (ACPI_EN)</b> — R/W.</p> <p>0 = Disable.</p> <p>1 = Decode of the I/O range pointed to by the ACPI base register is enabled, and the ACPI power management function is enabled. Note that the APM power management ranges (B2/B3h) are always enabled and are not affected by this bit.</p>																		
6:3	Reserved																		
2:0	<p><b>SCI IRQ Select (SCI_IRQ_SEL)</b> — R/W. This field specifies on which IRQ the SCI will internally appear. If not using the APIC, the SCI must be routed to IRQ9–11, and that interrupt is not sharable with the SERIRQ stream, but is shareable with other PCI interrupts. If using the APIC, the SCI can also be mapped to IRQ20–23, and can be shared with other interrupts.</p> <table border="1"> <thead> <tr> <th>Bits</th> <th>SCI Map</th> </tr> </thead> <tbody> <tr> <td>000b</td> <td>IRQ9</td> </tr> <tr> <td>001b</td> <td>IRQ10</td> </tr> <tr> <td>010b</td> <td>IRQ11</td> </tr> <tr> <td>011b</td> <td>Reserved</td> </tr> <tr> <td>100b</td> <td>IRQ20 (Only available if APIC enabled)</td> </tr> <tr> <td>101b</td> <td>IRQ21 (Only available if APIC enabled)</td> </tr> <tr> <td>110b</td> <td>IRQ22 (Only available if APIC enabled)</td> </tr> <tr> <td>111b</td> <td>IRQ23 (Only available if APIC enabled)</td> </tr> </tbody> </table> <p><b>NOTE:</b> When the interrupt is mapped to APIC interrupts 9, 10 or 11, the APIC should be programmed for active-high reception. When the interrupt is mapped to APIC interrupts 20 through 23, the APIC should be programmed for active-low reception.</p>	Bits	SCI Map	000b	IRQ9	001b	IRQ10	010b	IRQ11	011b	Reserved	100b	IRQ20 (Only available if APIC enabled)	101b	IRQ21 (Only available if APIC enabled)	110b	IRQ22 (Only available if APIC enabled)	111b	IRQ23 (Only available if APIC enabled)
Bits	SCI Map																		
000b	IRQ9																		
001b	IRQ10																		
010b	IRQ11																		
011b	Reserved																		
100b	IRQ20 (Only available if APIC enabled)																		
101b	IRQ21 (Only available if APIC enabled)																		
110b	IRQ22 (Only available if APIC enabled)																		
111b	IRQ23 (Only available if APIC enabled)																		

### 9.1.14 GPIOBASE—GPIO Base Address Register (LPC I/F — D31:F0)

Offset Address:	48h–4Bh	Attribute:	R/W, RO
Default Value:	00000001h	Size:	32 bit

Bit	Description
31:16	Reserved. Always 0.
15:6	<b>Base Address (BA)</b> — R/W. Provides the 64 bytes of I/O space for GPIO.
5:1	Reserved. Always 0.
0	RO. Hardwired to 1 to indicate I/O space.



### 9.1.15 GC—GPIO Control Register (LPC I/F — D31:F0)

Offset Address: 4Ch Attribute: R/W  
 Default Value: 00h Size: 8 bit

Bit	Description
7:5	Reserved.
4	<b>GPIO Enable (EN)</b> — R/W. This bit enables/disables decode of the I/O range pointed to by the GPIO Base Address register (D31:F0:48h) and enables the GPIO function. 0 = Disable. 1 = Enable.
3:0	Reserved.

### 9.1.16 PIRQ[n]\_ROUT—PIRQ[A,B,C,D] Routing Control Register (LPC I/F—D31:F0)

Offset Address: PIRQA – 60h, PIRQB – 61h, Attribute: R/W  
 PIRQC – 62h, PIRQD – 63h  
 Default Value: 80h Size: 8 bit  
 Lockable: No Power Well: Core

Bit	Description																																				
7	<b>Interrupt Routing Enable (IRQEN)</b> — R/W. 0 = The corresponding PIRQ is routed to one of the ISA-compatible interrupts specified in bits[3:0]. 1 = The PIRQ is not routed to the 8259.  <b>NOTE:</b> BIOS must program this bit to 0 during POST for any of the PIRQs that are being used. The value of this bit may subsequently be changed by the OS when setting up for I/O APIC interrupt delivery mode.																																				
6:4	Reserved																																				
3:0	<b>IRQ Routing</b> — R/W. (ISA compatible.)  <table border="1"> <thead> <tr> <th>Value</th> <th>IRQ</th> <th>Value</th> <th>IRQ</th> </tr> </thead> <tbody> <tr> <td>0000b</td> <td>Reserved</td> <td>1000b</td> <td>Reserved</td> </tr> <tr> <td>0001b</td> <td>Reserved</td> <td>1001b</td> <td>IRQ9</td> </tr> <tr> <td>0010b</td> <td>Reserved</td> <td>1010b</td> <td>IRQ10</td> </tr> <tr> <td>0011b</td> <td>IRQ3</td> <td>1011b</td> <td>IRQ11</td> </tr> <tr> <td>0100b</td> <td>IRQ4</td> <td>1100b</td> <td>IRQ12</td> </tr> <tr> <td>0101b</td> <td>IRQ5</td> <td>1101b</td> <td>Reserved</td> </tr> <tr> <td>0110b</td> <td>IRQ6</td> <td>1110b</td> <td>IRQ14</td> </tr> <tr> <td>0111b</td> <td>IRQ7</td> <td>1111b</td> <td>IRQ15</td> </tr> </tbody> </table>	Value	IRQ	Value	IRQ	0000b	Reserved	1000b	Reserved	0001b	Reserved	1001b	IRQ9	0010b	Reserved	1010b	IRQ10	0011b	IRQ3	1011b	IRQ11	0100b	IRQ4	1100b	IRQ12	0101b	IRQ5	1101b	Reserved	0110b	IRQ6	1110b	IRQ14	0111b	IRQ7	1111b	IRQ15
Value	IRQ	Value	IRQ																																		
0000b	Reserved	1000b	Reserved																																		
0001b	Reserved	1001b	IRQ9																																		
0010b	Reserved	1010b	IRQ10																																		
0011b	IRQ3	1011b	IRQ11																																		
0100b	IRQ4	1100b	IRQ12																																		
0101b	IRQ5	1101b	Reserved																																		
0110b	IRQ6	1110b	IRQ14																																		
0111b	IRQ7	1111b	IRQ15																																		



**9.1.17 SIRQ\_CNTL—Serial IRQ Control Register (LPC I/F—D31:F0)**

Offset Address:	64h	Attribute:	R/W, RO
Default Value:	10h	Size:	8 bit
Lockable:	No	Power Well:	Core

Bit	Description
7	<b>Serial IRQ Enable (SIRQEN) — R/W.</b> 0 = The buffer is input only and internally SERIRQ will be a 1. 1 = Serial IRQs will be recognized. The SERIRQ pin will be configured as SERIRQ.
6	<b>Serial IRQ Mode Select (SIRQMD) — R/W.</b> 0 = The serial IRQ machine will be in quiet mode. 1 = The serial IRQ machine will be in continuous mode.  <b>NOTE:</b> For systems using Quiet Mode, this bit should be set to 1 (Continuous Mode) for at least one frame after coming out of reset before switching back to Quiet Mode. Failure to do so will result in the ICH8 not recognizing SERIRQ interrupts.
5:2	<b>Serial IRQ Frame Size (SIRQSZ) — RO.</b> Fixed field that indicates the size of the SERIRQ frame as 21 frames.
1:0	<b>Start Frame Pulse Width (SFPW) — R/W.</b> This is the number of PCI clocks that the SERIRQ pin will be driven low by the serial IRQ machine to signal a start frame. In continuous mode, the ICH8 will drive the start frame for the number of clocks specified. In quiet mode, the ICH8 will drive the start frame for the number of clocks specified minus one, as the first clock was driven by the peripheral. 00 = 4 clocks 01 = 6 clocks 10 = 8 clocks 11 = Reserved



### 9.1.18 PIRQ[n]\_ROUT—PIRQ[E,F,G,H] Routing Control Register (LPC I/F—D31:F0)

Offset Address: PIRQE – 68h, PIRQF – 69h, Attribute: R/W  
 PIRQG – 6Ah, PIRQH – 6Bh  
 Default Value: 80h Size: 8 bit  
 Lockable: No Power Well: Core

Bit	Description																																				
7	<p><b>Interrupt Routing Enable (IRQEN)</b> — R/W.</p> <p>0 = The corresponding PIRQ is routed to one of the ISA-compatible interrupts specified in bits[3:0].</p> <p>1 = The PIRQ is not routed to the 8259.</p> <p><b>NOTE:</b> BIOS must program this bit to 0 during POST for any of the PIRQs that are being used. The value of this bit may subsequently be changed by the OS when setting up for I/O APIC interrupt delivery mode.</p>																																				
6:4	Reserved																																				
3:0	<p><b>IRQ Routing</b> — R/W. (ISA compatible.)</p> <table border="1"> <thead> <tr> <th>Value</th> <th>IRQ</th> <th>Value</th> <th>IRQ</th> </tr> </thead> <tbody> <tr> <td>0000b</td> <td>Reserved</td> <td>1000b</td> <td>Reserved</td> </tr> <tr> <td>0001b</td> <td>Reserved</td> <td>1001b</td> <td>IRQ9</td> </tr> <tr> <td>0010b</td> <td>Reserved</td> <td>1010b</td> <td>IRQ10</td> </tr> <tr> <td>0011b</td> <td>IRQ3</td> <td>1011b</td> <td>IRQ11</td> </tr> <tr> <td>0100b</td> <td>IRQ4</td> <td>1100b</td> <td>IRQ12</td> </tr> <tr> <td>0101b</td> <td>IRQ5</td> <td>1101b</td> <td>Reserved</td> </tr> <tr> <td>0110b</td> <td>IRQ6</td> <td>1110b</td> <td>IRQ14</td> </tr> <tr> <td>0111b</td> <td>IRQ7</td> <td>1111b</td> <td>IRQ15</td> </tr> </tbody> </table>	Value	IRQ	Value	IRQ	0000b	Reserved	1000b	Reserved	0001b	Reserved	1001b	IRQ9	0010b	Reserved	1010b	IRQ10	0011b	IRQ3	1011b	IRQ11	0100b	IRQ4	1100b	IRQ12	0101b	IRQ5	1101b	Reserved	0110b	IRQ6	1110b	IRQ14	0111b	IRQ7	1111b	IRQ15
Value	IRQ	Value	IRQ																																		
0000b	Reserved	1000b	Reserved																																		
0001b	Reserved	1001b	IRQ9																																		
0010b	Reserved	1010b	IRQ10																																		
0011b	IRQ3	1011b	IRQ11																																		
0100b	IRQ4	1100b	IRQ12																																		
0101b	IRQ5	1101b	Reserved																																		
0110b	IRQ6	1110b	IRQ14																																		
0111b	IRQ7	1111b	IRQ15																																		



### 9.1.19 LPC\_I/O\_DEC—I/O Decode Ranges Register (LPC I/F—D31:F0)

Offset Address: 80h  
Default Value: 0000h

Attribute: R/W  
Size: 16 bit

Bit	Description
15:13	Reserved
12	<b>FDD Decode Range</b> — R/W. Determines which range to decode for the FDD Port 0 = 3F0h – 3F5h, 3F7h (Primary) 1 = 370h – 375h, 377h (Secondary)
11:10	Reserved
9:8	<b>LPT Decode Range</b> — R/W. This field determines which range to decode for the LPT Port. 00 = 378h – 37Fh and 778h – 77Fh 01 = 278h – 27Fh (port 279h is read only) and 678h – 67Fh 10 = 3BCh – 3BEh and 7BCh – 7BEh 11 = Reserved
7	Reserved
6:4	<b>COMB Decode Range</b> — R/W. This field determines which range to decode for the COMB Port. 000 = 3F8h – 3FFh (COM1) 001 = 2F8h – 2FFh (COM2) 010 = 220h – 227h 011 = 228h – 22Fh 100 = 238h – 23Fh 101 = 2E8h – 2EFh (COM4) 110 = 338h – 33Fh 111 = 3E8h – 3EFh (COM3)
3	Reserved
2:0	<b>COMA Decode Range</b> — R/W. This field determines which range to decode for the COMA Port. 000 = 3F8h – 3FFh (COM1) 001 = 2F8h – 2FFh (COM2) 010 = 220h – 227h 011 = 228h – 22Fh 100 = 238h – 23Fh 101 = 2E8h – 2EFh (COM4) 110 = 338h – 33Fh 111 = 3E8h – 3EFh (COM3)



### 9.1.20 LPC\_EN—LPC I/F Enables Register (LPC I/F—D31:F0)

Offset Address: 82h – 83h  
 Default Value: 0000h

Attribute: R/W  
 Size: 16 bit  
 Power Well: Core

Bit	Description
15:14	Reserved
13	<b>CNF2_LPC_EN</b> — R/W. Microcontroller Enable # 2. 0 = Disable. 1 = Enables the decoding of the I/O locations 4Eh and 4Fh to the LPC interface. This range is used for a microcontroller.
12	<b>CNF1_LPC_EN</b> — R/W. Super I/O Enable. 0 = Disable. 1 = Enables the decoding of the I/O locations 2Eh and 2Fh to the LPC interface. This range is used for Super I/O devices.
11	<b>MC_LPC_EN</b> — R/W. Microcontroller Enable # 1. 0 = Disable. 1 = Enables the decoding of the I/O locations 62h and 66h to the LPC interface. This range is used for a microcontroller.
10	<b>KBC_LPC_EN</b> — R/W. Keyboard Enable. 0 = Disable. 1 = Enables the decoding of the I/O locations 60h and 64h to the LPC interface. This range is used for a microcontroller.
9	<b>GAMEH_LPC_EN</b> — R/W. High Gameport Enable 0 = Disable. 1 = Enables the decoding of the I/O locations 208h to 20Fh to the LPC interface. This range is used for a gameport.
8	<b>GAMEL_LPC_EN</b> — R/W. Low Gameport Enable 0 = Disable. 1 = Enables the decoding of the I/O locations 200h to 207h to the LPC interface. This range is used for a gameport.
7:4	Reserved
3	<b>FDD_LPC_EN</b> — R/W. Floppy Drive Enable 0 = Disable. 1 = Enables the decoding of the FDD range to the LPC interface. This range is selected in the LPC_FDD/LPT Decode Range Register (D31:F0:80h, bit 12).
2	<b>LPT_LPC_EN</b> — R/W. Parallel Port Enable 0 = Disable. 1 = Enables the decoding of the LPT range to the LPC interface. This range is selected in the LPC_FDD/LPT Decode Range Register (D31:F0:80h, bit 9:8).
1	<b>COMB_LPC_EN</b> — R/W. Com Port B Enable 0 = Disable. 1 = Enables the decoding of the COMB range to the LPC interface. This range is selected in the LPC_COM Decode Range Register (D31:F0:80h, bits 6:4).
0	<b>COMA_LPC_EN</b> — R/W. Com Port A Enable 0 = Disable. 1 = Enables the decoding of the COMA range to the LPC interface. This range is selected in the LPC_COM Decode Range Register (D31:F0:80h, bits 3:2).



### 9.1.21 GEN1\_DEC—LPC I/F Generic Decode Range 1 Register (LPC I/F—D31:F0)

Offset Address: 84h – 87h                      Attribute: R/W  
 Default Value: 00000000h                    Size: 32 bit  
    Power Well: Core

Bit	Description
31:24	Reserved
23:18	<b>Generic I/O Decode Range Address[7:2] Mask:</b> A '1' in any bit position indicates that any value in the corresponding address bit in a received cycle will be treated as a match. The corresponding bit in the Address field, below, is ignored. The mask is only provided for the lower 6 bits of the DWord address, allowing for decoding blocks up to 256 bytes in size.
17:16	Reserved
15:2	<b>Generic I/O Decode Range 1 Base Address (GEN1_BASE)</b> — R/W. This address is aligned on a 128-byte boundary, and must have address lines 31:16 as 0. <b>NOTE:</b> The ICH8 Does not provide decode down to the word or byte level
1	Reserved
0	<b>Generic Decode Range 1 Enable (GEN1_EN)</b> — R/W. 0 = Disable. 1 = Enable the GEN1 I/O range to be forwarded to the LPC I/F

### 9.1.22 GEN2\_DEC—LPC I/F Generic Decode Range 2 Register (LPC I/F—D31:F0)

Offset Address: 88h – 8Bh                      Attribute: R/W  
 Default Value: 00000000h                    Size: 32 bit  
    Power Well: Core

Bit	Description
31:24	Reserved
23:18	<b>Generic I/O Decode Range Address[7:2] Mask:</b> A '1' in any bit position indicates that any value in the corresponding address bit in a received cycle will be treated as a match. The corresponding bit in the Address field, below, is ignored. The mask is only provided for the lower 6 bits of the DWord address, allowing for decoding blocks up to 256 bytes in size.
17:16	Reserved
15:2	<b>Generic I/O Decode Range 2 Base Address (GEN1_BASE)</b> — R/W. <b>NOTE:</b> The ICH8 Does not provide decode down to the word or byte level
1	Reserved
0	<b>Generic Decode Range 2 Enable (GEN2_EN)</b> — R/W. 0 = Disable. 1 = Enable the GEN2 I/O range to be forwarded to the LPC I/F



### 9.1.23 GEN3\_DEC—LPC I/F Generic Decode Range 3 Register (LPC I/F—D31:F0)

Offset Address: 8Ch – 8Eh  
 Default Value: 00000000h

Attribute: R/W  
 Size: 32 bit  
 Power Well: Core

Bit	Description
31:24	Reserved
23:18	<b>Generic I/O Decode Range Address[7:2] Mask:</b> A '1' in any bit position indicates that any value in the corresponding address bit in a received cycle will be treated as a match. The corresponding bit in the Address field, below, is ignored. The mask is only provided for the lower 6 bits of the DWord address, allowing for decoding blocks up to 256 bytes in size.
17:16	Reserved
15:2	<b>Generic I/O Decode Range 3Base Address (GEN3_BASE)</b> — R/W. <b>NOTE:</b> The ICH8 Does not provide decode down to the word or byte level
1	Reserved
0	<b>Generic Decode Range 3Enable (GEN3_EN)</b> — R/W. 0 = Disable. 1 = Enable the GEN3 I/O range to be forwarded to the LPC I/F

### 9.1.24 GEN4\_DEC—LPC I/F Generic Decode Range 4 Register (LPC I/F—D31:F0)

Offset Address: 90h – 93h  
 Default Value: 00000000h

Attribute: R/W  
 Size: 32 bit  
 Power Well: Core

Bit	Description
31:24	Reserved
23:18	<b>Generic I/O Decode Range Address[7:2] Mask:</b> A 1 in any bit position indicates that any value in the corresponding address bit in a received cycle will be treated as a match. The corresponding bit in the Address field, below, is ignored. The mask is only provided for the lower 6 bits of the DWord address, allowing for decoding blocks up to 256 bytes in size.
17:16	Reserved
15:2	<b>Generic I/O Decode Range 4Base Address (GEN4_BASE)</b> — R/W. <b>NOTE:</b> The ICH8 Does not provide decode down to the word or byte level
1	Reserved
0	<b>Generic Decode Range 4Enable (GEN4_EN)</b> — R/W. 0 = Disable. 1 = Enable the GEN4 I/O range to be forwarded to the LPC I/F





### 9.1.25 FWH\_SEL1—Firmware Hub Select 1 Register (LPC I/F—D31:F0)

Offset Address: D0h–D3h  
Default Value: 00112233h

Attribute: R/W, RO  
Size: 32 bits

Bit	Description
31:28	<b>FWH_F8_IDSEL</b> — RO. IDSEL for two 512-KB Firmware Hub memory ranges and one 128-KB memory range. This field is fixed at 0000. The IDSEL programmed in this field addresses the following memory ranges: FFF8 0000h – FFFF FFFFh FFB8 0000h – FFBF FFFFh 000E 0000h – 000F FFFFh
27:24	<b>FWH_F0_IDSEL</b> — R/W. IDSEL for two 512-KB Firmware Hub memory ranges. The IDSEL programmed in this field addresses the following memory ranges: FFF0 0000h – FFF7 FFFFh FFB0 0000h – FFB7 FFFFh
23:20	<b>FWH_E8_IDSEL</b> — R/W. IDSEL for two 512-KB Firmware Hub memory ranges. The IDSEL programmed in this field addresses the following memory ranges: FFE8 0000h – FFEF FFFFh FFA8 0000h – FFAF FFFFh
19:16	<b>FWH_E0_IDSEL</b> — R/W. IDSEL for two 512-KB Firmware Hub memory ranges. The IDSEL programmed in this field addresses the following memory ranges: FFE0 0000h – FFE7 FFFFh FFA0 0000h – FFA7 FFFFh
15:12	<b>FWH_D8_IDSEL</b> — R/W. IDSEL for two 512-KB Firmware Hub memory ranges. The IDSEL programmed in this field addresses the following memory ranges: FFD8 0000h – FFD7 FFFFh FF98 0000h – FF9F FFFFh
11:8	<b>FWH_D0_IDSEL</b> — R/W. IDSEL for two 512-KB Firmware Hub memory ranges. The IDSEL programmed in this field addresses the following memory ranges: FFD0 0000h – FFD7 FFFFh FF90 0000h – FF97 FFFFh
7:4	<b>FWH_C8_IDSEL</b> — R/W. IDSEL for two 512-KB Firmware Hub memory ranges. The IDSEL programmed in this field addresses the following memory ranges: FFC8 0000h – FFC7 FFFFh FF88 0000h – FF8F FFFFh
3:0	<b>FWH_C0_IDSEL</b> — R/W. IDSEL for two 512-KB Firmware Hub memory ranges. The IDSEL programmed in this field addresses the following memory ranges: FFC0 0000h – FFC7 FFFFh FF80 0000h – FF87 FFFFh



### 9.1.26 FWH\_SEL2—Firmware Hub Select 2 Register (LPC I/F—D31:F0)

Offset Address: D4h–D5h                      Attribute: R/W  
 Default Value: 4567h                      Size: 16 bits

Bit	Description
15:12	<b>FWH_70_IDSEL</b> — R/W. IDSEL for two, 1-M Firmware Hub memory ranges. The IDSEL programmed in this field addresses the following memory ranges: FF70 0000h – FF7F FFFFh FF30 0000h – FF3F FFFFh
11:8	<b>FWH_60_IDSEL</b> — R/W. IDSEL for two, 1-M Firmware Hub memory ranges. The IDSEL programmed in this field addresses the following memory ranges: FF60 0000h – FF6F FFFFh FF20 0000h – FF2F FFFFh
7:4	<b>FWH_50_IDSEL</b> — R/W. IDSEL for two, 1-M Firmware Hub memory ranges. The IDSEL programmed in this field addresses the following memory ranges: FF50 0000h – FF5F FFFFh FF10 0000h – FF1F FFFFh
3:0	<b>FWH_40_IDSEL</b> — R/W. IDSEL for two, 1-M Firmware Hub memory ranges. The IDSEL programmed in this field addresses the following memory ranges: FF40 0000h – FF4F FFFFh FF00 0000h – FF0F FFFFh

### 9.1.27 FWH\_DEC\_EN1—Firmware Hub Decode Enable Register (LPC I/F—D31:F0)

Offset Address: D8h–D9h                      Attribute: R/W, RO  
 Default Value: FFCFh                      Size: 16 bits

Bit	Description
15	<b>FWH_F8_EN</b> — RO. This bit enables decoding two 512-KB Firmware Hub memory ranges, and one 128-KB memory range. 0 = Disable 1 = Enable the following ranges for the Firmware Hub FFF80000h – FFFFFFFFh FFB80000h – FFBFFFFFFh
14	<b>FWH_F0_EN</b> — R/W. This bit enables decoding two 512-KB Firmware Hub memory ranges. 0 = Disable. 1 = Enable the following ranges for the Firmware Hub: FFF00000h – FFF7FFFFh FFB00000h – FFB7FFFFh
13	<b>FWH_E8_EN</b> — R/W. This bit enables decoding two 512-KB Firmware Hub memory ranges. 0 = Disable. 1 = Enable the following ranges for the Firmware Hub: FFE80000h – FFEFFFFFFh FFA80000h – FFAFFFFFFh



Bit	Description
12	<b>FWH_EO_EN</b> — R/W. This bit enables decoding two 512-KB Firmware Hub memory ranges. 0 = Disable. 1 = Enable the following ranges for the Firmware Hub: FFE00000h – FFE7FFFFh FFA00000h – FFA7FFFFh
11	<b>FWH_D8_EN</b> — R/W. This bit enables decoding two 512-KB Firmware Hub memory ranges. 0 = Disable. 1 = Enable the following ranges for the Firmware Hub FFD80000h – FFDFFFFFFh FF980000h – FF9FFFFFFh
10	<b>FWH_DO_EN</b> — R/W. This bit enables decoding two 512-KB Firmware Hub memory ranges. 0 = Disable. 1 = Enable the following ranges for the Firmware Hub FFD00000h – FFD7FFFFh FF900000h – FF97FFFFh
9	<b>FWH_C8_EN</b> — R/W. This bit enables decoding two 512-KB Firmware Hub memory ranges. 0 = Disable. 1 = Enable the following ranges for the Firmware Hub FFC80000h – FFCFFFFFFh FF880000h – FF8FFFFFFh
8	<b>FWH_CO_EN</b> — R/W. This bit enables decoding two 512-KB Firmware Hub memory ranges. 0 = Disable. 1 = Enable the following ranges for the Firmware Hub FFC00000h – FFC7FFFFh FF800000h – FF87FFFFh
7	<b>FWH_Legacy_F_EN</b> — R/W. This enables the decoding of the legacy 128-K range at F0000h – FFFFFh. 0 = Disable. 1 = Enable the following legacy ranges for the Firmware Hub F0000h – FFFFFh
6	<b>FWH_Legacy_E_EN</b> — R/W. This enables the decoding of the legacy 128-K range at E0000h – EFFFFh. 0 = Disable. 1 = Enable the following legacy ranges for the Firmware Hub E0000h – EFFFFh
5:4	Reserved
3	<b>FWH_70_EN</b> — R/W. Enables decoding two 1-M Firmware Hub memory ranges. 0 = Disable. 1 = Enable the following ranges for the Firmware Hub FF70 0000h – FF7F FFFFh FF30 0000h – FF3F FFFFh



Bit	Description
2	<b>FWH_60_EN</b> — R/W. Enables decoding two 1-M Firmware Hub memory ranges. 0 = Disable. 1 = Enable the following ranges for the Firmware Hub FF60 0000h – FF6F FFFFh FF20 0000h – FF2F FFFFh
1	<b>FWH_50_EN</b> — R/W. Enables decoding two 1-M Firmware Hub memory ranges. 0 = Disable. 1 = Enable the following ranges for the Firmware Hub FF50 0000h – FF5F FFFFh FF10 0000h – FF1F FFFFh
0	<b>FWH_40_EN</b> — R/W. Enables decoding two 1-M Firmware Hub memory ranges. 0 = Disable. 1 = Enable the following ranges for the Firmware Hub FF40 0000h – FF4F FFFFh FF00 0000h – FF0F FFFFh

**Note:** This register effects the BIOS decode regardless of whether the BIOS is resident on LPC or SPI. The concept of Feature Space does not apply to SPI-based flash. The ICH8 simply decodes these ranges as memory accesses when enabled for the SPI flash interface.



## 9.1.28 BIOS\_CNTL—BIOS Control Register (LPC I/F—D31:F0)

Offset Address:	DCh	Attribute:	R/WLO, R/W, RO
Default Value:	00h	Size:	8 bit
Lockable:	No	Power Well:	Core

Bit	Description										
7:5	Reserved										
4	<b>Top Swap Status (TSS)</b> — RO: This bit provides a read-only path to view the state of the Top Swap bit that is at offset 3414h, bit 0.										
3:2	<p><b>SPI Read Configuration (SRC)</b>— R/W: This 2-bit field controls two policies related to BIOS reads on the SPI interface:</p> <p>Bit 3- Prefetch Enable Bit 2- Cache Disable</p> <p>Settings are summarized below:</p> <table border="1"> <thead> <tr> <th>Bits 3:2</th> <th>Description</th> </tr> </thead> <tbody> <tr> <td>00b</td> <td><b>No prefetching, but caching enabled.</b> 64B demand reads load the read buffer cache with “valid” data, allowing repeated code fetches to the same line to complete quickly</td> </tr> <tr> <td>01b</td> <td><b>No prefetching and no caching.</b> One-to-one correspondence of host BIOS reads to SPI cycles. This value can be used to invalidate the cache.</td> </tr> <tr> <td>10b</td> <td><b>Prefetching and Caching enabled.</b> This mode is used for long sequences of short reads to consecutive addresses (i.e., shadowing).</td> </tr> <tr> <td>11b</td> <td><b>Reserved. This is an invalid configuration,</b> caching must be enabled when prefetching is enabled.</td> </tr> </tbody> </table>	Bits 3:2	Description	00b	<b>No prefetching, but caching enabled.</b> 64B demand reads load the read buffer cache with “valid” data, allowing repeated code fetches to the same line to complete quickly	01b	<b>No prefetching and no caching.</b> One-to-one correspondence of host BIOS reads to SPI cycles. This value can be used to invalidate the cache.	10b	<b>Prefetching and Caching enabled.</b> This mode is used for long sequences of short reads to consecutive addresses (i.e., shadowing).	11b	<b>Reserved. This is an invalid configuration,</b> caching must be enabled when prefetching is enabled.
Bits 3:2	Description										
00b	<b>No prefetching, but caching enabled.</b> 64B demand reads load the read buffer cache with “valid” data, allowing repeated code fetches to the same line to complete quickly										
01b	<b>No prefetching and no caching.</b> One-to-one correspondence of host BIOS reads to SPI cycles. This value can be used to invalidate the cache.										
10b	<b>Prefetching and Caching enabled.</b> This mode is used for long sequences of short reads to consecutive addresses (i.e., shadowing).										
11b	<b>Reserved. This is an invalid configuration,</b> caching must be enabled when prefetching is enabled.										
1	<p><b>BIOS Lock Enable (BLE)</b> — R/WLO.</p> <p>0 = Setting the BIOSWE will not cause SMIs. 1 = Enables setting the BIOSWE bit to cause SMIs. Once set, this bit can only be cleared by a PLTRST#</p>										
0	<p><b>BIOS Write Enable (BIOSWE)</b> — R/W.</p> <p>0 = Only read cycles result in Firmware Hub I/F cycles. 1 = Access to the BIOS space is enabled for both read and write cycles. When this bit is written from a 0 to a 1 and BIOS Lock Enable (BLE) is also set, an SMI# is generated. This ensures that only SMI code can update BIOS.</p>										

## 9.1.29 FDCAP—Feature Detection Capability ID (LPC I/F—D31:F0)

Offset Address:	E0h-E1h	Attribute:	RO
Default Value:	0000h	Size:	16 bit
		Power Well:	Core

Bit	Description
15:8	Next Item Pointer (NEXT): Configuration offset of the next Capability Item. 00h indicates the last item in the Capability List.
7:0	Capability ID: Indicates a Vendor Specific Capability



### 9.1.30 FDLEN—Feature Detection Capability Length (LPC I/F—D31:F0)

Offset Address: E2h  
Default Value: 0Ch

Attribute: RO  
Size: 8 bit  
Power Well: Core

Bit	Description
7:0	Capability Length: Indicates the length of this Vendor Specific capability, as required by PCI Spec.

### 9.1.31 FDVER—Feature Detection Version (LPC I/F—D31:F0)

Offset Address: E3h  
Default Value: 10h

Attribute: RO  
Size: 8 bit  
Power Well: Core

Bit	Description
7:4	Vendor-Specific Capability ID: A value of 1h in this 4-bit field identifies this Capability as Feature Detection Type. This field allows software to differentiate the Feature Detection Capability from other Vendor-Specific capabilities
3:0	Capability Version: This field indicates the version of the Feature Detection capability

### 9.1.32 FDVCT—Feature Vector (LPC I/F—D31:F0)

Offset Address: E4h-EBh  
Default Value: See Description

Attribute: RO  
Size: 64 bit  
Power Well: Core

Bit	Description
63:40	Reserved
39 (ICH8DH Only)	Quick Resume Technology Capability— RO: 0 = Capable 1 = Disabled
39 (ICH8 Base, ICH8R, ICH8DO, <b>Mobile</b> Only)	Reserved
38:19	Reserved
18	SATA RAID 5 Capability— RO: 0 = Capable 1 = Disabled
17:10	Reserved



Bit	Description
9 (Mobile Only)	Mobile Features Capability— RO: 0 = Disabled 1 = Capable
9 (Desktop Only)	Reserved
8	Reserved
7	PCI Express* 6 x1 Capability— RO: 0 = Capable 1 = Disabled – 4 PCI Express x1 Ports available
6	Reserved
5	SATA RAID 0/1/10 Capability— RO: 0 = Capable 1 = Disabled
4	Reserved
3	SATA AHCI Capability— RO: 0 = Capable 1 = Disabled
2:0	Reserved

### 9.1.33 RCBA—Root Complex Base Address Register (LPC I/F—D31:F0)

Offset Address: F0h  
Default Value: 00000000h

Attribute: R/W  
Size: 32 bit

Bit	Description
31:14	<b>Base Address (BA)</b> — R/W. Base Address for the root complex register block decode range. This address is aligned on a 16-KB boundary.
13:1	Reserved
0	<b>Enable (EN)</b> — R/W. When set, enables the range specified in BA to be claimed as the Root Complex Register Block.



## 9.2 DMA I/O Registers (LPC I/F—D31:F0)

Table 106. DMA Registers (Sheet 1 of 2)

Port	Alias	Register Name	Default	Type
00h	10h	Channel 0 DMA Base & Current Address	Undefined	R/W
01h	11h	Channel 0 DMA Base & Current Count	Undefined	R/W
02h	12h	Channel 1 DMA Base & Current Address	Undefined	R/W
03h	13h	Channel 1 DMA Base & Current Count	Undefined	R/W
04h	14h	Channel 2 DMA Base & Current Address	Undefined	R/W
05h	15h	Channel 2 DMA Base & Current Count	Undefined	R/W
06h	16h	Channel 3 DMA Base & Current Address	Undefined	R/W
07h	17h	Channel 3 DMA Base & Current Count	Undefined	R/W
08h	18h	Channel 0–3 DMA Command	Undefined	WO
		Channel 0–3 DMA Status	Undefined	RO
0Ah	1Ah	Channel 0–3 DMA Write Single Mask	000001XXb	WO
0Bh	1Bh	Channel 0–3 DMA Channel Mode	000000XXb	WO
0Ch	1Ch	Channel 0–3 DMA Clear Byte Pointer	Undefined	WO
0Dh	1Dh	Channel 0–3 DMA Master Clear	Undefined	WO
0Eh	1Eh	Channel 0–3 DMA Clear Mask	Undefined	WO
0Fh	1Fh	Channel 0–3 DMA Write All Mask	0Fh	R/W
80h	90h	Reserved Page	Undefined	R/W
81h	91h	Channel 2 DMA Memory Low Page	Undefined	R/W
82h	—	Channel 3 DMA Memory Low Page	Undefined	R/W
83h	93h	Channel 1 DMA Memory Low Page	Undefined	R/W
84h–86h	94h–96h	Reserved Pages	Undefined	R/W
87h	97h	Channel 0 DMA Memory Low Page	Undefined	R/W
88h	98h	Reserved Page	Undefined	R/W
89h	99h	Channel 6 DMA Memory Low Page	Undefined	R/W
8Ah	9Ah	Channel 7 DMA Memory Low Page	Undefined	R/W
8Bh	9Bh	Channel 5 DMA Memory Low Page	Undefined	R/W
8Ch–8Eh	9Ch–9Eh	Reserved Page	Undefined	R/W
8Fh	9Fh	Refresh Low Page	Undefined	R/W
C0h	C1h	Channel 4 DMA Base & Current Address	Undefined	R/W
C2h	C3h	Channel 4 DMA Base & Current Count	Undefined	R/W
C4h	C5h	Channel 5 DMA Base & Current Address	Undefined	R/W
C6h	C7h	Channel 5 DMA Base & Current Count	Undefined	R/W
C8h	C9h	Channel 6 DMA Base & Current Address	Undefined	R/W
CAh	CBh	Channel 6 DMA Base & Current Count	Undefined	R/W
CCh	CDh	Channel 7 DMA Base & Current Address	Undefined	R/W





Table 106. DMA Registers (Sheet 2 of 2)

Port	Alias	Register Name	Default	Type
CEh	CFh	Channel 7 DMA Base & Current Count	Undefined	R/W
D0h	D1h	Channel 4–7 DMA Command	Undefined	WO
		Channel 4–7 DMA Status	Undefined	RO
D4h	D5h	Channel 4–7 DMA Write Single Mask	000001XXb	WO
D6h	D7h	Channel 4–7 DMA Channel Mode	000000XXb	WO
D8h	D9h	Channel 4–7 DMA Clear Byte Pointer	Undefined	WO
DAh	DBh	Channel 4–7 DMA Master Clear	Undefined	WO
DCh	DDh	Channel 4–7 DMA Clear Mask	Undefined	WO
DEh	DFh	Channel 4–7 DMA Write All Mask	0Fh	R/W

### 9.2.1 DMABASE\_CA—DMA Base and Current Address Registers (LPC I/F—D31:F0)

I/O Address: Ch. #0 = 00h; Ch. #1 = 02h Attribute: R/W  
 Ch. #2 = 04h; Ch. #3 = 06h Size: 16 bit (per channel),  
 Ch. #5 = C4h Ch. #6 = C8h but accessed in two 8-bit  
 Ch. #7 = CCh; quantities  
 Default Value: Undef  
 Lockable: No Power Well: Core

Bit	Description
15:0	<p><b>Base and Current Address</b> — R/W. This register determines the address for the transfers to be performed. The address specified points to two separate registers. On writes, the value is stored in the <i>Base Address</i> register and copied to the <i>Current Address</i> register. On reads, the value is returned from the <i>Current Address</i> register.</p> <p>The address increments/decrements in the Current Address register after each transfer, depending on the mode of the transfer. If the channel is in auto-initialize mode, the Current Address register will be reloaded from the Base Address register after a terminal count is generated.</p> <p>For transfers to/from a 16-bit slave (channel's 5-7), the address is shifted left one bit location. Bit 15 will be shifted into Bit 16.</p> <p>The register is accessed in 8 bit quantities. The byte is pointed to by the current byte pointer flip/flop. Before accessing an address register, the byte pointer flip/flop should be cleared to ensure that the low byte is accessed first</p>



### 9.2.2 DMABASE\_CC—DMA Base and Current Count Registers (LPC I/F—D31:F0)

I/O Address: Ch. #0 = 01h; Ch. #1 = 03h Attribute: R/W  
 Ch. #2 = 05h; Ch. #3 = 07h Size: 16-bit (per channel),  
 Ch. #5 = C6h; Ch. #6 = CAh but accessed in two 8-bit  
 Ch. #7 = CEh; quantities  
 Default Value: Undefined  
 Lockable: No Power Well: Core

Bit	Description
15:0	<p><b>Base and Current Count</b> — R/W. This register determines the number of transfers to be performed. The address specified points to two separate registers. On writes, the value is stored in the <i>Base Count</i> register and copied to the <i>Current Count</i> register. On reads, the value is returned from the <i>Current Count</i> register.</p> <p>The actual number of transfers is one more than the number programmed in the Base Count Register (i.e., programming a count of 4h results in 5 transfers). The count is decrements in the Current Count register after each transfer. When the value in the register rolls from 0 to FFFFh, a terminal count is generated. If the channel is in auto-initialize mode, the Current Count register will be reloaded from the Base Count register after a terminal count is generated.</p> <p>For transfers to/from an 8-bit slave (channels 0–3), the count register indicates the number of bytes to be transferred. For transfers to/from a 16-bit slave (channels 5–7), the count register indicates the number of words to be transferred.</p> <p>The register is accessed in 8 bit quantities. The byte is pointed to by the current byte pointer flip/flop. Before accessing a count register, the byte pointer flip/flop should be cleared to ensure that the low byte is accessed first.</p>

### 9.2.3 DMAMEM\_LP—DMA Memory Low Page Registers (LPC I/F—D31:F0)

I/O Address: Ch. #0 = 87h; Ch. #1 = 83h  
 Ch. #2 = 81h; Ch. #3 = 82h  
 Ch. #5 = 8Bh; Ch. #6 = 89h  
 Ch. #7 = 8Ah; Attribute: R/W  
 Default Value: Undefined Size: 8-bit  
 Lockable: No Power Well: Core

Bit	Description
7:0	<p><b>DMA Low Page</b> (ISA Address bits [23:16]) — R/W. This register works in conjunction with the DMA controller's Current Address Register to define the complete 24-bit address for the DMA channel. This register remains static throughout the DMA transfer. Bit 16 of this register is ignored when in 16 bit I/O count by words mode as it is replaced by the bit 15 shifted out from the current address register.</p>



## 9.2.4 DMACMD—DMA Command Register (LPC I/F—D31:F0)

I/O Address: Ch. #0–3 = 08h;  
 Ch. #4–7 = D0h  
 Attribute: WO  
 Default Value: Undefined  
 Size: 8-bit  
 Lockable: No  
 Power Well: Core

Bit	Description
7:5	Reserved. Must be 0.
4	<b>DMA Group Arbitration Priority</b> — WO. Each channel group is individually assigned either fixed or rotating arbitration priority. At part reset, each group is initialized in fixed priority. 0 = Fixed priority to the channel group 1 = Rotating priority to the group.
3	Reserved. Must be 0.
2	<b>DMA Channel Group Enable</b> — WO. Both channel groups are enabled following part reset. 0 = Enable the DMA channel group. 1 = Disable. Disabling channel group 4–7 also disables channel group 0–3, which is cascaded through channel 4.
1:0	Reserved. Must be 0.

## 9.2.5 DMASTA—DMA Status Register (LPC I/F—D31:F0)

I/O Address: Ch. #0–3 = 08h;  
 Ch. #4–7 = D0h  
 Attribute: RO  
 Default Value: Undefined  
 Size: 8-bit  
 Lockable: No  
 Power Well: Core

Bit	Description
7:4	<b>Channel Request Status</b> — RO. When a valid DMA request is pending for a channel, the corresponding bit is set to 1. When a DMA request is not pending for a particular channel, the corresponding bit is set to 0. The source of the DREQ may be hardware or a software request. Note that channel 4 is the cascade channel, so the request status of channel 4 is a logical OR of the request status for channels 0 through 3. 4 = Channel 0 5 = Channel 1 (5) 6 = Channel 2 (6) 7 = Channel 3 (7)
3:0	<b>Channel Terminal Count Status</b> — RO. When a channel reaches terminal count (TC), its status bit is set to 1. If TC has not been reached, the status bit is set to 0. Channel 4 is programmed for cascade, so the TC bit response for channel 4 is irrelevant: 0 = Channel 0 1 = Channel 1 (5) 2 = Channel 2 (6) 3 = Channel 3 (7)



### 9.2.6 DMA\_WRSMSK—DMA Write Single Mask Register (LPC I/F—D31:F0)

I/O Address: Ch. #0–3 = 0Ah;  
Ch. #4–7 = D4h  
Default Value: 0000 01xx  
Lockable: No

Attribute: WO  
Size: 8-bit  
Power Well: Core

Bit	Description
7:3	Reserved. Must be 0.
2	<b>Channel Mask Select</b> — WO. 0 = Enable DREQ for the selected channel. The channel is selected through bits [1:0]. Therefore, only one channel can be masked / unmasked at a time. 1 = Disable DREQ for the selected channel.
1:0	<b>DMA Channel Select</b> — WO. These bits select the DMA Channel Mode Register to program. 00 = Channel 0 (4) 01 = Channel 1 (5) 10 = Channel 2 (6) 11 = Channel 3 (7)



## 9.2.7 DMACH\_MODE—DMA Channel Mode Register (LPC I/F—D31:F0)

I/O Address: Ch. #0–3 = 0Bh;  
 Ch. #4–7 = D6h  
 Attribute: WO  
 Default Value: 0000 00xx  
 Size: 8-bit  
 Lockable: No  
 Power Well: Core

Bit	Description
7:6	<b>DMA Transfer Mode</b> — WO. Each DMA channel can be programmed in one of four different modes: 00 = Demand mode 01 = Single mode 10 = Reserved 11 = Cascade mode
5	<b>Address Increment/Decrement Select</b> — WO. This bit controls address increment/decrement during DMA transfers. 0 = Address increment. (default after part reset or Master Clear) 1 = Address decrement.
4	<b>Autoinitialize Enable</b> — WO. 0 = Autoinitialize feature is disabled and DMA transfers terminate on a terminal count. A part reset or Master Clear disables autoinitialization. 1 = DMA restores the Base Address and Count registers to the current registers following a terminal count (TC).
3:2	<b>DMA Transfer Type</b> — WO. These bits represent the direction of the DMA transfer. When the channel is programmed for cascade mode, (bits[7:6] = 11) the transfer type is irrelevant. 00 = Verify – No I/O or memory strobes generated 01 = Write – Data transferred from the I/O devices to memory 10 = Read – Data transferred from memory to the I/O device 11 = Invalid
1:0	<b>DMA Channel Select</b> — WO. These bits select the DMA Channel Mode Register that will be written by bits [7:2]. 00 = Channel 0 (4) 01 = Channel 1 (5) 10 = Channel 2 (6) 11 = Channel 3 (7)



### 9.2.8 DMA Clear Byte Pointer Register (LPC I/F—D31:F0)

I/O Address: Ch. #0–3 = 0Ch;  
Ch. #4–7 = D8h  
Default Value: xxxx xxxx  
Lockable: No

Attribute: WO  
Size: 8-bit  
Power Well: Core

Bit	Description
7:0	<b>Clear Byte Pointer</b> — WO. No specific pattern. Command enabled with a write to the I/O port address. Writing to this register initializes the byte pointer flip/flop to a known state. It clears the internal latch used to address the upper or lower byte of the 16-bit Address and Word Count Registers. The latch is also cleared by part reset and by the Master Clear command. This command precedes the first access to a 16-bit DMA controller register. The first access to a 16-bit register will then access the significant byte, and the second access automatically accesses the most significant byte.

### 9.2.9 DMA Master Clear Register (LPC I/F—D31:F0)

I/O Address: Ch. #0–3 = 0Dh;  
Ch. #4–7 = DAh  
Default Value: xxxx xxxx

Attribute: WO  
Size: 8-bit

Bit	Description
7:0	<b>Master Clear</b> — WO. No specific pattern. Enabled with a write to the port. This has the same effect as the hardware Reset. The Command, Status, Request, and Byte Pointer flip/flop registers are cleared and the Mask Register is set.



### 9.2.10 DMA\_CLMSK—DMA Clear Mask Register (LPC I/F—D31:F0)

I/O Address: Ch. #0–3 = 0Eh;  
 Ch. #4–7 = DCh  
 Attribute: WO  
 Default Value: xxxx xxxx  
 Size: 8-bit  
 Lockable: No  
 Power Well: Core

Bit	Description
7:0	<b>Clear Mask Register</b> — WO. No specific pattern. Command enabled with a write to the port.

### 9.2.11 DMA\_WRMSK—DMA Write All Mask Register (LPC I/F—D31:F0)

I/O Address: Ch. #0–3 = 0Fh;  
 Ch. #4–7 = DEh  
 Attribute: R/W  
 Default Value: 0000 1111  
 Size: 8-bit  
 Lockable: No  
 Power Well: Core

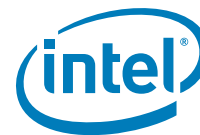
Bit	Description
7:4	Reserved. Must be 0.
3:0	<p><b>Channel Mask Bits</b> — R/W. This register permits all four channels to be simultaneously enabled/disabled instead of enabling/disabling each channel individually, as is the case with the Mask Register – Write Single Mask Bit. In addition, this register has a read path to allow the status of the channel mask bits to be read. A channel's mask bit is automatically set to 1 when the Current Byte/Word Count Register reaches terminal count (unless the channel is in auto-initialization mode).</p> <p>Setting the bit(s) to a 1 disables the corresponding DREQ(s). Setting the bit(s) to a 0 enables the corresponding DREQ(s). Bits [3:0] are set to 1 upon part reset or Master Clear. When read, bits [3:0] indicate the DMA channel [3:0] ([7:4]) mask status.</p> <p>Bit 0 = Channel 0 (4)    1 = Masked, 0 = Not Masked            Bit 1 = Channel 1 (5)    1 = Masked, 0 = Not Masked            Bit 2 = Channel 2 (6)    1 = Masked, 0 = Not Masked            Bit 3 = Channel 3 (7)    1 = Masked, 0 = Not Masked</p> <p><b>NOTE:</b> Disabling channel 4 also disables channels 0–3 due to the cascade of channel's 0 – 3 through channel 4.</p>



### 9.3 Timer I/O Registers (LPC I/F—D31:F0)

Port	Aliases	Register Name	Default Value	Type
40h	50h	Counter 0 Interval Time Status Byte Format	0XXXXXXXXb	RO
		Counter 0 Counter Access Port	Undefined	R/W
41h	51h	Counter 1 Interval Time Status Byte Format	0XXXXXXXXb	RO
		Counter 1 Counter Access Port	Undefined	R/W
42h	52h	Counter 2 Interval Time Status Byte Format	0XXXXXXXXb	RO
		Counter 2 Counter Access Port	Undefined	R/W
43h	53h	Timer Control Word	Undefined	WO
		Timer Control Word Register	XXXXXXXX0b	WO
		Counter Latch Command	X0h	WO





### 9.3.1 TCW—Timer Control Word Register (LPC I/F—D31:F0)

I/O Address: 43h                                      Attribute: WO  
 Default Value: All bits undefined                      Size: 8 bits

This register is programmed prior to any counter being accessed to specify counter modes. Following component reset, the control words for each register are undefined and each counter output is 0. Each timer must be programmed to bring it into a known state.

Bit	Description														
7:6	<p><b>Counter Select</b> — WO. The Counter Selection bits select the counter the control word acts upon as shown below. The Read Back Command is selected when bits[7:6] are both 1.</p> <p>00 = Counter 0 select            01 = Counter 1 select            10 = Counter 2 select            11 = Read Back Command</p>														
5:4	<p><b>Read/Write Select</b> — WO. These bits are the read/write control bits. The actual counter programming is done through the counter port (40h for counter 0, 41h for counter 1, and 42h for counter 2).</p> <p>00 = Counter Latch Command            01 = Read/Write Least Significant Byte (LSB)            10 = Read/Write Most Significant Byte (MSB)            11 = Read/Write LSB then MSB</p>														
3:1	<p><b>Counter Mode Selection</b> — WO. These bits select one of six possible modes of operation for the selected counter.</p> <table border="0"> <thead> <tr> <th>Bit Value</th> <th>Mode</th> </tr> </thead> <tbody> <tr> <td>000b</td> <td>Mode 0 Out signal on end of count (=0)</td> </tr> <tr> <td>001b</td> <td>Mode 1 Hardware retriggerable one-shot</td> </tr> <tr> <td>x10b</td> <td>Mode 2 Rate generator (divide by n counter)</td> </tr> <tr> <td>x11b</td> <td>Mode 3 Square wave output</td> </tr> <tr> <td>100b</td> <td>Mode 4 Software triggered strobe</td> </tr> <tr> <td>101b</td> <td>Mode 5 Hardware triggered strobe</td> </tr> </tbody> </table>	Bit Value	Mode	000b	Mode 0 Out signal on end of count (=0)	001b	Mode 1 Hardware retriggerable one-shot	x10b	Mode 2 Rate generator (divide by n counter)	x11b	Mode 3 Square wave output	100b	Mode 4 Software triggered strobe	101b	Mode 5 Hardware triggered strobe
Bit Value	Mode														
000b	Mode 0 Out signal on end of count (=0)														
001b	Mode 1 Hardware retriggerable one-shot														
x10b	Mode 2 Rate generator (divide by n counter)														
x11b	Mode 3 Square wave output														
100b	Mode 4 Software triggered strobe														
101b	Mode 5 Hardware triggered strobe														
0	<p><b>Binary/BCD Countdown Select</b> — WO.</p> <p>0 = Binary countdown is used. The largest possible binary count is <math>2^{16}</math>            1 = Binary coded decimal (BCD) count is used. The largest possible BCD count is <math>10^4</math></p>														

There are two special commands that can be issued to the counters through this register, the Read Back Command and the Counter Latch Command. When these commands are chosen, several bits within this register are redefined. These register formats are described in the following sub-sections:

#### RDBK\_CMD—Read Back Command (LPC I/F—D31:F0)

The Read Back Command is used to determine the count value, programmed mode, and current states of the OUT pin and Null count flag of the selected counter or counters. Status and/or count may be latched in any or all of the counters by selecting the counter during the register write. The count and status remain latched until read, and further latch commands are ignored until the count is read. Both count and status of the selected counters may be latched simultaneously by setting both bit 5 and bit 4



to 0. If both are latched, the first read operation from that counter returns the latched status. The next one or two reads, depending on whether the counter is programmed for one or two byte counts, returns the latched count. Subsequent reads return an unlatched count.

Bit	Description
7:6	<b>Read Back Command.</b> Must be 11 to select the Read Back Command
5	<b>Latch Count of Selected Counters.</b> 0 = Current count value of the selected counters will be latched 1 = Current count will not be latched
4	<b>Latch Status of Selected Counters.</b> 0 = Status of the selected counters will be latched 1 = Status will not be latched
3	<b>Counter 2 Select.</b> 1 = Counter 2 count and/or status will be latched
2	<b>Counter 1 Select.</b> 1 = Counter 1 count and/or status will be latched
1	<b>Counter 0 Select.</b> 1 = Counter 0 count and/or status will be latched.
0	Reserved. Must be 0.

#### LTCH\_CMD—Counter Latch Command (LPC I/F—D31:F0)

The Counter Latch Command latches the current count value. This command is used to ensure that the count read from the counter is accurate. The count value is then read from each counter's count register through the Counter Ports Access Ports Register (40h for counter 0, 41h for counter 1, and 42h for counter 2). The count must be read according to the programmed format, i.e., if the counter is programmed for two byte counts, two bytes must be read. The two bytes do not have to be read one right after the other (read, write, or programming operations for other counters may be inserted between the reads). If a counter is latched once and then latched again before the count is read, the second Counter Latch Command is ignored.

Bit	Description
7:6	<b>Counter Selection.</b> These bits select the counter for latching. If "11" is written, then the write is interpreted as a read back command. 00 = Counter 0 01 = Counter 1 10 = Counter 2
5:4	<b>Counter Latch Command.</b> 00 = Selects the Counter Latch Command.
3:0	Reserved. Must be 0.



### 9.3.2 SBYTE\_FMT—Interval Timer Status Byte Format Register (LPC I/F—D31:F0)

I/O Address: Counter 0 = 40h,  
 Counter 1 = 41h, Attribute: RO  
 Counter 2 = 42h Size: 8 bits per counter  
 Default Value: Bits[6:0] undefined, Bit 7=0

Each counter's status byte can be read following a Read Back Command. If latch status is chosen (bit 4=0, Read Back Command) as a read back option for a given counter, the next read from the counter's Counter Access Ports Register (40h for counter 0, 41h for counter 1, and 42h for counter 2) returns the status byte. The status byte returns the following:

Bit	Description
7	<b>Counter OUT Pin State</b> — RO. 0 = OUT pin of the counter is also a 0 1 = OUT pin of the counter is also a 1
6	<b>Count Register Status</b> — RO. This bit indicates when the last count written to the Count Register (CR) has been loaded into the counting element (CE). The exact time this happens depends on the counter mode, but until the count is loaded into the counting element (CE), the count value will be incorrect. 0 = Count has been transferred from CR to CE and is available for reading. 1 = Null Count. Count has not been transferred from CR to CE and is not yet available for reading.
5:4	<b>Read/Write Selection Status</b> — RO. These reflect the read/write selection made through bits[5:4] of the control register. The binary codes returned during the status read match the codes used to program the counter read/write selection. 00 = Counter Latch Command 01 = Read/Write Least Significant Byte (LSB) 10 = Read/Write Most Significant Byte (MSB) 11 = Read/Write LSB then MSB
3:1	<b>Mode Selection Status</b> — RO. These bits return the counter mode programming. The binary code returned matches the code used to program the counter mode, as listed under the bit function above. 000 = Mode 0 — Out signal on end of count (=0) 001 = Mode 1 — Hardware retriggerable one-shot x10 = Mode 2 — Rate generator (divide by n counter) x11 = Mode 3 — Square wave output 100 = Mode 4 — Software triggered strobe 101 = Mode 5 — Hardware triggered strobe
0	<b>Countdown Type Status</b> — RO. This bit reflects the current countdown type. 0 = Binary countdown 1 = Binary Coded Decimal (BCD) countdown.



### 9.3.3 Counter Access Ports Register (LPC I/F—D31:F0)

I/O Address: Counter 0 – 40h,  
 Counter 1 – 41h, Attribute: R/W  
 Counter 2 – 42h  
 Default Value: All bits undefined Size: 8 bit

Bit	Description
7:0	<b>Counter Port</b> — R/W. Each counter port address is used to program the 16-bit Count Register. The order of programming, either LSB only, MSB only, or LSB then MSB, is defined with the Interval Counter Control Register at port 43h. The counter port is also used to read the current count from the Count Register, and return the status of the counter programming following a Read Back Command.

## 9.4 8259 Interrupt Controller (PIC) Registers (LPC I/F—D31:F0)

### 9.4.1 Interrupt Controller I/O MAP (LPC I/F—D31:F0)

The interrupt controller registers are located at 20h and 21h for the master controller (IRQ 0–7), and at A0h and A1h for the slave controller (IRQ 8–13). These registers have multiple functions, depending upon the data written to them. Table 107 shows the different register possibilities for each address.

Table 107. PIC Registers (LPC I/F—D31:F0)

Port	Aliases	Register Name	Default Value	Type
20h	24h, 28h, 2Ch, 30h, 34h, 38h, 3Ch	Master PIC ICW1 Init. Cmd Word 1	Undefined	WO
		Master PIC OCW2 Op Ctrl Word 2	001XXXXXb	WO
		Master PIC OCW3 Op Ctrl Word 3	X01XXX10b	WO
21h	25h, 29h, 2Dh, 31h, 35h, 39h, 3Dh	Master PIC ICW2 Init. Cmd Word 2	Undefined	WO
		Master PIC ICW3 Init. Cmd Word 3	Undefined	WO
		Master PIC ICW4 Init. Cmd Word 4	01h	WO
		Master PIC OCW1 Op Ctrl Word 1	00h	R/W
A0h	A4h, A8h, ACh, B0h, B4h, B8h, BCh	Slave PIC ICW1 Init. Cmd Word 1	Undefined	WO
		Slave PIC OCW2 Op Ctrl Word 2	001XXXXXb	WO
		Slave PIC OCW3 Op Ctrl Word 3	X01XXX10b	WO
A1h	A5h, A9h, ADh, B1h, B5h, B9h, BDh	Slave PIC ICW2 Init. Cmd Word 2	Undefined	WO
		Slave PIC ICW3 Init. Cmd Word 3	Undefined	WO
		Slave PIC ICW4 Init. Cmd Word 4	01h	WO
		Slave PIC OCW1 Op Ctrl Word 1	00h	R/W
4D0h	–	Master PIC Edge/Level Triggered	00h	R/W
4D1h	–	Slave PIC Edge/Level Triggered	00h	R/W

**Note:** Refer to note addressing active-low interrupt sources in 8259 Interrupt Controllers section (Chapter 5.8).



## 9.4.2 ICW1—Initialization Command Word 1 Register (LPC I/F—D31:F0)

Offset Address: Master Controller – 20h      Attribute:      WO  
 Slave Controller – A0h      Size:      8 bit /controller  
 Default Value: All bits undefined

A write to Initialization Command Word 1 starts the interrupt controller initialization sequence, during which the following occurs:

1. The Interrupt Mask register is cleared.
2. IRQ7 input is assigned priority 7.
3. The slave mode address is set to 7.
4. Special mask mode is cleared and Status Read is set to IRR.

Once this write occurs, the controller expects writes to ICW2, ICW3, and ICW4 to complete the initialization sequence.

Bit	Description
7:5	<b>ICW/OCW Select</b> — WO. These bits are MCS-85 specific, and not needed. 000 = Should be programmed to “000”
4	<b>ICW/OCW Select</b> — WO. 1 = This bit must be a 1 to select ICW1 and enable the ICW2, ICW3, and ICW4 sequence.
3	<b>Edge/Level Bank Select (LTIM)</b> — WO. Disabled. Replaced by the edge/level triggered control registers (ELCR, D31:F0:4D0h, D31:F0:4D1h).
2	<b>ADI</b> — WO. 0 = Ignored for the ICH8. Should be programmed to 0.
1	<b>Single or Cascade (SNGL)</b> — WO. 0 = Must be programmed to a 0 to indicate two controllers operating in cascade mode.
0	<b>ICW4 Write Required (IC4)</b> — WO. 1 = This bit must be programmed to a 1 to indicate that ICW4 needs to be programmed.



### 9.4.3 ICW2—Initialization Command Word 2 Register (LPC I/F—D31:F0)

Offset Address: Master Controller – 21h      Attribute: WO  
 Slave Controller – A1h      Size: 8 bit /controller  
 Default Value: All bits undefined

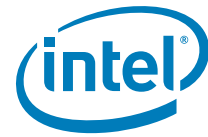
ICW2 is used to initialize the interrupt controller with the five most significant bits of the interrupt vector address. The value programmed for bits[7:3] is used by the processor to define the base address in the interrupt vector table for the interrupt routines associated with each IRQ on the controller. Typical ISA ICW2 values are 08h for the master controller and 70h for the slave controller.

Bit	Description																											
7:3	<b>Interrupt Vector Base Address</b> — WO. Bits [7:3] define the base address in the interrupt vector table for the interrupt routines associated with each interrupt request level input.																											
2:0	<p><b>Interrupt Request Level</b> — WO. When writing ICW2, these bits should all be 0. During an interrupt acknowledge cycle, these bits are programmed by the interrupt controller with the interrupt to be serviced. This is combined with bits [7:3] to form the interrupt vector driven onto the data bus during the second INTA# cycle. The code is a three bit binary code:</p> <table border="1"> <thead> <tr> <th>Code</th> <th>Master Interrupt</th> <th>Slave Interrupt</th> </tr> </thead> <tbody> <tr> <td>000b</td> <td>IRQ0</td> <td>IRQ8</td> </tr> <tr> <td>001b</td> <td>IRQ1</td> <td>IRQ9</td> </tr> <tr> <td>010b</td> <td>IRQ2</td> <td>IRQ10</td> </tr> <tr> <td>011b</td> <td>IRQ3</td> <td>IRQ11</td> </tr> <tr> <td>100b</td> <td>IRQ4</td> <td>IRQ12</td> </tr> <tr> <td>101b</td> <td>IRQ5</td> <td>IRQ13</td> </tr> <tr> <td>110b</td> <td>IRQ6</td> <td>IRQ14</td> </tr> <tr> <td>111b</td> <td>IRQ7</td> <td>IRQ15</td> </tr> </tbody> </table>	Code	Master Interrupt	Slave Interrupt	000b	IRQ0	IRQ8	001b	IRQ1	IRQ9	010b	IRQ2	IRQ10	011b	IRQ3	IRQ11	100b	IRQ4	IRQ12	101b	IRQ5	IRQ13	110b	IRQ6	IRQ14	111b	IRQ7	IRQ15
Code	Master Interrupt	Slave Interrupt																										
000b	IRQ0	IRQ8																										
001b	IRQ1	IRQ9																										
010b	IRQ2	IRQ10																										
011b	IRQ3	IRQ11																										
100b	IRQ4	IRQ12																										
101b	IRQ5	IRQ13																										
110b	IRQ6	IRQ14																										
111b	IRQ7	IRQ15																										

### 9.4.4 ICW3—Master Controller Initialization Command Word 3 Register (LPC I/F—D31:F0)

Offset Address: 21h      Attribute: WO  
 Default Value: All bits undefined      Size: 8 bits

Bit	Description
7:3	0 = These bits must be programmed to 0.
2	<p><b>Cascaded Interrupt Controller IRQ Connection</b> — WO. This bit indicates that the slave controller is cascaded on IRQ2. When IRQ8#–IRQ15 is asserted, it goes through the slave controller’s priority resolver. The slave controller’s INTR output onto IRQ2. IRQ2 then goes through the master controller’s priority solver. If it wins, the INTR signal is asserted to the processor, and the returning interrupt acknowledge returns the interrupt vector for the slave controller.</p> <p>1 = This bit must always be programmed to a 1.</p>
1:0	0 = These bits must be programmed to 0.



### 9.4.5 ICW3—Slave Controller Initialization Command Word 3 Register (LPC I/F—D31:F0)

Offset Address: A1h Attribute: WO  
 Default Value: All bits undefined Size: 8 bits

Bit	Description
7:3	0 = These bits must be programmed to 0.
2:0	<b>Slave Identification Code</b> — WO. These bits are compared against the slave identification code broadcast by the master controller from the trailing edge of the first internal INTA# pulse to the trailing edge of the second internal INTA# pulse. These bits must be programmed to 02h to match the code broadcast by the master controller. When 02h is broadcast by the master controller during the INTA# sequence, the slave controller assumes responsibility for broadcasting the interrupt vector.

### 9.4.6 ICW4—Initialization Command Word 4 Register (LPC I/F—D31:F0)

Offset Address: Master Controller – 021h Attribute: WO  
 Slave Controller – 0A1h Size: 8 bits  
 Default Value: 01h

Bit	Description
7:5	0 = These bits must be programmed to 0.
4	<b>Special Fully Nested Mode (SFNM)</b> — WO. 0 = Should normally be disabled by writing a 0 to this bit. 1 = Special fully nested mode is programmed.
3	<b>Buffered Mode (BUF)</b> — WO. 0 = Must be programmed to 0 for the ICH8. This is non-buffered mode.
2	<b>Master/Slave in Buffered Mode</b> — WO. Not used. 0 = Should always be programmed to 0.
1	<b>Automatic End of Interrupt (AEOI)</b> — WO. 0 = This bit should normally be programmed to 0. This is the normal end of interrupt. 1 = Automatic End of Interrupt (AEOI) mode is programmed.
0	<b>Microprocessor Mode</b> — WO. 1 = Must be programmed to 1 to indicate that the controller is operating in an Intel Architecture-based system.



### 9.4.7 OCW1—Operational Control Word 1 (Interrupt Mask) Register (LPC I/F—D31:F0)

Offset Address: Master Controller – 021h    Attribute: R/W  
 Slave Controller – 0A1h    Size: 8 bits  
 Default Value: 00h

Bit	Description
7:0	<b>Interrupt Request Mask</b> — R/W. When a 1 is written to any bit in this register, the corresponding IRQ line is masked. When a 0 is written to any bit in this register, the corresponding IRQ mask bit is cleared, and interrupt requests will again be accepted by the controller. Masking IRQ2 on the master controller will also mask the interrupt requests from the slave controller.

### 9.4.8 OCW2—Operational Control Word 2 Register (LPC I/F—D31:F0)

Offset Address: Master Controller – 020h    Attribute: WO  
 Slave Controller – 0A0h    Size: 8 bits  
 Default Value: Bit[4:0]=undefined, Bit[7:5]=001

Following a part reset or ICW initialization, the controller enters the fully nested mode of operation. Non-specific EOI without rotation is the default. Both rotation mode and specific EOI mode are disabled following initialization.

Bit	Description																				
7:5	<b>Rotate and EOI Codes</b> (R, SL, EOI) — WO. These three bits control the Rotate and End of Interrupt modes and combinations of the two. 000 = Rotate in Auto EOI Mode (Clear) 001 = Non-specific EOI command 010 = No Operation 011 = *Specific EOI Command 100 = Rotate in Auto EOI Mode (Set) 101 = Rotate on Non-Specific EOI Command 110 = *Set Priority Command 111 = *Rotate on Specific EOI Command *L0 – L2 Are Used																				
4:3	<b>OCW2 Select</b> — WO. When selecting OCW2, bits 4:3 = "00"																				
2:0	<b>Interrupt Level Select</b> (L2, L1, L0) — WO. L2, L1, and L0 determine the interrupt level acted upon when the SL bit is active. A simple binary code, outlined below, selects the channel for the command to act upon. When the SL bit is inactive, these bits do not have a defined function; programming L2, L1 and L0 to 0 is sufficient in this case.																				
	<table border="0"> <thead> <tr> <th>Code</th> <th>Interrupt Level</th> <th>Code</th> <th>Interrupt Level</th> </tr> </thead> <tbody> <tr> <td>000b</td> <td>IRQ0/8</td> <td>000b</td> <td>IRQ4/12</td> </tr> <tr> <td>001b</td> <td>IRQ1/9</td> <td>001b</td> <td>IRQ5/13</td> </tr> <tr> <td>010b</td> <td>IRQ2/10</td> <td>010b</td> <td>IRQ6/14</td> </tr> <tr> <td>011b</td> <td>IRQ3/11</td> <td>011b</td> <td>IRQ7/15</td> </tr> </tbody> </table>	Code	Interrupt Level	Code	Interrupt Level	000b	IRQ0/8	000b	IRQ4/12	001b	IRQ1/9	001b	IRQ5/13	010b	IRQ2/10	010b	IRQ6/14	011b	IRQ3/11	011b	IRQ7/15
Code	Interrupt Level	Code	Interrupt Level																		
000b	IRQ0/8	000b	IRQ4/12																		
001b	IRQ1/9	001b	IRQ5/13																		
010b	IRQ2/10	010b	IRQ6/14																		
011b	IRQ3/11	011b	IRQ7/15																		





### 9.4.9 OCW3—Operational Control Word 3 Register (LPC I/F—D31:F0)

Offset Address: Master Controller – 020h    Attribute:            WO  
 Slave Controller – 0A0h    Size:                8 bits  
 Default Value: Bit[6,0]=0, Bit[7,4:2]=undefined,  
 Bit[5,1]=1

Bit	Description
7	Reserved. Must be 0.
6	<b>Special Mask Mode (SMM)</b> — WO. 1 = The Special Mask Mode can be used by an interrupt service routine to dynamically alter the system priority structure while the routine is executing, through selective enabling/disabling of the other channel's mask bits. Bit 5, the ESMM bit, must be set for this bit to have any meaning.
5	<b>Enable Special Mask Mode (ESMM)</b> — WO. 0 = Disable. The SMM bit becomes a "don't care". 1 = Enable the SMM bit to set or reset the Special Mask Mode.
4:3	<b>OCW3 Select</b> — WO. When selecting OCW3, bits 4:3 = 01
2	<b>Poll Mode Command</b> — WO. 0 = Disable. Poll Command is not issued. 1 = Enable. The next I/O read to the interrupt controller is treated as an interrupt acknowledge cycle. An encoded byte is driven onto the data bus, representing the highest priority level requesting service.
1:0	<b>Register Read Command</b> — WO. These bits provide control for reading the In-Service Register (ISR) and the Interrupt Request Register (IRR). When bit 1=0, bit 0 will not affect the register read selection. When bit 1=1, bit 0 selects the register status returned following an OCW3 read. If bit 0=0, the IRR will be read. If bit 0=1, the ISR will be read. Following ICW initialization, the default OCW3 port address read will be "read IRR". To retain the current selection (read ISR or read IRR), always write a 0 to bit 1 when programming this register. The selected register can be read repeatedly without reprogramming OCW3. To select a new status register, OCW3 must be reprogrammed prior to attempting the read. 00 = No Action 01 = No Action 10 = Read IRQ Register 11 = Read IS Register



### 9.4.10 ELCR1—Master Controller Edge/Level Triggered Register (LPC I/F—D31:F0)

Offset Address: 4D0h  
Default Value: 00h

Attribute: R/W  
Size: 8 bits

In edge mode, (bit[x] = 0), the interrupt is recognized by a low to high transition. In level mode (bit[x] = 1), the interrupt is recognized by a high level. The cascade channel, IRQ2, the heart beat timer (IRQ0), and the keyboard controller (IRQ1), cannot be put into level mode.

Bit	Description
7	<b>IRQ7 ECL</b> — R/W. 0 = Edge. 1 = Level.
6	<b>IRQ6 ECL</b> — R/W. 0 = Edge. 1 = Level.
5	<b>IRQ5 ECL</b> — R/W. 0 = Edge. 1 = Level.
4	<b>IRQ4 ECL</b> — R/W. 0 = Edge. 1 = Level.
3	<b>IRQ3 ECL</b> — R/W. 0 = Edge. 1 = Level.
2:0	Reserved. Must be 0.



### 9.4.11 ELCR2—Slave Controller Edge/Level Triggered Register (LPC I/F—D31:F0)

Offset Address: 4D1h  
Default Value: 00h

Attribute: R/W  
Size: 8 bits

In edge mode, (bit[x] = 0), the interrupt is recognized by a low to high transition. In level mode (bit[x] = 1), the interrupt is recognized by a high level. The real time clock, IRQ8#, and the floating point error interrupt, IRQ13, cannot be programmed for level mode.

Bit	Description
7	<b>IRQ15 ECL</b> — R/W. 0 = Edge 1 = Level
6	<b>IRQ14 ECL</b> — R/W. 0 = Edge 1 = Level
5	Reserved. Must be 0.
4	<b>IRQ12 ECL</b> — R/W. 0 = Edge 1 = Level
3	<b>IRQ11 ECL</b> — R/W. 0 = Edge 1 = Level
2	<b>IRQ10 ECL</b> — R/W. 0 = Edge 1 = Level
1	<b>IRQ9 ECL</b> — R/W. 0 = Edge 1 = Level
0	Reserved. Must be 0.



## 9.5 Advanced Programmable Interrupt Controller (APIC) (D31:F0)

### 9.5.1 APIC Register Map (LPC I/F—D31:F0)

The APIC is accessed via an indirect addressing scheme. Two registers are visible by software for manipulation of most of the APIC registers. These registers are mapped into memory space. The address bits 15:12 of the address range are programmable through bit 7:4 of OIC register (Chipset Configuration Register, offset 31FFh.) The registers are shown in [Table 108](#).

**Table 108. APIC Direct Registers (LPC I/F—D31:F0)**

Address	Mnemonic	Register Name	Size	Type
FECO_0000h	IND	Index	8 bits	R/W
FECO_0010h	DAT	Data	32 bits	R/W
FECO_0040h	EOIR	EOI	32 bits	WO

[Table 109](#) lists the registers which can be accessed within the APIC via the Index Register. When accessing these registers, accesses must be done one dword at a time. For example, software should never access byte 2 from the Data register before accessing bytes 0 and 1. The hardware will not attempt to recover from a bad programming model in this case.

**Table 109. APIC Indirect Registers (LPC I/F—D31:F0)**

Index	Mnemonic	Register Name	Size	Type
00	ID	Identification	32 bits	R/W
01	VER	Version	32 bits	RO
02–0F	—	Reserved	—	RO
10–11	REDIR_TBLO	Redirection Table 0	64 bits	R/W, RO
12–13	REDIR_TBL1	Redirection Table 1	64 bits	R/W, RO
...	...	...	...	...
3E–3F	REDIR_TBL23	Redirection Table 23	64 bits	R/W, RO
40–FF	—	Reserved	—	RO

### 9.5.2 IND—Index Register (LPC I/F—D31:F0)

Memory Address FECO\_0000h

Attribute:

R/W

Default Value: 00h

Size:

8 bits

The Index Register will select which APIC indirect register to be manipulated by software. The selector values for the indirect registers are listed in [Table 109](#). Software will program this register to select the desired APIC internal register

Bit	Description
7:0	<b>APIC Index</b> — R/W. This is an 8-bit pointer into the I/O APIC register table.



### 9.5.3 DAT—Data Register (LPC I/F—D31:F0)

Memory Address FEC0\_0010h                      Attribute:              R/W  
 Default Value:    00000000h                      Size:                    32 bits

This is a 32-bit register specifying the data to be read or written to the register pointed to by the Index register. This register can only be accessed in dword quantities.

Bit	Description
7:0	<b>APIC Data</b> — R/W. This is a 32-bit register for the data to be read or written to the APIC indirect register (Figure 109) pointed to by the Index register (Memory Address FEC0_0000h).

### 9.5.4 EOIR—EOI Register (LPC I/F—D31:F0)

Memory Address FEC0h\_0040h                      Attribute:              WO  
 Default Value:    N/A    Size:                    32 bits

The EOI register is present to provide a mechanism to maintain the level triggered semantics for level-triggered interrupts issued on the parallel bus.

When a write is issued to this register, the I/O APIC will check the lower 8 bits written to this register, and compare it with the vector field for each entry in the I/O Redirection Table. When a match is found, the Remote\_IRR bit (Index Offset 10h, bit 14) for that I/O Redirection Entry will be cleared.

**Note:** If multiple I/O Redirection entries, for any reason, assign the same vector for more than one interrupt input, each of those entries will have the Remote\_IRR bit reset to 0. The interrupt which was prematurely reset will not be lost because if its input remained active when the Remote\_IRR bit is cleared, the interrupt will be reissued and serviced at a later time. Note: Only bits 7:0 are actually used. Bits 31:8 are ignored by the ICH8.

**Note:** To provide for future expansion, the processor should always write a value of 0 to bits 31:8.

Bit	Description
31:8	Reserved. To provide for future expansion, the processor should always write a value of 0 to Bits 31:8.
7:0	<b>Redirection Entry Clear</b> — WO. When a write is issued to this register, the I/O APIC will check this field, and compare it with the vector field for each entry in the I/O Redirection Table. When a match is found, the Remote_IRR bit for that I/O Redirection Entry will be cleared.



### 9.5.5 ID—Identification Register (LPC I/F—D31:F0)

Index Offset: 00h                                      Attribute: R/W  
 Default Value: 00000000h                          Size: 32 bits

The APIC ID serves as a physical name of the APIC. The APIC bus arbitration ID for the APIC is derived from its I/O APIC ID. This register is reset to 0 on power-up reset.

Bit	Description
31:28	Reserved
27:24	<b>APIC ID</b> — R/W. Software must program this value before using the APIC.
23:16	Reserved
15	Scratchpad Bit.
14:0	Reserved

### 9.5.6 VER—Version Register (LPC I/F—D31:F0)

Index Offset: 01h                                      Attribute: RO  
 Default Value: 00170020h                          Size: 32 bits

Each I/O APIC contains a hardwired Version Register that identifies different implementation of APIC and their versions. The maximum redirection entry information also is in this register, to let software know how many interrupt are supported by this APIC.

Bit	Description
31:24	Reserved
23:16	Maximum Redirection Entries — RO. This is the entry number (0 being the lowest entry) of the highest entry in the redirection table. It is equal to the number of interrupt input pins minus one and is in the range 0 through 239. In the ICH8 this field is hardwired to 17h to indicate 24 interrupts.
15	PRQ — RO. Indicate that the IOxAPIC does not implement the Pin Assertion Register.
14:8	Reserved
7:0	Version — RO. This is a version number that identifies the implementation version.



### 9.5.7 REDIR\_TBL—Redirection Table (LPC I/F—D31:F0)

Index Offset:	10h–11h (vector 0) through 3E–3Fh (vector 23)	Attribute:	R/W, RO
Default Value:	Bit 16 = 1, All other bits undefined	Size:	64 bits each, (accessed as two 32 bit quantities)

The Redirection Table has a dedicated entry for each interrupt input pin. The information in the Redirection Table is used to translate the interrupt manifestation on the corresponding interrupt pin into an APIC message.

The APIC will respond to an edge triggered interrupt as long as the interrupt is held until after the acknowledge cycle has begun. Once the interrupt is detected, a delivery status bit internally to the I/O APIC is set. The state machine will step ahead and wait for an acknowledgment from the APIC unit that the interrupt message was sent. Only then will the I/O APIC be able to recognize a new edge on that interrupt pin. That new edge will only result in a new invocation of the handler if its acceptance by the destination APIC causes the Interrupt Request Register bit to go from 0 to 1. (In other words, if the interrupt was not already pending at the destination.)

Bit	Description
63:56	<b>Destination</b> — R/W. If bit 11 of this entry is 0 (Physical), then bits 59:56 specifies an APIC ID. In this case, bits 63:59 should be programmed by software to 0. If bit 11 of this entry is 1 (Logical), then bits 63:56 specify the logical destination address of a set of processors.
55:48	<b>Extended Destination ID (EDID)</b> — RO. These bits are sent to a local APIC only when in Processor System Bus mode. They become bits 11:4 of the address.
47:17	Reserved
16	<b>Mask</b> — R/W. 0 = Not masked: An edge or level on this interrupt pin results in the delivery of the interrupt to the destination. 1 = Masked: Interrupts are not delivered nor held pending. Setting this bit after the interrupt is accepted by a local APIC has no effect on that interrupt. This behavior is identical to the device withdrawing the interrupt before it is posted to the processor. It is software's responsibility to deal with the case where the mask bit is set after the interrupt message has been accepted by a local APIC unit but before the interrupt is dispensed to the processor.
15	<b>Trigger Mode</b> — R/W. This field indicates the type of signal on the interrupt pin that triggers an interrupt. 0 = Edge triggered. 1 = Level triggered.
14	<b>Remote IRR</b> — R/W. This bit is used for level triggered interrupts; its meaning is undefined for edge triggered interrupts. 0 = Reset when an EOI message is received from a local APIC. 1 = Set when Local APIC/s accept the level interrupt sent by the I/O APIC.
13	<b>Interrupt Input Pin Polarity</b> — R/W. This bit specifies the polarity of each interrupt signal connected to the interrupt pins. 0 = Active high. 1 = Active low.
12	<b>Delivery Status</b> — RO. This field contains the current status of the delivery of this interrupt. Writes to this bit have no effect. 0 = Idle. No activity for this interrupt. 1 = Pending. Interrupt has been injected, but delivery is not complete.



Bit	Description
11	<b>Destination Mode</b> — R/W. This field determines the interpretation of the Destination field. 0 = Physical. Destination APIC ID is identified by bits 59:56. 1 = Logical. Destinations are identified by matching bit 63:56 with the Logical Destination in the Destination Format Register and Logical Destination Register in each Local APIC.
10:8	<b>Delivery Mode</b> — R/W. This field specifies how the APICs listed in the destination field should act upon reception of this signal. Certain Delivery Modes will only operate as intended when used in conjunction with a specific trigger mode. These encodings are listed in the note below:
7:0	<b>Vector</b> — R/W. This field contains the interrupt vector for this interrupt. Values range between 10h and FEh.

**NOTE:** Delivery Mode encoding:

- 000 = Fixed. Deliver the signal on the INTR signal of all processor cores listed in the destination. Trigger Mode can be edge or level.
- 001 = Lowest Priority. Deliver the signal on the INTR signal of the processor core that is executing at the lowest priority among all the processors listed in the specified destination. Trigger Mode can be edge or level.
- 010 = SMI (System Management Interrupt). Requires the interrupt to be programmed as edge triggered. The vector information is ignored but must be programmed to all 0's for future compatibility: **not supported**
- 011 = Reserved
- 100 = NMI. Deliver the signal on the NMI signal of all processor cores listed in the destination. Vector information is ignored. NMI is treated as an edge triggered interrupt even if it is programmed as level triggered. For proper operation this redirection table entry must be programmed to edge triggered. The NMI delivery mode does not set the RIRR bit. If the redirection table is incorrectly set to level, the loop count will continue counting through the redirection table addresses. Once the count for the NMI pin is reached again, the interrupt will be sent again: **not supported**
- 101 = INIT. Deliver the signal to all processor cores listed in the destination by asserting the INIT signal. All addressed local APICs will assume their INIT state. INIT is always treated as an edge triggered interrupt even if programmed as level triggered. For proper operation this redirection table entry must be programmed to edge triggered. The INIT delivery mode does not set the RIRR bit. If the redirection table is incorrectly set to level, the loop count will continue counting through the redirection table addresses. Once the count for the INIT pin is reached again, the interrupt will be sent again: **not supported**
- 110 = Reserved
- 111 = ExtINT. Deliver the signal to the INTR signal of all processor cores listed in the destination as an interrupt that originated in an externally connected 8259A compatible interrupt controller. The INTA cycle that corresponds to this ExtINT delivery will be routed to the external controller that is expected to supply the vector. Requires the interrupt to be programmed as edge triggered.





## 9.6 Real Time Clock Registers (LPC I/F—D31:F0)

### 9.6.1 I/O Register Address Map (LPC I/F—D31:F0)

The RTC internal registers and RAM are organized as two banks of 128 bytes each, called the standard and extended banks. The first 14 bytes of the standard bank contain the RTC time and date information along with four registers, A–D, that are used for configuration of the RTC. The extended bank contains a full 128 bytes of battery backed SRAM, and will be accessible even when the RTC module is disabled (via the RTC configuration register). Registers A–D do not physically exist in the RAM.

All data movement between the host processor and the real-time clock is done through registers mapped to the standard I/O space. The register map appears in [Table 110](#).

**Table 110. RTC I/O Registers (LPC I/F—D31:F0)**

I/O Locations	If U128E bit = 0	Function
70h and 74h	Also alias to 72h and 76h	Real-Time Clock (Standard RAM) Index Register
71h and 75h	Also alias to 73h and 77h	Real-Time Clock (Standard RAM) Target Register
72h and 76h		Extended RAM Index Register (if enabled)
73h and 77h		Extended RAM Target Register (if enabled)

**NOTES:**

1. I/O locations 70h and 71h are the standard legacy location for the real-time clock. The map for this bank is shown in [Table 111](#). Locations 72h and 73h are for accessing the extended RAM. The extended RAM bank is also accessed using an indexed scheme. I/O address 72h is used as the address pointer and I/O address 73h is used as the data register. Index addresses above 127h are not valid. If the extended RAM is not needed, it may be disabled.
2. Software must preserve the value of bit 7 at I/O addresses 70h and 74h. When writing to this address, software must first read the value, and then write the same value for bit 7 during the sequential address write. Note that port 70h is not directly readable. The only way to read this register is through Alt Access mode. Although RTC Index bits 6:0 are readable from port 74h, bit 7 will always return 0. If the NMI# enable is not changed during normal operation, software can alternatively read this bit once and then retain the value for all subsequent writes to port 70h.



### 9.6.2 Indexed Registers (LPC I/F—D31:F0)

The RTC contains two sets of indexed registers that are accessed using the two separate Index and Target registers (70/71h or 72/73h), as shown in [Table 111](#).

**Table 111. RTC (Standard) RAM Bank (LPC I/F—D31:F0)**

Index	Name
00h	Seconds
01h	Seconds Alarm
02h	Minutes
03h	Minutes Alarm
04h	Hours
05h	Hours Alarm
06h	Day of Week
07h	Day of Month
08h	Month
09h	Year
0Ah	Register A
0Bh	Register B
0Ch	Register C
0Dh	Register D
0Eh–7Fh	114 Bytes of User RAM



### 9.6.2.1 RTC\_REGA—Register A (LPC I/F—D31:F0)

RTC Index:	0A	Attribute:	R/W
Default Value:	Undefined	Size:	8-bit
Lockable:	No	Power Well:	RTC

This register is used for general configuration of the RTC functions. None of the bits are affected by RSMRST# or any other ICH8 reset signal.

Bit	Description
7	<p><b>Update In Progress (UIP)</b> — R/W. This bit may be monitored as a status flag.</p> <p>0 = The update cycle will not start for at least 488 <math>\mu</math>s. The time, calendar, and alarm information in RAM is always available when the UIP bit is 0.</p> <p>1 = The update is soon to occur or is in progress.</p>
6:4	<p><b>Division Chain Select (DV[2:0])</b> — R/W. These three bits control the divider chain. The division chain itself is reset by RSMRST# to all 0's and it can also be cleared to 0's by firmware thru programming of DV. The periodic event (setting of RTCIS.PF and the associated interrupt) can be based on the time as measured from RSMRST# deassertion until a divider reset (DV='11x' to '010') is performed by firmware. DV2 corresponds to bit 6.</p> <p>010 = Normal Operation            11X = Divider Reset            101 = Bypass 15 stages (test mode only)            100 = Bypass 10 stages (test mode only)            011 = Bypass 5 stages (test mode only)            001 = Invalid            000 = Invalid</p>
3:0	<p><b>Rate Select (RS[3:0])</b> — R/W. Selects one of 13 taps of the 15 stage divider chain. The selected tap can generate a periodic interrupt if the PIE bit is set in Register B. Otherwise this tap will set the PF flag of Register C. If the periodic interrupt is not to be used, these bits should all be set to 0. RS3 corresponds to bit 3.</p> <p>0000 = Interrupt never toggles            0001 = 3.90625 ms            0010 = 7.8125 ms            0011 = 122.070 <math>\mu</math>s            0100 = 244.141 <math>\mu</math>s            0101 = 488.281 <math>\mu</math>s            0110 = 976.5625 <math>\mu</math>s            0111 = 1.953125 ms            1000 = 3.90625 ms            1001 = 7.8125 ms            1010 = 15.625 ms            1011 = 31.25 ms            1100 = 62.5 ms            1101 = 125 ms            1110 = 250 ms            1111 = 500 ms</p>



9.6.2.2 **RTC\_REGB—Register B (General Configuration)**  
(LPC I/F—D31:F0)

RTC Index:	0Bh	Attribute:	R/W
Default Value:	U0U00UUU (U: Undefined)	Size:	8-bit
Lockable:	No	Power Well:	RTC

Bit	Description
7	<p><b>Update Cycle Inhibit (SET)</b> — R/W. Enables/Inhibits the update cycles. This bit is not affected by RSMRST# nor any other reset signal.</p> <p>0 = Update cycle occurs normally once each second. 1 = A current update cycle will abort and subsequent update cycles will not occur until SET is returned to 0. When set is one, the BIOS may initialize time and calendar bytes safely.</p> <p><b>NOTE:</b> This bit should be set then cleared early in BIOS POST after each powerup directly after coin-cell battery insertion.</p>
6	<p><b>Periodic Interrupt Enable (PIE)</b> — R/W. This bit is cleared by RSMRST#, but not on any other reset.</p> <p>0 = Disable. 1 = Enable. Allows an interrupt to occur with a time base set with the RS bits of register A.</p>
5	<p><b>Alarm Interrupt Enable (AIE)</b> — R/W. This bit is cleared by RTCRST#, but not on any other reset.</p> <p>0 = Disable. 1 = Enable. Allows an interrupt to occur when the AF is set by an alarm match from the update cycle. An alarm can occur once a second, one an hour, once a day, or one a month.</p>
4	<p><b>Update-Ended Interrupt Enable (UIE)</b> — R/W. This bit is cleared by RSMRST#, but not on any other reset.</p> <p>0 = Disable. 1 = Enable. Allows an interrupt to occur when the update cycle ends.</p>
3	<p><b>Square Wave Enable (SQWE)</b> — R/W. This bit serves no function in the ICH8. It is left in this register bank to provide compatibility with the Motorola 146818B. The ICH8 has no SQW pin. This bit is cleared by RSMRST#, but not on any other reset.</p>
2	<p><b>Data Mode (DM)</b> — R/W. This bit specifies either binary or BCD data representation. This bit is not affected by RSMRST# nor any other reset signal.</p> <p>0 = BCD 1 = Binary</p>
1	<p><b>Hour Format (HOURFORM)</b> — R/W. This bit indicates the hour byte format. This bit is not affected by RSMRST# nor any other reset signal.</p> <p>0 = Twelve-hour mode. In twelve-hour mode, the seventh bit represents AM as 0 and PM as one. 1 = Twenty-four hour mode.</p>
0	<p><b>Daylight Savings Enable (DSE)</b> — R/W. This bit triggers two special hour updates per year. The days for the hour adjustment are those specified in United States federal law as of 1987, which is different than previous years. This bit is not affected by RSMRST# nor any other reset signal.</p> <p>0 = Daylight Savings Time updates do not occur. 1 = a) Update on the first Sunday in April, where time increments from 1:59:59 AM to 3:00:00 AM. b) Update on the last Sunday in October when the time first reaches 1:59:59 AM, it is changed to 1:00:00 AM. The time must increment normally for at least two update cycles (seconds) previous to these conditions for the time change to occur properly.</p>



### 9.6.2.3 RTC\_REGC—Register C (Flag Register) (LPC I/F—D31:F0)

RTC Index:	0Ch	Attribute:	RO
Default Value:	00U00000 (U: Undefined)	Size:	8-bit
Lockable:	No	Power Well:	RTC

Writes to Register C have no effect.

Bit	Description
7	<b>Interrupt Request Flag (IRQF)</b> — RO. $IRQF = (PF * PIE) + (AF * AIE) + (UF * UFE)$ . This bit also causes the RTC Interrupt to be asserted. This bit is cleared upon RSMRST# or a read of Register C.
6	<b>Periodic Interrupt Flag (PF)</b> — RO. This bit is cleared upon RSMRST# or a read of Register C. 0 = If no taps are specified via the RS bits in Register A, this flag will not be set. 1 = Periodic interrupt Flag will be 1 when the tap specified by the RS bits of register A is 1.
5	<b>Alarm Flag (AF)</b> — RO. 0 = This bit is cleared upon RTCRST# or a read of Register C. 1 = Alarm Flag will be set after all Alarm values match the current time.
4	<b>Update-Ended Flag (UF)</b> — RO. 0 = The bit is cleared upon RSMRST# or a read of Register C. 1 = Set immediately following an update cycle for each second.
3:0	Reserved. Will always report 0.

### 9.6.2.4 RTC\_REGD—Register D (Flag Register) (LPC I/F—D31:F0)

RTC Index:	0Dh	Attribute:	R/W
Default Value:	10UUUUUU (U: Undefined)	Size:	8-bit
Lockable:	No	Power Well:	RTC

Bit	Description
7	<b>Valid RAM and Time Bit (VRT)</b> — R/W. 0 = This bit should always be written as a 0 for write cycle, however it will return a 1 for read cycles. 1 = This bit is hardwired to 1 in the RTC power well.
6	Reserved. This bit always returns a 0 and should be set to 0 for write cycles.
5:0	<b>Date Alarm</b> — R/W. These bits store the date of month alarm value. If set to 000000b, then a don't care state is assumed. The host must configure the date alarm for these bits to do anything, yet they can be written at any time. If the date alarm is not enabled, these bits will return 0's to mimic the functionality of the Motorola 146818B. These bits are not affected by any reset assertion.



## 9.7 Processor Interface Registers (LPC I/F—D31:F0)

Table 112 is the register address map for the processor interface registers.

Table 112. Processor Interface PCI Register Address Map (LPC I/F—D31:F0)

Offset	Mnemonic	Register Name	Default	Type
61h	NMI_SC	NMI Status and Control	00h	R/W, RO
70h	NMI_EN	NMI Enable	80h	R/W (special)
92h	PORT92	Fast A20 and Init	00h	R/W
F0h	COPROC_ERR	Coprocessor Error	00h	WO
CF9h	RST_CNT	Reset Control	00h	R/W

### 9.7.1 NMI\_SC—NMI Status and Control Register (LPC I/F—D31:F0)

I/O Address:	61h	Attribute:	R/W, RO
Default Value:	00h	Size:	8-bit
Lockable:	No	Power Well:	Core

Bit	Description
7	<p><b>SERR# NMI Source Status (SERR#_NMI_STS) — RO.</b></p> <p>1 = Bit is set if a PCI agent detected a system error and pulses the PCI SERR# line and if bit 2 (PCI_SERR_EN) is cleared. This interrupt source is enabled by setting bit 2 to 0. To reset the interrupt, set bit 2 to 1 and then set it to 0. When writing to port 61h, this bit must be 0.</p> <p><b>NOTE:</b> This bit is set by any of the ICH8 internal sources of SERR; this includes SERR assertions forwarded from the secondary PCI bus, errors on a PCI Express* port, or other internal functions that generate SERR#.</p>
6	<p><b>IOCHK# NMI Source Status (IOCHK_NMI_STS) — RO.</b></p> <p>1 = Bit is set if an LPC agent (via SERIRO) asserted IOCHK# and if bit 3 (IOCHK_NMI_EN) is cleared. This interrupt source is enabled by setting bit 3 to 0. To reset the interrupt, set bit 3 to 1 and then set it to 0. When writing to port 61h, this bit must be a 0.</p>
5	<p><b>Timer Counter 2 OUT Status (TMR2_OUT_STS) — RO.</b> This bit reflects the current state of the 8254 counter 2 output. Counter 2 must be programmed following any PCI reset for this bit to have a determinate value. When writing to port 61h, this bit must be a 0.</p>
4	<p><b>Refresh Cycle Toggle (REF_TOGGLE) — RO.</b> This signal toggles from either 0 to 1 or 1 to 0 at a rate that is equivalent to when refresh cycles would occur. When writing to port 61h, this bit must be a 0.</p>
3	<p><b>IOCHK# NMI Enable (IOCHK_NMI_EN) — R/W.</b></p> <p>0 = Enabled. 1 = Disabled and cleared.</p>
2	<p><b>PCI SERR# Enable (PCI_SERR_EN) — R/W.</b></p> <p>0 = SERR# NMIs are enabled. 1 = SERR# NMIs are disabled and cleared.</p>



Bit	Description
1	<b>Speaker Data Enable (SPKR_DAT_EN)</b> — R/W. 0 = SPKR output is a 0. 1 = SPKR output is equivalent to the Counter 2 OUT signal value.
0	<b>Timer Counter 2 Enable (TIM_CNT2_EN)</b> — R/W. 0 = Disable 1 = Enable

### 9.7.2 NMI\_EN—NMI Enable (and Real Time Clock Index) Register (LPC I/F—D31:F0)

I/O Address:	70h	Attribute:	R/W (special)
Default Value:	80h	Size:	8-bit
Lockable:	No	Power Well:	Core

**Note:** The RTC Index field is write-only for normal operation. This field can only be read in Alt-Access Mode. Note, however, that this register is aliased to Port 74h (documented in), and all bits are readable at that address.

Bits	Description
7	<b>NMI Enable (NMI_EN)</b> — R/W (special). 0 = Enable NMI sources. 1 = Disable All NMI sources.
6:0	<b>Real Time Clock Index Address (RTC_INDX)</b> — R/W (special). This data goes to the RTC to select which register or CMOS RAM address is being accessed.

### 9.7.3 PORT92—Fast A20 and Init Register (LPC I/F—D31:F0)

I/O Address:	92h	Attribute:	R/W
Default Value:	00h	Size:	8-bit
Lockable:	No	Power Well:	Core

Bit	Description
7:2	Reserved
1	<b>Alternate A20 Gate (ALT_A20_GATE)</b> — R/W. This bit is Or'd with the A20GATE input signal to generate A20M# to the processor. 0 = A20M# signal can potentially go active. 1 = This bit is set when INIT# goes active.
0	<b>INIT_NOW</b> — R/W. When this bit transitions from a 0 to a 1, the ICH8 will force INIT# active for 16 PCI clocks.



### 9.7.4 COPROC\_ERR—Coprocessor Error Register (LPC I/F—D31:F0)

I/O Address: F0h Attribute: WO  
 Default Value: 00h Size: 8-bits  
 Lockable: No Power Well: Core

Bits	Description
7:0	<b>Coprocessor Error (COPROC_ERR)</b> — WO. Any value written to this register will cause IGNNE# to go active, if FERR# had generated an internal IRQ13. For FERR# to generate an internal IRQ13, the COPROC_ERR_EN bit (Chipset Configuration Register, Offset 31FFh, bit 1) must be 1.

### 9.7.5 RST\_CNT—Reset Control Register (LPC I/F—D31:F0)

I/O Address: CF9h Attribute: R/W  
 Default Value: 00h Size: 8-bit  
 Lockable: No Power Well: Core

Bit	Description
7:4	Reserved
3	<b>Full Reset (FULL_RST)</b> — R/W. This bit is used to determine the states of SLP_S3#, SLP_S4#, and SLP_S5# after a CF9 hard reset (SYS_RST = 1 and RST_CPU is set to 1), after PWROK going low (with RSMRST# high), or after two TCO timeouts. 0 = ICH8 will keep SLP_S3#, SLP_S4# and SLP_S5# high. 1 = ICH8 will drive SLP_S3#, SLP_S4# and SLP_S5# low for 3 – 5 seconds.  <b>NOTE:</b> When this bit is set, it also causes the full power cycle (SLP_S3/4/5# assertion) in response to SYSRESET#, PWROK#, and Watchdog timer reset sources.
2	<b>Reset CPU (RST_CPU)</b> — R/W. When this bit transitions from a 0 to a 1, it initiates a hard or soft reset, as determined by the SYS_RST bit (bit 1 of this register).
1	<b>System Reset (SYS_RST)</b> — R/W. This bit is used to determine a hard or soft reset to the processor. 0 = When RST_CPU bit goes from 0 to 1, the ICH8 performs a soft reset by activating INIT# for 16 PCI clocks. 1 = When RST_CPU bit goes from 0 to 1, the ICH8 performs a hard reset by activating PLTRST# and SUS_STAT# active for about 5-6 milliseconds. In this case, SLP_S#3, SLP_S4#, and SLP_S5# state (assertion or de-assertion) depends on FULL_RST bit setting. The ICH8 main power well is reset when this bit is 1. It also resets the resume well bits (except for those noted throughout the datasheet).
0	Reserved





## 9.8 Power Management Registers (PM—D31:F0)

The power management registers are distributed within the PCI Device 31: Function 0 space, as well as a separate I/O range. Each register is described below. Unless otherwise indicate, bits are in the main (core) power well.

Bits not explicitly defined in each register are assumed to be reserved. When writing to a reserved bit, the value should always be 0. Software should not attempt to use the value read from a reserved bit, as it may not be consistently 1 or 0.

### 9.8.1 Power Management PCI Configuration Registers (PM—D31:F0)

Table 113 shows a small part of the configuration space for PCI Device 31: Function 0. It includes only those registers dedicated for power management. Some of the registers are only used for Legacy Power management schemes.

**Table 113. Power Management PCI Register Address Map (PM—D31:F0)**

Offset	Mnemonic	Register Name	Default	Type
A0h	GEN_PMCON_1	General Power Management Configuration 1	0000h	R/W, RO, R/WO
A2h	GEN_PMCON_2	General Power Management Configuration 2	00h	R/W, R/WC
A4h	GEN_PMCON_3	General Power Management Configuration 3	00h	R/W, R/WC
A9h	Cx-STATE_CNF	Cx State Configuration (Mobile Only).	00h	R/W
AAh	C4-TIMING_CNT	C4 Timing Control (Mobile Only).	00h	R/W
ABh	BM_BREAK_EN	BM_BREAK_EN (Mobile Only)	00h	R/W
ACh	PMIR	Power Management Initialization	00h	R/W
ADh	MSC_FUN	Miscellaneous Functionality	00h	R/W
B0h	QRT_STS	Quick Resume Technology Status Register (ICH8DH Only)	00h	R/WC, RO
B1h-B2h	QRT_CNTL1	Quick Resume Technology Control 1 Register (ICH8DH Only)	F000h	R/W, RO, WO
B3h	QRT_CNTL2	Quick Resume Technology Control 2 Register (ICH8DH Only)	00h	R/W, RO
B8-BBh	GPI_ROUT	GPI Route Control	00000000h	R/W



### 9.8.1.1 GEN\_PMCON\_1—General PM Configuration 1 Register (PM—D31:F0)

Offset Address:	A0h	Attribute:	R/W, RO, R/WO
Default Value:	0000h	Size:	16-bit
Lockable:	No	Usage:	ACPI, Legacy
		Power Well:	Core

Bit	Description												
15:13	Reserved												
12 (Desktop Only)	Reserved												
12 (Mobile Only)	<p><b>C4 Disable:</b> This bit disables the C4 feature.</p> <p>0 = Enables C4 1 = Disables C4</p>												
11 (Desktop)	Reserved												
11 (Mobile Only)	<p><b>C5_Enable:</b> This bit enables the C5 and C6 features. When this bit is 0, the platform does not enable the C5 and C6 features. When this bit is 1, the platform enables C5/C6 features.</p> <p>This bit also, along with GPIO_USE_SEL[0] bit, enables selection of BM_BUSY#/PMSYNC# function on ICH pin as shown below:</p> <table border="1" style="margin-left: 40px;"> <thead> <tr> <th>GPIO_USE_SEL[0]</th> <th>C5_Enable</th> <th>Result</th> </tr> </thead> <tbody> <tr> <td>1</td> <td>X</td> <td>GPIO</td> </tr> <tr> <td>0</td> <td>0</td> <td>BM_BUSY#</td> </tr> <tr> <td>0</td> <td>1</td> <td>PMSYNC#</td> </tr> </tbody> </table> <p>When this bit is 0:</p> <ul style="list-style-type: none"> <li>• The R/W bits of the C5 Exit Timing Register become scratchpad with no effect on hardware functions.</li> <li>• I/O Reads to the LVL5 and LVL6 registers will be retired normally, but with no other action.</li> <li>• All attempts to enter deeper C-States that require a transition through the C5 timing logic will be ignored.</li> </ul>	GPIO_USE_SEL[0]	C5_Enable	Result	1	X	GPIO	0	0	BM_BUSY#	0	1	PMSYNC#
GPIO_USE_SEL[0]	C5_Enable	Result											
1	X	GPIO											
0	0	BM_BUSY#											
0	1	PMSYNC#											
10	<p><b>BIOS_PCI_EXP_EN</b> — R/W. This bit acts as a global enable for the SCI associated with the PCI Express* ports.</p> <p>0 = The various PCI Express ports and (G)MCH cannot cause the PCI_EXP_STS bit to go active.</p> <p>1 = The various PCI Express ports and (G)MCH can cause the PCI_EXP_STS bit to go active.</p>												
9	<p><b>PWRBTN_LVL</b> — RO. This bit indicates the current state of the PWRBTN# signal.</p> <p>0 = Low. 1 = High.</p>												
8	Reserved												
7 (Desktop Only)	Reserved												
7 (Mobile Only)	<p><b>Enter C4 When C3 Invoked (C4onC3_EN)</b> — R/W. If this bit is set, then when software does a LVL3 read, the ICH8 transitions to the C4 state.</p>												



Bit	Description
6	<b>i64_EN.</b> Software sets this bit to indicate that the processor is an IA_64 processor, not an IA_32 processor. This may be used in various state machines where there are behavioral differences.
5	<b>CPU SLP# Enable (CPUSLP_EN)</b> — R/W. 0 = Disable. 1 = Enables the CPUSLP# signal to go active in the S1 state. This reduces the processor power.  <b>NOTE:</b> CPUSLP# will go active during Intel SpeedStep® technology transitions and on entry to C3 and C4 states even if this bit is not set.
4	<b>SMI_LOCK</b> — R/WO. When this bit is set, writes to the GLB_SMI_EN bit (PMBASE + 30h, bit 0) will have no effect. Once the SMI_LOCK bit is set, writes of 0 to SMI_LOCK bit will have no effect (i.e., once set, this bit can only be cleared by PLTRST#).
3:2 (Desktop Only)	Reserved
3 (Mobile Only)	<b>Intel SpeedStep Enable (SS_EN)</b> — R/W. 0 = Intel SpeedStep technology logic is disabled and the SS_CNT register will not be visible (reads to SS_CNT will return 00h and writes will have no effect). 1 = Intel SpeedStep technology logic is enabled.
2 (Mobile Only)	<b>PCI CLKRUN# Enable (CLKRUN_EN)</b> — R/W. 0 = Disable. ICH8 drives the CLKRUN# signal low. 1 = Enable CLKRUN# logic to control the system PCI clock via the CLKRUN# and STP_PCI# signals.  <b>NOTE:</b> when the SLP_EN# bit is set, the ICH8 drives the CLKRUN# signal low regardless of the state of the CLKRUN_EN bit. This ensures that the PCI and LPC clocks continue running during a transition to a sleep state.
1:0	Periodic SMI# Rate Select (PER_SMI_SEL) — R/W. Set by software to control the rate at which periodic SMI# is generated. 00 = 64 seconds 01 = 32 seconds 10 = 16 seconds 11 = 8 seconds



### 9.8.1.2 GEN\_PMCON\_2—General PM Configuration 2 Register (PM—D31:FO)

Offset Address:	A2h	Attribute:	R/W, R/WC
Default Value:	00h	Size:	8-bit
Lockable:	No	Usage:	ACPI, Legacy
		Power Well:	Resume

Bit	Description
7	<p><b>DRAM Initialization Bit</b> — R/W. This bit does not effect hardware functionality in any way. BIOS is expected to set this bit prior to starting the DRAM initialization sequence and to clear this bit after completing the DRAM initialization sequence. BIOS can detect that a DRAM initialization sequence was interrupted by a reset by reading this bit during the boot sequence.</p> <ul style="list-style-type: none"> <li>If the bit is 1, then the DRAM initialization was interrupted.</li> <li>This bit is reset by the assertion of the RSMRST# pin.</li> </ul>
6:5 (Desktop Only)	Reserved
6:5 (Mobile Only)	<p><b>CPU PLL Lock Time (CPLT)</b> — R/W. This field indicates the amount of time that the processor needs to lock its PLLs. This is used wherever timing t250–t274 (see <a href="#">Chapter 23</a>) applies.</p> <p>00 = min 30.7 <math>\mu</math>s (Default)            01 = min 61.4 <math>\mu</math>s            10 = min 122.8 <math>\mu</math>s            11 = min 245.6 <math>\mu</math>s</p> <p>It is the responsibility of the BIOS to program the correct value in this field prior to the first transition to C3 or C4 states (or performing Intel SpeedStep technology transitions).</p> <p><b>NOTE:</b> The new DPSLP-TO-SLP bits (D31:FO:AAh, bits 1:0) act as an override to these bits.</p> <p><b>NOTE:</b> These bits are not cleared by any type of reset except RSMRST# or a CF9 write</p>
4	<p><b>System Reset Status (SRS)</b> — R/WC. Software clears this bit by writing a 1 to it.</p> <p>0 = SYS_RESET# button Not pressed.            1 = ICH8 sets this bit when the SYS_RESET# button is pressed. BIOS is expected to read this bit and clear it, if it is set.</p> <p><b>NOTE:</b> This bit is also reset by RSMRST# and CF9h resets.</p>
3	<p><b>CPU Thermal Trip Status (CTS)</b> — R/WC.</p> <p>0 = Software clears this bit by writing a 1 to it.            1 = This bit is set when PLTRST# is inactive and THRMTRIP# goes active while the system is in an S0 or S1 state.</p> <p><b>NOTES:</b></p> <ol style="list-style-type: none"> <li>This bit is also reset by RSMRST#, and CF9h resets. It is not reset by the shutdown and reboot associated with the CPUTHRMTRIP# event.</li> <li>The CF9h reset in the description refers to CF9h type core well reset which includes SYS_RST#, PWROK/VRMPWRGD low, SMBus hard reset, TCO Timeout. This type of reset will clear CTS bit.</li> </ol>



Bit	Description
2	<p><b>Minimum SLP_S4# Assertion Width Violation Status</b> — R/WC.</p> <p>0 = Software clears this bit by writing a 1 to it.            1 = Hardware sets this bit when the SLP_S4# assertion width is less than the time programmed in the SLP_S4# Minimum Assertion Width field (D31:F0:Offset A4h:bits 5:4). The ICH8 begins the timer when SLP_S4# is asserted during S4/S5 entry, or when the RSMRST# input is deasserted during G3 exit. Note that this bit is functional regardless of the value in the SLP_S4# Assertion Stretch Enable (D31:F0:Offset A4h:bit 3).</p> <p><b>NOTE:</b> This bit is reset by the assertion of the RSMRST# pin, but can be set in some cases before the default value is readable.</p>
1	<p><b>CPU Power Failure (CPUPWR_FLR)</b> — R/W.</p> <p>0 = Software (typically BIOS) clears this bit by writing a 0 to it.            1 = Indicates that the VRMPWRGD signal from the processor's VRM went low while the system was in an S0 or S1 state.</p> <p><b>NOTE:</b> VRMPWRGD is sampled using the RTC clock. Therefore, low times that are less than one RTC clock period may not be detected by the Intel ICH8.</p>
0	<p><b>PWROK Failure (PWROK_FLR)</b> — R/WC.</p> <p>0 = Software clears this bit by writing a 1 to it, or when the system goes into a G3 state.            1 = This bit will be set any time PWROK goes low, when the system was in S0, or S1 state. The bit will be cleared only by software by writing a 1 to this bit or when the system goes to a G3 state.</p> <p><b>NOTE:</b> See <a href="#">Chapter 5.13.11.3</a> for more details about the PWROK pin functionality.  <b>NOTE:</b> In the case of true PWROK failure, PWROK will go low first before the VRMPWRGD.</p>

**NOTE:** VRMPWROK is sampled using the RTC clock. Therefore, low times that are less than one RTC clock period may not be detected by the ICH8.

### 9.8.1.3 GEN\_PMCON\_3—General PM Configuration 3 Register (PM—D31:F0)

Offset Address:	A4h	Attribute:	R/W, R/WC
Default Value:	00h	Size:	16-bit
Lockable:	No	Usage:	ACPI, Legacy
		Power Well:	RTC

Bit	Description
15:9	Reserved
8	<p><b>S4_STATE# Pin Disable</b> — R/W.</p> <p>0 = The traditional SLP_S4# signal (without ME Overrides) is driven on the S4_STATE# Pin.            1 = The S4_STATE# pin functionality is disabled and the pin can be used for other functionality.</p> <p>This bit is cleared by RTCRST#.</p>
7:6	<p><b>SWSMI_RATE_SEL</b> — R/W. This field indicates when the SWSMI timer will time out. Valid values are:</p> <p>00 = 1.5 ms ± 0.6 ms            01 = 16 ms ± 4 ms            10 = 32 ms ± 4 ms            11 = 64 ms ± 4 ms</p> <p>These bits are not cleared by any type of reset except RTCRST#.</p>



Bit	Description
5:4	<p><b>SLP_S4# Minimum Assertion Width</b> — R/W. This field indicates the minimum assertion width of the SLP_S4# signal to assure that the DRAMs have been safely power-cycled.</p> <p>Valid values are:</p> <p>11 = 1 to 2 seconds            10 = 2 to 3 seconds            01 = 3 to 4 seconds            00 = 4 to 5 seconds</p> <p>This value is used in two ways:</p> <ol style="list-style-type: none"> <li>If the SLP_S4# assertion width is ever shorter than this time, a status bit is set for BIOS to read when S0 is entered.</li> <li>If enabled by bit 3 in this register, the hardware will prevent the SLP_S4# signal from deasserting within this minimum time period after asserting.</li> </ol> <p>RTCRST# forces this field to the conservative default state (00b)</p>
3	<p><b>SLP_S4# Assertion Stretch Enable</b> — R/W.</p> <p>0 = The SLP_S4# minimum assertion time is 1 to 2 RTCCLK.            1 = The SLP_S4# signal minimally assert for the time specified in bits 5:4 of this register.</p> <p>This bit is cleared by RTCRST#</p>
2	<p><b>RTC Power Status (RTC_PWR_STS)</b> — R/W. This bit is set when RTCRST# indicates a weak or missing battery. The bit is not cleared by any type of reset. The bit will remain set until the software clears it by writing a 0 back to this bit position.</p>
1	<p><b>Power Failure (PWR_FLR)</b> — R/WC. This bit is in the RTC well, and is not cleared by any type of reset except RTCRST#.</p> <p>0 = Indicates that the trickle current has not failed since the last time the bit was cleared. Software clears this bit by writing a 1 to it.            1 = Indicates that the trickle current (from the main battery or trickle supply) was removed or failed.</p> <p><b>NOTE:</b> Clearing CMOS in an ICH-based platform can be done by using a jumper on RTCRST# or GPI, or using SAFEMODE strap. Implementations should not attempt to clear CMOS by using a jumper to pull VccRTC low.</p>
0	<p><b>AFTERG3_EN</b> — R/W. This bit determines what state to go to when power is re-applied after a power failure (G3 state). This bit is in the RTC well and is not cleared by any type of reset except writes to CF9h or RTCRST#.</p> <p>0 = System will return to S0 state (boot) after power is re-applied.            1 = System will return to the S5 state (except if it was in S4, in which case it will return to S4). In the S5 state, the only enabled wake event is the Power Button or any enabled wake event that was preserved through the power failure.</p> <p><b>NOTE:</b> Bit will be set when THRMTRIP#-based shutdown occurs.</p>

**NOTE:** RSMRST# is sampled using the RTC clock. Therefore, low times that are less than one RTC clock period may not be detected by the ICH8.



### 9.8.1.4 GEN\_PMCON\_LOCK—General Power Management Configuration Lock Register

Offset Address:	A6h	Attribute:	R/W
Default Value:	00h	Size:	8-bit
Lockable:	No	Usage:	ACPI
Power Well:	Core		

This register is used to enable new C-state related modes.

Bit	Description
7 (Mobile Only)	<b>Unlocked C-State Transition:</b> This bit is set by hardware when a CPU power state (C-State) transition deeper than C2 occurs and the C-STATE_CONFIG_LOCK bit is not set. This bit is cleared by PLTRST# and is not writable by software.
6:2 (Mobile Only) 7:2 (Desktop Only)	Reserved
1	<b>ACPI_BASE_LOCK:</b> When set to 1, this bit locks down the ACPI Base Address Register (ABASE) at offset 40h. The Base Address Field becomes read-only. This bit becomes locked when a value of 1b is written to it. Writes of 0 to this bit are always ignored. Once locked by writing 1, the only way to clear this bit is to perform a platform reset.
0 (Mobile Only)	<b>C-STATE_CONFIG_LOCK:</b> When set to 1, this bit locks down the C-State configuration parameters. The following configuration bits become read-only when this bit is set: <ul style="list-style-type: none"> <li>• GEYSERVILLE_EN (GEN_PMCON_1, bit 3)</li> <li>• IA64_EN (GEN_PMCON_1, bit 6)</li> <li>• C4_DISABLE (GEN_PMCON_1, bit 12)</li> <li>• CPU_PLL_LOCK_TIME (GEN_PMCON_2, bits 6:5)</li> <li>• The entire C4 Timing Control Register (C4_TIMING_CNT)</li> <li>• The entire C5 Exit Timing Register (C5_EXIT_TIMING_CNT)</li> </ul> This bit becomes locked when a value of 1b is written to it. Writes of 0 to this bit are always ignored. Once locked by writing 1, the only way to clear this bit is to perform a platform reset.
0 (Desktop Only)	Reserved



**9.8.1.5 Cx-STATE\_CNF—Cx State Configuration Register (PM—D31:F0) (Mobile Only)**

Offset Address:	A9h	Attribute:	R/W
Default Value:	00h	Size:	8-bit
Lockable:	No	Usage:	ACPI, Legacy
Power Well:	Core		

This register is used to enable new C-state related modes.

Bit	Description
7	<b>SCRATCHPAD (SP)</b> — R/W.
6:5	Reserved
4	<p><b>Popdown Mode Enable (PDME)</b> — R/W. This bit is used in conjunction with the PUME bit (D31:F0:A9h, bit 3). If PUME is 0, then this bit must also be 0.</p> <p>0 = The ICH8 will not attempt to automatically return to a previous C3 or C4 state.</p> <p>1 = When this bit is a 1 and Intel® ICH8 observes that there are no bus master requests, it can return to a previous C3 or C4 state.</p> <p><b>NOTE:</b> This bit is separate from the PUME bit to cover cases where latency issues permit POPUP but not POPDOWN.</p>
3	<p><b>Popup Mode Enable (PUME)</b> — R/W. When this bit is a 0, the ICH8 behaves like ICH5, in that bus master traffic is a break event, and it will return from C3/C4 to C0 based on a break event. See <a href="#">Chapter 5.13.5</a> for additional details on this mode.</p> <p>0 = The ICH8 will treat Bus master traffic a break event, and will return from C3/C4 to C0 based on a break event.</p> <p>1 = When this bit is a 1 and ICH8 observes a bus master request, it will take the system from a C3 or C4 state to a C2 state and auto enable bus masters. This will let snoops and memory access occur.</p>
2	<p><b>Report Zero for BM_STS (BM_STS_ZERO_EN)</b> — R/W.</p> <p>0 = The ICH8 sets BM_STS (PMBASE + 00h, bit 4) if there is bus master activity from PCI, PCI Express* and internal bus masters.</p> <p>1 = When this bit is a 1, ICH8 will not set the BM_STS if there is bus master activity from PCI, PCI Express and internal bus masters.</p> <p><b>NOTES:</b></p> <ol style="list-style-type: none"> <li>If the BM_STS bit is already set when the BM_STS_ZERO_EN bit is set, the BM_STS bit will remain set. Software will still need to clear the BM_STS bit.</li> <li>It is expected that if the PUME bit (this register, bit 3) is set, the BM_STS_ZERO_EN bit should also be set. Setting one without the other would mainly be for debug or errata workaround.</li> <li>BM_STS will be set by LPC DMA or LPC masters, even if BM_STS_ZERO_EN is set.</li> </ol>
1:0	Reserved





### 9.8.1.6 C4-TIMING\_CNT—C4 Timing Control Register (PM—D31:F0) (Mobile Only)

Offset Address:	AAh	Attribute:	R/W
Default Value:	00h	Size:	8-bit
Lockable:	No	Usage:	ACPI, Legacy
Power Well:	Core		

This register is used to enable C-state related modes.

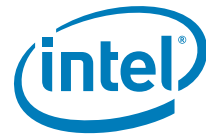
Bit	Description																				
7	Reserved																				
6	<b>Slow-C4 Exit Enable</b> —When 1, this bit enables the Slow-C4 Exit functionality.																				
5:4	<p><b>Slow-C4 Exit Delay.</b> This field selects the amount of time that the ICH8 waits from deassertion of DPRSTP# until starting the t266 timer when performing the Slow-C4 exit.</p> <table> <thead> <tr> <th>Bits</th> <th>Min</th> <th>Max</th> <th>Comment</th> </tr> </thead> <tbody> <tr> <td>00b</td> <td>73 <math>\mu</math>s</td> <td>76 <math>\mu</math>s</td> <td>Default. compatible with 01b setting of t266</td> </tr> <tr> <td>01b</td> <td>67 <math>\mu</math>s</td> <td>70 <math>\mu</math>s</td> <td></td> </tr> <tr> <td>10b</td> <td>61 <math>\mu</math>s</td> <td>64 <math>\mu</math>s</td> <td>compatible with 10b setting of t266</td> </tr> <tr> <td>11b</td> <td>46 <math>\mu</math>s</td> <td>49 <math>\mu</math>s</td> <td>compatible with 11b setting of t266</td> </tr> </tbody> </table>	Bits	Min	Max	Comment	00b	73 $\mu$ s	76 $\mu$ s	Default. compatible with 01b setting of t266	01b	67 $\mu$ s	70 $\mu$ s		10b	61 $\mu$ s	64 $\mu$ s	compatible with 10b setting of t266	11b	46 $\mu$ s	49 $\mu$ s	compatible with 11b setting of t266
Bits	Min	Max	Comment																		
00b	73 $\mu$ s	76 $\mu$ s	Default. compatible with 01b setting of t266																		
01b	67 $\mu$ s	70 $\mu$ s																			
10b	61 $\mu$ s	64 $\mu$ s	compatible with 10b setting of t266																		
11b	46 $\mu$ s	49 $\mu$ s	compatible with 11b setting of t266																		
3:2	<p><b>DPRSLPVR to STPCPU</b> — R/W. This field selects the amount of time that the ICH8 waits for from the deassertion of DPRSLPVR to the deassertion of STP_CPU#. This provides a programmable time for the processor's voltage to stabilize when exiting from a C4 state. Thus, this changes the value for t266.</p> <table> <thead> <tr> <th>Bits</th> <th>t266<sub>min</sub></th> <th>t266<sub>max</sub></th> <th>Comment</th> </tr> </thead> <tbody> <tr> <td>00b</td> <td>95 <math>\mu</math>s</td> <td>101 <math>\mu</math>s</td> <td>Default</td> </tr> <tr> <td>01b</td> <td>22 <math>\mu</math>s</td> <td>28 <math>\mu</math>s</td> <td>Value used for "Fast" VRMs</td> </tr> <tr> <td>10b</td> <td>34 <math>\mu</math>s</td> <td>40 <math>\mu</math>s</td> <td>Value used for "Fast" VRMs</td> </tr> <tr> <td>11b</td> <td></td> <td></td> <td>Reserved</td> </tr> </tbody> </table>	Bits	t266 <sub>min</sub>	t266 <sub>max</sub>	Comment	00b	95 $\mu$ s	101 $\mu$ s	Default	01b	22 $\mu$ s	28 $\mu$ s	Value used for "Fast" VRMs	10b	34 $\mu$ s	40 $\mu$ s	Value used for "Fast" VRMs	11b			Reserved
Bits	t266 <sub>min</sub>	t266 <sub>max</sub>	Comment																		
00b	95 $\mu$ s	101 $\mu$ s	Default																		
01b	22 $\mu$ s	28 $\mu$ s	Value used for "Fast" VRMs																		
10b	34 $\mu$ s	40 $\mu$ s	Value used for "Fast" VRMs																		
11b			Reserved																		
1:0	<p><b>DPSLP-TO-SLP</b> — R/W. This field selects the DPSLP# deassertion to CPU_SLP# deassertion time (t270). Normally this value is determined by the CPU_PLL_LOCK_TIME field in the GEN_PMCON_2 register. When this field is non-zero, then the values in this register have higher priority. It is software's responsibility to program these fields in a consistent manner.</p> <table> <thead> <tr> <th>Bits</th> <th>t270</th> </tr> </thead> <tbody> <tr> <td>00b</td> <td>Use value is CPU_PLL_LOCK_TIME field (default is 30 <math>\mu</math>s)</td> </tr> <tr> <td>01b</td> <td>20 <math>\mu</math>s</td> </tr> <tr> <td>10b</td> <td>15 <math>\mu</math>s</td> </tr> <tr> <td>11b</td> <td>10 <math>\mu</math>s</td> </tr> </tbody> </table>	Bits	t270	00b	Use value is CPU_PLL_LOCK_TIME field (default is 30 $\mu$ s)	01b	20 $\mu$ s	10b	15 $\mu$ s	11b	10 $\mu$ s										
Bits	t270																				
00b	Use value is CPU_PLL_LOCK_TIME field (default is 30 $\mu$ s)																				
01b	20 $\mu$ s																				
10b	15 $\mu$ s																				
11b	10 $\mu$ s																				



### 9.8.1.7 BM\_BREAK\_EN Register (PM—D31:F0) (Mobile Only)

Offset Address:	ABh	Attribute:	R/W
Default Value:	00h	Size:	8-bit
Lockable:	No	Usage:	ACPI, Legacy
Power Well:	Core		

Bit	Description
7	<b>IDE_BREAK_EN</b> — R/W. 0 = Parallel IDE or Serial ATA traffic will not act as a break event. 1 = Parallel IDE or Serial ATA traffic acts as a break event, even if the BM_STS-ZERO_EN and POPUP_EN bits are set. Parallel IDE or Serial ATA master activity will cause BM_STS to be set and will cause a break from C3/C4.
6	<b>PCIE_BREAK_EN</b> — R/W. 0 = PCI Express* traffic will not act as a break event. 1 = PCI Express traffic acts as a break event, even if the BM_STS-ZERO_EN and POPUP_EN bits are set. PCI Express master activity will cause BM_STS to be set and will cause a break from C3/C4.
5	<b>PCI_BREAK_EN</b> — R/W. 0 = PCI traffic will not act as a break event. 1 = PCI traffic acts as a break event, even if the BM_STS-ZERO_EN and POPUP_EN bits are set. PCI master activity will cause BM_STS to be set and will cause a break from C3/C4.
4:3	Reserved
2	<b>EHCI_BREAK_EN</b> — R/W. 0 = EHCI traffic will not act as a break event. 1 = EHCI traffic acts as a break event, even if the BM_STS-ZERO_EN and POPUP_EN bits are set. EHCI master activity will cause BM_STS to be set and will cause a break from C3/C4.
1	<b>UHCI_BREAK_EN</b> — R/W. 0 = UHCI traffic will not act as a break event. 1 = USB traffic from any of the internal UHCIs acts as a break event, even if the BM_STS-ZERO_EN and POPUP_EN bits are set. UHCI master activity will cause BM_STS to be set and will cause a break from C3/C4.
0	<b>AZ_BREAK_EN</b> — R/W. 0 = Intel® High Definition Audio traffic will not act as a break event. 1 = Intel High Definition Audio traffic acts as a break event, even if the BM_STS-ZERO_EN and POPUP_EN bits are set. Intel High Definition Audio master activity will cause BM_STS to be set and will cause a break from C3/C4.



### 9.8.1.8 PMIR—Power Management Initialization Register

Offset Address: ACh Attribute: R/W, R/WL  
 Default Value: 00000000h Size: 32-bit

Bit	Description
31:21	Reserved
20	<b>CF9h Global Reset (CF9GR)</b> — R/W. When set, a CF9h write of 6h or Eh will cause a Global Reset of both the Host and the ME partitions. If this bit is cleared, a CF9h write of 6h or Eh will only reset the Host partition.
19:0	Reserved

### 9.8.1.9 QRT\_STS (PM—D31:F0): Quick Resume Technology Status Register (Intel® ICH8DH Only)

Offset Address: B0h Attribute: R/W  
 Default Value: 00h Size: 8-bit  
 Lockable: No Usage: Quick Resume Technology  
 Power Well: Resume

Bit	Description
7:5	Reserved
4	<b>QRT_SCI_NOW_STS— R/W/C:</b> This bit goes active when software writes a '1' to QRT_CNT1.SCI_NOW_CNT. It can be enabled to cause an SCI which will allow the QRT software to transition the reaction to an QRT event from an SMI# handler to an SCI handler. This bit remains set until a 1 is written to this bit position. Once a 1 is written to this bit position, the logic will “re-arm” to allow the bit to be set on the next write of '1' to SCI_NOW_CNT (Offset B1h:Bit 8).
3	<b>QRT_PB_SCI_STS — R/W/C:</b> This bit goes active when the PWRBTN# pin goes from high to low (post-debounce). It can be enabled to cause an SCI which will allow the QRT software to see when the power button has been pressed. It is a separate bit from PWRBTN_STS because the OS clears the PWRBTN_STS bit and does not provide any indication to other (i.e. QRT) software. The QRT software clears QRT_PB_SCI_STS by writing a 1 to this bit position.
2	<b>Reserved</b>
1	<b>QRT_PB_SMI_STS — R/W/C:</b> This bit goes active when the PWRBTN# pin goes from high to low (post-debounce). It can be enabled to cause an SMI# which will allow the QRT software to see when the power button has been pressed. It is a separate bit from PWRBTN_STS because the OS clears the PWRBTN_STS bit and does not provide any indication to other (i.e. QRT) software. The QRT software clears QRT_PB_SMI_STS by writing a 1 to this bit position.
0	Reserved.



**9.8.1.10 QRT\_CNT1 (PM—D31:F0): Quick Resume Technology Control 1 Register (Intel® ICH8DH Only)**

Offset Address:	B1h	Attribute:	R/W
Default Value:	0000h	Size:	16-bit
Lockable:	No	Usage:	Quick Resume Technology
Power Well:	Resume		

Bit	Description
15:10	Reserved
9	<b>SMI_OPTION_CNT</b> —R/W: When this bit is set to 1 the platform generates an SMI when an QRT event occurs (rather than generating an SCI). The SMI handler can cause the SCI by setting the SCI_NOW_CNT.
8	<b>SCI_NOW_CNT</b> —WO: When software writes a '1' to this bit, it causes QRT_SCI_NOW_STS (Offset B0:Bit 4) to assert (which can be enabled to cause an SCI). This allows the SMI handler to cause the SCI.
7	<b>PWRBTN_INT_EN</b> —R/W: When this bit is set to 1, the QRT logic is enabled to intercept the power button to cause the QRT SMI or SCI, and not immediately setting the PWRBTN_STS bit. The QRT software will later set the PWRBTN_STS bit by setting the PWRBTN_EVNT bit. <b>NOTE:</b> This bit is effective only in S0.
6	<b>PWRBTN_EVNT</b> —WO: When this bit is set to 1 by software, the PWRBTN_STS bit is set to 1. This allows software to communicate PWR_BTN event to OS. <b>NOTES:</b> 1. Power Button override still possible 2. Software does not need to clear this bit, as it is treated as an event
5:4	<b>QRT_STATE1_CNT[1:0]</b> —R/W: These bits controls the QRT_STATE1 pin. The QRT_STATE[1:0] pins can be used to control a multi color LED to indicate the platform power states to user. If QRT_LED_OWN is 0 then these bits have no impact. 00 = Low 01 = High 10 = Blinking. Note that the blink rate is ~ 1 Hz 11 = Reserved. Software must not set this combination
3:2	<b>QRT_STATE0_CNT[1:0]</b> —R/W: These bits controls the QRT_STATE0 pin. The QRT_STATE[1:0] pins can be used to control a multi-color LED to indicate the platform power states to user. If QRT_LED_OWN is 0 then these bits have no impact. 00 = Low 01 = High 10 = Blinking. Note that the blink rate is ~ 1 Hz 11 = Reserved. Software must not set this combination
1	<b>QRT_LED_OWN</b> —R/W: Software sets this bit to 1 to configure the multiplexed pins to be QRT_STATE[1:0] rather than GPIO[28:27].
0	Reserved



### 9.8.1.11 QRT\_CNT2 (PM—D31:F0): Quick Resume Technology Control 2 Register (Intel® ICH8DH Only)

Offset Address:	B3h	Attribute:	R/W
Default Value:	00h	Size:	8-bit
Lockable:	No	Usage:	Quick Resume Technology
Power Well:	RTC		

Bit	Description
7:1	Reserved
0	<p><b>QRT_EN</b>—R/W: This bit enables Quick Resume Technology            0 = QRT Disabled            1 = QRT Enabled</p> <p>When this bit is 0, the R/W bits of QRT Control Registers (QRT_CNT1, EL_CNT2) scratchpad with no effect on hardware functions. Also, WO bits have no effect on hardware functions.</p> <p>BIOS software is expected to set this bit after booting. Default value for this bit is 0.</p>

### 9.8.1.12 GPIO\_ROUT—GPIO Routing Control Register (PM—D31:F0)

Offset Address:	B8h – BBh	Attribute:	R/W
Default Value:	00000000h	Size:	32-bit
Lockable:	No	Power Well:	Resume

Bit	Description
31:30	<p><b>GPIO15 Route</b> — R/W. See bits 1:0 for description.</p> <p>Same pattern for GPIO14 through GPIO3</p>
5:4	<b>GPIO2 Route</b> — R/W. See bits 1:0 for description.
3:2	<b>GPIO1 Route</b> — R/W. See bits 1:0 for description.
1:0	<p><b>GPIO0 Route</b> — R/W. GPIO[15:0] can be routed to cause an SMI or SCI when the GPIO[n]_STS bit is set. If the GPIO0 is not set to an input, this field has no effect.</p> <p>If the system is in an S1–S5 state and if the GPE0_EN bit is also set, then the GPIO can cause a Wake event, even if the GPIO is NOT routed to cause an SMI# or SCI.</p> <p>00 = No effect.            01 = SMI# (if corresponding ALT_GPI_SMI_EN bit is also set)            10 = SCI (if corresponding GPE0_EN bit is also set)            11 = Reserved</p>

**Note:** GPIOs that are not implemented will not have the corresponding bits implemented in this register.



## 9.8.2 APM I/O Decode

Table 114 shows the I/O registers associated with APM support. This register space is enabled in the PCI Device 31: Function 0 space (APMDEC\_EN), and cannot be moved (fixed I/O location).

Table 114. APM Register Map

Address	Mnemonic	Register Name	Default	Type
B2h	APM_CNT	Advanced Power Management Control Port	00h	R/W
B3h	APM_STS	Advanced Power Management Status Port	00h	R/W

### 9.8.2.1 APM\_CNT—Advanced Power Management Control Port Register

I/O Address:	B2h	Attribute:	R/W
Default Value:	00h	Size:	8-bit
Lockable:	No	Usage:	Legacy Only
Power Well:	Core		

Bit	Description
7:0	Used to pass an APM command between the OS and the SMI handler. Writes to this port not only store data in the APMC register, but also generates an SMI# when the APMC_EN bit is set.

### 9.8.2.2 APM\_STS—Advanced Power Management Status Port Register

I/O Address:	B3h	Attribute:	R/W
Default Value:	00h	Size:	8-bit
Lockable:	No	Usage:	Legacy Only
Power Well:	Core		

Bit	Description
7:0	Used to pass data between the OS and the SMI handler. Basically, this is a scratchpad register and is not affected by any other register or function (other than a PCI reset).



### 9.8.3 Power Management I/O Registers

Table 115 shows the registers associated with ACPI and Legacy power management support. These registers are enabled in the PCI Device 31: Function 0 space (PM\_IO\_EN), and can be moved to any I/O location (128-byte aligned). The registers are defined to support the ACPI 2.0 specification, and use the same bit names.

**Note:** All reserved bits and registers will always return 0 when read, and will have no effect when written.

**Table 115. ACPI and Legacy I/O Register Map (Sheet 1 of 2)**

PMBASE + Offset	Mnemonic	Register Name	ACPI Pointer	Default	Type
00h–01h	PM1_STS	PM1 Status	PM1a_EVT_BLK	0000h	R/WC
02h–03h	PM1_EN	PM1 Enable	PM1a_EVT_BLK+2	0000h	R/W
04h–07h	PM1_CNT	PM1 Control	PM1a_CNT_BLK	00000000h	R/W, WO
08h–0Bh	PM1_TMR	PM1 Timer	PMTMR_BLK	xx000000h	RO
0Ch–0Fh	—	Reserved	—	—	—
10hh–13h	PROC_CNT	Processor Control	P_BLK	00000000h	R/W, RO, WO
14h	LV2	Level 2 (Mobile Only)	P_BLK+4	00h	RO
15h–16h	—	Reserved (Desktop Only)	—	—	—
15h	LV3	Level 3 (Mobile Only)	P_BLK+5	00h	RO
16h	LV4	Level 4 (Mobile Only)	P_BLK+6	00h	RO
17h–18h	—	Reserved (Desktop Only)	—	—	—
17h	LV5	Level 5 (Mobile Only)	P_BLK+7	00h	RO
18h	LV6	Level 6 (Mobile Only)	P_BLK+8	00h	RO
19h	—	Reserved	—	—	—
20h	—	Reserved (Desktop Only)	—	—	—
20h	PM2_CNT	PM2 Control (Mobile Only)	PM2a_CNT_BLK	00h	R/W
28h–2Bh	GPE0_STS	General Purpose Event 0 Status	GPE0_BLK	00000000h	R/WC
2Ch–2Fh	GPE0_EN	General Purpose Event 0 Enables	GPE0_BLK+4	00000000h	R/W
30h–33h	SMI_EN	SMI# Control and Enable	—	00000000h	R/W, WO, R/W (special)
34h–37h	SMI_STS	SMI Status	—	00000000h	R/WC, RO
38h–39h	ALT_GP_SMI_EN	Alternate GPI SMI Enable	—	0000h	R/W
3Ah–3Bh	ALT_GP_SMI_STS	Alternate GPI SMI Status	—	0000h	R/WC
3Dh–41h	—	Reserved	—	—	—
42h	GPE_CNTL	General Purpose Event Control	—	00h	RO, R/W
43h	—	Reserved	—	—	—
44h–45h	DEVACT_STS	Device Activity Status	—	0000h	R/WC
46h–4Fh	—	Reserved	—	—	—
50h	—	Reserved (Desktop Only)	—	—	—
50h	SS_CNT	Intel SpeedStep® Technology Control (Mobile Only)	—	01h	R/W (special)
51h–53h	—	Reserved	—	—	—



Table 115. ACPI and Legacy I/O Register Map (Sheet 2 of 2)

PMBASE + Offset	Mnemonic	Register Name	ACPI Pointer	Default	Type
54h–5Bh	—	Reserved (Desktop Only)	—	—	—
54h–57h	C3_RES	C3-Residency Register (Mobile Only)	—	00000000h	RO, R/W
58h–5Bh	C5_RES	C5-Residency Register (Mobile Only)	—	00000000h	RO, R/W
5Ch–5Fh	—	Reserved	—	—	—
60h–7Fh	—	Reserved for TCO	—	—	—





### 9.8.3.1 PM1\_STS—Power Management 1 Status Register

I/O Address:	PMBASE + 00h (ACPI PM1a_EVT_BLK)	Attribute:	R/WC
Default Value:	0000h	Size:	16-bit
Lockable:	No	Usage:	ACPI or Legacy
Power Well:	Bits 0–7: Core, Bits 8–15: Resume, except Bit 11 in RTC		

If bit 10 or 8 in this register is set, and the corresponding \_EN bit is set in the PM1\_EN register, then the ICH8 will generate a Wake Event. Once back in an S0 state (or if already in an S0 state when the event occurs), the ICH8 will also generate an SCI if the SCI\_EN bit is set, or an SMI# if the SCI\_EN bit is not set.

**Note:** Bit 5 does not cause an SMI# or a wake event. Bit 0 does not cause a wake event but can cause an SMI# or SCI.

Bit	Description
15	<p><b>Wake Status (WAK_STS)</b> — R/WC. This bit is not affected by hard resets caused by a CF9 write, but is reset by RSMRST#.</p> <p>0 = Software clears this bit by writing a 1 to it. 1 = Set by hardware when the system is in one of the sleep states (via the SLP_EN bit) and an enabled wake event occurs. Upon setting this bit, the ICH8 will transition the system to the ON state.</p> <p>If the AFTERG3_EN bit is not set and a power failure (such as removed batteries) occurs without the SLP_EN bit set, the system will return to an S0 state when power returns, and the WAK_STS bit will not be set.</p> <p>If the AFTERG3_EN bit is set and a power failure occurs without the SLP_EN bit having been set, the system will go into an S5 state when power returns, and a subsequent wake event will cause the WAK_STS bit to be set. Note that any subsequent wake event would have to be caused by either a Power Button press, or an enabled wake event that was preserved through the power failure (enable bit in the RTC well).</p>
14	<p><b>PCI Express Wake Status (PCIEXPWAK_STS)</b> — R/WC.</p> <p>0 = Software clears this bit by writing a 1 to it. If the WAKE# pin is still active during the write or the PME message received indication has not been cleared in the root port, then the bit will remain active (i.e. all inputs to this bit are level-sensitive).</p> <p>1 = This bit is set by hardware to indicate that the system woke due to a PCI Express wakeup event. This wakeup event can be caused by the PCI Express WAKE# pin being active or receipt of a PCI Express PME message at a root port. This bit is set only when one of these events causes the system to transition from a non-S0 system power state to the S0 system power state. This bit is set independent of the state of the PCIEXP_WAKE_DIS bit.</p> <p>Note: This bit does not itself cause a wake event or prevent entry to a sleeping state. Thus if the bit is 1 and the system is put into a sleeping state, the system will not automatically wake.</p>
13:12	Reserved



Bit	Description
11	<p><b>Power Button Override Status (PRBTNOR_STS)</b> — R/WC.</p> <p>0 = Software clears this bit by writing a 1 to it.            1 = This bit is set any time a Power Button Override occurs (i.e., the power button is pressed for at least 4 consecutive seconds), or due to the corresponding bit in the SMBus slave message. The power button override causes an unconditional transition to the S5 state, as well as sets the AFTERG# bit. The BIOS or SCI handler clears this bit by writing a 1 to it. This bit is not affected by hard resets via CF9h writes, and is not reset by RSMRST#. Thus, this bit is preserved through power failures. Note that if this bit is still asserted when the global SCI_EN is set then an SCI will be generated.</p>
10	<p><b>RTC Status (RTC_STS)</b> — R/WC. This bit is not affected by hard resets caused by a CF9 write, but is reset by RSMRST#.</p> <p>0 = Software clears this bit by writing a 1 to it.            1 = Set by hardware when the RTC generates an alarm (assertion of the IRQ8# signal). Additionally if the RTC_EN bit (PMBASE + 02h, bit 10) is set, the setting of the RTC_STS bit will generate a wake event.</p>
9	<p><b>ME_STS</b>: This bit is set when the ME generates a Non-Maskable wake event, and is not affected by any other enable bit. When this bit is set, the Host Power Management logic wakes to S0.</p> <p>This bit is only set by hardware and can only be reset by writing a one to this bit position. This bit is not affected by hard resets caused by a CF9 write, but is reset by RSMRST#.</p>
8	<p><b>Power Button Status (PWRBTN_STS)</b> — R/WC. This bit is not affected by hard resets caused by a CF9 write.</p> <p>0 = If the PWRBTN# signal is held low for more than 4 seconds, the hardware clears the PWRBTN_STS bit, sets the PWRBTNOR_STS bit, and the system transitions to the S5 state with only PWRBTN# enabled as a wake event.</p> <p>This bit can be cleared by software by writing a one to the bit position.            1 = This bit is set by hardware when the PWRBTN# signal is asserted Low, independent of any other enable bit.</p> <p>In the S0 state, while PWRBTN_EN and PWRBTN_STS are both set, an SCI (or SMI# if SCI_EN is not set) will be generated.</p> <p>In any sleeping state S1–S5, while PWRBTN_EN (PMBASE + 02h, bit 8) and PWRBTN_STS are both set, a wake event is generated.</p> <p><b>NOTE:</b> If the PWRBTN_STS bit is cleared by software while the PWRBTN# signal is self asserted, this will not cause the PWRBN_STS bit to be set. The PWRBTN# signal must go inactive and active again to set the PWRBTN_STS bit.</p>
7:6	Reserved
5	<p><b>Global Status (GBL_STS)</b> — R/WC.</p> <p>0 = The SCI handler should then clear this bit by writing a 1 to the bit location.            1 = Set when an SCI is generated due to BIOS wanting the attention of the SCI handler. BIOS has a corresponding bit, BIOS_RLS, which will cause an SCI and set this bit.</p>
4 (Desktop Only)	Reserved



Bit	Description
4 (Mobile Only)	<p><b>Bus Master Status (BM_STS)</b> — R/WC. This bit will not cause a wake event, SCI or SMI#.</p> <p>0 = Software clears this bit by writing a 1 to it.</p> <p>1 = Set by the ICH8 when a bus master requests access to main memory. Bus master activity is detected by any of the PCI Requests being active, any internal bus master request being active, the BMBUSY# signal being active, or REQ-C2 message received while in C3 or C4 state.</p> <p><b>NOTES:</b></p> <ol style="list-style-type: none"> <li>If the BM_STS_ZERO_EN bit is set, then this bit will generally report as a 0. LPC DMA and bus master activity will always set the BM_STS bit, even if the BM_STS_ZERO_EN bit is set.</li> </ol>
3:1	Reserved
0	<p><b>Timer Overflow Status (TMROF_STS)</b> — R/WC.</p> <p>0 = The SCI or SMI# handler clears this bit by writing a 1 to the bit location.</p> <p>1 = This bit gets set any time bit 22 of the 24-bit timer goes high (bits are numbered from 0 to 23). This will occur every 2.3435 seconds. When the TMROF_EN bit (PMBASE + 02h, bit 0) is set, then the setting of the TMROF_STS bit will additionally generate an SCI or SMI# (depending on the SCI_EN).</p>



### 9.8.3.2 PM1\_EN—Power Management 1 Enable Register

I/O Address: PMBASE + 02h  
 (ACPI PM1a\_EVT\_BLK + 2) Attribute: R/W  
 Default Value: 0000h Size: 16-bit  
 Lockable: No Usage: ACPI or Legacy  
 Power Well: Bits 0–7: Core,  
 Bits 8–9, 11–15: Resume,  
 Bit 10: RTC

Bit	Description												
15	Reserved												
14	<b>PCI Express* Wake Disable (PCIEXPWAK_DIS)</b> — R/W. Modification of this bit has no impact on the value of the PCIEXP_WAKE_STS bit. 0 = Inputs to the PCIEXP_WAKE_STS bit in the PM1 Status register enabled to wake the system. 1 = Inputs to the PCIEXP_WAKE_STS bit in the PM1 Status register disabled from waking the system												
13:11	Reserved												
10	<b>RTC Event Enable (RTC_EN)</b> — R/W. This bit is in the RTC well to allow an RTC event to wake after a power failure. This bit is not cleared by any reset other than RTCRST# or a Power Button Override event. 0 = No SCI (or SMI#) or wake event is generated then RTC_STS (PMBASE + 00h, bit 10) goes active. 1 = An SCI (or SMI#) or wake event will occur when this bit is set and the RTC_STS bit goes active.												
9	Reserved.												
8	<b>Power Button Enable (PWRBTN_EN)</b> — R/W. This bit is used to enable the setting of the PWRBTN_STS bit to generate a power management event (SMI#, SCI). PWRBTN_EN has no effect on the PWRBTN_STS bit (PMBASE + 00h, bit 8) being set by the assertion of the power button. The Power Button is always enabled as a Wake event. 0 = Disable. 1 = Enable.												
7:6	Reserved.												
5	<b>Global Enable (GBL_EN)</b> — R/W. When both the GBL_EN and the GBL_STS bit (PMBASE + 00h, bit 5) are set, an SCI is raised. 0 = Disable. 1 = Enable SCI on GBL_STS going active.												
4:1	Reserved.												
0	<b>Timer Overflow Interrupt Enable (TMROF_EN)</b> — R/W. Works in conjunction with the SCI_EN bit (PMBASE + 04h, bit 0) as described below: <table border="1" style="margin-left: 20px;"> <thead> <tr> <th>TMROF_EN</th> <th>SCI_EN</th> <th>Effect when TMROF_STS is set</th> </tr> </thead> <tbody> <tr> <td>0</td> <td>X</td> <td>No SMI# or SCI</td> </tr> <tr> <td>1</td> <td>0</td> <td>SMI#</td> </tr> <tr> <td>1</td> <td>1</td> <td>SCI</td> </tr> </tbody> </table>	TMROF_EN	SCI_EN	Effect when TMROF_STS is set	0	X	No SMI# or SCI	1	0	SMI#	1	1	SCI
TMROF_EN	SCI_EN	Effect when TMROF_STS is set											
0	X	No SMI# or SCI											
1	0	SMI#											
1	1	SCI											



### 9.8.3.3 PM1\_CNT—Power Management 1 Control

I/O Address:	PMBASE + 04h (ACPI PM1a_CNT_BLK)	Attribute:	R/W, WO
Default Value:	00000000h	Size:	32-bit
Lockable:	No	Usage:	ACPI or Legacy
Power Well:	Bits 0–7: Core, Bits 8–12: RTC, Bits 13–15: Resume		

Bit	Description																		
31:14	Reserved.																		
13	<b>Sleep Enable (SLP_EN)</b> — WO. Setting this bit causes the system to sequence into the Sleep state defined by the SLP_TYP field.																		
12:10	<p><b>Sleep Type (SLP_TYP)</b> — R/W. This 3-bit field defines the type of Sleep the system should enter when the SLP_EN bit is set to 1. These bits are only reset by RTCRST#.</p> <table> <thead> <tr> <th>Code</th> <th>Master Interrupt</th> </tr> </thead> <tbody> <tr> <td>000b</td> <td>ON: Typically maps to S0 state.</td> </tr> <tr> <td>001b</td> <td>Asserts STPCLK#. Puts processor in Stop-Grant state. Optional to assert CPUSLP# to put processor in sleep state: Typically maps to S1 state.</td> </tr> <tr> <td>010b</td> <td>Reserved</td> </tr> <tr> <td>011b</td> <td>Reserved</td> </tr> <tr> <td>100b</td> <td>Reserved</td> </tr> <tr> <td>101b</td> <td>Suspend-To-RAM. Assert SLP_S3#: Typically maps to S3 state.</td> </tr> <tr> <td>110b</td> <td>Suspend-To-Disk. Assert SLP_S3#, and SLP_S4#: Typically maps to S4 state.</td> </tr> <tr> <td>111b</td> <td>Soft Off. Assert SLP_S3#, SLP_S4#, and SLP_S5#: Typically maps to S5 state.</td> </tr> </tbody> </table>	Code	Master Interrupt	000b	ON: Typically maps to S0 state.	001b	Asserts STPCLK#. Puts processor in Stop-Grant state. Optional to assert CPUSLP# to put processor in sleep state: Typically maps to S1 state.	010b	Reserved	011b	Reserved	100b	Reserved	101b	Suspend-To-RAM. Assert SLP_S3#: Typically maps to S3 state.	110b	Suspend-To-Disk. Assert SLP_S3#, and SLP_S4#: Typically maps to S4 state.	111b	Soft Off. Assert SLP_S3#, SLP_S4#, and SLP_S5#: Typically maps to S5 state.
Code	Master Interrupt																		
000b	ON: Typically maps to S0 state.																		
001b	Asserts STPCLK#. Puts processor in Stop-Grant state. Optional to assert CPUSLP# to put processor in sleep state: Typically maps to S1 state.																		
010b	Reserved																		
011b	Reserved																		
100b	Reserved																		
101b	Suspend-To-RAM. Assert SLP_S3#: Typically maps to S3 state.																		
110b	Suspend-To-Disk. Assert SLP_S3#, and SLP_S4#: Typically maps to S4 state.																		
111b	Soft Off. Assert SLP_S3#, SLP_S4#, and SLP_S5#: Typically maps to S5 state.																		
9:3	Reserved.																		
2	<p><b>Global Release (GBL_RLS)</b> — WO.</p> <p>0 = This bit always reads as 0.</p> <p>1 = ACPI software writes a 1 to this bit to raise an event to the BIOS. BIOS software has a corresponding enable and status bits to control its ability to receive ACPI events.</p>																		
1 (Desktop Only)	Reserved																		
1 (Mobile Only)	<p><b>Bus Master Reload (BM_RLD)</b> — R/W. This bit is treated as a scratchpad bit. This bit is reset to 0 by PLTRST#</p> <p>0 = Bus master requests will not cause a break from the C3 state.</p> <p>1 = Enable Bus Master requests (internal, external or BMBUSY#) to cause a break from the C3 state.</p> <p>If software fails to set this bit before going to C3 state, ICH8 will still return to a snooperable state from C3 or C4 states due to bus master activity.</p>																		
0	<p><b>SCI Enable (SCI_EN)</b> — R/W. Selects the SCI interrupt or the SMI# interrupt for various events including the bits in the PM1_STS register (bit 10, 8, 0), and bits in GPE0_STS.</p> <p>0 = These events will generate an SMI#.</p> <p>1 = These events will generate an SCI.</p>																		



### 9.8.3.4 PM1\_TMR—Power Management 1 Timer Register

I/O Address: PMBASE + 08h  
(ACPI PMTMR\_BLK)

Attribute: RO

Default Value: xx000000h Size: 32-bit

Lockable: No Usage: ACPI

Power Well: Core

Bit	Description
31:24	Reserved
23:0	<p><b>Timer Value (TMR_VAL)</b> — RO. Returns the running count of the PM timer. This counter runs off a 3.579545 MHz clock (14.31818 MHz divided by 4). It is reset to 0 during a PCI reset, and then continues counting as long as the system is in the S0 state. After an S1 state, the counter will not be reset (it will continue counting from the last value in S0 state).</p> <p>Anytime bit 22 of the timer goes HIGH to LOW (bits referenced from 0 to 23), the TMROF_STS bit (PMBASE + 00h, bit 0) is set. The High-to-Low transition will occur every 2.3435 seconds. If the TMROF_EN bit (PMBASE + 02h, bit 0) is set, an SCI interrupt is also generated.</p>

### 9.8.3.5 PROC\_CNT—Processor Control Register

I/O Address: PMBASE + 10h  
(ACPI P\_BLK)

Attribute: R/W, RO, WO

Default Value: 00000000h Size: 32-bit

Lockable: No (bits 7:5 are write once) Usage: ACPI or Legacy

Power Well: Core

Bit	Description
31:18	Reserved
17	<p><b>Throttle Status (THTL_STS)</b> — RO.</p> <p>0 = No clock throttling is occurring (maximum processor performance).</p> <p>1 = Indicates that the clock state machine is throttling the processor performance. This could be due to the THT_EN bit or the FORCE_THTL bit being set.</p>
16:9	Reserved
8	<p><b>Force Thermal Throttling (FORCE_THTL)</b> — R/W. Software can set this bit to force the thermal throttling function.</p> <p>0 = No forced throttling.</p> <p>1 = Throttling at the duty cycle specified in THRM_DTY starts immediately, and no SMI# is generated.</p>



Bit	Description																											
7:5	<p><b>THRM_DTY</b> — WO. This write-once field determines the duty cycle of the throttling when the FORCE_THTL bit is set. The duty cycle indicates the approximate percentage of time the STPCLK# signal is asserted while in the throttle mode. The STPCLK# throttle period is 1024 PCICLKs. Note that the throttling only occurs if the system is in the C0 state. For mobile components, if in the C2, C3, or C4 state, no throttling occurs. Once the THRM_DTY field is written, any subsequent writes will have no effect until PLTRST# goes active.</p> <table border="1"> <thead> <tr> <th>THRM_DTY</th> <th>Throttle Mode</th> <th>PCI Clocks</th> </tr> </thead> <tbody> <tr> <td>000b</td> <td>50% (Default)</td> <td>512</td> </tr> <tr> <td>001b</td> <td>87.5%</td> <td>896</td> </tr> <tr> <td>010b</td> <td>75.0%</td> <td>768</td> </tr> <tr> <td>011b</td> <td>62.5%</td> <td>640</td> </tr> <tr> <td>100b</td> <td>50%</td> <td>512</td> </tr> <tr> <td>101b</td> <td>37.5%</td> <td>384</td> </tr> <tr> <td>110b</td> <td>25%</td> <td>256</td> </tr> <tr> <td>111b</td> <td>12.5%</td> <td>128</td> </tr> </tbody> </table>	THRM_DTY	Throttle Mode	PCI Clocks	000b	50% (Default)	512	001b	87.5%	896	010b	75.0%	768	011b	62.5%	640	100b	50%	512	101b	37.5%	384	110b	25%	256	111b	12.5%	128
THRM_DTY	Throttle Mode	PCI Clocks																										
000b	50% (Default)	512																										
001b	87.5%	896																										
010b	75.0%	768																										
011b	62.5%	640																										
100b	50%	512																										
101b	37.5%	384																										
110b	25%	256																										
111b	12.5%	128																										
4	<p><b>THTL_EN</b> — R/W. When set and the system is in a C0 state, it enables a processor-controlled STPCLK# throttling. The duty cycle is selected in the THTL_DTY field. 0 = Disable 1 = Enable</p>																											
3:1	<p><b>THTL_DTY</b> — R/W. This field determines the duty cycle of the throttling when the THTL_EN bit is set. The duty cycle indicates the approximate percentage of time the STPCLK# signal is asserted (low) while in the throttle mode. The STPCLK# throttle period is 1024 PCICLKs.</p> <table border="1"> <thead> <tr> <th>THTL_DTY</th> <th>Throttle Mode</th> <th>PCI Clocks</th> </tr> </thead> <tbody> <tr> <td>000b</td> <td>50% (Default)</td> <td>512</td> </tr> <tr> <td>001b</td> <td>87.5%</td> <td>896</td> </tr> <tr> <td>010b</td> <td>75.0%</td> <td>768</td> </tr> <tr> <td>011b</td> <td>62.5%</td> <td>640</td> </tr> <tr> <td>100b</td> <td>50%</td> <td>512</td> </tr> <tr> <td>101b</td> <td>37.5%</td> <td>384</td> </tr> <tr> <td>110b</td> <td>25%</td> <td>256</td> </tr> <tr> <td>111b</td> <td>12.5%</td> <td>128</td> </tr> </tbody> </table>	THTL_DTY	Throttle Mode	PCI Clocks	000b	50% (Default)	512	001b	87.5%	896	010b	75.0%	768	011b	62.5%	640	100b	50%	512	101b	37.5%	384	110b	25%	256	111b	12.5%	128
THTL_DTY	Throttle Mode	PCI Clocks																										
000b	50% (Default)	512																										
001b	87.5%	896																										
010b	75.0%	768																										
011b	62.5%	640																										
100b	50%	512																										
101b	37.5%	384																										
110b	25%	256																										
111b	12.5%	128																										
0	Reserved																											



### 9.8.3.6 LV2 — Level 2 Register (Mobile Only)

I/O Address: PMBASE + 14h  
(ACPI P\_BLK+4) Attribute: RO  
 Default Value: 00h Size: 8-bit  
 Lockable: No Usage: ACPI or Legacy  
 Power Well: Core

Bit	Description
7:0	Reads to this register return all 0s, writes to this register have no effect. Reads to this register generate a “enter a level 2 power state” (C2) to the clock control logic. This will cause the STPCLK# signal to go active, and stay active until a break event occurs. Throttling (due either to THTL_EN or FORCE_THTL) will be ignored.

**NOTE:** This register should not be used by Intel® iA64 processors or systems with more than 1 logical processor, unless appropriate semaphoring software has been put in place to ensure that all threads/processors are ready for the C2 state when the read to this register occurs

### 9.8.3.7 LV3—Level 3 Register (Mobile Only)

I/O Address: PMBASE + 15h (ACPI P\_BLK + 5) Attribute: RO  
 Default Value: 00h Size: 8-bit  
 Lockable: No Usage: ACPI or Legacy  
 Power Well: Core

Bit	Description
7:0	Reads to this register return all 0s, writes to this register have no effect. Reads to this register generate a “enter a C3 power state” to the clock control logic. The C3 state persists until a break event occurs.

**NOTE:** If the C4onC3\_EN bit is set, reads this register will initiate a LVL4 transition rather than a LVL3 transition. In the event that software attempts to simultaneously read the LVL2 and LVL3 registers (which is invalid), the ICH8 will ignore the LVL3 read, and only perform a C2 transition.

**NOTE:** This register should not be used by iA64 processors or systems with more than 1 logical processor, unless appropriate semaphoring software has been put in place to ensure that all threads/processors are ready for the C3 state when the read to this register occurs.

### 9.8.3.8 LV4—Level 4 Register (Mobile Only)

I/O Address: PMBASE + 16h (ACPI P\_BLK + 6) Attribute: RO  
 Default Value: 00h Size: 8-bit  
 Lockable: No Usage: ACPI or Legacy  
 Power Well: Core

Bit	Description
7:0	Reads to this register return all 0s, writes to this register have no effect. Reads to this register generate a “enter a C4 power state” to the clock control logic. The C4 state persists until a break event occurs.

**NOTE:** This register should not be used by iA64 processors or systems with more than 1 logical processor, unless appropriate semaphoring software has been put in place to ensure that all threads/processors are ready for the C4 state when the read to this register occurs.





### 9.8.3.9 LV5—Level 5 Register (Mobile Only)

I/O Address: PMBASE + 17h (ACPI P\_BLK + 7)  
 Attribute: RO  
 Default Value: 00h  
 Size: 8-bit  
 Lockable: No  
 Usage: ACPI or Legacy  
 Power Well: Core

Bit	Description
7:0	Reads to this register return all 0's, writes to this register have no effect. Reads to this register generate a "enter a C5 power state" to the clock control logic. The C5 state persists until a break event occurs.

**NOTE:** This register should not be used by IA-64 processors or systems with more than 1 logical processor, unless appropriate semaphoring software has been put in place to ensure that all threads/processors are ready for the C5 state when the read to this register occurs.

### 9.8.3.10 LV6—Level 6 Register (Mobile Only)

I/O Address: PMBASE + 18h (ACPI P\_BLK + 8)  
 Attribute: RO  
 Default Value: 00h  
 Size: 8-bit  
 Lockable: No  
 Usage: ACPI or Legacy  
 Power Well: Core

Bit	Description
7:0	Reads to this register return all 0's, writes to this register have no effect. Reads to this register generate a "enter a C6 power state" to the clock control logic. The C6 state persists until a break event occurs.

**NOTE:** This register should not be used by IA-64 processors or systems with more than 1 logical processor, unless appropriate semaphoring software has been put in place to ensure that all threads/processors are ready for the C6 state when the read to this register occurs.

### 9.8.3.11 PM2\_CNT—Power Management 2 Control (Mobile Only)

I/O Address: PMBASE + 20h  
 (ACPI PM2\_BLK) Attribute: R/W  
 Default Value: 00h  
 Size: 8-bit  
 Lockable: No  
 Usage: ACPI  
 Power Well: Core

Bit	Description
7:1	Reserved
0	<b>Arbiter Disable (ARB_DIS)</b> — R/W This bit is essentially just a scratchpad bit for legacy software compatibility. Software typically sets this bit to 1 prior to entering a C3 or C4 state. When a transition to a C3 or C4 state occurs, ICH8 will automatically prevent any internal or external non-Isoch bus masters from initiating any cycles up to the (G)MCH. This blocking starts immediately upon the ICH8 sending the Go-C3 message to the (G)MCH. The blocking stops when the Ack-C2 message is received. Note that this is not really blocking, in that messages (such as from PCI Express*) are just queued and held pending.



### 9.8.3.12 GPE0\_STS—General Purpose Event 0 Status Register

I/O Address:	PMBASE + 28h (ACPI GPE0_BLK)	Attribute:	R/WC
Default Value:	00000000h	Size:	32-bit
Lockable:	No	Usage:	ACPI
Power Well:	Resume		

This register is symmetrical to the General Purpose Event 0 Enable Register. Unless indicated otherwise below, if the corresponding \_EN bit is set, then when the \_STS bit get set, the ICH8 will generate a Wake Event. Once back in an S0 state (or if already in an S0 state when the event occurs), the ICH8 will also generate an SCI if the SCI\_EN bit is set, or an SMI# if the SCI\_EN bit (PMBASE + 04h, bit 0) is not set. Bits 31:16 are reset by a CF9h write; bits 15:0 are not. All are reset by RSMRST#.

Bit	Description
31:16	<p><b>GPIOn_STS</b> — R/WC.</p> <p>0 = Software clears this bit by writing a 1 to it.</p> <p>1 = These bits are set any time the corresponding GPIO is set up as an input and the corresponding GPIO signal is high (or low if the corresponding GP_INV bit is set). If the corresponding enable bit is set in the GPE0_EN register, then when the GPIO[n]_STS bit is set:</p> <ul style="list-style-type: none"> <li>• If the system is in an S1–S5 state, the event will also wake the system.</li> <li>• If the system is in an S0 state (or upon waking back to an S0 state), a SCI will be caused depending on the GPIO_ROUT bits (D31:F0:B8h, bits 31:30) for the corresponding GPI.</li> </ul> <p><b>NOTE:</b> Mapping is as follows: bit 31 corresponds to GPIO[15]... and bit 16 corresponds to GPIO[0].</p>
15	Reserved
14	<p><b>USB4_STS</b> — R/WC.</p> <p>0 = Disable.</p> <p>1 = Set by hardware and can be reset by writing a one to this bit position or a resume well reset. This bit is set when USB UHCI controller #4 needs to cause a wake. Additionally if the USB4_EN bit is set, the setting of the USB4_STS bit will generate a wake event.</p>
13	<p><b>PME_BO_STS</b> — R/WC. This bit will be set to 1 by the ICH8 when any internal device with PCI Power Management capabilities on bus 0 asserts the equivalent of the PME# signal. Additionally, if the PME_BO_EN bit is set, and the system is in an S0 state, then the setting of the PME_BO_STS bit will generate an SCI (or SMI# if SCI_EN is not set). If the PME_BO_STS bit is set, and the system is in an S1–S4 state (or S5 state due to SLP_TYP and SLP_EN), then the setting of the PME_BO_STS bit will generate a wake event, and an SCI (or SMI# if SCI_EN is not set) will be generated. If the system is in an S5 state due to power button override, then the PME_BO_STS bit will not cause a wake event or SCI.</p> <p>The default for this bit is 0. Writing a 1 to this bit position clears this bit.</p> <p><b>Note:</b> On ICH8, HD audio wake events are changed to be reported in this bit. ME “maskable” wake events are also reported in this bit.</p>
12	<p><b>USB3_STS</b> — R/WC.</p> <p>0 = Disable.</p> <p>1 = Set by hardware and can be reset by writing a one to this bit position or a resume well reset. This bit is set when USB UHCI controller #3 needs to cause a wake. Additionally if the USB3_EN bit is set, the setting of the USB3_STS bit will generate a wake event.</p>



Bit	Description
11	<p><b>PME_STS</b> — R/WC.</p> <p>0 = Software clears this bit by writing a 1 to it.</p> <p>1 = Set by hardware when the PME# signal goes active. Additionally, if the PME_EN bit is set, and the system is in an S0 state, then the setting of the PME_STS bit will generate an SCI or SMI# (if SCI_EN is not set). If the PME_EN bit is set, and the system is in an S1–S4 state (or S5 state due to setting SLP_TYP and SLP_EN), then the setting of the PME_STS bit will generate a wake event, and an SCI will be generated. If the system is in an S5 state due to power button override or a power failure, then PME_STS will not cause a wake event or SCI.</p>
10 (ICH8 Base, ICH8R, ICH8DO Only)	Reserved
10 (ICH8DH Only)	<p><b>QRT_SCI_STS</b> — R/WC: In Desktop Mode, when Quick Resume Technology feature is enabled, this bit will be set by hardware when the SCI_NOW_CNT or QRT_PB_SCI_STS bit goes high. Software clears the bit by writing a 1 to the bit position.</p> <p>In Desktop Mode, when QRT feature is disabled, this bit will be treated as Reserved.</p>
10 (Mobile Only)	<p><b>BATLOW_STS</b> — R/WC. Software clears this bit by writing a 1 to it.</p> <p>0 = BATLOW# Not asserted</p> <p>1 = Set by hardware when the BATLOW# signal is asserted.</p>
9	<p><b>PCI_EXP_STS</b> — R/WC.</p> <p>0 = Software clears this bit by writing a 1 to it.</p> <p>1 = Set by hardware to indicate that:</p> <ul style="list-style-type: none"> <li>• The PME event message was received on one or more of the PCI Express* ports</li> <li>• An Assert PMEGPE message received from the (G)MCH via DMI</li> </ul> <p><b>NOTES:</b></p> <ol style="list-style-type: none"> <li>1. The PCI WAKE# pin has no impact on this bit.</li> <li>2. If the PCI_EXP_STS bit went active due to an Assert PMEGPE message, then a Deassert PMEGPE message must be received prior to the software write in order for the bit to be cleared.</li> <li>3. If the bit is not cleared and the corresponding PCI_EXP_EN bit is set, the level-triggered SCI will remain active.</li> <li>4. A race condition exists where the PCI Express device sends another PME message because the PCI Express device was not serviced within the time when it must resend the message. This may result in a spurious interrupt, and this is comprehended and approved by the <i>PCI Express* Specification, Revision 1.0a</i>. The window for this race condition is approximately 95-105 milliseconds.</li> </ol>
8	<p><b>RI_STS</b> — R/WC.</p> <p>0 = Software clears this bit by writing a 1 to it.</p> <p>1 = Set by hardware when the RI# input signal goes active.</p>



Bit	Description
7	<p><b>SMBus Wake Status (SMB_WAK_STS)</b> — R/WC. The SMBus controller can independently cause an SMI# or SCI, so this bit does not need to do so (unlike the other bits in this register). Software clears this bit by writing a 1 to it.</p> <p>0 = Wake event Not caused by the ICH8's SMBus logic.            1 = Set by hardware to indicate that the wake event was caused by the ICH8's SMBus logic. This bit will be set by the WAKE/SMI# command type, even if the system is already awake. The SMI handler should then clear this bit.</p> <p>NOTES:</p> <ol style="list-style-type: none"> <li>1. This bit is set by the SMBus slave command 01h (Wake/SMI#) even when the system is in the S0 state. Therefore, to avoid an instant wake on subsequent transitions to sleep states, software must clear this bit after each reception of the Wake/SMI# command or just prior to entering the sleep state.</li> <li>2. If SMB_WAK_STS is set due to SMBus slave receiving a message, it will be cleared by internal logic when a THRMTRIP# event happens or a Power Button Override event. However, THRMTRIP# or Power Button Override event will not clear SMB_WAK_STS if it is set due to SMBALERT# signal going active.</li> <li>3. The SMBALERT_STS bit (D31:F3: I/O Offset 00h: Bit 5) should be cleared by software before the SMB_WAK_STS bit is cleared.</li> </ol>
6	<p><b>TCOSCI_STS</b> — R/WC. Software clears this bit by writing a 1 to it.</p> <p>0 = TOC logic or thermal sensor logic did Not cause SCI.            1 = Set by hardware when the TCO logic or thermal sensor logic causes an SCI.</p>
5	<p><b>USB5_STS</b>— R/WC. Software clears this bit by writing a 1 to it.</p> <p>0 = USB UHCI controller 5 does NOT need to cause a wake.            1 = Set by hardware when USB UHCI controller 5 needs to cause a wake. Wake event will be generated if the corresponding USB2_EN bit is set.</p>
4	<p><b>USB2_STS</b> — R/WC. Software clears this bit by writing a 1 to it.</p> <p>0 = USB UHCI controller 2 does Not need to cause a wake.            1 = Set by hardware when USB UHCI controller 2 needs to cause a wake. Wake event will be generated if the corresponding USB2_EN bit is set.</p>
3	<p><b>USB1_STS</b> — R/WC. Software clears this bit by writing a 1 to it.</p> <p>0 = USB UHCI controller 1 does Not need to cause a wake.            1 = Set by hardware when USB UHCI controller 1 needs to cause a wake. Wake event will be generated if the corresponding USB1_EN bit is set.</p>
2	<p><b>SWGPE_STS</b> — R/WC.</p> <p>The SWGPE_CTRL bit (bit 1 of GPE_CTRL reg) acts as a level input to this bit.</p>
1	<p><b>HOT_PLUG_STS</b> — R/WC.</p> <p>0 = This bit is cleared by writing a 1 to this bit position.            1 = When a PCI Express* Hot-Plug event occurs. This will cause an SCI if the HOT_PLUG_EN bit is set in the GEPO_EN register.</p>
0	<p><b>Thermal Interrupt Status (THRM_STS)</b> — R/WC. Software clears this bit by writing a 1 to it.</p> <p>0 = THRM# signal Not driven active as defined by the THRM_POL bit            1 = Set by hardware anytime the THRM# signal is driven active as defined by the THRM_POL bit. Additionally, if the THRM_EN bit is set, then the setting of the THRM_STS bit will also generate a power management event (SCI or SMI#).</p>



### 9.8.3.13 GPE0\_EN—General Purpose Event 0 Enables Register

I/O Address:	PMBASE + 2Ch (ACPI GPE0_BLK + 4)	Attribute:	R/W
Default Value:	00000000h	Size:	32-bit
Lockable:	No	Usage:	ACPI
Power Well:	Bits 0–7, 9, 12, 14–31 Resume, Bits 8, 10–11, 13 RTC		

This register is symmetrical to the General Purpose Event 0 Status Register. All the bits in this register should be cleared to 0 based on a Power Button Override or processor Thermal Trip event. The resume well bits are all cleared by RSMRST#. The RTC sell bits are cleared by RTCRST#.

Bit	Description
31:16	<b>GPIIn_EN</b> — R/W. These bits enable the corresponding GPI[n]_STS bits being set to cause a SCI, and/or wake event. These bits are cleared by RSMRST#. <b>NOTE:</b> Mapping is as follows: bit 31 corresponds to GPIO15... and bit 16 corresponds to GPIO0.
15	Reserved
14	<b>USB4_EN</b> — R/W. 0 = Disable. 1 = Enable the setting of the USB4_STS bit to generate a wake event. The USB4_STS bit is set anytime USB UHCI controller #4 signals a wake event. Break events are handled via the USB interrupt.
13	<b>PME_BO_EN</b> — R/W. 0 = Disable 1 = Enables the setting of the PME_BO_STS bit to generate a wake event and/or an SCI or SMI#. PME_BO_STS can be a wake event from the S1–S4 states, or from S5 (if entered via SLP_TYP and SLP_EN) or power failure, but not Power Button Override. This bit defaults to 0. <b>NOTE:</b> It is only cleared by Software or RTCRST#. It is not cleared by CF9h writes.
12	<b>USB3_EN</b> — R/W. 0 = Disable. 1 = Enable the setting of the USB3_STS bit to generate a wake event. The USB3_STS bit is set anytime USB UHCI controller #3 signals a wake event. Break events are handled via the USB interrupt.
11	<b>PME_EN</b> — R/W. 0 = Disable. 1 = Enables the setting of the PME_STS to generate a wake event and/or an SCI. PME# can be a wake event from the S1 – S4 state or from S5 (if entered via SLP_EN, but not power button override).
10 (Desktop Only)	<b>QRT_SCI_EN</b> — R/W. In Desktop Mode this bit enables the QRT_SCI_STS signal to cause an SCI (depending on the SCI_EN bit) when it is asserted
10 (Mobile Only)	<b>BATLOW_EN</b> — R/W. 0 = Disable. 1 = Enables the BATLOW# signal to cause an SMI# or SCI (depending on the SCI_EN bit) when it goes low. This bit does not prevent the BATLOW# signal from inhibiting the wake event.



Bit	Description
9	<b>PCI_EXP_EN</b> — R/W. 0 = Disable SCI generation upon PCI_EXP_STS bit being set. 1 = Enables ICH8 to cause an SCI when PCI_EXP_STS bit is set. This is used to allow the PCI Express* ports, including the link to the (G)MCH, to cause an SCI due to wake/PME events.
8	<b>RI_EN</b> — R/W. The value of this bit will be maintained through a G3 state and is not affected by a hard reset caused by a CF9h write. 0 = Disable. 1 = Enables the setting of the RI_STS to generate a wake event.
7	Reserved
6	<b>TCOSCI_EN</b> — R/W. 0 = Disable. 1 = Enables the setting of the TCOSCI_STS to generate an SCI.
5	<b>USB5_EN</b> — R/W. 0 = Disable. 1 = Enables the setting of the USB5_STS to generate a wake event.
4	<b>USB2_EN</b> — R/W. 0 = Disable. 1 = Enables the setting of the USB2_STS to generate a wake event.
3	<b>USB1_EN</b> — R/W. 0 = Disable. 1 = Enables the setting of the USB1_STS to generate a wake event.
2	<b>SWGPE_EN</b> — R/W. This bit allows software to control the assertion of SWGPE_STS bit. This bit This bit, when set to 1, enables the SW GPE function. If SWGPE_CTRL is written to a 1, hardware will set SWGPE_STS (acts as a level input) If SWGPE_STS, SWGPE_EN, and SCI_EN are all 1's, an SCI will be generated If SWGPE_STS = 1, SWGPE_EN = 1, SCI_EN = 0, and GBL_SMI_EN = 1 then an SMI# will be generated
1	<b>HOT_PLUG_EN</b> — R/W. 0 = Disables SCI generation upon the HOT_PLUG_STS bit being set. 1 = Enables the ICH8 to cause an SCI when the HOT_PLUG_STS bit is set. This is used to allow the PCI Express ports to cause an SCI due to hot-plug events.
0	<b>THRM_EN</b> — R/W. 0 = Disable. 1 = Active assertion of the THRM# signal (as defined by the THRM_POL bit) will set the THRM_STS bit and generate a power management event (SCI or SMI).



### 9.8.3.14 SMI\_EN—SMI Control and Enable Register

I/O Address:	PMBASE + 30h	Attribute:	R/W, R/W (special), WO
Default Value:	00000000h	Size:	32 bit
Lockable:	No	Usage:	ACPI or Legacy
Power Well:	Core		

**Note:** This register is symmetrical to the SMI status register.

Bit	Description
31:26	Reserved
25	<b>EL_SMI_EN</b> — R/W. 0 = Disable 1 = Software sets this bit to enable Energy Lake logic to cause SMI#
24:19	Reserved
18	<b>INTEL_USB2_EN</b> — R/W. 0 = Disable 1 = Enables Intel-Specific USB2 SMI logic to cause SMI#.
17	<b>LEGACY_USB2_EN</b> — R/W. 0 = Disable 1 = Enables legacy USB2 logic to cause SMI#.
16:15	Reserved
14	<b>PERIODIC_EN</b> — R/W. 0 = Disable. 1 = Enables the ICH8 to generate an SMI# when the PERIODIC_STS bit (PMBASE + 34h, bit 14) is set in the SMI_STS register (PMBASE + 34h).
13	<b>TCO_EN</b> — R/W. 0 = Disables TCO logic generating an SMI#. Note that if the NMI2SMI_EN bit is set, SMIs that are caused by re-routed NMIs will not be gated by the TCO_EN bit. Even if the TCO_EN bit is 0, NMIs will still be routed to cause SMIs. 1 = Enables the TCO logic to generate SMI#. <b>NOTE:</b> This bit cannot be written once the TCO_LOCK bit is set.
12	Reserved
11	<b>MCSMI_EN</b> Microcontroller SMI Enable ( <b>MCSMI_EN</b> ) — R/W. 0 = Disable. 1 = Enables ICH8 to trap accesses to the microcontroller range (62h or 66h) and generate an SMI#. Note that ‘trapped’ cycles will be claimed by the ICH8 on PCI, but not forwarded to LPC.
10:8	Reserved
7	<b>BIOS Release (BIOS_RLS)</b> — WO. 0 = This bit will always return 0 on reads. Writes of 0 to this bit have no effect. 1 = Enables the generation of an SCI interrupt for ACPI software when a one is written to this bit position by BIOS software. <b>NOTE:</b> GBL_STS being set will cause an SCI, even if the SCI_EN bit is not set. Software must take great care not to set the BIOS_RLS bit (which causes GBL_STS to be set) if the SCI handler is not in place.



Bit	Description
6	<p><b>Software SMI# Timer Enable (SWSMI_TMR_EN)</b> — R/W.</p> <p>0 = Disable. Clearing the SWSMI_TMR_EN bit before the timer expires will reset the timer and the SMI# will not be generated.</p> <p>1 = Starts Software SMI# Timer. When the SWSMI timer expires (the timeout period depends upon the SWSMI_RATE_SEL bit setting), SWSMI_TMR_STS is set and an SMI# is generated. SWSMI_TMR_EN stays set until cleared by software.</p>
5	<p><b>APMC_EN</b> — R/W.</p> <p>0 = Disable. Writes to the APM_CNT register will not cause an SMI#.</p> <p>1 = Enables writes to the APM_CNT register to cause an SMI#.</p>
4	<p><b>SLP_SMI_EN</b> — R/W.</p> <p>0 = Disables the generation of SMI# on SLP_EN. Note that this bit must be 0 before the software attempts to transition the system into a sleep state by writing a 1 to the SLP_EN bit.</p> <p>1 = A write of 1 to the SLP_EN bit (bit 13 in PM1_CNT register) will generate an SMI#, and the system will not transition to the sleep state based on that write to the SLP_EN bit.</p>
3	<p><b>LEGACY_USB_EN</b> — R/W.</p> <p>0 = Disable.</p> <p>1 = Enables legacy USB circuit to cause SMI#.</p>
2	<p><b>BIOS_EN</b> — R/W.</p> <p>0 = Disable.</p> <p>1 = Enables the generation of SMI# when ACPI software writes a 1 to the GBL_RLS bit (D31:F0:PMBase + 04h:bit 2). Note that if the BIOS_STS bit (D31:F0:PMBase + 34h:bit 2), which gets set when software writes 1 to GBL_RLS bit, is already a 1 at the time that BIOS_EN becomes 1, an SMI# will be generated when BIOS_EN gets set.</p>
1	<p><b>End of SMI (EOS)</b> — R/W (special). This bit controls the arbitration of the SMI signal to the processor. This bit must be set for the ICH8 to assert SMI# low to the processor after SMI# has been asserted previously.</p> <p>0 = Once the ICH8 asserts SMI# low, the EOS bit is automatically cleared.</p> <p>1 = When this bit is set to 1, SMI# signal will be deasserted for 4 PCI clocks before its assertion. In the SMI handler, the processor should clear all pending SMIs (by servicing them and then clearing their respective status bits), set the EOS bit, and exit SMM. This will allow the SMI arbiter to re-assert SMI upon detection of an SMI event and the setting of a SMI status bit.</p> <p><b>NOTE:</b> ICH8 is able to generate 1st SMI after reset even though EOS bit is not set. Subsequent SMI require EOS bit is set.</p>
0	<p><b>GBL_SMI_EN</b> — R/W.</p> <p>0 = No SMI# will be generated by ICH8. This bit is reset by a PCI reset event.</p> <p>1 = Enables the generation of SMI# in the system upon any enabled SMI event.</p> <p><b>NOTE:</b> When the SMI_LOCK bit is set, this bit cannot be changed.</p>





### 9.8.3.15 SMI\_STS—SMI Status Register

I/O Address:	PMBASE + 34h	Attribute:	RO, R/WC
Default Value:	00000000h	Size:	32-bit
Lockable:	No	Usage:	ACPI or Legacy
Power Well:	Core		

**Note:** If the corresponding \_EN bit is set when the \_STS bit is set, the ICH8 will cause an SMI# (except bits 8–10 and 12, which do not need enable bits since they are logic ORs of other registers that have enable bits). The ICH8 uses the same GPE0\_EN register (I/O address: PMBase+2Ch) to enable/disable both SMI and ACPI SCI general purpose input events. ACPI OS assumes that it owns the entire GPE0\_EN register per ACPI spec. Problems arise when some of the general-purpose inputs are enabled as SMI by BIOS, and some of the general purpose inputs are enabled for SCI. In this case ACPI OS turns off the enabled bit for any GPIx input signals that are not indicated as SCI general-purpose events at boot, and exit from sleeping states. BIOS should define a dummy control method which prevents the ACPI OS from clearing the SMI GPE0\_EN bits.

Bit	Description
31:27	Reserved
26	<b>SPI_STS</b> — RO. This bit will be set if the SPI logic is generating an SMI#. This bit is read only because the sticky status and enable bits associated with this function are located in the SPI registers.
25	<b>EL_SMI_STS</b> — RO. This bit will be set if the Energy Lake logic is generating an SMI#. Writing a 1 to this bit clears this bit to '0'.
24:22	Reserved
21	<b>MONITOR_STS</b> — RO. This bit will be set if the Trap/SMI logic has caused the SMI. This will occur when the processor or a bus master accesses an assigned register (or a sequence of accesses). See <a href="#">Section 7.1.44</a> through <a href="#">Section 7.1.47</a> for details on the specific cause of the SMI.
20	<b>PCI_EXP_SMI_STS</b> — RO. PCI Express* SMI event occurred. This could be due to a PCI Express PME event or Hot-Plug event.
19	Reserved
18	<b>INTEL_USB2_STS</b> — RO. This non-sticky read-only bit is a logical OR of each of the SMI status bits in the Intel-Specific USB2 SMI Status Register ANDed with the corresponding enable bits. This bit will not be active if the enable bits are not set. Writes to this bit will have no effect. All integrated USB2 Host Controllers are represented with this bit.
17	<b>LEGACY_USB2_STS</b> — RO. This non-sticky read-only bit is a logical OR of each of the SMI status bits in the USB2 Legacy Support Register ANDed with the corresponding enable bits. This bit will not be active if the enable bits are not set. Writes to this bit will have no effect. All integrated USB2 Host Controllers are represented with this bit.



Bit	Description
16	<p><b>SMBus SMI Status (SMBUS_SMI_STS)</b> — R/WC. Software clears this bit by writing a 1 to it.</p> <p>0 = This bit is set from the 64 kHz clock domain used by the SMBus. Software must wait at least 15.63 us after the initial assertion of this bit before clearing it.</p> <p>1 = Indicates that the SMI# was caused by:</p> <ol style="list-style-type: none"> <li>1. The SMBus Slave receiving a message that an SMI# should be caused, or</li> <li>2. The SMBALERT# signal goes active and the SMB_SMI_EN bit is set and the SMBALERT_DIS bit is cleared, or</li> <li>3. The SMBus Slave receiving a Host Notify message and the HOST_NOTIFY_INTREN and the SMB_SMI_EN bits are set, or</li> <li>4. The ICH8 detecting the SMLINK_SLAVE_SMI command while in the S0 state.</li> </ol>
15	<p><b>SERIRQ_SMI_STS</b> — RO.</p> <p>0 = SMI# was not caused by the SERIRQ decoder.</p> <p>1 = Indicates that the SMI# was caused by the SERIRQ decoder.</p> <p><b>NOTE:</b> This is not a sticky bit</p>
14	<p><b>PERIODIC_STS</b> — R/WC. Software clears this bit by writing a 1 to it.</p> <p>0 = Software clears this bit by writing a 1 to it.</p> <p>1 = This bit is set at the rate determined by the PER_SMI_SEL bits. If the PERIODIC_EN bit (PMBASE + 30h, bit 14) is also set, the ICH8 generates an SMI#.</p>
13	<p><b>TCO_STS</b> — R/WC. Software clears this bit by writing a 1 to it.</p> <p>0 = SMI# not caused by TCO logic.</p> <p>1 = Indicates the SMI# was caused by the TCO logic. Note that this is not a wake event.</p>
12	<p><b>Device Monitor Status (DEVMON_STS)</b> — RO.</p> <p>0 = SMI# not caused by Device Monitor.</p> <p>1 = Set if bit 0 of the DEVACT_STS register (PMBASE + 44h) is set. The bit is not sticky, so writes to this bit will have no effect.</p>
11	<p><b>Microcontroller SMI# Status (MCSMI_STS)</b> — R/WC. Software clears this bit by writing a 1 to it.</p> <p>0 = Indicates that there has been no access to the power management microcontroller range (62h or 66h).</p> <p>1 = Set if there has been an access to the power management microcontroller range (62h or 66h) and the Microcontroller Decode Enable #1 bit in the LPC Bridge I/O Enables configuration register is 1 (D31:F0:Offset 82h:bit 11). Note that this implementation assumes that the Microcontroller is on LPC. If this bit is set, and the MCSMI_EN bit is also set, the ICH8 will generate an SMI#.</p>
10	<p><b>GPE0_STS</b> — RO. This bit is a logical OR of the bits in the ALT_GP_SMI_STS register that are also set up to cause an SMI# (as indicated by the GPI_ROUT registers) and have the corresponding bit set in the ALT_GP_SMI_EN register. Bits that are not routed to cause an SMI# will have no effect on this bit.</p> <p>0 = SMI# was not generated by a GPI assertion.</p> <p>1 = SMI# was generated by a GPI assertion.</p>
9	<p><b>GPE0_STS</b> — RO. This bit is a logical OR of the bits 14:10, 8:2, and 0 in the GPE0_STS register (PMBASE + 28h) that also have the corresponding bit set in the GPE0_EN register (PMBASE + 2Ch).</p> <p>0 = SMI# was not generated by a GPE0 event.</p> <p>1 = SMI# was generated by a GPE0 event.</p>
8	<p><b>PM1_STS_REG</b> — RO. This is an ORs of the bits in the ACPI PM1 Status Register (offset PMBASE+00h) that can cause an SMI#.</p> <p>0 = SMI# was not generated by a PM1_STS event.</p> <p>1 = SMI# was generated by a PM1_STS event.</p>



Bit	Description
7	Reserved
6	<b>SWSMI_TMR_STS</b> — R/WC. Software clears this bit by writing a 1 to it. 0 = Software SMI# Timer has Not expired. 1 = Set by the hardware when the Software SMI# Timer expires.
5	<b>APM_STS</b> — R/WC. Software clears this bit by writing a 1 to it. 0 = No SMI# generated by write access to APM Control register with APMCH_EN bit set. 1 = SMI# was generated by a write access to the APM Control register with the APMC_EN bit set.
4	<b>SLP_SMI_STS</b> — R/WC. Software clears this bit by writing a 1 to the bit location. 0 = No SMI# caused by write of 1 to SLP_EN bit when SLP_SMI_EN bit is also set. 1 = Indicates an SMI# was caused by a write of 1 to SLP_EN bit when SLP_SMI_EN bit is also set.
3	<b>LEGACY_USB_STS</b> — RO. This bit is a logical OR of each of the SMI status bits in the USB Legacy Keyboard/Mouse Control Registers ANDed with the corresponding enable bits. This bit will not be active if the enable bits are not set. 0 = SMI# was not generated by USB Legacy event. 1 = SMI# was generated by USB Legacy event.
2	<b>BIOS_STS</b> — R/WC. 0 = No SMI# generated due to ACPI software requesting attention. 1 = This bit gets set by hardware when a 1 is written by software to the GBL_RLS bit (D31:F0:PMBase + 04h:bit 2). When both the BIOS_EN bit (D31:F0:PMBase + 30h:bit 2) and the BIOS_STS bit are set, an SMI# will be generated. The BIOS_STS bit is cleared when software writes a 1 to its bit position.
1:0	Reserved

### 9.8.3.16 ALT\_GP\_SMI\_EN—Alternate GPI SMI Enable Register

I/O Address:	PMBASE + 38h	Attribute:	R/W
Default Value:	0000h	Size:	16-bit
Lockable:	No	Usage:	ACPI or Legacy
Power Well:	Resume		

Bit	Description
15:0	<b>Alternate GPI SMI Enable</b> — R/W. These bits are used to enable the corresponding GPIO to cause an SMI#. For these bits to have any effect, the following must be true. <ul style="list-style-type: none"> <li>The corresponding bit in the ALT_GP_SMI_EN register is set.</li> <li>The corresponding GPI must be routed in the GPI_ROUT register to cause an SMI.</li> <li>The corresponding GPIO must be implemented.</li> </ul> <b>NOTE:</b> Mapping is as follows: bit 15 corresponds to GPIO15... bit 0 corresponds to GPIO0.



### 9.8.3.17 ALT\_GP\_SMI\_STS—Alternate GPI SMI Status Register

I/O Address:	PMBASE + 3Ah	Attribute:	R/WC
Default Value:	0000h	Size:	16-bit
Lockable:	No	Usage:	ACPI or Legacy
Power Well:	Resume		

Bit	Description
15:0	<p><b>Alternate GPI SMI Status</b> — R/WC. These bits report the status of the corresponding GPIOs.</p> <p>0 = Inactive. Software clears this bit by writing a 1 to it.</p> <p>1 = Active</p> <p>These bits are sticky. If the following conditions are true, then an SMI# will be generated and the GPE0_STS bit set:</p> <ul style="list-style-type: none"> <li>The corresponding bit in the ALT_GPI_SMI_EN register (PMBASE + 38h) is set</li> <li>The corresponding GPIO must be routed in the GPI_ROUT register to cause an SMI.</li> <li>The corresponding GPIO must be implemented.</li> </ul> <p>All bits are in the resume well. Default for these bits is dependent on the state of the GPIO pins.</p>

### 9.8.3.18 GPE\_CNTL— General Purpose Control Register

I/O Address:	PMBASE + 42h	Attribute:	R/W
Default Value:	00h	Size:	8-bit
Lockable:	No	Usage:	ACPI or Legacy
Power Well:	Resume		

Bit	Description
8:2	Reserved
1	<p><b>SWGPE_CTRL</b>— R/W. This bit allows software to control the assertion of SWGPE_STS bit. This bit is used by hardware as the level input signal for the SWGPE_STS bit in the GPE0_STS register. When SWGPE_CTRL is 1, SWGPE_STS will be set to 1, and writes to SWGPE_STS with a value of 1 to clear SWGPE_STS will result in SWGPE_STS being set back to 1 by hardware. When SWGPE_CTRL is 0, writes to SWGPE_STS with a value of 1 will clear SWGPE_STS to 0.</p>
0	<p><b>THRM#_POL</b> — R/W. This bit controls the polarity of the THRM# pin needed to set the THRM_STS bit.</p> <p>0 = Low value on the THRM# signal will set the THRM_STS bit.</p> <p>1 = HIGH value on the THRM# signal will set the THRM_STS bit.</p>



### 9.8.3.19 DEVACT\_STS — Device Activity Status Register

I/O Address:	PMBASE + 44h	Attribute:	R/WC
Default Value:	0000h	Size:	16-bit
Lockable:	No	Usage:	Legacy Only
Power Well:	Core		

Each bit indicates if an access has occurred to the corresponding device's trap range, or for bits 6:9 if the corresponding PCI interrupt is active. This register is used in conjunction with the Periodic SMI# timer to detect any system activity for legacy power management. The periodic SMI# timer indicates if it is the right time to read the DEVACT\_STS register (PMBASE + 44h).

**Note:** Software clears bits that are set in this register by writing a 1 to the bit position.

Bit	Description
15:13	Reserved
12	<b>KBC_ACT_STS</b> — R/WC. KBC (60/64h). 0 = Indicates that there has been no access to this device's I/O range. 1 = This device's I/O range has been accessed. Clear this bit by writing a 1 to the bit location.
11:10	Reserved
9	<b>PIRODH_ACT_STS</b> — R/WC. PIRQ[D or H]. 0 = The corresponding PCI interrupts have not been active. 1 = At least one of the corresponding PCI interrupts has been active. Clear this bit by writing a 1 to the bit location.
8	<b>PIROCG_ACT_STS</b> — R/WC. PIRQ[C or G]. 0 = The corresponding PCI interrupts have not been active. 1 = At least one of the corresponding PCI interrupts has been active. Clear this bit by writing a 1 to the bit location.
7	<b>PIROBF_ACT_STS</b> — R/WC. PIRQ[B or F]. 0 = The corresponding PCI interrupts have not been active. 1 = At least one of the corresponding PCI interrupts has been active. Clear this bit by writing a 1 to the bit location.
6	<b>PIROAE_ACT_STS</b> — R/WC. PIRQ[A or E]. 0 = The corresponding PCI interrupts have not been active. 1 = At least one of the corresponding PCI interrupts has been active. Clear this bit by writing a 1 to the bit location.
5:1	Reserved
0 Desktop Only)	Reserved
0 (Mobile Only)	<b>IDE_ACT_STS</b> — R/WC. IDE Primary Drive 0 and Drive 1. 0 = Indicates that there has been no access to this device's I/O range. 1 = This device's I/O range has been accessed. The enable bit is in the ATC register (D31:F1:Offset C0h). Clear this bit by writing a 1 to the bit location.



**9.8.3.20 SS\_CNT— Intel SpeedStep® Technology Control Register (Mobile Only)**

I/O Address:	PMBASE + 50h	Attribute:	R/W (special)
Default Value	01h	Size:	8-bit
Lockable:	No	Usage:	ACPI/Legacy
Power Well:	Core		

**Note:** Writes to this register will initiate an Intel SpeedStep technology transition that involves a temporary transition to a C3-like state in which the STPCLK# signal will go active. An Intel SpeedStep technology transition **always** occur on writes to the SS\_CNT register, even if the value written to SS\_STATE is the same as the previous value (after this “transition” the system would still be in the same Intel SpeedStep technology state). If the SS\_EN bit is 0, then writes to this register will have no effect and reads will return 0.

Bit	Description
7:1	Reserved
0	<p><b>SS_STATE</b> (Intel SpeedStep® technology State) — R/W (Special). When this bit is read, it returns the last value written to this register. By convention, this will be the current Intel SpeedStep technology state. Writes to this register causes a change to the Intel SpeedStep technology state indicated by the value written to this bit. If the new value for SS_STATE is the same as the previous value, then transition will still occur.</p> <p>0 = High power state. 1 = Low power state</p> <p><b>NOTE:</b> This is only a convention because the transition is the same regardless of the value written to this bit.</p>

**9.8.3.21 C3\_RES— C3 Residency Register (Mobile Only)**

I/O Address:	PMBASE + 54h	Attribute:	R/W/RO
Default Value	00000000h	Size:	32-bit
Lockable:	No	Usage:	ACPI/Legacy
Power Well:	Core		

Software may only write this register during system initialization to set the state of the C3\_RESIDENCY\_MODE bit. It must not be written while the timer is in use.

Bit	Description
31:24	Reserved
23:0	<p><b>C3_RESIDENCY</b> — RO. The value in this field increments at the same rate as the Power Management Timer. If the C3_RESEDENCY_MODE bit is clear, this field automatically resets to 0 at the point when the Lvl3 or Lvl4 read occurs. If the C3_RESIDENCY_MODE bit is set, the register does not reset when the Lvl3 or Lvl4 read occurs. In either mode, it increments while STP_CPU# is active (i.e., the processor is in a C3 or C4 state). This field will roll over in the same way as the PM Timer, however the most significant bit is NOT sticky.</p> <p>Software is responsible for reading this field before performing the Lvl3/4 transition. Software must also check for rollover if the maximum time in C3/C4 could be exceeded.</p> <p><b>NOTE:</b> Hardware reset is the only reset of this counter field.</p>



### 9.8.3.22 C5\_RES— C5 Residency Register (Mobile Only)

I/O Address:	PMBASE +58h	Attribute:	R/W/RO
Default Value	00000000h	Size:	32-bit
Lockable:	No	Usage:	ACPI/Legacy
Power Well:	Core		

Software may only write this register during system initialization to set the state of the C5\_RESIDENCY\_MODE bit. It must not be written while the timer is in use.

Bit	Description
31:24	<b>Reserved</b>
23:0	<p><b>C5_RESIDENCY — RO.</b> The value in this field increments at the same rate as the Power Management Timer. If the C5_RESEDENCY_MODE bit is clear, this field automatically resets to 0 at the point when the Lvl5 or Lvl6 read occurs. If the C5_RESIDENCY_MODE bit is set, the register does not reset when the Lvl5 or Lvl6 read occurs. In either mode, it increments while STP_CPU# is active (i.e., the processor is in C3/C4/C5/C6 state). This field will roll over in the same way as the PM Timer, however the most significant bit is NOT sticky.</p> <p>Software is responsible for reading this field before performing the Lvl5/6 transition. Software must also check for rollover if the maximum time in C5/C6 could be exceeded.</p> <p><b>NOTE:</b> Hardware reset is the only reset of this counter field.</p>



## 9.9 System Management TCO Registers (D31:F0)

The TCO logic is accessed via registers mapped to the PCI configuration space (Device 31:Function 0) and the system I/O space. For TCO PCI Configuration registers, see LPC Device 31:Function 0 PCI Configuration registers.

### TCO Register I/O Map

The TCO I/O registers reside in a 32-byte range pointed to by a TCOBASE value, which is, PMBASE + 60h in the PCI config space. The following table shows the mapping of the registers within that 32-byte range. Each register is described in the following sections.

Table 116. TCO I/O Register Address Map

TCOBASE + Offset	Mnemonic	Register Name	Default	Type
00h–01h	TCO_RLD	TCO Timer Reload and Current Value	0000h	R/W
02h	TCO_DAT_IN	TCO Data In	00h	R/W
03h	TCO_DAT_OUT	TCO Data Out	00h	R/W
04h–05h	TCO1_STS	TCO1 Status	0000h	R/WC, RO
06h–07h	TCO2_STS	TCO2 Status	0000h	R/W, R/WC
08h–09h	TCO1_CNT	TCO1 Control	0000h	R/W, R/W (special), R/WC
0Ah–0Bh	TCO2_CNT	TCO2 Control	0008h	R/W
0Ch–0Dh	TCO_MESSAGE1, TCO_MESSAGE2	TCO Message 1 and 2	00h	R/W
0Eh	TCO_WDCNT	Watchdog Control	00h	R/W
0Fh	—	Reserved	—	—
10h	SW_IRQ_GEN	Software IRQ Generation	03h	R/W
11h	—	Reserved	—	—
12h–13h	TCO_TMR	TCO Timer Initial Value	0004h	R/W
14h–1Fh	—	Reserved	—	—

### 9.9.1 TCO\_RLD—TCO Timer Reload and Current Value Register

I/O Address: TCOBASE + 00h      Attribute: R/W  
 Default Value: 0000h      Size: 16-bit  
 Lockable: No      Power Well: Core

Bit	Description
15:10	Reserved
9:0	<b>TCO Timer Value</b> — R/W. Reading this register will return the current count of the TCO timer. Writing any value to this register will reload the timer to prevent the timeout.





### 9.9.2 TCO\_DAT\_IN—TCO Data In Register

I/O Address: TCOBASE +02h      Attribute: R/W  
 Default Value: 00h      Size: 8-bit  
 Lockable: No      Power Well: Core

Bit	Description
7:0	<b>TCO Data In Value</b> — R/W. This data register field is used for passing commands from the OS to the SMI handler. Writes to this register will cause an SMI and set the SW_TCO_SMI bit in the TCO1_STS register (D31:F0:04h).

### 9.9.3 TCO\_DAT\_OUT—TCO Data Out Register

I/O Address: TCOBASE +03h      Attribute: R/W  
 Default Value: 00h      Size: 8-bit  
 Lockable: No      Power Well: Core

Bit	Description
7:0	<b>TCO Data Out Value</b> — R/W. This data register field is used for passing commands from the SMI handler to the OS. Writes to this register will set the TCO_INT_STS bit in the TCO_STS register. It will also cause an interrupt, as selected by the TCO_INT_SEL bits.

### 9.9.4 TCO1\_STS—TCO1 Status Register

I/O Address: TCOBASE +04h      Attribute: R/WC, RO  
 Default Value: 0000h      Size: 16-bit  
 Lockable: No      Power Well: Core  
 (Except bit 7, in RTC)

Bit	Description
15:13	Reserved
12	<b>DMISERR_STS</b> — R/WC. 0 = Software clears this bit by writing a 1 to it. 1 = ICH8 received a DMI special cycle message via DMI indicating that it wants to cause an SERR#. The software must read the (G)MCH to determine the reason for the SERR#.
11	Reserved
10	<b>DMISMI_STS</b> — R/WC. 0 = Software clears this bit by writing a 1 to it. 1 = ICH8 received a DMI special cycle message via DMI indicating that it wants to cause an SMI. The software must read the (G)MCH to determine the reason for the SMI.
9	<b>DMISCI_STS</b> — R/WC. 0 = Software clears this bit by writing a 1 to it. 1 = ICH8 received a DMI special cycle message via DMI indicating that it wants to cause an SCI. The software must read the (G)MCH to determine the reason for the SCI.



Bit	Description
8	<p><b>BIOSWR_STS</b> — R/WC.</p> <p>0 = Software clears this bit by writing a 1 to it.            1 = ICH8 sets this bit and generates an SMI# to indicate an invalid attempt to write to the BIOS. This occurs when either:            a) The BIOSWP bit is changed from 0 to 1 and the BLD bit is also set, or            b) any write is attempted to the BIOS and the BIOSWP bit is also set.</p> <p><b>NOTE:</b> On write cycles attempted to the 4 MB lower alias to the BIOS space, the BIOSWR_STS will not be set.</p>
7	<p><b>NEWCENTURY_STS</b> — R/WC. This bit is in the RTC well.</p> <p>0 = Cleared by writing a 1 to the bit position or by RTCRST# going active.            1 = This bit is set when the Year byte (RTC I/O space, index offset 09h) rolls over from 99 to 00. Setting this bit will cause an SMI# (but not a wake event).</p> <p><b>NOTE:</b> The NEWCENTURY_STS bit is not valid when the RTC battery is first installed (or when RTC power has not been maintained). Software can determine if RTC power has not been maintained by checking the RTC_PWR_STS bit (D31:F0:A4h, bit 2), or by other means (such as a checksum on RTC RAM). If RTC power is determined to have not been maintained, BIOS should set the time to a valid value and then clear the NEWCENTURY_STS bit.</p> <p>The NEWCENTURY_STS bit may take up to 3 RTC clocks for the bit to be cleared after a 1 is written to the bit to clear it. After writing a 1 to this bit, software should not exit the SMI handler until verifying that the bit has actually been cleared. This will ensure that the SMI is not re-entered.</p>
6:4	Reserved
3	<p><b>TIMEOUT</b> — R/WC.</p> <p>0 = Software clears this bit by writing a 1 to it.            1 = Set by ICH8 to indicate that the SMI was caused by the TCO timer reaching 0.</p>
2	<p><b>TCO_INT_STS</b> — R/WC.</p> <p>0 = Software clears this bit by writing a 1 to it.            1 = SMI handler caused the interrupt by writing to the TCO_DAT_OUT register (TCOBASE + 03h).</p>
1	<p><b>SW_TCO_SMI</b> — R/WC.</p> <p>0 = Software clears this bit by writing a 1 to it.            1 = Software caused an SMI# by writing to the TCO_DAT_IN register (TCOBASE + 02h).</p>
0	<p><b>NMI2SMI_STS</b> — RO.</p> <p>0 = Cleared by clearing the associated NMI status bit.            1 = Set by the ICH8 when an SMI# occurs because an event occurred that would otherwise have caused an NMI (because NMI2SMI_EN is set).</p>



### 9.9.5 TCO2\_STS—TCO2 Status Register

I/O Address:	TCOBASE +06h	Attribute:	R/W, R/WC
Default Value:	0000h	Size:	16-bit
Lockable:	No	Power Well:	Resume (Except Bit 0, in RTC)

Bit	Description
15:6	Reserved
5	<p><b>ME_WAKE_STS</b> — R/WC. This bit is set when the ME generates a Non-Maskable wake event, and is not affected by any other enable bit. When this bit is set, the Host Power Management logic wakes to S0.</p> <p>This bit is only set by hardware and can only be reset by writing a one to this bit position. This bit is not affected by hard resets caused by a CF9 write, but is reset by RSMRST.</p>
4	<p><b>SMLink Slave SMI Status (SMLINK_SLV_SMI_STS)</b> — R/WC. Allow the software to go directly into pre-determined sleep state. This avoids race conditions. Software clears this bit by writing a 1 to it.</p> <p>0 = The bit is reset by RSMRST#, but not due to the PCI Reset associated with exit from S3–S5 states.</p> <p>1 = ICH8 sets this bit to 1 when it receives the SMI message on the SMLink's Slave Interface.</p>
3	Reserved
2	<p><b>BOOT_STS</b> — R/WC.</p> <p>0 = Cleared by ICH8 based on RSMRST# or by software writing a 1 to this bit. Note that software should first clear the SECOND_TO_STS bit before writing a 1 to clear the BOOT_STS bit.</p> <p>1 = Set to 1 when the SECOND_TO_STS bit goes from 0 to 1 and the processor has not fetched the first instruction.</p> <p>If rebooting due to a second TCO timer timeout, and if the BOOT_STS bit is set, the ICH8 will reboot using the 'safe' multiplier (1111). This allows the system to recover from a processor frequency multiplier that is too high, and allows the BIOS to check the BOOT_STS bit at boot. If the bit is set and the frequency multiplier is 1111, then the BIOS knows that the processor has been programmed to an invalid multiplier.</p>
1	<p><b>SECOND_TO_STS</b> — R/WC.</p> <p>0 = Software clears this bit by writing a 1 to it, or by a RSMRST#.</p> <p>1 = ICH8 sets this bit to 1 to indicate that the TIMEOUT bit had been (or is currently) set and a second timeout occurred before the TCO_RLD register was written. If this bit is set and the NO_REBOOT config bit is 0, then the ICH8 will reboot the system after the second timeout. The reboot is done by asserting PLTRST#.</p>



Bit	Description
0	<p><b>Intruder Detect (INTRD_DET) — R/WC.</b>            0 = Software clears this bit by writing a 1 to it, or by RTCRST# assertion.            1 = Set by ICH8 to indicate that an intrusion was detected. This bit is set even if the system is in G3 state.</p> <p><b>NOTE:</b> This bit has a recovery time. After writing a 1 to this bit position (to clear it), the bit may be read back as a 1 for up to 65 microseconds before it is read as a 0. Software must be aware of this recovery time when reading this bit after clearing it.</p> <p><b>NOTE:</b> If the INTRUDER# signal is active when the software attempts to clear the INTRD_DET bit, the bit will remain as a 1, and the SMI# will be generated again immediately. The SMI handler can clear the INTRD_SEL bits (TCOBASE + 0Ah, bits 2:1), to avoid further SMIs. However, if the INTRUDER# signal goes inactive and then active again, there will not be further SMI's (because the INTRD_SEL bits would select that no SMI# be generated).</p> <p><b>NOTE:</b> If the INTRUDER# signal goes inactive some point after the INTRD_DET bit is written as a 1, then the INTRD_DET signal will go to a 0 when INTRUDER# input signal goes inactive. Note that this is slightly different than a classic sticky bit, since most sticky bits would remain active indefinitely when the signal goes active and would immediately go inactive when a 1 is written to the bit</p>

### 9.9.6 TCO1\_CNT—TCO1 Control Register

I/O Address: TCOBASE +08h      Attribute: R/W, R/W (special), R/WC  
 Default Value: 0000h      Size: 16-bit  
 Lockable: No      Power Well: Core

Bit	Description															
15:13	Reserved															
12	<p><b>TCO_LOCK — R/W (special).</b> When set to 1, this bit prevents writes from changing the TCO_EN bit (in offset 30h of Power Management I/O space). Once this bit is set to 1, it can not be cleared by software writing a 0 to this bit location. A core-well reset is required to change this bit from 1 to 0. This bit defaults to 0.</p>															
11	<p><b>TCO Timer Halt (TCO_TMR_HLT) — R/W.</b>            0 = The TCO Timer is enabled to count.            1 = The TCO Timer will halt. It will not count, and thus cannot reach a value that will cause an SMI# or set the SECOND_TO_STS bit. When set, this bit will prevent rebooting and prevent Alert On LAN event messages from being transmitted on the SMLINK (but not Alert On LAN* heartbeat messages).</p>															
10	Reserved															
9	<p><b>NMI2SMI_EN — R/W.</b>            0 = Normal NMI functionality.            1 = Forces all NMIs to instead cause SMIs. The functionality of this bit is dependent upon the settings of the NMI_EN bit and the GBL_SMI_EN bit as detailed in the following table:</p> <table border="1"> <thead> <tr> <th>NMI_EN</th> <th>GBL_SMI_EN</th> <th>Description</th> </tr> </thead> <tbody> <tr> <td>0b</td> <td>0b</td> <td>No SMI# at all because GBL_SMI_EN = 0</td> </tr> <tr> <td>0b</td> <td>1b</td> <td>SMI# will be caused due to NMI events</td> </tr> <tr> <td>1b</td> <td>0b</td> <td>No SMI# at all because GBL_SMI_EN = 0</td> </tr> <tr> <td>1b</td> <td>1b</td> <td>No SMI# due to NMI because NMI_EN = 1</td> </tr> </tbody> </table>	NMI_EN	GBL_SMI_EN	Description	0b	0b	No SMI# at all because GBL_SMI_EN = 0	0b	1b	SMI# will be caused due to NMI events	1b	0b	No SMI# at all because GBL_SMI_EN = 0	1b	1b	No SMI# due to NMI because NMI_EN = 1
NMI_EN	GBL_SMI_EN	Description														
0b	0b	No SMI# at all because GBL_SMI_EN = 0														
0b	1b	SMI# will be caused due to NMI events														
1b	0b	No SMI# at all because GBL_SMI_EN = 0														
1b	1b	No SMI# due to NMI because NMI_EN = 1														



Bit	Description
8	<b>NMI_NOW</b> — R/W.C. 0 = Software clears this bit by writing a 1 to it. The NMI handler is expected to clear this bit. Another NMI will not be generated until the bit is cleared. 1 = Writing a 1 to this bit causes an NMI. This allows the BIOS or SMI handler to force an entry to the NMI handler.
7:0	Reserved

### 9.9.7 TCO2\_CNT—TCO2 Control Register

I/O Address: TCOBASE +0Ah      Attribute: R/W  
 Default Value: 0008h      Size: 16-bit  
 Lockable: No      Power Well: Resume

Bit	Description
15:6	Reserved
5:4	<b>OS_POLICY</b> — R/W. OS-based software writes to these bits to select the policy that the BIOS will use after the platform resets due the WDT. The following convention is recommended for the BIOS and OS: 00 = Boot normally 01 = Shut down 10 = Don't load OS. Hold in pre-boot state and use LAN to determine next step 11 = Reserved  <b>NOTE:</b> These are just scratchpad bits. They should not be reset when the TCO logic resets the platform due to Watchdog Timer.
3	<b>GPIO11_ALERT_DISABLE</b> — R/W. At reset (via RSMRST# asserted) this bit is set and GPIO[11] alerts are disabled. 0 = Enable. 1 = Disable GPIO11/SMBALERT# as an alert source for the heartbeats and the SMBus slave.
2:1	<b>INTRD_SEL</b> — R/W. This field selects the action to take if the INTRUDER# signal goes active. 00 = No interrupt or SMI# 01 = Interrupt (as selected by TCO_INT_SEL). 10 = SMI 11 = Reserved
0	Reserved

### 9.9.8 TCO\_MESSAGE1 and TCO\_MESSAGE2 Registers

I/O Address: TCOBASE +0Ch (Message 1) Attribute: R/W  
 TCOBASE +0Dh (Message 2)  
 Default Value: 00h      Size: 8-bit  
 Lockable: No      Power Well: Resume

Bit	Description
7:0	<b>TCO_MESSAGE[n]</b> — R/W. BIOS can write into these registers to indicate its boot progress. The external microcontroller can read these registers to monitor the boot progress.



### 9.9.9 TCO\_WDCNT—TCO Watchdog Control Register

Offset Address: TCOBASE + 0Eh      Attribute: R/W  
 Default Value: 00h      Size: 8 bits  
 Power Well: Resume

Bit	Description
7:0	The BIOS or system management software can write into this register to indicate more details on the boot progress. The register will reset to 00h based on a RSMRST# (but not PLTRST#). The external microcontroller can read this register to monitor boot progress.

### 9.9.10 SW\_IRQ\_GEN—Software IRQ Generation Register

Offset Address: TCOBASE + 10h      Attribute: R/W  
 Default Value: 03h      Size: 8 bits  
 Power Well: Core

Bit	Description
7:2	Reserved
1	<b>IRQ12_CAUSE</b> — R/W. The state of this bit is logically ANDed with the IRQ12 signal as received by the ICH8's SERIRQ logic. This bit must be a 1 (default) if the ICH8 is expected to receive IRQ12 assertions from a SERIRQ device.
0	<b>IRQ1_CAUSE</b> — R/W. The state of this bit is logically ANDed with the IRQ1 signal as received by the ICH8's SERIRQ logic. This bit must be a 1 (default) if the ICH8 is expected to receive IRQ1 assertions from a SERIRQ device.

### 9.9.11 TCO\_TMR—TCO Timer Initial Value Register

I/O Address: TCOBASE + 12h      Attribute: R/W  
 Default Value: 0004h      Size: 16-bit  
 Lockable: No      Power Well: Core

Bit	Description
15:10	Reserved
9:0	<b>TCO Timer Initial Value</b> — R/W. Value that is loaded into the timer each time the TCO_RLD register is written. Values of 0000h or 0001h will be ignored and should not be attempted. The timer is clocked at approximately 0.6 seconds, and thus allows timeouts ranging from 1.2 second to 613.8 seconds. Note: The timer has an error of ± 1 tick (0.6s). The TCO Timer will only count down in the S0 state.



## 9.10 General Purpose I/O Registers (D31:F0)

The control for the general purpose I/O signals is handled through a separate 64-byte I/O space. The base offset for this space is selected by the GPIOBASE register.

**Table 117. Registers to Control GPIO Address Map**

GPIOBASE + Offset	Mnemonic	Register Name	Default	Access
00h–03h	GPIO_USE_SEL	GPIO Use Select	197F75FFh (Desktop) / 197E55FFh (Mobile)	R/W
04h–07h	GP_IO_SEL	GPIO Input/Output Select	E0EA7FFFh	R/W
08h–0Bh	—	Reserved	—	—
0Ch–0Fh	GP_LVL	GPIO Level for Input or Output	02FE8000h	R/W
10h–13h	GPIO_USE_SEL Override (LOW)	GPIO Use Select Override Low	00000000h	R/W
14h–17h	—	Reserved	—	—
18h–1Bh	GPO_BLINK	GPIO Blink Enable	00040000h	R/W
1Ch–1Fh	GP_SER_BLINK[31:0]	GP Serial Blink [31:0]	00000000h	R/W
20–23h	GP_SB_CMDSTS[31:0]	GP Serial Blink Command Status [31:0]	00000800h	R/W
24–27h	GP_SB_DATA[31:0]	GP Serial Blink Data [31:0]	00000000h	R/W
28–2Bh	—	Reserved	—	—
2C–2Fh	GPI_INV	GPIO Signal Invert	00000000h	R/W
30h–33h	GPIO_USE_SEL2	GPIO Use Select 2 [63:32]	000100FFh (Desktop) / 000100FEh (Mobile)	R/W
34h–37h	GP_IO_SEL2	GPIO Input/Output Select 2 [63:32]	00550FF0h	R/W
38h–3Bh	GP_LVL2	GPIO Level for Input or Output 2 [63:32]	00AA0003h	R/W
3Ch–3Fh	GPIO_USE_SEL Override (HIGH)	GPIO Use Select Override High	00000000h	R/W



### 9.10.1 GPIO\_USE\_SEL—GPIO Use Select Register

Offset Address:	GPIOBASE + 00h	Attribute:	R/W
Default Value:	197F75FFh (Desktop) 197E55FFh (Mobile)	Size:	32-bit
Lockable:	No	Power Well:	Core for 0: 7, 16:23, Resume for 8: 15, 24:31

Bit	Description
31:0	<p><b>GPIO_USE_SEL[31:0]</b> — R/W. Each bit in this register enables the corresponding GPIO (if it exists) to be used as a GPIO, rather than for the native function.</p> <p>0 = Signal used as native function. 1 = Signal used as a GPIO.</p> <p><b>NOTES:</b></p> <ol style="list-style-type: none"> <li>The following bits are always 1 because they are unmultiplexed: 8, 18, 20. The following bits are also unmultiplexed in desktop configuration: 12, 13, 16</li> <li>If GPIO[n] does not exist, then the bit in this register will always read as 0 and writes will have no effect.</li> <li>When RSMRST# is asserted, all multiplexed signals in the resume and core wells are configured as their default function. When just PLTRST# is asserted, the GPIO in the core well are configured as their default function.</li> <li>When configured to GPIO mode, the multiplexing logic will present the inactive state to native logic that uses the pin as an input.</li> <li>All GPIOs are reset to the default state by CF9h reset except GPIO24</li> <li>If the GPIO use is configured by a soft strap, the corresponding bit in this register is ignored. This applies to the following ICH8M bits: [13:12].</li> </ol>

### 9.10.2 GP\_IO\_SEL—GPIO Input/Output Select Register

Offset Address:	GPIOBASE +04h	Attribute:	R/W
Default Value:	E0EA7FFFh	Size:	32-bit
Lockable:	No	Power Well:	Core for 0: 7, 16:23, Resume for 8: 15, 24:31

Bit	Description
31:0	<p><b>GP_IO_SEL[31:0]</b> — R/W. When configured in native mode (GPIO_USE_SEL[n] is 0), writes to these bits have no effect. The value reported in this register is undefined when programmed as native mode.</p> <p>0 = Output. The corresponding GPIO signal is an output. 1 = Input. The corresponding GPIO signal is an input.</p>





### 9.10.3 GP\_LVL—GPIO Level for Input or Output Register

Offset Address:	GPIOBASE +0Ch	Attribute:	R/W
Default Value:	02FE8000h	Size:	32-bit
Lockable:	No	Power Well:	Core for 0: 7, 16:23, Resume for 8: 15, 24: 31

Bit	Description
31:0	<p><b>GP_LVL[31:0]</b>— R/W:</p> <p>If GPIO[n] is programmed to be an output (via the corresponding bit in the GP_IO_SEL register), then the corresponding GP_LVL[n] bit can be updated by software to drive a high or low value on the output pin. 1 = high, 0 = low.</p> <p>If GPIO[n] is programmed as an input, then the corresponding GP_LVL bit reflects the state of the input signal (1 = high, 0 = low.) and writes will have no effect.</p> <p>When configured in native mode (GPIO_USE_SEL[n] is 0), writes to these bits have no effect. The value reported in this register is undefined when programmed as native mode.</p>

### 9.10.4 GPIO\_USE\_SEL Override Register (LOW)—GPIO Use Select Override Register Low

Offset Address:	GPIOBASE +10h	Attribute:	R/W
Default Value:	00000000h	Size:	32-bit
Lockable:	No	Power Well:	Core for 0: 7, 16:23, Resume for 8: 15, 24: 31

Bit	Description
31:0	<p><b>GPIO_USE_SEL Override [31:0]</b> — R/W. Each bit in this register enables the corresponding GPIO (if it exists) to be used as a GPIO, rather than for the native function.</p> <p>0 = Signal used as native function. 1 = Signal used as a GPIO.</p> <p>Once a bit is set to 1b, it can only be cleared a reset. Bits 31:24 and 15:8 are cleared by RSMRST# and CF9h events. Bits 23:16 and 7:0 are cleared by PLTRST# events.</p> <p>If the corresponding GPIO is not multiplexed with Native functionality or not implemented at all, this bit has no effect.</p> <p>This register corresponds to GPIO[31:0].</p>



### 9.10.5 GPO\_BLINK—GPO Blink Enable Register

Offset Address:	GPIOBASE +18h	Attribute:	R/W
Default Value:	00040000h	Size:	32-bit
Lockable:	No	Power Well:	Core for 0: 7, 16: 23, Resume for 8: 15, 24: 31

Bit	Description
31:0	<p><b>GP_BLINK[31:0]</b> — R/W. The setting of this bit has no effect if the corresponding GPIO signal is programmed as an input.</p> <p>0 = The corresponding GPIO will function normally.</p> <p>1 = If the corresponding GPIO is programmed as an output, the output signal will blink at a rate of approximately once per second. The high and low times have approximately 0.5 seconds each. The GP_LVL bit is not altered when this bit is set.</p> <p>The value of the corresponding GP_LVL bit remains unchanged during the blink process, and does not effect the blink in any way. The GP_LVL bit is not altered when programmed to blink. It will remain at its previous value.</p> <p>These bits correspond to GPIO in the Resume well. These bits revert to the default value based on RSMRST# or a write to the CF9h register (but not just on PLTRST#).</p>

**NOTE:** GPIO18 will blink by default immediately after reset. This signal could be connected to an LED to indicate a failed boot (by programming BIOS to clear GP\_BLINK18 after successful POST).

### 9.10.6 GP\_SER\_BLINK[31:0]—GP Serial Blink

Offset Address:	GPIOBASE +1Ch	Attribute:	R/W
Default Value:	00000000h	Size:	32-bit
Lockable:	No	Power Well:	Core for 0: 7, 16: 23, Resume for 8: 15, 24: 31

Bit	Description
31:0	<p><b>GP_SER_BLINK[31:0]:</b> The setting of this bit has no effect if the corresponding GPIO is programmed as an input or if the corresponding GPIO has the GPO_BLINK bit set.</p> <p>When set to a 0, the corresponding GPIO will function normally.</p> <p>When using serial blink, this bit should be set to a 1 while the corresponding GP_IO_SEL bit is set to 1. Setting the GP_IO_SEL bit to 0 after the GP_SER_BLINK bit ensures ICH8 will not drive a 1 on the pin as an output. When this corresponding bit is set to a 1 and the pin is configured to output mode, the serial blink capability is enabled. The ICH8 will serialize messages through an open-drain buffer configuration.</p> <p>The value of the corresponding GP_LVL bit remains unchanged and does not impact the serial blink capability in any way.</p> <p>Writes to this register have no effect when the corresponding pin is configured in native mode and the read value returned is undefined.</p>



### 9.10.7 GP\_SB\_CMDSTS[31:0]—GP Serial Blink Command Status

Offset Address: GPIOBASE +20h      Attribute: R/W  
 Default Value: 00080000h      Size: 32-bit  
 Lockable: No      Power Well: Core

Bit	Description
31:24	Reserved
23:22	<p><b>Data Length Select (DLS):</b> This read/write field determines the number of bytes to serialize on GPIO.</p> <p>00 = Serialize bits 7:0 of GP_SB_DATA (1 byte)            01 = Serialize bits 15:0 of GP_SB_DATA (2 bytes)            10 = Undefined - Software must not write this value            11 = Serialize bits 31:0 of GP_SB_DATA (4 bytes)</p> <p>Software should not modify the value in this register unless the Busy bit is clear. Writes to this register have no effect when the corresponding pin is configured in native mode and the read value returned is undefined.</p>
21:16	<p><b>Data Rate Select (DRS):</b> This read/write field selects the number of 128ns time intervals to count between Manchester data transitions. The default of 8h results in a 1024ns minimum time between transitions. A value of 0h in this register produces undefined behavior.</p> <p>Software should not modify the value in this register unless the Busy bit is clear.</p>
15:9	Reserved
8	<p><b>Busy:</b> This read-only status bit is the hardware indication that a serialization is in progress. Hardware sets this bit to 1 based on the Go bit being set. Hardware clears this bit when the Go bit is cleared by the hardware.</p>
7:1	Reserved
0	<p><b>Go:</b> This bit is set to 1 by software to start the serialization process. Hardware clears the bit after the serialized data is sent. Writes of 0 to this register have no effect. Software should not write this bit to 1 unless the Busy status bit is cleared.</p>

### 9.10.8 GP\_SB\_DATA[31:0]—GP Serial Blink Data

Offset Address: GPIOBASE +24h      Attribute: R/W  
 Default Value: 00000000h      Size: 32-bit  
 Lockable: No      Power Well: Core

Bit	Description
31:0	<p><b>GP_SB_DATA[31:0]:</b> This read-write register contains the data serialized out. The number of bits shifted out are selected through the DLS field in the GP_SB_CMDSTS register. This register should not be modified by software when the Busy bit is set.</p>



### 9.10.9 GPI\_INV—GPIO Signal Invert Register

Offset Address: GPIOBASE +2Ch      Attribute: R/W  
 Default Value: 00000000h      Size: 32-bit  
 Lockable: No      Power Well: CPU I/O for 17, Core for 16, 7:0

Bit	Description
31:0	<p><b>GP_INV[n]</b> — R/W. <b>Input Inversion:</b> This bit only has effect if the corresponding GPIO is used as an input and used by the GPE logic, where the polarity matters. When set to '1', then the GPI is inverted as it is sent to the GPE logic that is using it. This bit has no effect on the value that is reported in the GP_LVL register.</p> <p>These bits are used to allow both active-low and active-high inputs to cause SMI# or SCI. Note that in the S0 or S1 state, the input signal must be active for at least two PCI clocks to ensure detection by the ICH8. In the S3, S4 or S5 states the input signal must be active for at least 2 RTC clocks to ensure detection. The setting of these bits has no effect if the corresponding GPIO is programmed as an output. These bits correspond to GPI that are in the resume well, and will be reset to their default values by RSMRST# or by a write to the CF9h register.</p> <p>0 = The corresponding GPI_STS bit is set when the ICH8 detects the state of the input pin to be high.          1 = The corresponding GPI_STS bit is set when the ICH8 detects the state of the input pin to be low.</p>

### 9.10.10 GPIO\_USE\_SEL2—GPIO Use Select 2 Register[63:32]

Offset Address: GPIOBASE +30h      Attribute: R/W  
 Default Value: 000100FFh (Desktop)      Size: 32-bit  
                   000100FEh (Mobile)  
 Lockable: No      Power Well: Core for  
   0: 7, 16:23, Resume for 8:15,  
   24:31

Bit	Description
31:0	<p><b>GPIO_USE_SEL2[31:0]</b>— R/W. Each bit in this register enables the corresponding GPIO (if it exists) to be used as a GPIO, rather than for the native function.</p> <p>0 = Signal used as native function.          1 = Signal used as a GPIO.</p> <p><b>NOTES:</b></p> <ol style="list-style-type: none"> <li>The following bit is always 1 because it is always unmultiplexed: 0.</li> <li>If GPIO[n] does not exist, then the (n-32) bit in this register will always read as 0 and writes will have no effect. The following bits are always 0: [15:12], [31:24].</li> <li>When RSMRST# is asserted, all multiplexed signals in the resume and core wells are configured as their default function. when just PLTRST# is asserted, the GPIOs in the core well are configured as their default function.</li> <li>When configured to GPIO mode, the multiplexing logic will present the inactive state to native logic that uses the pin as an input.</li> <li>All GPIOs are reset to the default state by CF9h reset (except GPIO24)</li> </ol>



### 9.10.11 GP\_IO\_SEL2—GPIO Input/Output Select 2 Register[63:32]

Offset Address: GPIOBASE +34h      Attribute: R/W  
 Default Value: 00550FF0h      Size: 32-bit  
 Lockable: No      Power Well: CPU I/O for 17, Core for 16, 7:0

Bit	Description
31:24, 15:12	Always 0. No corresponding GPIO.
23:16, 11:0	<p><b>GP_IO_SEL2[49:48, 39:32]</b> — R/W.</p> <p>0 = GPIO signal is programmed as an output.            1 = Corresponding GPIO signal (if enabled in the GPIO_USE_SEL2 register) is programmed as an input.</p> <p>This register corresponds to GPIO[55:48, 43:32]. Bit 0 corresponds to GPIO32.</p>

### 9.10.12 GP\_LVL2—GPIO Level for Input or Output 2 Register[63:32]

Offset Address: GPIOBASE +38h      Attribute: R/W  
 Default Value: 00AA0003h      Size: 32-bit  
 Lockable: No      Power Well: CPU I/O for 17, Core for 16, 7:0

Bit	Description
31:24, 15:12	Reserved. Read-only 0
23:16, 11:0	<p><b>GP_LVL[49:48, 39:32]</b> — R/W.</p> <p>If GPIO[n] is programmed to be an output (via the corresponding bit in the GP_IO_SEL register), then the corresponding GP_LVL[n] bit can be updated by software to drive a high or low value on the output pin. 1 = high, 0 = low.</p> <p>If GPIO[n] is programmed as an input, then the corresponding GP_LVL bit reflects the state of the input signal (1 = high, 0 = low.) and writes will have no effect.</p> <p>When configured in native mode (GPIO_USE_SEL[n] is 0), writes to these bits have no effect. The value reported in this register is undefined when programmed as native mode.</p> <p>This register corresponds to GPIO[55:48, 43:32]. Bit 0 corresponds to GPIO32.</p>



### 9.10.13 GPIO\_USE\_SEL Override Register (HIGH)—GPIO Use Select Override Register High

Offset Address: GPIOBASE +3Ch      Attribute: R/W  
Default Value: 00000000h      Size: 32-bit  
Lockable: No      Power Well: Core for 0:7, 16:23,  
Resume for 8:15, 24:31

Bit	Description
31:0	<p><b>GPIO_USE_SEL Override [63:32]</b> — R/W. Each bit in this field corresponds to one of the Host GPIO indexed signals. A 1b in this field forces the corresponding Host Signal used as native function mode, regardless of the Host GPIO_USE_SEL register bit. A 0b in this field leaves the determination of the pin usage to the GPIO_USE_SEL register.</p> <p>Once a bit is set to 1b, it can only be cleared a reset. Bits 31:24 and 15:8 are cleared by RSMRST# and CF9h events. Bits 23:16 and 7:0 are cleared by PLTRST# events. If the corresponding GPIO is not multiplexed with Native functionality or not implemented at all, this bit has no effect.</p> <p>This register corresponds to GPIO[55:48, 43:32]. Bit 0 corresponds to GPIO32.</p>

§ §



# 10 PCI-to-PCI Bridge Registers (D30:F0)

The ICH8 PCI bridge resides in PCI Device 30, Function 0 on bus #0. This implements the buffering and control logic between PCI and the backbone. The arbitration for the PCI bus is handled by this PCI device.

## 10.1 PCI Configuration Registers (D30:F0)

**Note:** Address locations that are not shown should be treated as Reserved (see [Section 6.2](#) for details).

**Table 118. PCI Bridge Register Address Map (PCI-PCI—D30:F0) (Sheet 1 of 2)**

Offset	Mnemonic	Register Name	Default	Type
00h–01h	VID	Vendor Identification	8086h	RO
02h–03h	DID	Device Identification	See register description	RO
04h–05h	PCICMD	PCI Command	0000h	R/W, RO
06h–07h	PSTS	PCI Status	0010h	R/WC, RO
08h	RID	Revision Identification	See register description	RO
09h–0Bh	CC	Class Code	00060401h	RO
0Dh	PMLT	Primary Master Latency Timer	00h	RO
0Eh	HEADTYP	Header Type	81h	RO
18h–1Ah	BNUM	Bus Number	000000h	R/W, RO
1Bh	SMLT	Secondary Master Latency Timer	00h	R/W, RO
1Ch–1Dh	IOBASE_LIMIT	I/O Base and Limit	0000h	R/W, RO
1Eh–1Fh	SECSTS	Secondary Status	0280h	R/WC, RO
20h–23h	MEMBASE_LIMIT	Memory Base and Limit	00000000h	R/W, RO
24h–27h	PREF_MEM_BASE_LIMIT	Prefetchable Memory Base and Limit	00010001h	R/W, RO
28h–2Bh	PMBU32	Prefetchable Memory Upper 32 Bits	00000000h	R/W
2Ch–2Fh	PMLU32	Prefetchable Memory Limit Upper 32 Bits	00000000h	R/W
34h	CAPP	Capability List Pointer	50h	RO
3Ch–3Dh	INTR	Interrupt Information	0000h	R/W, RO
3Eh–3Fh	BCTRL	Bridge Control	0000h	R/WC, RO
40h–41h	SPDH	Secondary PCI Device Hiding	00h	R/W, RO
44h–47h	DTC	Delayed Transaction Control	00000000h	R/W, RO
48h–4Bh	BPS	Bridge Proprietary Status	00000000h	R/WC, RO



Table 118. PCI Bridge Register Address Map (PCI-PCI—D30:F0) (Sheet 2 of 2)

Offset	Mnemonic	Register Name	Default	Type
4Ch–4Fh	BPC	Bridge Policy Configuration	00001200h	R/W RO
50–51h	SVCAP	Subsystem Vendor Capability Pointer	000Dh	RO
54h–57h	SVID	Subsystem Vendor IDs	00000000	R/WO

### 10.1.1 VID— Vendor Identification Register (PCI-PCI—D30:F0)

Offset Address: 00h–01h                      Attribute: RO  
Default Value: 8086h                      Size: 16 bits

Bit	Description
15:0	Vendor ID — RO. This is a 16-bit value assigned to Intel. Intel VID = 8086h.

### 10.1.2 DID— Device Identification Register (PCI-PCI—D30:F0)

Offset Address: 02h–03h                      Attribute: RO  
Default Value: See bit description              Size: 16 bits

Bit	Description
15:0	Device ID — RO. This is a 16-bit value assigned to the PCI bridge. Refer to the <i>Intel® ICH8 Family Specification Update</i> for the value of the Device ID Register.

### 10.1.3 PCICMD—PCI Command (PCI-PCI—D30:F0)

Offset Address: 04h–05h                      Attribute: R/W, RO  
Default Value: 0000h                      Size: 16 bits

Bit	Description
15:11	Reserved
10	Interrupt Disable (ID) — RO. Hardwired to 0. The PCI bridge has no interrupts to disable.
9	Fast Back to Back Enable (FBE) — RO. Hardwired to 0, per the <i>PCI Express* Base Specification, Revision 1.0a</i> .
8	<b>SERR# Enable (SERR_EN)</b> — R/W. 0 = Disable. 1 = Enable the ICH8 to generate an NMI (or SMI# if NMI routed to SMI#) when the D30:F0 SSE bit (offset 06h, bit 14) is set.
7	Wait Cycle Control (WCC) — RO. Hardwired to 0, per the <i>PCI Express* Base Specification, Revision 1.0a</i> .
6	<b>Parity Error Response (PER)</b> — R/W. 0 = The ICH8 ignores parity errors on the PCI bridge. 1 = The ICH8 will set the SSE bit (D30:F0, offset 06h, bit 14) when parity errors are detected on the PCI bridge.
5	VGA Palette Snoop (VPS) — RO. Hardwired to 0, per the <i>PCI Express* Base Specification, Revision 1.0a</i> .





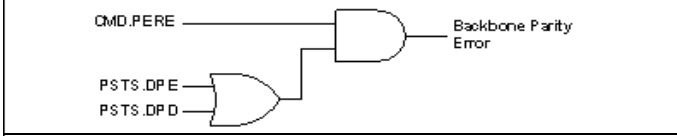
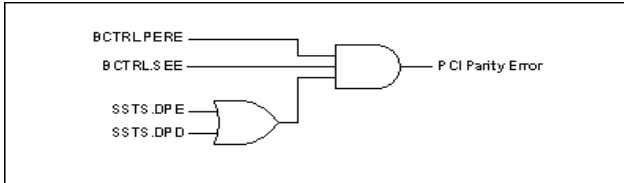
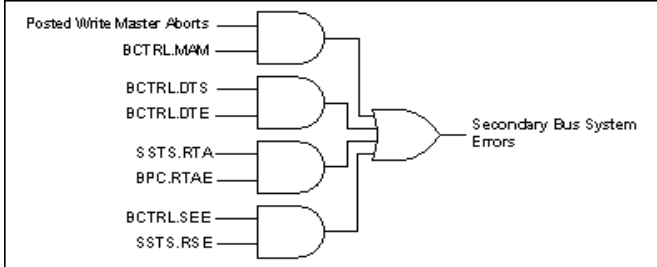
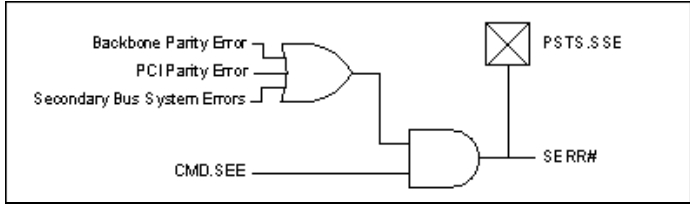
Bit	Description
4	Memory Write and Invalidate Enable (MWE) — RO. Hardwired to 0, per the <i>PCI Express* Base Specification, Revision 1.0a</i>
3	Special Cycle Enable (SCE) — RO. Hardwired to 0, per the <i>PCI Express* Base Specification, Revision 1.0a</i> and the <i>PCI-to-PCI Bridge Specification</i> .
2	<b>Bus Master Enable (BME)</b> — R/W. 0 = Disable 1 = Enable. Allows the PCI-to-PCI bridge to accept cycles from PCI.
1	<b>Memory Space Enable (MSE)</b> — R/W. Controls the response as a target for memory cycles targeting PCI. 0 = Disable 1 = Enable
0	<b>I/O Space Enable (IOSE)</b> — R/W. Controls the response as a target for I/O cycles targeting PCI. 0 = Disable 1 = Enable

#### 10.1.4 PSTS—PCI Status Register (PCI-PCI—D30:F0)

Offset Address: 06h–07h                      Attribute: R/WC, RO  
 Default Value: 0010h                        Size: 16 bits

**Note:** For the writable bits, software must write a 1 to clear bits that are set. Writing a 0 to the bit has no effect.

Bit	Description
15	<b>Detected Parity Error (DPE)</b> — R/WC. 0 = Parity error Not detected. 1 = Indicates that the ICH8 detected a parity error on the internal backbone. This bit gets set even if the Parity Error Response bit (D30:F0:04 bit 6) is not set.

Bit	Description
	<p><b>Signaled System Error (SSE)</b> — R/WC. Several internal and external sources of the bridge can cause SERR#. The first class of errors is parity errors related to the backbone. The PCI bridge captures generic data parity errors (errors it finds on the backbone) as well as errors returned on backbone cycles where the bridge was the master. If either of these two conditions is met, and the primary side of the bridge is enabled for parity error response, SERR# will be captured as shown below.</p>  <p>As with the backbone, the PCI bus captures the same sets of errors. The PCI bridge captures generic data parity errors (errors it finds on PCI) as well as errors returned on PCI cycles where the bridge was the master. If either of these two conditions is met, and the secondary side of the bridge is enabled for parity error response, SERR# will be captured as shown below.</p>  <p>14 The final class of errors is system bus errors. There are three status bits associated with system bus errors, each with a corresponding enable. The diagram capturing this is shown below.</p>  <p>After checking for the three above classes of errors, an SERR# is generated, and PSTS.SSE logs the generation of SERR#, if CMD.SEE (D30:F0:04, bit 8) is set, as shown below.</p> 
13	<p><b>Received Master Abort (RMA)</b> — R/WC.            0 = No master abort received.            1 = Set when the bridge receives a master abort status from the backbone.</p>
12	<p><b>Received Target Abort (RTA)</b> — R/WC.            0 = No target abort received.            1 = Set when the bridge receives a target abort status from the backbone.</p>



Bit	Description
11	<b>Signaled Target Abort (STA)</b> — R/WC. 0 = No signaled target abort 1 = Set when the bridge generates a completion packet with target abort status on the backbone.
10:9	Reserved.
8	<b>Data Parity Error Detected (DPD)</b> — R/WC. 0 = Data parity error Not detected. 1 = Set when the bridge receives a completion packet from the backbone from a previous request, and detects a parity error, and CMD.PERE is set (D30:F0:04, bit 6).
7:5	Reserved.
4	<b>Capabilities List (CLIST)</b> — RO. Hardwired to 1. Capability list exist on the PCI bridge.
3	<b>Interrupt Status (IS)</b> — RO. Hardwired to 0. The PCI bridge does not generate interrupts.
2:0	Reserved

### 10.1.5 RID—Revision Identification Register (PCI-PCI—D30:F0)

Offset Address: 08h    Attribute: RO  
 Default Value: See bit description                                      Size: 8 bits

Bit	Description
7:0	<b>Revision ID</b> — RO. Refer to the <i>Intel® I/O Controller Hub 8 (ICH8) Family Specification Update</i> for the value of the Revision ID Register

### 10.1.6 CC—Class Code Register (PCI-PCI—D30:F0)

Offset Address: 09h-0Bh    Attribute: RO  
 Default Value: 060401h    Size: 24 bits

Bit	Description
23:16	<b>Base Class Code (BCC)</b> — RO. Hardwired to 06h. Indicates this is a bridge device.
15:8	<b>Sub Class Code (SCC)</b> — RO. Hardwired to 04h. Indicates this device is a PCI-to-PCI bridge.
7:0	<b>Programming Interface (PI)</b> — RO. Hardwired to 01h. Indicates the bridge is subtractive decode



### 10.1.7 PMLT—Primary Master Latency Timer Register (PCI-PCI—D30:F0)

Offset Address: 0Dh Attribute: RO  
 Default Value: 00h Size: 8 bits

Bit	Description
7:3	<b>Master Latency Timer Count (MLTC)</b> — RO. Reserved per the <i>PCI Express* Base Specification, Revision 1.0a</i> .
2:0	Reserved

### 10.1.8 HEADTYP—Header Type Register (PCI-PCI—D30:F0)

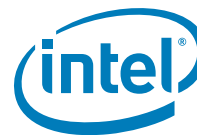
Offset Address: 0Eh Attribute: RO  
 Default Value: 01h Size: 8 bits

Bit	Description
7	<b>Multi-Function Device (MFD)</b> — RO. A 0 indicates a single function device
6:0	<b>Header Type (HTYPE)</b> — RO. This 7-bit field identifies the header layout of the configuration space, which is a PCI-to-PCI bridge in this case.

### 10.1.9 BNUM—Bus Number Register (PCI-PCI—D30:F0)

Offset Address: 18h–1Ah Attribute: R/W, RO  
 Default Value: 000000h Size: 24 bits

Bit	Description
23:16	<b>Subordinate Bus Number (SBBN)</b> — R/W. This field indicates the highest PCI bus number below the bridge.
15:8	<b>Secondary Bus Number (SCBN)</b> — R/W. This field indicates the bus number of PCI.
7:0	<b>Primary Bus Number (PBN)</b> — R/W. This field is default to 00h. In a multiple-ICH8 system, programmable PBN allows an ICH8 to be located on any bus. System configuration software is responsible for initializing these registers to appropriate values. PBN is not used by hardware in determining its bus number.



### 10.1.10 SMLT—Secondary Master Latency Timer Register (PCI-PCI—D30:F0)

Offset Address: 1Bh                              Attribute:        R/W, RO  
 Default Value:  00h                            Size:             8 bits

This timer controls the amount of time the ICH8 PCI-to-PCI bridge will burst data on its secondary interface. The counter starts counting down from the assertion of FRAME#. If the grant is removed, then the expiration of this counter will result in the de-assertion of FRAME#. If the grant has not been removed, then the ICH8 PCI-to-PCI bridge may continue ownership of the bus.

Bit	Description
7:3	<b>Master Latency Timer Count (MLTC)</b> — R/W. This 5-bit field indicates the number of PCI clocks, in 8-clock increments, that the ICH8 remains as master of the bus.
2:0	Reserved

### 10.1.11 IOBASE\_LIMIT—I/O Base and Limit Register (PCI-PCI—D30:F0)

Offset Address: 1Ch-1Dh                        Attribute:        R/W, RO  
 Default Value:  0000h                        Size:             16 bits

Bit	Description
15:12	<b>I/O Limit Address Limit bits[15:12]</b> — R/W. I/O Base bits corresponding to address lines 15:12 for 4-KB alignment. Bits 11:0 are assumed to be padded to FFFh.
11:8	<b>I/O Limit Address Capability (IOLC)</b> — RO. Indicates that the bridge does not support 32-bit I/O addressing.
7:4	<b>I/O Base Address (IOBA)</b> — R/W. I/O Base bits corresponding to address lines 15:12 for 4-KB alignment. Bits 11:0 are assumed to be padded to 000h.
3:0	<b>I/O Base Address Capability (IOBC)</b> — RO. Indicates that the bridge does not support 32-bit I/O addressing.



### 10.1.12 SECSTS—Secondary Status Register (PCI-PCI—D30:F0)

Offset Address: 1Eh–1Fh  
 Default Value: 0280h

Attribute: R/WC, RO  
 Size: 16 bits

**Note:** For the writable bits, software must write a 1 to clear bits that are set. Writing a 0 to the bit has no effect.

Bit	Description
15	<b>Detected Parity Error (DPE)</b> — R/WC. 0 = Parity error <b>not</b> detected. 1 = Intel® ICH8 PCI bridge detected an address or data parity error on the PCI bus
14	<b>Received System Error (RSE)</b> — R/WC. 0 = SERR# assertion <b>not</b> received 1 = SERR# assertion is received on PCI.
13	<b>Received Master Abort (RMA)</b> — R/WC. 0 = No master abort. 1 = This bit is set whenever the bridge is acting as an initiator on the PCI bus and the cycle is master-aborted. For (G)MCH/ICH8 interface packets that have completion required, this must also cause a target abort to be returned and sets PSTS.STA. (D30:F0:06 bit 11)
12	<b>Received Target Abort (RTA)</b> — R/WC. 0 = No target abort. 1 = This bit is set whenever the bridge is acting as an initiator on PCI and a cycle is target-aborted on PCI. For (G)MCH/ICH8 interface packets that have completion required, this event must also cause a target abort to be returned, and sets PSTS.STA. (D30:F0:06 bit 11).
11	<b>Signaled Target Abort (STA)</b> — R/WC. 0 = No target abort. 1 = This bit is set when the bridge is acting as a target on the PCI Bus and signals a target abort.
10:9	DEVSEL# Timing (DEVT) — RO. 01h = Medium decode timing.
8	<b>Data Parity Error Detected (DPD)</b> — R/WC. 0 = Conditions described below <b>not</b> met. 1 = The ICH8 sets this bit when <b>all</b> of the following three conditions are met: <ul style="list-style-type: none"> <li>The bridge is the initiator on PCI.</li> <li>PERR# is detected asserted or a parity error is detected internally</li> <li>BCTRL.PERE (D30:F0:3E bit 0) is set.</li> </ul>
7	Fast Back to Back Capable (FBC) — RO. Hardwired to 1 to indicate that the PCI to PCI target logic is capable of receiving fast back-to-back cycles.
6	Reserved
5	66 MHz Capable (66MHZ_CAP) — RO. Hardwired to 0. This bridge is 33 MHz capable only.
4:0	Reserved



### 10.1.13 MEMBASE\_LIMIT—Memory Base and Limit Register (PCI-PCI—D30:F0)

Offset Address: 20h–23h                      Attribute: R/W, RO  
 Default Value: 00000000h                  Size: 32 bits

This register defines the base and limit, aligned to a 1-MB boundary, of the non-prefetchable memory area of the bridge. Accesses that are within the ranges specified in this register will be sent to PCI if CMD.MSE is set. Accesses from PCI that are outside the ranges specified will be accepted by the bridge if CMD.BME is set.

Bit	Description
31-20	<b>Memory Limit (ML)</b> — R/W. These bits are compared with bits 31:20 of the incoming address to determine the upper 1-MB aligned value (exclusive) of the range. The incoming address must be less than this value.
19-16	Reserved
15:4	<b>Memory Base (MB)</b> — R/W. These bits are compared with bits 31:20 of the incoming address to determine the lower 1-MB aligned value (inclusive) of the range. The incoming address must be greater than or equal to this value.
3:0	Reserved

### 10.1.14 PREF\_MEM\_BASE\_LIMIT—Prefetchable Memory Base and Limit Register (PCI-PCI—D30:F0)

Offset Address: 24h–27h                      Attribute: R/W, RO  
 Default Value: 00010001h                  Size: 32-bit

Defines the base and limit, aligned to a 1-MB boundary, of the prefetchable memory area of the bridge. Accesses that are within the ranges specified in this register will be sent to PCI if CMD.MSE is set. Accesses from PCI that are outside the ranges specified will be accepted by the bridge if CMD.BME is set.

Bit	Description
31-20	<b>Prefetchable Memory Limit (PML)</b> — R/W. These bits are compared with bits 31:20 of the incoming address to determine the upper 1-MB aligned value (exclusive) of the range. The incoming address must be less than this value.
19-16	64-bit Indicator (I64L) — RO. Indicates support for 64-bit addressing.
15:4	<b>Prefetchable Memory Base (PMB)</b> — R/W. These bits are compared with bits 31:20 of the incoming address to determine the lower 1-MB aligned value (inclusive) of the range. The incoming address must be greater than or equal to this value.
3:0	64-bit Indicator (I64B) — RO. Indicates support for 64-bit addressing.



### 10.1.15 PMBU32—Prefetchable Memory Base Upper 32 Bits Register (PCI-PCI—D30:F0)

Offset Address: 28h–2Bh                      Attribute: R/W  
Default Value: 00000000h                      Size: 32 bits

Bit	Description
31:0	<b>Prefetchable Memory Base Upper Portion (PMBU)</b> — R/W. Upper 32-bits of the prefetchable address base.

### 10.1.16 PMLU32—Prefetchable Memory Limit Upper 32 Bits Register (PCI-PCI—D30:F0)

Offset Address: 2C–2Fh                      Attribute: R/W  
Default Value: 00000000h                      Size: 32 bits

Bit	Description
31:0	<b>Prefetchable Memory Limit Upper Portion (PMLU)</b> — R/W. Upper 32-bits of the prefetchable address limit.

### 10.1.17 CAPP—Capability List Pointer Register (PCI-PCI—D30:F0)

Offset Address: 34h                              Attribute: RO  
Default Value: 50h                              Size: 8 bits

Bit	Description
7:0	Capabilities Pointer (PTR) — RO. Indicates that the pointer for the first entry in the capabilities list is at 50h in configuration space.

### 10.1.18 INTR—Interrupt Information Register (PCI-PCI—D30:F0)

Offset Address: 3Ch–3Dh                      Attribute: R/W, RO  
Default Value: 0000h                              Size: 16 bits

Bit	Description
15:8	Interrupt Pin (IPIN) — RO. The PCI bridge does not assert an interrupt.
7:0	<b>Interrupt Line (ILINE)</b> — R/W. Software written value to indicate which interrupt line (vector) the interrupt is connected to. No hardware action is taken on this register. Since the bridge does not generate an interrupt, BIOS should program this value to FFh as per the PCI bridge specification.





### 10.1.19 BCTRL—Bridge Control Register (PCI-PCI—D30:F0)

Offset Address: 3Eh–3Fh  
Default Value: 0000h

Attribute: R/WC, RO  
Size: 16 bits

Bit	Description
15:12	Reserved
11	<b>Discard Timer SERR# Enable (DTE)</b> — R/W. Controls the generation of SERR# on the primary interface in response to the DTS bit being set: 0 = Do not generate SERR# on a secondary timer discard 1 = Generate SERR# in response to a secondary timer discard
10	<b>Discard Timer Status (DTS)</b> — R/WC. This bit is set to 1 when the secondary discard timer (see the SDT bit below) expires for a delayed transaction in the hard state.
9	<b>Secondary Discard Timer (SDT)</b> — R/W. This bit sets the maximum number of PCI clock cycles that the Intel® ICH8 waits for an initiator on PCI to repeat a delayed transaction request. The counter starts once the delayed transaction data is has been returned by the system and is in a buffer in the ICH8 PCI bridge. If the master has not repeated the transaction at least once before the counter expires, the ICH8 PCI bridge discards the transaction from its queue. 0 = The PCI master timeout value is between $2^{15}$ and $2^{16}$ PCI clocks 1 = The PCI master timeout value is between $2^{10}$ and $2^{11}$ PCI clocks
8	<b>Primary Discard Timer (PDT)</b> — R/W. This bit is R/W for software compatibility only.
7	<b>Fast Back to Back Enable (FBE)</b> — RO. Hardwired to 0. The PCI logic will not generate fast back-to-back cycles on the PCI bus.
6	<b>Secondary Bus Reset (SBR)</b> — R/W. Controls PCIRST# assertion on PCI. 0 = Bridge de-asserts PCIRST# 1 = Bridge asserts PCIRST#. When PCIRST# is asserted, the delayed transaction buffers, posting buffers, and the PCI bus are initialized back to reset conditions. The rest of the part and the configuration registers are not affected.
5	<b>Master Abort Mode (MAM)</b> — R/W. Controls the ICH8 PCI bridge's behavior when a master abort occurs: Master Abort on (G)MCH/ICH8 Interconnect (DMI): 0 = Bridge asserts TRDY# on PCI. It drives all 1's for reads, and discards data on writes. 1 = Bridge returns a target abort on PCI.  Master Abort PCI (non-locked cycles): 0 = Normal completion status will be returned on the (G)MCH/ICH8 interconnect. 1 = Target abort completion status will be returned on the (G)MCH/ICH8 interconnect.  <b>NOTE:</b> All locked reads will return a completer abort completion status on the (G)MCH/ICH8 interconnect.
4	<b>VGA 16-Bit Decode (V16D)</b> — R/W. Enables the ICH8 PCI bridge to provide 16-bits decoding of VGA I/O address precluding the decode of VGA alias addresses every 1 KB. This bit requires the VGAE bit in this register be set.



Bit	Description
3	<p><b>VGA Enable (VGAE)</b> — R/W. When set to a 1, the ICH8 PCI bridge forwards the following transactions to PCI regardless of the value of the I/O base and limit registers. The transactions are qualified by CMD.MSE (D30:F0:04 bit 1) and CMD.IOSE (D30:F0:04 bit 0) being set.</p> <ul style="list-style-type: none"> <li>Memory addresses: 000A0000h-000BFFFFh</li> <li>I/O addresses: 3B0h-3BBh and 3C0h-3DFh. For the I/O addresses, bits [63:16] of the address must be 0, and bits [15:10] of the address are ignored (i.e., aliased).</li> </ul> <p>The same holds true from secondary accesses to the primary interface in reverse. That is, when the bit is 0, memory and I/O addresses on the secondary interface between the above ranges will be claimed.</p>
2	<p><b>ISA Enable (IE)</b> — R/W. This bit only applies to I/O addresses that are enabled by the I/O Base and I/O Limit registers and are in the first 64 KB of PCI I/O space. If this bit is set, the ICH8 PCI bridge will block any forwarding from primary to secondary of I/O transactions addressing the last 768 bytes in each 1-KB block (offsets 100h to 3FFh).</p>
1	<p><b>SERR# Enable (SEE)</b> — R/W. Controls the forwarding of secondary interface SERR# assertions on the primary interface. When set, the PCI bridge will forward SERR# pin.</p> <ul style="list-style-type: none"> <li>SERR# is asserted on the secondary interface.</li> <li>This bit is set.</li> <li>CMD.SEE (D30:F0:04 bit 8) is set.</li> </ul>
0	<p><b>Parity Error Response Enable (PERE)</b> — R/W.</p> <p>0 = Disable 1 = The ICH8 PCI bridge is enabled for parity error reporting based on parity errors on the PCI bus.</p>

### 10.1.20 SPDH—Secondary PCI Device Hiding Register (PCI-PCI—D30:F0)

Offset Address: 40h–41h  
Default Value: 00h

Attribute: R/W, RO  
Size: 16 bits

This register allows software to hide the PCI devices, either plugged into slots or on the motherboard.

Bit	Description
15:4	Reserved
3	<b>Hide Device 3 (HD3)</b> — R/W, RO. Same as bit 0 of this register, except for device 3 (AD[19])
2	<b>Hide Device 2 (HD2)</b> — R/W, RO. Same as bit 0 of this register, except for device 2 (AD[18])
1	<b>Hide Device 1 (HD1)</b> — R/W, RO. Same as bit 0 of this register, except for device 1 (AD[17])
0	<p><b>Hide Device 0 (HD0)</b> — R/W, RO.</p> <p>0 = The PCI configuration cycles for this slot are not affected. 1 = Intel® ICH8 hides device 0 on the PCI bus. This is done by masking the IDSEL (keeping it low) for configuration cycles to that device. Since the device will not see its IDSEL go active, it will not respond to PCI configuration cycles and the processor will think the device is not present. AD[16] is used as IDSEL for device 0.</p>



### 10.1.21 DTC—Delayed Transaction Control Register (PCI-PCI—D30:F0)

Offset Address: 44h–47h  
Default Value: 00000000h

Attribute: R/W, RO  
Size: 32 bits

Bit	Description
31	<p><b>Discard Delayed Transactions (DDT)</b> — R/W.</p> <p>0 = Logged delayed transactions are kept. 1 = The ICH8 PCI bridge will discard any delayed transactions it has logged. This includes transactions in the pending queue, and any transactions in the active queue, whether in the hard or soft DT state. The prefetchers will be disabled and return to an idle state.</p> <p><b>NOTE:</b> If a transaction is running on PCI at the time this bit is set, that transaction will continue until either the PCI master disconnects (by de-asserting FRAME#) or the PCI bridge disconnects (by asserting STOP#). This bit is cleared by the PCI bridge when the delayed transaction queues are empty and have returned to an idle state. Software sets this bit and polls for its completion</p>
30	<p><b>Block Delayed Transactions (BDT)</b> — R/W.</p> <p>0 = Delayed transactions accepted 1 = The ICH8 PCI bridge will not accept incoming transactions which will result in delayed transactions. It will blindly retry these cycles by asserting STOP#. All postable cycles (memory writes) will still be accepted.</p>
29: 8	Reserved
7: 6	<p><b>Maximum Delayed Transactions (MDT)</b> — R/W. Controls the maximum number of delayed transactions that the ICH8 PCI bridge will run. Encodings are:</p> <p>00 =) 2 Active, 5 pending 01 =) 2 active, no pending 10 =) 1 active, no pending 11 =) Reserved</p>
5	Reserved
4	<p><b>Auto Flush After Disconnect Enable (AFADE)</b> — R/W.</p> <p>0 = The PCI bridge will retain any fetched data until required to discard by producer/consumer rules. 1 = The PCI bridge will flush any prefetched data after either the PCI master (by de-asserting FRAME#) or the PCI bridge (by asserting STOP#) disconnects the PCI transfer.</p>
3	<p><b>Never Prefetch (NP)</b> — R/W.</p> <p>0 = Prefetch enabled 1 = The ICH8 will only fetch a single DW and will not enable prefetching, regardless of the command being an Memory read (MR), Memory read line (MRL), or Memory read multiple (MRM).</p>



Bit	Description
2	<b>Memory Read Multiple Prefetch Disable (MRMPD)</b> — R/W. 0 = MRM commands will fetch multiple cache lines as defined by the prefetch algorithm. 1 = Memory read multiple (MRM) commands will fetch only up to a single, 64-byte aligned cache line.
1	<b>Memory Read Line Prefetch Disable (MRLPD)</b> — R/W. 0 = MRL commands will fetch multiple cache lines as defined by the prefetch algorithm. 1 = Memory read line (MRL) commands will fetch only up to a single, 64-byte aligned cache line.
0	<b>Memory Read Prefetch Disable (MRPD)</b> — R/W. 0 = MR commands will fetch up to a 64-byte aligned cache line. 1 = Memory read (MR) commands will fetch only a single DW.

### 10.1.22 BPS—Bridge Proprietary Status Register (PCI-PCI—D30:F0)

Offset Address: 48h–4Bh  
Default Value: 00000000h

Attribute: R/WC, RO  
Size: 32 bits

Bit	Description
31:17	Reserved
16	<b>PERR# Assertion Detected (PAD)</b> — R/WC. This bit is set by hardware whenever the PERR# pin is asserted on the rising edge of PCI clock. This includes cases in which the chipset is the agent driving PERR#. It remains asserted until cleared by software writing a 1 to this location. When enabled by the PERR#-to-SERR# Enable bit (in the Bridge Policy Configuration register), a 1 in this bit can generate an internal SERR# and be a source for the NMI logic. This bit can be used by software to determine the source of a system problem.
15:7	Reserved
6:4	<b>Number of Pending Transactions (NPT)</b> — RO. This read-only indicator tells debug software how many transactions are in the pending queue. Possible values are: 000 = No pending transaction 001 = 1 pending transaction 010 = 2 pending transactions 011 = 3 pending transactions 100 = 4 pending transactions 101 = 5 pending transactions 110 - 111 = Reserved <b>NOTE:</b> This field is not valid if DTC.MDT (offset 44h:bits 7:6) is any value other than '00'.
3:2	Reserved
1:0	<b>Number of Active Transactions (NAT)</b> — RO. This read-only indicator tells debug software how many transactions are in the active queue. Possible values are: 00 = No active transactions 01 = 1 active transaction 10 = 2 active transactions 11 = Reserved



### 10.1.23 BPC—Bridge Policy Configuration Register (PCI-PCI—D30:F0)

Offset Address: 4Ch–4Fh  
Default Value: 00001200h

Attribute: R/W, RO  
Size: 32 bits

Bit	Description																				
31:14	Reserved																				
13:8	<p><b>Upstream Read Latency Threshold (URLT)</b> — R/W: This field specifies the number of PCI clocks after internally enqueueing an upstream memory read request at which point the PCI target logic should insert wait states in order to optimize lead-off latency. When the master returns after this threshold has been reached and data has not arrived in the Delayed Transaction completion queue, then the PCI target logic will insert wait states instead of immediately retrying the cycle. The PCI target logic will insert up to 16 clocks of target initial latency (from FRAME# assertion to TRDY# or STOP# assertion) before retrying the PCI read cycle (if the read data has not arrived yet).</p> <p>Note that the starting event for this Read Latency Timer is not explicitly visible externally.</p> <p>A value of 0h disables this policy completely such that wait states will never be inserted on the read lead-off data phase.</p> <p>The default value (12h) specifies 18 PCI clocks (540 ns) and is approximately 4 clocks less than the typical idle lead-off latency expected for desktop ICH8 systems. This value may need to be changed by BIOS, depending on the platform.</p>																				
7	<p><b>Subtractive Decode Policy (SDP)</b> — R/W.</p> <p>0 = The PCI bridge always forwards memory and I/O cycles that are not claimed by any other device on the backbone (primary interface) to the PCI bus (secondary interface).</p> <p>1 = The PCI bridge will not claim and forward memory or I/O cycles at all unless the corresponding Space Enable bit is set in the Command register.</p> <p><b>NOTE:</b> The Boot BIOS Destination Selection strap can force the BIOS accesses to PCI.</p> <table border="1"> <thead> <tr> <th>CMD.MSE</th> <th>BPC.SDP</th> <th>Range</th> <th>Forwarding Policy</th> </tr> </thead> <tbody> <tr> <td>0</td> <td>0</td> <td>Don't Care</td> <td>Forward unclaimed cycles</td> </tr> <tr> <td>0</td> <td>1</td> <td>Don't Care</td> <td>Forwarding Prohibited</td> </tr> <tr> <td>1</td> <td>X</td> <td>Within range</td> <td>Positive decode and forward</td> </tr> <tr> <td>1</td> <td>X</td> <td>Outside</td> <td>Subtractive decode &amp; forward</td> </tr> </tbody> </table>	CMD.MSE	BPC.SDP	Range	Forwarding Policy	0	0	Don't Care	Forward unclaimed cycles	0	1	Don't Care	Forwarding Prohibited	1	X	Within range	Positive decode and forward	1	X	Outside	Subtractive decode & forward
CMD.MSE	BPC.SDP	Range	Forwarding Policy																		
0	0	Don't Care	Forward unclaimed cycles																		
0	1	Don't Care	Forwarding Prohibited																		
1	X	Within range	Positive decode and forward																		
1	X	Outside	Subtractive decode & forward																		
6	<p><b>PERR#-to-SERR# Enable (PSE)</b> — R/W. When this bit is set, a 1 in the PERR# Assertion status bit (in the Bridge Proprietary Status register) will result in an internal SERR# assertion on the primary side of the bridge (if also enabled by the SERR# Enable bit in the primary Command register). SERR# is a source of NMI.</p>																				
5	<p><b>Secondary Discard Timer Testmode (SDTT)</b> — R/W.</p> <p>0 = The secondary discard timer expiration will be defined in BCTRL.SDT (D30:F0:3E, bit 9)</p> <p>1 = The secondary discard timer will expire after 128 PCI clocks.</p>																				
4:3	Reserved																				



Bit	Description
2	<b>Peer Decode Enable (PDE)</b> — R/W. 0 = The PCI bridge assumes that all memory cycles target main memory, and all I/O cycles are not claimed. 1 = The PCI bridge will perform peer decode on any memory or I/O cycle from PCI that falls outside of the memory and I/O window registers
1	Reserved
0	<b>Received Target Abort SERR# Enable (RTAE)</b> — R/W. When set, the PCI bridge will report SERR# when PSTS.RTA (D30:F0:06 bit 12) or SSTS.RTA (D30:F0:1E bit 12) are set, and CMD.SEE (D30:F0:04 bit 8) is set.

#### 10.1.24 SVCAP—Subsystem Vendor Capability Register (PCI-PCI—D30:F0)

Offset Address: 50h–51h                      Attribute: RO  
Default Value: 000Dh                      Size: 16 bits

Bit	Description
15:8	<b>Next Capability (NEXT)</b> — RO. Value of 00h indicates this is the last item in the list.
7:0	<b>Capability Identifier (CID)</b> — RO. Value of 0Dh indicates this is a PCI bridge subsystem vendor capability.

#### 10.1.25 SVID—Subsystem Vendor IDs Register (PCI-PCI—D30:F0)

Offset Address: 54h–57h                      Attribute: R/WO  
Default Value: 00000000h                      Size: 32 bits

Bit	Description
31:16	<b>Subsystem Identifier (SID)</b> — R/WO. Indicates the subsystem as identified by the vendor. This field is write once and is locked down until a bridge reset occurs (not the PCI bus reset).
15:0	<b>Subsystem Vendor Identifier (SVID)</b> — R/WO. Indicates the manufacturer of the subsystem. This field is write once and is locked down until a bridge reset occurs (not the PCI bus reset).





# 11 IDE Controller Registers (D31:F1) (Mobile Only)

## 11.1 PCI Configuration Registers (IDE—D31:F1)

**Note:** Address locations that are not shown should be treated as Reserved (See Section 6.2 for details).

All of the IDE registers are in the core well. None of the registers can be locked.

**Table 119. IDE Controller PCI Register Address Map (IDE-D31:F1)**

Offset	Mnemonic	Register Name	Default	Type
00h–01h	VID	Vendor Identification	8086h	RO
02h–03h	DID	Device Identification	See register description	RO
04h–05h	PCICMD	PCI Command	00h	R/W, RO
06h–07h	PCISTS	PCI Status	0280h	R/W, RO
08h	RID	Revision Identification	See register description	RO
09h	PI	Programming Interface	8Ah	R/W, RO
0Ah	SCC	Sub Class Code	01h	RO
0Bh	BCC	Base Class Code	01h	RO
0Ch	CLS	Cache Line Size	00h	RO
0Dh	PMLT	Primary Master Latency Timer	00h	RO
10h–13h	PCMD_BAR	Primary Command Block Base Address	00000001h	R/W, RO
14h–17h	PCNL_BAR	Primary Control Block Base Address	00000001h	R/W, RO
18h–1Bh	SCMD_BAR	Secondary Command Block Base Address	00000001h	R/W, RO
1Ch–1Fh	SCNL_BAR	Secondary Control Block Base Address	00000001h	R/W, RO
20h–23h	BM_BASE	Bus Master Base Address	00000001h	R/W, RO
2Ch–2Dh	IDE_SVID	Subsystem Vendor ID	00h	R/WO
2Eh–2Fh	IDE_SID	Subsystem ID	0000h	R/WO
3C	INTR_LN	Interrupt Line	00h	R/W
3D	INTR_PN	Interrupt Pin	See register description	RO
40h–41h	IDE_TIMP	Primary IDE Timing	0000h	R/W
42h–43h	IDE_TIMS	Secondary IDE Timing	0000h	R/W
44h	SLV_IDETIM	Slave IDE Timing	00h	R/W
48h	SDMA_CNT	Synchronous DMA Control	00h	R/W
4Ah–4Bh	SDMA_TIM	Synchronous DMA Timing	0000h	R/W
54h	IDE_CONFIG	IDE I/O Configuration	00000000h	R/W
C0h	ATC	APM Trapping Control	00h	R/W
C4h	ATS	APM Trapping Status	00h	R/WC

**NOTE:** The ICH8M IDE controller is not arbitrated as a PCI device; therefore, it does not need a master latency timer.



### 11.1.1 VID—Vendor Identification Register (IDE—D31:F1)

Offset Address:	00h–01h	Attribute:	RO
Default Value:	8086h	Size:	16-bit
Lockable:	No	Power Well:	Core

Bit	Description
15:0	Vendor ID — RO. This is a 16-bit value assigned to Intel. Intel VID = 8086h

### 11.1.2 DID—Device Identification Register (IDE—D31:F1)

Offset Address:	02h–03h	Attribute:	RO
Default Value:	See bit description	Size:	16-bit
Lockable:	No	Power Well:	Core

Bit	Description
15:0	Device ID — RO. This is a 16-bit value assigned to the Intel® ICH8M IDE controller. Refer to the <i>Intel ICH8 ICH8M Family EDS Specification Update</i> for the value of the Device ID Register.







### 11.1.4 PCISTS — PCI Status Register (IDE—D31:F1)

Address Offset: 06h–07h                      Attribute: R/WC, RO  
 Default Value: 0280h                      Size: 16 bits

**Note:** For the writable bits, software must write a 1 to clear bits that are set. Writing a 0 to the bit has no effect.

Bit	Description
15	Detected Parity Error (DPE) — RO. Reserved as 0.
14	Signaled System Error (SSE) — RO. Reserved as 0.
13	<b>Received Master Abort (RMA)</b> — R/WC. 0 = Master abort Not generated by Bus Master IDE interface function. 1 = Bus Master IDE interface function, as a master, generated a master abort.
12	Reserved as 0 — RO.
11	Reserved as 0 — RO.
10:9	<b>DEVSEL# Timing Status (DEV_STS)</b> — RO. 01 = Hardwired; however, the ICH8M does not have a real DEVSEL# signal associated with the IDE unit, so these bits have no effect.
8	Data Parity Error Detected (DPED) — RO. Reserved as 0.
7	Fast Back to Back Capable (FB2BC) — RO. Reserved as 1.
6	User Definable Features (UDF) — RO. Reserved as 0.
5	66MHz Capable (66MHZ_CAP) — RO. Reserved as 0.
4	Reserved
3	<b>Interrupt Status (INTS)</b> — RO. This bit is independent of the state of the Interrupt Disable bit in the command register. 0 = Interrupt is cleared. 1 = Interrupt/MSI is asserted.
2:0	Reserved



### 11.1.5 RID—Revision Identification Register (IDE—D31:F1)

Offset Address: 08h Attribute: RO  
 Default Value: See bit description Size: 8 bits

Bit	Description
7:0	Revision ID — RO. Refer to the <i>Intel® I/O Controller Hub 8 (ICH8) Family Specification Update</i> for the value of the Revision ID Register

### 11.1.6 PI—Programming Interface Register (IDE—D31:F1)

Address Offset: 09h Attribute: RO, R/W  
 Default Value: 8Ah Size: 8 bits

Bit	Description
7	This read-only bit is a 1 to indicate that the ICH8M supports bus master operation
6:4	Reserved. Hardwired to 000b.
3	<b>SOP_MODE_CAP</b> — RO. This read-only bit is a 1 to indicate that the secondary controller supports both legacy and native modes.
2	<b>SOP_MODE_SEL</b> — R/W. This read/write bit determines the mode that the secondary IDE channel is operating in. 0 = Legacy-PCI mode (default) 1 = Native-PCI mode
1	<b>POP_MODE_CAP</b> — RO. This read-only bit is a 1 to indicate that the primary controller supports both legacy and native modes.
0	<b>POP_MODE_SEL</b> — R/W. This read/write bits determines the mode that the primary IDE channel is operating in. 0 = Legacy-PCI mode (default) 1 = Native-PCI mode

### 11.1.7 SCC—Sub Class Code Register (IDE—D31:F1)

Address Offset: 0Ah Attribute: RO  
 Default Value: 01h Size: 8 bits

Bit	Description
7:0	Sub Class Code (SCC) — RO. 01h = IDE device, in the context of a mass storage device.





### 11.1.12 PCNL\_BAR—Primary Control Block Base Address Register (IDE—D31:F1)

Address Offset: 14h–17h                      Attribute: R/W, RO  
 Default Value: 00000001h                      Size: 32 bits

Bit	Description
31:16	Reserved
15:2	<b>Base Address</b> — R/W. Base address of the I/O space (4 consecutive I/O locations).
1	Reserved
0	Resource Type Indicator (RTE) — RO. Hardwired to 1 indicating a request for I/O space.

**NOTE:** This 4-byte I/O space is used in native mode for the Primary Controller's Command Block.

### 11.1.13 SCMD\_BAR—Secondary Command Block Base Address Register (IDE D31:F1)

Address Offset: 18h–1Bh                      Attribute: R/W, RO  
 Default Value: 00000001h                      Size: 32 bits

Bit	Description
31:16	Reserved
15:3	<b>Base Address</b> — R/W. Base address of the I/O space (8 consecutive I/O locations).
2:1	Reserved
0	Resource Type Indicator (RTE) — RO. Hardwired to 1 indicating a request for I/O space.

**NOTE:** This 4-byte I/O space is used in native mode for the Secondary Controller's Command Block.

### 11.1.14 SCNL\_BAR—Secondary Control Block Base Address Register (IDE D31:F1)

Address Offset: 1Ch–1Fh                      Attribute: R/W, RO  
 Default Value: 00000001h                      Size: 32 bits

Bit	Description
31:16	Reserved
15:2	<b>Base Address</b> — R/W. Base address of the I/O space (4 consecutive I/O locations).
1	Reserved
0	Resource Type Indicator (RTE) — RO. Hardwired to 1 indicating a request for I/O space.

**NOTE:** This 4-byte I/O space is used in native mode for the Secondary Controller's Command Block.





### 11.1.18 INTR\_LN—Interrupt Line Register (IDE—D31:F1)

Address Offset: 3Ch Attribute: R/W  
 Default Value: 00h Size: 8 bits

Bit	Description
7:0	<b>Interrupt Line (INT_LN)</b> — R/W. This field is used to communicate to software the interrupt line that the interrupt pin is connected to.

### 11.1.19 INTR\_PN—Interrupt Pin Register (IDE—D31:F1)

Address Offset: 3Dh Attribute: RO  
 Default Value: See Register Description Size: 8 bits

Bit	Description
7:0	<b>Interrupt Pin</b> — RO. This reflects the value of D31IP.PIP (Chipset Config Registers: Offset 3100h: bits 7:4).

### 11.1.20 IDE\_TIMP — IDE Primary Timing Register (IDE—D31:F1)

Address Offset: 40–41h Attribute: R/W  
 Default Value: 0000h Size: 16 bits

This register controls the timings driven on the IDE cable for PIO and 8237 style DMA transfers. It also controls operation of the buffer for PIO transfers.

Bit	Description
15	<b>IDE Decode Enable (IDE)</b> — R/W. The IDE I/O Space Enable bit (D31:F1:04h, bit 0) in the Command register must be set in order for this bit to have any effect. 0 = Disable. 1 = Enables the ICH8M to decode the Command (1F0–1F7h) and Control (3F6h) Blocks.  This bit also effects the memory decode range for IDE Expansion.
14	<b>Drive 1 Timing Register Enable (SITRE)</b> — R/W. 0 = Use bits 13:12, 9:8 for both drive 0 and drive 1. 1 = Use bits 13:12, 9:8 for drive 0, and use the Slave IDE Timing register for drive 1
13:12	<b>IORDY Sample Point (ISP)</b> — R/W. The setting of these bits determine the number of PCI clocks between IDE IOR#/IOW# assertion and the first IORDY sample point. 00 = 5 clocks 01 = 4 clocks 10 = 3 clocks 11 = Reserved
11:10	Reserved
9:8	<b>Recovery Time (RCT)</b> — R/W. The setting of these bits determines the minimum number of PCI clocks between the last IORDY sample point and the IOR#/IOW# strobe of the next cycle. 00 = 4 clocks 01 = 3 clocks 10 = 2 clocks 11 = 1 clock



Bit	Description
7	<b>Drive 1 DMA Timing Enable (DTE1)</b> — R/W. 0 = Disable. 1 = Enable the fast timing mode for DMA transfers only for this drive. PIO transfers to the IDE data port will run in compatible timing.
6	<b>Drive 1 Prefetch/Posting Enable (PPE1)</b> — R/W. 0 = Disable. 1 = Enable Prefetch and posting to the IDE data port for this drive.
5	<b>Drive 1 IORDY Sample Point Enable (IE1)</b> — R/W. 0 = Disable IORDY sampling for this drive. 1 = Enable IORDY sampling for this drive.
4	<b>Drive 1 Fast Timing Bank (TIME1)</b> — R/W. 0 = Accesses to the data port will use compatible timings for this drive. 1 = When this bit = 1 and bit 14 = 0, accesses to the data port will use bits 13:12 for the IORDY sample point, and bits 9:8 for the recovery time. When this bit = 1 and bit 14 = 1, accesses to the data port will use the IORDY sample point and recover time specified in the slave IDE timing register.
3	<b>Drive 0 DMA Timing Enable (DTE0)</b> — R/W. 0 = Disable 1 = Enable fast timing mode for DMA transfers only for this drive. PIO transfers to the IDE data port will run in compatible timing.
2	<b>Drive 0 Prefetch/Posting Enable (PPE0)</b> — R/W. 0 = Disable prefetch and posting to the IDE data port for this drive. 1 = Enable prefetch and posting to the IDE data port for this drive.
1	<b>Drive 0 IORDY Sample Point Enable (IE0)</b> — R/W. 0 = Disable IORDY sampling is disabled for this drive. 1 = Enable IORDY sampling for this drive.
0	<b>Drive 0 Fast Timing Bank (TIME0)</b> — R/W. 0 = Accesses to the data port will use compatible timings for this drive. 1 = Accesses to the data port will use bits 13:12 for the IORDY sample point, and bits 9:8 for the recovery time





### 11.1.21 IDE\_TIMS — IDE Secondary Timing Register (IDE–D31:F1)

Address Offset: 42h–43h                      Attribute: R/W  
 Default Value: 0000h                      Size: 16 bits

Bit	Description
15	<b>IDE Decode Enable (IDE)</b> — R/W. This bit enables/disables the Secondary decode. The IDE I/O Space Enable bit (D31:F1:04h, bit 0) in the Command register must be set in order for this bit to have any effect. Additionally, separate configuration bits are provided (in the IDE I/O Configuration register) to individually disable the secondary IDE interface signals, even if the IDE Decode Enable bit is set. 0 = Disable. 1 = Enables the ICH8M to decode the associated Command Blocks (170–177h) and Control Block (376h). Accesses to these ranges return 00h, as the secondary channel is not implemented.
14:12	No Operation (NOP) — R/W. These bits are read/write for legacy software compatibility, but have no functionality in the ICH8M since a secondary channel does not exist.
11	Reserved
10:0	No Operation (NOP) — R/W. These bits are read/write for legacy software compatibility, but have no functionality in the ICH8M since a secondary channel does not exist.

### 11.1.22 SLV\_IDETIM—Slave (Drive 1) IDE Timing Register (IDE–D31:F1)

Address Offset: 44h                              Attribute: R/W  
 Default Value: 00h                              Size: 8 bits

Bit	Description
7:4	No Operation (NOP) — R/W. These bits are read/write for legacy software compatibility, but have no functionality in the ICH8M.
3:2	<b>Primary Drive 1 IORDY Sample Point (PISP1)</b> — R/W. This field determines the number of PCI clocks between IOR#/IOW# assertion and the first IORDY sample point, if the access is to drive 1 data port and bit 14 of the IDE timing register for primary is set. 00 = 5 clocks 01 = 4 clocks 10 = 3 clocks 11 = Reserved
1:0	<b>Primary Drive 1 Recovery Time (PRCT1)</b> — R/W. This field determines the minimum number of PCI clocks between the last IORDY sample point and the IOR#/IOW# strobe of the next cycle, if the access is to drive 1 data port and bit 14 of the IDE timing register for primary is set. 00 = 4 clocks 01 = 3 clocks 10 = 2 clocks 11 = 1 clocks



### 11.1.23 SDMA\_CNT—Synchronous DMA Control Register (IDE—D31:F1)

Address Offset: 48h  
Default Value: 00h

Attribute: R/W  
Size: 8 bits

Bit	Description
7:4	Reserved
3:2	No Operation (NOP) — R/W. These bits are read/write for legacy software compatibility, but have no functionality in the ICH8M.
1	<b>Primary Drive 1 Synchronous DMA Mode Enable (PSDE1)</b> — R/W. 0 = Disable (default) 1 = Enable Synchronous DMA mode for primary channel drive 1.
0	<b>Primary Drive 0 Synchronous DMA Mode Enable (PSDE0)</b> — R/W. 0 = Disable (default) 1 = Enable Synchronous DMA mode for primary channel drive 0.



### 11.1.24 SDMA\_TIM—Synchronous DMA Timing Register (IDE—D31:F1)

Address Offset: 4Ah–4Bh  
Default Value: 0000h

Attribute: R/W  
Size: 16 bits

**Note:** For FAST\_PCB1 = 1 (133 MHz clk) in bits [13:12, 9:8, 5:4, 1:0], refer to [Section 5.15.4](#) for details.

Bit	Description																				
15:14	Reserved																				
13:12	No Operation (NOP) — R/W. These bits are read/write for legacy software compatibility, but have no functionality in the ICH8M.																				
11:10	Reserved																				
9:8	No Operation (NOP) — R/W. These bits are read/write for legacy software compatibility, but have no functionality in the ICH8M.																				
7:6	Reserved																				
5:4	<p><b>Primary Drive 1 Cycle Time (PCT1)</b> — R/W. For Ultra ATA mode, the setting of these bits determines the minimum write strobe cycle time (CT). The DMARDY#-to-STOP (RP) time is also determined by the setting of these bits.</p> <table border="1"> <thead> <tr> <th></th> <th>PCB1 = 0 (33 MHz clk)</th> <th>PCB1 = 1 (66 MHz clk)</th> <th>FAST_PCB1 = 1 (133 MHz clk)</th> </tr> </thead> <tbody> <tr> <td>00</td> <td>CT 4 clocks, RP 6 clocks</td> <td>00 = Reserved</td> <td>00 = Reserved</td> </tr> <tr> <td>01</td> <td>CT 3 clocks, RP 5 clocks</td> <td>01 = CT 3 clocks, RP 8 clocks</td> <td>01 = CT 3 clocks, RP 16 clocks</td> </tr> <tr> <td>10</td> <td>CT 2 clocks, RP 4 clocks</td> <td>10 = CT 2 clocks, RP 8 clocks</td> <td>10 = Reserved</td> </tr> <tr> <td>11</td> <td>11 = Reserved</td> <td>11 = Reserved</td> <td>11 = Reserved</td> </tr> </tbody> </table>		PCB1 = 0 (33 MHz clk)	PCB1 = 1 (66 MHz clk)	FAST_PCB1 = 1 (133 MHz clk)	00	CT 4 clocks, RP 6 clocks	00 = Reserved	00 = Reserved	01	CT 3 clocks, RP 5 clocks	01 = CT 3 clocks, RP 8 clocks	01 = CT 3 clocks, RP 16 clocks	10	CT 2 clocks, RP 4 clocks	10 = CT 2 clocks, RP 8 clocks	10 = Reserved	11	11 = Reserved	11 = Reserved	11 = Reserved
	PCB1 = 0 (33 MHz clk)	PCB1 = 1 (66 MHz clk)	FAST_PCB1 = 1 (133 MHz clk)																		
00	CT 4 clocks, RP 6 clocks	00 = Reserved	00 = Reserved																		
01	CT 3 clocks, RP 5 clocks	01 = CT 3 clocks, RP 8 clocks	01 = CT 3 clocks, RP 16 clocks																		
10	CT 2 clocks, RP 4 clocks	10 = CT 2 clocks, RP 8 clocks	10 = Reserved																		
11	11 = Reserved	11 = Reserved	11 = Reserved																		
3:2	Reserved																				
1:0	<p><b>Primary Drive 0 Cycle Time (PCT0)</b> — R/W. For Ultra ATA mode, the setting of these bits determines the minimum write strobe cycle time (CT). The DMARDY#-to-STOP (RP) time is also determined by the setting of these bits.</p> <table border="1"> <thead> <tr> <th></th> <th>PCB1 = 0 (33 MHz clk)</th> <th>PCB1 = 1 (66 MHz clk)</th> <th>FAST_PCB1 = 1 (133 MHz clk)</th> </tr> </thead> <tbody> <tr> <td>00</td> <td>CT 4 clocks, RP 6 clocks</td> <td>00 = Reserved</td> <td>00 = Reserved</td> </tr> <tr> <td>01</td> <td>CT 3 clocks, RP 5 clocks</td> <td>01 = CT 3 clocks, RP 8 clocks</td> <td>01 = CT 3 clocks, RP 16 clocks</td> </tr> <tr> <td>10</td> <td>CT 2 clocks, RP 4 clocks</td> <td>10 = CT 2 clocks, RP 8 clocks</td> <td>10 = Reserved</td> </tr> <tr> <td>11</td> <td>11 = Reserved</td> <td>11 = Reserved</td> <td>11 = Reserved</td> </tr> </tbody> </table>		PCB1 = 0 (33 MHz clk)	PCB1 = 1 (66 MHz clk)	FAST_PCB1 = 1 (133 MHz clk)	00	CT 4 clocks, RP 6 clocks	00 = Reserved	00 = Reserved	01	CT 3 clocks, RP 5 clocks	01 = CT 3 clocks, RP 8 clocks	01 = CT 3 clocks, RP 16 clocks	10	CT 2 clocks, RP 4 clocks	10 = CT 2 clocks, RP 8 clocks	10 = Reserved	11	11 = Reserved	11 = Reserved	11 = Reserved
	PCB1 = 0 (33 MHz clk)	PCB1 = 1 (66 MHz clk)	FAST_PCB1 = 1 (133 MHz clk)																		
00	CT 4 clocks, RP 6 clocks	00 = Reserved	00 = Reserved																		
01	CT 3 clocks, RP 5 clocks	01 = CT 3 clocks, RP 8 clocks	01 = CT 3 clocks, RP 16 clocks																		
10	CT 2 clocks, RP 4 clocks	10 = CT 2 clocks, RP 8 clocks	10 = Reserved																		
11	11 = Reserved	11 = Reserved	11 = Reserved																		



### 11.1.25 IDE\_CONFIG—IDE I/O Configuration Register (IDE—D31:F1)

Address Offset: 54h  
 Default Value: 00000000h

Attribute: R/W  
 Size: 32 bits

Bit	Description
31:24	Reserved
23:20	<b>Miscellaneous Scratchpad (MS)</b> — R/W. Previously defined as a scratchpad bit to indicate to a driver that ATA-100 is supported. This is not used by software as all they needed to know was located in bits 7:4. See the definition of those bits.
19:18	No Operation (NOP) — R/W. These bits are read/write for legacy software compatibility, but have no functionality in the ICH8M.
17:16	<b>SIG_MODE</b> — R/W. These bits are used to control mode of the IDE signal pins for swap bay support. If the PRS bit (Chipset Config Registers: Offset 3414h: bit 1) is 1, the reset states of bits 17:16 will be 01 (tri-state) instead of 00 (normal). 00 = Normal (Enabled) 01 = Tri-state (Disabled) 10 = Drive low (Disabled) 11 = Reserved
15:14	No Operation (NOP) — R/W. These bits are read/write for legacy software compatibility, but have no functionality in the ICH8M.
13	<b>Fast Primary Drive 1 Base Clock (FAST_PCB1)</b> — R/W. This bit is used in conjunction with the PCT1 bits to enable/disable Ultra ATA/100 timings for the Primary Slave drive. 0 = Disable Ultra ATA/100 timing for the Primary Slave drive. 1 = Enable Ultra ATA/100 timing for the Primary Slave drive (overrides bit 1 in this register).
12	<b>Fast Primary Drive 0 Base Clock (FAST_PCB0)</b> — R/W. This bit is used in conjunction with the PCT0 bits to enable/disable Ultra ATA/100 timings for the Primary Master drive. 0 = Disable Ultra ATA/100 timing for the Primary Master drive. 1 = Enable Ultra ATA/100 timing for the Primary Master drive (overrides bit 0 in this register).
11:8	Reserved
7	No Operation (NOP) — R/W. These bits are read/write for legacy software compatibility, but have no functionality in the ICH8M.
6	No Operation (NOP) — R/W. These bits are read/write for legacy software compatibility, but have no functionality in the ICH8M.
5	<b>Primary Slave Channel Cable Reporting</b> — R/W. BIOS should program this bit to tell the IDE driver which cable is plugged into the channel. 0 = 40 conductor cable is present. 1 = 80 conductor cable is present.
4	<b>Primary Master Channel Cable Reporting</b> — R/W. Same description as bit 5
3:2	No Operation (NOP) — R/W. These bits are read/write for legacy software compatibility, but have no functionality in the ICH8M.
1	<b>Primary Drive 1 Base Clock (PCB1)</b> — R/W. 0 = 33 MHz base clock for Ultra ATA timings. 1 = 66 MHz base clock for Ultra ATA timings
0	<b>Primary Drive 0 Base Clock (PCB0)</b> — R/W. 0 = 33 MHz base clock for Ultra ATA timings. 1 = 66 MHz base clock for Ultra ATA timings





## 11.2 Bus Master IDE I/O Registers (IDE—D31:F1)

The bus master IDE function uses 16 bytes of I/O space, allocated via the BMIBA register, located in Device 31:Function 1 Configuration space, offset 20h. All bus master IDE I/O space registers can be accessed as byte, word, or dword quantities. Reading reserved bits returns an indeterminate, inconsistent value, and writes to reserved bits have no affect (but should not be attempted). The description of the I/O registers is shown in Table 120.

Table 120. Bus Master IDE I/O Registers

BMIBASE + Offset	Mnemonic	Register Name	Default	Type
00	BMICP	Bus Master IDE Command Primary	00h	R/W
01	—	Reserved	00h	RO
02	BMISP	Bus Master IDE Status Primary	00h	R/W, R/WC
03	—	Reserved	00h	RO
04–07	BMIDP	Bus Master IDE Descriptor Table Pointer Primary	xxxxxxxxh	R/W

### 11.2.1 BMICP—Bus Master IDE Command Register (IDE—D31:F1)

Address Offset: BMIBASE + 00h      Attribute: R/W  
 Default Value: 00h      Size: 8 bits

Bit	Description
7:4	Reserved. Returns 0.
3	<b>Read / Write Control (R/WC)</b> — R/W. This bit sets the direction of the bus master transfer: This bit must NOT be changed when the bus master function is active. 0 = Memory reads 1 = Memory writes
2:1	Reserved. Returns 0.
0	<b>Start/Stop Bus Master (START)</b> — R/W. 0 = All state information is lost when this bit is cleared. Master mode operation cannot be stopped and then resumed. If this bit is reset while bus master operation is still active (i.e., the Bus Master IDE Active bit (BMIBASE + 02h, bit 0) of the Bus Master IDE Status register for that IDE channel is set) and the drive has not yet finished its data transfer (the Interrupt bit (BMIBASE + 02h, bit 2) in the Bus Master IDE Status register for that IDE channel is not set), the bus master command is said to be aborted and data transferred from the drive may be discarded instead of being written to system memory. 1 = Enables bus master operation of the controller. Bus master operation does not actually start unless the Bus Master Enable bit (D31:F1:04h, bit 2) in PCI configuration space is also set. Bus master operation begins when this bit is detected changing from 0 to 1. The controller will transfer data between the IDE device and memory only when this bit is set. Master operation can be halted by writing a 0 to this bit.  <b>NOTE:</b> This bit is intended to be cleared by software after the data transfer is completed, as indicated by either the Bus Master IDE Active bit being cleared or the Interrupt bit of the Bus Master IDE Status register for that IDE channel being set, or both. Hardware does not clear this bit automatically.



### 11.2.2 BMISP—Bus Master IDE Status Register (IDE—D31:F1)

Address Offset: BMIBASE + 02h                      Attribute: R/W, R/WC  
 Default Value: 00h                                      Size: 8 bits

Bit	Description
7	<b>PRD Interrupt Status (PRDIS) — R/WC.</b> 0 = When this bit is cleared by software, the interrupt is cleared. 1 = Set when the host controller completes execution of a PRD that has its Interrupt bit (bit 2 of this register) set.
6	<b>Drive 1 DMA Capable — R/W.</b> 0 = Not Capable. 1 = Capable. Set by device dependent code (BIOS or device driver) to indicate that drive 1 for this channel is capable of DMA transfers, and that the controller has been initialized for optimum performance. The ICH8M does not use this bit. It is intended for systems that do not attach BMIDE to the PCI bus.
5	<b>Drive 0 DMA Capable — R/W.</b> 0 = Not Capable 1 = Capable. Set by device dependent code (BIOS or device driver) to indicate that drive 0 for this channel is capable of DMA transfers, and that the controller has been initialized for optimum performance. The ICH8M does not use this bit. It is intended for systems that do not attach BMIDE to the PCI bus.
4:3	Reserved. Returns 0.
2	<b>Interrupt — R/WC.</b> Software can use this bit to determine if an IDE device has asserted its interrupt line (IDEIRQ). 0 = Software clears this bit by writing a 1 to it. If this bit is cleared while the interrupt is still active, this bit will remain clear until another assertion edge is detected on the interrupt line. 1 = Set by the rising edge of the IDE interrupt line, regardless of whether or not the interrupt is masked in the 8259 or the internal I/O APIC. When this bit is read as 1, all data transferred from the drive is visible in system memory.
1	<b>Error — R/WC.</b> 0 = Software clears this bit by writing a 1 to it. 1 = This bit is set when the controller encounters a target abort or master abort when transferring data on PCI.
0	<b>Bus Master IDE Active (ACT) — RO.</b> 0 = This bit is cleared by the ICH8M when the last transfer for a region is performed, where EOT for that region is set in the region descriptor. It is also cleared by the ICH8M when the Start bit is cleared in the Command register. When this bit is read as 0, all data transferred from the drive during the previous bus master command is visible in system memory, unless the bus master command was aborted. 1 = Set by the ICH8M when the Start bit is written to the Command register.

### 11.2.3 BMIDP—Bus Master IDE Descriptor Table Pointer Register (IDE—D31:F1)

Address Offset: BMIBASE + 04h                      Attribute: R/W  
 Default Value: All bits undefined                      Size: 32 bits

Bit	Description
31:2	<b>Address of Descriptor Table (ADDR) — R/W.</b> Corresponds to A[31:2]. The Descriptor Table must be dword-aligned. The Descriptor Table must not cross a 64-K boundary in memory.
1:0	Reserved

## § §







# 12 SATA Controller Registers (D31:F2)

## 12.1 PCI Configuration Registers (SATA–D31:F2)

**Note:** Address locations that are not shown should be treated as Reserved.

All of the SATA registers are in the core well. None of the registers can be locked.

**Table 121. SATA Controller PCI Register Address Map (SATA–D31:F2) (Sheet 1 of 2)**

Offset	Mnemonic	Register Name	Default	Type
00h–01h	VID	Vendor Identification	8086h	RO
02h–03h	DID	Device Identification	See register description	RO
04h–05h	PCICMD	PCI Command	0000h	R/W, RO
06h–07h	PCISTS	PCI Status	02B0h	R/WC, RO
08h	RID	Revision Identification	See register description	RO
09h	PI	Programming Interface	See register description	See register description
0Ah	SCC	Sub Class Code	See register description	See register description
0Bh	BCC	Base Class Code	01h	RO
0Dh	PMLT	Primary Master Latency Timer	00h	RO
10h–13h	PCMD_BAR	Primary Command Block Base Address	00000001h	R/W, RO
14h–17h	PCNL_BAR	Primary Control Block Base Address	00000001h	R/W, RO
18h–1Bh	SCMD_BAR	Secondary Command Block Base Address	00000001h	R/W, RO
1Ch–1Fh	SCNL_BAR	Secondary Control Block Base Address	00000001h	R/W, RO
20h–23h	BAR	Legacy Bus Master Base Address	00000001h	R/W, RO
24h–27h	ABAR / SIDPBA	AHCI Base Address / SATA Index Data Pair Base Address	00000000h	See register description
2Ch–2Dh	SVID	Subsystem Vendor Identification	0000h	R/WO
2Eh–2Fh	SID	Subsystem Identification	0000h	R/WO
34h	CAP	Capabilities Pointer	80h	RO
3Ch	INT_LN	Interrupt Line	00h	R/W
3Dh	INT_PN	Interrupt Pin	See register description.	RO
40h–41h	IDE_TIMP	Primary IDE Timing	0000h	R/W
42h–43h	IDE_TIMS	Secondary IDE Timing	0000h	R/W
44h	SIDETIM	Slave IDE Timing	00h	R/W
48h	SDMA_CNT	Synchronous DMA Control	00h	R/W



Table 121. SATA Controller PCI Register Address Map (SATA–D31:F2) (Sheet 2 of 2)

Offset	Mnemonic	Register Name	Default	Type
4Ah–4Bh	SDMA_TIM	Synchronous DMA Timing	0000h	R/W
54h–57h	IDE_CONFIG	IDE I/O Configuration	00000000h	R/W
70h–71h	PID	PCI Power Management Capability ID	See register description	RO
72h–73h	PC	PCI Power Management Capabilities	4002h	RO
74h–75h	PMCS	PCI Power Management Control and Status	0000h	R/W, RO, R/WC
80h–81h	MSICI	Message Signaled Interrupt Capability ID	7005h	RO
82h–83h	MSIMC	Message Signaled Interrupt Message Control	0000h	RO, R/W
84h–87h	MSIMA	Message Signaled Interrupt Message Address	00000000h	RO, R/W
88h–89h	MSIMD	Message Signaled Interrupt Message Data	0000h	R/W
90h	MAP	Address Map	00h	R/W
92h–93h	PCS	Port Control and Status	0000h	R/W, RO, R/WC
94h–97h	SIR	SATA Initialization Register	00000000h	R/W
A0h	SIRI	SATA Indexed Registers Index	00h	R/W
A4h	STRD	SATA Indexed Register Data	XXXXXXXXh	R/W
A8h–ABh	SCAP0	SATA Capability Register 0	00100012h	RO
ACh–AFh	SCAP1	SATA Capability Register 1	00000048h	RO
C0h	ATC	APM Trapping Control	00h	R/W
C4h	ATS	ATM Trapping Status	00h	R/WC
D0h–D3h	SP	Scratch Pad	00000000h	R/W
E0h–E3h	BFCS	BIST FIS Control/Status	00000000h	R/W, R/WC
E4h–E7h	BFTD1	BIST FIS Transmit Data, DW1	00000000h	R/W
E8h–EBh	BFTD2	BIST FIS Transmit Data, DW2	00000000h	R/W

**NOTE:** The ICH8 SATA controller is not arbitrated as a PCI device, therefore it does not need a master latency timer.

### 12.1.1 VID—Vendor Identification Register (SATA–D31:F2)

Offset Address: 00h–01h                      Attribute: RO  
 Default Value: 8086h                        Size: 16 bit  
 Lockable: No                                    Power Well: Core

Bit	Description
15:0	Vendor ID — RO. This is a 16-bit value assigned to Intel. Intel VID = 8086h



## 12.1.2 DID—Device Identification Register (SATA—D31:F2)

Offset Address:	02h–03h	Attribute:	RO
Default Value:	See bit description	Size:	16 bit
Lockable:	No	Power Well:	Core

Bit	Description
15:0	Device ID — RO. This is a 16-bit value assigned to the Intel® ICH8 SATA controller. <b>NOTE:</b> The value of this field will change dependent upon the value of the MAP Register. Refer to the <i>Intel ICH8 Family Specification Update</i> .

## 12.1.3 PCICMD—PCI Command Register (SATA—D31:F2)

Address Offset:	04h–05h	Attribute:	RO, R/W
Default Value:	0000h	Size:	16 bits

Bit	Description
15:11	Reserved
10	<b>Interrupt Disable</b> — R/W. This disables pin-based INTx# interrupts. This bit has no effect on MSI operation. 0 = Internal INTx# messages are generated if there is an interrupt and MSI is not enabled. 1 = Internal INTx# messages will not be generated.
9	Fast Back to Back Enable (FBE) — RO. Reserved as 0.
8	SERR# Enable ( <b>SERR_EN</b> ) — RO. Reserved as 0.
7	Wait Cycle Control (WCC) — RO. Reserved as 0.
6	<b>Parity Error Response (PER)</b> — R/W. 0 = Disabled. SATA controller will not generate PERR# when a data parity error is detected. 1 = Enabled. SATA controller will generate PERR# when a data parity error is detected.
5	VGA Palette Snoop (VPS) — RO. Reserved as 0.
4	Postable Memory Write Enable (PMWE) — RO. Reserved as 0.
3	Special Cycle Enable (SCE) — RO. Reserved as 0.
2	<b>Bus Master Enable (BME)</b> — R/W. This bit controls the ICH8's ability to act as a PCI master for IDE Bus Master transfers. This bit does not impact the generation of completions for split transaction commands.
1	<b>Memory Space Enable (MSE)</b> — R/W / RO. Controls access to the SATA controller's target memory space (for AHCI). <b>NOTE:</b> When MAP.MV (offset 90:bits 1:0) is not 00h, this register is Read Only (RO). Software is responsible for clearing this bit before entering combined mode.
0	<b>I/O Space Enable (IOSE)</b> — R/W. This bit controls access to the I/O space registers. 0 = Disables access to the Legacy or Native IDE ports (both Primary and Secondary) as well as the Bus Master I/O registers. 1 = Enable. Note that the Base Address register for the Bus Master registers should be programmed before this bit is set.



### 12.1.4 PCISTS — PCI Status Register (SATA–D31:F2)

Address Offset: 06h–07h                      Attribute: R/WC, RO  
 Default Value: 02B0h                      Size: 16 bits

**Note:** For the writable bits, software must write a 1 to clear bits that are set. Writing a 0 to the bit has no effect.

Bit	Description
15	<b>Detected Parity Error (DPE)</b> — R/WC. 0 = No parity error detected by SATA controller. 1 = SATA controller detects a parity error on its interface.
14	<b>Signaled System Error (SSE)</b> — RO. Reserved as 0.
13	<b>Received Master Abort (RMA)</b> — R/WC. 0 = Master abort Not generated. 1 = SATA controller, as a master, generated a master abort.
12	Reserved as 0 — RO.
11	<b>Signaled Target Abort (STA)</b> — RO. Reserved as 0.
10:9	DEVSEL# Timing Status (DEV_STS) — RO. 01 = Hardwired; Controls the device select time for the SATA controller's PCI interface.
8	<b>Data Parity Error Detected (DPED)</b> — RO. For ICH8, this bit can only be set on read completions received from SIBUS where there is a parity error. 1 = SATA controller, as a master, either detects a parity error or sees the parity error line asserted, and the parity error response bit (bit 6 of the command register) is set.
7	<b>Fast Back to Back Capable (FB2BC)</b> — RO. Reserved as 1.
6	<b>User Definable Features (UDF)</b> — RO. Reserved as 0.
5	<b>66MHz Capable (66MHZ_CAP)</b> — RO. Reserved as 1.
4	<b>Capabilities List (CAP_LIST)</b> — RO. This bit indicates the presence of a capabilities list. The minimum requirement for the capabilities list must be PCI power management for the SATA controller.
3	<b>Interrupt Status (INTS)</b> — RO. Reflects the state of INTx# messages. 0 = Interrupt is cleared (independent of the state of Interrupt Disable bit in the command register [offset 04h]). 1 = Interrupt is to be asserted
2:0	Reserved

### 12.1.5 RID—Revision Identification Register (SATA–D31:F2)

Offset Address: 08h                      Attribute: RO  
 Default Value: See bit description                      Size: 8 bits

Bit	Description
7:0	Revision ID — RO. Refer to the <i>Intel® I/O Controller Hub 8 (ICH8) Family Specification Update</i> for the value of the Revision ID Register









### 12.1.12 SCMD\_BAR—Secondary Command Block Base Address Register (IDE D31:F1)

Address Offset: 18h–1Bh                      Attribute: R/W, RO  
Default Value: 00000001h                      Size: 32 bits

Bit	Description
31:16	Reserved
15:3	<b>Base Address</b> — R/W. This field provides the base address of the I/O space (8 consecutive I/O locations).
2:1	Reserved
0	Resource Type Indicator (RTE) — RO. Hardwired to 1 to indicate a request for I/O space.

**NOTE:** This 4-byte I/O space is used in native mode for the Secondary Controller's Command Block.

### 12.1.13 SCNL\_BAR—Secondary Control Block Base Address Register (IDE D31:F1)

Address Offset: 1Ch–1Fh                      Attribute: R/W, RO  
Default Value: 00000001h                      Size: 32 bits

Bit	Description
31:16	Reserved
15:2	<b>Base Address</b> — R/W. This field provides the base address of the I/O space (4 consecutive I/O locations).
1	Reserved
0	Resource Type Indicator (RTE) — RO. Hardwired to 1 to indicate a request for I/O space.

**NOTE:** This 4-byte I/O space is used in native mode for the Secondary Controller's Command Block.





### 12.1.14 BAR — Legacy Bus Master Base Address Register (SATA–D31:F2)

Address Offset: 20h–23h                      Attribute: R/W, RO  
 Default Value: 00000001h                  Size: 32 bits

The Bus Master IDE interface function uses Base Address register 5 to request a 16-byte IO space to provide a software interface to the Bus Master functions. Only 12 bytes are actually used (6 bytes for primary, 6 bytes for secondary). Only bits [15:4] are used to decode the address.

Bit	Description
31:16	Reserved
15:4	<b>Base Address</b> — R/W. This field provides the base address of the I/O space (16 consecutive I/O locations).
3:1	Reserved
0	Resource Type Indicator (RTE) — RO. Hardwired to 1 to indicate a request for I/O space.

### 12.1.15 ABAR/SIDPBA1 — AHCI Base Address Register/Serial ATA Index Data Pair Base Address (SATA–D31:F2)

When the programming interface is not IDE (i.e., is not 01h), this register is named ABAR. When the programming interface is IDE, this register becomes SIDPBA.

Note that hardware does not clear those BA bits when switching from IDE SKU to non-IDE SKU or vice versa. BIOS is responsible for clearing those bits to 0 since the number of writable bits changes after SKU switching (as indicated by a change in CC.SCC). In the case, this register will then have to be re-programmed to a proper value.

#### 12.1.15.1 When CC.SCC is not 01h

Address Offset: 24–27h                      Attribute: R/WO  
 Default Value: 00000000h                  Size: 32 bits

When the programming interface is not IDE, the register represents a memory BAR allocating space for the AHCI memory registers defined in [Section 12.4](#).

Bit	Description
31:11	<b>Base Address (BA)</b> — R/W. Base address of register memory space (aligned to 1 KB)
10:4	Reserved
3	Prefetchable (PF) — RO. Indicates that this range is not pre-fetchable
2:1	Type (TP) — RO. Indicates that this range can be mapped anywhere in 32-bit address space.
0	Resource Type Indicator (RTE) — RO. Hardwired to 0 to indicate a request for register memory space.

#### NOTES:

- When the MAP.MV register is programmed for combined mode (00b), this register is RO. Software is responsible for clearing this bit before entering combined mode.
- The ABAR register must be set to a value of 0001\_0000h or greater.



### 12.1.15.2 When CC.SCC is 01h

Address Offset: 24h–27h                      Attribute: R/WO  
 Default Value: 00000001h                  Size: 32 bits

When the programming interface is IDE, the register becomes an I/O BAR allocating 16 bytes of I/O space for the I/O-mapped registers defined in Section 12.3. Note that although 16 bytes of locations are allocated, only 8 bytes are used to as SINDX and SDATA registers; with the remaining 8 bytes preserved for future enhancement.

Bit	Description
31:16	Reserved
15:4	<b>Base Address (BA)</b> — R/W. Base address of the I/O space.
3:1	Reserved
0	Resource Type Indicator (RTE) — RO. Indicates a request for I/O space.

### 12.1.16 SVID—Subsystem Vendor Identification Register (SATA–D31:F2)

Address Offset: 2Ch–2Dh                      Attribute: R/WO  
 Default Value: 0000h                        Size: 16 bits  
 Lockable: No                                  Power Well: Core

Bit	Description
15:0	<b>Subsystem Vendor ID (SVID)</b> — R/WO. Value is written by BIOS. No hardware action taken on this value.

### 12.1.17 SID—Subsystem Identification Register (SATA–D31:F2)

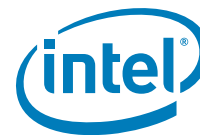
Address Offset: 2Eh–2Fh                      Attribute: R/WO  
 Default Value: 0000h                        Size: 16 bits  
 Lockable: No                                  Power Well: Core

Bit	Description
15:0	<b>Subsystem ID (SID)</b> — R/WO. Value is written by BIOS. No hardware action taken on this value.

### 12.1.18 CAP—Capabilities Pointer Register (SATA–D31:F2)

Address Offset: 34h                              Attribute: RO  
 Default Value: 80h                              Size: 8 bits

Bit	Description
7:0	Capabilities Pointer (CAP_PTR) — RO. Indicates that the first capability pointer offset is 80h. This value changes to 70h if the MAP.MV register (Dev 31:F2:90h, bits 1:0) in configuration space indicates that the SATA function and PATA functions are combined (values of 10b or 10b) or Sub Class Code (CC.SCC) (Dev 31:F2:0Ah) is configure as IDE mode (value of 01).



### 12.1.19 INT\_LN—Interrupt Line Register (SATA–D31:F2)

Address Offset: 3Ch Attribute: R/W  
Default Value: 00h Size: 8 bits

Bit	Description
7:0	<b>Interrupt Line</b> — R/W. This field is used to communicate to software the interrupt line that the interrupt pin is connected to.

### 12.1.20 INT\_PN—Interrupt Pin Register (SATA–D31:F2)

Address Offset: 3Dh Attribute: RO  
Default Value: See Register Description Size: 8 bits

Bit	Description
7:0	<b>Interrupt Pin</b> — RO. This reflects the value of D31IP.SIP (Chipset Configuration Registers: Offset 3100h:bits 11:8).

### 12.1.21 IDE\_TIM — IDE Timing Register (SATA–D31:F2)

Address Offset: Primary: 40h–41h Attribute: R/W  
Secondary: 42h–43h  
Default Value: 0000h Size: 16 bits

This register controls the timings driven on the IDE cable for PIO and 8237 style DMA transfers. It also controls operation of the buffer for PIO transfers.

**Note:** This register is R/W to maintain software compatibility and enable parallel ATA functionality when the PCI functions are combined. These bits have no effect on SATA operation unless otherwise noted.

Bit	Description
15	<b>IDE Decode Enable (IDE)</b> — R/W. Individually enable/disable the Primary or Secondary decode. 0 = Disable. 1 = Enables the Intel® ICH8 to decode the associated Command Blocks (1F0–1F7h for primary, 170–177h for secondary) and Control Block (3F6h for primary and 376h for secondary). This bit effects the IDE decode ranges for both legacy and native-Mode decoding. <b>NOTE:</b> This bit affects SATA operation in both combined and non-combined ATA modes. See <a href="#">Section 5.16</a> for more on ATA modes of operation.
14	<b>Drive 1 Timing Register Enable (SITRE)</b> — R/W. 0 = Use bits 13:12, 9:8 for both drive 0 and drive 1. 1 = Use bits 13:12, 9:8 for drive 0, and use the Slave IDE Timing register for drive 1
13:12	<b>IORDY Sample Point (ISP)</b> — R/W. The setting of these bits determines the number of PCI clocks between IDE IOR#/IOW# assertion and the first IORDY sample point. 00 = 5 clocks 01 = 4 clocks 10 = 3 clocks 11 = Reserved



Bit	Description
11:10	Reserved
9:8	<p><b>Recovery Time (RCT)</b> — R/W. The setting of these bits determines the minimum number of PCI clocks between the last IORDY sample point and the IOR#/IOW# strobe of the next cycle.</p> <p>00 = 4 clocks            01 = 3 clocks            10 = 2 clocks            11 = 1 clock</p>
7	<p><b>Drive 1 DMA Timing Enable (DTE1)</b> — R/W.</p> <p>0 = Disable.            1 = Enable the fast timing mode for DMA transfers only for this drive. PIO transfers to the IDE data port will run in compatible timing.</p>
6	<p><b>Drive 1 Prefetch/Posting Enable (PPE1)</b> — R/W.</p> <p>0 = Disable.            1 = Enable Prefetch and posting to the IDE data port for this drive.</p>
5	<p><b>Drive 1 IORDY Sample Point Enable (IE1)</b> — R/W.</p> <p>0 = Disable IORDY sampling for this drive.            1 = Enable IORDY sampling for this drive.</p>
4	<p><b>Drive 1 Fast Timing Bank (TIME1)</b> — R/W.</p> <p>0 = Accesses to the data port will use compatible timings for this drive.            1 = When this bit = 1 and bit 14 = 0, accesses to the data port will use bits 13:12 for the IORDY sample point, and bits 9:8 for the recovery time. When this bit = 1 and bit 14 = 1, accesses to the data port will use the IORDY sample point and recover time specified in the slave IDE timing register.</p>
3	<p><b>Drive 0 DMA Timing Enable (DTE0)</b> — R/W.</p> <p>0 = Disable            1 = Enable fast timing mode for DMA transfers only for this drive. PIO transfers to the IDE data port will run in compatible timing.</p>
2	<p><b>Drive 0 Prefetch/Posting Enable (PPE0)</b> — R/W.</p> <p>0 = Disable prefetch and posting to the IDE data port for this drive.            1 = Enable prefetch and posting to the IDE data port for this drive.</p>
1	<p><b>Drive 0 IORDY Sample Point Enable (IE0)</b> — R/W.</p> <p>0 = Disable IORDY sampling is disabled for this drive.            1 = Enable IORDY sampling for this drive.</p>
0	<p><b>Drive 0 Fast Timing Bank (TIME0)</b> — R/W.</p> <p>0 = Accesses to the data port will use compatible timings for this drive.            1 = Accesses to the data port will use bits 13:12 for the IORDY sample point, and bits 9:8 for the recovery time</p>





### 12.1.23 SDMA\_CNT—Synchronous DMA Control Register (SATA–D31:F2)

Address Offset: 48h                                  Attribute: R/W  
 Default Value: 00h                                 Size: 8 bits

**Note:** This register is R/W to maintain software compatibility and enable parallel ATA functionality when the PCI functions are combined. These bits have no effect on SATA operation unless otherwise noted.

Bit	Description
7:4	Reserved
3	<b>Secondary Drive 1 Synchronous DMA Mode Enable (SSDE1)</b> — R/W. 0 = Disable (default) 1 = Enable Synchronous DMA mode for secondary channel drive 1
2	<b>Secondary Drive 0 Synchronous DMA Mode Enable (SSDE0)</b> — R/W. 0 = Disable (default) 1 = Enable Synchronous DMA mode for secondary drive 0.
1	<b>Primary Drive 1 Synchronous DMA Mode Enable (PSDE1)</b> — R/W. 0 = Disable (default) 1 = Enable Synchronous DMA mode for primary channel drive 1
0	<b>Primary Drive 0 Synchronous DMA Mode Enable (PSDE0)</b> — R/W. 0 = Disable (default) 1 = Enable Synchronous DMA mode for primary channel drive 0

### 12.1.24 SDMA\_TIM—Synchronous DMA Timing Register (SATA–D31:F2)

Address Offset: 4Ah–4Bh                              Attribute: R/W  
 Default Value: 0000h                                 Size: 16 bits

**Note:** This register is R/W to maintain software compatibility and enable parallel ATA functionality when the PCI functions are combined. These bits have no effect on SATA operation, unless otherwise noted.

Bit	Description															
15:14	Reserved															
13:12	<b>Secondary Drive 1 Cycle Time (SCT1)</b> — R/W. For Ultra ATA mode. The setting of these bits determines the minimum write strobe cycle time (CT). The DMARDY#-to-STOP (RP) time is also determined by the setting of these bits.  <table style="width:100%; border:none;"> <tr> <td style="text-align:center;"><b>SCB1 = 0</b> (33 MHz clock)</td> <td style="text-align:center;"><b>SCB1 = 1</b> (66 MHz clock)</td> <td style="text-align:center;"><b>FAST_SCB1 = 1</b> (133 MHz clock)</td> </tr> <tr> <td>00 = CT 4 clocks, RP 6 clocks</td> <td>00 = Reserved</td> <td>00 = Reserved</td> </tr> <tr> <td>01 = CT 3 clocks, RP 5 clocks</td> <td>01 = CT 3 clocks, RP 8 clocks</td> <td>01 = CT 3 clocks, RP 16 clocks</td> </tr> <tr> <td>10 = CT 2 clocks, RP 4 clocks</td> <td>10 = CT 2 clocks, RP 8 clocks</td> <td>10 = Reserved</td> </tr> <tr> <td>11 = Reserved</td> <td>11 = Reserved</td> <td>11 = Reserved</td> </tr> </table>	<b>SCB1 = 0</b> (33 MHz clock)	<b>SCB1 = 1</b> (66 MHz clock)	<b>FAST_SCB1 = 1</b> (133 MHz clock)	00 = CT 4 clocks, RP 6 clocks	00 = Reserved	00 = Reserved	01 = CT 3 clocks, RP 5 clocks	01 = CT 3 clocks, RP 8 clocks	01 = CT 3 clocks, RP 16 clocks	10 = CT 2 clocks, RP 4 clocks	10 = CT 2 clocks, RP 8 clocks	10 = Reserved	11 = Reserved	11 = Reserved	11 = Reserved
<b>SCB1 = 0</b> (33 MHz clock)	<b>SCB1 = 1</b> (66 MHz clock)	<b>FAST_SCB1 = 1</b> (133 MHz clock)														
00 = CT 4 clocks, RP 6 clocks	00 = Reserved	00 = Reserved														
01 = CT 3 clocks, RP 5 clocks	01 = CT 3 clocks, RP 8 clocks	01 = CT 3 clocks, RP 16 clocks														
10 = CT 2 clocks, RP 4 clocks	10 = CT 2 clocks, RP 8 clocks	10 = Reserved														
11 = Reserved	11 = Reserved	11 = Reserved														
11:10	Reserved															



Bit	Description															
9:8	<p><b>Secondary Drive 0 Cycle Time (SCT0)</b> — R/W. For Ultra ATA mode. The setting of these bits determines the minimum write strobe cycle time (CT). The DMARDY#-to-STOP (RP) time is also determined by the setting of these bits.</p> <table border="0"> <tr> <td style="text-align: center;"><b>SCB1 = 0 (33 MHz clock)</b></td> <td style="text-align: center;"><b>SCB1 = 1 (66 MHz clock)</b></td> <td style="text-align: center;"><b>FAST_SCB1 = 1 (133 MHz clock)</b></td> </tr> <tr> <td>00 = CT 4 clocks, RP 6 clocks</td> <td>00 = Reserved</td> <td>00 = Reserved</td> </tr> <tr> <td>01 = CT 3 clocks, RP 5 clocks</td> <td>01 = CT 3 clocks, RP 8 clocks</td> <td>01 = CT 3 clocks, RP 16 clocks</td> </tr> <tr> <td>10 = CT 2 clocks, RP 4 clocks</td> <td>10 = CT 2 clocks, RP 8 clocks</td> <td>10 = Reserved</td> </tr> <tr> <td>11 = Reserved</td> <td>11 = Reserved</td> <td>11 = Reserved</td> </tr> </table>	<b>SCB1 = 0 (33 MHz clock)</b>	<b>SCB1 = 1 (66 MHz clock)</b>	<b>FAST_SCB1 = 1 (133 MHz clock)</b>	00 = CT 4 clocks, RP 6 clocks	00 = Reserved	00 = Reserved	01 = CT 3 clocks, RP 5 clocks	01 = CT 3 clocks, RP 8 clocks	01 = CT 3 clocks, RP 16 clocks	10 = CT 2 clocks, RP 4 clocks	10 = CT 2 clocks, RP 8 clocks	10 = Reserved	11 = Reserved	11 = Reserved	11 = Reserved
<b>SCB1 = 0 (33 MHz clock)</b>	<b>SCB1 = 1 (66 MHz clock)</b>	<b>FAST_SCB1 = 1 (133 MHz clock)</b>														
00 = CT 4 clocks, RP 6 clocks	00 = Reserved	00 = Reserved														
01 = CT 3 clocks, RP 5 clocks	01 = CT 3 clocks, RP 8 clocks	01 = CT 3 clocks, RP 16 clocks														
10 = CT 2 clocks, RP 4 clocks	10 = CT 2 clocks, RP 8 clocks	10 = Reserved														
11 = Reserved	11 = Reserved	11 = Reserved														
7:6	Reserved															
5:4	<p><b>Primary Drive 1 Cycle Time (PCT1)</b> — R/W. For Ultra ATA mode, the setting of these bits determines the minimum write strobe cycle time (CT). The DMARDY#-to-STOP (RP) time is also determined by the setting of these bits.</p> <table border="0"> <tr> <td style="text-align: center;"><b>PCB1 = 0 (33 MHz clock)</b></td> <td style="text-align: center;"><b>PCB1 = 1 (66 MHz clock)</b></td> <td style="text-align: center;"><b>FAST_PCB1 = 1 (133 MHz clock)</b></td> </tr> <tr> <td>00 = CT 4 clocks, RP 6 clocks</td> <td>00 = Reserved</td> <td>00 = Reserved</td> </tr> <tr> <td>01 = CT 3 clocks, RP 5 clocks</td> <td>01 = CT 3 clocks, RP 8 clocks</td> <td>01 = CT 3 clocks, RP 16 clocks</td> </tr> <tr> <td>10 = CT 2 clocks, RP 4 clocks</td> <td>10 = CT 2 clocks, RP 8 clocks</td> <td>10 = Reserved</td> </tr> <tr> <td>11 = Reserved</td> <td>11 = Reserved</td> <td>11 = Reserved</td> </tr> </table>	<b>PCB1 = 0 (33 MHz clock)</b>	<b>PCB1 = 1 (66 MHz clock)</b>	<b>FAST_PCB1 = 1 (133 MHz clock)</b>	00 = CT 4 clocks, RP 6 clocks	00 = Reserved	00 = Reserved	01 = CT 3 clocks, RP 5 clocks	01 = CT 3 clocks, RP 8 clocks	01 = CT 3 clocks, RP 16 clocks	10 = CT 2 clocks, RP 4 clocks	10 = CT 2 clocks, RP 8 clocks	10 = Reserved	11 = Reserved	11 = Reserved	11 = Reserved
<b>PCB1 = 0 (33 MHz clock)</b>	<b>PCB1 = 1 (66 MHz clock)</b>	<b>FAST_PCB1 = 1 (133 MHz clock)</b>														
00 = CT 4 clocks, RP 6 clocks	00 = Reserved	00 = Reserved														
01 = CT 3 clocks, RP 5 clocks	01 = CT 3 clocks, RP 8 clocks	01 = CT 3 clocks, RP 16 clocks														
10 = CT 2 clocks, RP 4 clocks	10 = CT 2 clocks, RP 8 clocks	10 = Reserved														
11 = Reserved	11 = Reserved	11 = Reserved														
3:2	Reserved															
1:0	<p><b>Primary Drive 0 Cycle Time (PCT0)</b> — R/W. For Ultra ATA mode, the setting of these bits determines the minimum write strobe cycle time (CT). The DMARDY#-to-STOP (RP) time is also determined by the setting of these bits.</p> <table border="0"> <tr> <td style="text-align: center;"><b>PCB1 = 0 (33 MHz clock)</b></td> <td style="text-align: center;"><b>PCB1 = 1 (66 MHz clock)</b></td> <td style="text-align: center;"><b>FAST_PCB1 = 1 (133 MHz clock)</b></td> </tr> <tr> <td>00 = CT 4 clocks, RP 6 clocks</td> <td>00 = Reserved</td> <td>00 = Reserved</td> </tr> <tr> <td>01 = CT 3 clocks, RP 5 clocks</td> <td>01 = CT 3 clocks, RP 8 clocks</td> <td>01 = CT 3 clocks, RP 16 clocks</td> </tr> <tr> <td>10 = CT 2 clocks, RP 4 clocks</td> <td>10 = CT 2 clocks, RP 8 clocks</td> <td>10 = Reserved</td> </tr> <tr> <td>11 = Reserved</td> <td>11 = Reserved</td> <td>11 = Reserved</td> </tr> </table>	<b>PCB1 = 0 (33 MHz clock)</b>	<b>PCB1 = 1 (66 MHz clock)</b>	<b>FAST_PCB1 = 1 (133 MHz clock)</b>	00 = CT 4 clocks, RP 6 clocks	00 = Reserved	00 = Reserved	01 = CT 3 clocks, RP 5 clocks	01 = CT 3 clocks, RP 8 clocks	01 = CT 3 clocks, RP 16 clocks	10 = CT 2 clocks, RP 4 clocks	10 = CT 2 clocks, RP 8 clocks	10 = Reserved	11 = Reserved	11 = Reserved	11 = Reserved
<b>PCB1 = 0 (33 MHz clock)</b>	<b>PCB1 = 1 (66 MHz clock)</b>	<b>FAST_PCB1 = 1 (133 MHz clock)</b>														
00 = CT 4 clocks, RP 6 clocks	00 = Reserved	00 = Reserved														
01 = CT 3 clocks, RP 5 clocks	01 = CT 3 clocks, RP 8 clocks	01 = CT 3 clocks, RP 16 clocks														
10 = CT 2 clocks, RP 4 clocks	10 = CT 2 clocks, RP 8 clocks	10 = Reserved														
11 = Reserved	11 = Reserved	11 = Reserved														



## 12.1.25 IDE\_CONFIG—IDE I/O Configuration Register (SATA-D31:F2)

Address Offset: 54h–57h Attribute: R/W  
 Default Value: 00000000h Size: 32 bits

**Note:** This register is R/W to maintain software compatibility and enable parallel ATA functionality when the PCI functions are combined. These bits have no effect on SATA operation, unless otherwise noted.

Bit	Description
31:24	Reserved
23:20	Scratchpad (SP2). Intel® ICH8 does not perform any actions on these bits.
19:18	<p><b>SEC_SIG_MODE</b> — R/W. These bits are used to control mode of the Secondary IDE signal pins for swap bay support.</p> <p>If the SRS bit (Chipset Configuration Registers: Offset 3414h: bit 1) is 1, the reset states of bits 19:18 will be 01 (tri-state) instead of 00 (normal).</p> <p>00 = Normal (Enabled)            01 = Tri-state (Disabled)            10 = Drive low (Disabled)            11 = Reserved</p> <p><b>NOTE:</b> In the non-combined mode, these bits are for software compatibility and have no effect on the SATA controller. In the combined mode, these bits are controlling the behavior of the PATA controller. (Mobile Only)</p>
17:16	<p><b>PRIM_SIG_MODE</b> — R/W. These bits are used to control mode of the Primary IDE signal pins for mobile swap bay support.</p> <p>If the PRS bit (Chipset Confide Registers: Offset 3414h: bit 1) is 1, the reset states of bits 17:16 will be 01 (tri-state) instead of 00 (normal).</p> <p>00 = Normal (Enabled)            01 = Tri-state (Disabled)            10 = Drive low (Disabled)            11 = Reserved</p> <p><b>NOTE:</b> In the non-combined mode, these bits are for software compatibility and have no effect on the SATA controller. In the combined mode, these bits are controlling the behavior of the PATA controller. (Mobile Only)</p>
15	<p><b>Fast Secondary Drive 1 Base Clock (FAST_SCB1)</b> — R/W. This bit is used in conjunction with the SCT1 bits (D31:F2:4Ah, bits 13:12) to enable/disable Ultra ATA/100 timings for the Secondary Slave drive.</p> <p>0 = Disable Ultra ATA/100 timing for the Secondary Slave drive.            1 = Enable Ultra ATA/100 timing for the Secondary Slave drive (overrides bit 3 in this register).</p>
14	<p><b>Fast Secondary Drive 0 Base Clock (FAST_SCB0)</b> — R/W. This bit is used in conjunction with the SCT0 bits (D31:F2:4Ah, bits 9:8) to enable/disable Ultra ATA/100 timings for the Secondary Master drive.</p> <p>0 = Disable Ultra ATA/100 timing for the Secondary Master drive.            1 = Enable Ultra ATA/100 timing for the Secondary Master drive (overrides bit 2 in this register).</p>



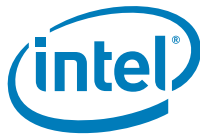


Bit	Description
13	<b>Fast Primary Drive 1 Base Clock (FAST_PCB1)</b> — R/W. This bit is used in conjunction with the PCT1 bits (D31:F2:4Ah, bits 5:4) to enable/disable Ultra ATA/100 timings for the Primary Slave drive. 0 = Disable Ultra ATA/100 timing for the Primary Slave drive. 1 = Enable Ultra ATA/100 timing for the Primary Slave drive (overrides bit 1 in this register).
12	<b>Fast Primary Drive 0 Base Clock (FAST_PCB0)</b> — R/W. This bit is used in conjunction with the PCT0 bits (D31:F2:4Ah, bits 1:0) to enable/disable Ultra ATA/100 timings for the Primary Master drive. 0 = Disable Ultra ATA/100 timing for the Primary Master drive. 1 = Enable Ultra ATA/100 timing for the Primary Master drive (overrides bit 0 in this register).
11:8	Reserved
7:4	Scratchpad (SP1). ICH8 does not perform any action on these bits.
3	<b>Secondary Drive 1 Base Clock (SCB1)</b> — R/W. 0 = 33 MHz base clock for Ultra ATA timings. 1 = 66 MHz base clock for Ultra ATA timings
2	<b>Secondary Drive 0 Base Clock (SCB0)</b> — R/W. 0 = 33 MHz base clock for Ultra ATA timings. 1 = 66 MHz base clock for Ultra ATA timings
1	<b>Primary Drive 1 Base Clock (PCB1)</b> — R/W. 0 = 33 MHz base clock for Ultra ATA timings. 1 = 66 MHz base clock for Ultra ATA timings
0	<b>Primary Drive 0 Base Clock (PCB0)</b> — R/W. 0 = 33 MHz base clock for Ultra ATA timings. 1 = 66 MHz base clock for Ultra ATA timings

### 12.1.26 PID—PCI Power Management Capability Identification Register (SATA—D31:F2)

Address Offset: 70h–71h                      Attribute: RO  
 Default Value: XX01h                      Size: 16 bits

Bits	Description
15:8	Next Capability (NEXT) — RO. 00h — if SCC = 01h (IDE mode). A8h — for all other values of SCC to point to the next capability structure.
7:0	Capability ID (CID) — RO. Indicates that this pointer is a PCI power management.



### 12.1.27 PC—PCI Power Management Capabilities Register (SATA—D31:F2)

Address Offset: 72h–73h Attribute: RO  
 Default Value: 4003h Size: 16 bits

Bits	Description
15:11	PME Support (PME_SUP) — RO. Indicates PME# can be generated from the D3 <sub>HOT</sub> state in the SATA host controller.
10	D2 Support (D2_SUP) — RO. Hardwired to 0. The D2 state is not supported
9	D1 Support (D1_SUP) — RO. Hardwired to 0. The D1 state is not supported
8:6	Auxiliary Current (AUX_CUR) — RO. PME# from D3 <sub>COLD</sub> state is not supported, therefore this field is 000b.
5	Device Specific Initialization (DSI) — RO. Hardwired to 0 to indicate that no device-specific initialization is required.
4	Reserved
3	PME Clock (PME_CLK) — RO. Hardwired to 0 to indicate that PCI clock is not required to generate PME#.
2:0	Version (VER) — RO. Hardwired to 011 to indicates support for Revision 1.2 of the PCI Power Management Specification.

### 12.1.28 PMCS—PCI Power Management Control and Status Register (SATA—D31:F2)

Address Offset: 74h–75h Attribute: RO, R/W, R/WC  
 Default Value: 0008h Size: 16 bits

Bits	Description
15	<b>PME Status (PMES)</b> — R/WC. Bit is set when a PME event is to be requested, and if this bit and PMEE is set, a PME# will be generated from the SATA controller
14:9	Reserved
8	<b>PME Enable (PMEE)</b> — R/W. When set, the SATA controller generates PME# form D3 <sub>HOT</sub> on a wake event.
7:4	Reserved
3	<b>No Soft Reset (NSFRST)</b> — RO. These bits are used to indicate whether devices transitioning from D3 <sub>HOT</sub> state to D0 state will perform an internal reset. 0 = Device transitioning from D3 <sub>HOT</sub> state to D0 state perform an internal reset. 1 = Device transitioning from D3 <sub>HOT</sub> state to D0 state do not perform an internal reset. Configuration content is preserved. Upon transition from the D3 <sub>HOT</sub> state to D0 state initialized state, no additional operating system intervention is required to preserve configuration context beyond writing to the Power State bits. Regardless of this bit, the controller transition from D3 <sub>HOT</sub> state to D0 state by a system or bus segment reset will return to the state D0 uninitialized with only PME context preserved if PME is supported and enabled.
2	Reserved
1:0	<b>Power State (PS)</b> — R/W. These bits are used both to determine the current power state of the SATA controller and to set a new power state. 00 = D0 state 11 = D3 <sub>HOT</sub> state When in the D3 <sub>HOT</sub> state, the controller's configuration space is available, but the I/O and memory spaces are not. Additionally, interrupts are blocked.



### 12.1.29 MSICI—Message Signaled Interrupt Capability Identification (SATA–D31:F2)

Address Offset: 80h–81h                                  Attribute:                  RO  
Default Value: 7005h    Size:                         16 bits

**Note:** There is no support for MSI when the software is operating in legacy (IDE) mode when AHCI is not enabled. Prior to switching from AHCI to IDE mode, software **must** make sure that MSI is disabled.

Bits	Description
15:8	<b>Next Pointer (NEXT)</b> : Indicates the next item in the list is the PCI power management pointer.
7:0	<b>Capability ID (CID)</b> : Capabilities ID indicates MSI.

### 12.1.30 MSIMC—Message Signaled Interrupt Message Control (SATA–D31:F2)

Address Offset: 82h–83h                                  Attribute:                  R/W, RO  
Default Value: 0000h    Size:                         16 bits

**Note:** There is no support for MSI when the software is operating in legacy (IDE) mode when AHCI is not enabled. Prior to switching from AHCI to IDE mode, software **must** make sure that MSI is disabled.

Bits	Description
15:8	Reserved
7	<b>64 Bit Address Capable (C64)</b> : Capable of generating a 32-bit message only.



Bits	Description																													
6:4	<p><b>Multiple Message Enable (MME):</b> When this field is cleared to '000' (and MSIE is set), only a single MSI message will be generated for all SATA ports, and bits [15:0] of the message vector will be driven from MD[15:0].</p> <p>When this field is set to '001' (and MSIE is set), two MSI messages will be generated. Bit [15:1] of the message vectors will be driven from MD[15:1] and bit [0] of the message vector will be driven dependent on which SATA port is the source of the interrupt: '0' for port 0, and '1' for ports 1, 2, 3, 4 and 5.</p> <p>When this field is set to '010' (and MSIE is set), four messages will be generated, one for each SATA port. Bits[15:2] of the message vectors will be driven from MD[15:2], while bits[1:0] will be driven dependent on which SATA port is the source of the interrupt: '00' for port 0, '01' for port 1, '10' for port 2, and '11' for ports 3, 4, and 5).</p> <p>When this field is set to '100' (and MSIE is set), seven messages will be generated, one for each SATA port. Bits[15:2] of the message vectors will be driven from MD[15:3], while bits[2:0] will be driven dependent on which SATA port is the source of the interrupt: '000' for port 0, '001' for port 1, '010' for port 2, '011' for port 3, '100' for port 4, '101 for port 5, and '110' for port 6 (CCC interrupt).</p> <table border="1" data-bbox="501 810 1297 1276"> <thead> <tr> <th rowspan="2">MME</th> <th colspan="4">Value Driven on MSI Memory Write</th> </tr> <tr> <th>Bits[15:2]</th> <th>Bit[2]</th> <th>Bit[1]</th> <th>Bit[0]</th> </tr> </thead> <tbody> <tr> <td>000</td> <td>MD[15:0]</td> <td>MD[1]</td> <td>MD[1]</td> <td>MD[0]</td> </tr> <tr> <td>001</td> <td>MD[15:2]</td> <td>MD[1]</td> <td>MD[1]</td> <td>Ports 0: 0 Ports 1,2,3: 1</td> </tr> <tr> <td>010</td> <td>MD[15:2]</td> <td>Port 0: 0 Port 1: 0 Port 2: 1 Port 3: 1</td> <td>Port 0: 0 Port 1: 0 Port 2: 1 Port 3: 1</td> <td>Port 0: 0 Port 1: 1 Port 2: 0 Port 3: 1</td> </tr> <tr> <td>100</td> <td>MD[15:3]</td> <td>Port 0: 000 Port 1: 001 Port 2: 010 Port 3: 011 Port 4: 100 Port 5: 101</td> <td>Port 0: 000 Port 1: 001 Port 2: 010 Port 3: 011 Port 4: 100 Port 5: 101</td> <td>Port 0: 000 Port 1: 001 Port 2: 010 Port 3: 011 Port 4: 100 Port 5: 101</td> </tr> </tbody> </table> <p>Values '011b' to '111b' are reserved. If this field is set to one of these reserved values, the results are undefined.</p> <p><b>NOTE:</b> Note: The CCC interrupt is generated on unimplemented port (AHCI PI register bit equal to 0). If CCC interrupt is disabled, no MSI shall be generated for the port dedicated to the CCC interrupt. When CCC interrupt occurs, MD[2:0] is dependant on CCC_CTL.INT (in addition to MME).</p>	MME	Value Driven on MSI Memory Write				Bits[15:2]	Bit[2]	Bit[1]	Bit[0]	000	MD[15:0]	MD[1]	MD[1]	MD[0]	001	MD[15:2]	MD[1]	MD[1]	Ports 0: 0 Ports 1,2,3: 1	010	MD[15:2]	Port 0: 0 Port 1: 0 Port 2: 1 Port 3: 1	Port 0: 0 Port 1: 0 Port 2: 1 Port 3: 1	Port 0: 0 Port 1: 1 Port 2: 0 Port 3: 1	100	MD[15:3]	Port 0: 000 Port 1: 001 Port 2: 010 Port 3: 011 Port 4: 100 Port 5: 101	Port 0: 000 Port 1: 001 Port 2: 010 Port 3: 011 Port 4: 100 Port 5: 101	Port 0: 000 Port 1: 001 Port 2: 010 Port 3: 011 Port 4: 100 Port 5: 101
MME	Value Driven on MSI Memory Write																													
	Bits[15:2]	Bit[2]	Bit[1]	Bit[0]																										
000	MD[15:0]	MD[1]	MD[1]	MD[0]																										
001	MD[15:2]	MD[1]	MD[1]	Ports 0: 0 Ports 1,2,3: 1																										
010	MD[15:2]	Port 0: 0 Port 1: 0 Port 2: 1 Port 3: 1	Port 0: 0 Port 1: 0 Port 2: 1 Port 3: 1	Port 0: 0 Port 1: 1 Port 2: 0 Port 3: 1																										
100	MD[15:3]	Port 0: 000 Port 1: 001 Port 2: 010 Port 3: 011 Port 4: 100 Port 5: 101	Port 0: 000 Port 1: 001 Port 2: 010 Port 3: 011 Port 4: 100 Port 5: 101	Port 0: 000 Port 1: 001 Port 2: 010 Port 3: 011 Port 4: 100 Port 5: 101																										
3:1	<p><b>Multiple Message Capable (MMC):</b> Indicates the number of interrupt messages supported by the ICH8 SATA controller.</p> <p>000 = 1 MSI Capable (When CC.SCC bit is set to 01h. MSI is not supported in IDE mode)</p> <p>010 = 4 MSI Capable</p> <p>100 = 8 MSI Capable</p>																													
0	<p><b>MSI Enable (MSIE):</b> If set, MSI is enabled and traditional interrupt pins are not used to generate interrupts. This bit is R/W when SC.SCC is not 01h and is read-only 0 when CC.SCC is 01h. Note that CMD.ID bit has no effect on MSI.</p> <p><b>NOTE:</b> Software must clear this bit to '0' to disable MSI first before changing the number of messages allocated in the MMC field. Software must also make sure this bit is cleared to '0' when operating in legacy mode (when GHC.AE = 0).</p>																													



### 12.1.31 MSIMA— Message Signaled Interrupt Message Address (SATA–D31:F2)

Address Offset: 84h–87h    Attribute:                RO, R/W  
 Default Value: 00000000h                                      Size:                      32 bits

**Note:** There is no support for MSI when the software is operating in legacy (IDE) mode when AHCI is not enabled. Prior to switching from AHCI to IDE mode, software **must** make sure that MSI is disabled.

Bits	Description
31:2	<b>Address (ADDR):</b> Lower 32 bits of the system specified message address, always DWORD aligned.
1:0	Reserved

### 12.1.32 MSIMD—Message Signaled Interrupt Message Data (SATA–D31:F2)

Address Offset: 88h–89h    Attribute:                R/W  
 Default Value: 0000h    Size:                      16 bits

**Note:** There is no support for MSI when the software is operating in legacy (IDE) mode when AHCI is not enabled. Prior to switching from AHCI to IDE mode, software **must** make sure that MSI is disabled.

Bits	Description
15:0	<b>Data (DATA)— R/W:</b> This 16-bit field is programmed by system software if MSI is enabled. Its content is driven onto the lower word of the data bus of the MSI memory write transaction. Note that when the MME field is set to '001' or '010', bit [0] and bits [1:0] respectively of the MSI memory write transaction will be driven based on the source of the interrupt rather than from MD[2:0]. See the description of the MME field.

### 12.1.33 MAP—Address Map Register (SATA—D31:F2)

Address Offset: 90h Attribute: R/W  
Default Value: 00h Size: 8 bits

Bits	Description
7:6	<p><b>SATA Mode Select (SMS)</b> — R/W: SW programs these bits to control the mode in which the SATA HBA should operate:</p> <p>00b = IDE mode  01b = AHCI mode  10b = RAID mode  11b = Reserved</p> <p><b>NOTES:</b></p> <ol style="list-style-type: none"> <li>1. The SATA Function Device ID will change based on the value of this register.</li> <li>2. When combined mode is used (MV = '10'), only IDE mode is allowed. IDE mode can be selected when AHCI and/or RAID are enabled</li> <li>3. When switching from AHCI or RAID mode to IDE mode, a 2 port SATA controller (Device 31, Function 5) shall be enabled.</li> <li>4. AHCI mode may only be selected when MV = 00</li> <li>5. RAID mode may only be selected when MV = 00</li> <li>6. Programming these bits with values that are invalid (e.g. selecting RAID when in combined mode) will result in indeterministic behavior by the hardware.</li> <li>7. Software shall not manipulate SMS during runtime operation (i.e., the OS will not do this). The BIOS may choose to switch from one mode to another during POST.</li> </ol>
5:2	Reserved.
1:0 (Desktop Only)	<b>Map Value</b> — R/W. Map Value (MV): Reserved
1:0 (Mobile Only)	<p><b>Map Value</b> — R/W. Map Value (MV): The value in the bits below indicate the address range the SATA ports responds to, and whether or not the PATA and SATA functions are combined. When in combined mode, the AHCI memory space is not available and AHCI may not be used.</p> <p>00 =Non-combined. P0 is primary master, P2 is the primary slave. P1 is secondary master, P3 is the secondary slave.</p> <p>01 =Reserved  10 =Combined. P0 is primary master. P2 is primary slave. IDE is secondary  11 =Reserved</p> <p><b>NOTES:</b></p> <ol style="list-style-type: none"> <li>1. Programming these bits with values that are invalid (e.g., selecting RAID when in combined mode) will result in indeterministic behavior by the hardware.</li> <li>2. SW shall not manipulate MV during runtime operation; i.e. the OS will not do this. The BIOS may choose to switch from one mode to another during POST.</li> </ol>



### 12.1.34 PCS—Port Control and Status Register (SATA–D31:F2)

Address Offset: 92h–93h    Attribute:    R/W, R/WC, RO  
 Default Value: 0000h    Size:    16 bits

By default, the SATA ports are set to the disabled state (bits [5:0] = '0'). When enabled by software, the ports can transition between the on, partial, and slumber states and can detect devices. When disabled, the port is in the "off" state and cannot detect any devices.

If an AHCI-aware or RAID enabled operating system is being booted then system BIOS shall ensure that all supported SATA ports are enabled prior to passing control to the OS. Once the AHCI aware OS is booted it becomes the enabling/disabling policy owner for the individual SATA ports. This is accomplished by manipulating a port's PxSCTL and PxCMD fields. Because an AHCI or RAID aware OS will typically not have knowledge of the PxE bits and because the PxE bits act as master on/off switches for the ports, pre-boot software must ensure that these bits are set to '1' prior to booting the OS, regardless as to whether or not a device is currently on the port.

Bits	Description
15	<b>OOB Retry Mode (ORM)</b> — R/W. 0 = The SATA controller will not retry after an OOB failure 1 = The SATA controller will continue to retry after an OOB failure until successful (infinite retry)
14	Reserved.
13	<b>Port 5 Present (P5P)</b> — RO. The status of this bit may change at any time. This bit is cleared when the port is disabled via P5E. This bit is not cleared upon surprise removal of a device. 0 = No device detected. 1 = The presence of a device on Port 3 has been detected.
12	<b>Port 4 Present (P4P)</b> — RO. The status of this bit may change at any time. This bit is cleared when the port is disabled via P4E. This bit is not cleared upon surprise removal of a device. 0 = No device detected. 1 = The presence of a device on Port 3 has been detected.
11	<b>Port 3 Present (P3P)</b> — RO. The status of this bit may change at any time. This bit is cleared when the port is disabled via P3E. This bit is not cleared upon surprise removal of a device. 0 = No device detected. 1 = The presence of a device on Port 3 has been detected.
10	<b>Port 2 Present (P2P)</b> — RO. The status of this bit may change at any time. This bit is cleared when the port is disabled via P2E. This bit is not cleared upon surprise removal of a device. 0 = No device detected. 1 = The presence of a device on Port 2 has been detected.
9	<b>Port 1 Present (P1P)</b> — RO. The status of this bit may change at any time. This bit is cleared when the port is disabled via P1E. This bit is not cleared upon surprise removal of a device. 0 = No device detected. 1 = The presence of a device on Port 1 has been detected.



Bits	Description
8	<p><b>Port 0 Present (POP)</b> — RO. The status of this bit may change at any time. This bit is cleared when the port is disabled via POE. This bit is not cleared upon surprise removal of a device.</p> <p>0 = No device detected. 1 = The presence of a device on Port 0 has been detected.</p>
7:6	Reserved
5	<p><b>Port 5 Enabled (P5E)</b> — R/W.</p> <p>0 = Disabled. The port is in the 'off' state and cannot detect any devices. 1 = Enabled. The port can transition between the on, partial, and slumber states and can detect devices.</p> <p><b>NOTE:</b> This bit takes precedence over P5CMD.SUD (offset ABAR+298h:bit 1)</p>
4	<p><b>Port 4 Enabled (P4E)</b> — R/W.</p> <p>0 = Disabled. The port is in the 'off' state and cannot detect any devices. 1 = Enabled. The port can transition between the on, partial, and slumber states and can detect devices.</p> <p><b>NOTE:</b> This bit takes precedence over P4CMD.SUD (offset ABAR+298h:bit 1)</p>
3	<p><b>Port 3 Enabled (P3E)</b> — R/W.</p> <p>0 = Disabled. The port is in the 'off' state and cannot detect any devices. 1 = Enabled. The port can transition between the on, partial, and slumber states and can detect devices.</p> <p><b>NOTE:</b> This bit takes precedence over P3CMD.SUD (offset ABAR+298h:bit 1)</p>
2	<p><b>Port 2 Enabled (P2E)</b> — R/W.</p> <p>0 = Disabled. The port is in the 'off' state and cannot detect any devices. 1 = Enabled. The port can transition between the on, partial, and slumber states and can detect devices.</p> <p><b>NOTE:</b> This bit takes precedence over P2CMD.SUD (offset ABAR+218h:bit 1)</p>
1	<p><b>Port 1 Enabled (P1E)</b> — R/W.</p> <p>0 = Disabled. The port is in the 'off' state and cannot detect any devices. 1 = Enabled. The port can transition between the on, partial, and slumber states and can detect devices.</p> <p><b>NOTE:</b> This bit takes precedence over P1CMD.SUD (offset ABAR+198h:bit 1)</p>
0	<p><b>Port 0 Enabled (POE)</b> — R/W.</p> <p>0 = Disabled. The port is in the 'off' state and cannot detect any devices. 1 = Enabled. The port can transition between the on, partial, and slumber states and can detect devices.</p> <p><b>NOTE:</b> This bit takes precedence over POCMD.SUD (offset ABAR+118h:bit 1)</p>





### 12.1.35 SCLKCG—SATA Clock Gating Control Register

Address Offset: 94h-97h  
 Default Value: 00000000h

Attribute: R/W  
 Size: 32 bits

Bit	Description
31	Reserved
30	<b>SATA Clock Request Enabled (SCRE)</b> — R/W. 0 = SATA Clock Request protocol is disabled. SATACLKREQ# pin when in native function will always output '0' to keep the SATA clock running. 1 = SATA Clock Request protocol is enabled. SATACLKREQ# pin when in native function will behave as the Serial ATA clock request to the system clock chip.
28	Reserved
27:24 (Desktop Only)	Reserved
27:24 (Mobile Only)	<b>SATA Initialization Field 3 (SIF3)</b> — R/W. BIOS shall always program this register to the value 0Ah. All other values are reserved.
23	<b>SATA Initialization Field 2 (SIF2)</b> — R/W. BIOS shall always program this register to the value 0b. All other values are reserved.
22:9	Reserved
8:0	<b>SATA Initialization Field 1 (SIF1)</b> — R/W. BIOS shall always program this register to the value 180h. All other values are reserved.



### 12.1.36 SCLKGC—SATA Clock General Configuration Register

Address Offset: 9Ch Attribute: R/W  
Default Value: 00h Size: 8 bits

Bit	Description
7:2	Reserved
1	<p><b>SATA2-port Configuration Indicator (SATA2PIND)</b> — RO.</p> <p>0 = Normal configuration. 1 = One IDE Controller is implemented supporting only two ports for a Primary Master and a Secondary Master.</p> <p><b>NOTE:</b> When set, BIOS must ensure that bit 2 and bit 3 of the AHCI PI registers are zeros. BIOS must also make sure that Port 2 and Port 3 are disabled (via PCS configuration register) and the port clocks are gated (via SCLKCG configuration register).</p>
0	<p><b>SATA4-port All Master Configuration Indicator (SATA4PMIND)</b> — RO.</p> <p>0 = Normal configuration. 1 = Two IDE Controllers are implemented, each supporting only two ports for a Primary Master and a Secondary Master.</p> <p><b>NOTE:</b> When set, BIOS must ensure that bit 2 and bit 3 of the AHCI PI registers are zeros. BIOS must also make sure that Port 2 and Port 3 are disabled (via PCS configuration register) and the port clocks are gated (via SCLKCG configuration register).</p>

### 12.1.37 SIRI—SATA Indexed Registers Index Register

Address Offset: A0h Attribute: R/W  
Default Value: 00h Size: 8 bits

Bit	Description
7:2	<b>Index (IDX)</b> — R/W. This field is a 5-bit index pointer into the SATA Indexed Register space. Data is written into and read from the SIRI register (D31:F2:A4h).
1:0	Reserved

### 12.1.38 STRD—SATA Indexed Register Data Register

Address Offset: A4h Attribute: R/W  
Default Value: XXXXXXXXh Size: 32 bits

Bit	Description
31:0	<b>Data (DTA)</b> — R/W. 32-bit data value that is written to the register pointed to by SIRI (D31:F2:A0h) or read from the register pointed to by SIRI.



Table 122. SATA Indexed Registers

Index	Name
00h–03h	SATA TX Termination Test Register 1 (STTT1)
04h–17h	Reserved
18h–1Bh	SATA Initialization Register 18 (SIR18)
1Ch–1Fh	SATA Test Mode Enable Register (STME)
20h–27h	Reserved
28h–2Bh	SATA Initialization Register 28 (SIR28)
40h–43h	SATA Initialization Register 40 (SIR40)
44h–73h	Reserved
74h–77h	SATA TX Termination Test Register 2 (STTT2)
78h–7Bh	SATA Initialization Register 78 (SIR78)
7Ch–83h	Reserved
84h–87h	SATA Initialization Register 84 (SIR84)
88h–8Bh	SATA Initialization Register 88 (SIR88)
8Ch–8Fh	SATA Initialization Register 8C (SIR8C)
90h–93h	SATA TX Termination Test Register 3 (STTT3)
94h–97h	SATA Initialization Register 94 (SIR94)
98h–9Fh	Reserved
A0h–A3h	SATA Initialization Register A0 (SIRA0)
A4h–A7h	Reserved
A8h–ABh	SATA Initialization Register A8 (SIRA8)
AC–AFh	SATA Initialization Register AC (SIRAF)



### 12.1.39 STTT1—SATA Indexed Registers Index 00h (SATA TX Termination Test Register 1)

Address Offset: Index 00h - 03h      Attribute: R/W  
Default Value: 00000000h      Size: 32 bits

Bit	Description
31:2	Reserved.
1	<b>Port 1 TX Termination Test Enable</b> — R/W: 0 = Port 1 TX termination port testing is disabled. 1 = Setting this bit will enable testing of Port 1 TX termination.  <b>Note:</b> This bit only to be used for system board testing.
0	<b>Port 0 TX Termination Test Enable</b> — R/W: 0 = Port 0 TX termination port testing is disabled. 1 = Setting this bit will enable testing of Port 0 TX termination.  <b>Note:</b> This bit only to be used for system board testing.

### 12.1.40 SIR18—SATA Indexed Registers Index 18h (SATA Initialization Register 18h)

Address Offset: Index 18h - 1Bh      Attribute: R/W  
Default Value: 0000025Bh      Size: 32 bits

Bit	Description
31:10	Reserved.
9:0	BIOS programs this field to 1000011011b.

### 12.1.41 STME—SATA Indexed Registers Index 1Ch (SATA Test Mode Enable Register)

Address Offset: Index 1Ch - 1Fh      Attribute: R/W  
Default Value: 00000000h      Size: 32 bits

Bit	Description
31:19	Reserved.
18	<b>SATA Test Mode Enable Bit</b> — R/W: 0 = Entrance to Intel ICH6 SATA test modes are disabled. 1 = This bit allows entrance to Intel ICH6 SATA test modes when set.  <b>Note:</b> This bit only to be used for system board testing.
17:0	Reserved.



### 12.1.42 SIR28—SATA Indexed Registers Index 28h (SATA Initialization Register 28h)

Address Offset: Index 28h - 2Bh      Attribute: R/W  
 Default Value: 00CC2080h      Size: 32 bits

Bit	Description
31:0	BIOS programs this field to 00CC2080h.

### 12.1.43 SIR40—SATA Indexed Registers Index 40h (SATA Initialization Register 40h)

Address Offset: Index 40h - 43h      Attribute: R/W  
 Default Value: 0011006Dh      Size: 32 bits

Bit	Description
31:24	Reserved
23:16	BIOS programs this field to 22h.
15:0	Reserved

### 12.1.44 STTT2—SATA Indexed Registers Index 74h (SATA TX Termination Test Register 2)

Address Offset: Index 74h - 77h      Attribute: R/W  
 Default Value: 00000000h      Size: 32 bits

Bit	Description
31:18	Reserved.
17	<p><b>Port 3 TX Termination Test Enable</b> — R/W:            0 = Port 3 TX termination port testing is disabled.            1 = Setting this bit will enable testing of Port 3 TX termination.</p> <p><b>Note:</b> This bit only to be used for system board testing.</p>
16	<p><b>Port 2 TX Termination Test Enable</b> — R/W:            0 = Port 2 TX termination port testing is disabled.            1 = Setting this bit will enable testing of Port 2 TX termination.</p> <p><b>Note:</b> This bit only to be used for system board testing.</p>
15:0	Reserved.



### 12.1.45 SIR78—SATA Indexed Registers Index 78h (SATA Initialization Register 78h)

Address Offset: Index 78h - 7Bh      Attribute: R/W  
Default Value: 00330000h      Size: 32 bits

Bit	Description
31:24	Reserved
23:16	BIOS programs this field to 22h.
15:0	Reserved

### 12.1.46 SIR84—SATA Indexed Registers Index 84h (SATA Initialization Register 84h)

Address Offset: Index 84h - 87h      Attribute: R/W  
Default Value: 0000001Bh      Size: 32 bits

Bit	Description
31:0	BIOS programs this field to 0000001Bh.

### 12.1.47 SIR88—SATA Indexed Registers Index 88h (SATA Initialization Register 88h)

Address Offset: Index 88h - 8Bh      Attribute: R/W  
Default Value: 2D2D2424h      Size: 32 bits

Bit	Description
31:0	BIOS programs this field to 24242424h.

### 12.1.48 SIR8C—SATA Indexed Registers Index 8Ch (SATA Initialization Register 8Ch)

Address Offset: Index 8Ch - 8Fh      Attribute: R/W  
Default Value: 24240055h      Size: 32 bits

Bit	Description
31:0	BIOS programs this field to 090900AAh.



### 12.1.49 STTT3—SATA Indexed Registers Index 90h (SATA TX Termination Test Register 3)

Address Offset: Index 90h - 93h      Attribute: R/W  
 Default Value: 00000000h      Size: 32 bits

Bit	Description
31:2	Reserved.
1	<p><b>Port 5 TX Termination Test Enable</b> — R/W:            0 = Port 1 TX termination port testing is disabled.            1 = Setting this bit will enable testing of Port 1 TX termination.</p> <p><b>NOTE:</b> This bit only to be used for system board testing.</p>
0	<p><b>Port 4 TX Termination Test Enable</b> — R/W:            0 = Port 0 TX termination port testing is disabled.            1 = Setting this bit will enable testing of Port 0 TX termination.</p> <p><b>NOTE:</b> This bit only to be used for system board testing.</p>

### 12.1.50 SIR94—SATA Indexed Registers Index 94h (SATA Initialization Register 94h)

Address Offset: Index 94h - 97h      Attribute: R/W  
 Default Value: 00000011h      Size: 32 bits

Bit	Description
31:0	BIOS programs this field to 00000022h.

### 12.1.51 SIRA0—SATA Indexed Registers Index A0h (SATA Initialization Register A0h)

Address Offset: Index A0h - A3h      Attribute: R/W  
 Default Value: 0000001Bh      Size: 32 bits

Bit	Description
31:0	BIOS programs this field to 0000001Bh.

### 12.1.52 SIRA8—SATA Indexed Registers Index A8h (SATA Initialization Register A8h)

Address Offset: Index A8h - ABh      Attribute: R/W  
 Default Value: 002D0024h      Size: 32 bits

Bit	Description
31:0	BIOS programs this field to 00240024h.



### 12.1.53 SIRAC—SATA Indexed Registers Index ACh (SATA Initialization Register ACh)

Address Offset: Index ACh - AFh                      Attribute: R/W  
Default Value: 00240005h                      Size: 32 bits

Bit	Description
31:0	BIOS programs this field to 0009000Ah.

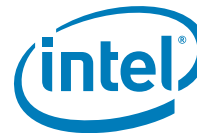
### 12.1.54 SATACRO—SATA Capability Register 0 (SATA–D31:F2)

Address Offset: A8h–ABh                      Attribute: RO  
Default Value: 00100012h                      Size: 32 bits

**Note:** This register shall be read-only 0 when CC.SCC is 01h.

Bit	Description
31:24	Reserved
23:20	Major Revision (MAJREV) — RO: Major revision number of the SATA Capability Pointer implemented.
19:16	Minor Revision (MINREV) — RO: Minor revision number of the SATA Capability Pointer implemented.
15:8	Next Capability Pointer (NEXT) — RO: Points to the next capability structure. 00h indicates this is the last capability pointer.
7:0	Capability ID (CAP)— RO: This value of 12h has been assigned by the PCI SIG to designate the SATA Capability Structure.





### 12.1.55 SATACR1—SATA Capability Register 1 (SATA–D31:F2)

Address Offset: ACh–AFh                                Attribute: RO  
 Default Value: 00000048h                            Size: 32 bits

**Note:** This register shall be read-only 0 when CC.SCC is 01h.

Bit	Description
31:16	Reserved
15:4	<p><b>BAR Offset (BAROFST)</b> — RO: Indicates the offset into the BAR where the Index/Data pair are located (in Dword granularity). The Index and Data I/O registers are located at offset 10h within the I/O space defined by LBAR. A value of 004h indicates offset 10h.</p> <p>000h = 0h offset            001h = 4h offset            002h = 8h offset            003h = Bh offset            004h = 10h offset            ...            FFFh = 3FFFh offset (max 16KB)</p>
3:0	<p><b>BAR Location (BARLOC)</b> — RO: Indicates the absolute PCI Configuration Register address of the BAR containing the Index/Data pair (in Dword granularity). The Index and Data I/O registers reside within the space defined by LBAR in the SATA controller. A value of 8h indicates offset 20h, which is LBAR.</p> <p>0000 – 0011b = reserved            0100b = 10h =&gt; BAR0            0101b = 14h =&gt; BAR1            0110b = 18h =&gt; BAR2            0111b = 1Ch =&gt; BAR3            1000b = 20h =&gt; LBAR            1001b = 24h =&gt; BAR5            1010 – 1110b = reserved            1111b = Index/Data pair in PCI Configuration space. This isn't supported in ICH8.</p>



### 12.1.56 ATC—APM Trapping Control Register (SATA—D31:F2)

Address Offset: C0h                                  Attribute: R/W  
Default Value: 00h                                 Size: 8 bits

Bit	Description
7:4	Reserved
3	<b>Secondary Slave Trap (SST)</b> — R/W. Enables trapping and SMI# assertion on legacy I/O accesses to 170h-177h and 376h. The active device on the secondary interface must be device 1 for the trap and/or SMI# to occur.
2	<b>Secondary Master Trap (SPT)</b> — R/W. Enables trapping and SMI# assertion on legacy I/O accesses to 170h-177h and 376h. The active device on the secondary interface must be device 0 for the trap and/or SMI# to occur.
1	<b>Primary Slave Trap (PST)</b> — R/W. Enables trapping and SMI# assertion on legacy I/O accesses to 1F0h-1F7h and 3F6h. The active device on the primary interface must be device 1 for the trap and/or SMI# to occur.
0	<b>Primary Master Trap (PMT)</b> — R/W. Enables trapping and SMI# assertion on legacy I/O accesses to 1F0h-1F7h and 3F6h. The active device on the primary interface must be device 0 for the trap and/or SMI# to occur.

### 12.1.57 ATS—APM Trapping Status Register (SATA—D31:F2)

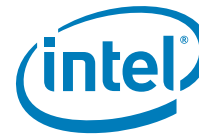
Address Offset: C4h                                  Attribute: R/WC  
Default Value: 00h                                 Size: 8 bits

Bit	Description
7:4	Reserved
3	<b>Secondary Slave Trap (SST)</b> — R/WC. Indicates that a trap occurred to the secondary slave device.
2	<b>Secondary Master Trap (SPT)</b> — R/WC. Indicates that a trap occurred to the secondary master device.
1	<b>Primary Slave Trap (PST)</b> — R/WC. Indicates that a trap occurred to the primary slave device.
0	<b>Primary Master Trap (PMT)</b> — R/WC. Indicates that a trap occurred to the primary master device.

### 12.1.58 SP Scratch Pad Register (SATA—D31:F2)

Address Offset: D0h                                  Attribute: R/W  
Default Value: 00000000h                         Size: 32 bits

Bit	Description
31:0	<b>Data (DT)</b> — R/W. This is a read/write register that is available for software to use. No hardware action is taken on this register.



## 12.1.59 BFCS—BIST FIS Control/Status Register (SATA–D31:F2)

Address Offset: E0h–E3h                      Attribute: R/W, R/WC  
Default Value: 00000000h                  Size: 32 bits

Bits	Description
31:16	Reserved
15 (Desktop Only)	<b>Port 5 BIST FIS Initiate (P5BFI)</b> — R/W. When a rising edge is detected on this bit field, the ICH8 initiates a BIST FIS to the device on Port 5, using the parameters specified in this register and the data specified in BFTD1 and BFTD2. The BIST FIS will only be initiated if a device on Port 5 is present and ready (not partial/slumber state). After a BIST FIS is successfully completed, software must disable and re-enable the port using the PxE bits at offset 92h prior to attempting additional BIST FISs or to return the ICH8 to a normal operational mode. If the BIST FIS fails to complete, as indicated by the BFF bit in the register, then software can clear then set the P5BFI bit to initiate another BIST FIS. This can be retried until the BIST FIS eventually completes successfully
14 (Desktop Only)	<b>Port 4 BIST FIS Initiate (P4BFI)</b> — R/W. When a rising edge is detected on this bit field, the ICH8 initiates a BIST FIS to the device on Port 4, using the parameters specified in this register and the data specified in BFTD1 and BFTD2. The BIST FIS will only be initiated if a device on Port 4 is present and ready (not partial/slumber state). After a BIST FIS is successfully completed, software must disable and re-enable the port using the PxE bits at offset 92h prior to attempting additional BIST FISs or to return the ICH8 to a normal operational mode. If the BIST FIS fails to complete, as indicated by the BFF bit in the register, then software can clear then set the P4BFI bit to initiate another BIST FIS. This can be retried until the BIST FIS eventually completes successfully
13 (Desktop Only)	<b>Port 3 BIST FIS Initiate (P3BFI)</b> — R/W. When a rising edge is detected on this bit field, the ICH8 initiates a BIST FIS to the device on Port 3, using the parameters specified in this register and the data specified in BFTD1 and BFTD2. The BIST FIS will only be initiated if a device on Port 3 is present and ready (not partial/slumber state). After a BIST FIS is successfully completed, software must disable and re-enable the port using the PxE bits at offset 92h prior to attempting additional BIST FISs or to return the ICH8 to a normal operational mode. If the BIST FIS fails to complete, as indicated by the BFF bit in the register, then software can clear then set the P3BFI bit to initiate another BIST FIS. This can be retried until the BIST FIS eventually completes successfully
13 (Mobile Only)	Reserved.
12	<b>Port 2 BIST FIS Initiate (P2BFI)</b> — R/W. When a rising edge is detected on this bit field, the ICH8 initiates a BIST FIS to the device on Port 2, using the parameters specified in this register and the data specified in BFTD1 and BFTD2. The BIST FIS will only be initiated if a device on Port 2 is present and ready (not partial/slumber state). After a BIST FIS is successfully completed, software must disable and re-enable the port using the PxE bits at offset 92h prior to attempting additional BIST FISes or to return the ICH8 to a normal operational mode. If the BIST FIS fails to complete, as indicated by the BFF bit in the register, then software can clear then set the P2BFI bit to initiate another BIST FIS. This can be retried until the BIST FIS eventually completes successfully
11	<b>BIST FIS Successful (BFS)</b> — R/WC. 0 = Software clears this bit by writing a 1 to it. 1 = This bit is set any time a BIST FIS transmitted by ICH8 receives an R_OK completion status from the device. <b>NOTE:</b> This bit must be cleared by software prior to initiating a BIST FIS.



Bits	Description
10	<p><b>BIST FIS Failed (BFF)</b> — R/WC.            0 = Software clears this bit by writing a 1 to it.            1 = This bit is set any time a BIST FIS transmitted by ICH8 receives an R_ERR completion status from the device.</p> <p><b>NOTE:</b> This bit must be cleared by software prior to initiating a BIST FIS.</p>
9 (Desktop Only)	<p><b>Port 1 BIST FIS Initiate (P1BFI)</b> — R/W. When a rising edge is detected on this bit field, the ICH8 initiates a BIST FIS to the device on Port 1, using the parameters specified in this register and the data specified in BFTD1 and BFTD2. The BIST FIS will only be initiated if a device on Port 1 is present and ready (not partial/slumber state). After a BIST FIS is successfully completed, software must disable and re-enable the port using the PxE bits at offset 92h prior to attempting additional BIST FISes or to return the ICH8 to a normal operational mode. If the BIST FIS fails to complete, as indicated by the BFF bit in the register, then software can clear then set the P1BFI bit to initiate another BIST FIS. This can be retried until the BIST FIS eventually completes successfully</p>
9 (Mobile Only)	Reserved.
8	<p><b>Port 0 BIST FIS Initiate (POBFI)</b> — R/W. When a rising edge is detected on this bit field, the ICH8 initiates a BIST FIS to the device on Port 0, using the parameters specified in this register and the data specified in BFTD1 and BFTD2. The BIST FIS will only be initiated if a device on Port 0 is present and ready (not partial/slumber state). After a BIST FIS is successfully completed, software must disable and re-enable the port using the PxE bits at offset 92h prior to attempting additional BIST FISes or to return the ICH8 to a normal operational mode. If the BIST FIS fails to complete, as indicated by the BFF bit in the register, then software can clear then set the POBFI bit to initiate another BIST FIS. This can be retried until the BIST FIS eventually completes successfully</p>
7:2	<p><b>BIST FIS Parameters.</b> These 6 bits form the contents of the upper 6 bits of the BIST FIS Pattern Definition in any BIST FIS transmitted by the ICH8. This field is not port specific — its contents will be used for any BIST FIS initiated on port 0, port 1, port 2 or port 3. The specific bit definitions are:</p> <p>Bit 7: T – Far End Transmit mode            Bit 6: A – Align Bypass mode            Bit 5: S – Bypass Scrambling            Bit 4: L – Far End Retimed Loopback            Bit 3: F – Far End Analog Loopback            Bit 2: P – Primitive bit for use with Transmit mode</p>
1:0	Reserved



### 12.1.60 BFTD1—BIST FIS Transmit Data1 Register (SATA–D31:F2)

Address Offset: E4h–E7h                      Attribute:              R/W  
 Default Value: 00000000h                  Size:                    32 bits

Bits	Description
31:0	<b>BIST FIS Transmit Data 1</b> — R/W. The data programmed into this register will form the contents of the second dword of any BIST FIS initiated by the ICH8. This register is not port specific — its contents will be used for BIST FIS initiated on any port. Although the 2nd and 3rd DWs of the BIST FIS are only meaningful when the “T” bit of the BIST FIS is set to indicate “Far-End Transmit mode”, this register’s contents will be transmitted as the BIST FIS 2nd DW regardless of whether or not the “T” bit is indicated in the BFCS register (D31:F2:E0h).

### 12.1.61 BFTD2—BIST FIS Transmit Data2 Register (SATA–D31:F2)

Address Offset: E8h–EBh                      Attribute:              R/W  
 Default Value: 00000000h                  Size:                    32 bits

Bits	Description
31:0	<b>BIST FIS Transmit Data 2</b> — R/W. The data programmed into this register will form the contents of the third dword of any BIST FIS initiated by the ICH8. This register is not port specific — its contents will be used for BIST FIS initiated on any port. Although the 2nd and 3rd DWs of the BIST FIS are only meaningful when the “T” bit of the BIST FIS is set to indicate “Far-End Transmit mode”, this register’s contents will be transmitted as the BIST FIS 3rd DW regardless of whether or not the “T” bit is indicated in the BFCS register (D31:F2:E0h).



## 12.2 Bus Master IDE I/O Registers (D31:F2)

The bus master IDE function uses 16 bytes of I/O space, allocated via the BAR register, located in Device 31:Function 2 Configuration space, offset 20h. All bus master IDE I/O space registers can be accessed as byte, word, or dword quantities. Reading reserved bits returns an indeterminate, inconsistent value, and writes to reserved bits have no affect (but should not be attempted). These registers are only used for legacy operation. Software must not use these registers when running AHCI. The description of the I/O registers is shown in [Table 123](#).

**Table 123. Bus Master IDE I/O Register Address Map**

BAR+ Offset	Mnemonic	Register	Default	Type
00	BMICP	Command Register Primary	00h	R/W
01	—	Reserved	—	RO
02	BMISP	Bus Master IDE Status Register Primary	00h	R/W, R/WC, RO
03	—	Reserved	—	RO
04–07	BMIDP	Bus Master IDE Descriptor Table Pointer Primary	xxxxxxxxh	R/W
08	BMICS	Command Register Secondary	00h	R/W
09	—	Reserved	—	RO
0Ah	BMISS	Bus Master IDE Status Register Secondary	00h	R/W, R/WC, RO
0Bh	—	Reserved	—	RO
0Ch–0Fh	BMIDS	Bus Master IDE Descriptor Table Pointer Secondary	xxxxxxxxh	R/W
10h	AIR	AHCI Index Register	0000000h	R/W, RO
14h	AIDR	AHCI Index Data Register	xxxxxxxxh	R/W



## 12.2.1 BMIC[P,S]—Bus Master IDE Command Register (D31:F2)

Address Offset: Primary: BAR + 00h      Attribute: R/W  
 Secondary: BAR + 08h  
 Default Value: 00h      Size: 8 bits

Bit	Description
7:4	Reserved. Returns 0.
3	<p><b>Read / Write Control (R/WC)</b> — R/W. This bit sets the direction of the bus master transfer: This bit must NOT be changed when the bus master function is active.</p> <p>0 = Memory reads            1 = Memory writes</p>
2:1	Reserved. Returns 0.
0	<p><b>Start/Stop Bus Master (START)</b> — R/W.</p> <p>0 = All state information is lost when this bit is cleared. Master mode operation cannot be stopped and then resumed. If this bit is reset while bus master operation is still active (i.e., the Bus Master IDE Active bit (D31:F2:BAR + 02h, bit 0) of the Bus Master IDE Status register for that IDE channel is set) and the drive has not yet finished its data transfer (the Interrupt bit in the Bus Master IDE Status register for that IDE channel is not set), the bus master command is said to be aborted and data transferred from the drive may be discarded instead of being written to system memory.</p> <p>1 = Enables bus master operation of the controller. Bus master operation does not actually start unless the Bus Master Enable bit (D31:F1:04h, bit 2) in PCI configuration space is also set. Bus master operation begins when this bit is detected changing from 0 to 1. The controller will transfer data between the IDE device and memory only when this bit is set. Master operation can be halted by writing a 0 to this bit.</p> <p><b>NOTE:</b> This bit is intended to be cleared by software after the data transfer is completed, as indicated by either the Bus Master IDE Active bit being cleared or the Interrupt bit of the Bus Master IDE Status register for that IDE channel being set, or both. Hardware does not clear this bit automatically. If this bit is cleared to 0 prior to the DMA data transfer being initiated by the drive in a</p>



### 12.2.2 BMIS[P,S]—Bus Master IDE Status Register (D31:F2)

Address Offset: Primary: BAR + 02h      Attribute: R/W, R/WC, RO  
 Secondary: BAR + 0Ah  
 Default Value: 00h      Size: 8 bits

Bit	Description
7	<b>PRD Interrupt Status (PRDIS)</b> — R/WC. 0 = Software clears this bit by writing a 1 to it. 1 = This bit is set when the host controller execution of a PRD that has its PRD_INT bit set.
6	<b>Drive 1 DMA Capable</b> — R/W. 0 = Not Capable. 1 = Capable. Set by device dependent code (BIOS or device driver) to indicate that drive 1 for this channel is capable of DMA transfers, and that the controller has been initialized for optimum performance. The Intel® ICH8 does not use this bit. It is intended for systems that do not attach BMIDE to the PCI bus.
5	<b>Drive 0 DMA Capable</b> — R/W. 0 = Not Capable 1 = Capable. Set by device dependent code (BIOS or device driver) to indicate that drive 0 for this channel is capable of DMA transfers, and that the controller has been initialized for optimum performance. The ICH8 does not use this bit. It is intended for systems that do not attach BMIDE to the PCI bus.
4:3	Reserved. Returns 0.
2	<b>Interrupt</b> — R/WC. 0 = Software clears this bit by writing a 1 to it. 1 = Set when a device FIS is received with the 'I' bit set, provided that software has not disabled interrupts via the IEN bit of the Device Control Register (see chapter 5 of the <i>Serial ATA Specification</i> , Revision 2.5).
1	<b>Error</b> — R/WC. 0 = Software clears this bit by writing a 1 to it. 1 = This bit is set when the controller encounters a target abort or master abort when transferring data on PCI.
0	<b>Bus Master IDE Active (ACT)</b> — RO. 0 = This bit is cleared by the ICH8 when the last transfer for a region is performed, where EOT for that region is set in the region descriptor. It is also cleared by the ICH8 when the Start Bus Master bit (D31:F2:BAR+ 00h, bit 0) is cleared in the Command register. When this bit is read as a 0, all data transferred from the drive during the previous bus master command is visible in system memory, unless the bus master command was aborted. 1 = Set by the ICH8 when the Start bit is written to the Command register.





### 12.2.3 BMID[P,S]—Bus Master IDE Descriptor Table Pointer Register (D31:F5)

Address Offset: Primary: BAR + 04h–07h Attribute: R/W  
 Secondary: BAR + 0Ch–0Fh  
 Default Value: All bits undefined Size: 32 bits

Bit	Description
31:2	<b>Address of Descriptor Table (ADDR)</b> — R/W. The bits in this field correspond to bits [31:2] of the memory location of the Physical Region Descriptor (PRD). The Descriptor Table must be dword-aligned. The Descriptor Table must not cross a 64-KB boundary in memory.
1:0	Reserved

#### 12.2.3.1 PxSSTS—Serial ATA Status Register (D31:F5)

Address Offset: BAR + 00h Attribute: RO  
 Default Value: 00000000h Size: 32 bits

This is a 32-bit register that conveys the current state of the interface and host. The ICH8 updates it continuously and asynchronously. When the ICH8 transmits a COMRESET to the device, this register is updated to its reset values.

Bit	Description
31:12	Reserved



Bit	Description										
11:8	<p><b>Interface Power Management (IPM)</b> — RO. Indicates the current interface state:</p> <table border="0"> <thead> <tr> <th style="text-align: left;">Value</th> <th style="text-align: left;">Description</th> </tr> </thead> <tbody> <tr> <td>0h</td> <td>Device not present or communication not established</td> </tr> <tr> <td>1h</td> <td>Interface in active state</td> </tr> <tr> <td>2h</td> <td>Interface in PARTIAL power management state</td> </tr> <tr> <td>6h</td> <td>Interface in SLUMBER power management state</td> </tr> </tbody> </table> <p>All other values reserved.</p>	Value	Description	0h	Device not present or communication not established	1h	Interface in active state	2h	Interface in PARTIAL power management state	6h	Interface in SLUMBER power management state
Value	Description										
0h	Device not present or communication not established										
1h	Interface in active state										
2h	Interface in PARTIAL power management state										
6h	Interface in SLUMBER power management state										
7:4	<p><b>Current Interface Speed (SPD)</b> — RO. Indicates the negotiated interface communication speed.</p> <table border="0"> <thead> <tr> <th style="text-align: left;">Value</th> <th style="text-align: left;">Description</th> </tr> </thead> <tbody> <tr> <td>0h</td> <td>Device not present or communication not established</td> </tr> <tr> <td>1h</td> <td>Generation 1 communication rate negotiated</td> </tr> <tr> <td>2h</td> <td>Generation 2 communication rate negotiated</td> </tr> </tbody> </table> <p>All other values reserved.            ICH8 Supports Generation 1 communication rates (1.5 Gb/sec) and Gen 2 rates (3.0 Gb/s).</p>	Value	Description	0h	Device not present or communication not established	1h	Generation 1 communication rate negotiated	2h	Generation 2 communication rate negotiated		
Value	Description										
0h	Device not present or communication not established										
1h	Generation 1 communication rate negotiated										
2h	Generation 2 communication rate negotiated										
3:0	<p><b>Device Detection (DET)</b> — RO. Indicates the interface device detection and Phy state:</p> <table border="0"> <thead> <tr> <th style="text-align: left;">Value</th> <th style="text-align: left;">Description</th> </tr> </thead> <tbody> <tr> <td>0h</td> <td>No device detected and Phy communication not established</td> </tr> <tr> <td>1h</td> <td>Device presence detected but Phy communication not established</td> </tr> <tr> <td>3h</td> <td>Device presence detected and Phy communication established</td> </tr> <tr> <td>4h</td> <td>Phy in offline mode as a result of the interface being disabled or running in a BIST loopback mode</td> </tr> </tbody> </table> <p>All other values reserved.</p>	Value	Description	0h	No device detected and Phy communication not established	1h	Device presence detected but Phy communication not established	3h	Device presence detected and Phy communication established	4h	Phy in offline mode as a result of the interface being disabled or running in a BIST loopback mode
Value	Description										
0h	No device detected and Phy communication not established										
1h	Device presence detected but Phy communication not established										
3h	Device presence detected and Phy communication established										
4h	Phy in offline mode as a result of the interface being disabled or running in a BIST loopback mode										



### 12.2.3.2 PxSCTL — Serial ATA Control Register (D31:F5)

Address Offset: BAR + 01h                              Attribute: R/W, RO  
 Default Value: 00000004h                             Size: 32 bits

This is a 32-bit read-write register by which software controls SATA capabilities. Writes to the SControl register result in an action being taken by the ICH8 or the interface. Reads from the register return the last value written to it.

Bit	Description										
31:20	Reserved										
19:16	Port Multiplier Port (PMP) — RO. This field is not used by AHCI <b>NOTE:</b> Port Multiplier not supported by ICH8.										
15:12	Select Power Management (SPM) — RO. This field is not used by AHCI										
11:8	<p><b>Interface Power Management Transitions Allowed (IPM)</b> — R/W. Indicates which power states the ICH8 is allowed to transition to:</p> <table border="1"> <thead> <tr> <th>Value</th> <th>Description</th> </tr> </thead> <tbody> <tr> <td>0h</td> <td>No interface restrictions</td> </tr> <tr> <td>1h</td> <td>Transitions to the PARTIAL state disabled</td> </tr> <tr> <td>2h</td> <td>Transitions to the SLUMBER state disabled</td> </tr> <tr> <td>3h</td> <td>Transitions to both PARTIAL and SLUMBER states disabled</td> </tr> </tbody> </table> <p>All other values reserved</p>	Value	Description	0h	No interface restrictions	1h	Transitions to the PARTIAL state disabled	2h	Transitions to the SLUMBER state disabled	3h	Transitions to both PARTIAL and SLUMBER states disabled
Value	Description										
0h	No interface restrictions										
1h	Transitions to the PARTIAL state disabled										
2h	Transitions to the SLUMBER state disabled										
3h	Transitions to both PARTIAL and SLUMBER states disabled										
7:4	<p><b>Speed Allowed (SPD)</b> — R/W. Indicates the highest allowable speed of the interface. This speed is limited by the CAP.ISS (ABAR+00h:bit 23:20) field.</p> <table border="1"> <thead> <tr> <th>Value</th> <th>Description</th> </tr> </thead> <tbody> <tr> <td>0h</td> <td>No speed negotiation restrictions</td> </tr> <tr> <td>1h</td> <td>Limit speed negotiation to Generation 1 communication rate</td> </tr> <tr> <td>2h</td> <td>Limit speed negotiation to Generation 2 communication rate</td> </tr> </tbody> </table> <p>All other values reserved.            ICH8 Supports Generation 1 communication rates (1.5 Gb/sec) and Gen 2 rates (3.0 Gb/s).</p>	Value	Description	0h	No speed negotiation restrictions	1h	Limit speed negotiation to Generation 1 communication rate	2h	Limit speed negotiation to Generation 2 communication rate		
Value	Description										
0h	No speed negotiation restrictions										
1h	Limit speed negotiation to Generation 1 communication rate										
2h	Limit speed negotiation to Generation 2 communication rate										
3:0	<p><b>Device Detection Initialization (DET)</b> — R/W. Controls the ICH8's device detection and interface initialization.</p> <table border="1"> <thead> <tr> <th>Value</th> <th>Description</th> </tr> </thead> <tbody> <tr> <td>0h</td> <td>No device detection or initialization action requested</td> </tr> <tr> <td>1h</td> <td>Perform interface communication initialization sequence to establish communication. This is functionally equivalent to a hard reset and results in the interface being reset and communications re-initialized</td> </tr> <tr> <td>4h</td> <td>Disable the Serial ATA interface and put Phy in offline mode</td> </tr> </tbody> </table> <p>All other values reserved.            When this field is written to a 1h, the ICH8 initiates COMRESET and starts the initialization process. When the initialization is complete, this field shall remain 1h until set to another value by software.            This field may only be changed to 1h or 4h when PxCMD.ST is 0. Changing this field while the ICH8 is running results in undefined behavior.</p>	Value	Description	0h	No device detection or initialization action requested	1h	Perform interface communication initialization sequence to establish communication. This is functionally equivalent to a hard reset and results in the interface being reset and communications re-initialized	4h	Disable the Serial ATA interface and put Phy in offline mode		
Value	Description										
0h	No device detection or initialization action requested										
1h	Perform interface communication initialization sequence to establish communication. This is functionally equivalent to a hard reset and results in the interface being reset and communications re-initialized										
4h	Disable the Serial ATA interface and put Phy in offline mode										



12.2.3.3 PxSERR—Serial ATA Error Register (D31:F5)

Address Offset: BAR + 02h                      Attribute: R/WC  
 Default Value: 00000000h                    Size: 32 bits

Bit	Description
	<b>Diagnostics (DIAG)</b> — R/WC. Contains diagnostic error information for use by diagnostic software in validating correct operation or isolating failure modes: <b>Bits Description</b> 31:27Reserved 26 <b>Exchanged (X)</b> : When set to one this bit indicates a COMINIT signal was received. This bit is reflected in the interrupt register PxIS.PCS. 25 <b>Unrecognized FIS Type (F)</b> : Indicates that one or more FISs were received by the Transport layer with good CRC, but had a type field that was not recognized. 24 <b>Transport state transition error (T)</b> : Indicates that an error has occurred in the transition from one state to another within the Transport layer since the last time this bit was cleared. 23 <b>Link Sequence Error (S)</b> : Indicates that one or more Link state machine error conditions was encountered. The Link Layer state machine defines the conditions under which the link layer detects an erroneous transition. 31:16 22 <b>Handshake Error (H)</b> : Indicates that one or more R_ERR handshake response was received in response to frame transmission. Such errors may be the result of a CRC error detected by the recipient, a disparity or 8b/10b decoding error, or other error condition leading to a negative handshake on a transmitted frame. 21 <b>CRC Error (C)</b> : Indicates that one or more CRC errors occurred with the Link Layer. 20 <b>Disparity Error (D)</b> : This field is not used by AHCI. 19 <b>10b to 8b Decode Error (B)</b> : Indicates that one or more 10b to 8b decoding errors occurred. 18 <b>Comm Wake (W)</b> : Indicates that a Comm Wake signal was detected by the Phy. 17 <b>Phy Internal Error (I)</b> : Indicates that the Phy detected some internal error. 16 <b>PhyRdy Change (N)</b> : When set to 1, this bit indicates that the internal PhyRdy signal changed state since the last time this bit was cleared. In the ICH8, this bit will be set when PhyRdy changes from a 0 -> 1 or a 1 -> 0. The state of this bit is then reflected in the PxIS.PRCs interrupt status bit and an interrupt will be generated if enabled. Software clears this bit by writing a 1 to it.



Bit	Description
15:0	<p><b>Error (ERR)</b> — R/WC. The ERR field contains error information for use by host software in determining the appropriate response to the error condition. If one or more of bits 11:8 of this register are set, the controller will stop the current transfer.</p> <p><b>Bits Description</b></p> <p>15:12 Reserved</p> <p>11 <b>Internal Error (E)</b>: The SATA controller failed due to a master or target abort when attempting to access system memory.</p> <p>10 <b>Protocol Error (P)</b>: A violation of the Serial ATA protocol was detected. Note: The ICH8 does not set this bit for all protocol violations that may occur on the SATA link.</p> <p>9 <b>Persistent Communication or Data Integrity Error (C)</b>: A communication error that was not recovered occurred that is expected to be persistent. Persistent communications errors may arise from faulty interconnect with the device, from a device that has been removed or has failed, or a number of other causes.</p> <p>8 <b>Transient Data Integrity Error (T)</b>: A data integrity error occurred that was not recovered by the interface.</p> <p>7:2 Reserved</p> <p>1 <b>Recovered Communications Error (M)</b>: Communications between the device and host was temporarily lost but was re-established. This can arise from a device temporarily being removed, from a temporary loss of Phy synchronization, or from other causes and may be derived from the PhyNRdy signal between the Phy and Link layers.</p> <p>0 <b>Recovered Data Integrity Error (I)</b>: A data integrity error occurred that was recovered by the interface through a retry operation or other recovery action.</p>

#### 12.2.4 AIR—AHCI Index Register (D31:F2)

Address Offset: Primary: BAR + 10h      Attribute: R/W, RO  
 Default Value: 00000000h      Size: 32 bits

This register is available only when CC.SCC is not 01h.

Bit	Description
31:11	Reserved
10:2	<b>Index (INDEX)</b> — R/W. This Index register is used to select the DWord offset of the Memory Mapped AHCI register to be accessed. A Dword, Word or Byte access is specified by the active byte enables of the I/O access to the Data register.
1:0	Reserved



### 12.2.5 AIDR—AHCI Index Data Register (D31:F2)

Address Offset: Primary: BAR + 14h      Attribute: R/W  
 Default Value: All bits undefined      Size: 32 bits

This register is available only when CC.SCC is not 01h.

Bit	Description
31:0	<p><b>Data (DATA)</b>— R/W. This Data register is a “window” through which data is read or written to the AHCI memory mapped registers. A read or write to this Data register triggers a corresponding read or write to the memory mapped register pointed to by the Index register. The Index register must be setup prior to the read or write to this Data register.</p> <p>Note that a physical register is not actually implemented as the data is actually stored in the memory mapped registers.</p> <p>Since this is not a physical register, the “default” value is the same as the default value of the register pointed to by Index.</p>

## 12.3 Serial ATA Index/Data Pair Superset Registers

All of these I/O registers are in the core well. They are exposed only when CC.SCC is 01h (i.e., IDE programming interface) and the controller is not in combined mode. These are Index/Data Pair registers that are used to access the SerialATA superset registers (SerialATA Status, SerialATA Control and SerialATA Error). The I/O space for these registers is allocated through SIDPBA. Locations with offset from 08h to 0Fh are reserved for future expansion. Software-write operations to the reserved locations shall have no effect while software-read operations to the reserved locations shall return 0.

### 12.3.1 SINDX—SATA Index Register (D31:F5)

Address Offset: SIDPBA + 00h      Attribute: R/W  
 Default Value: 00000000h      Size: 32 bits

**Note:** These are Index/Data Pair Registers that are used to access the SSTS, SCTL, and SERR. The I/O space for these registers is allocated through SIDPBA.

Bit	Description
31:16	Reserved
15:8	<p><b>Port Index (PIDX)</b>— R/W. This Index field is used to specify the port of the SATA controller at which the port-specific SSTS, SCTL, and SERR registers are located.</p> <p>00h = Primary Master (Port 0)            01h = Primary Slave (Port 2)            02h = Secondary Master (Port 1)            03h = Secondary Slave (Port 3)            All other values are Reserved.</p>
7:0	<p><b>Register Index (RIDX)</b>— R/W. This Index field is used to specify one out of three registers currently being indexed into.</p> <p>00h = SSTS            01h = SCTL            02h = SERR            All other values are Reserved</p>



### 12.3.2 SDATA—SATA Index Data Register (D31:F5)

Address Offset: SIDPBA + 04h                      Attribute: R/W  
 Default Value: All bits undefined              Size: 32 bits

**Note:** These are Index/Data Pair Registers that are used to access the SSTS, SCTL, and SERR. The I/O space for these registers is allocated through SIDPBA.

Bit	Description
31:0	<p><b>Data (DATA)</b>— R/W. This Data register is a “window” through which data is read or written to the memory mapped registers. A read or write to this Data register triggers a corresponding read or write to the memory mapped register pointed to by the Index register. The Index register must be setup prior to the read or write to this Data register.</p> <p>Note that a physical register is not actually implemented as the data is actually stored in the memory mapped registers.</p> <p>Since this is not a physical register, the “default” value is the same as the default value of the register pointed to by Index.</p>



## 12.4 AHCI Registers (D31:F2) (Intel® ICH8R, ICH8DH, ICH8DO, and ICH8M-E Only)

**Note:** These registers are AHCI-specific and available when the ICH8 is properly configured. The Serial ATA Status, Control, and Error registers are special exceptions and may be accessed on all ICH8 components if properly configured. See [Section 12.1.31](#) for details.

The memory mapped registers within the SATA controller exist in non-cacheable memory space. Additionally, locked accesses are not supported. If software attempts to perform locked transactions to the registers, indeterminate results may occur. Register accesses shall have a maximum size of 64-bits; 64-bit access must not cross an 8-byte alignment boundary.

The registers are broken into two sections – generic host control and port control. The port control registers are the same for all ports, and there are as many registers banks as there are ports.

**Table 124. AHCI Register Address Map**

ABAR + Offset	Mnemonic	Register
00–1Fh	GHC	Generic Host Control
20h–FFh	—	Reserved
100h–17Fh	P0PCR	Port 0 port control registers
180h–1FFh	P1PCR	Port 1 port control registers
200h–27Fh	P2PCR	Port 2 port control registers
280h–2FFh	P3PCR	Port 3 port control registers (Desktop Only) Registers are not available and software must not read or write registers. (Mobile Only)
300h–37Fh	P4PCR	Port 4 port control registers (Desktop Only) Registers are not available and software must not read or write registers. (Mobile Only)
380h–3FFh	P5PCR	Port 5 port control registers (Desktop Only) Registers are not available and software must not read or write registers. (Mobile Only)





## 12.4.1 AHCI Generic Host Control Registers (D31:F2)

Table 125. Generic Host Controller Register Address Map

ABAR + Offset	Mnemonic	Register	Default	Type
00–03	CAP	Host Capabilities	DE227F03h (desktop) DE127F03h (mobile)	R/WO, RO
04–07	GHC	Global ICH8 Control	00000000h	R/W
08–0Bh	IS	Interrupt Status	00000000h	R/WC, RO
0Ch–0Fh	PI	Ports Implemented	00000000h	R/WO, RO
10h–13h	VS	AHCI Version	00010100h	RO

### 12.4.1.1 CAP—Host Capabilities Register (D31:F2)

Address Offset: ABAR + 00h–03h      Attribute: R/WO, RO  
 Default Value: FF22FFC2h (Desktop)      Size: 32 bits  
 DE127F03h (Mobile)

All bits in this register that are R/WO are reset only by PLTRST#.

Bit	Description
31	<b>Supports 64-bit Addressing (S64A)</b> — RO. Indicates that the SATA controller can access 64-bit data structures. The 32-bit upper bits of the port DMA Descriptor, the PRD Base, and each PRD entry are read/write.
30	<b>Supports Command Queue Acceleration (SCQA)</b> — RO. Hardwired to 1 to indicate that the SATA controller supports SATA command queuing via the DMA Setup FIS. The Intel® ICH8 handles DMA Setup FISes natively, and can handle auto-activate optimization through that FIS.
29	Supports SNotification Register (SSNTF): — RO. The ICH8 SATA Controller does not support the SNotification register.
28	<b>Supports Interlock Switch (SIS)</b> — R/WO. Indicates whether the SATA controller supports interlock switches on its ports for use in Hot-Plug operations. This value is loaded by platform BIOS prior to OS initialization. If this bit is set, BIOS must also map the SATAGP pins to the SATA controller through GPIO space.
27	<b>Supports Staggered Spin-up (SSS)</b> — R/WO. Indicates whether the SATA controller supports staggered spin-up on its ports, for use in balancing power spikes. This value is loaded by platform BIOS prior to OS initialization. 0 = Staggered spin-up not supported. 1 = Staggered spin-up supported.
26	<b>Supports Aggressive Link Power Management (SALP)</b> — R/WO. 0 = Software shall treat the PxCMD.ALPE and PxCMD.ASP bits as reserved. 1 = The SATA controller supports auto-generating link requests to the partial or slumber states when there are no commands to process.
25	<b>Supports Activity LED (SAL)</b> — RO. Indicates that the SATA controller supports a single output pin (SATALED#) which indicates activity.



Bit	Description
24	<b>Supports Command List Override (SCLO)</b> — R/WO. When set to '1', indicates that the HBA supports the PxCMD.CLO bit and it's associated function. When cleared to '0', The HBA is not capable of clearing the BSY and DRQ bits in the Status register in order to issue a software reset if these bits are still set from a previous operation.
23:20	<b>Interface Speed Support (ISS)</b> — R/WO. Indicates the maximum speed the SATA controller can support on its ports. 2h = 3.0 Gb/s.
19	Supports Non-Zero DMA Offsets (SNZO) — RO. Reserved, as per the AHCI Revision 1.0 specification
18	<b>Supports AHCI Mode Only (SAM)</b> — RO. The SATA controller may optionally support AHCI access mechanism only. 0 = SATA controller supports both IDE and AHCI Modes 1 = SATA controller supports AHCI Mode Only
17	<b>Supports Port Multiplier (PMS)</b> — R/WO. ICH8 does not support port multiplier. BIOS/SW shall write this bit to '0' during AHCI initialization.
16	Supports Port Multiplier FIS Based Switching (PMFS) — RO. Reserved, as per the AHCI Revision 1.0 specification. <b>NOTE:</b> Port Multiplier not supported by ICH8.
15	<b>PIO Multiple DRQ Block (PMD)</b> — R/WO. The SATA controller supports PIO Multiple DRQ Command Block
14	Slumber State Capable (SSC) — RO. The SATA controller supports the slumber state.
13	Partial State Capable (PSC) — RO. The SATA controller supports the partial state.
12:8	Number of Command Slots (NCS) — RO. Hardwired to 1Fh to indicate support for 32 slots.
7	<b>Command Completion Coalescing Supported (CCCS)</b> — R/WO. 0 = Command Completion Coalescing Not Supported 1 = Command Completion Coalescing Supported
6	<b>Enclosure Management Supported (EMS)</b> — R/WO. 0 = Enclosure Management Not Supported 1 = Enclosure Management Supported
5 (ICH8R, ICH8DO, ICH8DH Only)	<b>Supports External SATA (SXS)</b> — R/WO. 0 = External SATA is not supported on any ports 1 = External SATA is supported on one or more ports When set, software can examine each SATA port's Command Register (PxCMD) to determine which port is routed externally.
5	Reserved
5 (ICH8 Base and ICH8 Mobile Only)	Reserved
4:0	Number of Ports (NPS) — RO. Hardwired to 5h to indicate support for 6 ports. Note that the number of ports indicated in this field may be more than the number of ports indicated in the PI (ABAR + 0Ch) register.



### 12.4.1.2 GHC—Global ICH8 Control Register (D31:F2)

Address Offset: ABAR + 04h–07h      Attribute: R/W  
 Default Value: 00000000h      Size: 32 bits

Bit	Description
31	<p><b>AHCI Enable (AE)</b> — R/W. When set, indicates that an AHCI driver is loaded and the controller will be talked to via AHCI mechanisms. This can be used by an ICH8 that supports both legacy mechanisms (such as SFF-8038i) and AHCI to know when the controller will not be talked to as legacy.</p> <p>0 = Software will only talk to the ICH8 using legacy mechanisms.            1 = Software will only talk to the ICH8 using AHCI. The ICH8 will not have to allow command processing via both AHCI and legacy mechanisms.</p> <p>Software shall set this bit to 1 before accessing other AHCI registers.</p>
30:3	Reserved
2	<p><b>MSI Revert to Single Message (MRSM)</b> — RO: When set to 1 by hardware, indicates that the host controller requested more than one MSI vector but has reverted to using the first vector only. When this bit is cleared to '0', the HBA has not reverted to single MSI mode (i.e. hardware is already in single MSI mode, software has allocated the number of messages requested, or hardware is sharing interrupt vectors if MC.MME &lt; MC.MMC).</p> <p>"MC.MSIE = '1' (MSI is enabled)            "MC.MMC &gt; 0 (multiple messages requested)            "MC.MME &gt; 0 (more than one message allocated)            "MC.MME != MC.MMC (messages allocated not equal to number requested)</p> <p>When this bit is set to '1', single MSI mode operation is in use and software is responsible for clearing bits in the IS register to clear interrupts.</p> <p>This bit shall be cleared to '0' by hardware when any of the four conditions stated is false. This bit is also cleared to '0' when MC.MSIE = '1' and MC.MME = 0h. In this case, the hardware has been programmed to use single MSI mode, and is not "reverting" to that mode.</p> <p>For ICH8, the HBA shall always revert to single MSI mode when the number of vectors allocated by the host is less than the number requested.</p>
1	<p><b>Interrupt Enable (IE)</b> — R/W. This global bit enables interrupts from the ICH8.</p> <p>0 = All interrupt sources from all ports are disabled.            1 = Interrupts are allowed from the AHCI controller.</p>
0	<p><b>HBA Reset (HR)</b> — R/W. Resets ICH8 AHCI controller.</p> <p>0 = No effect            1 = When set by SW, this bit causes an internal reset of the ICH8 AHCI controller. All state machines that relate to data transfers and queuing return to an idle condition, and all ports are re-initialized via COMRESET.</p> <p><b>NOTE:</b> For further details, consult section 12.3.3 of the <i>Serial ATA Advanced Host Controller Interface</i> specification.</p>



### 12.4.1.3 IS—Interrupt Status Register (D31:F2)

Address Offset: ABAR + 08h–0Bh                      Attribute:                      R/WC, RO  
 Default Value: 00000000h                      Size:                      32 bits

This register indicates which of the ports within the controller have an interrupt pending and require service.

Bit	Description
31:7	Reserved. Returns 0.
6 (Mobile Only)	Reserved. Returns 0.
6 (Desktop Only)	<b>Interrupt Pending Status Port[6] (IPS[6])</b> — R/WC. 0 = No interrupt pending. 1 = A command completion coalescing interrupt has been generated.
5 (Mobile Only)	Reserved. Returns 0.
5 (Desktop Only)	<b>Interrupt Pending Status Port[5] (IPS[5])</b> — R/WC. 0 = No interrupt pending. 1 = Port 5 has an interrupt pending. Software can use this information to determine which ports require service after an interrupt.
4 (Mobile Only)	Reserved. Returns 0.
4 (Desktop Only)	<b>Interrupt Pending Status Port[4] (IPS[4])</b> — R/WC. 0 = No interrupt pending. 1 = Port 4 has an interrupt pending. Software can use this information to determine which ports require service after an interrupt.
3 (Mobile Only)	Reserved. Returns 0.
3 (Desktop Only)	<b>Interrupt Pending Status Port[3] (IPS[3])</b> — R/WC. 0 = No interrupt pending. 1 = Port 3 has an interrupt pending. Software can use this information to determine which ports require service after an interrupt.
2	<b>Interrupt Pending Status Port[2] (IPS[2])</b> — R/WC 0 = No interrupt pending. 1 = Port 2 has an interrupt pending. Software can use this information to determine which ports require service after an interrupt.
1	<b>Interrupt Pending Status Port[1] (IPS[1])</b> — R/WC. 0 = No interrupt pending. 1 = Port 1 has an interrupt pending. Software can use this information to determine which ports require service after an interrupt.
0	<b>Interrupt Pending Status Port[0] (IPS[0])</b> — R/WC. 0 = No interrupt pending. 1 = Port 0 has an interrupt pending. Software can use this information to determine which ports require service after an interrupt.



#### 12.4.1.4 PI—Ports Implemented Register (D31:F2)

Address Offset: ABAR + 0Ch–0Fh      Attribute: R/WO, RO  
 Default Value: 00000000h      Size: 32 bits

This register indicates which ports are exposed to the ICH8. It is loaded by platform BIOS. It indicates which ports that the device supports are available for software to use. For ports that are not available, software must not read or write to registers within that port.

Bit	Description
31:6	Reserved. Returns 0.
5 (Desktop Only)	<b>Ports Implemented Port 5 (PI5) — R/WO.</b> 0 = The port is not implemented. 1 = The port is implemented.
5 (Mobile Only)	Ports Implemented Port 5 (PI5) — RO. 0 = The port is not implemented.
4 (Desktop Only)	<b>Ports Implemented Port 4 (PI4) — R/WO.</b> 0 = The port is not implemented. 1 = The port is implemented.
4 (Mobile Only)	Ports Implemented Port 4 (PI4) — RO. 0 = The port is not implemented.
3 (Desktop Only)	<b>Ports Implemented Port 3 (PI3) — R/WO.</b> 0 = The port is not implemented. 1 = The port is implemented.
3 (Mobile Only)	Ports Implemented Port 3 (PI3) — RO. 0 = The port is not implemented.
2	<b>Ports Implemented Port 2 (PI2) — R/WO.</b> 0 = The port is not implemented. 1 = The port is implemented.
1	<b>Ports Implemented Port 1 (PI1) — R/WO.</b> 0 = The port is not implemented. 1 = The port is implemented.
0	<b>Ports Implemented Port 0 (PI0) — R/WO.</b> 0 = The port is not implemented. 1 = The port is implemented.



### 12.4.1.5 VS—AHCI Version (D31:F2)

Address Offset: ABAR + 10h–13h                      Attribute: RO  
 Default Value: 00010100h                      Size: 32 bits

This register indicates the major and minor version of the AHCI specification. It is BCD encoded. The upper two bytes represent the major version number, and the lower two bytes represent the minor version number. Example: Version 3.12 would be represented as 00030102h. The current version of the specification is 1.10 (00010100h).

Bit	Description
31:16	Major Version Number (MJR) — RO. Indicates the major version is 1
15:0	Minor Version Number (MNR) — RO. Indicates the minor version is 10.

### 12.4.1.6 CCC\_CTL—Command Completion Coalescing Control Register (D31:F2)

Address Offset: ABAR + 14h–17h                      Attribute: R/W, RO  
 Default Value: 00000000h                      Size: 32 bits

This register is used to configure the command coalescing feature. This register is reserved if command coalescing is not supported (CAP\_CCCS = '0').

Bit	Description
31:16	<b>Timeout Value (TV)</b> — R/W. The timeout value is specified in 10 microsecond intervals. hbaCCC_Timer is loaded with this timeout value. hbaCCC_Timer is only decremented when commands are outstanding on the selected ports. The HBA will signal a CCC interrupt when hbaCCC_Timer has decremented to '0'. The hbaCCC_Timer is reset to the timeout value on the assertion of each CCC interrupt. A timeout value of '0' is invalid.
15:8	<b>Command Completions (CC)</b> — R/W. Specifies the number of command completions that are necessary to cause a CCC interrupt. The HBA has an internal command completion counter, hbaCCC_CommandsComplete. hbaCCC_CommandsComplete is incremented by one each time a selected port has a command completion. When hbaCCC_CommandsComplete is equal to the command completions value, a CCC interrupt is signaled. The internal command completion counter is reset to '0' on the assertion of each CCC interrupt.
7:3	<b>Interrupt (INT)</b> — RO. Specifies the interrupt used by the CCC feature. This interrupt must be marked as unused in the AHCI Ports Implemented memory register by the corresponding bit being set to '0'. Thus, the CCC_interrupt corresponds to the interrupt for an unimplemented port on the controller. When a CCC interrupt occurs, the IS[INT] bit shall be asserted to '1' regardless of whether PIRQ interrupt or MSI is used. For desktop INT is always 6. Note that in MSI, CC interrupt may share an interrupt vector with other ports. For example, if the number of message allocated is 4, then CCC interrupt share interrupt vector 3 along with port 3, 4, and 5 but IS[6] shall get set.
2:1	Reserved
0	<b>Enable (EN)</b> — R/W. 0 = The command completion coalescing feature is disabled and no CCC interrupts are generated 1 = The command completion coalescing feature is enabled and CCC interrupts may be generated based on timeout or command completion conditions. Software shall only change the contents of the TV and CC fields when EN is cleared to '0'. On transition of this bit from '0' to '1', any updated values for the TV and CC fields shall take effect.



### 12.4.1.7 CCC\_Ports—Command Completion Coalescing Ports Register (D31:F2)

Address Offset: ABAR + 18h–1Ch      Attribute: R/W  
 Default Value: 00000000h      Size: 32 bits

This register is used to specify the ports that are coalesced as part of the CCC feature when CCC\_CTL.EN = '1'. This register is reserved if command coalescing is not supported (CAP\_CCCS = '0').

Bit	Description
31:0	<p><b>Ports (PRT)</b> — R/W.</p> <p>0 = The port is not part of the command completion coalescing feature.            1 = The corresponding port is part of the command completion coalescing feature.            Bits set to '1' in this register must also have the corresponding bit set to '1' in the Ports Implemented register.</p> <p>Bits set to 1 in this register must also have the corresponding bit set to 1 in the Ports Implemented register. An updated value for this field shall take effect within one timer increment (1 millisecond).</p>

### 12.4.1.8 EM\_LOC—Enclosure Management Location Register (D31:F2)

Address Offset: ABAR + 1Ch–1Fh      Attribute: RO  
 Default Value: 01000002h      Size: 32 bits

This register identifies the location and size of the enclosure management message buffer. This register is reserved if enclosure management is not supported (i.e. CAP.EMS = 0).

Bit	Description
31:16	<p><b>Offset (OFST)</b> — RO. The offset of the message buffer in DWords from the beginning of the ABAR.</p>
15:0	<p><b>Buffer Size (SZ)</b> — RO. Specifies the size of the transmit message buffer area in DWords. The ICH8 SATA controller only supports transmit buffer.            A value of 0 is invalid.</p>



### 12.4.1.9 EM\_CTL—Enclosure Management Control Register (D31:F2)

Address Offset: ABAR + 20h–23h                      Attribute:                      R/W, R/WO, RO  
 Default Value: 07010000h                      Size:                      32 bits

This register is used to control and obtain status for the enclosure management interface. This register includes information on the attributes of the implementation, enclosure management messages supported, the status of the interface, whether any message are pending, and is used to initiate sending messages. This register is reserved if enclosure management is not supported (CAP\_EMS = '0').

Bit	Description
31:27	Reserved
26	<b>Activity LED Hardware Driven (ATTR.ALHD)</b> — R/WO. 1 = The SATA controller drives the activity LED for the LED message type in hardware and does not utilize software for this LED. The host controller does not begin transmitting the hardware based activity signal until after software has written CTL.TM=1 after a reset condition.
25	<b>Transmit Only (ATTR.XMT)</b> — RO. 0 = The SATA controller supports transmitting and receiving messages. 1 = The SATA controller only supports transmitting messages and does not support receiving messages.
24	<b>Single Message Buffer (ATTR.SMB)</b> — RO. 0 = There are separate receive and transmit buffers such that unsolicited messages could be supported. 1 = The SATA controller has one message buffer that is shared for messages to transmit and messages received. Unsolicited receive messages are not supported and it is software's responsibility to manage access to this buffer.
23:20	Reserved
19	<b>SGPIO Enclosure Management Messages (SUPP.SGPIO):</b> — RO. 1 = The SATA controller supports the SGPIO register interface message type.
18	<b>SES-2 Enclosure Management Messages (SUPP.SES2):</b> — RO. 1 = The SATA controller supports the SES-2 message type.
17	<b>SAF-TE Enclosure Management Messages (SUPP.SAFTE):</b> — RO. 1 = The SATA controller supports the SAF-TE message type.
16	<b>LED Message Types (SUPP.LED):</b> — RO. 1 = The SATA controller supports the LED message type.
15:10	Reserved
9	<b>Reset (RST)</b> — R/WO. 0 = A write of '0' to this bit by software will have no effect. 1 = When set by software, The SATA controller shall reset all enclosure management message logic and take all appropriate reset actions to ensure messages can be transmitted / received after the reset. After the SATA controller completes the reset operation, the SATA controller shall set the value to '0'.
8	<b>Transmit Message (CTL.TM)</b> — R/WO. 0 = A write of '0' to this bit by software will have no effect. 1 = When set by software, The SATA controller shall transmit the message contained in the message buffer. When the message is completely sent, the SATA controller shall set the value to 0. Software shall not change the contents of the message buffer while CTL.TM is set to 1.
7:1	Reserved
0	<b>Message Received (STS.MR)</b> — RO. Message Received is not supported in ICH8.





## 12.4.2 Port Registers (D31:F2)

Table 126. Port [3:0] DMA Register Address Map (Sheet 1 of 3)

ABAR + Offset	Mnemonic	Register
100h–103h	POCLB	Port 0 Command List Base Address
104h–107h	POCLBU	Port 0 Command List Base Address Upper 32-Bits
108h–10Bh	POFB	Port 0 FIS Base Address
10Ch–10Fh	POFBU	Port 0 FIS Base Address Upper 32-Bits
110h–113h	POIS	Port 0 Interrupt Status
114h–117h	POIE	Port 0 Interrupt Enable
118h–11Bh	POCMD	Port 0 Command
11Ch–11Fh	—	Reserved
120h–123h	POTFD	Port 0 Task File Data
124h–127h	POSIG	Port 0 Signature
128h–12Bh	POSSTS	Port 0 Serial ATA Status
12Ch–12Fh	POSCTL	Port 0 Serial ATA Control
130h–133h	POSERR	Port 0 Serial ATA Error
134h–137h	POSACT	Port 0 Serial ATA Active
138h–13Bh	POCI	Port 0 Command Issue
13Ch–17Fh	—	Reserved
180h–1FFh (Mobile Only)	—	Reserved Registers are not available and software must not read from or write to registers.
180h–183h	P1CLB	Port 1 Command List Base Address
184h–187h	P1CLBU	Port 1 Command List Base Address Upper 32-Bits
188h–18Bh	P1FB	Port 1 FIS Base Address
18Ch–18Fh	P1FBU	Port 1 FIS Base Address Upper 32-Bits
190h–193h	P1IS	Port 1 Interrupt Status
194h–197h	P1IE	Port 1 Interrupt Enable
198h–19Bh	P1CMD	Port 1 Command
19Ch–19Fh	—	Reserved
1A0h–1A3h	P1TFD	Port 1 Task File Data
1A4h–1A7h	P1SIG	Port 1 Signature
1A8h–1ABh	P1SSTS	Port 1 Serial ATA Status
1ACh–1AFh	P1SCTL	Port 1 Serial ATA Control
1B0h–1B3h	P1SERR	Port 1 Serial ATA Error
1B4h–1B7h	P1SACT	Port 1 Serial ATA Active
1B8h–1BBh	P1CI	Port 1 Command Issue
1BCh–1FFh	—	Reserved
200h–203h	P2CLB	Port 2 Command List Base Address
204h–207h	P2CLBU	Port 2 Command List Base Address Upper 32-Bits
208h–20Bh	P2FB	Port 2 FIS Base Address



Table 126. Port [3:0] DMA Register Address Map (Sheet 2 of 3)

ABAR + Offset	Mnemonic	Register
20Ch–20Fh	P2FBU	Port 2 FIS Base Address Upper 32-Bits
210h–213h	P2IS	Port 2 Interrupt Status
214h–217h	P2IE	Port 2 Interrupt Enable
218h–21Bh	P2CMD	Port 2 Command
21Ch–21Fh	—	Reserved
220h–223h	P2TFD	Port 2 Task File Data
224h–227h	P2SIG	Port 2 Signature
228h–22Bh	P2SSTS	Port 2 Serial ATA Status
22Ch–22Fh	P2SCTL	Port 2 Serial ATA Control
230h–233h	P2SERR	Port 2 Serial ATA Error
234h–237h	P2SACT	Port 2 Serial ATA Active
238h–23Bh	P2CI	Port 2 Command Issue
23Ch–27Fh	—	Reserved
280h–2FFh (Mobile Only)	—	Reserved Registers are not available and software must not read from or write to registers.
280h–283h	P3CLB	Port 3 Command List Base Address
284h–287h	P3CLBU	Port 3 Command List Base Address Upper 32-Bits
288h–28Bh	P3FB	Port 3 FIS Base Address
28Ch–28Fh	P3FBU	Port 3 FIS Base Address Upper 32-Bits
290h–293h	P3IS	Port 3 Interrupt Status
294h–297h	P3IE	Port 3 Interrupt Enable
298h–29Bh	P3CMD	Port 3 Command
29Ch–29Fh	—	Reserved
2A0h–2A3h	P3TFD	Port 3 Task File Data
2A4h–2A7h	P3SIG	Port 3 Signature
2A8h–2ABh	P3SSTS	Port 3 Serial ATA Status
2ACh–2AFh	P3SCTL	Port 3 Serial ATA Control
2B0h–2B3h	P3SERR	Port 3 Serial ATA Error
2B4h–2B7h	P3SACT	Port 3 Serial ATA Active
2B8h–2BBh	P3CI	Port 3 Command Issue
2BCh–2FFh	—	Reserved
300h–303h	P2CLB	Port 2 Command List Base Address
304h–307h	P2CLBU	Port 2 Command List Base Address Upper 32-Bits
308h–30Bh	P2FB	Port 2 FIS Base Address
30Ch–30Fh	P4FBU	Port 4 FIS Base Address Upper 32-Bits
310h–313h	P4IS	Port 4 Interrupt Status
314h–317h	P4IE	Port 4 Interrupt Enable
318h–31Bh	P4CMD	Port 4 Command
31Ch–31Fh	—	Reserved



Table 126. Port [3:0] DMA Register Address Map (Sheet 3 of 3)

ABAR + Offset	Mnemonic	Register
320h–323h	P4TFD	Port 4 Task File Data
324h–327h	P4SIG	Port 4 Signature
328h–32Bh	P4SSTS	Port 4 Serial ATA Status
32Ch–32Fh	P4SCTL	Port 4 Serial ATA Control
330h–333h	P4SERR	Port 4 Serial ATA Error
334h–337h	P4SACT	Port 4 Serial ATA Active
338h–33Bh	P4CI	Port 4 Command Issue
33Ch–37Fh	—	Reserved
380h–3FFh (Mobile Only)	—	Reserved Registers are not available and software must not read from or write to registers.
380h–383h	P5CLB	Port 5 Command List Base Address
384h–387h	P5CLBU	Port 5 Command List Base Address Upper 32-Bits
388h–38Bh	P5FB	Port 5 FIS Base Address
38Ch–38Fh	P5FBU	Port 5 FIS Base Address Upper 32-Bits
390h–393h	P5IS	Port 5 Interrupt Status
394h–397h	P5IE	Port 5 Interrupt Enable
398h–39Bh	P5CMD	Port 5 Command
39Ch–39Fh	—	Reserved
3A0h–3A3h	P5TFD	Port 5 Task File Data
3A4h–3A7h	P5SIG	Port 5 Signature
3A8h–3ABh	P5SSTS	Port 5 Serial ATA Status
3ACh–3AFh	P5SCTL	Port 5 Serial ATA Control
3B0h–3B3h	P5SERR	Port 5 Serial ATA Error
3B4h–3B7h	P5SACT	Port 5 Serial ATA Active
3B8h–3BBh	P5CI	Port 5 Command Issue
3BCh–3FFh	—	Reserved



### 12.4.2.1 PxCLB—Port [5:0] Command List Base Address Register (D31:F2)

Address Offset: Port 0: ABAR + 100h      Attribute:      R/W, RO  
Port 1: ABAR + 180h  
Port 2: ABAR + 200h  
Port 3: ABAR + 280h (Desktop Only)  
Port 4: ABAR + 300h (Desktop Only)  
Port 5: ABAR + 380h (Desktop Only)  
Default Value: Undefined      Size:      32 bits

Bit	Description
31:10	<b>Command List Base Address (CLB)</b> — R/W. Indicates the 32-bit base for the command list for this port. This base is used when fetching commands to execute. The structure pointed to by this address range is 1 KB in length. This address must be 1-KB aligned as indicated by bits 31:10 being read/write. Note that these bits are not reset on a HBA reset.
9:0	Reserved — RO

### 12.4.2.2 PxCLBU—Port [5:0] Command List Base Address Upper 32-Bits Register (D31:F2)

Address Offset: Port 0: ABAR + 104h      Attribute:      R/W  
Port 1: ABAR + 184h  
Port 2: ABAR + 204h  
Port 3: ABAR + 284h (Desktop Only)  
Port 4: ABAR + 304h (Desktop Only)  
Port 5: ABAR + 384h (Desktop Only)  
Default Value: Undefined      Size:      32 bits

Bit	Description
31:0	<b>Command List Base Address Upper (CLBU)</b> — R/W. Indicates the upper 32-bits for the command list base address for this port. This base is used when fetching commands to execute. Note that these bits are not reset on a HBA reset.



### 12.4.2.3 PxFB—Port [5:0] FIS Base Address Register (D31:F2)

Address Offset: Port 0: ABAR + 108h      Attribute:      R/W, RO  
 Port 1: ABAR + 188h  
 Port 2: ABAR + 208h  
 Port 3: ABAR + 284h (Desktop Only)  
 Port 4: ABAR + 304h (Desktop Only)  
 Port 5: ABAR + 384h (Desktop Only)  
 Default Value: Undefined      Size:      32 bits

Bit	Description
31:8	<b>FIS Base Address (FB)</b> — R/W. Indicates the 32-bit base for received FISes. The structure pointed to by this address range is 256 bytes in length. This address must be 256-byte aligned, as indicated by bits 31:3 being read/write. Note that these bits are not reset on a HBA reset.
7:0	Reserved — RO

### 12.4.2.4 PxFBU—Port [5:0] FIS Base Address Upper 32-Bits Register (D31:F2)

Address Offset: Port 0: ABAR + 10Ch      Attribute:      R/W  
 Port 1: ABAR + 18Ch  
 Port 2: ABAR + 20Ch  
 Port 3: ABAR + 28Ch  
 Port 4: ABAR + 30Ch  
 Port 5: ABAR + 38Ch  
 Default Value: Undefined      Size:      32 bits

Bit	Description
31:3	<b>Command List Base Address Upper (CLBU)</b> — R/W. Indicates the upper 32-bits for the received FIS base for this port. Note that these bits are not reset on a HBA reset.
2:0	Reserved



### 12.4.2.5 PxIS—Port [5:0] Interrupt Status Register (D31:F2)

Address Offset: Port 0: ABAR + 110h      Attribute: R/WC, RO  
 Port 1: ABAR + 190h  
 Port 2: ABAR + 210h  
 Port 3: ABAR + 290h (Desktop Only)  
 Port 4: ABAR + 310h (Desktop Only)  
 Port 5: ABAR + 390h (Desktop Only)  
 Default Value: 00000000h      Size: 32 bits

Bit	Description
31	Cold Port Detect Status (CPDS) — RO. Cold presence detect is not supported.
30	<b>Task File Error Status (TFES)</b> — R/WC. This bit is set whenever the status register is updated by the device and the error bit (PxTFD.bit 0) is set.
29	<b>Host Bus Fatal Error Status (HBFS)</b> — R/WC. Indicates that the Intel® ICH8 encountered an error that it cannot recover from due to a bad software pointer. In PCI, such an indication would be a target or master abort.
28	<b>Host Bus Data Error Status (HBDS)</b> — R/WC. Indicates that the ICH8 encountered a data error (uncorrectable ECC / parity) when reading from or writing to system memory.
27	<b>Interface Fatal Error Status (IFS)</b> — R/WC. Indicates that the ICH8 encountered an error on the SATA interface which caused the transfer to stop.
26	<b>Interface Non-fatal Error Status (INFS)</b> — R/WC. Indicates that the ICH8 encountered an error on the SATA interface but was able to continue operation.
25	Reserved
24	<b>Overflow Status (OFS)</b> — R/WC. Indicates that the ICH8 received more bytes from a device than was specified in the PRD table for the command.
23	<b>Incorrect Port Multiplier Status (IPMS)</b> — R/WC. Indicates that the ICH8 received a FIS from a device whose Port Multiplier field did not match what was expected. <b>NOTE:</b> Port Multiplier not supported by ICH8.
22	<b>PhyRdy Change Status (PRCS)</b> — RO. When set to one indicates the internal PhyRdy signal changed state. This bit reflects the state of PxSERR.DIAG.N. Unlike most of the other bits in the register, this bit is RO and is only cleared when PxSERR.DIAG.N is cleared.  Note that the internal PhyRdy signal also transitions when the port interface enters partial or slumber power management states. Partial and slumber must be disabled when Surprise Removal Notification is desired, otherwise the power management state transitions will appear as false insertion and removal events.
21:8	Reserved
7	<b>Device Interlock Status (DIS)</b> — R/WC. When set, indicates that a platform interlock switch has been opened or closed, which may lead to a change in the connection state of the device. This bit is only valid in systems that support an interlock switch (CAP.SIS [ABAR+00:bit 28] set).  For systems that do not support an interlock switch, this bit will always be 0.
6	<b>Port Connect Change Status (PCS)</b> — RO. This bit reflects the state of PxSERR.DIAG.X. (ABAR+130h/1D0h/230h/2D0h, bit 26) Unlike other bits in this register, this bit is only cleared when PxSERR.DIAG.X is cleared.  0 = No change in Current Connect Status. 1 = Change in Current Connect Status.
5	<b>Descriptor Processed (DPS)</b> — R/WC. A PRD with the I bit set has transferred all its data.



Bit	Description
4	<b>Unknown FIS Interrupt (UFS)</b> — RO. When set to '1' indicates that an unknown FIS was received and has been copied into system memory. This bit is cleared to '0' by software clearing the PxSERR.DIAG.F bit to '0'. Note that this bit does not directly reflect the PxSERR.DIAG.F bit. PxSERR.DIAG.F is set immediately when an unknown FIS is detected, whereas this bit is set when the FIS is posted to memory. Software should wait to act on an unknown FIS until this bit is set to '1' or the two bits may become out of sync.
3	<b>Set Device Bits Interrupt (SDBS)</b> — R/WC. A Set Device Bits FIS has been received with the I bit set and has been copied into system memory.
2	<b>DMA Setup FIS Interrupt (DSS)</b> — R/WC. A DMA Setup FIS has been received with the I bit set and has been copied into system memory.
1	<b>PIO Setup FIS Interrupt (PSS)</b> — R/WC. A PIO Setup FIS has been received with the I bit set, it has been copied into system memory, and the data related to that FIS has been transferred.
0	<b>Device to Host Register FIS Interrupt (DHRS)</b> — R/WC. A D2H Register FIS has been received with the I bit set, and has been copied into system memory.

#### 12.4.2.6 PxE—Port [5:0] Interrupt Enable Register (D31:F2)

Address Offset:	Port 0: ABAR + 114h	Attribute:	R/W, RO
	Port 1: ABAR + 194h		
	Port 2: ABAR + 214h		
	Port 3: ABAR + 294h (Desktop Only)		
	Port 4: ABAR + 314h (Desktop Only)		
	Port 5: ABAR + 394h (Desktop Only)		
Default Value:	00000000h	Size:	32 bits

This register enables and disables the reporting of the corresponding interrupt to system software. When a bit is set ('1') and the corresponding interrupt condition is active, then an interrupt is generated. Interrupt sources that are disabled ('0') are still reflected in the status registers.

Bit	Description
31	<b>Cold Presence Detect Enable (CPDE)</b> — RO. Cold Presence Detect is not supported.
30	<b>Task File Error Enable (TFEE)</b> — R/W. When set, and GHC.IE and PxTFD.STS.ERR (due to a reception of the error register from a received FIS) are set, the Intel® ICH8 will generate an interrupt.
29	<b>Host Bus Fatal Error Enable (HBFE)</b> — R/W. When set, and GHC.IE and PxS.HBFS are set, the ICH8 will generate an interrupt.
28	<b>Host Bus Data Error Enable (HBDE)</b> — R/W. When set, and GHC.IE and PxS.HBDS are set, the ICH8 will generate an interrupt.
27	<b>Host Bus Data Error Enable (HBDE)</b> — R/W. When set, GHC.IE is set, and PxIS.HBDS is set, the ICH8 will generate an interrupt.
26	<b>Interface Non-fatal Error Enable (INFE)</b> — R/W. When set, GHC.IE is set, and PxIS.INFS is set, the ICH8 will generate an interrupt.
25	Reserved - Should be written as 0
24	<b>Overflow Error Enable (OFE)</b> — R/W. When set, and GHC.IE and PxS.OFS are set, the ICH8 will generate an interrupt.



Bit	Description
23	<b>Incorrect Port Multiplier Enable (IPME)</b> — R/W. When set, and GHC.IE and PxIS.IPMS are set, the ICH8 will generate an interrupt. <b>NOTE:</b> Should be written as 0. Port Multiplier not supported by ICH8.
22	<b>PhyRdy Change Interrupt Enable (PRCE)</b> — R/W. When set, and GHC.IE is set, and PxIS.PRCS is set, the ICH8 shall generate an interrupt.
21:8	Reserved - Should be written as 0
7	<b>Device Interlock Enable (DIE)</b> — R/W. When set, and PxIS.DIS is set, the ICH8 will generate an interrupt. For systems that do not support an interlock switch, this bit shall be a read-only 0.
6	<b>Port Change Interrupt Enable (PCE)</b> — R/W. When set, and GHC.IE and PxS.PCS are set, the ICH8 will generate an interrupt.
5	<b>Descriptor Processed Interrupt Enable (DPE)</b> — R/W. When set, and GHC.IE and PxS.DPS are set, the ICH8 will generate an interrupt
4	<b>Unknown FIS Interrupt Enable (UFIE)</b> — R/W. When set, and GHC.IE is set and an unknown FIS is received, the ICH8 will generate this interrupt.
3	<b>Set Device Bits FIS Interrupt Enable (SDBE)</b> — R/W. When set, and GHC.IE and PxS.SDBS are set, the ICH8 will generate an interrupt.
2	<b>DMA Setup FIS Interrupt Enable (DSE)</b> — R/W. When set, and GHC.IE and PxS.DSS are set, the ICH8 will generate an interrupt.
1	<b>PIO Setup FIS Interrupt Enable (PSE)</b> — R/W. When set, and GHC.IE and PxS.PSS are set, the ICH8 will generate an interrupt.
0	<b>Device to Host Register FIS Interrupt Enable (DHRE)</b> — R/W. When set, and GHC.IE and PxS.DHRS are set, the ICH8 will generate an interrupt.





### 12.4.2.7 PxCMD—Port [5:0] Command Register (D31:F2)

Address Offset: Port 0: ABAR + 118h      Attribute: R/W, RO, R/WO  
 Port 1: ABAR + 198h  
 Port 2: ABAR + 218h  
 Port 3: ABAR + 298h (Desktop Only)  
 Port 4: ABAR + 318h (Desktop Only)  
 Port 5: ABAR + 398h (Desktop Only)

Default Value: 0000w00wh      Size: 32 bits  
 where w = 00?0b (for?, see bit description)

Bit	Description														
31:28	<p><b>Interface Communication Control (ICC)</b> — R/W. This is a four bit field which can be used to control reset and power states of the interface. Writes to this field will cause actions on the interface, either as primitives or an OOB sequence, and the resulting status of the interface will be reported in the PxSSTS register (Address offset Port 0:ABAR+124h, Port 1: ABAR+1A4h, Port 2: ABAR+224h, Port 3: ABAR+2A4h, Port 4: ABAR+224h, Port 5: ABAR+2A4h).</p> <table border="1"> <thead> <tr> <th>Value</th> <th>Definition</th> </tr> </thead> <tbody> <tr> <td>Fh–7h</td> <td>Reserved</td> </tr> <tr> <td>6h</td> <td>Slumber: This will cause the Intel® ICH8 to request a transition of the interface to the slumber state. The SATA device may reject the request and the interface will remain in its current state</td> </tr> <tr> <td>5h–3h</td> <td>Reserved</td> </tr> <tr> <td>2h</td> <td>Partial: This will cause the ICH8 to request a transition of the interface to the partial state. The SATA device may reject the request and the interface will remain in its current state.</td> </tr> <tr> <td>1h</td> <td>Active: This will cause the ICH8 to request a transition of the interface into the active</td> </tr> <tr> <td>0h</td> <td>No-Op / Idle: When software reads this value, it indicates the ICH8 is not in the process of changing the interface state or sending a device reset, and a new link command may be issued.</td> </tr> </tbody> </table> <p>When system software writes a non-reserved value other than No-Op (0h), the ICH8 will perform the action and update this field back to Idle (0h).            If software writes to this field to change the state to a state the link is already in (e.g. interface is in the active state and a request is made to go to the active state), the ICH8 will take no action and return this field to Idle.  <b>NOTE:</b> When the ALPE bit (bit 26) is set, then this register should not be set to 02h or 06h.</p>	Value	Definition	Fh–7h	Reserved	6h	Slumber: This will cause the Intel® ICH8 to request a transition of the interface to the slumber state. The SATA device may reject the request and the interface will remain in its current state	5h–3h	Reserved	2h	Partial: This will cause the ICH8 to request a transition of the interface to the partial state. The SATA device may reject the request and the interface will remain in its current state.	1h	Active: This will cause the ICH8 to request a transition of the interface into the active	0h	No-Op / Idle: When software reads this value, it indicates the ICH8 is not in the process of changing the interface state or sending a device reset, and a new link command may be issued.
Value	Definition														
Fh–7h	Reserved														
6h	Slumber: This will cause the Intel® ICH8 to request a transition of the interface to the slumber state. The SATA device may reject the request and the interface will remain in its current state														
5h–3h	Reserved														
2h	Partial: This will cause the ICH8 to request a transition of the interface to the partial state. The SATA device may reject the request and the interface will remain in its current state.														
1h	Active: This will cause the ICH8 to request a transition of the interface into the active														
0h	No-Op / Idle: When software reads this value, it indicates the ICH8 is not in the process of changing the interface state or sending a device reset, and a new link command may be issued.														
27	<p><b>Aggressive Slumber / Partial (ASP)</b> — R/W. When set, and the ALPE bit (bit 26) is set, the ICH8 shall aggressively enter the slumber state when it clears the PxCI register and the PxSACT register is cleared. When cleared, and the ALPE bit is set, the ICH8 will aggressively enter the partial state when it clears the PxCI register and the PxSACT register is cleared. If CAP.SALP is cleared to '0', software shall treat this bit as reserved.</p>														
26	<p><b>Aggressive Link Power Management Enable (ALPE)</b> — R/W. When set, the ICH8 will aggressively enter a lower link power state (partial or slumber) based upon the setting of the ASP bit (bit 27).</p>														
25	<p><b>Drive LED on ATAPI Enable (DLAE)</b> — R/W. When set, the ICH8 will drive the LED pin active for ATAPI commands (PxCLB[CHz.A] set) in addition to ATA commands. When cleared, the ICH8 will only drive the LED pin active for ATA commands. See <a href="#">Section 5.16.5</a> for details on the activity LED.</p>														



Bit	Description
24	<b>Device is ATAPI (ATAPI)</b> — R/W. When set, the connected device is an ATAPI device. This bit is used by the ICH8 to control whether or not to generate the desktop LED when commands are active. See <a href="#">Section 5.16.5</a> for details on the activity LED.
23:22	Reserved
21 (ICH8R, ICH8DO, ICH8DH Only)	<b>External SATA Port (ESP)</b> — R/WO. 0 = This port supports internal SATA devices only. 1 = This port will be used with an external SATA device. When set, CAP.SXS must also be set.
21	Reserved
21 (ICH8 Base, and ICH8 Mobile Only)	Reserved
20	Reserved
19	<b>Interlock Switch Attached to Port (ISP)</b> — R/WO. When interlock switches are supported in the platform (CAP.SIS [ABAR+00h:bit 28] set), this indicates whether this particular port has an interlock switch attached. This bit can be used by system software to enable such features as aggressive power management, as disconnects can always be detected regardless of PHY state with an interlock switch. When this bit is set, it is expected that HPCP (bit 18) in this register is also set.  The ICH8 takes no action on the state of this bit – it is for system software only. For example, if this bit is cleared, and an interlock switch toggles, the ICH8 still treats it as a proper interlock switch event. Note that these bits are not reset on a HBA reset.
18	<b>Hot Plug Capable Port (HPCP)</b> — R/WO. 0 = Port is not capable of Hot-Plug. 1 = Port is Hot-Plug capable.  This indicates whether the platform exposes this port to a device which can be Hot-Plugged. SATA by definition is hot-pluggable, but not all platforms are constructed to allow the device to be removed (it may be screwed into the chassis, for example). This bit can be used by system software to indicate a feature such as “eject device” to the end-user. The ICH8 takes no action on the state of this bit - it is for system software only. For example, if this bit is cleared, and a Hot-Plug event occurs, the ICH8 still treats it as a proper Hot-Plug event. Note that these bits are not reset on a HBA reset.
17	<b>Port Multiplier Attached (PMA)</b> — RO / R/W. When this bit is set, a port multiplier is attached to the ICH8 for this port. When cleared, a port multiplier is not attached to this port.  This bit is RO 0 when CAP.PMS (offset ABAR+00h:bit 17) = 0 and R/W when CAP.PMS = 1. <b>NOTE:</b> Port Multiplier not supported by ICH8.
16	Port Multiplier FIS Based Switching Enable (PMFSE) — RO. The ICH8 does not support FIS-based switching. <b>NOTE:</b> Port Multiplier not supported by ICH8.
15	<b>Controller Running (CR)</b> — RO. When this bit is set, the DMA engines for a port are running. See section 5.2.2 of the <i>Serial ATA AHCI Specification</i> for details on when this bit is set and cleared by the ICH8.
14	<b>FIS Receive Running (FR)</b> — RO. When set, the FIS Receive DMA engine for the port is running. See section 12.2.2 of the <i>Serial ATA AHCI Specification</i> for details on when this bit is set and cleared by the ICH8.



Bit	Description
13	<p><b>Interlock Switch State (ISS)</b> — RO. For systems that support interlock switches (via CAP.SIS [ABAR+00h:bit 28]), if an interlock switch exists on this port (via ISP in this register), this bit indicates the current state of the interlock switch. A 0 indicates the switch is closed, and a 1 indicates the switch is opened.</p> <p>For systems that do not support interlock switches, or if an interlock switch is not attached to this port, this bit reports 0.</p>
12:8	<p><b>Current Command Slot (CCS)</b> — RO. Indicates the current command slot the ICH8 is processing. This field is valid when the ST bit is set in this register, and is constantly updated by the ICH8. This field can be updated as soon as the ICH8 recognizes an active command slot, or at some point soon after when it begins processing the command.</p> <p>This field is used by software to determine the current command issue location of the ICH8. In queued mode, software shall not use this field, as its value does not represent the current command being executed. Software shall only use PxCI and PxSACT when running queued commands.</p>
7:5	Reserved
4	<p><b>FIS Receive Enable (FRE)</b> — R/W. When set, the ICH8 may post received FISes into the FIS receive area pointed to by PxFB (ABAR+108h/188h/208h/288h) and PxFBU (ABAR+10Ch/18Ch/20Ch/28Ch). When cleared, received FISes are not accepted by the ICH8, except for the first D2H (device-to-host) register FIS after the initialization sequence.</p> <p>System software must not set this bit until PxFB (PxFBU) have been programmed with a valid pointer to the FIS receive area, and if software wishes to move the base, this bit must first be cleared, and software must wait for the FR bit (bit 14) in this register to be cleared.</p>
3	<p><b>Command List Override (CLO)</b> — R/W. Setting this bit to '1' causes PxTFD.STS.BSY and PxTFD.STS.DRQ to be cleared to '0'. This allows a software reset to be transmitted to the device regardless of whether the BSY and DRQ bits are still set in the PxTFD.STS register. The HBA sets this bit to '0' when PxTFD.STS.BSY and PxTFD.STS.DRQ have been cleared to '0'. A write to this register with a value of '0' shall have no effect.</p> <p>This bit shall only be set to '1' immediately prior to setting the PxCMD.ST bit to 1 from a previous value of 0. Setting this bit to 1 at any other time is not supported and will result in indeterminate behavior. Software must wait for CLO to be cleared to 0 before setting PxCMD.ST to 1.</p>
2	Power On Device (POD) — RO. Cold presence detect not supported. Defaults to 1.
1	<p><b>Spin-Up Device (SUD)</b> — R/W / RO</p> <p>This bit is R/W and defaults to 0 for systems that support staggered spin-up (R/W when CAP.SSS (ABAR+00h:bit 27) is 1). Bit is RO 1 for systems that do not support staggered spin-up (when CAP.SSS is 0).</p> <p>0 = No action.</p> <p>1 = On an edge detect from 0 to 1, the ICH8 starts a COMRESET initialization sequence to the device.</p> <p>Clearing this bit to 0 does not cause any OOB signal to be sent on the interface. When this bit is cleared to 0 and PxSCTL.DET=0h, the HBA will enter listen mode.</p>
0	<p><b>Start (ST)</b> — R/W. When set, the ICH8 may process the command list. When cleared, the ICH8 may not process the command list. Whenever this bit is changed from a 0 to a 1, the ICH8 starts processing the command list at entry 0. Whenever this bit is changed from a 1 to a 0, the PxCI register is cleared by the ICH8 upon the ICH8 putting the controller into an idle state.</p> <p>Refer to Section 12.2.1 of the Serial ATA AHCI Specification for important restrictions on when ST can be set to 1.</p>



### 12.4.2.8 PxTFD—Port [5:0] Task File Data Register (D31:F2)

Address Offset: Port 0: ABAR + 120h      Attribute:      RO  
 Port 1: ABAR + 1A0h  
 Port 2: ABAR + 220h  
 Port 3: ABAR + 2A0h (Desktop Only)  
 Port 4: ABAR + 320h (Desktop Only)  
 Port 5: ABAR + 3A0h (Desktop Only)  
 Default Value: 0000007Fh      Size:      32 bits

This is a 32-bit register that copies specific fields of the task file when FISes are received. The FISes that contain this information are:

- D2H Register FIS
- PIO Setup FIS
- Set Device Bits FIS

Bit	Description		
31:16	Reserved		
15:8	<b>Error (ERR)</b> — RO. Contains the latest copy of the task file error register.		
7:0	<b>Status (STS)</b> — RO. Contains the latest copy of the task file status register. Fields of note in this register that affect AHCI.		
	<b>Bit</b> <b>Field</b> <b>Definition</b>		
	7	BSY	Indicates the interface is busy
	6:4	N/A	Not applicable
	3	DRQ	Indicates a data transfer is requested
	2:1	N/A	Not applicable
0	ERR	Indicates an error during the transfer	

### 12.4.2.9 PxSIG—Port [5:0] Signature Register (D31:F2)

Address Offset: Port 0: ABAR + 124h      Attribute:      RO  
 Port 1: ABAR + 1A4h  
 Port 2: ABAR + 224h  
 Port 3: ABAR + 2A4h (Desktop Only)  
 Port 4: ABAR + 324h (Desktop Only)  
 Port 5: ABAR + 3A4h (Desktop Only)  
 Default Value: FFFFFFFFh      Size:      32 bits

This is a 32-bit register which contains the initial signature of an attached device when the first D2H Register FIS is received from that device. It is updated once after a reset sequence.

Bit	Description	
31:0	<b>Signature (SIG)</b> — RO. Contains the signature received from a device on the first D2H register FIS. The bit order is as follows:	
	<b>Bit</b> <b>Field</b>	
	31:24	LBA High Register
	23:16	LBA Mid Register
	15:8	LBA Low Register
7:0	Sector Count Register	



### 12.4.2.10 PxSSTS—Port [5:0] Serial ATA Status Register (D31:F2)

Address Offset:	Port 0: ABAR + 128h	Attribute:	RO
	Port 1: ABAR + 1A8h		
	Port 2: ABAR + 228h		
	Port 3: ABAR + 2A8h (Desktop Only)		
	Port 4: ABAR + 328h (Desktop Only)		
	Port 5: ABAR + 3A8h (Desktop Only)		
Default Value:	00000000h	Size:	32 bits

This is a 32-bit register that conveys the current state of the interface and host. The ICH8 updates it continuously and asynchronously. When the ICH8 transmits a COMRESET to the device, this register is updated to its reset values.

Bit	Description										
31:12	Reserved										
11:8	<p><b>Interface Power Management (IPM)</b> — RO. Indicates the current interface state:</p> <table> <thead> <tr> <th>Value</th> <th>Description</th> </tr> </thead> <tbody> <tr> <td>0h</td> <td>Device not present or communication not established</td> </tr> <tr> <td>1h</td> <td>Interface in active state</td> </tr> <tr> <td>2h</td> <td>Interface in PARTIAL power management state</td> </tr> <tr> <td>6h</td> <td>Interface in SLUMBER power management state</td> </tr> </tbody> </table> <p>All other values reserved.</p>	Value	Description	0h	Device not present or communication not established	1h	Interface in active state	2h	Interface in PARTIAL power management state	6h	Interface in SLUMBER power management state
Value	Description										
0h	Device not present or communication not established										
1h	Interface in active state										
2h	Interface in PARTIAL power management state										
6h	Interface in SLUMBER power management state										
7:4	<p><b>Current Interface Speed (SPD)</b> — RO. Indicates the negotiated interface communication speed.</p> <table> <thead> <tr> <th>Value</th> <th>Description</th> </tr> </thead> <tbody> <tr> <td>0h</td> <td>Device not present or communication not established</td> </tr> <tr> <td>1h</td> <td>Generation 1 communication rate negotiated</td> </tr> <tr> <td>2h</td> <td>Generation 2 communication rate negotiated</td> </tr> </tbody> </table> <p>All other values reserved. ICH8 Supports Generation 1 communication rates (1.5 Gb/sec) and Gen 2 rates (3.0 Gb/s).</p>	Value	Description	0h	Device not present or communication not established	1h	Generation 1 communication rate negotiated	2h	Generation 2 communication rate negotiated		
Value	Description										
0h	Device not present or communication not established										
1h	Generation 1 communication rate negotiated										
2h	Generation 2 communication rate negotiated										
3:0	<p><b>Device Detection (DET)</b> — RO. Indicates the interface device detection and Phy state:</p> <table> <thead> <tr> <th>Value</th> <th>Description</th> </tr> </thead> <tbody> <tr> <td>0h</td> <td>No device detected and Phy communication not established</td> </tr> <tr> <td>1h</td> <td>Device presence detected but Phy communication not established</td> </tr> <tr> <td>3h</td> <td>Device presence detected and Phy communication established</td> </tr> <tr> <td>4h</td> <td>Phy in offline mode as a result of the interface being disabled or running in a BIST loopback mode</td> </tr> </tbody> </table> <p>All other values reserved.</p>	Value	Description	0h	No device detected and Phy communication not established	1h	Device presence detected but Phy communication not established	3h	Device presence detected and Phy communication established	4h	Phy in offline mode as a result of the interface being disabled or running in a BIST loopback mode
Value	Description										
0h	No device detected and Phy communication not established										
1h	Device presence detected but Phy communication not established										
3h	Device presence detected and Phy communication established										
4h	Phy in offline mode as a result of the interface being disabled or running in a BIST loopback mode										



### 12.4.2.11 PxSCTL — Port [5:0] Serial ATA Control Register (D31:F2)

Address Offset: Port 0: ABAR + 12Ch      Attribute: R/W, RO  
 Port 1: ABAR + 1ACh  
 Port 2: ABAR + 22Ch  
 Port 3: ABAR + 2ACh (Desktop Only)  
 Port 4: ABAR + 32Ch (Desktop Only)  
 Port 5: ABAR + 3ACh (Desktop Only)  
 Default Value: 00000004h      Size: 32 bits

This is a 32-bit read-write register by which software controls SATA capabilities. Writes to the SControl register result in an action being taken by the ICH8 or the interface. Reads from the register return the last value written to it.

Bit	Description										
31:20	Reserved										
19:16	Port Multiplier Port (PMP) — RO. This field is not used by AHCI <b>NOTE:</b> Port Multiplier not supported by ICH8.										
15:12	Select Power Management (SPM) — RO. This field is not used by AHCI										
11:8	<b>Interface Power Management Transitions Allowed (IPM)</b> — R/W. Indicates which power states the ICH8 is allowed to transition to: <table border="1"> <thead> <tr> <th>Value</th> <th>Description</th> </tr> </thead> <tbody> <tr> <td>0h</td> <td>No interface restrictions</td> </tr> <tr> <td>1h</td> <td>Transitions to the PARTIAL state disabled</td> </tr> <tr> <td>2h</td> <td>Transitions to the SLUMBER state disabled</td> </tr> <tr> <td>3h</td> <td>Transitions to both PARTIAL and SLUMBER states disabled</td> </tr> </tbody> </table> All other values reserved	Value	Description	0h	No interface restrictions	1h	Transitions to the PARTIAL state disabled	2h	Transitions to the SLUMBER state disabled	3h	Transitions to both PARTIAL and SLUMBER states disabled
Value	Description										
0h	No interface restrictions										
1h	Transitions to the PARTIAL state disabled										
2h	Transitions to the SLUMBER state disabled										
3h	Transitions to both PARTIAL and SLUMBER states disabled										
7:4	<b>Speed Allowed (SPD)</b> — R/W. Indicates the highest allowable speed of the interface. This speed is limited by the CAP.ISS (ABAR+00h:bit 23:20) field. <table border="1"> <thead> <tr> <th>Value</th> <th>Description</th> </tr> </thead> <tbody> <tr> <td>0h</td> <td>No speed negotiation restrictions</td> </tr> <tr> <td>1h</td> <td>Limit speed negotiation to Generation 1 communication rate</td> </tr> <tr> <td>2h</td> <td>Limit speed negotiation to Generation 2 communication rate</td> </tr> </tbody> </table> ICH8 Supports Generation 1 communication rates (1.5 Gb/sec) and Gen 2 rates (3.0 Gb/s).	Value	Description	0h	No speed negotiation restrictions	1h	Limit speed negotiation to Generation 1 communication rate	2h	Limit speed negotiation to Generation 2 communication rate		
Value	Description										
0h	No speed negotiation restrictions										
1h	Limit speed negotiation to Generation 1 communication rate										
2h	Limit speed negotiation to Generation 2 communication rate										
3:0	<b>Device Detection Initialization (DET)</b> — R/W. Controls the ICH8's device detection and interface initialization. <table border="1"> <thead> <tr> <th>Value</th> <th>Description</th> </tr> </thead> <tbody> <tr> <td>0h</td> <td>No device detection or initialization action requested</td> </tr> <tr> <td>1h</td> <td>Perform interface communication initialization sequence to establish communication. This is functionally equivalent to a hard reset and results in the interface being reset and communications re-initialized</td> </tr> <tr> <td>4h</td> <td>Disable the Serial ATA interface and put Phy in offline mode</td> </tr> </tbody> </table> All other values reserved. When this field is written to a 1h, the ICH8 initiates COMRESET and starts the initialization process. When the initialization is complete, this field shall remain 1h until set to another value by software. This field may only be changed to 1h or 4h when PxCMD.ST is 0. Changing this field while the ICH8 is running results in undefined behavior. Note: It is permissible to implement any of the Serial ATA defined behaviors for transmission of COMRESET when DET=1h.	Value	Description	0h	No device detection or initialization action requested	1h	Perform interface communication initialization sequence to establish communication. This is functionally equivalent to a hard reset and results in the interface being reset and communications re-initialized	4h	Disable the Serial ATA interface and put Phy in offline mode		
Value	Description										
0h	No device detection or initialization action requested										
1h	Perform interface communication initialization sequence to establish communication. This is functionally equivalent to a hard reset and results in the interface being reset and communications re-initialized										
4h	Disable the Serial ATA interface and put Phy in offline mode										



### 12.4.2.12 PxSERR—Port [5:0] Serial ATA Error Register (D31:F2)

Address Offset: Port 0: ABAR + 130h      Attribute:      R/WC  
 Port 1: ABAR + 1B0h  
 Port 2: ABAR + 230h  
 Port 3: ABAR + 2B0h (Desktop Only)  
 Port 4: ABAR + 330h (Desktop Only)  
 Port 5: ABAR + 3B0h (Desktop Only)  
 Default Value: 00000000h      Size:      32 bits

Bit	Description
	<b>Diagnostics (DIAG)</b> — R/WC. This field contains diagnostic error information for use by diagnostic software in validating correct operation or isolating failure modes:
	<b>Bits      Description</b>
31:27	Reserved
26	<b>Exchanged (X)</b> : When set to one this bit indicates a COMINIT signal was received. This bit is reflected in the interrupt register PxIS.PCS.
25	<b>Unrecognized FIS Type (F)</b> : Indicates that one or more FISs were received by the Transport layer with good CRC, but had a type field that was not recognized.
24	<b>Transport state transition error (T)</b> : Indicates that an error has occurred in the transition from one state to another within the Transport layer since the last time this bit was cleared.
23	<b>Link Sequence Error (S)</b> : Indicates that one or more Link state machine error conditions was encountered. The Link Layer state machine defines the conditions under which the link layer detects an erroneous transition.
22	<b>Handshake Error (H)</b> : Indicates that one or more R_ERR handshake response was received in response to frame transmission. Such errors may be the result of a CRC error detected by the recipient, a disparity or 8b/10b decoding error, or other error condition leading to a negative handshake on a transmitted frame.
21	<b>CRC Error (C)</b> : Indicates that one or more CRC errors occurred with the Link Layer.
20	<b>Disparity Error (D)</b> : This field is not used by AHCI.
19	<b>10b to 8b Decode Error (B)</b> : Indicates that one or more 10b to 8b decoding errors occurred.
18	<b>Comm Wake (W)</b> : Indicates that a Comm Wake signal was detected by the Phy.
17	<b>Phy Internal Error (I)</b> : Indicates that the Phy detected some internal error.
16	<b>PhyRdy Change (N)</b> : When set to 1 this bit indicates that the internal PhyRdy signal changed state since the last time this bit was cleared. In the ICH8, this bit will be set when PhyRdy changes from a 0 -> 1 or a 1 -> 0. The state of this bit is then reflected in the PxIS.PRCs interrupt status bit and an interrupt will be generated if enabled. Software clears this bit by writing a 1 to it.



Bit	Description
15:0	<p><b>Error (ERR)</b> — R/WC. The ERR field contains error information for use by host software in determining the appropriate response to the error condition. If one or more of bits 11:8 of this register are set, the controller will stop the current transfer.</p>
	<p><b>Bits Description</b></p>
	<p>15:12 Reserved</p>
	<p>11 <b>Internal Error (E)</b>: The SATA controller failed due to a master or target abort when attempting to access system memory.</p>
	<p>10 <b>Protocol Error (P)</b>: A violation of the Serial ATA protocol was detected. Note: The ICH8 does not set this bit for all protocol violations that may occur on the SATA link.</p>
	<p>9 <b>Persistent Communication or Data Integrity Error (C)</b>: A communication error that was not recovered occurred that is expected to be persistent. Persistent communications errors may arise from faulty interconnect with the device, from a device that has been removed or has failed, or a number of other causes.</p>
	<p>8 <b>Transient Data Integrity Error (T)</b>: A data integrity error occurred that was not recovered by the interface.</p>
	<p>7:2 Reserved</p>
	<p>1 <b>Recovered Communications Error (M)</b>: Communications between the device and host was temporarily lost but was re-established. This can arise from a device temporarily being removed, from a temporary loss of Phy synchronization, or from other causes and may be derived from the PhyNRdy signal between the Phy and Link layers.</p>
	<p>0 <b>Recovered Data Integrity Error (I)</b>: A data integrity error occurred that was recovered by the interface through a retry operation or other recovery action.</p>





### 12.4.2.13 PxSACT—Port [5:0] Serial ATA Active (D31:F2)

Address Offset: Port 0: ABAR + 134h      Attribute:      R/W  
 Port 1: ABAR + 1B4h  
 Port 2: ABAR + 234h  
 Port 3: ABAR + 2B4h (Desktop Only)  
 Port 4: ABAR + 334h (Desktop Only)  
 Port 5: ABAR + 3B4h (Desktop Only)  
 Default Value: 00000000h      Size:      32 bits

Bit	Description
31:0	<p><b>Device Status (DS)</b> — R/W. System software sets this bit for SATA queuing operations prior to setting the PxCI.CI bit in the same command slot entry. This field is cleared via the Set Device Bits FIS.</p> <p>This field is also cleared when PxCMD.ST (ABAR+118h/198h/218h/298h:bit 0) is cleared by software, and as a result of a COMRESET or SRST.</p>

### 12.4.2.14 PxCI—Port [5:0] Command Issue Register (D31:F2)

Address Offset: Port 0: ABAR + 138h      Attribute:      R/W  
 Port 1: ABAR + 1B8h  
 Port 2: ABAR + 238h  
 Port 3: ABAR + 2B8h (Desktop Only)  
 Port 4: ABAR + 338h (Desktop Only)  
 Port 5: ABAR + 3B8h (Desktop Only)  
 Default Value: 00000000h      Size:      32 bits

Bit	Description
31:0	<p><b>Commands Issued (CI)</b> — R/W. This field is set by software to indicate to the ICH8 that a command has been built-in system memory for a command slot and may be sent to the device. When the ICH8 receives a FIS which clears the BSY and DRQ bits for the command, it clears the corresponding bit in this register for that command slot. Bits in this field shall only be set to 1 by software when PxCMD.ST is set to 1.</p> <p>This field is also cleared when PxCMD.ST (ABAR+118h/198h/218h/298h:bit 0) is cleared by software.</p>

§ §





# 13 SATA Controller Registers (D31:F5)

## 13.1 PCI Configuration Registers (SATA–D31:F5)

**Note:** Address locations that are not shown should be treated as Reserved.

All of the SATA registers are in the core well. None of the registers can be locked.

**Table 127. SATA Controller PCI Register Address Map (SATA–D31:F5) (Sheet 1 of 2)**

Offset	Mnemonic	Register Name	Default	Type
00h–01h	VID	Vendor Identification	8086h	RO
02h–03h	DID	Device Identification	See register description	RO
04h–05h	PCICMD	PCI Command	0000h	R/W, RO
06h–07h	PCISTS	PCI Status	02B0h	R/WC, RO
08h	RID	Revision Identification	See register description	RO
09h	PI	Programming Interface	See register description	See register description
0Ah	SCC	Sub Class Code	See register description	See register description
0Bh	BCC	Base Class Code	01h	RO
0Dh	PMLT	Primary Master Latency Timer	00h	RO
10h–13h	PCMD_BAR	Primary Command Block Base Address	00000001h	R/W, RO
14h–17h	PCNL_BAR	Primary Control Block Base Address	00000001h	R/W, RO
18h–1Bh	SCMD_BAR	Secondary Command Block Base Address	00000001h	R/W, RO
1Ch–1Fh	SCNL_BAR	Secondary Control Block Base Address	00000001h	R/W, RO
20h–23h	BAR	Legacy Bus Master Base Address	00000001h	R/W, RO
24h–27h	SIDPBA	Serial ATA Index / Data Pair Base Address	00000000h	See register description
2Ch–2Dh	SVID	Subsystem Vendor Identification	0000h	R/WO
2Eh–2Fh	SID	Subsystem Identification	0000h	R/WO
34h	CAP	Capabilities Pointer	80h	RO
3Ch	INT_LN	Interrupt Line	00h	R/W
3Dh	INT_PN	Interrupt Pin	See register description	RO
40h–41h	IDE_TIMP	Primary IDE Timing	0000h	R/W
42h–43h	IDE_TIMS	Secondary IDE Timing	0000h	R/W
44h	SIDETIM	Slave IDE Timing	00h	R/W
48h	SDMA_CNT	Synchronous DMA Control	00h	R/W



Table 127. SATA Controller PCI Register Address Map (SATA–D31:F5) (Sheet 2 of 2)

Offset	Mnemonic	Register Name	Default	Type
4Ah–4Bh	SDMA_TIM	Synchronous DMA Timing	0000h	R/W
54h–57h	IDE_CONFIG	IDE I/O Configuration	00000000h	R/W
70h–71h	PID	PCI Power Management Capability ID	See register description	RO
72h–73h	PC	PCI Power Management Capabilities	4002h	RO
74h–75h	PMCS	PCI Power Management Control and Status	0000h	R/W, RO, R/WC
80h–81h	MSICI	Message Signaled Interrupt Capability ID	7005h	RO
82h–83h	MSIMC	Message Signaled Interrupt Message Control	0000h	RO, R/W
84h–87h	MSIMA	Message Signaled Interrupt Message Address	00000000h	RO, R/W
88h–89h	MSIMD	Message Signaled Interrupt Message Data	0000h	R/W
90h	MAP	Address Map	00h	R/W
92h–93h	PCS	Port Control and Status	0000h	R/W, RO, R/WC
94h–97h	SIR	SATA Initialization Register	00000000h	R/W
A0h	SIRI	SATA Indexed Registers Index	00h	R/W
A4h	STRD	SATA Indexed Register Data	XXXXXXXXh	R/W
A8h–ABh	SCAP0	SATA Capability Register 0	00100012h	RO
ACh–AFh	SCAP1	SATA Capability Register 1	00000048h	RO
C0h	ATC	APM Trapping Control	00h	R/W
C4h	ATS	ATM Trapping Status	00h	R/WC
D0h–D3h	SP	Scratch Pad	00000000h	R/W
E0h–E3h	BFCS	BIST FIS Control/Status	00000000h	R/W, R/WC
E4h–E7h	BFTD1	BIST FIS Transmit Data, DW1	00000000h	R/W
E8h–EBh	BFTD2	BIST FIS Transmit Data, DW2	00000000h	R/W

**NOTE:** The ICH8 SATA controller is not arbitrated as a PCI device, therefore it does not need a master latency timer.

### 13.1.1 VID—Vendor Identification Register (SATA–D31:F5)

Offset Address: 00h–01h                      Attribute: RO  
 Default Value: 8086h                        Size: 16 bit  
 Lockable: No                                    Power Well: Core

Bit	Description
15:0	Vendor ID — RO. This is a 16-bit value assigned to Intel. Intel VID = 8086h



### 13.1.2 DID—Device Identification Register (SATA—D31:F5)

Offset Address: 02h–03h                      Attribute: RO  
 Default Value: See bit description        Size: 16 bit  
 Lockable: No                                    Power Well: Core

Bit	Description
15:0	Device ID — RO. This is a 16-bit value assigned to the Intel® ICH8 SATA controller. <b>NOTE:</b> The value of this field will change dependent upon the value of the MAP Register. See the Intel ICH8 Family Specification Update.

### 13.1.3 PCICMD—PCI Command Register (SATA—D31:F5)

Address Offset: 04h–05h                      Attribute: RO, R/W  
 Default Value: 0000h                        Size: 16 bits

Bit	Description
15:11	Reserved
10	<b>Interrupt Disable</b> — R/W. This disables pin-based INTx# interrupts. This bit has no effect on MSI operation. 0 = Internal INTx# messages are generated if there is an interrupt and MSI is not enabled. 1 = Internal INTx# messages will not be generated.
9	Fast Back to Back Enable (FBE) — RO. Reserved as 0.
8	SERR# Enable ( <b>SERR_EN</b> ) — RO. Reserved as 0.
7	Wait Cycle Control (WCC) — RO. Reserved as 0.
6	<b>Parity Error Response (PER)</b> — R/W. 0 = Disabled. SATA controller will not generate PERR# when a data parity error is detected. 1 = Enabled. SATA controller will generate PERR# when a data parity error is detected.
5	VGA Palette Snoop (VPS) — RO. Reserved as 0.
4	Postable Memory Write Enable (PMWE) — RO. Reserved as 0.
3	Special Cycle Enable (SCE) — RO. Reserved as 0.
2	<b>Bus Master Enable (BME)</b> — R/W. This bit controls the ICH8's ability to act as a PCI master for IDE Bus Master transfers. This bit does not impact the generation of completions for split transaction commands.
1	<b>Memory Space Enable (MSE)</b> — RO. This controller does not support AHCI, therefore no memory space is required.
0	<b>I/O Space Enable (IOSE)</b> — R/W. This bit controls access to the I/O space registers. 0 = Disables access to the Legacy or Native IDE ports (both Primary and Secondary) as well as the Bus Master I/O registers. 1 = Enable. Note that the Base Address register for the Bus Master registers should be programmed before this bit is set.



### 13.1.4 PCISTS — PCI Status Register (SATA–D31:F5)

Address Offset: 06h–07h                      Attribute:            R/WC, RO  
 Default Value: 02B0h                      Size:                 16 bits

**Note:** For the writable bits, software must write a 1 to clear bits that are set. Writing a 0 to the bit has no effect.

Bit	Description
15	<b>Detected Parity Error (DPE)</b> — R/WC. 0 = No parity error detected by SATA controller. 1 = SATA controller detects a parity error on its interface.
14	<b>Signaled System Error (SSE)</b> — RO. Reserved as 0.
13	<b>Received Master Abort (RMA)</b> — R/WC. 0 = Master abort Not generated. 1 = SATA controller, as a master, generated a master abort.
12	Reserved as 0 — RO.
11	<b>Signaled Target Abort (STA)</b> — RO. Reserved as 0.
10:9	DEVSEL# Timing Status (DEV_STS) — RO. 01 = Hardwired; Controls the device select time for the SATA controller's PCI interface.
8	<b>Data Parity Error Detected (DPED)</b> — RO. For ICH8, this bit can only be set on read completions received from SIBUS where there is a parity error. 1 = SATA controller, as a master, either detects a parity error or sees the parity error line asserted, and the parity error response bit (bit 6 of the command register) is set.
7	<b>Fast Back to Back Capable (FB2BC)</b> — RO. Reserved as 1.
6	<b>User Definable Features (UDF)</b> — RO. Reserved as 0.
5	<b>66MHz Capable (66MHZ_CAP)</b> — RO. Reserved as 1.
4	<b>Capabilities List (CAP_LIST)</b> — RO. This bit indicates the presence of a capabilities list. The minimum requirement for the capabilities list must be PCI power management for the SATA controller.
3	<b>Interrupt Status (INTS)</b> — RO. Reflects the state of INTx# messages. 0 = Interrupt is cleared (independent of the state of Interrupt Disable bit in the command register [offset 04h]). 1 = Interrupt is to be asserted
2:0	Reserved

### 13.1.5 RID—Revision Identification Register (SATA–D31:F5)

Offset Address: 08h                      Attribute:            RO  
 Default Value: See bit description            Size:                 8 bits

Bit	Description
7:0	Revision ID — RO. Refer to the <i>Intel® I/O Controller Hub 8 (ICH8) Family Specification Update</i> for the value of the Revision ID Register





### 13.1.10 PCMD\_BAR—Primary Command Block Base Address Register (SATA–D31:F5)

Address Offset: 10h–13h                      Attribute: R/W, RO  
Default Value: 00000001h                      Size: 32 bits

Bit	Description
31:16	Reserved
15:3	<b>Base Address</b> — R/W. This field provides the base address of the I/O space (8 consecutive I/O locations).
2:1	Reserved
0	Resource Type Indicator (RTE) — RO. Hardwired to 1 to indicate a request for I/O space.

**NOTE:** This 8-byte I/O space is used in native mode for the Primary Controller's Command Block.

### 13.1.11 PCNL\_BAR—Primary Control Block Base Address Register (SATA–D31:F5)

Address Offset: 14h–17h                      Attribute: R/W, RO  
Default Value: 00000001h                      Size: 32 bits

Bit	Description
31:16	Reserved
15:2	<b>Base Address</b> — R/W. This field provides the base address of the I/O space (4 consecutive I/O locations).
1	Reserved
0	Resource Type Indicator (RTE) — RO. Hardwired to 1 to indicate a request for I/O space.

**NOTE:** This 4-byte I/O space is used in native mode for the Primary Controller's Command Block.

### 13.1.12 SCMD\_BAR—Secondary Command Block Base Address Register (IDE D31:F1)

Address Offset: 18h–1Bh                      Attribute: R/W, RO  
Default Value: 00000001h                      Size: 32 bits

Bit	Description
31:16	Reserved
15:3	<b>Base Address</b> — R/W. This field provides the base address of the I/O space (8 consecutive I/O locations).
2:1	Reserved
0	Resource Type Indicator (RTE) — RO. Hardwired to 1 to indicate a request for I/O space.

**NOTE:** This 8-byte I/O space is used in native mode for the Secondary Controller's Command Block.





### 13.1.13 SCNL\_BAR—Secondary Control Block Base Address Register (IDE D31:F1)

Address Offset: 1Ch–1Fh                      Attribute:                      R/W, RO  
 Default Value: 0000001h                      Size:                              32 bits

Bit	Description
31:16	Reserved
15:2	<b>Base Address</b> — R/W. This field provides the base address of the I/O space (4 consecutive I/O locations).
1	Reserved
0	Resource Type Indicator (RTE) — RO. Hardwired to 1 to indicate a request for I/O space.

**NOTE:** This 4-byte I/O space is used in native mode for the Secondary Controller's Command Block.

### 13.1.14 BAR — Legacy Bus Master Base Address Register (SATA–D31:F5)

Address Offset: 20h–23h                      Attribute:                      R/W, RO  
 Default Value: 0000001h                      Size:                              32 bits

The Bus Master IDE interface function uses Base Address register 5 to request a 16-byte I/O space to provide a software interface to the Bus Master functions. Only 12 bytes are actually used (6 bytes for primary, 6 bytes for secondary). Only bits [15:4] are used to decode the address.

Bit	Description
31:16	Reserved
15:4	<b>Base Address</b> — R/W. This field provides the base address of the I/O space (16 consecutive I/O locations).
3:1	Reserved
0	Resource Type Indicator (RTE) — RO. Hardwired to 1 to indicate a request for I/O space.



### 13.1.15 SIDPBA — SATA Index/Data Pair Base Address Register (SATA–D31:F5)

Address Offset: 24h–27h                      Attribute: R/W, RO  
 Default Value: 00000001h                  Size: 32 bits

This register is an I/O BAR allocating 16 bytes of I/O space for the I/O-mapped registers defined in Section 13.3. Note that although 16 bytes of locations are allocated, some locations are reserved.

Bit	Description
31:16	Reserved
15:4	<b>Base Address (BA)</b> — R/W. Base address of register I/O space
3:1	Reserved
0	Resource Type Indicator (RTE) — RO. Hardwired to 1 to indicate a request for I/O space.

### 13.1.16 SVID—Subsystem Vendor Identification Register (SATA–D31:F5)

Address Offset: 2Ch–2Dh                      Attribute: R/WO  
 Default Value: 0000h                      Size: 16 bits  
 Lockable: No                                  Power Well: Core

Bit	Description
15:0	<b>Subsystem Vendor ID (SVID)</b> — R/WO. Value is written by BIOS. No hardware action taken on this value.

### 13.1.17 SID—Subsystem Identification Register (SATA–D31:F5)

Address Offset: 2Eh–2Fh                      Attribute: R/WO  
 Default Value: 0000h                      Size: 16 bits  
 Lockable: No                                  Power Well: Core

Bit	Description
15:0	<b>Subsystem ID (SID)</b> — R/WO. Value is written by BIOS. No hardware action taken on this value.

### 13.1.18 CAP—Capabilities Pointer Register (SATA–D31:F5)

Address Offset: 34h                              Attribute: RO  
 Default Value: 80h                              Size: 8 bits

Bit	Description
7:0	Capabilities Pointer (CAP_PTR) — RO. Indicates that the first capability pointer offset is 80h. This value changes to 70h if the MAP.MV register (Dev 31:F2:90h, bits 1:0) in configuration space indicates that the SATA function and PATA functions are combined (values of 10b or 10b) or Sub Class Code (CC.SCC) (Dev 31:F2:0Ah) is configure as IDE mode (value of 01).



### 13.1.19 INT\_LN—Interrupt Line Register (SATA–D31:F5)

Address Offset: 3Ch Attribute: R/W  
 Default Value: 00h Size: 8 bits

Bit	Description
7:0	<b>Interrupt Line</b> — R/W. This field is used to communicate to software the interrupt line that the interrupt pin is connected to.

### 13.1.20 INT\_PN—Interrupt Pin Register (SATA–D31:F5)

Address Offset: 3Dh Attribute: RO  
 Default Value: See Register Description Size: 8 bits

Bit	Description
7:0	<b>Interrupt Pin</b> — RO. This reflects the value of D31IP.SIP1 (Chipset Configuration Registers: Offset 3100h:bits 11:8).

### 13.1.21 IDE\_TIM — IDE Timing Register (SATA–D31:F5)

Address Offset: Primary: 40h–41h Attribute: R/W  
 Secondary: 42h–43h  
 Default Value: 0000h Size: 16 bits

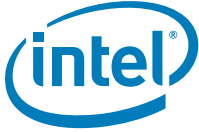
This register controls the timings driven on the IDE cable for PIO and 8237 style DMA transfers. It also controls operation of the buffer for PIO transfers.

**Note:** This register is R/W to maintain software compatibility and enable parallel ATA functionality when the PCI functions are combined. These bits have no effect on SATA operation unless otherwise noted.

Bit	Description
15	<b>IDE Decode Enable (IDE)</b> — R/W. Individually enable/disable the Primary or Secondary decode. 0 = Disable. 1 = Enables the Intel® ICH8 to decode the associated Command Blocks (1F0–1F7h for primary, 170–177h for secondary) and Control Block (3F6h for primary and 376h for secondary). This bit effects the IDE decode ranges for both legacy and native-Mode decoding. <b>NOTE:</b> This bit affects SATA operation in both combined and non-combined ATA modes. See Section 5.16 for more on ATA modes of operation.
14	<b>Drive 1 Timing Register Enable (SITRE)</b> — R/W. 0 = Use bits 13:12, 9:8 for both drive 0 and drive 1. 1 = Use bits 13:12, 9:8 for drive 0, and use the Slave IDE Timing register for drive 1
13:12	<b>IORDY Sample Point (ISP)</b> — R/W. The setting of these bits determines the number of PCI clocks between IDE IOR#/IOW# assertion and the first IORDY sample point. 00 = 5 clocks 01 = 4 clocks 10 = 3 clocks 11 = Reserved



Bit	Description
11:10	Reserved
9:8	<p><b>Recovery Time (RCT)</b> — R/W. The setting of these bits determines the minimum number of PCI clocks between the last IORDY sample point and the IOR#/IOW# strobe of the next cycle.</p> <p>00 = 4 clocks            01 = 3 clocks            10 = 2 clocks            11 = 1 clock</p>
7	<p><b>Drive 1 DMA Timing Enable (DTE1)</b> — R/W.</p> <p>0 = Disable.            1 = Enable the fast timing mode for DMA transfers only for this drive. PIO transfers to the IDE data port will run in compatible timing.</p>
6	<p><b>Drive 1 Prefetch/Posting Enable (PPE1)</b> — R/W.</p> <p>0 = Disable.            1 = Enable Prefetch and posting to the IDE data port for this drive.</p>
5	<p><b>Drive 1 IORDY Sample Point Enable (IE1)</b> — R/W.</p> <p>0 = Disable IORDY sampling for this drive.            1 = Enable IORDY sampling for this drive.</p>
4	<p><b>Drive 1 Fast Timing Bank (TIME1)</b> — R/W.</p> <p>0 = Accesses to the data port will use compatible timings for this drive.            1 = When this bit = 1 and bit 14 = 0, accesses to the data port will use bits 13:12 for the IORDY sample point, and bits 9:8 for the recovery time. When this bit = 1 and bit 14 = 1, accesses to the data port will use the IORDY sample point and recover time specified in the slave IDE timing register.</p>
3	<p><b>Drive 0 DMA Timing Enable (DTE0)</b> — R/W.</p> <p>0 = Disable            1 = Enable fast timing mode for DMA transfers only for this drive. PIO transfers to the IDE data port will run in compatible timing.</p>
2	<p><b>Drive 0 Prefetch/Posting Enable (PPE0)</b> — R/W.</p> <p>0 = Disable prefetch and posting to the IDE data port for this drive.            1 = Enable prefetch and posting to the IDE data port for this drive.</p>
1	<p><b>Drive 0 IORDY Sample Point Enable (IE0)</b> — R/W.</p> <p>0 = Disable IORDY sampling is disabled for this drive.            1 = Enable IORDY sampling for this drive.</p>
0	<p><b>Drive 0 Fast Timing Bank (TIME0)</b> — R/W.</p> <p>0 = Accesses to the data port will use compatible timings for this drive.            1 = Accesses to the data port will use bits 13:12 for the IORDY sample point, and bits 9:8 for the recovery time</p>



### 13.1.22 D1TIM—Device 1 IDE Timing Register (SATA–D31:F5)

Address Offset: 44h    Attribute:            R/W  
Default Value: 00h    Size:                  8 bits

*Note:* This register is R/W to maintain software compatibility and enable parallel ATA functionality when the PCI functions are combined. Device 1 is not allowed on this controller.

Bit	Description
7:0	Reserved

### 13.1.23 SDMA\_CNT—Synchronous DMA Control Register (SATA–D31:F5)

Address Offset: 48h    Attribute:            R/W  
Default Value: 00h    Size:                  8 bits

*Note:* This register is R/W to maintain software compatibility and enable parallel ATA functionality when the PCI functions are combined. These bits have no effect on SATA operation unless otherwise noted.

Bit	Description
7:3	Reserved
2	<b>Secondary Drive 0 ATAx Enable (SDAE0)</b> — R/W. 0 = Disable (default) 1 = Enable DMA timing modes for the secondary master device.
1	Reserved
0	<b>Primary Drive ATAx Enable (PDAE0)</b> — R/W. 0 = Disable (default) 1 = Enable DMA timing modes for the primary master device



### 13.1.24 SDMA\_TIM—Synchronous DMA Timing Register (SATA–D31:F5)

Address Offset: 4Ah–4Bh  
Default Value: 0000h

Attribute: R/W  
Size: 16 bits

**Note:** This register is R/W to maintain software compatibility and enable parallel ATA functionality when the PCI functions are combined. These bits have no effect on SATA operation, unless otherwise noted.

Bit	Description															
15:10	Reserved															
9:8	<p><b>Secondary Drive 0 Cycle Time (SCTO)</b> — R/W. For Ultra ATA mode. The setting of these bits determines the minimum write strobe cycle time (CT). The DMARDY#-to-STOP (RP) time is also determined by the setting of these bits.</p> <table border="1"> <thead> <tr> <th>SCB1 = 0 (33 MHz clock)</th> <th>SCB1 = 1 (66 MHz clock)</th> <th>FAST_SCB1 = 1 (133 MHz clock)</th> </tr> </thead> <tbody> <tr> <td>00 = CT 4 clocks, RP 6 clocks</td> <td>00 = Reserved</td> <td>00 = Reserved</td> </tr> <tr> <td>01 = CT 3 clocks, RP 5 clocks</td> <td>01 = CT 3 clocks, RP 8 clocks</td> <td>01 = CT 3 clocks, RP 16 clocks</td> </tr> <tr> <td>10 = CT 2 clocks, RP 4 clocks</td> <td>10 = CT 2 clocks, RP 8 clocks</td> <td>10 = Reserved</td> </tr> <tr> <td>11 = Reserved</td> <td>11 = Reserved</td> <td>11 = Reserved</td> </tr> </tbody> </table>	SCB1 = 0 (33 MHz clock)	SCB1 = 1 (66 MHz clock)	FAST_SCB1 = 1 (133 MHz clock)	00 = CT 4 clocks, RP 6 clocks	00 = Reserved	00 = Reserved	01 = CT 3 clocks, RP 5 clocks	01 = CT 3 clocks, RP 8 clocks	01 = CT 3 clocks, RP 16 clocks	10 = CT 2 clocks, RP 4 clocks	10 = CT 2 clocks, RP 8 clocks	10 = Reserved	11 = Reserved	11 = Reserved	11 = Reserved
SCB1 = 0 (33 MHz clock)	SCB1 = 1 (66 MHz clock)	FAST_SCB1 = 1 (133 MHz clock)														
00 = CT 4 clocks, RP 6 clocks	00 = Reserved	00 = Reserved														
01 = CT 3 clocks, RP 5 clocks	01 = CT 3 clocks, RP 8 clocks	01 = CT 3 clocks, RP 16 clocks														
10 = CT 2 clocks, RP 4 clocks	10 = CT 2 clocks, RP 8 clocks	10 = Reserved														
11 = Reserved	11 = Reserved	11 = Reserved														
7:2	Reserved															
1:0	<p><b>Primary Drive 0 Cycle Time (PCTO)</b> — R/W. For Ultra ATA mode, the setting of these bits determines the minimum write strobe cycle time (CT). The DMARDY#-to-STOP (RP) time is also determined by the setting of these bits.</p> <table border="1"> <thead> <tr> <th>PCB1 = 0 (33 MHz clock)</th> <th>PCB1 = 1 (66 MHz clock)</th> <th>FAST_PCB1 = 1 (133 MHz clock)</th> </tr> </thead> <tbody> <tr> <td>00 = CT 4 clocks, RP 6 clocks</td> <td>00 = Reserved</td> <td>00 = Reserved</td> </tr> <tr> <td>01 = CT 3 clocks, RP 5 clocks</td> <td>01 = CT 3 clocks, RP 8 clocks</td> <td>01 = CT 3 clocks, RP 16 clocks</td> </tr> <tr> <td>10 = CT 2 clocks, RP 4 clocks</td> <td>10 = CT 2 clocks, RP 8 clocks</td> <td>10 = Reserved</td> </tr> <tr> <td>11 = Reserved</td> <td>11 = Reserved</td> <td>11 = Reserved</td> </tr> </tbody> </table>	PCB1 = 0 (33 MHz clock)	PCB1 = 1 (66 MHz clock)	FAST_PCB1 = 1 (133 MHz clock)	00 = CT 4 clocks, RP 6 clocks	00 = Reserved	00 = Reserved	01 = CT 3 clocks, RP 5 clocks	01 = CT 3 clocks, RP 8 clocks	01 = CT 3 clocks, RP 16 clocks	10 = CT 2 clocks, RP 4 clocks	10 = CT 2 clocks, RP 8 clocks	10 = Reserved	11 = Reserved	11 = Reserved	11 = Reserved
PCB1 = 0 (33 MHz clock)	PCB1 = 1 (66 MHz clock)	FAST_PCB1 = 1 (133 MHz clock)														
00 = CT 4 clocks, RP 6 clocks	00 = Reserved	00 = Reserved														
01 = CT 3 clocks, RP 5 clocks	01 = CT 3 clocks, RP 8 clocks	01 = CT 3 clocks, RP 16 clocks														
10 = CT 2 clocks, RP 4 clocks	10 = CT 2 clocks, RP 8 clocks	10 = Reserved														
11 = Reserved	11 = Reserved	11 = Reserved														

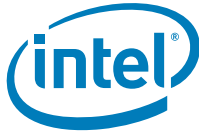


### 13.1.25 IDE\_CONFIG—IDE I/O Configuration Register (SATA—D31:F5)

Address Offset:	54h–57h	Attribute:	R/W
Default Value:	00000000h	Size:	32 bits

**Note:** This register is R/W to maintain software compatibility and enable parallel ATA functionality when the PCI functions are combined. These bits have no effect on SATA operation, unless otherwise noted.

Bit	Description
31:24	Reserved
23:20	Scratchpad (SP2). Intel <sup>®</sup> ICH8 does not perform any actions on these bits.
19:18	<b>SEC_SIG_MODE</b> — R/W. These bits are used to control mode of the Secondary IDE signal pins for swap bay support. If the SRS bit (Chipset Configuration Registers: Offset 3414h: bit 1) is 1, the reset states of bits 19:18 will be 01 (tri-state) instead of 00 (normal). 00 = Normal (Enabled) 01 = Tri-state (Disabled) 10 = Drive low (Disabled) 11 = Reserved
17:16	<b>PRIM_SIG_MODE</b> — R/W. These bits are used to control mode of the Primary IDE signal pins for mobile swap bay support. If the PRS bit (Chipset Configuration Registers: Offset 3414h: bit 1) is 1, the reset states of bits 17:16 will be 01 (tri-state) instead of 00 (normal). 00 = Normal (Enabled) 01 = Tri-state (Disabled) 10 = Drive low (Disabled) 11 = Reserved
15	<b>Fast Secondary Drive 1 Base Clock (FAST_SCB1)</b> — R/W. This bit is used in conjunction with the SCT1 bits (D31:F5:4Ah, bits 13:12) to enable/disable Ultra ATA/100 timings for the Secondary Slave drive. 0 = Disable Ultra ATA/100 timing for the Secondary Slave drive. 1 = Enable Ultra ATA/100 timing for the Secondary Slave drive (overrides bit 3 in this register).
14	<b>Fast Secondary Drive 0 Base Clock (FAST_SCB0)</b> — R/W. This bit is used in conjunction with the SCT0 bits (D31:F5:4Ah, bits 9:8) to enable/disable Ultra ATA/100 timings for the Secondary Master drive. 0 = Disable Ultra ATA/100 timing for the Secondary Master drive. 1 = Enable Ultra ATA/100 timing for the Secondary Master drive (overrides bit 2 in this register).
13	<b>Fast Primary Drive 1 Base Clock (FAST_PCB1)</b> — R/W. This bit is used in conjunction with the PCT1 bits (D31:F5:4Ah, bits 5:4) to enable/disable Ultra ATA/100 timings for the Primary Slave drive. 0 = Disable Ultra ATA/100 timing for the Primary Slave drive. 1 = Enable Ultra ATA/100 timing for the Primary Slave drive (overrides bit 1 in this register).
12	<b>Fast Primary Drive 0 Base Clock (FAST_PCB0)</b> — R/W. This bit is used in conjunction with the PCT0 bits (D31:F5:4Ah, bits 1:0) to enable/disable Ultra ATA/100 timings for the Primary Master drive. 0 = Disable Ultra ATA/100 timing for the Primary Master drive. 1 = Enable Ultra ATA/100 timing for the Primary Master drive (overrides bit 0 in this register).



Bit	Description
11:8	Reserved
7:4	Scratchpad (SP1). ICH8 does not perform any action on these bits.
3	<b>Secondary Drive 1 Base Clock (SCB1)</b> — R/W. 0 = 33 MHz base clock for Ultra ATA timings. 1 = 66 MHz base clock for Ultra ATA timings
2	<b>Secondary Drive 0 Base Clock (SCB0)</b> — R/W. 0 = 33 MHz base clock for Ultra ATA timings. 1 = 66 MHz base clock for Ultra ATA timings
1	<b>Primary Drive 1 Base Clock (PCB1)</b> — R/W. 0 = 33 MHz base clock for Ultra ATA timings. 1 = 66 MHz base clock for Ultra ATA timings
0	<b>Primary Drive 0 Base Clock (PCB0)</b> — R/W. 0 = 33 MHz base clock for Ultra ATA timings. 1 = 66 MHz base clock for Ultra ATA timings

**13.1.26 PID—PCI Power Management Capability Identification Register (SATA—D31:F5)**

Address Offset: 70h–71h                                    Attribute: RO  
 Default Value: 0001h                                    Size: 16 bits

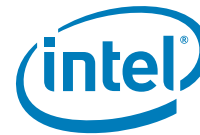
Bits	Description
15:8	Next Capability (NEXT) — RO. 00h — This is the last item in the list.
7:0	Capability ID (CID) — RO. Indicates that this pointer is a PCI power management.

**13.1.27 PC—PCI Power Management Capabilities Register (SATA—D31:F5)**

Address Offset: 72h–73h                                    Attribute: RO  
 Default Value: 4003h                                    Size: 16 bits

Bits	Description
15:11	PME Support (PME_SUP) — RO. Indicates PME# can be generated from the D3 <sub>HOT</sub> state in the SATA host controller.
10	D2 Support (D2_SUP) — RO. Hardwired to 0. The D2 state is not supported
9	D1 Support (D1_SUP) — RO. Hardwired to 0. The D1 state is not supported
8:6	Auxiliary Current (AUX_CUR) — RO. PME# from D3COLD state is not supported, therefore this field is 000b.
5	Device Specific Initialization (DSI) — RO. Hardwired to 0 to indicate that no device-specific initialization is required.
4	Reserved
3	PME Clock (PME_CLK) — RO. Hardwired to 0 to indicate that PCI clock is not required to generate PME#.
2:0	Version (VER) — RO. Hardwired to 011 to indicates support for Revision 1.2 of the PCI Power Management Specification.





**13.1.28 PMCS—PCI Power Management Control and Status Register (SATA–D31:F5)**

Address Offset: 74h–75h Attribute: RO, R/W, R/WC  
 Default Value: 0008h Size: 16 bits

Bits	Description
15	<b>PME Status (PMES)</b> — R/WC. Bit is set when a PME event is to be requested, and if this bit and PMEE is set, a PME# will be generated from the SATA controller
14:9	Reserved
8	<b>PME Enable (PMEE)</b> — R/W. When set, the SATA controller generates PME# form D3 <sub>HOT</sub> on a wake event.
7:4	Reserved
3	<b>No Soft Reset (NSFRST)</b> — RO. These bits are used to indicate whether devices transitioning from D3 <sub>HOT</sub> state to D0 state will perform an internal reset. 0 = Device transitioning from D3 <sub>HOT</sub> state to D0 state perform an internal reset. 1 = Device transitioning from D3 <sub>HOT</sub> state to D0 state do not perform an internal reset. Configuration content is preserved. Upon transition from the D3 <sub>HOT</sub> state to D0 state initialized state, no additional operating system intervention is required to preserve configuration context beyond writing to the PowerState bits. Regardless of this bit, the controller transition from D3 <sub>HOT</sub> state to D0 state by a system or bus segment reset will return to the state D0 uninitialized with only PME context preserved if PME is supported and enabled.
2	Reserved
1:0	<b>Power State (PS)</b> — R/W. These bits are used both to determine the current power state of the SATA controller and to set a new power state. 00 = D0 state 11 = D3 <sub>HOT</sub> state When in the D3 <sub>HOT</sub> state, the controller’s configuration space is available, but the I/O and memory spaces are not. Additionally, interrupts are blocked.

**13.1.29 MAP—Address Map Register (SATA–D31:F5)**

Address Offset: 90h Attribute: RO  
 Default Value: 00h Size: 8 bits

Bits	Description
7:2	Reserved.
1:0	<b>Map Value</b> — RO. Map Value (MV): This field is hardwired to read-only '00' indicating the controller shall support two logical master devices with Port 0 and Port 1 being mapped to Primary Channel and Secondary Channel Respectively



### 13.1.30 PCS—Port Control and Status Register (SATA—D31:F5)

Address Offset: 92h–93h  
Default Value: 0000h

Attribute: R/W, R/WC, RO  
Size: 16 bits

By default, the SATA ports are set to the disabled state (bits [5:0] = '0'). When enabled by software, the ports can transition between the on, partial, and slumber states and can detect devices. When disabled, the port is in the "off" state and cannot detect any devices.

If an AHCI-aware or RAID enabled operating system is being booted then system BIOS shall insure that all supported SATA ports are enabled prior to passing control to the OS. Once the AHCI aware OS is booted it becomes the enabling/disabling policy owner for the individual SATA ports. This is accomplished by manipulating a port's PxSCTL and PxCMD fields. Because an AHCI or RAID aware OS will typically not have knowledge of the PxSCTL bits and because the PxSCTL bits act as master on/off switches for the ports, pre-boot software must insure that these bits are set to '1' prior to booting the OS, regardless as to whether or not a device is currently on the port.

Bits	Description
15:10	Reserved
9	<b>Port 1 Present (P1P)</b> — RO. The status of this bit may change at any time. This bit is cleared when the port is disabled via P1E. This bit is not cleared upon surprise removal of a device. 0 = No device detected. 1 = The presence of a device on Port 1 has been detected.
8	<b>Port 0 Present (POP)</b> — RO. The status of this bit may change at any time. This bit is cleared when the port is disabled via POE. This bit is not cleared upon surprise removal of a device. 0 = No device detected. 1 = The presence of a device on Port 0 has been detected.
7:2	Reserved
1	<b>Port 1 Enabled (P1E)</b> — R/W. 0 = Disabled. The port is in the 'off' state and cannot detect any devices. 1 = Enabled. The port can transition between the on, partial, and slumber states and can detect devices.
0	<b>Port 0 Enabled (POE)</b> — R/W. 0 = Disabled. The port is in the 'off' state and cannot detect any devices. 1 = Enabled. The port can transition between the on, partial, and slumber states and can detect devices.





## 13.2 Bus Master IDE I/O Registers (D31:F5)

The bus master IDE function uses 16 bytes of I/O space, allocated via the BAR register, located in Device 31:Function 2 Configuration space, offset 20h. All bus master IDE I/O space registers can be accessed as byte, word, or dword quantities. Reading reserved bits returns an indeterminate, inconsistent value, and writes to reserved bits have no effect (but should not be attempted). These registers are only used for legacy operation. Software must not use these registers when running AHCI. The description of the I/O registers is shown in [Table 128](#).

**Table 128. Bus Master IDE I/O Register Address Map**

BAR+ Offset	Mnemonic	Register	Default	Type
00	BMICP	Command Register Primary	00h	R/W
01	—	Reserved	—	RO
02	BMISP	Bus Master IDE Status Register Primary	00h	R/W, R/WC, RO
03	—	Reserved	—	RO
04–07	BMIDP	Bus Master IDE Descriptor Table Pointer Primary	xxxxxxxh	R/W
08	BMICS	Command Register Secondary	00h	R/W
09	—	Reserved	—	RO
0Ah	BMISS	Bus Master IDE Status Register Secondary	00h	R/W, R/WC, RO
0Bh	—	Reserved	—	RO
0Ch–0Fh	BMIDS	Bus Master IDE Descriptor Table Pointer Secondary	xxxxxxxh	R/W



### 13.2.1 BMIC[P,S]—Bus Master IDE Command Register (D31:F5)

Address Offset: Primary: BAR + 00h      Attribute: R/W  
 Secondary: BAR + 08h  
 Default Value: 00h      Size: 8 bits

Bit	Description
7:4	Reserved. Returns 0.
3	<p><b>Read / Write Control (R/WC)</b> — R/W. This bit sets the direction of the bus master transfer: This bit must NOT be changed when the bus master function is active.</p> <p>0 = Memory reads            1 = Memory writes</p>
2:1	Reserved. Returns 0.
0	<p><b>Start/Stop Bus Master (START)</b> — R/W.</p> <p>0 = All state information is lost when this bit is cleared. Master mode operation cannot be stopped and then resumed. If this bit is reset while bus master operation is still active (i.e., the Bus Master IDE Active bit (D31:F5:BAR + 02h, bit 0) of the Bus Master IDE Status register for that IDE channel is set) and the drive has not yet finished its data transfer (the Interrupt bit in the Bus Master IDE Status register for that IDE channel is not set), the bus master command is said to be aborted and data transferred from the drive may be discarded instead of being written to system memory.</p> <p>1 = Enables bus master operation of the controller. Bus master operation does not actually start unless the Bus Master Enable bit (D31:F1:04h, bit 2) in PCI configuration space is also set. Bus master operation begins when this bit is detected changing from 0 to 1. The controller will transfer data between the IDE device and memory only when this bit is set. Master operation can be halted by writing a 0 to this bit.</p> <p><b>NOTE:</b> This bit is intended to be cleared by software after the data transfer is completed, as indicated by either the Bus Master IDE Active bit being cleared or the Interrupt bit of the Bus Master IDE Status register for that IDE channel being set, or both. Hardware does not clear this bit automatically. If this bit is cleared to 0 prior to the DMA data transfer being initiated by the drive in a</p>



### 13.2.2 BMIS[P,S]—Bus Master IDE Status Register (D31:F5)

Address Offset: Primary: BAR + 02h      Attribute: R/W, R/WC, RO  
 Secondary: BAR + 0Ah  
 Default Value: 00h      Size: 8 bits

Bit	Description
7	<b>PRD Interrupt Status (PRDIS)</b> — R/WC. 0 = Software clears this bit by writing a 1 to it. 1 = This bit is set when the host controller execution of a PRD that has its PRD_INT bit set.
6	Reserved.
5	<b>Drive 0 DMA Capable</b> — R/W. 0 = Not Capable 1 = Capable. Set by device dependent code (BIOS or device driver) to indicate that drive 0 for this channel is capable of DMA transfers, and that the controller has been initialized for optimum performance. The ICH8 does not use this bit. It is intended for systems that do not attach BMIDE to the PCI bus.
4:3	Reserved. Returns 0.
2	<b>Interrupt</b> — R/WC. 0 = Software clears this bit by writing a 1 to it. 1 = Set when a device FIS is received with the 'I' bit set, provided that software has not disabled interrupts via the IEN bit of the Device Control Register (see chapter 5 of the <i>Serial ATA Specification</i> , Revision 2.5).
1	<b>Error</b> — R/WC. 0 = Software clears this bit by writing a 1 to it. 1 = This bit is set when the controller encounters a target abort or master abort when transferring data on PCI.
0	<b>Bus Master IDE Active (ACT)</b> — RO. 0 = This bit is cleared by the ICH8 when the last transfer for a region is performed, where EOT for that region is set in the region descriptor. It is also cleared by the ICH8 when the Start Bus Master bit (D31:F5:BAR+ 00h, bit 0) is cleared in the Command register. When this bit is read as a 0, all data transferred from the drive during the previous bus master command is visible in system memory, unless the bus master command was aborted. 1 = Set by the ICH8 when the Start bit is written to the Command register.

### 13.2.3 BMID[P,S]—Bus Master IDE Descriptor Table Pointer Register (D31:F5)

Address Offset: Primary: BAR + 04h–07h      Attribute: R/W  
 Secondary: BAR + 0Ch–0Fh  
 Default Value: All bits undefined      Size: 32 bits

Bit	Description
31:2	<b>Address of Descriptor Table (ADDR)</b> — R/W. The bits in this field correspond to bits [31:2] of the memory location of the Physical Region Descriptor (PRD). The Descriptor Table must be DWord-aligned. The Descriptor Table must not cross a 64-KB boundary in memory.
1:0	Reserved



### 13.2.3.1 PxSSTS—Serial ATA Status Register (D31:F5)

Address Offset: BAR + 00h                      Attribute: RO  
 Default Value: 00000000h                      Size: 32 bits

This is a 32-bit register that conveys the current state of the interface and host. The ICH8 updates it continuously and asynchronously. When the ICH8 transmits a COMRESET to the device, this register is updated to its reset values.

Bit	Description										
31:12	Reserved										
11:8	<p><b>Interface Power Management (IPM)</b> — RO. Indicates the current interface state:</p> <table border="1"> <thead> <tr> <th>Value</th> <th>Description</th> </tr> </thead> <tbody> <tr> <td>0h</td> <td>Device not present or communication not established</td> </tr> <tr> <td>1h</td> <td>Interface in active state</td> </tr> <tr> <td>2h</td> <td>Interface in PARTIAL power management state</td> </tr> <tr> <td>6h</td> <td>Interface in SLUMBER power management state</td> </tr> </tbody> </table> <p>All other values reserved.</p>	Value	Description	0h	Device not present or communication not established	1h	Interface in active state	2h	Interface in PARTIAL power management state	6h	Interface in SLUMBER power management state
Value	Description										
0h	Device not present or communication not established										
1h	Interface in active state										
2h	Interface in PARTIAL power management state										
6h	Interface in SLUMBER power management state										
7:4	<p><b>Current Interface Speed (SPD)</b> — RO. Indicates the negotiated interface communication speed.</p> <table border="1"> <thead> <tr> <th>Value</th> <th>Description</th> </tr> </thead> <tbody> <tr> <td>0h</td> <td>Device not present or communication not established</td> </tr> <tr> <td>1h</td> <td>Generation 1 communication rate negotiated</td> </tr> <tr> <td>2h</td> <td>Generation 2 communication rate negotiated</td> </tr> </tbody> </table> <p>All other values reserved.</p> <p>ICH8 Supports Generation 1 communication rates (1.5 Gb/sec) and Gen 2 rates (3.0 Gb/s).</p>	Value	Description	0h	Device not present or communication not established	1h	Generation 1 communication rate negotiated	2h	Generation 2 communication rate negotiated		
Value	Description										
0h	Device not present or communication not established										
1h	Generation 1 communication rate negotiated										
2h	Generation 2 communication rate negotiated										
3:0	<p><b>Device Detection (DET)</b> — RO. Indicates the interface device detection and Phy state:</p> <table border="1"> <thead> <tr> <th>Value</th> <th>Description</th> </tr> </thead> <tbody> <tr> <td>0h</td> <td>No device detected and Phy communication not established</td> </tr> <tr> <td>1h</td> <td>Device presence detected but Phy communication not established</td> </tr> <tr> <td>3h</td> <td>Device presence detected and Phy communication established</td> </tr> <tr> <td>4h</td> <td>Phy in offline mode as a result of the interface being disabled or running in a BIST loopback mode</td> </tr> </tbody> </table> <p>All other values reserved.</p>	Value	Description	0h	No device detected and Phy communication not established	1h	Device presence detected but Phy communication not established	3h	Device presence detected and Phy communication established	4h	Phy in offline mode as a result of the interface being disabled or running in a BIST loopback mode
Value	Description										
0h	No device detected and Phy communication not established										
1h	Device presence detected but Phy communication not established										
3h	Device presence detected and Phy communication established										
4h	Phy in offline mode as a result of the interface being disabled or running in a BIST loopback mode										



### 13.2.3.2 PxSCTL — Serial ATA Control Register (D31:F5)

Address Offset: BAR + 01h                      Attribute: R/W, RO  
 Default Value: 00000004h                      Size: 32 bits

This is a 32-bit read-write register by which software controls SATA capabilities. Writes to the SControl register result in an action being taken by the ICH8 or the interface. Reads from the register return the last value written to it.

Bit	Description										
31:20	Reserved										
19:16	Port Multiplier Port (PMP) — RO. This field is not used by AHCI <b>NOTE:</b> Port Multiplier not supported by ICH8.										
15:12	Select Power Management (SPM) — RO. This field is not used by AHCI										
11:8	<p><b>Interface Power Management Transitions Allowed (IPM)</b> — R/W. Indicates which power states the ICH8 is allowed to transition to:</p> <table border="1"> <thead> <tr> <th>Value</th> <th>Description</th> </tr> </thead> <tbody> <tr> <td>0h</td> <td>No interface restrictions</td> </tr> <tr> <td>1h</td> <td>Transitions to the PARTIAL state disabled</td> </tr> <tr> <td>2h</td> <td>Transitions to the SLUMBER state disabled</td> </tr> <tr> <td>3h</td> <td>Transitions to both PARTIAL and SLUMBER states disabled</td> </tr> </tbody> </table> <p>All other values reserved</p>	Value	Description	0h	No interface restrictions	1h	Transitions to the PARTIAL state disabled	2h	Transitions to the SLUMBER state disabled	3h	Transitions to both PARTIAL and SLUMBER states disabled
Value	Description										
0h	No interface restrictions										
1h	Transitions to the PARTIAL state disabled										
2h	Transitions to the SLUMBER state disabled										
3h	Transitions to both PARTIAL and SLUMBER states disabled										
7:4	<p><b>Speed Allowed (SPD)</b> — R/W. Indicates the highest allowable speed of the interface. This speed is limited by the CAP.ISS (ABAR+00h:bit 23:20) field.</p> <table border="1"> <thead> <tr> <th>Value</th> <th>Description</th> </tr> </thead> <tbody> <tr> <td>0h</td> <td>No speed negotiation restrictions</td> </tr> <tr> <td>1h</td> <td>Limit speed negotiation to Generation 1 communication rate</td> </tr> <tr> <td>2h</td> <td>Limit speed negotiation to Generation 2 communication rate</td> </tr> </tbody> </table> <p>All other values reserved.            ICH8 Supports Generation 1 communication rates (1.5 Gb/sec) and Gen 2 rates (3.0 Gb/s).</p>	Value	Description	0h	No speed negotiation restrictions	1h	Limit speed negotiation to Generation 1 communication rate	2h	Limit speed negotiation to Generation 2 communication rate		
Value	Description										
0h	No speed negotiation restrictions										
1h	Limit speed negotiation to Generation 1 communication rate										
2h	Limit speed negotiation to Generation 2 communication rate										
3:0	<p><b>Device Detection Initialization (DET)</b> — R/W. Controls the ICH8's device detection and interface initialization.</p> <table border="1"> <thead> <tr> <th>Value</th> <th>Description</th> </tr> </thead> <tbody> <tr> <td>0h</td> <td>No device detection or initialization action requested</td> </tr> <tr> <td>1h</td> <td>Perform interface communication initialization sequence to establish communication. This is functionally equivalent to a hard reset and results in the interface being reset and communications re-initialized</td> </tr> <tr> <td>4h</td> <td>Disable the Serial ATA interface and put Phy in offline mode</td> </tr> </tbody> </table> <p>All other values reserved.            When this field is written to a 1h, the ICH8 initiates COMRESET and starts the initialization process. When the initialization is complete, this field shall remain 1h until set to another value by software.            This field may only be changed to 1h or 4h when PxCMD.ST is 0. Changing this field while the ICH8 is running results in undefined behavior.</p>	Value	Description	0h	No device detection or initialization action requested	1h	Perform interface communication initialization sequence to establish communication. This is functionally equivalent to a hard reset and results in the interface being reset and communications re-initialized	4h	Disable the Serial ATA interface and put Phy in offline mode		
Value	Description										
0h	No device detection or initialization action requested										
1h	Perform interface communication initialization sequence to establish communication. This is functionally equivalent to a hard reset and results in the interface being reset and communications re-initialized										
4h	Disable the Serial ATA interface and put Phy in offline mode										





### 13.2.3.3 PxSERR—Serial ATA Error Register (D31:F5)

Address Offset: BAR + 02h  
 Default Value: 00000000h

Attribute: R/WC  
 Size: 32 bits

Bit	Description
	<b>Diagnostics (DIAG)</b> — R/WC. Contains diagnostic error information for use by diagnostic software in validating correct operation or isolating failure modes:
	<b>Bits Description</b>
31:27	Reserved
26	<b>Exchanged (X)</b> : When set to one this bit indicates a COMINIT signal was received. This bit is reflected in the interrupt register PxIS.PCS.
25	<b>Unrecognized FIS Type (F)</b> : Indicates that one or more FISs were received by the Transport layer with good CRC, but had a type field that was not recognized.
24	<b>Transport state transition error (T)</b> : Indicates that an error has occurred in the transition from one state to another within the Transport layer since the last time this bit was cleared.
23	<b>Link Sequence Error (S)</b> : Indicates that one or more Link state machine error conditions was encountered. The Link Layer state machine defines the conditions under which the link layer detects an erroneous transition.
31:16	22 <b>Handshake Error (H)</b> : Indicates that one or more R_ERR handshake response was received in response to frame transmission. Such errors may be the result of a CRC error detected by the recipient, a disparity or 8b/10b decoding error, or other error condition leading to a negative handshake on a transmitted frame.
21	<b>CRC Error (C)</b> : Indicates that one or more CRC errors occurred with the Link Layer.
20	<b>Disparity Error (D)</b> : This field is not used by AHCI.
19	<b>10b to 8b Decode Error (B)</b> : Indicates that one or more 10b to 8b decoding errors occurred.
18	<b>Comm Wake (W)</b> : Indicates that a Comm Wake signal was detected by the Phy.
17	<b>Phy Internal Error (I)</b> : Indicates that the Phy detected some internal error.
16	<b>PhyRdy Change (N)</b> : When set to 1 this bit indicates that the internal PhyRdy signal changed state since the last time this bit was cleared. In the ICH8, this bit will be set when PhyRdy changes from a 0 -> 1 or a 1 -> 0. The state of this bit is then reflected in the PxIS.PPCS interrupt status bit and an interrupt will be generated if enabled. Software clears this bit by writing a 1 to it.



Bit	Description
15:0	<p><b>Error (ERR)</b> — R/WC. The ERR field contains error information for use by host software in determining the appropriate response to the error condition. If one or more of bits 11:8 of this register are set, the controller will stop the current transfer.</p>
	<p><b>Bits</b>    <b>Description</b></p>
	<p>15:12    Reserved</p>
	<p>11        <b>Internal Error (E)</b>: The SATA controller failed due to a master or target abort when attempting to access system memory.</p>
	<p>10        <b>Protocol Error (P)</b>: A violation of the Serial ATA protocol was detected. Note: The ICH8 does not set this bit for all protocol violations that may occur on the SATA link.</p>
	<p>9         <b>Persistent Communication or Data Integrity Error (C)</b>: A communication error that was not recovered occurred that is expected to be persistent. Persistent communications errors may arise from faulty interconnect with the device, from a device that has been removed or has failed, or a number of other causes.</p>
	<p>8         <b>Transient Data Integrity Error (T)</b>: A data integrity error occurred that was not recovered by the interface.</p>
	<p>7:2      Reserved</p>
	<p>1         <b>Recovered Communications Error (M)</b>: Communications between the device and host was temporarily lost but was re-established. This can arise from a device temporarily being removed, from a temporary loss of Phy synchronization, or from other causes and may be derived from the PhyNRdy signal between the Phy and Link layers.</p>
	<p>0         <b>Recovered Data Integrity Error (I)</b>: A data integrity error occurred that was recovered by the interface through a retry operation or other recovery action.</p>



## 13.3 Serial ATA Index/Data Pair Superset Registers

All of these I/O registers are in the core well. They are exposed only when CC.SCC is 01h (i.e. IDE programming interface) and the controller is not in combined mode. These are Index/Data Pair registers that are used to access the SerialATA superset registers (SerialATA Status, SerialATA Control and SerialATA Error). The I/O space for these registers is allocated through SIDPBA. Locations with offset from 08h to 0Fh are reserved for future expansion. Software-write operations to the reserved locations shall have no effect while software-read operations to the reserved locations shall return 0.

### 13.3.1 SINDX—SATA Index Register (D31:F5)

Address Offset: SIDPBA + 00h                      Attribute:                      R/W  
 Default Value: 00000000h                      Size:                              32 bits

**Note:** These are Index/Data Pair Registers that are used to access the SSTS, SCTL, and SERR. The I/O space for these registers is allocated through SIDPBA.

Bit	Description
31:16	Reserved
15:8	<b>Port Index (PIDX)</b> — R/W: This Index field is used to specify the port of the SATA controller at which the port-specific SSTS, SCTL, and SERR registers are located. 00h = Primary Master (Port 0) 02h = Secondary Master (Port 1) All other values are Reserved.
7:0	<b>Register Index (RIDX)</b> — R/W: This Index field is used to specify one out of three registers currently being indexed into. 00h = SSTS 01h = SCTL 02h = SERR All other values are Reserved

### 13.3.2 SDATA—SATA Index Data Register (D31:F5)

Address Offset: SIDPBA + 04h                      Attribute:                      R/W  
 Default Value: All bits undefined                      Size:                              32 bits

**Note:** These are Index/Data Pair Registers that are used to access the SSTS, SCTL, and SERR. The I/O space for these registers is allocated through SIDPBA.

Bit	Description
31:0	<b>Data (DATA)</b> — R/W: This Data register is a “window” through which data is read or written to the memory mapped registers. A read or write to this Data register triggers a corresponding read or write to the memory mapped register pointed to by the Index register. The Index register must be setup prior to the read or write to this Data register. Note that a physical register is not actually implemented as the data is actually stored in the memory mapped registers. Since this is not a physical register, the “default” value is the same as the default value of the register pointed to by Index.



§ §



# 14 UHCI Controllers Registers

## 14.1 PCI Configuration Registers (USB—D29:F0/F1/F2, D26:F0/F1)

**Note:** The USB functions may be hidden based on the value of the corresponding bits in the Function Disable Register (see Chipset Configuration Registers). UHCIs must be disabled from highest number to lowest within their specific PCI device.

**Table 129. UHCI Controller PCI Configuration Map**

UHCI	PCI Device:Function	Notes
UHCI #1	D29:F0	
UHCI #2	D29:F1	
UHCI #3	D29:F2	
UHCI #4	D26:F0	
UHCI #5	D26:F1	

**Note:** Register address locations that are not shown in [Table 130](#) and should be treated as Reserved (see [Section 6.2](#) for details).

**Table 130. UHCI Controller PCI Register Address Map (USB—D29:F0/F1/F2, D26:F0/F1) (Sheet 1 of 2)**

Offset	Mnemonic	Register Name	UHCI #1–5 Default	Type
00–01h	VID	Vendor Identification	8086h	RO
02–03h	DID	Device Identification	See register description	RO
04–05h	PCICMD	PCI Command	0000h	R/W, RO
06–07h	PCISTS	PCI Status	0280h	R/WC, RO
08h	RID	Revision Identification	See register description	RO
09h	PI	Programming Interface	00h	RO
0Ah	SCC	Sub Class Code	03h	RO
0Bh	BCC	Base Class Code	0Ch	RO
0Dh	MLT	Master Latency Timer	00h	RO
0Eh	HEADTYP	Header Type	See register description	RO
20–23h	BASE	Base Address	00000001h	R/W, RO
2C–2Dh	SVID	Subsystem Vendor Identification	0000h	R/WO
2E–2Fh	SID	Subsystem Identification	0000h	R/WO
3Ch	INT_LN	Interrupt Line	00h	R/W



**Table 130. UHCI Controller PCI Register Address Map (USB—D29:F0/F1/F2, D26:F0/F1) (Sheet 2 of 2)**

Offset	Mnemonic	Register Name	UHCI #1–5 Default	Type
3Dh	INT_PN	Interrupt Pin	See register description	RO
60h	USB_RELNUM	Serial Bus Release Number	10h	RO
C0–C1h	USB_LEGKEY	USB Legacy Keyboard/Mouse Control	2000h	R/W, RO R/WC
C4h	USB_RES	USB Resume Enable	00h	R/W
C8h	CWP	Core Well Policy	00h	R/W

**NOTE:** Refer to the *Intel® ICH8 Family Specification Update* for the value of the Revision ID Register.

### 14.1.1 VID—Vendor Identification Register (USB—D29:F0/F1/F2, D26:F0/F1)

Address Offset: 00h–01h                      Attribute: RO  
 Default Value: 8086h                        Size: 16 bits

Bit	Description
15:0	Vendor ID — RO. This is a 16-bit value assigned to Intel

### 14.1.2 DID—Device Identification Register (USB—D29:F0/F1/F2, D26:F0/F1)

Address Offset: 02h–03h                      Attribute: RO  
 Default Value: See bit description        Size: 16 bits

Bit	Description
15:0	Device ID — RO. This is a 16-bit value assigned to the Intel® ICH8 USB universal host controllers. Refer to the <i>Intel ICH8 Family Specification Update</i> for the value of the Device ID Register.



### 14.1.3 PCI\_CMD—PCI Command Register (USB—D29:F0/F1/F2, D26:F0/F1)

Address Offset: 04h–05h      Attribute: R/W, RO  
 Default Value: 0000h      Size: 16 bits

Bit	Description
15:11	Reserved
10	<p><b>Interrupt Disable</b> — R/W.            0 = Enable. The function is able to generate its interrupt to the interrupt controller.            1 = Disable. The function is not capable of generating interrupts.</p> <p><b>NOTE:</b> The corresponding Interrupt Status bit is not affected by the interrupt enable.</p>
9	Fast Back to Back Enable (FBE) — RO. Hardwired to 0.
8	SERR# Enable — RO. Reserved as 0.
7	Wait Cycle Control (WCC) — RO. Hardwired to 0.
6	Parity Error Response (PER) — RO. Hardwired to 0.
5	VGA Palette Snoop (VPS) — RO. Hardwired to 0.
4	Postable Memory Write Enable (PMWE) — RO. Hardwired to 0.
3	Special Cycle Enable (SCE) — RO. Hardwired to 0.
2	<p><b>Bus Master Enable (BME)</b> — R/W.            0 = Disable            1 = Enable. ICH8 can act as a master on the PCI bus for USB transfers.</p>
1	Memory Space Enable (MSE) — RO. Hardwired to 0.
0	<p><b>I/O Space Enable (IOSE)</b> — R/W. This bit controls access to the I/O space registers.            0 = Disable            1 = Enable accesses to the USB I/O registers. The Base Address register for USB should be programmed before this bit is set.</p>



### 14.1.4 PCISTS—PCI Status Register (USB—D29:F0/F1/F2, D26:F0/F1)

Address Offset: 06h–07h                      Attribute: R/WC, RO  
 Default Value: 0280h                      Size: 16 bits

**Note:** For the writable bits, software must write a 1 to clear bits that are set. Writing a 0 to the bit has no effect.

Bit	Description
15	<b>Detected Parity Error (DPE)</b> — R/WC. 0 = No parity error detected. 1 = Set when a data parity error data parity error is detected on writes to the UHCI register space or on read completions returned to the host controller.
14	Reserved as 0b. Read Only.
13	<b>Received Master Abort (RMA)</b> — R/WC. 0 = No master abort generated by USB. 1 = USB, as a master, generated a master abort.
12	Reserved. Always read as 0.
11	<b>Signaled Target Abort (STA)</b> — R/WC. 0 = ICH8 did Not terminate transaction for USB function with a target abort. 1 = USB function is targeted with a transaction that the ICH8 terminates with a target abort.
10:9	<b>DEVSEL# Timing Status (DEV_STS)</b> — RO. This 2-bit field defines the timing for DEVSEL# assertion. These read only bits indicate the ICH8's DEVSEL# timing when performing a positive decode. ICH8 generates DEVSEL# with medium timing for USB.
8	Data Parity Error Detected (DPED) — RO. Hardwired to 0.
7	Fast Back to Back Capable (FB2BC) — RO. Hardwired to 1.
6	User Definable Features (UDF) — RO. Hardwired to 0.
5	66 MHz Capable — RO. Hardwired to 0.
4	Capabilities List — RO. Hardwired to 0.
3	<b>Interrupt Status</b> — RO. This bit reflects the state of this function's interrupt at the input of the enable/disable logic. 0 = Interrupt is deasserted. 1 = Interrupt is asserted. The value reported in this bit is independent of the value in the Interrupt Enable bit.
2:0	Reserved

### 14.1.5 RID—Revision Identification Register (USB—D29:F0/F1/F2, D26:F0/F1)

Offset Address: 08h                      Attribute: RO  
 Default Value: See bit description                      Size: 8 bits

Bit	Description
7:0	Revision ID — RO. Refer to the <i>Intel® I/O Controller Hub 8 (ICH8) Family Specification Update</i> for the value of the Revision ID Register







### 14.1.10 HEADTYP—Header Type Register (USB—D29:F0/F1/F2, D26:F0/F1)

Address Offset: 0Eh                      Attribute: RO  
 Default Value: See Bit Description      Size: 8 bits

For UHCI #2, 3, and 5 this register is hardwired to 00h. For UHCI #1 and UHCI #4, bit 7 is determined by the values in the USB Function Disable bits (11:8 of the Function Disable register Chipset Configuration Registers: Offset 3418h).

Bit	Description
7	<b>Multi-Function Device</b> — RO. Since the upper functions in this device can be individually hidden, this bit is based on the function-disable bits in Chipset Config Space: Offset 3418h as follows: 0 = Single-function device. (Default for UHCI #2,3 and5) 1 = Multi-function device. (Default for UHCI #1 and 4)
6:0	Configuration Layout. Hardwired to 00h, which indicates the standard PCI configuration layout.

### 14.1.11 BASE—Base Address Register (USB—D29:F0/F1/F2, D26:F0/F1)

Address Offset: 20h–23h                      Attribute: R/W, RO  
 Default Value: 00000001h                  Size: 32 bits

Bit	Description
31:16	Reserved
15:5	<b>Base Address</b> — R/W. Bits [15:5] correspond to I/O address signals AD [15:5], respectively. This gives 32 bytes of relocatable I/O space.
4:1	Reserved
0	Resource Type Indicator (RTE) — RO. Hardwired to 1 to indicate that the base address field in this register maps to I/O space.

### 14.1.12 SVID — Subsystem Vendor Identification Register (USB—D29:F0/F1/F2, D26:F0/F1)

Address Offset: 2Ch–2Dh                      Attribute: R/WO  
 Default Value: 0000h                      Size: 16 bits  
 Lockable: No                                  Power Well: Core

Bit	Description
15:0	Subsystem Vendor ID (SVID) — R/WO. BIOS sets the value in this register to identify the Subsystem Vendor ID. The USB_SVID register, in combination with the USB Subsystem ID register, enables the operating system to distinguish each subsystem from the others.  <b>NOTE:</b> The software can write to this register only once per core well reset. Writes should be done as a single, 16-bit cycle.



### 14.1.13 SID — Subsystem Identification Register (USB—D29:F0/F1/F2/F3, D26:F0/F1)

Address Offset:	2Eh–2Fh	Attribute:	R/WO
Default Value:	0000h	Size:	16 bits
Lockable:	No	Power Well:	Core

Bit	Description
15:0	<p><b>Subsystem ID (SID)</b> — R/WO. BIOS sets the value in this register to identify the Subsystem ID. The SID register, in combination with the SVID register (D29:F0/F1/F2, D26:F0/F1:2C), enables the operating system to distinguish each subsystem from other(s). The value read in this register is the same as what was written to the IDE_SID register.</p> <p><b>NOTE:</b> The software can write to this register only once per core well reset. Writes should be done as a single, 16-bit cycle.</p>

### 14.1.14 INT\_LN—Interrupt Line Register (USB—D29:F0/F1/F2, D26:F0/F1)

Address Offset:	3Ch	Attribute:	R/W
Default Value:	00h	Size:	8 bits

Bit	Description
7:0	<p><b>Interrupt Line (INT_LN)</b> — RO. This data is not used by the ICH8. It is to communicate to software the interrupt line that the interrupt pin is connected to.</p>

### 14.1.15 INT\_PN—Interrupt Pin Register (USB—D29:F0/F1/F2/F3, D26:F0/F1)

Address Offset:	3Dh	Attribute:	RO
Default Value:	See Description	Size:	8 bits

Bit	Description
7:0	<p><b>Interrupt Line (INT_LN)</b> — RO. This value tells the software which interrupt pin each USB host controller uses. The upper 4 bits are hardwired to 0000b; the lower 4 bits are determine by the Interrupt Pin default values that are programmed in the memory-mapped configuration space as follows:</p> <p>UHCI #1 - D29IP.U0P (Chipset Config Registers: Offset 3108:bits 3:0)                      UHCI #2 - D29IP.U1P (Chipset Config Registers: Offset 3108:bits 7:4)                      UHCI #3 - D29IP.U2P (Chipset Config Registers: Offset 3108:bits 11:8)                      UHCI #4 - D26IP.U0P (Chipset Config Registers: Offset 3114:bits 3:0)                      UHCI #5 - D26IP.U1P (Chipset Config Registers: Offset 3114:bits 7:4)</p> <p><b>NOTE:</b> This does not determine the mapping to the PIRQ pins.</p>



### 14.1.16 USB\_RELNUM—Serial Bus Release Number Register (USB—D29:F0/F1/F2, D26:F0/F1)

Address Offset: 60h Attribute: RO  
 Default Value: 10h Size: 8 bits

Bit	Description
7:0	<b>Serial Bus Release Number</b> — RO. 10h = USB controller supports the <i>USB Specification</i> , Release 1.0.

### 14.1.17 USB\_LEGKEY—USB Legacy Keyboard/Mouse Control Register (USB—D29:F0/F1/F2, D26:F0/F1)

Address Offset: C0h–C1h Attribute: R/W, R/WC, RO  
 Default Value: 2000h Size: 16 bits

This register is implemented separately in each of the USB UHCI functions. However, the enable and status bits for the trapping logic are OR'd and shared, respectively, since their functionality is not specific to any one host controller.

Bit	Description
15	<b>SMI Caused by End of Pass-Through (SMIBYENDPS)</b> — R/WC. This bit indicates if the event occurred. Note that even if the corresponding enable bit is not set in bit 7, then this bit will still be active. It is up to the SMM code to use the enable bit to determine the exact cause of the SMI#. 0 = Software clears this bit by writing a 1 to the bit location in any of the controllers. 1 = Event Occurred
14	Reserved
13	<b>PCI Interrupt Enable (USBPIRQEN)</b> — R/W. This bit is used to prevent the USB controller from generating an interrupt due to transactions on its ports. Note that, when disabled, it will probably be configured to generate an SMI using bit 4 of this register. Default to 1 for compatibility with older USB software. 0 = Disable 1 = Enable
12	<b>SMI Caused by USB Interrupt (SMIBYUSB)</b> — RO. This bit indicates if an interrupt event occurred from this controller. The interrupt from the controller is taken before the enable in bit 13 has any effect to create this read-only bit. Note that even if the corresponding enable bit is not set in Bit 4, this bit may still be active. It is up to the SMM code to use the enable bit to determine the exact cause of the SMI#. 0 = Software should clear the interrupts via the USB controllers. Writing a 1 to this bit will have no effect. 1 = Event Occurred.
11	<b>SMI Caused by Port 64 Write (TRAPBY64W)</b> — R/WC. This bit indicates if the event occurred. Note that even if the corresponding enable bit is not set in bit 3, this bit will still be active. It is up to the SMM code to use the enable bit to determine the exact cause of the SMI#. Note that the A20Gate Pass-Through Logic allows specific port 64h writes to complete without setting this bit. 0 = Software clears this bit by writing a 1 to the bit location in any of the controllers. 1 = Event Occurred.



Bit	Description
10	<p><b>SMI Caused by Port 64 Read (TRAPBY64R)</b> — R/WC. This bit indicates if the event occurred. Note that even if the corresponding enable bit is not set in bit 2, this bit will still be active. It is up to the SMM code to use the enable bit to determine the exact cause of the SMI#.</p> <p>0 = Software clears this bit by writing a 1 to the bit location in any of the controllers. 1 = Event Occurred.</p>
9	<p><b>SMI Caused by Port 60 Write (TRAPBY60W)</b> — R/WC. This bit indicates if the event occurred. Note that even if the corresponding enable bit is not set in bit 1, this bit will still be active. It is up to the SMM code to use the enable bit to determine the exact cause of the SMI#. Note that the A20Gate Pass-Through Logic allows specific port 64h writes to complete without setting this bit.</p> <p>0 = Software clears this bit by writing a 1 to the bit location in any of the controllers. 1 = Event Occurred.</p>
8	<p><b>SMI Caused by Port 60 Read (TRAPBY60R)</b> — R/WC. This bit indicates if the event occurred. Note that even if the corresponding enable bit is not set in the bit 0, then this bit will still be active. It is up to the SMM code to use the enable bit to determine the exact cause of the SMI#.</p> <p>0 = Software clears this bit by writing a 1 to the bit location in any of the controllers. 1 = Event Occurred.</p>
7	<p><b>SMI at End of Pass-Through Enable (SMIATENDPS)</b> — R/W. This bit enables SMI at the end of a pass-through. This can occur if an SMI is generated in the middle of a pass-through, and needs to be serviced later.</p> <p>0 = Disable 1 = Enable</p>
6	<p><b>Pass Through State (PSTATE)</b> — RO.</p> <p>0 = If software needs to reset this bit, it should set bit 5 in all of the host controllers to 0. 1 = Indicates that the state machine is in the middle of an A20GATE pass-through sequence.</p>
5	<p><b>A20Gate Pass-Through Enable (A20PASSEN)</b> — R/W.</p> <p>0 = Disable. 1 = Enable. Allows A20GATE sequence Pass-Through function. A specific cycle sequence involving writes to port 60h and 64h does not result in the setting of the SMI status bits.</p>
4	<p><b>SMI on USB IRQ Enable (USBSMIEN)</b> — R/W.</p> <p>0 = Disable 1 = Enable. USB interrupt will cause an SMI event.</p>
3	<p><b>SMI on Port 64 Writes Enable (64WEN)</b> — R/W.</p> <p>0 = Disable 1 = Enable. A 1 in bit 11 will cause an SMI event.</p>
2	<p><b>SMI on Port 64 Reads Enable (64REN)</b> — R/W.</p> <p>0 = Disable 1 = Enable. A 1 in bit 10 will cause an SMI event.</p>
1	<p><b>SMI on Port 60 Writes Enable (60WEN)</b> — R/W.</p> <p>0 = Disable 1 = Enable. A 1 in bit 9 will cause an SMI event.</p>
0	<p><b>SMI on Port 60 Reads Enable (60REN)</b> — R/W.</p> <p>0 = Disable 1 = Enable. A 1 in bit 8 will cause an SMI event.</p>





## 14.2 USB I/O Registers

Some of the read/write register bits that deal with changing the state of the USB hub ports function such that on read back they reflect the current state of the port, and not necessarily the state of the last write to the register. This allows the software to poll the state of the port and wait until it is in the proper state before proceeding. A host controller reset, global reset, or port reset will immediately terminate a transfer on the affected ports and disable the port. This affects the USBCMD register, bit 4 and the PORTSC registers, bits [12,6,2]. See individual bit descriptions for more detail.

**Table 131. USB I/O Registers**

BASE + Offset	Mnemonic	Register Name	Default	Type
00–01h	USBCMD	USB Command	0000h	R/W
02–03h	USBSTS	USB Status	0020h	R/WC
04–05h	USBINTR	USB Interrupt Enable	0000h	R/W
06–07h	FRNUM	Frame Number	0000h	R/W (see Note 1)
08–0Bh	FRBASEADD	Frame List Base Address	Undefined	R/W
0Ch	SOFMOD	Start of Frame Modify	40h	R/W
0D–0Fh	—	Reserved	—	—
10–11h	PORTSC0	Port 0 Status/Control	0080h	R/WC, RO, R/W (see Note 1)
12–13h	PORTSC1	Port 1 Status/Control	0080h	R/WC, RO, R/W (see Note 1)

**NOTES:**

1. These registers are WORD writable only. Byte writes to these registers have unpredictable effects.



### 14.2.1 USBCMD—USB Command Register

I/O Offset:            BASE + (00h–01h)            Attribute:            R/W  
 Default Value:        0000h                            Size:                 16 bits

The Command Register indicates the command to be executed by the serial bus host controller. Writing to the register causes a command to be executed. [Table 132](#) provides additional information on the operation of the Run/Stop and Debug bits.

Bit	Description
15:7	Reserved
8	<b>Loop Back Test Mode</b> — R/W. 0 = Disable loop back test mode. 1 = ICH8 is in loop back test mode. When both ports are connected together, a write to one port will be seen on the other port and the data will be stored in I/O offset 18h.
7	<b>Max Packet (MAXP)</b> — R/W. This bit selects the maximum packet size that can be used for full speed bandwidth reclamation at the end of a frame. This value is used by the host controller to determine whether it should initiate another transaction based on the time remaining in the SOF counter. Use of reclamation packets larger than the programmed size will cause a Babble error if executed during the critical window at frame end. The Babble error results in the offending endpoint being stalled. Software is responsible for ensuring that any packet which could be executed under bandwidth reclamation be within this size limit. 0 = 32 bytes 1 = 64 bytes
6	<b>Configure Flag (CF)</b> — R/W. This bit has no effect on the hardware. It is provided only as a semaphore service for software. 0 = Indicates that software has not completed host controller configuration. 1 = HCD software sets this bit as the last action in its process of configuring the host controller.
5	<b>Software Debug (SWDBG)</b> — R/W. The SWDBG bit must only be manipulated when the controller is in the stopped state. This can be determined by checking the HCHalted bit in the USBSTS register. 0 = Normal Mode. 1 = Debug mode. In SW Debug mode, the host controller clears the Run/Stop bit after the completion of each USB transaction. The next transaction is executed when software sets the Run/Stop bit back to 1.
4	<b>Force Global Resume (FGR)</b> — R/W. 0 = Software resets this bit to 0 after 20 ms has elapsed to stop sending the Global Resume signal. At that time all USB devices should be ready for bus activity. The 1 to 0 transition causes the port to send a low speed EOP signal. This bit will remain a 1 until the EOP has completed. 1 = Host controller sends the Global Resume signal on the USB, and sets this bit to 1 when a resume event (connect, disconnect, or K-state) is detected while in global suspend mode.
3	<b>Enter Global Suspend Mode (EGSM)</b> — R/W. 0 = Software resets this bit to 0 to come out of Global Suspend mode. Software writes this bit to 0 at the same time that Force Global Resume (bit 4) is written to 0 or after writing bit 4 to 0. 1 = Host controller enters the Global Suspend mode. No USB transactions occur during this time. The Host controller is able to receive resume signals from USB and interrupt the system. Software must ensure that the Run/Stop bit (bit 0) is cleared prior to setting this bit.





Bit	Description
2	<p><b>Global Reset (GRESET)</b> — R/W.</p> <p>0 = This bit is reset by the software after a minimum of 10 ms has elapsed as specified in Chapter 7 of the USB Specification.</p> <p>1 = Global Reset. The host controller sends the global reset signal on the USB and then resets all its logic, including the internal hub registers. The hub registers are reset to their power on state. Chip Hardware Reset has the same effect as Global Reset (bit 2), except that the host controller does not send the Global Reset on USB.</p>
1	<p><b>Host Controller Reset (HCRESET)</b> — R/W. The effects of HCRESET on Hub registers are slightly different from Chip Hardware Reset and Global USB Reset. The HCRESET affects bits [8,3:0] of the Port Status and Control Register (PORTSC) of each port. HCRESET resets the state machines of the host controller including the Connect/Disconnect state machine (one for each port). When the Connect/Disconnect state machine is reset, the output that signals connect/disconnect are negated to 0, effectively signaling a disconnect, even if a device is attached to the port. This virtual disconnect causes the port to be disabled. This disconnect and disabling of the port causes bit 1 (connect status change) and bit 3 (port enable/disable change) of the PORTSC to get set. The disconnect also causes bit 8 of PORTSC to reset. About 64 bit times after HCRESET goes to 0, the connect and low-speed detect will take place, and bits 0 and 8 of the PORTSC will change accordingly.</p> <p>0 = Reset by the host controller when the reset process is complete.</p> <p>1 = Reset. When this bit is set, the host controller module resets its internal timers, counters, state machines, etc. to their initial value. Any transaction currently in progress on USB is immediately terminated.</p>
0	<p><b>Run/Stop (RS)</b> — R/W. When set to 1, the ICH8 proceeds with execution of the schedule. The ICH8 continues execution as long as this bit is set. When this bit is cleared, the ICH8 completes the current transaction on the USB and then halts. The HC Halted bit in the status register indicates when the host controller has finished the transaction and has entered the stopped state. The host controller clears this bit when the following fatal errors occur: consistency check failure, PCI Bus errors.</p> <p>0 = Stop</p> <p>1 = Run</p> <p><b>NOTE:</b> This bit should only be cleared if there are no active Transaction Descriptors in the executable schedule or software will reset the host controller prior to setting this bit again.</p>

**Table 132. Run/Stop, Debug Bit Interaction SWDBG (Bit 5), Run/Stop (Bit 0) Operation**

SWDBG (Bit 5)	Run/Stop (Bit 0)	Description
0	0	If executing a command, the host controller completes the command and then stops. The 1.0 ms frame counter is reset and command list execution resumes from start of frame using the frame list pointer selected by the current value in the FRNUM register. (While Run/Stop=0, the FRNUM register (BASE + 06h) can be reprogrammed).
0	1	Execution of the command list resumes from Start Of Frame using the frame list pointer selected by the current value in the FRNUM register. The host controller remains running until the Run/Stop bit is cleared (by software or hardware).
1	0	If executing a command, the host controller completes the command and then stops and the 1.0 ms frame counter is frozen at its current value. All status are preserved. The host controller begins execution of the command list from where it left off when the Run/Stop bit is set.
1	1	Execution of the command list resumes from where the previous execution stopped. The Run/Stop bit is set to 0 by the host controller when a TD is being fetched. This causes the host controller to stop again after the execution of the TD (single step). When the host controller has completed execution, the HC Halted bit in the Status Register is set.

When the USB host controller is in Software Debug Mode (USBCMD Register bit 5=1), the single stepping software debug operation is as follows:

To Enter Software Debug Mode:

1. HCD puts host controller in Stop state by setting the Run/Stop bit to 0.
2. HCD puts host controller in Debug Mode by setting the SWDBG bit to 1.
3. HCD sets up the correct command list and Start Of Frame value for starting point in the Frame List Single Step Loop.
4. HCD sets Run/Stop bit to 1.
5. Host controller executes next active TD, sets Run/Stop bit to 0, and stops.
6. HCD reads the USBCMD register to check if the single step execution is completed (HCHalted=1).
7. HCD checks results of TD execution. Go to step 4 to execute next TD or step 8 to end Software Debug mode.
8. HCD ends Software Debug mode by setting SWDBG bit to 0.
9. HCD sets up normal command list and Frame List table.
10. HCD sets Run/Stop bit to 1 to resume normal schedule execution.

In Software Debug mode, when the Run/Stop bit is set, the host controller starts. When a valid TD is found, the Run/Stop bit is reset. When the TD is finished, the HCHalted bit in the USBSTS register (bit 5) is set.

The SW Debug mode skips over inactive TDs and only halts after an active TD has been executed. When the last active TD in a frame has been executed, the host controller waits until the next SOF is sent and then fetches the first TD of the next frame before halting.



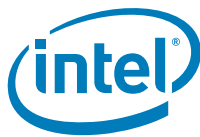
This HCHalted bit can also be used outside of Software Debug mode to indicate when the host controller has detected the Run/Stop bit and has completed the current transaction. Outside of the Software Debug mode, setting the Run/Stop bit to 0 always resets the SOF counter so that when the Run/Stop bit is set the host controller starts over again from the frame list location pointed to by the Frame List Index (see FRNUM Register description) rather than continuing where it stopped.

## 14.2.2 USBSTS—USB Status Register

I/O Offset:            BASE + (02h–03h)            Attribute:            R/WC  
 Default Value:        0020h                            Size:                 16 bits

This register indicates pending interrupts and various states of the host controller. The status resulting from a transaction on the serial bus is not indicated in this register.

Bit	Description
15:6	Reserved
5	<b>HCHalted</b> — R/WC. 0 = Software clears this bit by writing a 1 to it. 1 = The host controller has stopped executing as a result of the Run/Stop bit being set to 0, either by software or by the host controller hardware (debug mode or an internal error). Default.
4	<b>Host Controller Process Error</b> — R/WC. 0 = Software clears this bit by writing a 1 to it. 1 = The host controller has detected a fatal error. This indicates that the host controller suffered a consistency check failure while processing a Transfer Descriptor. An example of a consistency check failure would be finding an invalid PID field while processing the packet header portion of the TD. When this error occurs, the host controller clears the Run/Stop bit in the Command register (D29:F0/F1/F2, D26:F0/F1:BASE + 00h, bit 0) to prevent further schedule execution. A hardware interrupt is generated to the system.
3	<b>Host System Error</b> — R/WC. 0 = Software clears this bit by writing a 1 to it. 1 = A serious error occurred during a host system access involving the host controller module. In a PCI system, conditions that set this bit to 1 include PCI Parity error, PCI Master Abort, and PCI Target Abort. When this error occurs, the host controller clears the Run/Stop bit in the Command register to prevent further execution of the scheduled TDs. A hardware interrupt is generated to the system.
2	<b>Resume Detect (RSM_DET)</b> — R/WC. 0 = Software clears this bit by writing a 1 to it. 1 = The host controller received a “RESUME” signal from a USB device. This is only valid if the Host controller is in a global suspend state (Command register, D29:F0/F1/F2, D26:F0/F1:BASE + 00h, bit 3 = 1).
1	<b>USB Error Interrupt</b> — R/WC. 0 = Software clears this bit by writing a 1 to it. 1 = Completion of a USB transaction resulted in an error condition (e.g., error counter underflow). If the TD on which the error interrupt occurred also had its IOC bit (D29:F0/F1/F2, D26:F0/F1:BASE + 04h, bit 2) set, both this bit and Bit 0 are set.
0	<b>USB Interrupt (USBINT)</b> — R/WC. 0 = Software clears this bit by writing a 1 to it. 1 = The host controller sets this bit when the cause of an interrupt is a completion of a USB transaction whose Transfer Descriptor had its IOC bit set. Also set when a short packet is detected (actual length field in TD is less than maximum length field in TD), and short packet detection is enabled in that TD.



### 14.2.3 USBINTR—USB Interrupt Enable Register

I/O Offset:            BASE + (04h–05h)            Attribute:            R/W  
 Default Value:        0000h                                Size:                 16 bits

This register enables and disables reporting of the corresponding interrupt to the software. When a bit is set and the corresponding interrupt is active, an interrupt is generated to the host. Fatal errors (host controller processor error, (D29:F0/F1/F2, D26:F0/F1:BASE + 02h, bit 4, USBSTS Register) cannot be disabled by the host controller. Interrupt sources that are disabled in this register still appear in the Status Register to allow the software to poll for events.

Bit	Description
15:5	Reserved
4	<b>Scratchpad (SP)</b> — R/W.
3	<b>Short Packet Interrupt Enable</b> — R/W. 0 = Disabled. 1 = Enabled.
2	<b>Interrupt on Complete Enable (IOC)</b> — R/W. 0 = Disabled. 1 = Enabled.
1	<b>Resume Interrupt Enable</b> — R/W. 0 = Disabled. 1 = Enabled.
0	<b>Timeout/CRC Interrupt Enable</b> — R/W. 0 = Disabled. 1 = Enabled.

### 14.2.4 FRNUM—Frame Number Register

I/O Offset:            BASE + (06–07h)            Attribute:            R/W (Writes must be  
 Word Writes)  
 Default Value:        0000h                                Size:                 16 bits

Bits [10:0] of this register contain the current frame number that is included in the frame SOF packet. This register reflects the count value of the internal frame number counter. Bits [9:0] are used to select a particular entry in the Frame List during scheduled execution. This register is updated at the end of each frame time.

This register must be written as a word. Byte writes are not supported. This register cannot be written unless the host controller is in the STOPPED state as indicated by the HCHalted bit (D29:F0/F1/F2/, D26:F0/F1:BASE + 02h, bit 5). A write to this register while the Run/Stop bit is set (D29:F0/F1/F2/, D26:F0/F1:BASE + 00h, bit 0) is ignored.

Bit	Description
15:11	Reserved
10:0	<b>Frame List Current Index/Frame Number</b> — R/W. This field provides the frame number in the SOF Frame. The value in this register increments at the end of each time frame (approximately every 1 ms). In addition, bits [9:0] are used for the Frame List current index and correspond to memory address signals [11:2].



### 14.2.5 FRBASEADD—Frame List Base Address Register

I/O Offset:           BASE + (08h–0Bh)           Attribute:           R/W  
 Default Value:       Undefined                           Size:                32 bits

This 32-bit register contains the beginning address of the Frame List in the system memory. HCD loads this register prior to starting the schedule execution by the host controller. When written, only the upper 20 bits are used. The lower 12 bits are written as 0's (4 KB alignment). The contents of this register are combined with the frame number counter to enable the host controller to step through the Frame List in sequence. The two least significant bits are always 00. This requires dword-alignment for all list entries. This configuration supports 1024 Frame List entries.

Bit	Description
31:12	<b>Base Address</b> — R/W. These bits correspond to memory address signals [31:12], respectively.
11:0	Reserved

### 14.2.6 SOFMOD—Start of Frame Modify Register

I/O Offset:           Base + (0Ch)                           Attribute:           R/W  
 Default Value:       40h                                   Size:                8 bits

This 1-byte register is used to modify the value used in the generation of SOF timing on the USB. Only the 7 least significant bits are used. When a new value is written into these 7 bits, the SOF timing of the next frame will be adjusted. This feature can be used to adjust out any offset from the clock source that generates the clock that drives the SOF counter. This register can also be used to maintain real time synchronization with the rest of the system so that all devices have the same sense of real time. Using this register, the frame length can be adjusted across the full range required by the USB specification. Its initial programmed value is system dependent based on the accuracy of hardware USB clock and is initialized by system BIOS. It may be reprogrammed by USB system software at any time. Its value will take effect from the beginning of the next frame. This register is reset upon a host controller reset or global reset. Software must maintain a copy of its value for reprogramming if necessary.

Bit	Description																				
7	Reserved																				
6:0	<p><b>SOF Timing Value</b> — R/W. Guidelines for the modification of frame time are contained in Chapter 7 of the USB Specification. The SOF cycle time (number of SOF counter clock periods to generate a SOF frame length) is equal to 11936 + value in this field. The default value is decimal 64 which gives a SOF cycle time of 12000. For a 12 MHz SOF counter clock input, this produces a 1 ms Frame period. The following table indicates what SOF Timing Value to program into this field for a certain frame period.</p> <table border="1"> <thead> <tr> <th>Frame Length (# 12 MHz Clocks) (decimal)</th> <th>SOF Timing Value (this register) (decimal)</th> </tr> </thead> <tbody> <tr><td>11936</td><td>0</td></tr> <tr><td>11937</td><td>1</td></tr> <tr><td>—</td><td>—</td></tr> <tr><td>11999</td><td>63</td></tr> <tr><td>12000</td><td>64</td></tr> <tr><td>12001</td><td>65</td></tr> <tr><td>—</td><td>—</td></tr> <tr><td>12062</td><td>126</td></tr> <tr><td>12063</td><td>127</td></tr> </tbody> </table>	Frame Length (# 12 MHz Clocks) (decimal)	SOF Timing Value (this register) (decimal)	11936	0	11937	1	—	—	11999	63	12000	64	12001	65	—	—	12062	126	12063	127
Frame Length (# 12 MHz Clocks) (decimal)	SOF Timing Value (this register) (decimal)																				
11936	0																				
11937	1																				
—	—																				
11999	63																				
12000	64																				
12001	65																				
—	—																				
12062	126																				
12063	127																				



### 14.2.7 PORTSC[0,1]—Port Status and Control Register

I/O Offset:	Port 0/2/4/6/8: BASE + (10h–11h)	Attribute: R/WC, RO,
	Port 1/3/5/7/9: BASE + (12h–13h)	R/W (Word writes only)
Default Value:	0080h	Size: 16 bits

**Note:** For UHCI #1 (D29:F0), this applies to ICH8 USB ports 0 and 1; for UHCI #2 (D29:F1), this applies to ICH8 USB ports 2 and 3; for UHCI #3 (D29:F2), this applies to ICH8 USB ports 4 and 5, for UHCI #4 (D26:F0), this applies to ICH8 USB ports 6 and 7, and for UHCI #5 (D26:F1), this applies to ICH8 USB ports 8 and 9.

After a power-up reset, global reset, or host controller reset, the initial conditions of a port are: no device connected, Port disabled, and the bus line status is 00 (single-ended 0).

#### Port Reset and Enable Sequence

When software wishes to reset a USB device it will assert the Port Reset bit in the Port Status and Control register. The minimum reset signaling time is 10 mS and is enforced by software. To complete the reset sequence, software clears the port reset bit. The Intel UHCI controller must re-detect the port connect after reset signaling is complete before the controller will allow the port enable bit to be set by software. This time is approximately 5.3  $\mu$ S. Software has several possible options to meet the timing requirement and a partial list is enumerated below:

- Iterate a short wait, setting the port enable bit and reading it back to see if the enable bit is set.
- Poll the connect status bit and wait for the hardware to recognize the connect prior to enabling the port.
- Wait longer than the hardware detect time after clearing the port reset and prior to enabling the port.



Bit	Description								
15:13	Reserved — RO.								
12	<p><b>Suspend</b> — R/W. This bit should not be written to a 1 if global suspend is active (bit 3 = 1 in the USBCMD register). Bit 2 and bit 12 of this register define the hub states as follows:</p> <table border="1"> <thead> <tr> <th>Bits [12,2]</th> <th>Hub State</th> </tr> </thead> <tbody> <tr> <td>X,0</td> <td>Disable</td> </tr> <tr> <td>0, 1</td> <td>Enable</td> </tr> <tr> <td>1, 1</td> <td>Suspend</td> </tr> </tbody> </table> <p>When in suspend state, downstream propagation of data is blocked on this port, except for single-ended 0 resets (global reset and port reset). The blocking occurs at the end of the current transaction, if a transaction was in progress when this bit was written to 1. In the suspend state, the port is sensitive to resume detection. Note that the bit status does not change until the port is suspended and that there may be a delay in suspending a port if there is a transaction currently in progress on the USB. 1 = Port in suspend state. 0 = Port not in suspend state.</p> <p><b>NOTE:</b> Normally, if a transaction is in progress when this bit is set, the port will be suspended when the current transaction completes. However, in the case of a specific error condition (out transaction with babble), the ICH8 may issue a start-of-frame, and then suspend the port.</p>	Bits [12,2]	Hub State	X,0	Disable	0, 1	Enable	1, 1	Suspend
Bits [12,2]	Hub State								
X,0	Disable								
0, 1	Enable								
1, 1	Suspend								
11	<p><b>Overcurrent Indicator</b> — R/WC. Set by hardware. 0 = Software clears this bit by writing a 1 to it. 1 = Overcurrent pin has gone from inactive to active on this port.</p>								
10	<p><b>Overcurrent Active</b> — RO. This bit is set and cleared by hardware. 0 = Indicates that the overcurrent pin is inactive (high). 1 = Indicates that the overcurrent pin is active (low).</p>								
9	<p><b>Port Reset</b> — R/W. 0 = Port is not in Reset. 1 = Port is in Reset. When set, the port is disabled and sends the USB Reset signaling.</p>								
8	<p><b>Low Speed Device Attached (LS)</b> — RO. 0 = Full speed device is attached. 1 = Low speed device is attached to this port.</p>								
7	Reserved — RO. Always read as 1.								
6	<p><b>Resume Detect (RSM_DET)</b> — R/W. Software sets this bit to a 1 to drive resume signaling. The host controller sets this bit to a 1 if a J-to-K transition is detected for at least 32 microseconds while the port is in the Suspend state. The ICH8 will then reflect the K-state back onto the bus as long as the bit remains a 1, and the port is still in the suspend state (bit 12,2 are '11'). Writing a 0 (from 1) causes the port to send a low speed EOP. This bit will remain a 1 until the EOP has completed. 0 = No resume (K-state) detected/driven on port. 1 = Resume detected/driven on port.</p>								
5:4	<p><b>Line Status</b> — RO. These bits reflect the D+ (bit 4) and D- (bit 5) signals lines' logical levels. These bits are used for fault detect and recovery as well as for USB diagnostics. This field is updated at EOF2 time (See Chapter 11 of the USB Specification).</p>								
3	<p><b>Port Enable/Disable Change</b> — R/WC. For the root hub, this bit gets set only when a port is disabled due to disconnect on that port or due to the appropriate conditions existing at the EOF2 point (See Chapter 11 of the USB Specification). 0 = No change. Software clears this bit by writing a 1 to the bit location. 1 = Port enabled/disabled status has changed.</p>								



Bit	Description
2	<b>Port Enabled/Disabled (PORT_EN)</b> — R/W. Ports can be enabled by host software only. Ports can be disabled by either a fault condition (disconnect event or other fault condition) or by host software. Note that the bit status does not change until the port state actually changes and that there may be a delay in disabling or enabling a port if there is a transaction currently in progress on the USB. 0 = Disable 1 = Enable
1	<b>Connect Status Change</b> — R/WC. This bit indicates that a change has occurred in the port's Current Connect Status (see bit 0). The hub device sets this bit for any changes to the port device connect status, even if system software has not cleared a connect status change. If, for example, the insertion status changes twice before system software has cleared the changed condition, hub hardware will be setting an already-set bit (i.e., the bit will remain set). However, the hub transfers the change bit only once when the host controller requests a data transfer to the Status Change endpoint. System software is responsible for determining state change history in such a case. 0 = No change. Software clears this bit by writing a 1 to it. 1 = Change in Current Connect Status.
0	<b>Current Connect Status</b> — RO. This value reflects the current state of the port, and may not correspond directly to the event that caused the Connect Status Change bit (Bit 1) to be set. 0 = No device is present. 1 = Device is present on port.

§ §





# 15 EHCI Controller Registers (D29:F7, D26:F7)

## 15.1 USB EHCI Configuration Registers (USB EHCI—D29:F7, D26:F7)

**Note:** Register address locations that are not shown in Table 133 should be treated as Reserved (see Section 6.2 for details).

**Table 133. USB EHCI PCI Register Address Map (USB EHCI—D29:F7, D26:F7) (Sheet 1 of 2)**

Offset	Mnemonic	Register Name	Default	Type
00h–01h	VID	Vendor Identification	8086h	RO
02h–03h	DID	Device Identification	See register description	RO
04h–05h	PCICMD	PCI Command	0000h	R/W, RO
06h–07h	PCISTS	PCI Status	0290h	R/W, RO
08h	RID	Revision Identification	See register description	RO
09h	PI	Programming Interface	20h	RO
0Ah	SCC	Sub Class Code	03h	RO
0Bh	BCC	Base Class Code	0Ch	RO
0Dh	PMLT	Primary Master Latency Timer	00h	RO
10h–13h	MEM_BASE	Memory Base Address	00000000h	R/W, RO
2Ch–2Dh	SVID	USB EHCI Subsystem Vendor Identification	XXXXh	R/W (special)
2Eh–2Fh	SID	USB EHCI Subsystem Identification	XXXXh	R/W (special)
34h	CAP_PTR	Capabilities Pointer	50h	RO
3Ch	INT_LN	Interrupt Line	00h	R/W
3Dh	INT_PN	Interrupt Pin	See register description	RO
50h	PWR_CAPID	PCI Power Management Capability ID	01h	RO
51h	NXT_PTR1	Next Item Pointer	58h	R/W (special)
52h–53h	PWR_CAP	Power Management Capabilities	C9C2h	R/W (special)
54h–55h	PWR_CNTL_STS	Power Management Control/Status	0000h	R/W, R/WC, RO
58h	DEBUG_CAPID	Debug Port Capability ID	0Ah	RO
59h	NXT_PTR2	Next Item Pointer #2	00h	RO



Table 133. USB EHCI PCI Register Address Map (USB EHCI—D29:F7, D26:F7) (Sheet 2 of 2)

Offset	Mnemonic	Register Name	Default	Type
5Ah–5Bh	DEBUG_BASE	Debug Port Base Offset	20A0h	RO
60h	USB_RELNUM	USB Release Number	20h	RO
61h	FL_ADJ	Frame Length Adjustment	20h	R/W
62h–63h	PWAKE_CAP	Port Wake Capabilities	01FFh	R/W
64h–67h	—	Reserved	—	—
68h–6Bh	LEG_EXT_CAP	USB EHCI Legacy Support Extended Capability	00000001h	R/W, RO
6Ch–6Fh	LEG_EXT_CS	USB EHCI Legacy Extended Support Control/Status	00000000h	R/W, R/WC, RO
70h–73h	SPECIAL_SMI	Intel Specific USB 2.0 SMI	00000000h	R/W, R/WC
74h–7Fh	—	Reserved	—	—
80h	ACCESS_CNTL	Access Control	00h	R/W
84h	EHCIIR1	EHCI Initialization Register 1 (Mobile Only)	01h	R/W, R/WL
FC–FFh	EHCIIR2	EHCI Initialization Register 2	20001706	R/W

**Note:** All configuration registers in this section are in the core well and reset by a core well reset and the D3-to-D0 warm reset, except as noted.

### 15.1.1 VID—Vendor Identification Register (USB EHCI—D29:F7, D26:F7)

Offset Address: 00h–01h                      Attribute: RO  
 Default Value: 8086h                        Size: 16 bits

Bit	Description
15:0	Vendor ID — RO. This is a 16-bit value assigned to Intel.

### 15.1.2 DID—Device Identification Register (USB EHCI—D29:F7, D26:F7)

Offset Address: 02h–03h                      Attribute: RO  
 Default Value: See bit description        Size: 16 bits

Bit	Description
15:0	Device ID — RO. This is a 16-bit value assigned to the Intel® ICH8 USB EHCI controller. Refer to the <i>Intel ICH8 Family Specification Update</i> for the value of the Device ID Register.



### 15.1.3 PCICMD—PCI Command Register (USB EHCI—D29:F7, D26:F7)

Address Offset: 04h–05h  
Default Value: 0000h

Attribute: R/W, RO  
Size: 16 bits

Bit	Description
15:11	Reserved
10	<p><b>Interrupt Disable</b> — R/W.</p> <p>0 = The function is capable of generating interrupts. 1 = The function can not generate its interrupt to the interrupt controller.</p> <p>Note that the corresponding Interrupt Status bit (D29:F7, D26:F7:06h, bit 3) is not affected by the interrupt enable.</p>
9	Fast Back to Back Enable (FBE) — RO. Hardwired to 0.
8	<p><b>SERR# Enable (SERR_EN)</b> — R/W.</p> <p>0 = Disables EHC's capability to generate an SERR#. 1 = The Enhanced Host controller (EHC) is capable of generating (internally) SERR# when it receive a completion status other than "successful" for one of its DMA-initiated memory reads on DMI (and subsequently on its internal interface).</p>
7	Wait Cycle Control (WCC) — RO. Hardwired to 0.
6	Parity Error Response (PER) — RO. Hardwired to 0.
5	VGA Palette Snoop (VPS) — RO. Hardwired to 0.
4	Postable Memory Write Enable (PMWE) — RO. Hardwired to 0.
3	Special Cycle Enable (SCE) — RO. Hardwired to 0.
2	<p><b>Bus Master Enable (BME)</b> — R/W.</p> <p>0 = Disables this functionality. 1 = Enables the ICH8 to act as a master on the PCI bus for USB transfers.</p>
1	<p><b>Memory Space Enable (MSE)</b> — R/W. This bit controls access to the USB 2.0 Memory Space registers.</p> <p>0 = Disables this functionality. 1 = Enables accesses to the USB 2.0 registers. The Base Address register (D29:F7, D26:F7:10h) for USB 2.0 should be programmed before this bit is set.</p>
0	I/O Space Enable (IOSE) — RO. Hardwired to 0.









### 15.1.12 SID—USB EHCI Subsystem ID Register (USB EHCI—D29:F7, D26:F7)

Address Offset: 2Eh–2Fh                                  Attribute: R/W (special)  
 Default Value: XXXXh                                  Size: 16 bits  
 Reset: None

Bit	Description
15:0	<p><b>Subsystem ID (SID)</b> — R/W (special). BIOS sets the value in this register to identify the Subsystem ID. This register, in combination with the Subsystem Vendor ID register, enables the operating system to distinguish each subsystem from other(s).</p> <p><b>NOTE:</b> Writes to this register are enabled when the WRT_RDONLY bit (D29:F7, D26:F7:80h, bit 0) is set to 1.</p>

### 15.1.13 CAP\_PTR—Capabilities Pointer Register (USB EHCI—D29:F7, D26:F7)

Address Offset: 34h    Attribute: RO  
 Default Value: 50h    Size: 8 bits

Bit	Description
7:0	Capabilities Pointer (CAP_PTR) — RO. This register points to the starting offset of the USB 2.0 capabilities ranges.

### 15.1.14 INT\_LN—Interrupt Line Register (USB EHCI—D29:F7, D26:F7)

Address Offset: 3Ch    Attribute: R/W  
 Default Value: 00h    Size: 8 bits

Bit	Description
7:0	<p><b>Interrupt Line (INT_LN)</b> — R/W. This data is not used by the Intel<sup>®</sup> ICH8. It is used as a scratchpad register to communicate to software the interrupt line that the interrupt pin is connected to.</p>

### 15.1.15 INT\_PN—Interrupt Pin Register (USB EHCI—D29:F7, D26:F7)

Address Offset: 3Dh    Attribute: RO  
 Default Value: See Description                          Size: 8 bits

Bit	Description
7:0	<p>Interrupt Pin — RO. This reflects the value of D29IP.EIP (Chipset Config Registers: Offset 3108: bits 31:28) or D26IP.EIP (Chipset Config Registers: Offset 3114: bits 31:28).</p> <p><b>NOTE:</b> Bits 7:4 are always 0h</p>









### 15.1.19 PWR\_CNTL\_STS—Power Management Control/Status Register (USB EHCI—D29:F7, D26:F7)

Address Offset: 54h–55h                      Attribute: R/W, R/WC, RO  
 Default Value: 0000h                      Size: 16 bits

Bit	Description
15	<p><b>PME Status</b> — R/WC.</p> <p>0 = Writing a 1 to this bit will clear it and cause the internal PME to deassert (if enabled).</p> <p>1 = This bit is set when the ICH8 EHC would normally assert the PME# signal independent of the state of the PME_En bit.</p> <p><b>NOTE:</b> This bit must be explicitly cleared by the operating system each time the operating system is loaded.</p>
14:13	Data Scale — RO. Hardwired to 00b indicating it does not support the associated Data register.
12:9	Data Select — RO. Hardwired to 0000b indicating it does not support the associated Data register.
8	<p><b>PME Enable</b> — R/W.</p> <p>0 = Disable.</p> <p>1 = Enable. Enables Intel® ICH8 EHC to generate an internal PME signal when PME_Status is 1.</p> <p><b>NOTE:</b> This bit must be explicitly cleared by the operating system each time it is initially loaded.</p>
7:2	Reserved
1:0	<p><b>Power State</b> — R/W. This 2-bit field is used both to determine the current power state of EHC function and to set a new power state. The definition of the field values are:</p> <p>00 = D0 state</p> <p>11 = D3<sub>HOT</sub> state</p> <p>If software attempts to write a value of 10b or 01b in to this field, the write operation must complete normally; however, the data is discarded and no state change occurs. When in the D3<sub>HOT</sub> state, the ICH8 must not accept accesses to the EHC memory range; but the configuration space must still be accessible. When not in the D0 state, the generation of the interrupt output is blocked. Specifically, the PIRQH is not asserted by the ICH8 when not in the D0 state.</p> <p>When software changes this value from the D3<sub>HOT</sub> state to the D0 state, an internal warm (soft) reset is generated, and software must re-initialize the function.</p>

**NOTE:** Reset (bits 15, 8): suspend well, and not D3-to-D0 warm reset nor core well reset.







### 15.1.25 PWAKE\_CAP—Port Wake Capability Register (USB EHCI—D29:F7, D26:F7)

Address Offset: 62–63h                      Attribute: R/W  
 Default Value: 01FFh                      Size: 16 bits

This register is in the suspend power well. The intended use of this register is to establish a policy about which ports are to be used for wake events. Bit positions 1–6(D29) or 1–4(D26) in the mask correspond to a physical port implemented on the current EHCI controller. A 1 in a bit position indicates that a device connected below the port can be enabled as a wake-up device and the port may be enabled for disconnect/connect or overcurrent events as wake-up events. This is an information-only mask register. The bits in this register **do not** affect the actual operation of the EHCI host controller. The system-specific policy can be established by BIOS initializing this register to a system-specific value. System software uses the information in this register when enabling devices and ports for remote wake-up.

These bits are not reset by a D3-to-D0 warm rest or a core well reset.

Bit	Description
15:7 (D29) 15:5 (D26)	Reserved — RO.
6:1 (D29) 4:1 (D26)	<b>Port Wake Up Capability Mask</b> — R/W. Bit positions 1 through 6 (Device 29) or 1 through 4 (Device 26) correspond to a physical port implemented on this host controller. For example, bit position 1 corresponds to port 1, bit position 2 corresponds to port 2, etc.
0	<b>Port Wake Implemented</b> — R/W. A 1 in this bit indicates that this register is implemented to software.

### 15.1.26 LEG\_EXT\_CAP—USB EHCI Legacy Support Extended Capability Register (USB EHCI—D29:F7, D26:F7)

Address Offset: 68–6Bh                      Attribute: R/W, RO  
 Default Value: 00000001h                  Size: 32 bits  
 Power Well: Suspend

**NOTE:** These bits are not reset by a D3-to-D0 warm rest or a core well reset.

Bit	Description
31:25	Reserved — RO. Hardwired to 00h
24	<b>HC OS Owned Semaphore</b> — R/W. System software sets this bit to request ownership of the EHCI controller. Ownership is obtained when this bit reads as 1 and the HC BIOS Owned Semaphore bit reads as clear.
23:17	Reserved — RO. Hardwired to 00h
16	<b>HC BIOS Owned Semaphore</b> — R/W. The BIOS sets this bit to establish ownership of the EHCI controller. System BIOS will clear this bit in response to a request for ownership of the EHCI controller by system software.
15:8	<b>Next EHCI Capability Pointer</b> — RO. Hardwired to 00h to indicate that there are no EHCI Extended Capability structures in this device.
7:0	<b>Capability ID</b> — RO. Hardwired to 01h to indicate that this EHCI Extended Capability is the Legacy Support Capability.



### 15.1.27 LEG\_EXT\_CS—USB EHCI Legacy Support Extended Control / Status Register (USB EHCI—D29:F7, D26:F7)

Address Offset: 6C–6Fh                      Attribute:                R/W, R/WC, RO  
 Default Value: 00000000h                Size:                     32 bits  
 Power Well:                    Suspend

**Note:** These bits are not reset by a D3-to-D0 warm rest or a core well reset.

Bit	Description
31	<b>SMI on BAR</b> — R/WC. Software clears this bit by writing a 1 to it. 0 = Base Address Register (BAR) not written. 1 = This bit is set to 1 when the Base Address Register (BAR) is written.
30	<b>SMI on PCI Command</b> — R/WC. Software clears this bit by writing a 1 to it. 0 = PCI Command (PCICMD) Register Not written. 1 = This bit is set to 1 when the PCI Command (PCICMD) Register is written.
29	<b>SMI on OS Ownership Change</b> — R/WC. Software clears this bit by writing a 1 to it. 0 = No HC OS Owned Semaphore bit change. 1 = This bit is set to 1 when the HC OS Owned Semaphore bit in the LEG_EXT_CAP register (D29:F7, D26:F7:68h, bit 24) transitions from 1 to 0 or 0 to 1.
28:22	Reserved — RO. Hardwired to 00h
21	<b>SMI on Async Advance</b> — RO. This bit is a shadow bit of the Interrupt on Async Advance bit (D29:F7, D26:F7:CAPLENGTH + 24h, bit 5) in the USB2.0_STS register. <b>NOTE:</b> To clear this bit system software must write a 1 to the Interrupt on Async Advance bit in the USB2.0_STS register.
20	<b>SMI on Host System Error</b> — RO. This bit is a shadow bit of Host System Error bit in the USB2.0_STS register (D29:F7, D26:F7:CAPLENGTH + 24h, bit 4). <b>NOTE:</b> To clear this bit system software must write a 1 to the Host System Error bit in the USB2.0_STS register.
19	<b>SMI on Frame List Rollover</b> — RO. This bit is a shadow bit of Frame List Rollover bit (D29:F7, D26:F7:CAPLENGTH + 24h, bit 3) in the USB2.0_STS register. <b>NOTE:</b> To clear this bit system software must write a 1 to the Frame List Rollover bit in the USB2.0_STS register.
18	<b>SMI on Port Change Detect</b> — RO. This bit is a shadow bit of Port Change Detect bit (D29:F7, D26:F7:CAPLENGTH + 24h, bit 2) in the USB2.0_STS register. <b>NOTE:</b> To clear this bit system software must write a 1 to the Port Change Detect bit in the USB2.0_STS register.
17	<b>SMI on USB Error</b> — RO. This bit is a shadow bit of USB Error Interrupt (USBERRINT) bit (D29:F7, D26:F7:CAPLENGTH + 24h, bit 1) in the USB2.0_STS register. <b>NOTE:</b> To clear this bit system software must write a 1 to the USB Error Interrupt bit in the USB2.0_STS register.
16	<b>SMI on USB Complete</b> — RO. This bit is a shadow bit of USB Interrupt (USBINT) bit (D29:F7, D26:F7:CAPLENGTH + 24h, bit 0) in the USB2.0_STS register. <b>NOTE:</b> To clear this bit system software must write a 1 to the USB Interrupt bit in the USB2.0_STS register.



Bit	Description
15	<b>SMI on BAR Enable</b> — R/W. 0 = Disable. 1 = Enable. When this bit is 1 and SMI on BAR (D29:F7, D26:F7:6Ch, bit 31) is 1, then the host controller will issue an SMI.
14	<b>SMI on PCI Command Enable</b> — R/W. 0 = Disable. 1 = Enable. When this bit is 1 and SMI on PCI Command (D29:F7, D26:F7:6Ch, bit 30) is 1, then the host controller will issue an SMI.
13	<b>SMI on OS Ownership Enable</b> — R/W. 0 = Disable. 1 = Enable. When this bit is a 1 AND the OS Ownership Change bit (D29:F7, D26:F7:6Ch, bit 29) is 1, the host controller will issue an SMI.
12:6	Reserved — RO. Hardwired to 00h
5	<b>SMI on Async Advance Enable</b> — R/W. 0 = Disable. 1 = Enable. When this bit is a 1, and the SMI on Async Advance bit (D29:F7, D26:F7:6Ch, bit 21) is a 1, the host controller will issue an SMI immediately.
4	<b>SMI on Host System Error Enable</b> — R/W. 0 = Disable. 1 = Enable. When this bit is a 1, and the SMI on Host System Error (D29:F7, D26:F7:6Ch, bit 20) is a 1, the host controller will issue an SMI.
3	<b>SMI on Frame List Rollover Enable</b> — R/W. 0 = Disable. 1 = Enable. When this bit is a 1, and the SMI on Frame List Rollover bit (D29:F7, D26:F7:6Ch, bit 19) is a 1, the host controller will issue an SMI.
2	<b>SMI on Port Change Enable</b> — R/W. 0 = Disable. 1 = Enable. When this bit is a 1, and the SMI on Port Change Detect bit (D29:F7, D26:F7:6Ch, bit 18) is a 1, the host controller will issue an SMI.
1	<b>SMI on USB Error Enable</b> — R/W. 0 = Disable. 1 = Enable. When this bit is a 1, and the SMI on USB Error bit (D29:F7, D26:F7:6Ch, bit 17) is a 1, the host controller will issue an SMI immediately.
0	<b>SMI on USB Complete Enable</b> — R/W. 0 = Disable. 1 = Enable. When this bit is a 1, and the SMI on USB Complete bit (D29:F7, D26:F7:6Ch, bit 16) is a 1, the host controller will issue an SMI immediately.



### 15.1.28 SPECIAL\_SMI—Intel Specific USB 2.0 SMI Register (USB EHCI—D29:F7, D26:F7)

Address Offset: 70h–73h      Attribute: R/W, R/WC  
 Default Value: 00000000h      Size: 32 bits  
 Power Well: Suspend

**Note:** These bits are not reset by a D3-to-D0 warm rest or a core well reset.

Bit	Description
31:28 (D29) 31:26 (D26)	Reserved — RO. Hardwired to 00h
27:22 (D29) 25:22 (D26)	<b>SMI on PortOwner</b> — R/WC. Software clears these bits by writing a 1 to it. 0 = No Port Owner bit change. 1 = Bits 27:22, 25:22 correspond to the Port Owner bits for ports 1 (22) through 4 (25) or 6 (27). These bits are set to 1 when the associated Port Owner bits transition from 0 to 1 or 1 to 0.
21	<b>SMI on PMCSR</b> — R/WC. Software clears these bits by writing a 1 to it. 0 = Power State bits Not modified. 1 = Software modified the Power State bits in the Power Management Control/Status (PMCSR) register (D29:F7, D26:F7:54h).
20	<b>SMI on Async</b> — R/WC. Software clears these bits by writing a 1 to it. 0 = No Async Schedule Enable bit change 1 = Async Schedule Enable bit transitioned from 1 to 0 or 0 to 1.
19	<b>SMI on Periodic</b> — R/WC. Software clears this bit by writing a 1 it. 0 = No Periodic Schedule Enable bit change. 1 = Periodic Schedule Enable bit transitions from 1 to 0 or 0 to 1.
18	<b>SMI on CF</b> — R/WC. Software clears this bit by writing a 1 it. 0 = No Configure Flag (CF) change. 1 = Configure Flag (CF) transitions from 1 to 0 or 0 to 1.
17	<b>SMI on HCHalted</b> — R/WC. Software clears this bit by writing a 1 it. 0 = HCHalted did Not transition to 1 (as a result of the Run/Stop bit being cleared). 1 = HCHalted transitions to 1 (as a result of the Run/Stop bit being cleared).
16	<b>SMI on HCRreset</b> — R/WC. Software clears this bit by writing a 1 it. 0 = HCRESET did Not transitioned to 1. 1 = HCRESET transitioned to 1.
15:14	Reserved — RO. Hardwired to 00h
13:6	<b>SMI on PortOwner Enable</b> — R/W. 0 = Disable. 1 = Enable. When any of these bits are 1 and the corresponding SMI on PortOwner bits are 1, then the host controller will issue an SMI. Unused ports should have their corresponding bits cleared.
5	<b>SMI on PMSCR Enable</b> — R/W. 0 = Disable. 1 = Enable. When this bit is 1 and SMI on PMSCR is 1, then the host controller will issue an SMI.
4	<b>SMI on Async Enable</b> — R/W. 0 = Disable. 1 = Enable. When this bit is 1 and SMI on Async is 1, then the host controller will issue an SMI









## 15.2 Memory-Mapped I/O Registers

The EHCI memory-mapped I/O space is composed of two sets of registers: Capability Registers and Operational Registers.

**Note:** The ICH8 EHCI controller will not accept memory transactions (neither reads nor writes) as a target that are locked transactions. The locked transactions should not be forwarded to PCI as the address space is known to be allocated to USB.

**Note:** When the EHCI function is in the D3 PCI power state, accesses to the USB 2.0 memory range are ignored and result a master abort. Similarly, if the Memory Space Enable (MSE) bit (D29:F7, D26:F7:04h, bit 1) is not set in the Command register in configuration space, the memory range will not be decoded by the ICH8 enhanced host controller (EHC). If the MSE bit is not set, then the ICH8 must default to allowing any memory accesses for the range specified in the BAR to go to PCI. This is because the range may not be valid and, therefore, the cycle must be made available to any other targets that may be currently using that range.

### 15.2.1 Host Controller Capability Registers

These registers specify the limits, restrictions and capabilities of the host controller implementation. Within the host controller capability registers, only the structural parameters register is writable. These registers are implemented in the suspend well and is only reset by the standard suspend-well hardware reset, not by HCRESET or the D3-to-D0 reset.

**Note:** Note that the EHCI controller does not support as a target memory transactions that are locked transactions. Attempting to access the EHCI controller Memory-Mapped I/O space using locked memory transactions will result in undefined behavior.

**Note:** Note that when the USB2 function is in the D3 PCI power state, accesses to the USB2 memory range are ignored and will result in a master abort. Similarly, if the Memory Space Enable (MSE) bit is not set in the Command register in configuration space, the memory range will not be decoded by the Enhanced Host Controller (EHC). If the MSE bit is not set, then the EHC will not claim any memory accesses for the range specified in the BAR.

**Table 134. Enhanced Host Controller Capability Registers**

MEM_BASE + Offset	Mnemonic	Register	Default	Type
00h	CAPLENGTH	Capabilities Registers Length	20h	RO
02h–03h	HCVERSION	Host Controller Interface Version Number	0100h	RO
04h–07h	HCCPARAMS	Host Controller Structural Parameters	00104208h	R/W (special), RO
08h–0Bh	HCCPARAMS	Host Controller Capability Parameters	00006871h	RO

**NOTE:** “Read/Write Special” means that the register is normally read-only, but may be written when the WRT\_RDONLY bit is set. Because these registers are expected to be programmed by BIOS during initialization, their contents must not get modified by HCRESET or D3-to-D0 internal reset.



### 15.2.1.1 CAPLENGTH—Capability Registers Length

Offset: MEM\_BASE + 00h      Attribute: RO  
Default Value: 20h      Size: 8 bits

Bit	Description
7:0	Capability Register Length Value — RO. This register is used as an offset to add to the Memory Base Register (D29:F7, D26:F7:10h) to find the beginning of the Operational Register Space. This field is hardwired to 20h indicating that the Operation Registers begin at offset 20h.

### 15.2.1.2 HCIVERSION—Host Controller Interface Version Number

Offset: MEM\_BASE + 02h–03h      Attribute: RO  
Default Value: 0100h      Size: 16 bits

Bit	Description
15:0	Host Controller Interface Version Number — RO. This is a two-byte register containing a BCD encoding of the version number of interface that this host controller interface conforms.



### 15.2.1.3 HCSPARAMS—Host Controller Structural Parameters

Offset: MEM\_BASE + 04h–07h      Attribute: R/W (special), RO  
 Default Value: 00103206h (D29:F7)      Size: 32 bits  
 00102204h (D26:F7)

**Note:** This register is reset by a suspend well reset and not a D3-to-D0 reset or HCRESET.

Bit	Description
31:24	Reserved — RO. Default=0h.
23:20	Debug Port Number (DP_N) — RO (special). Hardwired to 1h indicating that the Debug Port is on the lowest numbered port on the EHCI.
19:16	Reserved
15:12	<b>Number of Companion Controllers (N_CC)</b> — R/W (special). This field indicates the number of companion controllers associated with this USB EHCI host controller. A 0 in this field indicates there are no companion host controllers. Port-ownership hand-off is not supported. Only high-speed devices are supported on the host controller root ports. A value of 1 or more in this field indicates there are companion USB UHCI host controller(s). Port-ownership hand-offs are supported. High, Full- and Low-speed devices are supported on the host controller root ports. The ICH8 allows the default value of 3h (D29) or 2 (D26) to be over-written by BIOS. When removing classic controllers, they must be disabled in the following order: Function 2, Function 1, and Function 0, which correspond to ports 5:4, 3:2, and 1:0, respectively for Device 29. For Device 26 the following order is Function 1 then Function 0, which correspond to ports 9:8 and 7:6, respectively.
11:8	<b>Number of Ports per Companion Controller (N_PCC)</b> — RO. Hardwired to 2h. This field indicates the number of ports supported per companion host controller. It is used to indicate the port routing configuration to system software.
7:4	Reserved. These bits are reserved and default to 0.
3:0	<b>N_PORTS</b> — R/W (special). This field specifies the number of physical downstream ports implemented on this host controller. The value of this field determines how many port registers are addressable in the Operational Register Space. Valid values are in the range of 1h to Fh. The ICH8 reports 6h for D29 and 4h for D26 by default. However, software may write a value less than the default for some platform configurations. A 0 in this field is undefined.

**NOTE:** This register is writable when the WRT\_RDONLY bit is set.



### 15.2.1.4 HCCPARAMS—Host Controller Capability Parameters Register

Offset: MEM\_BASE + 08h–0Bh Attribute: RO  
 Default Value: 00006871h Size: 32 bits

Bit	Description
31:16	Reserved
15:8	EHCI Extended Capabilities Pointer (EECP) — RO. This field is hardwired to 68h, indicating that the EHCI capabilities list exists and begins at offset 68h in the PCI configuration space.
7:4	Isochronous Scheduling Threshold — RO. This field indicates, relative to the current position of the executing host controller, where software can reliably update the isochronous schedule. When bit 7 is 0, the value of the least significant 3 bits indicates the number of micro-frames a host controller hold a set of isochronous data structures (one or more) before flushing the state. When bit 7 is a 1, then host software assumes the host controller may cache an isochronous data structure for an entire frame. Refer to the EHCI specification for details on how software uses this information for scheduling isochronous transfers. This field is hardwired to 7h.
3	Reserved. These bits are reserved and should be set to 0.
2	Asynchronous Schedule Park Capability — RO. This bit is hardwired to 0 indicating that the host controller does not support this optional feature
1	Programmable Frame List Flag — RO. 0 = System software must use a frame list length of 1024 elements with this host controller. The USB2.0_CMD register (D29:F7, D26:F7:CAPLENGTH + 20h, bits 3:2) <i>Frame List Size</i> field is a read-only register and must be set to 0. 1 = System software can specify and use a smaller frame list and configure the host controller via the USB2.0_CMD register <i>Frame List Size</i> field. The frame list must always be aligned on a 4K page boundary. This requirement ensures that the frame list is always physically contiguous.
0	64-bit Addressing Capability — RO. This field documents the addressing range capability of this implementation. The value of this field determines whether software should use the 32-bit or 64-bit data structures. Values for this field have the following interpretation: 0 = Data structures using 32-bit address memory pointers 1 = Data structures using 64-bit address memory pointers This bit is hardwired to 1.  <b>NOTE:</b> ICH8 only implements 44 bits of addressing. Bits 63:44 will always be 0.



## 15.2.2 Host Controller Operational Registers

This section defines the enhanced host controller operational registers. These registers are located after the capabilities registers. The operational register base must be dword-aligned and is calculated by adding the value in the first capabilities register (CAPLENGTH) to the base address of the enhanced host controller register address space (MEM\_BASE). Since CAPLENGTH is always 20h, Table 135 already accounts for this offset. All registers are 32 bits in length.

**Table 135. Enhanced Host Controller Operational Register Address Map**

MEM_BASE + Offset	Mnemonic	Register Name	Default	Special Notes	Type
20h–23h	USB2.0_CMD	USB 2.0 Command	00080000h		R/W, RO
24h–27h	USB2.0_STS	USB 2.0 Status	00001000h		R/WC, RO
28h–2Bh	USB2.0_INTR	USB 2.0 Interrupt Enable	00000000h		R/W
2Ch–2Fh	FRINDEX	USB 2.0 Frame Index	00000000h		R/W,
30h–33h	CTRLDSSEGM ENT	Control Data Structure Segment	00000000h		R/W, RO
34h–37h	PERODICLIST BASE	Period Frame List Base Address	00000000h		R/W
38h–3Bh	ASYNCLISTADR	Current Asynchronous List Address	00000000h		R/W
3Ch–5Fh	—	Reserved	0h		RO
60h–63h	CONFIGFLAG	Configure Flag	00000000h	Suspend	R/W
64h–67h	PORT0SC	Port 0 Status and Control	00003000h	Suspend	R/W, R/WC, RO
68h–6Bh	PORT1SC	Port 1 Status and Control	00003000h	Suspend	R/W, R/WC, RO
6Ch–6Fh	PORT2SC	Port 2 Status and Control	00003000h	Suspend	R/W, R/WC, RO
70h–73h	PORT3SC	Port 3 Status and Control	00003000h	Suspend	R/W, R/WC, RO
74h–77h D29 Only	PORT4SC	Port 4 Status and Control	00003000h	Suspend	R/W, R/WC, RO
78h–7Bh D29 Only	PORT5SC	Port 5 Status and Control	00003000h	Suspend	R/W, R/WC, RO
7Ch–9Fh	—	Reserved	Undefined		RO
A0h–B3h	—	Debug Port Registers	Undefined		See register description
B4h–3FFh	—	Reserved	Undefined		RO

**Note:** Software must read and write these registers using only dword accesses. These registers are divided into two sets. The first set at offsets MEM\_BASE + 00:3Bh are implemented in the core power well. Unless otherwise noted, the core well registers are reset by the assertion of any of the following:

- Core well hardware reset
- HCRESET
- D3-to-D0 reset



The second set at offsets MEM\_BASE + 60h to the end of the implemented register space are implemented in the Suspend power well. Unless otherwise noted, the suspend well registers are reset by the assertion of either of the following:

- Suspend well hardware reset
- HCRESET

15.2.2.1 USB2.0\_CMD—USB 2.0 Command Register

Offset: MEM\_BASE + 20–23h Attribute: R/W, RO  
 Default Value: 00080000h Size: 32 bits

Bit	Description																		
31:24	Reserved. These bits are reserved and should be set to 0 when writing this register.																		
23:16	<p><b>Interrupt Threshold Control</b> — R/W. System software uses this field to select the maximum rate at which the host controller will issue interrupts. The only valid values are defined below. If software writes an invalid value to this register, the results are undefined.</p> <table border="1"> <thead> <tr> <th>Value</th> <th>Maximum Interrupt Interval</th> </tr> </thead> <tbody> <tr> <td>00h</td> <td>Reserved</td> </tr> <tr> <td>01h</td> <td>1 micro-frame</td> </tr> <tr> <td>02h</td> <td>2 micro-frames</td> </tr> <tr> <td>04h</td> <td>4 micro-frames</td> </tr> <tr> <td>08h</td> <td>8 micro-frames (default, equates to 1 ms)</td> </tr> <tr> <td>10h</td> <td>16 micro-frames (2 ms)</td> </tr> <tr> <td>20h</td> <td>32 micro-frames (4 ms)</td> </tr> <tr> <td>40h</td> <td>64 micro-frames (8 ms)</td> </tr> </tbody> </table>	Value	Maximum Interrupt Interval	00h	Reserved	01h	1 micro-frame	02h	2 micro-frames	04h	4 micro-frames	08h	8 micro-frames (default, equates to 1 ms)	10h	16 micro-frames (2 ms)	20h	32 micro-frames (4 ms)	40h	64 micro-frames (8 ms)
Value	Maximum Interrupt Interval																		
00h	Reserved																		
01h	1 micro-frame																		
02h	2 micro-frames																		
04h	4 micro-frames																		
08h	8 micro-frames (default, equates to 1 ms)																		
10h	16 micro-frames (2 ms)																		
20h	32 micro-frames (4 ms)																		
40h	64 micro-frames (8 ms)																		
15:8	Reserved. These bits are reserved and should be set to 0 when writing this register.																		
11:8	Unimplemented Asynchronous Park Mode Bits. Hardwired to 000b indicating the host controller does not support this optional feature.																		
7	Light Host Controller Reset — RO. Hardwired to 0. The ICH8 does not implement this optional reset.																		
6	<p><b>Interrupt on Async Advance Doorbell</b> — R/W. This bit is used as a doorbell by software to tell the host controller to issue an interrupt the next time it advances asynchronous schedule.</p> <p>0 = The host controller sets this bit to a 0 after it has set the Interrupt on Async Advance status bit (D29:F7, D26:F7:CAPLENGTH + 24h, bit 5) in the USB2.0_STS register to a 1.</p> <p>1 = Software must write a 1 to this bit to ring the doorbell. When the host controller has evicted all appropriate cached schedule state, it sets the Interrupt on Async Advance status bit in the USB2.0_STS register. If the <i>Interrupt on Async Advance Enable</i> bit in the USB2.0_INTR register (D29:F7, D26:F7:CAPLENGTH + 28h, bit 5) is a 1 then the host controller will assert an interrupt at the next interrupt threshold. See the EHCI specification for operational details.</p> <p><b>NOTE:</b> Software should not write a 1 to this bit when the asynchronous schedule is inactive. Doing so will yield undefined results.</p>																		
5	<p><b>Asynchronous Schedule Enable</b> — R/W. Default 0b. This bit controls whether the host controller skips processing the Asynchronous Schedule.</p> <p>0 = Do not process the Asynchronous Schedule</p> <p>1 = Use the ASYNCLISTADDR register to access the Asynchronous Schedule.</p>																		





Bit	Description															
4	<p><b>Periodic Schedule Enable</b> — R/W. Default 0b. This bit controls whether the host controller skips processing the Periodic Schedule.</p> <p>0 = Do not process the Periodic Schedule                      1 = Use the PERIODICLISTBASE register to access the Periodic Schedule.</p>															
3:2	<p><b>Frame List Size</b> — RO. The ICH8 hardwires this field to 00b because it only supports the 1024-element frame list size.</p>															
1	<p><b>Host Controller Reset (HCRESET)</b> — R/W. This control bit used by software to reset the host controller. The effects of this on root hub registers are similar to a Chip Hardware Reset (i.e., RSMRST# assertion and PWROK deassertion on the ICH8).</p> <p>When software writes a 1 to this bit, the host controller resets its internal pipelines, timers, counters, state machines, etc. to their initial value. Any transaction currently in progress on USB is immediately terminated. A USB reset is not driven on downstream ports.</p> <p><b>NOTE:</b> PCI configuration registers and Host controller capability registers are not effected by this reset.</p> <p>All operational registers, including port registers and port state machines are set to their initial values. Port ownership reverts to the companion host controller(s), with the side effects described in the EHCI spec. Software must re-initialize the host controller in order to return the host controller to an operational state.</p> <p>This bit is set to 0 by the host controller when the reset process is complete. Software cannot terminate the reset process early by writing a 0 to this register.</p> <p>Software should not set this bit to a 1 when the HCHalted bit (D29:F7, D26:F7:CAPLENGTH + 24h, bit 12) in the USB2.0_STS register is a 0. Attempting to reset an actively running host controller will result in undefined behavior. This reset me be used to leave EHCI port test modes.</p>															
0	<p><b>Run/Stop (RS)</b> — R/W.</p> <p>0 = Stop (default)                      1 = Run. When set to a 1, the Host controller proceeds with execution of the schedule. The Host controller continues execution as long as this bit is set. When this bit is set to 0, the Host controller completes the current transaction on the USB and then halts. The HCHalted bit in the USB2.0_STS register indicates when the Host controller has finished the transaction and has entered the stopped state.</p> <p>Software should not write a 1 to this field unless the host controller is in the Halted state (i.e., HCHalted in the USBSTS register is a 1). The Halted bit is cleared immediately when the Run bit is set.</p> <p>The following table explains how the different combinations of Run and Halted should be interpreted:</p> <table border="1" data-bbox="487 1486 1258 1644"> <thead> <tr> <th>Run/Stop</th> <th>Halted</th> <th>Interpretation</th> </tr> </thead> <tbody> <tr> <td>0b</td> <td>0b</td> <td>In the process of halting</td> </tr> <tr> <td>0b</td> <td>1b</td> <td>Halted</td> </tr> <tr> <td>1b</td> <td>0b</td> <td>Running</td> </tr> <tr> <td>1b</td> <td>1b</td> <td>Invalid - the HCHalted bit clears immediately</td> </tr> </tbody> </table> <p>Memory read cycles initiated by the EHC that receive any status other than Successful will result in this bit being cleared.</p>	Run/Stop	Halted	Interpretation	0b	0b	In the process of halting	0b	1b	Halted	1b	0b	Running	1b	1b	Invalid - the HCHalted bit clears immediately
Run/Stop	Halted	Interpretation														
0b	0b	In the process of halting														
0b	1b	Halted														
1b	0b	Running														
1b	1b	Invalid - the HCHalted bit clears immediately														

**NOTE:** The Command Register indicates the command to be executed by the serial bus host controller. Writing to the register causes a command to be executed.



### 15.2.2.2 USB2.0\_STS—USB 2.0 Status Register

Offset: MEM\_BASE + 24h–27h      Attribute: R/WC, RO  
 Default Value: 00001000h      Size: 32 bits

This register indicates pending interrupts and various states of the Host controller. The status resulting from a transaction on the serial bus is not indicated in this register. See the Interrupts description in section 4 of the EHCI specification for additional information concerning USB 2.0 interrupt conditions.

**Note:** For the writable bits, software must write a 1 to clear bits that are set. Writing a 0 has no effect.

Bit	Description
31:16	Reserved. These bits are reserved and should be set to 0 when writing this register.
15	<p><b>Asynchronous Schedule Status</b> — RO. This bit reports the current real status of the Asynchronous Schedule.</p> <p>0 = Status of the Asynchronous Schedule is disabled. (Default)            1 = Status of the Asynchronous Schedule is enabled.</p> <p><b>NOTE:</b> The Host controller is not required to <i>immediately</i> disable or enable the Asynchronous Schedule when software transitions the <i>Asynchronous Schedule Enable</i> bit (D29:F7, D26:F7:CAPLENGTH + 20h, bit 5) in the USB2.0_CMD register. When this bit and the <i>Asynchronous Schedule Enable</i> bit are the same value, the Asynchronous Schedule is either enabled (1) or disabled (0).</p>
14	<p><b>Periodic Schedule Status</b> — RO. This bit reports the current real status of the Periodic Schedule.</p> <p>0 = Status of the Periodic Schedule is disabled. (Default)            1 = Status of the Periodic Schedule is enabled.</p> <p><b>NOTE:</b> The Host controller is not required to <i>immediately</i> disable or enable the Periodic Schedule when software transitions the <i>Periodic Schedule Enable</i> bit (D29:F7, D26:F7:CAPLENGTH + 20h, bit 4) in the USB2.0_CMD register. When this bit and the <i>Periodic Schedule Enable</i> bit are the same value, the Periodic Schedule is either enabled (1) or disabled (0).</p>
13	<p><b>Reclamation</b> — RO. 0=Default. This read-only status bit is used to detect an empty asynchronous schedule. The operational model and valid transitions for this bit are described in Section 4 of the EHCI Specification.</p>
12	<p><b>HCHalted</b> — RO.</p> <p>0 = This bit is a 0 when the Run/Stop bit is a 1.            1 = The Host controller sets this bit to 1 after it has stopped executing as a result of the Run/Stop bit being set to 0, either by software or by the Host controller hardware (e.g., internal error). (Default)</p>
11:6	Reserved
5	<p><b>Interrupt on Async Advance</b> — R/WC. 0=Default. System software can force the host controller to issue an interrupt the next time the host controller advances the asynchronous schedule by writing a 1 to the <i>Interrupt on Async Advance Doorbell</i> bit (D29:F7, D26:F7:CAPLENGTH + 20h, bit 6) in the USB2.0_CMD register. This bit indicates the assertion of that interrupt source.</p>



Bit	Description
4	<p><b>Host System Error</b> — R/WC.</p> <p>0 = No serious error occurred during a host system access involving the Host controller module</p> <p>1 = The Host controller sets this bit to 1 when a serious error occurs during a host system access involving the Host controller module. A hardware interrupt is generated to the system. Memory read cycles initiated by the EHC that receive any status other than Successful will result in this bit being set.</p> <p>When this error occurs, the Host controller clears the Run/Stop bit in the USB2.0_CMDregister (D29:F7, D26:F7:CAPLENGTH + 20h, bit 0) to prevent further execution of the scheduled TDs. A hardware interrupt is generated to the system (if enabled in the Interrupt Enable Register).</p>
3	<p><b>Frame List Rollover</b> — R/WC.</p> <p>0 = No <i>Frame List Index</i> rollover from its maximum value to 0.</p> <p>1 = The Host controller sets this bit to a 1 when the <i>Frame List Index</i> (see Section) rolls over from its maximum value to 0. Since the ICH8 only supports the 1024-entry Frame List Size, the <i>Frame List Index</i> rolls over every time FRNUM13 toggles.</p>
2	<p><b>Port Change Detect</b> — R/WC. This bit is allowed to be maintained in the Auxiliary power well. Alternatively, it is also acceptable that on a D3 to D0 transition of the EHCI HC device, this bit is loaded with the OR of all of the PORTSC change bits (including: Force port resume, overcurrent change, enable/disable change and connect status change). Regardless of the implementation, when this bit is readable (i.e., in the D0 state), it must provide a valid view of the Port Status registers.</p> <p>0 = No change bit transition from a 0 to 1 or No Force Port Resume bit transition from 0 to 1 as a result of a J-K transition detected on a suspended port.</p> <p>1 = The Host controller sets this bit to 1 when any port for which the <i>Port Owner</i> bit is set to 0 has a change bit transition from a 0 to 1 or a Force Port Resume bit transition from 0 to 1 as a result of a J-K transition detected on a suspended port.</p>
1	<p><b>USB Error Interrupt (USBERRINT)</b> — R/WC.</p> <p>0 = No error condition.</p> <p>1 = The Host controller sets this bit to 1 when completion of a USB transaction results in an error condition (e.g., error counter underflow). If the TD on which the error interrupt occurred also had its IOC bit set, both this bit and Bit 0 are set. See the EHCI specification for a list of the USB errors that will result in this interrupt being asserted.</p>
0	<p><b>USB Interrupt (USBINT)</b> — R/WC.</p> <p>0 = No completion of a USB transaction whose Transfer Descriptor had its IOC bit set. No short packet is detected.</p> <p>1 = The Host controller sets this bit to 1 when the cause of an interrupt is a completion of a USB transaction whose Transfer Descriptor had its IOC bit set. The Host controller also sets this bit to 1 when a short packet is detected (actual number of bytes received was less than the expected number of bytes).</p>



### 15.2.2.3 USB2.0\_INTR—USB 2.0 Interrupt Enable Register

Offset: MEM\_BASE + 28h–2Bh      Attribute: R/W  
 Default Value: 00000000h      Size: 32 bits

This register enables and disables reporting of the corresponding interrupt to the software. When a bit is set and the corresponding interrupt is active, an interrupt is generated to the host. Interrupt sources that are disabled in this register still appear in the USB2.0\_STS Register to allow the software to poll for events. Each interrupt enable bit description indicates whether it is dependent on the interrupt threshold mechanism (see Section 4 of the EHCI specification), or not.

Bit	Description
31:6	Reserved. These bits are reserved and should be 0 when writing this register.
5	<b>Interrupt on Async Advance Enable</b> — R/W. 0 = Disable. 1 = Enable. When this bit is a 1, and the Interrupt on Async Advance bit (D29:F7, D26:F7:CAPLENGTH + 24h, bit 5) in the USB2.0_STS register is a 1, the host controller will issue an interrupt at the next interrupt threshold. The interrupt is acknowledged by software clearing the Interrupt on Async Advance bit.
4	<b>Host System Error Enable</b> — R/W. 0 = Disable. 1 = Enable. When this bit is a 1, and the Host System Error Status bit (D29:F7, D26:F7:CAPLENGTH + 24h, bit 4) in the USB2.0_STS register is a 1, the host controller will issue an interrupt. The interrupt is acknowledged by software clearing the Host System Error bit.
3	<b>Frame List Rollover Enable</b> — R/W. 0 = Disable. 1 = Enable. When this bit is a 1, and the Frame List Rollover bit (D29:F7, D26:F7:CAPLENGTH + 24h, bit 3) in the USB2.0_STS register is a 1, the host controller will issue an interrupt. The interrupt is acknowledged by software clearing the Frame List Rollover bit.
2	<b>Port Change Interrupt Enable</b> — R/W. 0 = Disable. 1 = Enable. When this bit is a 1, and the Port Change Detect bit (D29:F7, D26:F7:CAPLENGTH + 24h, bit 2) in the USB2.0_STS register is a 1, the host controller will issue an interrupt. The interrupt is acknowledged by software clearing the Port Change Detect bit.
1	<b>USB Error Interrupt Enable</b> — R/W. 0 = Disable. 1 = Enable. When this bit is a 1, and the USBERRINT bit (D29:F7, D26:F7:CAPLENGTH + 24h, bit 1) in the USB2.0_STS register is a 1, the host controller will issue an interrupt at the next interrupt threshold. The interrupt is acknowledged by software by clearing the USBERRINT bit in the USB2.0_STS register.
0	<b>USB Interrupt Enable</b> — R/W. 0 = Disable. 1 = Enable. When this bit is a 1, and the USBINT bit (D29:F7, D26:F7:CAPLENGTH + 24h, bit 0) in the USB2.0_STS register is a 1, the host controller will issue an interrupt at the next interrupt threshold. The interrupt is acknowledged by software by clearing the USBINT bit in the USB2.0_STS register.



### 15.2.2.4 FRINDEX—Frame Index Register

Offset: MEM\_BASE + 2Ch–2Fh Attribute: R/W  
 Default Value: 00000000h Size: 32 bits

The SOF frame number value for the bus SOF token is derived or alternatively managed from this register. Refer to Section 4 of the EHCI specification for a detailed explanation of the SOF value management requirements on the host controller. The value of FRINDEX must be within 125 μs (1 micro-frame) ahead of the SOF token value. The SOF value may be implemented as an 11-bit shadow register. For this discussion, this shadow register is 11 bits and is named SOFV. SOFV updates every 8 micro-frames. (1 millisecond). An example implementation to achieve this behavior is to increment SOFV each time the FRINDEX[2:0] increments from 0 to 1.

Software must use the value of FRINDEX to derive the current micro-frame number, both for high-speed isochronous scheduling purposes and to provide the **get** micro-frame number function required to client drivers. Therefore, the value of FRINDEX and the value of SOFV must be kept consistent if chip is reset or software writes to FRINDEX. Writes to FRINDEX must also **write-through** FRINDEX[13:3] to SOFV[10:0]. In order to keep the update as simple as possible, software should never write a FRINDEX value where the three least significant bits are 111b or 000b.

**Note:** This register is used by the host controller to index into the periodic frame list. The register updates every 125 microseconds (once each micro-frame). Bits [12:3] are used to select a particular entry in the Periodic Frame List during periodic schedule execution. The number of bits used for the index is fixed at 10 for the ICH8 since it only supports 1024-entry frame lists. This register must be written as a dword. Word and byte writes produce undefined results. This register cannot be written unless the Host controller is in the Halted state as indicated by the *HCHalted* bit (D29:F7, D26:F7:CAPLENGTH + 24h, bit 12). A write to this register while the Run/Stop bit (D29:F7, D26:F7:CAPLENGTH + 20h, bit 0) is set to a 1 (USB2.0\_CMD register) produces undefined results. Writes to this register also effect the SOF value. See Section 4 of the EHCI specification for details.

Bit	Description
31:14	Reserved
13:0	<b>Frame List Current Index/Frame Number</b> — R/W. The value in this register increments at the end of each time frame (e.g., micro-frame). Bits [12:3] are used for the Frame List current index. This means that each location of the frame list is accessed 8 times (frames or micro-frames) before moving to the next index.



### 15.2.2.5 CTRLDSSEGMENT—Control Data Structure Segment Register

Offset: MEM\_BASE + 30h–33h Attribute: R/W, RO  
Default Value: 00000000h Size: 32 bits

This 32-bit register corresponds to the most significant address bits [63:32] for all EHCI data structures. Since the ICH8 hardwires the 64-bit Addressing Capability field in HCCPARAMS to 1, then this register is used with the link pointers to construct 64-bit addresses to EHCI control data structures. This register is concatenated with the link pointer from either the PERIODICLISTBASE, ASYNCLISTADDR, or any control data structure link field to construct a 64-bit address. This register allows the host software to locate all control data structures within the same 4 GB memory segment.

Bit	Description
31:12	Upper Address[63:44] — RO. Hardwired to 0s. The ICH8 EHC is only capable of generating addresses up to 16 terabytes (44 bits of address).
11:0	Upper Address[43:32] — R/W. This 12-bit field corresponds to address bits 43:32 when forming a control data structure address.

### 15.2.2.6 PERIODICLISTBASE—Periodic Frame List Base Address Register

Offset: MEM\_BASE + 34h–37h Attribute: R/W  
Default Value: 00000000h Size: 32 bits

This 32-bit register contains the beginning address of the Periodic Frame List in the system memory. Since the ICH8 host controller operates in 64-bit mode (as indicated by the 1 in the 64-bit Addressing Capability field in the HCCSPARAMS register) (offset 08h, bit 0), then the most significant 32 bits of every control data structure address comes from the CTRLDSSEGMENT register. HCD loads this register prior to starting the schedule execution by the host controller. The memory structure referenced by this physical memory pointer is assumed to be 4-Kbyte aligned. The contents of this register are combined with the Frame Index Register (FRINDEX) to enable the Host controller to step through the Periodic Frame List in sequence.

Bit	Description
31:12	<b>Base Address (Low)</b> — R/W. These bits correspond to memory address signals [31:12], respectively.
11:0	Reserved. Must be written as 0s. During runtime, the value of these bits are undefined.



### 15.2.2.7 ASYNCLI STADDR—Current Asynchronous List Address Register

Offset: MEM\_BASE + 38h–3Bh Attribute: R/W  
 Default Value: 00000000h Size: 32 bits

This 32-bit register contains the address of the next asynchronous queue head to be executed. Since the ICH8 host controller operates in 64-bit mode (as indicated by a 1 in 64-bit Addressing Capability field in the HCCPARAMS register) (offset 08h, bit 0), then the most significant 32 bits of every control data structure address comes from the CTRLDSSEGMENT register (offset 08h). Bits [4:0] of this register cannot be modified by system software and will always return 0's when read. The memory structure referenced by this physical memory pointer is assumed to be 32-byte aligned.

Bit	Description
31:5	<b>Link Pointer Low (LPL)</b> — R/W. These bits correspond to memory address signals [31:5], respectively. This field may only reference a Queue Head (QH).
4:0	Reserved. These bits are reserved and their value has no effect on operation.

### 15.2.2.8 CONFIGFLAG—Configure Flag Register

Offset: MEM\_BASE + 60h–63h Attribute: R/W  
 Default Value: 00000000h Size: 32 bits

This register is in the suspend power well. It is only reset by hardware when the suspend power is initially applied or in response to a host controller reset.

Bit	Description
31:1	Reserved. Read from this field will always return 0.
0	<b>Configure Flag (CF)</b> — R/W. Host software sets this bit as the last action in its process of configuring the Host controller. This bit controls the default port-routing control logic. Bit values and side-effects are listed below. See section 4 of the EHCI spec for operation details. 0 = Port routing control logic default-routes each port to the UHCIs (default). 1 = Port routing control logic default-routes all ports to this host controller.



### 15.2.2.9 PORTSC—Port N Status and Control Register

Offset: Port 0, Port 6: MEM\_BASE + 64h–67h  
 Port 1, Port 7: MEM\_BASE + 68–6Bh  
 Port 2, Port 8: MEM\_BASE + 6C–6Fh  
 Port 3, Port 9: MEM\_BASE + 70–73h  
 Port 4: MEM\_BASE + 74–77h (Device 29 Only)  
 Port 5: MEM\_BASE + 78–7Bh (Device 29 Only)

Attribute: R/W, R/WC, RO  
 Default Value: 00003000h Size: 32 bits

A host controller must implement one or more port registers. Software uses the N\_Port information from the Structural Parameters Register to determine how many ports need to be serviced. All ports have the structure defined below. Software must not write to unreported Port Status and Control Registers.

This register is in the suspend power well. It is only reset by hardware when the suspend power is initially applied or in response to a host controller reset. The initial conditions of a port are:

- No device connected
- Port disabled.

When a device is attached, the port state transitions to the attached state and system software will process this as with any status change notification. Refer to Section 4 of the EHCI specification for operational requirements for how change events interact with port suspend mode.

Bit	Description
31:23	Reserved. These bits are reserved for future use and will return a value of 0's when read.
22	<b>Wake on Overcurrent Enable (WKOC_E)</b> — R/W. 0 = Disable. (Default) 1 = Enable. Writing this bit to a 1 enables the setting of the PME Status bit in the Power Management Control/Status Register (offset 54, bit 15) when the overcurrent Active bit (bit 4 of this register) is set.
21	<b>Wake on Disconnect Enable (WKDSCNNT_E)</b> — R/W. 0 = Disable. (Default) 1 = Enable. Writing this bit to a 1 enables the setting of the PME Status bit in the Power Management Control/Status Register (offset 54, bit 15) when the Current Connect Status changes from connected to disconnected (i.e., bit 0 of this register changes from 1 to 0).
20	<b>Wake on Connect Enable (WKCNNNT_E)</b> — R/W. 0 = Disable. (Default) 1 = Enable. Writing this bit to a 1 enables the setting of the PME Status bit in the Power Management Control/Status Register (offset 54, bit 15) when the Current Connect Status changes from disconnected to connected (i.e., bit 0 of this register changes from 0 to 1).





Bit	Description														
19:16	<p><b>Port Test Control</b> — R/W. When this field is 0s, the port is NOT operating in a test mode. A non-zero value indicates that it is operating in test mode and the specific test mode is indicated by the specific value. The encoding of the test mode bits are (0110b – 1111b are reserved):</p> <table border="0"> <thead> <tr> <th data-bbox="505 449 581 470">Value</th> <th data-bbox="623 449 964 470">Maximum Interrupt Interval</th> </tr> </thead> <tbody> <tr> <td data-bbox="505 480 581 501">0000b</td> <td data-bbox="623 480 964 501">Test mode not enabled (default)</td> </tr> <tr> <td data-bbox="505 512 581 533">0001b</td> <td data-bbox="721 512 867 533">Test J_STATE</td> </tr> <tr> <td data-bbox="505 543 581 564">0010b</td> <td data-bbox="721 543 867 564">Test K_STATE</td> </tr> <tr> <td data-bbox="505 575 581 596">0011b</td> <td data-bbox="721 575 867 596">Test SEO_NAK</td> </tr> <tr> <td data-bbox="505 606 581 627">0100b</td> <td data-bbox="721 606 850 627">Test Packet</td> </tr> <tr> <td data-bbox="505 638 581 659">0101b</td> <td data-bbox="704 638 883 659">FORCE_ENABLE</td> </tr> </tbody> </table> <p>Refer to USB Specification Revision 2.0, Chapter 7 for details on each test mode.</p>	Value	Maximum Interrupt Interval	0000b	Test mode not enabled (default)	0001b	Test J_STATE	0010b	Test K_STATE	0011b	Test SEO_NAK	0100b	Test Packet	0101b	FORCE_ENABLE
Value	Maximum Interrupt Interval														
0000b	Test mode not enabled (default)														
0001b	Test J_STATE														
0010b	Test K_STATE														
0011b	Test SEO_NAK														
0100b	Test Packet														
0101b	FORCE_ENABLE														
15:14	Reserved — R/W. Should be written to =00b.														
13	<p><b>Port Owner</b> — R/W. Default = 1b. This bit unconditionally goes to a 0 when the Configured Flag bit in the USB2.0_CMD register makes a 0 to 1 transition. System software uses this field to release ownership of the port to a selected host controller (in the event that the attached device is not a high-speed device). Software writes a 1 to this bit when the attached device is not a high-speed device. A 1 in this bit means that a companion host controller owns and controls the port. See Section 4 of the EHCI Specification for operational details.</p>														
12	<p><b>Port Power (PP)</b> — RO. Read-only with a value of 1. This indicates that the port does have power.</p>														
11:10	<p><b>Line Status</b>— RO. These bits reflect the current logical levels of the D+ (bit 11) and D– (bit 10) signal lines. These bits are used for detection of low-speed USB devices prior to the port reset and enable sequence. This field is valid only when the port enable bit is 0 and the current connect status bit is set to a 1.</p> <p>00 = SEO          10 = J-state          01 = K-state          11 = Undefined</p>														
9	Reserved. This bit will return a 0 when read.														



Bit	Description												
8	<p><b>Port Reset</b> — R/W. Default = 0. When software writes a 1 to this bit (from a 0), the bus reset sequence as defined in the USB Specification, Revision 2.0 is started. Software writes a 0 to this bit to terminate the bus reset sequence. Software must keep this bit at a 1 long enough to assure the reset sequence completes as specified in the USB Specification, Revision 2.0.</p> <p>1 = Port is in Reset. 0 = Port is not in Reset.</p> <p><b>NOTE:</b> When software writes a 0 to this bit, there may be a delay before the bit status changes to a 0. The bit status will not read as a 0 until after the reset has completed. If the port is in high-speed mode after reset is complete, the host controller will automatically enable this port (e.g., set the <i>Port Enable</i> bit to a 1). A host controller must terminate the reset and stabilize the state of the port within 2 milliseconds of software transitioning this bit from 0 to 1.</p> <p>For example: if the port detects that the attached device is high-speed during reset, then the host controller must have the port in the enabled state within 2 ms of software writing this bit to a 0. The <i>HCHalted</i> bit (D29:F7, D26:F7:CAPLENGTH + 24h, bit 12) in the USB2.0_STS register should be a 0 before software attempts to use this bit. The host controller may hold Port Reset asserted to a 1 when the <i>HCHalted</i> bit is a 1. This bit is 0 if Port Power is 0</p> <p><b>NOTE:</b> System software should not attempt to reset a port if the <i>HCHalted</i> bit in the USB2.0_STS register is a 1. Doing so will result in undefined behavior.</p>												
7	<p><b>Suspend</b> — R/W.</p> <p>0 = Port not in suspend state.(Default) 1 = Port in suspend state.</p> <p>Port Enabled Bit and Suspend bit of this register define the port states as follows:</p> <table border="1" data-bbox="511 1119 1104 1245"> <thead> <tr> <th>Port Enabled</th> <th>Suspend</th> <th>Port State</th> </tr> </thead> <tbody> <tr> <td>0</td> <td>X</td> <td>Disabled</td> </tr> <tr> <td>1</td> <td>0</td> <td>Enabled</td> </tr> <tr> <td>1</td> <td>1</td> <td>Suspend</td> </tr> </tbody> </table> <p>When in suspend state, downstream propagation of data is blocked on this port, except for port reset. Note that the bit status does not change until the port is suspended and that there may be a delay in suspending a port depending on the activity on the port. The host controller will unconditionally set this bit to a 0 when software sets the <i>Force Port Resume</i> bit to a 0 (from a 1). A write of 0 to this bit is ignored by the host controller.</p> <p>If host software sets this bit to a 1 when the port is not enabled (i.e., Port enabled bit is a 0) the results are undefined.</p>	Port Enabled	Suspend	Port State	0	X	Disabled	1	0	Enabled	1	1	Suspend
Port Enabled	Suspend	Port State											
0	X	Disabled											
1	0	Enabled											
1	1	Suspend											



Bit	Description
6	<p><b>Force Port Resume</b> — R/W.</p> <p>0 = No resume (K-state) detected/driven on port. (Default)                      1 = Resume detected/driven on port. Software sets this bit to a 1 to drive resume signaling. The Host controller sets this bit to a 1 if a J-to-K transition is detected while the port is in the Suspend state. When this bit transitions to a 1 because a J-to-K transition is detected, the Port Change Detect bit (D29:F7, D26:F7:CAPLENGTH + 24h, bit 2) in the USB2.0_STS register is also set to a 1. If software sets this bit to a 1, the host controller must not set the Port Change Detect bit.</p> <p><b>NOTE:</b> When the EHCI controller owns the port, the resume sequence follows the defined sequence documented in the USB Specification, Revision 2.0. The resume signaling (Full-speed 'K') is driven on the port as long as this bit remains a 1. Software must appropriately time the Resume and set this bit to a 0 when the appropriate amount of time has elapsed. Writing a 0 (from 1) causes the port to return to high-speed mode (forcing the bus below the port into a high-speed idle). This bit will remain a 1 until the port has switched to the high-speed idle.</p>
5	<p><b>Overcurrent Change</b> — R/WC. The functionality of this bit is not dependent upon the port owner. Software clears this bit by writing a 1 to it.</p> <p>0 = No change. (Default)                      1 = There is a change to Overcurrent Active.</p>
4	<p>Overcurrent Active — RO.</p> <p>0 = This port does not have an overcurrent condition. (Default)                      1 = This port currently has an overcurrent condition. This bit will automatically transition from 1 to 0 when the over current condition is removed. The ICH8 automatically disables the port when the overcurrent active bit is 1.</p>
3	<p><b>Port Enable/Disable Change</b> — R/WC. For the root hub, this bit gets set to a 1 only when a port is disabled due to the appropriate conditions existing at the EOF2 point (See Chapter 11 of the USB Specification for the definition of a port error). This bit is not set due to the Disabled-to-Enabled transition, nor due to a disconnect. Software clears this bit by writing a 1 to it.</p> <p>0 = No change in status. (Default).                      1 = Port enabled/disabled status has changed.</p>



Bit	Description
2	<p><b>Port Enabled/Disabled</b> — R/W. Ports can only be enabled by the host controller as a part of the reset and enable. Software cannot enable a port by writing a 1 to this bit. Ports can be disabled by either a fault condition (disconnect event or other fault condition) or by host software. Note that the bit status does not change until the port state actually changes. There may be a delay in disabling or enabling a port due to other host controller and bus events.</p> <p>0 = Disable 1 = Enable (Default)</p>
1	<p><b>Connect Status Change</b> — R/WC. This bit indicates a change has occurred in the port's Current Connect Status. Software sets this bit to 0 by writing a 1 to it.</p> <p>0 = No change (Default). 1 = Change in Current Connect Status. The host controller sets this bit for all changes to the port device connect status, even if system software has not cleared an existing connect status change. For example, the insertion status changes twice before system software has cleared the changed condition, hub hardware will be "setting" an already-set bit (i.e., the bit will remain set).</p>
0	<p><b>Current Connect Status</b> — RO. This value reflects the current state of the port, and may not correspond directly to the event that caused the Connect Status Change bit (Bit 1) to be set.</p> <p>0 = No device is present. (Default) 1 = Device is present on port.</p>

### 15.2.3 USB 2.0-Based Debug Port Register

The Debug port's registers are located in the same memory area, defined by the Base Address Register (MEM\_BASE), as the standard EHCI registers. The base offset for the debug port registers (A0h) is declared in the Debug Port Base Offset Capability Register at Configuration offset 5Ah (D29:F7, D26:F7:offset 5Ah). The specific EHCI port that supports this debug capability (Port 0 for D29:F7 and Port 6 for D26:F7) is indicated by a 4-bit field (bits 20–23) in the HCSPARAMS register of the EHCI controller. The address map of the Debug Port registers is shown in [Table 136](#).

**Table 136. Debug Port Register Address Map**

MEM_BASE + Offset	Mnemonic	Register Name	Default	Type
A0–A3h	CNTL_STS	Control/Status	0000000h	R/W, R/WC, RO, WO
A4–A7h	USBPID	USB PIDs	0000000h	R/W, RO
A8–ABh	DATABUF[3:0]	Data Buffer (Bytes 3:0)	0000000h	R/W
AC–AFh	DATABUF[7:4]	Data Buffer (Bytes 7:4)	0000000h	R/W
B0–B3h	CONFIG	Configuration	00007F01h	R/W

**NOTES:**

- All of these registers are implemented in the core well and reset by PLTRST#, EHC HCRESET, and a EHC D3-to-D0 transition.
- The hardware associated with this register provides no checks to ensure that software programs the interface correctly. How the hardware behaves when programmed invalidly is undefined.



### 15.2.3.1 CNTL\_STS—Control/Status Register

Offset: MEM\_BASE + A0h Attribute: R/W, R/WC, RO, WO  
 Default Value: 0000h Size: 32 bits

Bit	Description
31	Reserved
30	<b>OWNER_CNT</b> — R/W. 0 = Ownership of the debug port is NOT forced to the EHCI controller (Default) 1 = Ownership of the debug port is forced to the EHCI controller (i.e. immediately taken away from the companion Classic USB Host controller) If the port was already owned by the EHCI controller, then setting this bit has no effect. This bit overrides all of the ownership-related bits in the standard EHCI registers.
29	Reserved
28	<b>ENABLED_CNT</b> — R/W. 0 = Software can clear this by writing a 0 to it. The hardware clears this bit for the same conditions where the Port Enable/Disable Change bit (in the PORTSC register) is set. (Default) 1 = Debug port is enabled for operation. Software can directly set this bit if the port is already enabled in the associated PORTSC register (this is enforced by the hardware).
27:17	Reserved
16	<b>DONE_STS</b> — R/WC. Software can clear this by writing a 1 to it. 0 = Request Not complete 1 = Set by hardware to indicate that the request is complete.
15:12	<b>LINK_ID_STS</b> — RO. This field identifies the link interface. 0h = Hardwired. Indicates that it is a USB Debug Port.
11	Reserved. This bit returns 0 when read. Writes have no effect.
10	<b>IN_USE_CNT</b> — R/W. Set by software to indicate that the port is in use. Cleared by software to indicate that the port is free and may be used by other software. This bit is cleared after reset. (This bit has no affect on hardware.)
9:7	<b>EXCEPTION_STS</b> — RO. This field indicates the exception when the ERROR_GOOD#_STS bit is set. This field should be ignored if the ERROR_GOOD#_STS bit is 0. 000 = No Error. (Default) Note: this should not be seen, since this field should only be checked if there is an error. 001 = Transaction error: indicates the USB 2.0 transaction had an error (CRC, bad PID, timeout, etc.) 010 = Hardware error. Request was attempted (or in progress) when port was suspended or reset. All Other combinations are reserved
6	<b>ERROR_GOOD#_STS</b> — RO. 0 = Hardware clears this bit to 0 after the proper completion of a read or write. (Default) 1 = Error has occurred. Details on the nature of the error are provided in the Exception field.



Bit	Description
5	<p><b>GO_CNT</b> — WO.</p> <p>0 = Hardware clears this bit when hardware sets the DONE_STS bit. (Default)</p> <p>1 = Causes hardware to perform a read or write request.</p> <p><b>NOTE:</b> Writing a 1 to this bit when it is already set may result in undefined behavior.</p>
4	<p><b>WRITE_READ#_CNT</b> — R/W. Software clears this bit to indicate that the current request is a read. Software sets this bit to indicate that the current request is a write.</p> <p>0 = Read (Default)</p> <p>1 = Write</p>
3:0	<p><b>DATA_LEN_CNT</b> — R/W. This field is used to indicate the size of the data to be transferred. default = 0h.</p> <p>For write operations, this field is set by software to indicate to the hardware how many bytes of data in Data Buffer are to be transferred to the console. A value of 0h indicates that a zero-length packet should be sent. A value of 1–8 indicates 1–8 bytes are to be transferred. Values 9–Fh are invalid and how hardware behaves if used is undefined.</p> <p>For read operations, this field is set by hardware to indicate to software how many bytes in Data Buffer are valid in response to a read operation. A value of 0h indicates that a zero length packet was returned and the state of Data Buffer is not defined. A value of 1–8 indicates 1–8 bytes were received. Hardware is not allowed to return values 9–Fh.</p> <p>The transferring of data always starts with byte 0 in the data area and moves toward byte 7 until the transfer size is reached.</p>

**NOTES:**

1. Software should do Read-Modify-Write operations to this register to preserve the contents of bits not being modified. This include Reserved bits.
2. To preserve the usage of RESERVED bits in the future, software should always write the same value read from the bit until it is defined. Reserved bits will always return 0 when read.

### 15.2.3.2 USBPID—USB PIDs Register

Offset: MEM\_BASE + A4h      Attribute: R/W, RO  
 Default Value: 0000h      Size: 32 bits

This Dword register is used to communicate PID information between the USB debug driver and the USB debug port. The debug port uses some of these fields to generate USB packets, and uses other fields to return PID information to the USB debug driver.

Bit	Description
31:24	Reserved: These bits will return 0 when read. Writes will have no effect.
23:16	<p><b>RECEIVED_PID_STS[23:16]</b> — RO. Hardware updates this field with the received PID for transactions in either direction. When the controller is writing data, this field is updated with the handshake PID that is received from the device. When the host controller is reading data, this field is updated with the data packet PID (if the device sent data), or the handshake PID (if the device NAKs the request). This field is valid when the hardware clears the GO_DONE#_CNT bit.</p>
15:8	<p><b>SEND_PID_CNT[15:8]</b> — R/W. Hardware sends this PID to begin the data packet when sending data to USB (i.e., WRITE_READ#_CNT is asserted). Software typically sets this field to either DATA0 or DATA1 PID values.</p>
7:0	<p><b>TOKEN_PID_CNT[7:0]</b> — R/W. Hardware sends this PID as the Token PID for each USB transaction. Software typically sets this field to either IN, OUT, or SETUP PID values.</p>



### 15.2.3.3 DATABUF[7:0]—Data Buffer Bytes[7:0] Register

Offset: MEM\_BASE + A8h–AFh Attribute: R/W  
 Default Value: 0000000000000000h Size: 64 bits

This register can be accessed as 8 separate 8-bit registers or 2 separate 32-bit register.

Bit	Description
63:0	<p><b>DATABUFFER[63:0]</b> — R/W. This field is the 8 bytes of the data buffer. Bits 7:0 correspond to least significant byte (byte 0). Bits 63:56 correspond to the most significant byte (byte 7).</p> <p>The bytes in the Data Buffer must be written with data before software initiates a write request. For a read request, the Data Buffer contains valid data when DONE_STS bit (offset A0, bit 16) is cleared by the hardware, ERROR_GOOD#_STS (offset A0, bit 6) is cleared by the hardware, and the DATA_LENGTH_CNT field (offset A0, bits 3:0) indicates the number of bytes that are valid.</p>

### 15.2.3.4 CONFIG—Configuration Register

Offset: MEM\_BASE + B0–B3h Attribute: R/W  
 Default Value: 00007F01h Size: 32 bits

Bit	Description
31:15	Reserved
14:8	<p><b>USB_ADDRESS_CNF</b> — R/W. This 7-bit field identifies the USB device address used by the controller for all Token PID generation. (Default = 7Fh)</p>
7:4	Reserved
3:0	<p><b>USB_ENDPOINT_CNF</b> — R/W. This 4-bit field identifies the endpoint used by the controller for all Token PID generation. (Default = 01h)</p>

§ §







# 16 SMBus Controller Registers (D31:F3)

## 16.1 PCI Configuration Registers (SMBUS—D31:F3)

Table 137. SMBus Controller PCI Register Address Map (SMBUS—D31:F3)

Offset	Mnemonic	Register Name	Default	Type
00h–01h	VID	Vendor Identification	8086	RO
02h–03h	DID	Device Identification	See register description	RO
04h–05h	PCICMD	PCI Command	0000h	R/W, RO
06h–07h	PCISTS	PCI Status	0280h	RO, R/WC
08h	RID	Revision Identification	See register description	RO
09h	PI	Programming Interface	00h	RO
0Ah	SCC	Sub Class Code	05h	RO
0Bh	BCC	Base Class Code	0Ch	RO
14h	SMBMBAR1	Memory Based Address Register 1 (Bit 35:32)	00000000h	RO
20h–23h	SMB_BASE	SMBus Base Address	00000001h	R/W, RO
2Ch–2Dh	SVID	Subsystem Vendor Identification	00h	RO
2Eh–2Fh	SID	Subsystem Identification	00h	R/WO
3Ch	INT_LN	Interrupt Line	00h	R/W
3Dh	INT_PN	Interrupt Pin	See register description	RO
40h	HOSTC	Host Configuration	00h	R/W

**NOTE:** Registers that are not shown should be treated as Reserved (See [Section 6.2](#) for details).

### 16.1.1 VID—Vendor Identification Register (SMBUS—D31:F3)

Address: 00h–01h                      Attribute: RO  
 Default Value: 8086h                      Size: 16 bits

Bit	Description
15:0	Vendor ID — RO. This is a 16-bit value assigned to Intel



### 16.1.2 DID—Device Identification Register (SMBUS—D31:F3)

Address: 02h–03h Attribute: RO  
Default Value: See bit description Size: 16 bits

Bit	Description
15:0	Device ID — RO. This is a 16-bit value assigned to the Intel® ICH8 SMBus controller. Refer to the <i>Intel® ICH8 Family Specification Update</i> for the value of the Device ID Register.

### 16.1.3 PCICMD—PCI Command Register (SMBUS—D31:F3)

Address: 04h–05h Attributes: RO, R/W  
Default Value: 0000h Size: 16 bits

Bit	Description
15:11	Reserved
10	<b>Interrupt Disable</b> — R/W. 0 = Enable 1 = Disables SMBus to assert its PIRQB# signal.
9	Fast Back to Back Enable (FBE) — RO. Hardwired to 0.
8	<b>SERR# Enable (SERR_EN)</b> — R/W. 0 = Enables SERR# generation. 1 = Disables SERR# generation.
7	Wait Cycle Control (WCC) — RO. Hardwired to 0.
6	<b>Parity Error Response (PER)</b> — R/W. 0 = Disable 1 = Sets Detected Parity Error bit (D31:F3:06, bit 15) when a parity error is detected.
5	VGA Palette Snoop (VPS) — RO. Hardwired to 0.
4	Postable Memory Write Enable (PMWE) — RO. Hardwired to 0.
3	Special Cycle Enable (SCE) — RO. Hardwired to 0.
2	Bus Master Enable (BME) — RO. Hardwired to 0.
1	Memory Space Enable (MSE) — R/W. 0 = Disables memory mapped configuration space. 1 = Enables memory mapped configuration space.
0	<b>I/O Space Enable (IOSE)</b> — R/W. 0 = Disable 1 = Enables access to the SM Bus I/O space registers as defined by the Base Address Register.



### 16.1.4 PCIISTS—PCI Status Register (SMBUS—D31:F3)

Address: 06h–07h Attributes: RO, R/WC  
 Default Value: 0280h Size: 16 bits

**Note:** For the writable bits, software must write a 1 to clear bits that are set. Writing a 0 to the bit has no effect.

Bit	Description
15	<b>Detected Parity Error (DPE)</b> — R/WC. 0 = No parity error detected. 1 = Parity error detected.
14	<b>Signaled System Error (SSE)</b> — R/WC. 0 = No system error detected. 1 = System error detected.
13	Received Master Abort (RMA) — RO. Hardwired to 0.
12	Received Target Abort (RTA) — RO. Hardwired to 0.
11	<b>Signaled Target Abort (STA)</b> — R/WC. 0 = ICH8 did Not terminate transaction for this function with a target abort. 1 = The function is targeted with a transaction that the Intel® ICH8 terminates with a target abort.
10:9	DEVSEL# Timing Status (DEVT) — RO. This 2-bit field defines the timing for DEVSEL# assertion for positive decode. 01 = Medium timing.
8	Data Parity Error Detected (DPED) — RO. Hardwired to 0.
7	Fast Back to Back Capable (FB2BC) — RO. Hardwired to 1.
6	User Definable Features (UDF) — RO. Hardwired to 0.
5	66 MHz Capable (66MHZ_CAP) — RO. Hardwired to 0.
4	Capabilities List (CAP_LIST) — RO. Hardwired to 0 because there are no capability list structures in this function
3	Interrupt Status (INTS) — RO. This bit indicates that an interrupt is pending. It is independent from the state of the Interrupt Enable bit in the PCI Command register.
2:0	Reserved

### 16.1.5 RID—Revision Identification Register (SMBUS—D31:F3)

Offset Address: 08h Attribute: RO  
 Default Value: See bit description Size: 8 bits

Bit	Description
7:0	Revision ID — RO. Refer to the <i>Intel® I/O Controller Hub 8 (ICH8) Family Specification Update</i> for the value of the Revision ID Register.





### 16.1.10 SMB\_BASE—SMBUS Base Address Register (SMBUS—D31:F3)

Address Offset: 20–23h                      Attribute: R/W, RO  
 Default Value: 00000001h                  Size: 32-bits

Bit	Description
31:16	Reserved — RO
15:5	<b>Base Address</b> — R/W. This field provides the 32-byte system I/O base address for the ICH8 SMB logic.
4:1	Reserved — RO
0	IO Space Indicator — RO. Hardwired to 1 indicating that the SMB logic is I/O mapped.

### 16.1.11 SVID — Subsystem Vendor Identification Register (SMBUS—D31:F2/F4)

Address Offset: 2Ch–2Dh                      Attribute: RO  
 Default Value: 0000h                        Size: 16 bits  
 Lockable: No                                  Power Well: Core

Bit	Description
15:0	Subsystem Vendor ID (SVID) — RO. The SVID register, in combination with the Subsystem ID (SID) register, enables the operating system (OS) to distinguish subsystems from each other. The value returned by reads to this register is the same as that which was written by BIOS into the IDE SVID register. <b>NOTE:</b> Software can write to this register only once per core well reset. Writes should be done as a single 16-bit cycle.

### 16.1.12 SID — Subsystem Identification Register (SMBUS—D31:F2/F4)

Address Offset: 2Eh–2Fh                      Attribute: R/WO  
 Default Value: 00h                            Size: 16 bits  
 Lockable: No                                  Power Well: Core

Bit	Description
15:0	Subsystem ID (SID) — RO. The SID register, in combination with the SVID register, enables the operating system (OS) to distinguish subsystems from each other. The value returned by reads to this register is the same as that which was written by BIOS into the IDE SID register. <b>NOTE:</b> Software can write to this register only once per core well reset. Writes should be done as a single 16-bit cycle.





## 16.2 SMBus I/O and Memory Mapped I/O Registers

Table 138. SMBus I/O and Memory Mapped I/O Register Address Map

SMB_BASE + Offset	Mnemonic	Register Name	Default	Type
00h	HST_STS	Host Status	00h	R/WC, RO, R/WC (special)
02h	HST_CNT	Host Control	00h	R/W, WO
03h	HST_CMD	Host Command	00h	R/W
04h	XMIT_SLVA	Transmit Slave Address	00h	R/W
05h	HST_D0	Host Data 0	00h	R/W
06h	HST_D1	Host Data 1	00h	R/W
07h	HOST_BLOCK_DB	Host Block Data Byte	00h	R/W
08h	PEC	Packet Error Check	00h	R/W
09h	RCV_SLVA	Receive Slave Address	44h	R/W
0Ah–0Bh	SLV_DATA	Receive Slave Data	0000h	RO
0Ch	AUX_STS	Auxiliary Status	00h	R/WC, RO
0Dh	AUX_CTL	Auxiliary Control	00h	R/W
0Eh	SMLINK_PIN_CTL	SMLink Pin Control (TCO Compatible Mode)	See register description	R/W, RO
0Fh	SMBUS_PIN_CTL	SMBus Pin Control	See register description	R/W, RO
10h	SLV_STS	Slave Status	00h	R/WC
11h	SLV_CMD	Slave Command	00h	R/W
14h	NOTIFY_DADDR	Notify Device Address	00h	RO
16h	NOTIFY_DLOW	Notify Data Low Byte	00h	RO
17h	NOTIFY_DHIGH	Notify Data High Byte	00h	RO



### 16.2.1 HST\_STS—Host Status Register (SMBUS—D31:F3)

Register Offset: SMBASE + 00h      Attribute: R/WC, R/WC (special), RO  
 Default Value: 00h      Size: 8-bits

All status bits are set by hardware and cleared by the software writing a one to the particular bit position. Writing a 0 to any bit position has no effect.

Bit	Description
7	<p><b>Byte Done Status (DS) — R/WC.</b>            0 = Software can clear this by writing a 1 to it.            1 = Host controller received a byte (for Block Read commands) or if it has completed transmission of a byte (for Block Write commands) when the 32-byte buffer is not being used. Note that this bit will be set, even on the last byte of the transfer. This bit is not set when transmission is due to the LAN interface heartbeat.            This bit has no meaning for block transfers when the 32-byte buffer is enabled.</p> <p><b>NOTE:</b> When the last byte of a block message is received, the host controller will set this bit. However, it will not immediately set the INTR bit (bit 1 in this register). When the interrupt handler clears the DS bit, the message is considered complete, and the host controller will then set the INTR bit (and generate another interrupt). Thus, for a block message of n bytes, the ICH8 will generate n+1 interrupts. The interrupt handler needs to be implemented to handle these cases. When not using the 32 Byte Buffer, hardware will drive the SMBCLK signal low when the DS bit is set until SW clears the bit. This includes the last byte of a transfer. Software must clear the DS bit before it can clear the BUSY bit.</p>
6	<p><b>INUSE_STS — R/WC (special).</b> This bit is used as semaphore among various independent software threads that may need to use the ICH8's SMBus logic, and has no other effect on hardware.            0 = After a full PCI reset, a read to this bit returns a 0.            1 = After the first read, subsequent reads will return a 1. A write of a 1 to this bit will reset the next read value to 0. Writing a 0 to this bit has no effect. Software can poll this bit until it reads a 0, and will then own the usage of the host controller.</p>
5	<p><b>SMBALERT_STS — R/WC.</b>            0 = Interrupt or SMI# was not generated by SMBALERT#. Software clears this bit by writing a 1 to it.            1 = The source of the interrupt or SMI# was the SMBALERT# signal. This bit is only cleared by software writing a 1 to the bit position or by RSMRST# going low.            If the signal is programmed as a GPIO, then this bit will never be set.</p>
4	<p><b>FAILED — R/WC.</b>            0 = Software clears this bit by writing a 1 to it.            1 = The source of the interrupt or SMI# was a failed bus transaction. This bit is set in response to the KILL bit being set to terminate the host transaction.</p>
3	<p><b>BUS_ERR — R/WC.</b>            0 = Software clears this bit by writing a 1 to it.            1 = The source of the interrupt of SMI# was a transaction collision.</p>
2	<p><b>DEV_ERR — R/WC.</b>            0 = Software clears this bit by writing a 1 to it. The ICH8 will then deassert the interrupt or SMI#.            1 = The source of the interrupt or SMI# was due to one of the following:</p> <ul style="list-style-type: none"> <li>• Invalid Command Field,</li> <li>• Unclaimed Cycle (host initiated),</li> <li>• Host Device Time-out Error.</li> </ul>





Bit	Description
1	<p><b>INTR</b> — R/WC (special). This bit can only be set by termination of a command. INTR is not dependent on the INTREN bit (offset SMBASE + 02h, bit 0) of the Host controller register (offset 02h). It is only dependent on the termination of the command. If the INTREN bit is not set, then the INTR bit will be set, although the interrupt will not be generated. Software can poll the INTR bit in this non-interrupt case.</p> <p>0 = Software clears this bit by writing a 1 to it. The ICH8 then deasserts the interrupt or SMI#.</p> <p>1 = The source of the interrupt or SMI# was the successful completion of its last command.</p>
0	<p><b>HOST_BUSY</b> — R/WC.</p> <p>0 = Cleared by the ICH8 when the current transaction is completed.</p> <p>1 = Indicates that the ICH8 is running a command from the host interface. No SMB registers should be accessed while this bit is set, except the BLOCK DATA BYTE Register. The BLOCK DATA BYTE Register can be accessed when this bit is set only when the SMB_CMD bits in the Host Control Register are programmed for Block command or I<sup>2</sup>C Read command. This is necessary in order to check the DONE_STS bit.</p>

### 16.2.2 HST\_CNT—Host Control Register (SMBUS—D31:F3)

Register Offset: SMBASE + 02h                      Attribute:                      R/W, WO  
 Default Value: 00h                                      Size:                                8-bits

**Note:** A read to this register will clear the byte pointer of the 32-byte buffer.

Bit	Description
7	<p><b>PEC_EN.</b> — R/W.</p> <p>0 = SMBus host controller does not perform the transaction with the PEC phase appended.</p> <p>1 = Causes the host controller to perform the SMBus transaction with the Packet Error Checking phase appended. For writes, the value of the PEC byte is transferred from the PEC Register. For reads, the PEC byte is loaded in to the PEC Register. This bit must be written prior to the write in which the <b>START</b> bit is set.</p>
6	<p><b>START</b> — WO.</p> <p>0 = This bit will always return 0 on reads. The HOST_BUSY bit in the Host Status register (offset 00h) can be used to identify when the Intel<sup>®</sup> ICH8 has finished the command.</p> <p>1 = Writing a 1 to this bit initiates the command described in the SMB_CMD field. All registers should be setup prior to writing a 1 to this bit position.</p>
5	<p><b>LAST_BYTE</b> — WO. This bit is used for Block Read commands.</p> <p>1 = Software sets this bit to indicate that the next byte will be the last byte to be received for the block. This causes the ICH8 to send a NACK (instead of an ACK) after receiving the last byte.</p> <p><b>NOTE:</b> Once the SECOND_TO_STS bit in TCO2_STS register (D31:F0, TCOBASE+6h, bit 1) is set, the LAST_BYTE bit also gets set. While the SECOND_TO_STS bit is set, the LAST_BYTE bit cannot be cleared. This prevents the ICH8 from running some of the SMBus commands (Block Read/Write, I<sup>2</sup>C Read, Block I<sup>2</sup>C Write).</p>



Bit	Description
4:2	<p><b>SMB_CMD</b> — R/W. The bit encoding below indicates which command the ICH8 is to perform. If enabled, the ICH8 will generate an interrupt or SMI# when the command has completed. If the value is for a non-supported or reserved command, the ICH8 will set the device error (DEV_ERR) status bit (offset SMBASE + 00h, bit 2) and generate an interrupt when the START bit is set. The ICH8 will perform no command, and will not operate until DEV_ERR is cleared.</p> <p>000 = <b>Quick</b>: The slave address and read/write value (bit 0) are stored in the transmit slave address register.</p> <p>001 = <b>Byte</b>: This command uses the transmit slave address and command registers. Bit 0 of the slave address register determines if this is a read or write command.</p> <p>010 = <b>Byte Data</b>: This command uses the transmit slave address, command, and DATA0 registers. Bit 0 of the slave address register determines if this is a read or write command. If it is a read, the DATA0 register will contain the read data.</p> <p>011 = <b>Word Data</b>: This command uses the transmit slave address, command, DATA0 and DATA1 registers. Bit 0 of the slave address register determines if this is a read or write command. If it is a read, after the command completes, the DATA0 and DATA1 registers will contain the read data.</p> <p>100 = <b>Process Call</b>: This command uses the transmit slave address, command, DATA0 and DATA1 registers. Bit 0 of the slave address register determines if this is a read or write command. After the command completes, the DATA0 and DATA1 registers will contain the read data.</p> <p>101 = <b>Block</b>: This command uses the transmit slave address, command, DATA0 registers, and the Block Data Byte register. For block write, the count is stored in the DATA0 register and indicates how many bytes of data will be transferred. For block reads, the count is received and stored in the DATA0 register. Bit 0 of the slave address register selects if this is a read or write command. For writes, data is retrieved from the first n (where n is equal to the specified count) addresses of the SRAM array. For reads, the data is stored in the Block Data Byte register.</p> <p>110 = <b>I<sup>2</sup>C Read</b>: This command uses the transmit slave address, command, DATA0, DATA1 registers, and the Block Data Byte register. The read data is stored in the Block Data Byte register. The ICH8 continues reading data until the NAK is received.</p> <p>111 = <b>Block Process</b>: This command uses the transmit slave address, command, DATA0 and the Block Data Byte register. For block write, the count is stored in the DATA0 register and indicates how many bytes of data will be transferred. For block read, the count is received and stored in the DATA0 register. Bit 0 of the slave address register always indicate a write command. For writes, data is retrieved from the first m (where m is equal to the specified count) addresses of the SRAM array. For reads, the data is stored in the Block Data Byte register.</p> <p><b>NOTE:</b> E32B bit in the Auxiliary Control register must be set for this command to work.</p>
1	<p><b>KILL</b> — R/W.</p> <p>0 = Normal SMBus host controller functionality.</p> <p>1 = Kills the current host transaction taking place, sets the FAILED status bit, and asserts the interrupt (or SMI#). This bit, once set, must be cleared by software to allow the SMBus host controller to function normally.</p>
0	<p><b>INTREN</b> — R/W.</p> <p>0 = Disable.</p> <p>1 = Enable the generation of an interrupt or SMI# upon the completion of the command.</p>



### 16.2.3 HST\_CMD—Host Command Register (SMBUS—D31:F3)

Register Offset: SMBASE + 03h                      Attribute:            R/W  
 Default Value:    00h                                      Size:                    8 bits

Bit	Description
7:0	This 8-bit field is transmitted by the host controller in the command field of the SMBus protocol during the execution of any command.

### 16.2.4 XMIT\_SLVA—Transmit Slave Address Register (SMBUS—D31:F3)

Register Offset: SMBASE + 04h                      Attribute:            R/W  
 Default Value:    00h                                      Size:                    8 bits

This register is transmitted by the host controller in the slave address field of the SMBus protocol.

Bit	Description
7:1	<b>Address</b> — R/W. This field provides a 7-bit address of the targeted slave.
0	<b>Read-Write</b> — R/W. Direction of the host transfer. 0 = Write 1 = Read

### 16.2.5 HST\_D0—Host Data 0 Register (SMBUS—D31:F3)

Register Offset: SMBASE + 05h                      Attribute:            R/W  
 Default Value:    00h                                      Size:                    8 bits

Bit	Description
7:0	<b>Data0/Count</b> — R/W. This field contains the 8-bit data sent in the DATA0 field of the SMBus protocol. For block write commands, this register reflects the number of bytes to transfer. This register should be programmed to a value between 1 and 32 for block counts. A count of 0 or a count above 32 will result in unpredictable behavior. The host controller does not check or log invalid block counts.

### 16.2.6 HST\_D1—Host Data 1 Register (SMBUS—D31:F3)

Register Offset: SMBASE + 06h                      Attribute:            R/W  
 Default Value:    00h                                      Size:                    8 bits

Bit	Description
7:0	<b>Data1</b> — R/W. This 8-bit register is transmitted in the DATA1 field of the SMBus protocol during the execution of any command.



### 16.2.7 Host\_BLOCK\_DB—Host Block Data Byte Register (SMBUS—D31:F3)

Register Offset: SMBASE + 07h                      Attribute:                      R/W  
 Default Value: 00h                                      Size:                                8 bits

Bit	Description
7:0	<p><b>Block Data (BDTA)</b> — R/W. This is either a register, or a pointer into a 32-byte block array, depending upon whether the E32B bit is set in the Auxiliary Control register. When the E32B bit (offset SMBASE + 0Dh, bit 1) is cleared, this is a register containing a byte of data to be sent on a block write or read from on a block read, just as it behaved on the ICH3.</p> <p>When the E32B bit is set, reads and writes to this register are used to access the 32-byte block data storage array. An internal index pointer is used to address the array, which is reset to 0 by reading the HCTL register (offset 02h). The index pointer then increments automatically upon each access to this register. The transfer of block data into (read) or out of (write) this storage array during an SMBus transaction always starts at index address 0.</p> <p>When the E2B bit is set, for writes, software will write up to 32-bytes to this register as part of the setup for the command. After the Host controller has sent the Address, Command, and Byte Count fields, it will send the bytes in the SRAM pointed to by this register.</p> <p>When the E2B bit is cleared for writes, software will place a single byte in this register. After the host controller has sent the address, command, and byte count fields, it will send the byte in this register. If there is more data to send, software will write the next series of bytes to the SRAM pointed to by this register and clear the DONE_STS bit. The controller will then send the next byte. During the time between the last byte being transmitted to the next byte being transmitted, the controller will insert wait-states on the interface.</p> <p>When the E2B bit is set for reads, after receiving the byte count into the Data0 register, the first series of data bytes go into the SRAM pointed to by this register. If the byte count has been exhausted or the 32-byte SRAM has been filled, the controller will generate an SMI# or interrupt (depending on configuration) and set the DONE_STS bit. Software will then read the data. During the time between when the last byte is read from the SRAM to when the DONE_STS bit is cleared, the controller will insert wait-states on the interface.</p>

### 16.2.8 PEC—Packet Error Check (PEC) Register (SMBUS—D31:F3)

Register Offset: SMBASE + 08h                      Attribute:                      R/W  
 Default Value: 00h                                      Size:                                8 bits

Bit	Description
7:0	<p><b>PEC_DATA</b> — R/W. This 8-bit register is written with the 8-bit CRC value that is used as the SMBus PEC data prior to a write transaction. For read transactions, the PEC data is loaded from the SMBus into this register and is then read by software. Software must ensure that the INUSE_STS bit is properly maintained to avoid having this field overwritten by a write transaction following a read transaction.</p>



### 16.2.9 RCV\_SLVA—Receive Slave Address Register (SMBUS—D31:F3)

Register Offset: SMBASE + 09h      Attribute: R/W  
 Default Value: 44h      Size: 8 bits  
 Lockable: No      Power Well: Resume

Bit	Description
7	Reserved
6:0	<b>SLAVE_ADDR</b> — R/W. This field is the slave address that the Intel® ICH8 decodes for read and write cycles. the default is not 0, so the SMBus Slave Interface can respond even before the processor comes up (or if the processor is dead). This register is cleared by RSMRST#, but not by PLTRST#.

### 16.2.10 SLV\_DATA—Receive Slave Data Register (SMBUS—D31:F3)

Register Offset: SMBASE + 0Ah–0Bh      Attribute: RO  
 Default Value: 0000h      Size: 16 bits  
 Lockable: No      Power Well: Resume

This register contains the 16-bit data value written by the external SMBus master. The processor can then read the value from this register. This register is reset by RSMRST#, but not PLTRST#.

Bit	Description
15:8	<b>Data Message Byte 1 (DATA_MSG1)</b> — RO. See <a href="#">Section 5.20.7</a> for a discussion of this field.
7:0	<b>Data Message Byte 0 (DATA_MSG0)</b> — RO. See <a href="#">Section 5.20.7</a> for a discussion of this field.

### 16.2.11 AUX\_STS—Auxiliary Status Register (SMBUS—D31:F3)

Register Offset: SMBASE + 0Ch      Attribute: R/WC, RO  
 Default Value: 00h      Size: 8 bits  
 Lockable: No      Power Well: Resume

Bit	Description
7:2	Reserved
1	<b>SMBus TCO Mode (STCO)</b> — RO. This bit reflects the strap setting of TCO compatible mode vs. Advanced TCO mode. 0 = Intel® ICH8 is in the compatible TCO mode. 1 = ICH8 is in the advanced TCO mode. This register reflects the value of bit 7 in <a href="#">Section 20.2.5.1</a> .
0	<b>CRC Error (CRCE)</b> — R/WC. 0 = Software clears this bit by writing a 1 to it. 1 = This bit is set if a received message contained a CRC error. When this bit is set, the DERR bit of the host status register will also be set. This bit will be set by the controller if a software abort occurs in the middle of the CRC portion of the cycle or an abort happens after the ICH8 has received the final data bit transmitted by an external slave.



### 16.2.12 AUX\_CTL—Auxiliary Control Register (SMBUS—D31:F3)

Register Offset: SMBASE + 0Dh                      Attribute: R/W  
 Default Value: 00h                                      Size: 8 bits  
 Lockable: No    Power Well: Resume

Bit	Description
7:2	Reserved
1	<b>Enable 32-Byte Buffer (E32B)</b> — R/W. 0 = Disable. 1 = Enable. When set, the Host Block Data register is a pointer into a 32-byte buffer, as opposed to a single register. This enables the block commands to transfer or receive up to 32-bytes before the ICH8 generates an interrupt.
0	<b>Automatically Append CRC (AAC)</b> — R/W. 0 = ICH8 will Not automatically append the CRC. 1 = The ICH8 will automatically append the CRC. This bit must not be changed during SMBus transactions or undetermined behavior will result. It should be programmed only once during the lifetime of the function.

### 16.2.13 SMLINK\_PIN\_CTL—SMLink Pin Control Register (SMBUS—D31:F3)

Register Offset: SMBASE + 0Eh                      Attribute: R/W, RO  
 Default Value: See below                              Size: 8 bits

**Note:** This register is in the resume well and is reset by RSMRST#.  
 This register is only applicable in the TCO compatible mode.

Bit	Description
7:3	Reserved
2	<b>SMLINK_CLK_CTL</b> — R/W. 0 = ICH8 will drive the SMLINK0 pin low, independent of what the other SMLINK logic would otherwise indicate for the SMLINK0 pin. 1 = The SMLINK0 pin is <b>not</b> overdriven low. The other SMLINK logic controls the state of the pin. (Default)
1	<b>SMLINK1_CUR_STS</b> — RO. This read-only bit has a default value that is dependent on an external signal level. This pin returns the value on the SMLINK1 pin. This allows software to read the current state of the pin. 0 = Low 1 = High
0	<b>SMLINK0_CUR_STS</b> — RO. This read-only bit has a default value that is dependent on an external signal level. This pin returns the value on the SMLINK0 pin. This allows software to read the current state of the pin. 0 = Low 1 = High



### 16.2.14 SMBUS\_PIN\_CTL—SMBus Pin Control Register (SMBUS—D31:F3)

Register Offset: SMBASE + 0Fh                      Attribute:                      R/W, RO  
 Default Value:    See below                              Size:                              8 bits

**Note:** This register is in the resume well and is reset by RSMRST#.

Bit	Description
7:3	Reserved
2	<b>SMBCLK_CTL</b> — R/W. 0 = ICH8 drives the SMBCLK pin low, independent of what the other SMB logic would otherwise indicate for the SMBCLK pin. (Default) 1 = The SMBCLK pin is <b>not</b> overdriven low. The other SMBus logic controls the state of the pin.
1	<b>SMBDATA_CUR_STS</b> — RO. This read-only bit has a default value that is dependent on an external signal level. This pin returns the value on the SMBDATA pin. This allows software to read the current state of the pin. 0 = Low 1 = High
0	<b>SMBCLK_CUR_STS</b> — RO. This read-only bit has a default value that is dependent on an external signal level. This pin returns the value on the SMBCLK pin. This allows software to read the current state of the pin. 0 = Low 1 = High

### 16.2.15 SLV\_STS—Slave Status Register (SMBUS—D31:F3)

Register Offset: SMBASE + 10h                      Attribute:                      R/WC  
 Default Value:    00h    Size:                              8 bits

**Note:** This register is in the resume well and is reset by RSMRST#.

All bits in this register are implemented in the 64 kHz clock domain. Therefore, software must poll this register until a write takes effect before assuming that a write has completed internally.

Bit	Description
7:1	Reserved
0	<b>HOST_NOTIFY_STS</b> — R/WC. The ICH8 sets this bit to a 1 when it has completely received a successful Host Notify Command on the SMLink pins. Software reads this bit to determine that the source of the interrupt or SMI# was the reception of the Host Notify Command. Software clears this bit after reading any information needed from the Notify address and data registers by writing a 1 to this bit. Note that the ICH8 will allow the Notify Address and Data registers to be over-written once this bit has been cleared. When this bit is 1, the ICH8 will NACK the first byte (host address) of any new "Host Notify" commands on the SMLink. Writing a 0 to this bit has no effect.



### 16.2.16 SLV\_CMD—Slave Command Register (SMBUS—D31:F3)

Register Offset: SMBASE + 11h                      Attribute:                      R/W  
 Default Value: 00h                                      Size:                              8 bits

**Note:** This register is in the resume well and is reset by RSMRST#.

Bit	Description
7:2	Reserved
2	<p><b>SMBALERT_DIS</b> — R/W.</p> <p>0 = Allows the generation of the interrupt or SMI#.</p> <p>1 = Software sets this bit to block the generation of the interrupt or SMI# due to the SMBALERT# source. This bit is logically inverted and ANDed with the SMBALERT_STS bit (offset SMBASE + 00h, bit 5). The resulting signal is distributed to the SMI# and/or interrupt generation logic. This bit does not effect the wake logic.</p>
1	<p><b>HOST_NOTIFY_WKEN</b> — R/W. Software sets this bit to 1 to enable the reception of a Host Notify command as a wake event. When enabled this event is “OR”d in with the other SMBus wake events and is reflected in the SMB_WAK_STS bit of the General Purpose Event 0 Status register.</p> <p>0 = Disable            1 = Enable</p>
0	<p><b>HOST_NOTIFY_INTREN</b> — R/W. Software sets this bit to 1 to enable the generation of interrupt or SMI# when HOST_NOTIFY_STS (offset SMBASE + 10h, bit 0) is 1. This enable does not affect the setting of the HOST_NOTIFY_STS bit. When the interrupt is generated, either PIRQB# or SMI# is generated, depending on the value of the SMB_SMI_EN bit (D31:F3:40h, bit 1). If the HOST_NOTIFY_STS bit is set when this bit is written to a 1, then the interrupt (or SMI#) will be generated. The interrupt (or SMI#) is logically generated by AND’ing the STS and INTREN bits.</p> <p>0 = Disable            1 = Enable</p>

### 16.2.17 NOTIFY\_DADDR—Notify Device Address Register (SMBUS—D31:F3)

Register Offset: SMBASE + 14h                      Attribute:                      RO  
 Default Value: 00h                                      Size:                              8 bits

**Note:** This register is in the resume well and is reset by RSMRST#.

Bit	Description
7:1	<p><b>DEVICE_ADDRESS</b> — RO. This field contains the 7-bit device address received during the Host Notify protocol of the SMBus 2.0 Specification. Software should only consider this field valid when the HOST_NOTIFY_STS bit (D31:F3:SMBASE + 10, bit 0) is set to 1.</p>
0	Reserved





### 16.2.18 NOTIFY\_DLOW—Notify Data Low Byte Register (SMBUS—D31:F3)

Register Offset: SMBASE + 16h                      Attribute:              RO  
 Default Value: 00h                                      Size:                      8 bits

**Note:** This register is in the resume well and is reset by RSMRST#.

Bit	Description
7:0	<b>DATA_LOW_BYTE</b> — RO. This field contains the first (low) byte of data received during the Host Notify protocol of the SMBus 2.0 specification. Software should only consider this field valid when the HOST_NOTIFY_STS bit (D31:F3:SMBASE +10, bit 0) is set to 1.

### 16.2.19 NOTIFY\_DHIGH—Notify Data High Byte Register (SMBUS—D31:F3)

Register Offset: SMBASE + 17h                      Attribute:              RO  
 Default Value: 00h                                      Size:                      8 bits

**Note:** This register is in the resume well and is reset by RSMRST#.

Bit	Description
7:0	<b>DATA_HIGH_BYTE</b> — RO. This field contains the second (high) byte of data received during the Host Notify protocol of the SMBus 2.0 specification. Software should only consider this field valid when the HOST_NOTIFY_STS bit (D31:F3:SMBASE +10, bit 0) is set to 1.

§ §





# 17 Intel® High Definition Audio Controller Registers (D27:F0)

The Intel High Definition Audio controller resides in PCI Device 27, Function 0 on bus 0. This function contains a set of DMA engines that are used to move samples of digitally encoded data between system memory and external codecs.

**Note:** All registers in this function (including memory-mapped registers) must be addressable in byte, word, and DWord quantities. The software must always make register accesses on natural boundaries (i.e., DWord accesses must be on DWord boundaries; word accesses on word boundaries, etc.) In addition, the memory-mapped register space must not be accessed with the LOCK semantic exclusive-access mechanism. If software attempts exclusive-access mechanisms to the Intel High Definition Audio memory-mapped space, the results are undefined.

**Note:** Users interested in providing feedback on the Intel High Definition Audio specification or planning to implement the Intel High Definition Audio specification into a future product will need to execute the *Intel® High Definition Audio Specification Developer's Agreement*. For more information, contact [nextgenaudio@intel.com](mailto:nextgenaudio@intel.com).

## 17.1 Intel® High Definition Audio PCI Configuration Space (Intel® High Definition Audio— D27:F0)

**Note:** Address locations that are not shown should be treated as Reserved.

**Table 139. Intel® High Definition Audio PCI Register Address Map (Intel® High Definition Audio D27:F0)**

Offset	Mnemonic	Register Name	Default	Access
00h–01h	VID	Vendor Identification	8086h	RO
02h–03h	DID	Device Identification	See register description	RO
04h–05h	PCICMD	PCI Command	0000h	R/W, RO
06h–07h	PCISTS	PCI Status	0010h	R/WC, RO
08h	RID	Revision Identification	See register description	RO
09h	PI	Programming Interface	00h	RO
0Ah	SCC	Sub Class Code	03h	RO
0Bh	BCC	Base Class Code	04h	RO
0Ch	CLS	Cache Line Size	00h	R/W
0Dh	LT	Latency Timer	00h	RO
0Eh	HEADTYP	Header Type	00h	RO
10h–13h	HDBARL	Intel® High Definition Audio Lower Base Address (Memory)	00000004h	R/W, RO
14h–17h	HDBARU	Intel High Definition Audio Upper Base Address (Memory)	00000000h	R/W
2Ch–2Dh	SVID	Subsystem Vendor Identification	0000h	R/WO



**Table 139. Intel® High Definition Audio PCI Register Address Map (Intel® High Definition Audio D27:F0)**

Offset	Mnemonic	Register Name	Default	Access
2Eh–2Fh	SID	Subsystem Identification	0000h	R/WO
34h	CAPPTR	Capability List Pointer	50h	RO
3Ch	INTLN	Interrupt Line	00h	R/W
3Dh	INTPN	Interrupt Pin	See Register Description	RO
40h	HDCTL	Intel High Definition Audio Control	00h	R/W, RO
44h	TCSEL	Traffic Class Select	00h	R/W
4Ch	DCKCTL	Docking Control (Mobile Only)	00h	R/W, RO
4Dh	DCKSTS	Docking Status (Mobile Only)	80h	R/WO, RO
50h–51h	PID	PCI Power Management Capability ID	6001h	RO
52h–53h	PC	Power Management Capabilities	C842	RO
54h–57h	PCS	Power Management Control and Status	00000000h	R/W, RO, R/WC
60h–61h	MID	MSI Capability ID	7005h	RO
62h–63h	MMC	MSI Message Control	0080h	R/W, RO
64h–67h	MMLA	MSI Message Lower Address	00000000h	R/W, RO
68h–6Bh	MMUA	SMI Message Upper Address	00000000h	R/W
6Ch–6Dh	MMD	MSI Message Data	0000h	R/W
70h–71h	PXID	PCI Express* Capability Identifiers	0010h	RO
72h–73h	PXC	PCI Express Capabilities	0091h	RO
74h–77h	DEVCAP	Device Capabilities	00000000h	RO, R/WO
78h–79h	DEVC	Device Control	0800h	R/W, RO
7Ah–7Bh	DEVS	Device Status	0010h	RO
100h–103h	VCCAP	Virtual Channel Enhanced Capability Header	13010002h	RO
104h–107h	PVCCAP1	Port VC Capability Register 1	00000001h	RO
108h–10Bh	PVCCAP2	Port VC Capability Register 2	00000000h	RO
10Ch–10D	PVCCTL	Port VC Control	0000h	RO
10Eh–10Fh	PVCSTS	Port VC Status	0000h	RO
110h–103h	VC0CAP	VC0 Resource Capability	00000000h	RO
114h–117h	VC0CTL	VC0 Resource Control	800000FFh	R/W, RO
11Ah–11Bh	VC0STS	VC0 Resource Status	0000h	RO
11Ch–11Fh	VCiCAP	VCi Resource Capability	00000000h	RO
120h–123h	VCiCTL	VCi Resource Control	00000000h	R/W, RO
126h–127h	VCiSTS	VCi Resource Status	0000h	RO
130h–133h	RCCAP	Root Complex Link Declaration Enhanced Capability Header	00010005h	RO
134h–137h	ESD	Element Self Description	0F000100h	RO



**Table 139. Intel® High Definition Audio PCI Register Address Map (Intel® High Definition Audio D27:F0)**

Offset	Mnemonic	Register Name	Default	Access
140h–143h	L1DESC	Link 1 Description	00000001h	RO
148h–14Bh	L1ADDL	Link 1 Lower Address	See Register Description	RO
14Ch–14Fh	L1ADDU	Link 1 Upper Address	00000000h	RO

### 17.1.1 VID—Vendor Identification Register (Intel® High Definition Audio Controller—D27:F0)

Offset: 00h-01h Attribute: RO  
 Default Value: 8086h Size: 16 bits

Bit	Description
15:0	<b>Vendor ID</b> — RO. This is a 16-bit value assigned to Intel. Intel VID = 8086h

### 17.1.2 DID—Device Identification Register (Intel® High Definition Audio Controller—D27:F0)

Offset Address: 02h–03h Attribute: RO  
 Default Value: See bit description Size: 16 bits

Bit	Description
15:0	<b>Device ID</b> — RO. This is a 16-bit value assigned to the Intel® ICH8 Intel High Definition Audio controller. Refer to the <i>Intel® ICH8 Family Specification Update</i> for the value of the Device ID Register.



### 17.1.3 PCICMD—PCI Command Register (Intel® High Definition Audio Controller—D27:F0)

Offset Address: 04h–05h  
Default Value: 0000h

Attribute: R/W, RO  
Size: 16 bits

Bit	Description
15:11	Reserved
10	Interrupt Disable (ID) — R/W. 0 = The INTx# signals may be asserted. 1 = The Intel® High Definition Audio controller's INTx# signal will be de-asserted Note that this bit does not affect the generation of MSIs.
9	Fast Back to Back Enable (FBE) — RO. Not implemented. Hardwired to 0.
8	SERR# Enable (SERR_EN) — R/W. SERR# is not generated by the ICH8 Intel High Definition Audio Controller.
7	Wait Cycle Control (WCC) — RO. Not implemented. Hardwired to 0.
6	Parity Error Response (PER) — RO. Not implemented. Hardwired to 0.
5	VGA Palette Snoop (VPS). Not implemented. Hardwired to 0.
4	Memory Write and Invalidate Enable (MWIE) — RO. Not implemented. Hardwired to 0.
3	Special Cycle Enable (SCE). Not implemented. Hardwired to 0.
2	<b>Bus Master Enable (BME)</b> — R/W. This bit controls standard PCI Express* bus mastering capabilities for Memory and I/O, reads and writes. Note that this bit also controls MSI generation since MSIs are essentially Memory writes. 0 = Disable 1 = Enable
1	<b>Memory Space Enable (MSE)</b> — R/W. This bit enables memory space addresses to the Intel High Definition Audio controller. 0 = Disable 1 = Enable
0	I/O Space Enable (IOSE)—RO. Hardwired to 0 since the Intel High Definition Audio controller does not implement I/O space.



### 17.1.4 PCISTS—PCI Status Register (Intel® High Definition Audio Controller—D27:F0)

Offset Address: 06h–07h                      Attribute:              RO, R/WC  
 Default Value: 0010h                      Size:                      16 bits

Bit	Description
15	Detected Parity Error (DPE) — RO. Not implemented. Hardwired to 0.
14	SERR# Status (SERRS) — RO. Not implemented. Hardwired to 0.
13	Received Master Abort (RMA) — R/WC. Software clears this bit by writing a 1 to it. 0 = No master abort received. 1 = The Intel® High Definition Audio controller sets this bit when, as a bus master, it receives a master abort. When set, the Intel High Definition Audio controller clears the run bit for the channel that received the abort.
12	Received Target Abort (RTA) — RO. Not implemented. Hardwired to 0.
11	Signaled Target Abort (STA) — RO. Not implemented. Hardwired to 0.
10:9	DEVSEL# Timing Status (DEV_STS) — RO. Does not apply. Hardwired to 0.
8	Data Parity Error Detected (DPED) — RO. Not implemented. Hardwired to 0.
7	Fast Back to Back Capable (FB2BC) — RO. Does not apply. Hardwired to 0.
6	Reserved.
5	66 MHz Capable (66MHZ_CAP) — RO. Does not apply. Hardwired to 0.
4	Capabilities List (CAP_LIST) — RO. Hardwired to 1. Indicates that the controller contains a capabilities pointer list. The first item is pointed to by looking at configuration offset 34h.
3	Interrupt Status (IS) — RO. 0 = This bit is 0 after the interrupt is cleared. 1 = INTx# is asserted. Note that this bit is not set by an MSI.
2:0	Reserved.

### 17.1.5 RID—Revision Identification Register (Intel® High Definition Audio Controller—D27:F0)

Offset:                      08h                      Attribute:              RO  
 Default Value:              See bit description              Size:                      8 Bits

Bit	Description
7:0	Revision ID — RO. Refer to the <i>Intel® I/O Controller Hub 8 (ICH8) Family Specification Update</i> for the value of the Revision ID Register



### 17.1.6 PI—Programming Interface Register (Intel® High Definition Audio Controller—D27:F0)

Offset: 09h Attribute: RO  
Default Value: 00h Size: 8 bits

Bit	Description
7:0	Programming Interface — RO.

### 17.1.7 SCC—Sub Class Code Register (Intel® High Definition Audio Controller—D27:F0)

Address Offset: 0Ah Attribute: RO  
Default Value: 03h Size: 8 bits

Bit	Description
7:0	Sub Class Code (SCC) — RO. 03h = Audio Device

### 17.1.8 BCC—Base Class Code Register (Intel® High Definition Audio Controller—D27:F0)

Address Offset: 0Bh Attribute: RO  
Default Value: 04h Size: 8 bits

Bit	Description
7:0	Base Class Code (BCC) — RO. 04h = Multimedia device

### 17.1.9 CLS—Cache Line Size Register (Intel® High Definition Audio Controller—D27:F0)

Address Offset: 0Ch Attribute: R/W  
Default Value: 00h Size: 8 bits

Bit	Description
7:0	Cache Line Size — R/W. Implemented as R/W register, but has no functional impact to the ICH8

### 17.1.10 LT—Latency Timer Register (Intel® High Definition Audio Controller—D27:F0)

Address Offset: 0Dh Attribute: RO  
Default Value: 00h Size: 8 bits

Bit	Description
7:0	Latency Timer — RO. Hardwired to 00







### 17.1.14 SVID—Subsystem Vendor Identification Register (Intel® High Definition Audio Controller—D27:F0)

Address Offset: 2Ch–2Dh                      Attribute: R/WO  
Default Value: 0000h                      Size: 16 bits

The SVID register, in combination with the Subsystem ID register (D27:F0:2Eh), enable the operating environment to distinguish one audio subsystem from the other(s).

This register is implemented as write-once register. Once a value is written to it, the value can be read back. Any subsequent writes will have no effect.

This register is not affected by the D3<sub>HOT</sub> to D0 transition.

Bit	Description
15:0	Subsystem Vendor ID — R/WO.

### 17.1.15 SID—Subsystem Identification Register (Intel® High Definition Audio Controller—D27:F0)

Address Offset: 2Eh–2Fh                      Attribute: R/WO  
Default Value: 0000h                      Size: 16 bits

The SID register, in combination with the Subsystem Vendor ID register (D27:F0:2Ch) make it possible for the operating environment to distinguish one audio subsystem from the other(s).

This register is implemented as write-once register. Once a value is written to it, the value can be read back. Any subsequent writes will have no effect.

This register is not affected by the D3<sub>HOT</sub> to D0 transition.

Bit	Description
15:0	<b>Subsystem ID</b> — R/WO.

### 17.1.16 CAPPTR—Capabilities Pointer Register (Audio—D30:F2)

Address Offset: 34h                              Attribute: RO  
Default Value: 50h                              Size: 8 bits

This register indicates the offset for the capability pointer.

Bit	Description
7:0	Capabilities Pointer (CAP_PTR) — RO. This field indicates that the first capability pointer offset is offset 50h (Power Management Capability)









### 17.1.24 PC—Power Management Capabilities Register (Intel® High Definition Audio Controller—D27:F0)

Address Offset: 52h-53h                      Attribute: RO  
 Default Value: C842h                        Size: 16 bits

Bit	Description
15:11	PME Support — RO. Hardwired to 11001b. Indicates PME# can be generated from D3 and D0 states.
10	D2 Support — RO. Hardwired to 0. Indicates that D2 state is not supported.
9	D1 Support —RO. Hardwired to 0. Indicates that D1 state is not supported.
8:6	Aux Current — RO. Hardwired to 001b. Reports 55 mA maximum suspend well current required when in the D3 <sub>COLD</sub> state.
5	Device Specific Initialization (DSI) — RO. Hardwired to 0. Indicates that no device specific initialization is required.
4	Reserved
3	PME Clock (PMEC) — RO. Does not apply. Hardwired to 0.
2:0	Version — RO. Hardwired to 010b. Indicates support for version 1.1 of the PCI Power Management Specification.

### 17.1.25 PCS—Power Management Control and Status Register (Intel® High Definition Audio Controller—D27:F0)

Address Offset: 54h-57h                      Attribute: RO, R/W, R/WC  
 Default Value: 00000000h                    Size: 32 bits

Bit	Description
31:24	Data — RO. Does not apply. Hardwired to 0.
23	Bus Power/Clock Control Enable — RO. Does not apply. Hardwired to 0.
22	B2/B3 Support — RO. Does not apply. Hardwired to 0.
21:16	Reserved.
15	<b>PME Status (PMES)</b> — R/WC. 0 = Software clears the bit by writing a 1 to it. 1 = This bit is set when the Intel® High Definition Audio controller would normally assert the PME# signal independent of the state of the PME_EN bit (bit 8 in this register)  This bit is in the resume well and only cleared on a power-on reset. Software must not make assumptions about the reset state of this bit and must set it appropriately.
14:9	Reserved
8	<b>PME Enable (PMEE)</b> — R/W. 0 = Disable 1 = Enable. When set and if corresponding PMES also set, the Intel High Definition Audio controller sets the PME_BO_STS bit in the GPE0_STS register (PMBASE +28h).  This bit is in the resume well and only cleared on a power-on reset. Software must not make assumptions about the reset state of this bit and must set it appropriately.
7:2	Reserved



Bit	Description
1:0	<p><b>Power State (PS)</b> — R/W. This field is used both to determine the current power state of the Intel High Definition Audio controller and to set a new power state.</p> <p>00 = D0 state 11 = D3<sub>HOT</sub> state Others = reserved</p> <p><b>NOTES:</b></p> <ol style="list-style-type: none"> <li>1. If software attempts to write a value of 01b or 10b in to this field, the write operation must complete normally; however, the data is discarded and no state change occurs.</li> <li>2. When in the D3<sub>HOT</sub> states, the Intel High Definition Audio controller's configuration space is available, but the I/O and memory space are not. Additionally, interrupts are blocked.</li> <li>3. When software changes this value from D3<sub>HOT</sub> state to the D0 state, an internal warm (soft) reset is generated, and software must re-initialize the function.</li> </ol>

### 17.1.26 MID—MSI Capability ID Register (Intel® High Definition Audio Controller—D27:F0)

Address Offset: 60h-61h                      Attribute: RO  
Default Value: 7005h                      Size: 16 bits

Bit	Description
15:8	Next Capability (Next) — RO. Hardwired to 70h. Points to the PCI Express* capability structure.
7:0	Cap ID (CAP) — RO. Hardwired to 05h. Indicates that this pointer is a MSI capability

### 17.1.27 MMC—MSI Message Control Register (Intel® High Definition Audio Controller—D27:F0)

Address Offset: 62h-63h                      Attribute: RO, R/W  
Default Value: 0080h                      Size: 16 bits

Bit	Description
15:8	Reserved
7	64b Address Capability (64ADD) — RO. Hardwired to 1. Indicates the ability to generate a 64-bit message address
6:4	Multiple Message Enable (MME) — RO. Normally this is a R/W register. However, since only 1 message is supported, these bits are hardwired to 000 = 1 message.
3:1	Multiple Message Capable (MMC) — RO. Hardwired to 0 indicating request for 1 message.
0	<p><b>MSI Enable (ME)</b> — R/W.</p> <p>0 = MSI may not be generated 1 = MSI will be generated instead of an INTx signal.</p>



### 17.1.28 MMLA—MSI Message Lower Address Register (Intel® High Definition Audio Controller—D27:F0)

Address Offset: 64h-67h                      Attribute:                      RO, R/W  
Default Value: 00000000h                      Size:                              32 bits

Bit	Description
31:2	<b>Message Lower Address (MLA)</b> — R/W. Lower address used for MSI message.
1:0	Reserved.

### 17.1.29 MMUA—MSI Message Upper Address Register (Intel® High Definition Audio Controller—D27:F0)

Address Offset: 68h-6Bh                      Attribute:                      R/W  
Default Value: 00000000h                      Size:                              32 bits

Bit	Description
31:0	<b>Message Upper Address (MUA)</b> — R/W. Upper 32-bits of address used for MSI message.

### 17.1.30 MMD—MSI Message Data Register (Intel® High Definition Audio Controller—D27:F0)

Address Offset: 6Ch-6Dh                      Attribute:                      R/W  
Default Value: 0000h                              Size:                              16 bits

Bit	Description
15:0	<b>Message Data (MD)</b> — R/W. Data used for MSI message.

### 17.1.31 PXID—PCI Express\* Capability ID Register (Intel® High Definition Audio Controller—D27:F0)

Address Offset: 70h-71h                      Attribute:                      RO  
Default Value: 0010h                              Size:                              16 bits

Bit	Description
15:8	<b>Next Capability (Next)</b> — RO. Hardwired to 0. Indicates that this is the last capability structure in the list.
7:0	<b>Cap ID (CAP)</b> — RO. Hardwired to 10h. Indicates that this pointer is a PCI Express* capability structure







### 17.1.34 DEVC—Device Control Register (Intel® High Definition Audio Controller—D27:F0)

Address Offset: 78h-79h                      Attribute: R/W, RO  
 Default Value: 0800h                      Size: 16 bits

Bit	Description
15	Reserved
14:12	Max Read Request Size — RO. Hardwired to 0 enabling 128B maximum read request size.
11	<p><b>No Snoop Enable (NSNPEN)</b> — R/W.</p> <p>0 = The Intel® High Definition Audio controller will not set the No Snoop bit. In this case, isochronous transfers will not use VC1 (VCi) even if it is enabled since VC1 is never snooped. Isochronous transfers will use VC0.</p> <p>1 = The Intel High Definition Audio controller is permitted to set the No Snoop bit in the Requester Attributes of a bus master transaction. In this case, VC0 or VC1 may be used for isochronous transfers.</p> <p><b>NOTE:</b> This bit is not reset on D3<sub>HOT</sub> to D0 transition; however, it is reset by PLTRST#.</p>
10	Auxiliary Power Enable — RO. Hardwired to 0, indicating that Intel High Definition Audio device does not draw AUX power
9	Phantom Function Enable — RO. Hardwired to 0 disabling phantom functions.
8	Extended Tag Field Enable — RO. Hardwired to 0 enabling 5-bit tag.
7:5	Max Payload Size — RO. Hardwired to 0 indicating 128B.
4	Enable Relaxed Ordering — RO. Hardwired to 0 disabling relaxed ordering.
3	Unsupported Request Reporting Enable — RO. Not implemented. Hardwired to 0.
2	Fatal Error Reporting Enable — RO. Not implemented. Hardwired to 0.
1	Non-Fatal Error Reporting Enable — RO. Not implemented. Hardwired to 0.
0	Correctable Error Reporting Enable — RO. Not implemented. Hardwired to 0.



### 17.1.35 DEVS—Device Status Register (Intel® High Definition Audio Controller—D27:F0)

Address Offset: 7Ah-7Bh                      Attribute:              RO  
 Default Value: 0010h                      Size:                      16 bits

Bit	Description
15:6	Reserved
5	Transactions Pending — RO. 0 = Completions for all non-posted requests have been received 1 = Intel® High Definition Audio controller has issued non-posted requests that have not been completed.
4	AUX Power Detected — RO. Hardwired to 1 indicating the device is connected to resume power
3	Unsupported Request Detected — RO. Not implemented. Hardwired to 0.
2	Fatal Error Detected — RO. Not implemented. Hardwired to 0.
1	Non-Fatal Error Detected — RO. Not implemented. Hardwired to 0.
0	Correctable Error Detected — RO. Not implemented. Hardwired to 0.

### 17.1.36 VCCAP—Virtual Channel Enhanced Capability Header (Intel® High Definition Audio Controller—D27:F0)

Address Offset: 100h-103h                      Attribute:              RO  
 Default Value: 13010002h                      Size:                      32 bits

Bit	Description
31:20	Next Capability Offset — RO. Hardwired to 130h. Points to the next capability header, which is the Root Complex Link Declaration Enhanced Capability Header.
19:16	Capability Version — RO. Hardwired to 1h.
15:0	PCI Express* Extended Capability — RO. Hardwired to 0002h.



### 17.1.37 PVCCAP1—Port VC Capability Register 1 (Intel® High Definition Audio Controller—D27:F0)

Address Offset: 104h-107h                      Attribute: RO  
Default Value: 00000001h                      Size: 32 bits

Bit	Description
31:12	Reserved.
11:10	Port Arbitration Table Entry Size — RO. Hardwired to 0 since this is an endpoint device.
9:8	Reference Clock — RO. Hardwired to 0 since this is an endpoint device.
7	Reserved.
6:4	Low Priority Extended VC Count — RO. Hardwired to 0. Indicates that only VC0 belongs to the low priority VC group
3	Reserved.
2:0	Extended VC Count — RO. Hardwired to 001b. Indicates that 1 extended VC (in addition to VC0) is supported by the Intel® High Definition Audio controller.

### 17.1.38 PVCCAP2 — Port VC Capability Register 2 (Intel® High Definition Audio Controller—D27:F0)

Address Offset: 108h-10Bh                      Attribute: RO  
Default Value: 00000000h                      Size: 32 bits

Bit	Description
31:24	VC Arbitration Table Offset — RO. Hardwired to 0 indicating that a VC arbitration table is not present.
23:8	Reserved.
7:0	VC Arbitration Capability — RO. Hardwired to 0. These bits are not applicable since the Intel® High Definition Audio controller reports a 0 in the Low Priority Extended VC Count bits in the PVCCAP1 register.

### 17.1.39 PVCCTL — Port VC Control Register (Intel® High Definition Audio Controller—D27:F0)

Address Offset: 10Ch-10Dh                      Attribute: RO  
Default Value: 0000h                              Size: 16 bits

Bit	Description
15:4	Reserved.
3:1	VC Arbitration Select — RO. Hardwired to 0. Normally these bits are R/W. However, these bits are not applicable since the Intel® High Definition Audio controller reports a 0 in the Low Priority Extended VC Count bits in the PVCCAP1 register.
0	Load VC Arbitration Table — RO. Hardwired to 0 since an arbitration table is not present.



### 17.1.40 PVCSTS—Port VC Status Register (Intel® High Definition Audio Controller—D27:F0)

Address Offset: 10Eh–10Fh                      Attribute: RO  
Default Value: 0000h                              Size: 16 bits

Bit	Description
15:1	Reserved.
0	VC Arbitration Table Status — RO. Hardwired to 0 since an arbitration table is not present.

### 17.1.41 VCOCAP—VCO Resource Capability Register (Intel® High Definition Audio Controller—D27:F0)

Address Offset: 110h–113h                      Attribute: RO  
Default Value: 00000000h                      Size: 32 bits

Bit	Description
31:24	Port Arbitration Table Offset — RO. Hardwired to 0 since this field is not valid for endpoint devices
23	Reserved.
22:16	Maximum Time Slots — RO. Hardwired to 0 since this field is not valid for endpoint devices
15	Reject Snoop Transactions — RO. Hardwired to 0 since this field is not valid for endpoint devices.
14	Advanced Packet Switching — RO. Hardwired to 0 since this field is not valid for endpoint devices
13:8	Reserved.
7:0	Port Arbitration Capability — RO. Hardwired to 0 since this field is not valid for endpoint devices

### 17.1.42 VCOCTL—VCO Resource Control Register (Intel® High Definition Audio Controller—D27:F0)

Address Offset: 114h–117h                      Attribute: R/W, RO  
Default Value: 800000FFh                      Size: 32 bits

Bit	Description
31	VCO Enable — RO. Hardwired to 1 for VCO.
30:27	Reserved.
26:24	VCO ID — RO. Hardwired to 0 since the first VC is always assigned as VCO.
23:20	Reserved.
19:17	Port Arbitration Select — RO. Hardwired to 0 since this field is not valid for endpoint devices.
16	Load Port Arbitration Table — RO. Hardwired to 0 since this field is not valid for endpoint devices.
15:8	Reserved.
7:0	<b>TC/VCO Map</b> — R/W, RO. Bit 0 is hardwired to 1 since TC0 is always mapped VCO. Bits 7:1 are implemented as R/W bits.



### 17.1.43 VCOSTS—VCO Resource Status Register (Intel® High Definition Audio Controller—D27:F0)

Address Offset: 11Ah–11Bh                      Attribute: RO  
Default Value: 0000h                              Size: 16 bits

Bit	Description
15:2	Reserved.
1	VCO Negotiation Pending — RO. Hardwired to 0 since this bit does not apply to the integrated Intel® High Definition Audio device.
0	Port Arbitration Table Status — RO. Hardwired to 0 since this field is not valid for endpoint devices.

### 17.1.44 VCiCAP—VCi Resource Capability Register (Intel® High Definition Audio Controller—D27:F0)

Address Offset: 11Ch–11Fh                      Attribute: RO  
Default Value: 00000000h                        Size: 32 bits

Bit	Description
31:24	Port Arbitration Table Offset — RO. Hardwired to 0 since this field is not valid for endpoint devices.
23	Reserved.
22:16	Maximum Time Slots — RO. Hardwired to 0 since this field is not valid for endpoint devices.
15	Reject Snoop Transactions — RO. Hardwired to 0 since this field is not valid for endpoint devices.
14	Advanced Packet Switching — RO. Hardwired to 0 since this field is not valid for endpoint devices.
13:8	Reserved
7:0	Port Arbitration Capability — RO. Hardwired to 0 since this field is not valid for endpoint devices.



### 17.1.45 VCICTL—VCi Resource Control Register (Intel® High Definition Audio Controller—D27:F0)

Address Offset: 120h–123h                      Attribute: R/W, RO  
 Default Value: 00000000h                      Size: 32 bits

Bit	Description
31	<b>VCi Enable</b> — R/W. 0 = Disabled 1 = Enabled  <b>NOTE:</b> This bit is not reset on D3 <sub>HOT</sub> to D0 transition; however, it is reset by PLTRST#.
30:27	Reserved.
26:24	<b>VCi ID</b> — R/W. This field assigns a VC ID to the VCi resource. This field is not used by the ICH8 hardware, but it is R/W to avoid confusing software.
23:20	Reserved.
19:17	Port Arbitration Select — RO. Hardwired to 0 since this field is not valid for endpoint devices
16	Load Port Arbitration Table — RO. Hardwired to 0 since this field is not valid for endpoint devices
15:8	Reserved.
7:0	<b>TC/VCi Map</b> — R/W, RO. This field indicates the TCs that are mapped to the VCi resource. Bit 0 is hardwired to 0 indicating that it cannot be mapped to VCi. Bits [7:1] are implemented as R/W bits. This field is not used by the ICH8 hardware, but it is R/W to avoid confusing software.

### 17.1.46 VCISTS—VCi Resource Status Register (Intel® High Definition Audio Controller—D27:F0)

Address Offset: 126h–127h                      Attribute: RO  
 Default Value: 0000h                              Size: 16 bits

Bit	Description
15:2	Reserved.
1	VCi Negotiation Pending — RO. Does not apply. Hardwired to 0.
0	Port Arbitration Table Status — RO. Hardwired to 0 since this field is not valid for endpoint devices.







### 17.1.50 L1ADDL—Link 1 Lower Address Register (Intel® High Definition Audio Controller—D27:F0)

Address Offset: 148h–14Bh      Attribute: RO  
 Default Value: See Register Description      Size: 32 bits

Bit	Description
31:14	Link 1 Lower Address — RO. Hardwired to match the RCBA register value in the PCI-LPC bridge (D31:F0:F0h).
13:0	Reserved.

### 17.1.51 L1ADDU—Link 1 Upper Address Register (Intel® High Definition Audio Controller—D27:F0)

Address Offset: 14Ch–14Fh      Attribute: RO  
 Default Value: 00000000h      Size: 32 bits

Bit	Description
31:0	Link 1 Upper Address — RO. Hardwired to 00000000h.



## 17.2 Intel® High Definition Audio Memory Mapped Configuration Registers (Intel® High Definition Audio— D27:F0)

The base memory location for these memory-mapped configuration registers is specified in the HDBAR register (D27:F0, offset 10h and D27:F0, offset 14h). The individual registers are then accessible at HDBAR + Offset as indicated in the following table.

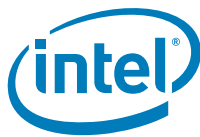
These memory-mapped registers must be accessed in byte, word, or DWord quantities.

**Table 140. Intel® High Definition Audio PCI Register Address Map (Intel® High Definition Audio D27:F0) (Sheet 1 of 4)**

HDBAR + Offset	Mnemonic	Register Name	Default	Access
00h–01h	GCAP	Global Capabilities	4401h	RO
02h	VMIN	Minor Version	00h	RO
03h	VMAJ	Major Version	01h	RO
04h–05h	OUTPAY	Output Payload Capability	003Ch	RO
06h–07h	INPAY	Input Payload Capability	001Dh	RO
08h–0Bh	GCTL	Global Control	00000000h	R/W
0Ch–0Dh	WAKEEN	Wake Enable	0000h	R/W
0Eh–0Fh	STATESTS	State Change Status	0000h	R/WC
10h–11h	GSTS	Global Status	0000h	R/WC
12h–13h	Rsv	Reserved	0000h	RO
14h–17h	ECAP	Extended Capabilities	00000001h	RO
18h–19h	OUTSTRMPAY	Output Stream Payload Capability	0030h	RO
1Ah–1Bh	INSTRMPAY	Input Stream Payload Capability	0018h	RO
1Ch–1Fh	Rsv	Reserved	00000000h	RO
20h–23h	INTCTL	Interrupt Control	00000000h	R/W
24h–27h	INTSTS	Interrupt Status	00000000h	RO
30h–33h	WALCLK	Wall Clock Counter	00000000h	RO
34h–37h	SSYNC	Stream Synchronization	00000000h	R/W
40h–43h	CORBLOWER	CORB Lower Base Address	00000000h	R/W, RO
44h–47h	CORBUPPER	CORB Upper Base Address	00000000h	R/W
48h–49h	CORBWP	CORB Write Pointer	0000h	R/W
4Ah–4Bh	CORBWP	CORB Read Pointer	0000h	R/W
4Ch	CORBCTL	CORB Control	00h	R/W
4Dh	CORBST	CORB Status	00h	R/WC
4Eh	CORBSize	CORB Size	42h	RO
50h–53h	RIRBLLOWER	RIRB Lower Base Address	00000000h	R/W, RO
54h–57h	RIRBUPPER	RIRB Upper Base Address	00000000h	R/W
58h–59h	RIRBWP	RIRB Write Pointer	0000h	R/W, RO


**Table 140. Intel® High Definition Audio PCI Register Address Map (Intel® High Definition Audio D27:F0) (Sheet 2 of 4)**

HDBAR + Offset	Mnemonic	Register Name	Default	Access
5Ah–5Bh	RINTCNT	Response Interrupt Count	0000h	R/W
5Ch	RIRBCTL	RIRB Control	00h	R/W
5Dh	RIRBSTS	RIRB Status	00h	R/WC
5Eh	RIRBSIZE	RIRB Size	42h	RO
60h–63h	IC	Immediate Command	00000000h	R/W
64h–67h	IR	Immediate Response	00000000h	RO
68h–69h	IRS	Immediate Command Status	0000h	R/W, R/WC
70h–73h	DPLBASE	DMA Position Lower Base Address	00000000h	R/W, RO
74h–77h	DPUBASE	DMA Position Upper Base Address	00000000h	R/W
80–82h	ISD0CTL	Input Stream Descriptor 0 (ISD0) Control	040000h	R/W, RO
83h	ISD0STS	ISD0 Status	00h	R/WC, RO
84h–87h	ISD0LPIB	ISD0 Link Position in Buffer	00000000h	RO
88h–8Bh	ISD0CBL	ISD0 Cyclic Buffer Length	00000000h	R/W
8Ch–8Dh	ISD0LVI	ISD0 Last Valid Index	0000h	R/W
8Eh–8F	ISD0FIFOW	ISD0 FIFO Watermark	0004h	R/W
90h–91h	ISD0FIFOS	ISD0 FIFO Size	0077h	RO
92h–93h	ISD0FMT	ISD0 Format	0000h	R/W
98h–9Bh	ISD0BDPL	ISD0 Buffer Descriptor List Pointer-Lower Base Address	00000000h	R/W, RO
9Ch–9Fh	ISD0BDPU	ISD0 Buffer Description List Pointer-Upper Base Address	00000000h	R/W
A0h–A2h	ISD1CTL	Input Stream Descriptor 1 (ISD01) Control	040000h	R/W, RO
A3h	ISD1STS	ISD1 Status	00h	R/WC, RO
A4h–A7h	ISD1LPIB	ISD1 Link Position in Buffer	00000000h	RO
A8h–ABh	ISD1CBL	ISD1 Cyclic Buffer Length	00000000h	R/W
ACH–ADh	ISD1LVI	ISD1 Last Valid Index	0000h	R/W
AEh–AFh	ISD1FIFOW	ISD1 FIFO Watermark	0004h	R/W
B0h–B1h	ISD1FIFOS	ISD1 FIFO Size	0077h	RO
B2h–B3h	ISD1FMT	ISD1 Format	0000h	R/W
B8h–BBh	ISD1BDPL	ISD1 Buffer Descriptor List Pointer-Lower Base Address	00000000h	R/W, RO
BCh–BFh	ISD1BDPU	ISD1 Buffer Description List Pointer-Upper Base Address	00000000h	R/W
C0h–C2h	ISD2CTL	Input Stream Descriptor 2 (ISD2) Control	040000h	R/W, RO
C3h	ISD2STS	ISD2 Status	00h	R/WC, RO



**Table 140. Intel® High Definition Audio PCI Register Address Map (Intel® High Definition Audio D27:F0) (Sheet 3 of 4)**

HDBAR + Offset	Mnemonic	Register Name	Default	Access
C4h–C7h	ISD2LPIB	ISD2 Link Position in Buffer	00000000h	RO
C8h–CBh	ISD2CBL	ISD2 Cyclic Buffer Length	00000000h	R/W
CCh–CDh	ISD2LVI	ISD2 Last Valid Index	0000h	R/W
CEh–CFh	ISD1FIFOW	ISD1 FIFO Watermark	0004h	R/W
D0h–D1h	ISD2FIFOS	ISD2 FIFO Size	0077h	RO
D2h–D3h	ISD2FMT	ISD2 Format	0000h	R/W
D8h–DBh	ISD2BDPL	ISD2 Buffer Descriptor List Pointer-Lower Base Address	00000000h	R/W, RO
DCh–DFh	ISD2BDPU	ISD2 Buffer Description List Pointer-Upper Base Address	00000000h	R/W
E0h–E2h	ISD3CTL	Input Stream Descriptor 3 (ISD3) Control	040000h	R/W, RO
E3h	ISD3STS	ISD3 Status	00h	R/WC, RO
E4h–E7h	ISD3LPIB	ISD3 Link Position in Buffer	00000000h	RO
E8h–EBh	ISD3CBL	ISD3 Cyclic Buffer Length	00000000h	R/W
ECh–EDh	ISD3LVI	ISD3 Last Valid Index	0000h	R/W
EEh–EFh	ISD3FIFOW	ISD3 FIFO Watermark	0004h	R/W
F0h–F1h	ISD3FIFOS	ISD3 FIFO Size	0077h	RO
F2h–F3h	ISD3FMT	ISD3 Format	0000h	R/W
F8h–FBh	ISD3BDPL	ISD3 Buffer Descriptor List Pointer-Lower Base Address	00000000h	R/W, RO
FCh–FFh	ISD3BDPU	ISD3 Buffer Description List Pointer-Upper Base Address	00000000h	R/W
100h–102h	OSD0CTL	Output Stream Descriptor 0 (OSD0) Control	040000h	R/W, RO
103h	OSD0STS	OSD0 Status	00h	R/WC, RO
104h–107h	OSD0LPIB	OSD0 Link Position in Buffer	00000000h	RO
108h–10Bh	OSD0CBL	OSD0 Cyclic Buffer Length	00000000h	R/W
10Ch–10Dh	OSD0LVI	OSD0 Last Valid Index	0000h	R/W
10Eh–10Fh	OSD0FIFOW	OSD0 FIFO Watermark	0004h	R/W
110h–111h	OSD0FIFOS	OSD0 FIFO Size	00BFh	R/W
112h–113h	OSD0FMT	OSD0 Format	0000h	R/W
118h–11Bh	OSD0BDPL	OSD0 Buffer Descriptor List Pointer-Lower Base Address	00000000h	R/W, RO
11Ch–11Fh	OSD0BDPU	OSD0 Buffer Description List Pointer-Upper Base Address	00000000h	R/W
120h–122h	OSD1CTL	Output Stream Descriptor 1 (OSD1) Control	040000h	R/W, RO
123h	OSD1STS	OSD1 Status	00h	R/WC, RO


**Table 140. Intel® High Definition Audio PCI Register Address Map (Intel® High Definition Audio D27:F0) (Sheet 4 of 4)**

HDBAR + Offset	Mnemonic	Register Name	Default	Access
124h–127h	OSD1LPIB	OSD1 Link Position in Buffer	00000000h	RO
128h–12Bh	OSD1CBL	OSD1 Cyclic Buffer Length	00000000h	R/W
12Ch–12Dh	OSD1LVI	OSD1 Last Valid Index	0000h	R/W
12Eh–12Fh	OSD1FIFOW	OSD1 FIFO Watermark	0004h	R/W
130h–131h	OSD1FIFOS	OSD1 FIFO Size	00BFh	R/W
132h–133h	OSD1FMT	OSD1 Format	0000h	R/W
138h–13Bh	OSD1BDPL	OSD1 Buffer Descriptor List Pointer-Lower Base Address	00000000h	R/W, RO
13Ch–13Fh	OSD1BDPU	OSD1 Buffer Description List Pointer-Upper Base Address	00000000h	R/W
140h–142h	OSD2CTL	Output Stream Descriptor 2 (OSD2) Control	040000h	R/W, RO
143h	OSD2STS	OSD2 Status	00h	R/WC, RO
144h–147h	OSD2LPIB	OSD2 Link Position in Buffer	00000000h	RO
148h–14Bh	OSD2CBL	OSD2 Cyclic Buffer Length	00000000h	R/W
14Ch–14Dh	OSD2LVI	OSD2 Last Valid Index	0000h	R/W
14Eh–14Fh	OSD2FIFOW	OSD2 FIFO Watermark	0004h	R/W
150h–151h	OSD2FIFOS	OSD2 FIFO Size	00BFh	R/W
152h–153h	OSD2FMT	OSD2 Format	0000h	R/W
158h–15Bh	OSD2BDPL	OSD2 Buffer Descriptor List Pointer-Lower Base Address	00000000h	R/W, RO
15Ch–15Fh	OSD2BDPU	OSD2 Buffer Description List Pointer-Upper Base Address	00000000h	R/W
160h–162h	OSD3CTL	Output Stream Descriptor 3 (OSD3) Control	040000h	R/W, RO
163h	OSD3STS	OSD3 Status	00h	R/WC, RO
164h–167h	OSD3LPIB	OSD3 Link Position in Buffer	00000000h	RO
168h–16Bh	OSD3CBL	OSD3 Cyclic Buffer Length	00000000h	R/W
16Ch–16Dh	OSD3LVI	OSD3 Last Valid Index	0000h	R/W
16Eh–16Fh	OSD3FIFOW	OSD3 FIFO Watermark	0004h	R/W
170h–171h	OSD3FIFOS	OSD3 FIFO Size	00BFh	R/W
172h–173h	OSD3FMT	OSD3 Format	0000h	R/W
178h–17Bh	OSD3BDPL	OSD3 Buffer Descriptor List Pointer-Lower Base Address	00000000h	R/W, RO
17Ch–17Fh	OSD3BDPU	OSD3 Buffer Description List Pointer-Upper Base Address	00000000h	R/W



### 17.2.1 GCAP—Global Capabilities Register (Intel® High Definition Audio Controller—D27:F0)

Memory Address: HDBAR + 00h                      Attribute:                      RO  
Default Value: 4401h                                  Size:                                  16 bits

Bit	Description
15:12	Number of Output Stream Supported — RO. Hardwired to 0100b indicating that the ICH8 Intel® High Definition Audio controller supports 4 output streams.
11:8	Number of Input Stream Supported — RO. Hardwired to 0100b indicating that the ICH8 Intel High Definition Audio controller supports 4 input streams.
7:3	Number of Bidirectional Stream Supported — RO. Hardwired to 0 indicating that the ICH8 Intel High Definition Audio controller supports 0 bidirectional stream.
2	Reserved.
1	Number of Serial Data Out Signals — RO. Hardwired to 0 indicating that the ICH8 Intel High Definition Audio controller supports 1 serial data output signal.
0	64-bit Address Supported — RO. Hardwired to 1b indicating that the ICH8 Intel High Definition Audio controller supports 64-bit addressing for BDL addresses, data buffer addressees, and command buffer addresses.

### 17.2.2 VMIN—Minor Version Register (Intel® High Definition Audio Controller—D27:F0)

Memory Address: HDBAR + 02h                      Attribute:                      RO  
Default Value: 00h                                      Size:                                      8 bits

Bit	Description
7:0	Minor Version — RO. Hardwired to 0 indicating that the Intel® ICH8 supports minor revision number 00h of the Intel® High Definition Audio specification.

### 17.2.3 VMAJ—Major Version Register (Intel® High Definition Audio Controller—D27:F0)

Memory Address: HDBAR + 03h                      Attribute:                      RO  
Default Value: 01h                                      Size:                                      8 bits

Bit	Description
7:0	Major Version — RO. Hardwired to 01h indicating that the Intel® ICH8 supports major revision number 1 of the Intel® High Definition Audio specification.



## 17.2.4 OUTPAY—Output Payload Capability Register (Intel® High Definition Audio Controller—D27:F0)

Memory Address: HDBAR + 04h  
Default Value: 003Ch

Attribute: RO  
Size: 16 bits

Bit	Description
15:7	Reserved.
6:0	<p>Output Payload Capability — RO. Hardwired to 3Ch indicating 60 word payload. This field indicates the total output payload available on the link. This does not include bandwidth used for command and control. This measurement is in 16-bit word quantities per 48 MHz frame. The default link clock of 24.000 MHz (the data is double pumped) provides 1000 bits per frame, or 62.5 words in total. 40 bits are used for command and control, leaving 60 words available for data payload.</p> <p>00h = 0 word 01h = 1 word payload. ..... FFh = 256 word payload.</p>

## 17.2.5 INPAY—Input Payload Capability Register (Intel® High Definition Audio Controller—D27:F0)

Memory Address: HDBAR + 06h  
Default Value: 001Dh

Attribute: RO  
Size: 16 bits

Bit	Description
15:7	Reserved.
6:0	<p>Input Payload Capability — RO. Hardwired to 1Dh indicating 29 word payload. This field indicates the total output payload available on the link. This does not include bandwidth used for response. This measurement is in 16-bit word quantities per 48 MHz frame. The default link clock of 24.000 MHz provides 500 bits per frame, or 31.25 words in total. 36 bits are used for response, leaving 29 words available for data payload.</p> <p>00h = 0 word 01h = 1 word payload. ..... FFh = 256 word payload.</p>



### 17.2.6 GCTL—Global Control Register (Intel® High Definition Audio Controller—D27:F0)

Memory Address: HDBAR + 08h                      Attribute:                      R/W  
 Default Value: 00000000h                      Size:                      32 bits

Bit	Description
31:9	Reserved.
8	<p><b>Accept Unsolicited Response Enable</b> — R/W.</p> <p>0 = Unsolicited responses from the codecs are not accepted.            1 = Unsolicited response from the codecs are accepted by the controller and placed into the Response Input Ring Buffer.</p>
7:2	Reserved.
1	<p><b>Flush Control</b> — R/W. Writing a 1 to this bit initiates a flush. When the flush completion is received by the controller, hardware sets the Flush Status bit and clears this Flush Control bit. Before a flush cycle is initiated, the DMA Position Buffer must be programmed with a valid memory address by software, but the DMA Position Buffer bit 0 needs not be set to enable the position reporting mechanism. Also, all streams must be stopped (the associated RUN bit must be 0).</p> <p>When the flush is initiated, the controller will flush the pipelines to memory to assure that the hardware is ready to transition to a D3 state. Setting this bit is not a critical step in the power state transition if the content of the FIFOs is not critical.</p>
0	<p><b>Controller Reset #</b> — R/W.</p> <p>0 = Writing a 0 resets the Intel High Definition Audio controller. All state machines, FIFOs and non-resume well memory mapped configuration registers (not PCI configuration registers) in the controller will be reset. The Intel High Definition Audio link RESET# signal will be asserted, and all other link signals will be driven to their default values. After the hardware has completed sequencing into the reset state, it will report a 0 in this bit. Software must read a 0 from this bit to verify the controller is in reset.</p> <p>1 = Writing a 1 causes the controller to exit its reset state and de-assert the Intel High Definition Audio link RESET# signal. Software is responsible for setting/clearing this bit such that the minimum Intel High Definition Audio link RESET# signal assertion pulse width specification is met. When the controller hardware is ready to begin operation, it will report a 1 in this bit. Software must read a 1 from this bit before accessing any controller registers. This bit defaults to a 0 after Hardware reset, therefore, software needs to write a 1 to this bit to begin operation.</p> <p><b>NOTES:</b></p> <ol style="list-style-type: none"> <li>The CORB/RIRB RUN bits and all stream RUN bits must be verified cleared to 0 before writing a 0 to this bit in order to assure a clean re-start.</li> <li>When setting or clearing this bit, software must ensure that minimum link timing requirements (minimum RESET# assertion time, etc.) are met.</li> <li>When this bit is 0 indicating that the controller is in reset, writes to all Intel High Definition Audio memory mapped registers are ignored as if the device is not present. The only exception is this register itself. The Global Control register is write-able as a DWord, Word, or Byte even when CRST# (this bit) is 0 if the byte enable for the byte containing the CRST# bit (Byte Enable 0) is active. If Byte Enable 0 is not active, writes to the Global Control register will be ignored when CRST# is 0. When CRST# is 0, reads to Intel High Definition Audio memory mapped registers will return their default value except for registers that are not reset with PLTRST# or on a D3HOT to D0 transition.</li> </ol>





### 17.2.7 WAKEEN—Wake Enable Register (Intel® High Definition Audio Controller—D27:F0)

Memory Address: HDBAR + 0Ch  
Default Value: 0000h

Attribute: R/W  
Size: 16 bits

Bit	Description
15:4	Reserved.
3:0	<p><b>SDIN Wake Enable Flags</b> — R/W. These bits control which SDI signal(s) may generate a wake event. A 1b in the bit mask indicates that the associated SDIN signal is enabled to generate a wake.</p> <p>Bit 0 is used for SDI[0] Bit 1 is used for SDI[1] Bit 2 is used for SDI[2] Bit 3 is used for SDI[3]</p> <p><b>NOTE:</b> These bits are in the resume well and only cleared on a power on reset. Software must not make assumptions about the reset state of these bits and must set them appropriately.</p>

### 17.2.8 STATESTS—State Change Status Register (Intel® High Definition Audio Controller—D27:F0)

Memory Address: HDBAR + 0Eh  
Default Value: 0000h

Attribute: R/WC  
Size: 16 bits

Bit	Description
15:4	Reserved.
3:0	<p><b>SDIN State Change Status Flags</b> — R/WC. Flag bits that indicate which SDI signal(s) received a state change event. The bits are cleared by writing 1's to them.</p> <p>Bit 0 = SDI[0] Bit 1 = SDI[1] Bit 2 = SDI[2] Bit 3 = SDI[3]</p> <p><b>NOTE:</b> These bits are in the resume well and only cleared on a power on reset. Software must not make assumptions about the reset state of these bits and must set them appropriately.</p>



### 17.2.9 GSTS—Global Status Register (Intel® High Definition Audio Controller—D27:F0)

Memory Address: HDBAR + 10h  
Default Value: 0000h

Attribute: R/WC  
Size: 16 bits

Bit	Description
15:4	Reserved.
3 (Mobile Only)	<b>Dock Mated Interrupt Status (DMIS)</b> — R/W/C. A 1 indicates that the dock mating or unmating process has completed. For the docking process it indicates that dock is electrically connected and that software may detect and enumerate the docked codecs. For the undocking process it indicates that the dock is electrically isolated and that software may report to the user that physical undocking may commence. This bit gets set to a 1 by hardware when the DM bit transitions from a 0 to a 1 (docking) or from a 1 to a 0 (undocking). Note that this bit is set regardless of the state of the DMIE bit. Software clears this bit by writing a 1 to it. Writing a 0 to this bit has no affect.
3 (Desktop Only)	Reserved
2 (Mobile Only)	<b>Dock Mated (DM)</b> —RO. This bit effectively communicates to software that an Intel® HD Audio docked codec is physically and electrically attached. Controller hardware sets this bit to 1 after the docking sequence triggered by writing a 1 to the Dock Attach (GCTL.DA) bit is completed (HDA_DOCK_RST# deassertion). This bit indicates to software that the docked codec(s) may be discovered via the STATESTS register and then enumerated. Controller hardware sets this bit to 0 after the undocking sequence triggered by writing a 0 to the Dock Attach (GCTL.DA) bit is completed (DOCK_EN# deasserted). This bit indicates to software that the docked codec(s) may be physically undocked. This bit is Read Only. Writes to this bit have no effect.
2 (Desktop Only)	Reserved
1	<b>Flush Status</b> — R/WC. This bit is set to 1 by hardware to indicate that the flush cycle initiated when the Flush Control bit (HDBAR + 08h, bit 1) was set has completed. Software must write a 1 to clear this bit before the next time the Flush Control bit is set to clear the bit.
0	Reserved.



### 17.2.10 ECAP—Extended Capabilities (Intel® High Definition Audio Controller—D27:F0)

Memory Address: HDBAR + 14h                      Attribute:                      R/WO  
 Default Value: 0000001h                      Size:                      32 bits

Bit	Description
31:1	Reserved
0	<p><b>Docking Supported (DS)</b>— R/WO. A 1 indicates that Intel® ICH8 supports Intel® HD Audio Docking. The GCTL.DA bit is only writable when this DS bit is 1. Intel HD Audio driver software should only branch to its docking routine when this DS bit is 1. BIOS may clear this bit to 0 to prohibit the Intel HD Audio driver software from attempting to run the docking routines.</p> <p>Note that this bit is reset to its default value only on a PLTRST#, but not on a CRST# or D3<sub>hot</sub>-to-D0 transition.</p>

### 17.2.11 OUTSTRMPAY—Output Stream Payload Capability (Intel® High Definition Audio Controller—D27:F0)

Memory Address: HDBAR + 18h                      Attribute:                      RO  
 Default Value: 0030h                      Size:                      16 bits

Bit	Description
15:14	<p><b>Output FIFO Padding Type (OPADTYPE)</b>— RO. This field indicates how the controller pads the samples in the controller's buffer (FIFO). Controllers may not pad at all or may pad to byte or memory container sizes.</p> <p>0h = Controller pads all samples to bytes            1h = Reserved            2h = Controller pads to memory container size            3h = Controller does not pad and uses samples directly</p>
13:0	<p><b>Output Stream Payload Capability (OUTSTRMPAY)</b>— RO. This field indicates maximum number of words per frame for any single output stream. This measurement is in 16-bit word quantities per 48 kHz frame. The maximum supported is 48 Words (96B); therefore, a value of 30h is reported in this register. The value does not specify the number of words actually transmitted in the frame, but is the size of the data in the controller buffer (FIFO) after the samples are padded as specified by OPADTYPE. Thus, to compute the supported streams, each sample is padded according to OPADTYPE and then multiplied by the number of channels and samples per frame. If this computed value is larger than OUTSTRMPAY, then that stream is not supported. The value specified is not affected by striping.</p> <p>Software must ensure that a format which would cause more Words per frame than indicated is not programmed into the Output Stream Descriptor Register.</p> <p>The value may be larger than the OUTPAY register value in some cases.</p>



### 17.2.12 INSTRMPAY—Input Stream Payload Capability (Intel® High Definition Audio Controller—D27:F0)

Memory Address: HDBAR + 1Ah                      Attribute:                      RO  
Default Value: 0018h                              Size:                              16 bits

Bit	Description
15:14	<p><b>Input FIFO Padding Type (IPADTYPE)</b>— RO. This field indicates how the controller pads the samples in the controller's buffer (FIFO). Controllers may not pad at all or may pad to byte or memory container sizes.</p> <p>0h = Controller pads all samples to bytes 1h = Reserved 2h = Controller pads to memory container size 3h = Controller does not pad and uses samples directly</p>
13:0	<p><b>Input Stream Payload Capability (INSTRMPAY)</b>— RO. This field indicates the maximum number of Words per frame for any single input stream. This measurement is in 16-bit Word quantities per 48-kHz frame. The maximum supported is 24 Words (48B); therefore, a value of 18h is reported in this register.</p> <p>The value does not specify the number of words actually transmitted in the frame, but is the size of the data as it will be placed into the controller's buffer (FIFO). Thus samples will be padded according to IPADTYPE before being stored into controller buffer. To compute the supported streams, each sample is padded according to IPADTYPE and then multiplied by the number of channels and samples per frame. If this computed value is larger than INSTRMPAY then that stream is not supported. As the inbound stream tag is not stored with the samples it is not included in the word count.</p> <p>The value may be larger than INPAY register value in some cases, although values less than INPAY may also be invalid due to overhead. Software must ensure that a format which would cause more Words per frame than indicated is not programmed into the Input Stream Descriptor Register.</p>



### 17.2.13 INTCTL—Interrupt Control Register (Intel® High Definition Audio Controller—D27:F0)

Memory Address: HDBAR + 20h  
Default Value: 00000000h

Attribute: R/W  
Size: 32 bits

Bit	Description
31	<p><b>Global Interrupt Enable (GIE)</b> — R/W. Global bit to enable device interrupt generation. When set to 1, the Intel® High Definition Audio function is enabled to generate an interrupt. This control is in addition to any bits in the bus specific address space, such as the Interrupt Enable bit in the PCI configuration space.</p> <p>0 = Disable 1 = Enable</p> <p><b>NOTE:</b> This bit is not affected by the D3<sub>HOT</sub> to D0 transition.</p>
30	<p><b>Controller Interrupt Enable (CIE)</b> — R/W. Enables the general interrupt for controller functions.</p> <p>When set to 1, the controller generates an interrupt when the corresponding status bit gets set due to a Response Interrupt, a Response Buffer Overrun, and State Change events.</p> <p><b>NOTE:</b> This bit is not affected by the D3<sub>HOT</sub> to D0 transition.</p>
29:8	Reserved
7:0	<p><b>Stream Interrupt Enable (SIE)</b> — R/W. When set to 1, the individual streams are enabled to generate an interrupt when the corresponding status bits get set.</p> <p>A stream interrupt will be caused as a result of a buffer with IOC = 1 in the BDL entry being completed, or as a result of a FIFO error (underrun or overrun) occurring. Control over the generation of each of these sources is in the associated Stream Descriptor.</p> <p>The streams are numbered and the SIE bits assigned sequentially, based on their order in the register set.</p> <p>Bit 0: input stream 1 Bit 1: input stream 2 Bit 2: input stream 3 Bit 3: input stream 4 Bit 4: output stream 1 Bit 5: output stream 2 Bit 6: output stream 3 Bit 7: output stream 4</p>



### 17.2.14 INTSTS—Interrupt Status Register (Intel® High Definition Audio Controller—D27:F0)

Memory Address: HDBAR + 24h  
Default Value: 00000000h

Attribute: RO  
Size: 32 bits

Bit	Description
31	<p>Global Interrupt Status (GIS) — RO. This bit is an OR of all the interrupt status bits in this register.</p> <p><b>NOTE:</b> This bit is not affected by the D3<sub>HOT</sub> to D0 transition.</p>
30	<p><b>Controller Interrupt Status (CIS)</b> — RO. Status of general controller interrupt.</p> <p>1 = Interrupt condition occurred due to a Response Interrupt, a Response Buffer Overrun Interrupt, or a SDIN State Change event. The exact cause can be determined by interrogating other registers. This bit is an OR of all of the stated interrupt status bits for this register.</p> <p><b>NOTES:</b></p> <ol style="list-style-type: none"> <li>This bit is set regardless of the state of the corresponding interrupt enable bit, but a hardware interrupt will not be generated unless the corresponding enable bit is set.</li> <li>This bit is not affected by the D3<sub>HOT</sub> to D0 transition.</li> </ol>
29:8	Reserved
7:0	<p><b>Stream Interrupt Status (SIS)</b> — RO.</p> <p>1 = Interrupt condition occurred on the corresponding stream. This bit is an OR of all of the stream's interrupt status bits.</p> <p><b>NOTE:</b> These bits are set regardless of the state of the corresponding interrupt enable bits.</p> <p>The streams are numbered and the SIE bits assigned sequentially, based on their order in the register set.</p> <p>Bit 0: input stream 1 Bit 1: input stream 2 Bit 2: input stream 3 Bit 3: input stream 4 Bit 4: output stream 1 Bit 5: output stream 2 Bit 6: output stream 3 Bit 7: output stream 4</p>



### 17.2.15 WALCLK—Wall Clock Counter Register (Intel® High Definition Audio Controller—D27:F0)

Memory Address: HDBAR + 30h  
Default Value: 00000000h

Attribute: RO  
Size: 32 bits

Bit	Description
31:0	<p>Wall Clock Counter — RO. This field provides results from a 32 bit counter that is incremented on each link BCLK period and rolls over from FFFF FFFFh to 0000 0000h. This counter will roll over to 0 with a period of approximately 179 seconds.</p> <p>This counter is enabled while the BCLK bit is set to 1. Software uses this counter to synchronize between multiple controllers. Will be reset on controller reset.</p>

### 17.2.16 SSYNC—Stream Synchronization Register (Intel® High Definition Audio Controller—D27:F0)

Memory Address: HDBAR + 34h  
Default Value: 00000000h

Attribute: R/W  
Size: 32 bits

Bit	Description
31:8	Reserved
7:0	<p><b>Stream Synchronization (SSYNC)</b> — R/W. When set to 1, these bits block data from being sent on or received from the link. Each bit controls the associated stream descriptor (i.e., bit 0 corresponds to the first stream descriptor, etc.)</p> <p>To synchronously start a set of DMA engines, these bits are first set to 1. The RUN bits for the associated stream descriptors are then set to 1 to start the DMA engines. When all streams are ready (FIFORDY =1), the associated SSYNC bits can all be set to 0 at the same time, and transmission or reception of bits to or from the link will begin together at the start of the next full link frame.</p> <p>To synchronously stop the streams, first these bits are set, and then the individual RUN bits in the stream descriptor are cleared by software.</p> <p>If synchronization is not desired, these bits may be left as 0, and the stream will simply begin running normally when the stream's RUN bit is set.</p> <p>The streams are numbered and the SIE bits assigned sequentially, based on their order in the register set.</p> <p>Bit 0: input stream 1 Bit 1: input stream 2 Bit 2: input stream 3 Bit 3: input stream 4 Bit 4: output stream 1</p>



### 17.2.17 CORBLBASE—CORB Lower Base Address Register (Intel® High Definition Audio Controller—D27:F0)

Memory Address: HDBAR + 40h                      Attribute:                      R/W, RO  
Default Value: 00000000h                      Size:                              32 bits

Bit	Description
31:7	<b>CORB Lower Base Address</b> — R/W. This field provides the lower address of the Command Output Ring Buffer, allowing the CORB base address to be assigned on any 128-B boundary. This register field must not be written when the DMA engine is running or the DMA transfer may be corrupted.
6:0	<b>CORB Lower Base Unimplemented Bits</b> — RO. Hardwired to 0. This required the CORB to be allocated with 128B granularity to allow for cache line fetch optimizations.

### 17.2.18 CORBUBASE—CORB Upper Base Address Register (Intel® High Definition Audio Controller—D27:F0)

Memory Address: HDBAR + 44h                      Attribute:                      R/W  
Default Value: 00000000h                      Size:                              32 bits

Bit	Description
31:0	<b>CORB Upper Base Address</b> — R/W. This field provides the upper 32 bits of the address of the Command Output Ring buffer. This register field must not be written when the DMA engine is running or the DMA transfer may be corrupted.

### 17.2.19 CORBWP—CORB Write Pointer Register (Intel® High Definition Audio Controller—D27:F0)

Memory Address: HDBAR + 48h                      Attribute:                      R/W  
Default Value: 0000h                              Size:                              16 bits

Bit	Description
15:8	Reserved.
7:0	<b>CORB Write Pointer</b> — R/W. Software writes the last valid CORB entry offset into this field in DWord granularity. The DMA engine fetches commands from the CORB until the Read pointer matches the Write pointer; supports 256 CORB entries (256x4B = 1 KB). This register field may be written when the DMA engine is running.





### 17.2.20 CORBRP—CORB Read Pointer Register (Intel® High Definition Audio Controller—D27:F0)

Memory Address: HDBAR + 4Ah  
Default Value: 0000h

Attribute: R/W  
Size: 16 bits

Bit	Description
15	<b>CORB Read Pointer Reset</b> — R/W. Software writes a 1 to this bit to reset the CORB Read Pointer to 0 and clear any residual prefetched commands in the CORB hardware buffer within the High Definition Audio controller. The hardware will physically update this bit to 1 when the CORB Pointer reset is complete. Software must read a 1 to verify that the reset completed correctly. Software must clear this bit back to 0 and read back the 0 to verify that the clear completed correctly. The CORB DMA engine must be stopped prior to resetting the Read Pointer or else DMA transfer may be corrupted.
14:8	Reserved.
7:0	CORB Read Pointer (CORBRP)— RO. Software reads this field to determine how many commands it can write to the CORB without over-running. The value read indicates the CORB Read Pointer offset in DWord granularity. The offset entry read from this field has been successfully fetched by the DMA controller and may be over-written by software; supports 256 CORB entries (256 x 4B=1KB). This field may be read while the DMA engine is running.

### 17.2.21 CORBCTL—CORB Control Register (Intel® High Definition Audio Controller—D27:F0)

Memory Address: HDBAR + 4Ch  
Default Value: 00h

Attribute: R/W  
Size: 8 bits

Bit	Description
7:2	Reserved.
1	<b>Enable CORB DMA Engine</b> — R/W. After software writes a 0 to this bit, the hardware may not stop immediately. The hardware will physically update the bit to 0 when the DMA engine is truly stopped. Software must read a 0 from this bit to verify that the DMA engine is truly stopped. 0 = DMA stop 1 = DMA run
0	<b>CORB Memory Error Interrupt Enable</b> — R/W. 0 = Disable 1 = Enable. The controller will generate an interrupt if the CMEI status bit (HDBAR + 4Dh: bit 0) is set.



### 17.2.22 CORBST—CORB Status Register (Intel® High Definition Audio Controller—D27:F0)

Memory Address: HDBAR + 4Dh                      Attribute:                      R/WC  
 Default Value: 00h                                      Size:                                8 bits

Bit	Description
7:1	Reserved.
0	<p><b>CORB Memory Error Indication (CMEI)</b> — R/WC. Software can clear this bit by writing a 1 to it. However, this type of error leaves the audio subsystem in an un-viable state and typically required a controller reset by writing a 0 to the Controller Reset # bit (HDBAR + 08h: bit 0).</p> <p>0 = Error Not detected.            1 = Controller has detected an error in the path way between the controller and memory. This may be an ECC bit error or any other type of detectable data error which renders the command data fetched invalid.</p>

### 17.2.23 CORBSIZE—CORB Size Register Intel® High Definition Audio Controller—D27:F0)

Memory Address: HDBAR + 4Eh                      Attribute:                      RO  
 Default Value: 42h                                      Size:                                8 bits

Bit	Description
7:4	CORB Size Capability — RO. Hardwired to 0100b indicating that the ICH8 only supports a CORB size of 256 CORB entries (1024B).
3:2	Reserved.
1:0	CORB Size — RO. Hardwired to 10b which sets the CORB size to 256 entries (1024B).

### 17.2.24 RIRBLBASE—RIRB Lower Base Address Register (Intel® High Definition Audio Controller—D27:F0)

Memory Address: HDBAR + 50h                      Attribute:                      R/W, RO  
 Default Value: 00000000h                              Size:                                32 bits

Bit	Description
31:7	<b>CORB Lower Base Address</b> — R/W. This field provides the lower address of the Response Input Ring Buffer, allowing the RIRB base address to be assigned on any 128-B boundary. This register field must not be written when the DMA engine is running or the DMA transfer may be corrupted.
6:0	RIRB Lower Base Unimplemented Bits — RO. Hardwired to 0. This required the RIRB to be allocated with 128-B granularity to allow for cache line fetch optimizations.



### 17.2.25 RIRBUBASE—RIRB Upper Base Address Register (Intel® High Definition Audio Controller—D27:F0)

Memory Address: HDBAR + 54h                      Attribute:                      R/W  
 Default Value: 00000000h                      Size:                              32 bits

Bit	Description
31:0	<b>RIRB Upper Base Address</b> — R/W. This field provides the upper 32 bits of the address of the Response Input Ring Buffer. This register field must not be written when the DMA engine is running or the DMA transfer may be corrupted.

### 17.2.26 RIRBWP—RIRB Write Pointer Register (Intel® High Definition Audio Controller—D27:F0)

Memory Address: HDBAR + 58h                      Attribute:                      R/W, RO  
 Default Value: 0000h                              Size:                              16 bits

Bit	Description
15	<b>RIRB Write Pointer Reset</b> — R/W. Software writes a 1 to this bit to reset the RIRB Write Pointer to 0. The RIRB DMA engine must be stopped prior to resetting the Write Pointer or else DMA transfer may be corrupted.  <b>NOTE:</b> This bit is always read as 0.
14:8	Reserved.
7:0	<b>RIRB Write Pointer (RIRBWP)</b> — RO. This field indicates the last valid RIRB entry written by the DMA controller. Software reads this field to determine how many responses it can read from the RIRB. The value read indicates the RIRB Write Pointer offset in 2 DWord RIRB entry units (since each RIRB entry is 2 DWords long); supports up to 256 RIRB entries (256 x 8 B = 2 KB). This register field may be written when the DMA engine is running.



### 17.2.27 RINTCNT—Response Interrupt Count Register (Intel® High Definition Audio Controller—D27:F0)

Memory Address: HDBAR + 5Ah                      Attribute:                      R/W  
 Default Value: 0000h                              Size:                              16 bits

Bit	Description
15:8	Reserved.
31:0	<p><b>N Response Interrupt Count</b> — R/W.            0000 0001b = 1 response sent to RIRB            .....            1111 1111b = 255 responses sent to RIRB            0000 0000b = 256 responses sent to RIRB</p> <p>The DMA engine should be stopped when changing this field; otherwise, an interrupt may be lost.</p> <p>Note that each response occupies 2 DWords in the RIRB.            This is compared to the total number of responses that have been returned, as opposed to the number of frames in which there were responses. If more than one codec responds in one frame, then the count is increased by the number of responses received in the frame.</p>

### 17.2.28 RIRBCTL—RIRB Control Register (Intel® High Definition Audio Controller—D27:F0)

Memory Address: HDBAR + 5Ch                      Attribute:                      R/W  
 Default Value: 00h                                      Size:                                      8 bits

Bit	Description
7:3	Reserved.
2	<p><b>Response Overrun Interrupt Control</b> — R/W. If this bit is set, the hardware will generate an interrupt when the Response Overrun Interrupt Status bit (HDBAR + 5Dh: bit 2) is set.</p>
1	<p><b>Enable RIRB DMA Engine</b> — R/W. After software writes a 0 to this bit, the hardware may not stop immediately. The hardware will physically update the bit to 0 when the DMA engine is truly stopped. Software must read a 0 from this bit to verify that the DMA engine is truly stopped.</p> <p>0 = DMA stop            1 = DMA run</p>
0	<p><b>Response Interrupt Control</b> — R/W.            0 = Disable Interrupt            1 = Generate an interrupt after N number of responses are sent to the RIRB buffer OR when an empty Response slot is encountered on all SDI[x] inputs (whichever occurs first). The N counter is reset when the interrupt is generated.</p>



### 17.2.29 RIRBSTS—RIRB Status Register (Intel® High Definition Audio Controller—D27:F0)

Memory Address: HDBAR + 5Dh                      Attribute:                      R/WC  
 Default Value:    00h                                      Size:                                8 bits

Bit	Description
7:3	Reserved.
2	<b>Response Overrun Interrupt Status</b> — R/WC. Software sets this bit to 1 when the RIRB DMA engine is not able to write the incoming responses to memory before additional incoming responses overrun the internal FIFO. When the overrun occurs, the hardware will drop the responses which overrun the buffer. An interrupt may be generated if the Response Overrun Interrupt Control bit is set. Note that this status bit is set even if an interrupt is not enabled for this event. Software clears this bit by writing a 1 to it.
1	Reserved.
0	<b>Response Interrupt</b> — R/WC. Hardware sets this bit to 1 when an interrupt has been generated after N number of Responses are sent to the RIRB buffer OR when an empty Response slot is encountered on all SDI[x] inputs (whichever occurs first). Note that this status bit is set even if an interrupt is not enabled for this event. Software clears this bit by writing a 1 to it.

### 17.2.30 RIRBSIZE—RIRB Size Register (Intel® High Definition Audio Controller—D27:F0)

Memory Address: HDBAR + 5Eh                      Attribute:                      RO  
 Default Value:    42h                                      Size:                                8 bits

Bit	Description
7:4	RIRB Size Capability — RO. Hardwired to 0100b indicating that the ICH8 only supports a RIRB size of 256 RIRB entries (2048B).
3:2	Reserved.
1:0	RIRB Size — RO. Hardwired to 10b which sets the CORB size to 256 entries (2048B).

### 17.2.31 IC—Immediate Command Register (Intel® High Definition Audio Controller—D27:F0)

Memory Address: HDBAR + 60h                      Attribute:                      R/W  
 Default Value:    00000000h                                      Size:                                32 bits

Bit	Description
31:0	<b>Immediate Command Write</b> — R/W. The command to be sent to the codec via the Immediate Command mechanism is written to this register. The command stored in this register is sent out over the link during the next available frame after a 1 is written to the ICB bit (HDBAR + 68h: bit 0).



### 17.2.32 IR—Immediate Response Register (Intel® High Definition Audio Controller—D27:F0)

Memory Address: HDBAR + 64h                      Attribute:                      RO  
Default Value: 00000000h                      Size:                      32 bits

Bit	Description
31:0	Immediate Response Read (IRR) — RO. This register contains the response received from a codec resulting from a command sent via the Immediate Command mechanism. If multiple codecs responded in the same time, there is no assurance as to which response will be latched. Therefore, broadcast-type commands must not be issued via the Immediate Command mechanism.

### 17.2.33 IRS—Immediate Command Status Register (Intel® High Definition Audio Controller—D27:F0)

Memory Address: HDBAR + 68h                      Attribute:                      R/W, R/WC  
Default Value: 0000h                      Size:                      16 bits

Bit	Description
15:2	Reserved.
1	<b>Immediate Result Valid (IRV)</b> — R/WC. This bit is set to 1 by hardware when a new response is latched into the Immediate Response register (HDBAR + 64). This is a status flag indicating that software may read the response from the Immediate Response register. Software must clear this bit by writing a 1 to it before issuing a new command so that the software may determine when a new response has arrived.
0	<b>Immediate Command Busy (ICB)</b> — R/W. When this bit is read as 0, it indicates that a new command may be issued using the Immediate Command mechanism. When this bit transitions from 0-to-1 (via software writing a 1), the controller issues the command currently stored in the Immediate Command register to the codec over the link. When the corresponding response is latched into the Immediate Response register, the controller hardware sets the IRV flag and clears the ICB bit back to 0. <b>NOTE:</b> An Immediate Command must not be issued while the CORB/RIRB mechanism is operating; otherwise, the responses conflict. This must be enforced by software.



### 17.2.34 DPLBASE—DMA Position Lower Base Address Register (Intel® High Definition Audio Controller—D27:F0)

Memory Address: HDBAR + 70h  
 Default Value: 00000000h

Attribute: R/W, RO  
 Size: 32 bits

Bit	Description
31:7	<b>DMA Position Lower Base Address</b> — R/W. This field provides the lower 32 bits of the DMA Position Buffer Base Address. This register field must not be written when any DMA engine is running or the DMA transfer may be corrupted. This same address is used by the Flush Control and must be programmed with a valid value before the Flush Control bit (HDBAR+08h:bit 1) is set.
6:1	DMA Position Lower Base Unimplemented bits — RO. Hardwired to 0 to force the 128-byte buffer alignment for cache line write optimizations.
0	<b>DMA Position Buffer Enable</b> — R/W. 0 = Disable. 1 = Enable. Controller will write the DMA positions of each of the DMA engines to the buffer in the main memory periodically (typically, once per frame). Software can use this value to know what data in memory is valid data.

### 17.2.35 DPUBASE—DMA Position Upper Base Address Register (Intel® High Definition Audio Controller—D27:F0)

Memory Address: HDBAR + 74h  
 Default Value: 00000000h

Attribute: R/W  
 Size: 32 bits

Bit	Description
31:0	<b>DMA Position Upper Base Address</b> — R/W. This field provides the upper 32 bits of the DMA Position Buffer Base Address. This register field must not be written when any DMA engine is running or the DMA transfer may be corrupted.



### 17.2.36 SDCTL—Stream Descriptor Control Register (Intel® High Definition Audio Controller—D27:F0)

Memory Address: Input Stream[0]: HDBAR + 80h Attribute: R/W, RO  
 Input Stream[1]: HDBAR + A0h  
 Input Stream[2]: HDBAR + C0h  
 Input Stream[3]: HDBAR + E0h  
 Output Stream[0]: HDBAR + 100h  
 Output Stream[1]: HDBAR + 120h  
 Output Stream[2]: HDBAR + 140h  
 Output Stream[3]: HDBAR + 160h

Default Value: 040000h Size: 24 bits

Bit	Description
23:20	<p><b>Stream Number</b> — R/W. This value reflects the Tag associated with the data being transferred on the link. When data controlled by this descriptor is sent out over the link, it will have its stream number encoded on the SYNC signal. When an input stream is detected on any of the SDI signals that match this value, the data samples are loaded into FIFO associated with this descriptor.</p> <p><b>NOTE:</b> While a single SDI input may contain data from more than one stream number, two different SDI inputs may not be configured with the same stream number.</p> <p>0000 = Reserved            0001 = Stream 1            .....            1110 = Stream 14            1111 = Stream 15</p>
19	<p><b>Bidirectional Direction Control</b> — RO. This bit is only meaningful for bidirectional streams; therefore, this bit is hardwired to 0.</p>
18	<p><b>Traffic Priority</b> — RO. Hardwired to 1 indicating that all streams will use VC1 if it is enabled through the PCI Express* registers.</p>
17:16	<p><b>Stripe Control</b> — RO. This bit is only meaningful for input streams; therefore, this bit is hardwired to 0.</p>
15:5	<p>Reserved</p>
4	<p><b>Descriptor Error Interrupt Enable</b> — R/W.            0 = Disable            1 = Enable. An interrupt is generated when the Descriptor Error Status bit is set.</p>
3	<p><b>FIFO Error Interrupt Enable</b> — R/W. This bit controls whether the occurrence of a FIFO error (overflow for input or underflow for output) will cause an interrupt. If this bit is not set, bit 3 in the Status register will be set, but the interrupt will not occur. Either way, the samples will be dropped.</p>
2	<p><b>Interrupt on Completion Enable</b> — R/W. This bit controls whether or not an interrupt occurs when a buffer completes with the IOC bit set in its descriptor. If this bit is not set, bit 2 in the Status register will be set, but the interrupt will not occur.</p>





Bit	Description
1	<p><b>Stream Run (RUN)</b> — R/W.</p> <p>0 = Disable. When cleared to 0, the DMA engine associated with this input stream will be disabled. The hardware will report a 0 in this bit when the DMA engine is actually stopped. Software must read a 0 from this bit before modifying related control registers or restarting the DMA engine.</p> <p>1 = Enable. When set to 1, the DMA engine associated with this input stream will be enabled to transfer data from the FIFO to the main memory. The SSYNC bit must also be cleared in order for the DMA engine to run. For output streams, the cadence generator is reset whenever the RUN bit is set.</p>
0	<p><b>Stream Reset (SRST)</b> — R/W.</p> <p>0 = Writing a 0 causes the corresponding stream to exit reset. When the stream hardware is ready to begin operation, it will report a 0 in this bit. Software must read a 0 from this bit before accessing any of the stream registers.</p> <p>1 = Writing a 1 causes the corresponding stream to be reset. The Stream Descriptor registers (except the SRST bit itself) and FIFO's for the corresponding stream are reset. After the stream hardware has completed sequencing into the reset state, it will report a 1 in this bit. Software must read a 1 from this bit to verify that the stream is in reset. The RUN bit must be cleared before SRST is asserted.</p>





### 17.2.38 SDLPIB—Stream Descriptor Link Position in Buffer Register (Intel® High Definition Audio Controller—D27:F0)

Memory Address: Input Stream[0]: HDBAR + 84h      Attribute: RO  
 Input Stream[1]: HDBAR + A4h  
 Input Stream[2]: HDBAR + C4h  
 Input Stream[3]: HDBAR + E4h  
 Output Stream[0]: HDBAR + 104h  
 Output Stream[1]: HDBAR + 124h  
 Output Stream[2]: HDBAR + 144h  
 Output Stream[3]: HDBAR + 164h

Default Value: 00000000h      Size: 32 bits

Bit	Description
31:0	Link Position in Buffer — RO. This field indicates the number of bytes that have been received off the link. This register will count from 0 to the value in the Cyclic Buffer Length register and then wrap to 0.

### 17.2.39 SDCBL—Stream Descriptor Cyclic Buffer Length Register (Intel® High Definition Audio Controller—D27:F0)

Memory Address: Input Stream[0]: HDBAR + 88h      Attribute: R/W  
 Input Stream[1]: HDBAR + A8h  
 Input Stream[2]: HDBAR + C8h  
 Input Stream[3]: HDBAR + E8h  
 Output Stream[0]: HDBAR + 108h  
 Output Stream[1]: HDBAR + 128h  
 Output Stream[2]: HDBAR + 148h  
 Output Stream[3]: HDBAR + 168h

Default Value: 00000000h      Size: 32 bits

Bit	Description
31:0	<b>Cyclic Buffer Length</b> — R/W. This field indicates the number of bytes in the complete cyclic buffer. This register represents an integer number of samples. Link Position in Buffer will be reset when it reaches this value. Software may only write to this register after Global Reset, Controller Reset, or Stream Reset has occurred. This value should be only modified when the RUN bit is 0. Once the RUN bit has been set to enable the engine, software must not write to this register until after the next reset is asserted, or transfer may be corrupted.



### 17.2.40 SDLVI—Stream Descriptor Last Valid Index Register (Intel® High Definition Audio Controller—D27:F0)

Memory Address: Input Stream[0]: HDBAR + 8Ch      Attribute: R/W  
 Input Stream[1]: HDBAR + ACh  
 Input Stream[2]: HDBAR + CCh  
 Input Stream[3]: HDBAR + ECh  
 Output Stream[0]: HDBAR + 10Ch  
 Output Stream[1]: HDBAR + 12Ch  
 Output Stream[2]: HDBAR + 14Ch  
 Output Stream[3]: HDBAR + 16Ch

Default Value: 0000h      Size: 16 bits

Bit	Description
15:8	Reserved.
7:0	<p><b>Last Valid Index</b> — R/W. The value written to this register indicates the index for the last valid Buffer Descriptor in BDL. After the controller has processed this descriptor, it will wrap back to the first descriptor in the list and continue processing.</p> <p>This field must be at least 1 (i.e., there must be at least 2 valid entries in the buffer descriptor list before DMA operations can begin).</p> <p>This value should only modified when the RUN bit is 0.</p>

### 17.2.41 SDFIFOW—Stream Descriptor FIFO Watermark Register (Intel® High Definition Audio Controller—D27:F0)

Memory Address: Input Stream[0]: HDBAR + 8Eh      Attribute: R/W  
 Input Stream[1]: HDBAR + AEh  
 Input Stream[2]: HDBAR + CEh  
 Input Stream[3]: HDBAR + EEh  
 Output Stream[0]: HDBAR + 10Eh  
 Output Stream[1]: HDBAR + 12Eh  
 Output Stream[2]: HDBAR + 14Eh  
 Output Stream[3]: HDBAR + 16Eh

Default Value: 0004h      Size: 16 bits

Bit	Description
15:3	Reserved.
2:0	<p><b>FIFO Watermark (FIFOW)</b> — R/W. This field indicates the minimum number of bytes accumulated/free in the FIFO before the controller will start a fetch/eviction of data.</p> <p>010 = 8B          011 = 16B          100 = 32B (Default)          Others = Unsupported</p> <p><b>NOTES:</b></p> <ol style="list-style-type: none"> <li>When the bit field is programmed to an unsupported size, the hardware sets itself to the default value.</li> <li>Software must read the bit field to test if the value is supported after setting the bit field.</li> </ol>



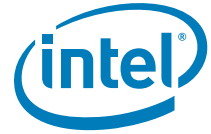
### 17.2.42 SDFIFOS—Stream Descriptor FIFO Size Register (Intel® High Definition Audio Controller—D27:F0)

Memory Address: Input Stream[0]: HDBAR + 90h    Attribute:    Input: RO  
                   Input Stream[1]: HDBAR + B0h    Output:        R/W  
                   Input Stream[2]: HDBAR + D0h  
                   Input Stream[3]: HDBAR + F0h  
                   Output Stream[0]: HDBAR + 110h  
                   Output Stream[1]: HDBAR + 130h  
                   Output Stream[2]: HDBAR + 150h  
                   Output Stream[3]: HDBAR + 170h

Default Value:    Input Stream: 0077h                    Size:                16 bits  
                   Output Stream: 00BFh

Bit	Description																				
15:8	Reserved.																				
7:0	<p><b>FIFO Size</b> — RO (Input stream), R/W (Output stream). This field indicates the maximum number of bytes that could be fetched by the controller at one time. This is the maximum number of bytes that may have been DMA'd into memory but not yet transmitted on the link, and is also the maximum possible value that the PICB count will increase by at one time.</p> <p>The value in this field is different for input and output streams. It is also dependent on the Bits per Samples setting for the corresponding stream. Following are the values read/written from/to this register for input and output streams, and for non-padded and padded bit formats:</p> <p><b>Output Stream R/W value</b></p> <table border="0"> <thead> <tr> <th>Value</th> <th>Output Streams</th> </tr> </thead> <tbody> <tr> <td>0Fh = 16B</td> <td>8, 16, 20, 24, or 32 bit Output Streams</td> </tr> <tr> <td>1Fh = 32B</td> <td>8, 16, 20, 24, or 32 bit Output Streams</td> </tr> <tr> <td>3Fh = 64B</td> <td>8, 16, 20, 24, or 32 bit Output Streams</td> </tr> <tr> <td>7Fh = 128B</td> <td>8, 16, 20, 24, or 32 bit Output Streams</td> </tr> <tr> <td>BFh = 192B</td> <td>8, 16, or 32 bit Output Streams</td> </tr> <tr> <td>FFh = 256B</td> <td>20, 24 bit Output Streams</td> </tr> </tbody> </table> <p><b>NOTES:</b></p> <ol style="list-style-type: none"> <li>All other values not listed are not supported.</li> <li>When the output stream is programmed to an unsupported size, the hardware sets itself to the default value (BFh).</li> <li>Software must read the bit field to test if the value is supported after setting the bit field.</li> </ol> <p><b>Input Stream RO value</b></p> <table border="0"> <thead> <tr> <th>Value</th> <th>Input Streams</th> </tr> </thead> <tbody> <tr> <td>77h = 120B</td> <td>8, 16, 32 bit Input Streams</td> </tr> <tr> <td>9Fh = 160B</td> <td>20, 24 bit Input Streams</td> </tr> </tbody> </table> <p><b>NOTE:</b> The default value is different for input and output streams, and reflects the default state of the BITS fields (in Stream Descriptor Format registers) for the corresponding stream.</p>	Value	Output Streams	0Fh = 16B	8, 16, 20, 24, or 32 bit Output Streams	1Fh = 32B	8, 16, 20, 24, or 32 bit Output Streams	3Fh = 64B	8, 16, 20, 24, or 32 bit Output Streams	7Fh = 128B	8, 16, 20, 24, or 32 bit Output Streams	BFh = 192B	8, 16, or 32 bit Output Streams	FFh = 256B	20, 24 bit Output Streams	Value	Input Streams	77h = 120B	8, 16, 32 bit Input Streams	9Fh = 160B	20, 24 bit Input Streams
Value	Output Streams																				
0Fh = 16B	8, 16, 20, 24, or 32 bit Output Streams																				
1Fh = 32B	8, 16, 20, 24, or 32 bit Output Streams																				
3Fh = 64B	8, 16, 20, 24, or 32 bit Output Streams																				
7Fh = 128B	8, 16, 20, 24, or 32 bit Output Streams																				
BFh = 192B	8, 16, or 32 bit Output Streams																				
FFh = 256B	20, 24 bit Output Streams																				
Value	Input Streams																				
77h = 120B	8, 16, 32 bit Input Streams																				
9Fh = 160B	20, 24 bit Input Streams																				





### 17.2.44 SDBDPL—Stream Descriptor Buffer Descriptor List Pointer Lower Base Address Register (Intel® High Definition Audio Controller—D27:F0)

Memory Address: Input Stream[0]: HDBAR + 98h Attribute: R/W,RO  
 Input Stream[1]: HDBAR + B8h  
 Input Stream[2]: HDBAR + D8h  
 Input Stream[3]: HDBAR + F8h  
 Output Stream[0]: HDBAR + 118h  
 Output Stream[1]: HDBAR + 138h  
 Output Stream[2]: HDBAR + 158h  
 Output Stream[3]: HDBAR + 178h

Default Value: 00000000h Size: 32 bits

Bit	Description
31:7	<b>Buffer Descriptor List Pointer Lower Base Address</b> — R/W. This field provides the lower address of the Buffer Descriptor List. This value should only be modified when the RUN bit is 0, or DMA transfer may be corrupted.
6:0	Hardwired to 0 forcing alignment on 128-B boundaries.

### 17.2.45 SBDPU—Stream Descriptor Buffer Descriptor List Pointer Upper Base Address Register (Intel® High Definition Audio Controller—D27:F0)

Memory Address: Input Stream[0]: HDBAR + 9Ch Attribute: R/W  
 Input Stream[1]: HDBAR + BCh  
 Input Stream[2]: HDBAR + DCh  
 Input Stream[3]: HDBAR + FCh  
 Output Stream[0]: HDBAR + 11Ch  
 Output Stream[1]: HDBAR + 13Ch  
 Output Stream[2]: HDBAR + 15Ch  
 Output Stream[3]: HDBAR + 17Ch

Default Value: 00000000h Size: 32 bits

Bit	Description
31:0	<b>Buffer Descriptor List Pointer Upper Base Address</b> — R/W. This field provides the upper 32-bit address of the Buffer Descriptor List. This value should only be modified when the RUN bit is 0, or DMA transfer may be corrupted.

§ §







# 18 PCI Express\* Configuration Registers

## 18.1 PCI Express\* Configuration Registers (PCI Express—D28:F0/F1/F2/F3/F4/F5)

**Note:** Register address locations that are not shown in Table 141 and should be treated as Reserved.

**Table 141. PCI Express\* Configuration Registers Address Map (PCI Express—D28:F0/F1/F2/F3/F4/F5) (Sheet 1 of 3)**

Offset	Mnemonic	Register Name	Function 0–5 Default	Type
00h–01h	VID	Vendor Identification	8086h	RO
02h–03h	DID	Device Identification	See register description	RO
04h–05h	PCICMD	PCI Command	0000h	R/W, RO
06h–07h	PCISTS	PCI Status	0010h	R/WC, RO
08h	RID	Revision Identification	See register description	RO
09h	PI	Programming Interface	00h	RO
0Ah	SCC	Sub Class Code	04h	RO
0Bh	BCC	Base Class Code	06h	RO
0Ch	CLS	Cache Line Size	00h	R/W
0Dh	PLT	Primary Latency Timer	00h	RO
0Eh	HEADTYP	Header Type	81h	RO
18h–1Ah	BNUM	Bus Number	000000h	R/W
1Bh	SLT	Secondary Latency Timer	0h	RO
1Ch–1Dh	IOBL	I/O Base and Limit	0000h	R/W, RO
1Eh–1Fh	SSTS	Secondary Status	0000h	R/WC
20h–23h	MBL	Memory Base and Limit	00000000h	R/W
24h–27h	PMBL	Prefetchable Memory Base and Limit	00010001h	R/W, RO
28h–2Bh	PMBU32	Prefetchable Memory Base Upper 32 Bits	00000000h	R/W
2Ch–2Fh	PMLU32	Prefetchable Memory Limit Upper 32 Bits	00000000h	R/W
34h	CAPP	Capabilities List Pointer	40h	RO
3Ch–3Dh	INTR	Interrupt Information	See bit description	R/W, RO
3Eh–3Fh	BCTRL	Bridge Control Register	0000h	R/W
40h–41h	CLIST	Capabilities List	8010	RO



**Table 141. PCI Express\* Configuration Registers Address Map (PCI Express—D28:F0/F1/F2/F3/F4/F5) (Sheet 2 of 3)**

Offset	Mnemonic	Register Name	Function 0–5 Default	Type
42h–43h	XCAP	PCI Express* Capabilities	0041	R/WO, RO
44h–47h	DCAP	Device Capabilities	0000FE0h	RO
48h–49h	DCTL	Device Control	0000h	R/W, RO
4Ah–4Bh	DSTS	Device Status	0010h	R/WC, RO
4Ch–4Fh	LCAP	Link Capabilities	See bit description	R/W, RO, R/WO
50h–51h	LCTL	Link Control	0000h	R/W, WO, RO
52h–53h	LSTS	Link Status	See bit description	RO
54h–57h	SLCAP	Slot Capabilities Register	0000060h	R/WO, RO
58h–59h	SLCTL	Slot Control	0000h	R/W, RO
5Ah–5Bh	SLSTS	Slot Status	0000h	R/WC, RO
5Ch–5Dh	RCTL	Root Control	0000h	R/W
60h–63h	RSTS	Root Status	00000000h	R/WC, RO
80h–81h	MID	Message Signaled Interrupt Identifiers	9005h	RO
82h–83h	MC	Message Signaled Interrupt Message Control	0000h	R/W, RO
84h–87h	MA	Message Signaled Interrupt Message Address	00000000h	R/W
88h–89h	MD	Message Signaled Interrupt Message Data	0000h	R/W
90h–91h	SVCAP	Subsystem Vendor Capability	A00Dh	RO
94h–97h	SVID	Subsystem Vendor Identification	00000000h	R/WO
A0h–A1h	PMCAP	Power Management Capability	0001h	RO
A2h–A3h	PMC	PCI Power Management Capability	C802h	RO
A4–A7h	PMCS	PCI Power Management Control and Status	00000000h	R/W, RO
D8–DBh	MPC	Miscellaneous Port Configuration	00110000h	R/W
DC–DFh	SMSCS	SMI/SCI Status Register	00000000h	R/WC
E1h	RPDCGEN	Root Port Dynamic Clock Gating Enable (Mobile Only)	00h	R/W
E2–E3h	IPWS	Intel® PRO/Wireless 3945ABG Status	0000h	RO
100–103h	VCH	Virtual Channel Capability Header	18010002h	RO
104h–107h	—	Reserved	—	—
108h–10Bh	VCAP2	Virtual Channel Capability 2	00000001h	RO
10Ch–10Dh	PVC	Port Virtual Channel Control	0000h	R/W
10Eh–10Fh	PVS	Port Virtual Channel Status	0000h	RO



**Table 141. PCI Express\* Configuration Registers Address Map (PCI Express—D28:F0/F1/F2/F3/F4/F5) (Sheet 3 of 3)**

Offset	Mnemonic	Register Name	Function 0–5 Default	Type
110h–113h	VOCAP	Virtual Channel 0 Resource Capability	00000001h	RO
114–117h	VOCTL	Virtual Channel 0 Resource Control	800000FFh	R/W, RO
11A–11Bh	VOSTS	Virtual Channel 0 Resource Status	0000h	RO
11Ch–143h	—	Reserved	—	—
144h–147h	UES	Uncorrectable Error Status	See bit description	R/WC, RO
148h–14Bh	UEM	Uncorrectable Error Mask	00000000h	R/WO, RO
14Ch–14Fh	UEV	Uncorrectable Error Severity	00060011h	RO
150h–153h	CES	Correctable Error Status	00000000h	R/WC
154h–157h	CEM	Correctable Error Mask	00000000h	R/WO
158h–15Bh	AECC	Advanced Error Capabilities and Control	00000000h	RO
170h–173h	RES	Root Error Status	00000000h	R/WC, RO
180h–183h	RCTCL	Root Complex Topology Capability List	00010005h	RO
184h–187h	ESD	Element Self Description	See bit description	RO
190h–193h	ULD	Upstream Link Description	00000001h	RO
198h–19Fh	ULBA	Upstream Link Base Address	See bit description	RO
318h	PEETM	PCI Express Extended Test Mode Register	00h	RO





### 18.1.3 PCICMD—PCI Command Register (PCI Express—D28:F0/F1/F2/F3/F4/F5)

Address Offset: 04h–05h  
Default Value: 0000h

Attribute: R/W, RO  
Size: 16 bits

Bit	Description
15:11	Reserved
10	<p><b>Interrupt Disable</b> — R/W. This bit disables pin-based INTx# interrupts on enabled Hot-Plug and power management events. This bit has no effect on MSI operation.</p> <p>0 = Internal INTx# messages are generated if there is an interrupt for Hot-Plug or power management and MSI is not enabled. 1 = Internal INTx# messages will not be generated.</p> <p>This bit does not affect interrupt forwarding from devices connected to the root port. Assert_INTx and Deassert_INTx messages will still be forwarded to the internal interrupt controllers if this bit is set.</p>
9	<b>Fast Back to Back Enable (FBE)</b> — Reserved per the <i>PCI Express* Base Specification</i> .
8	<p><b>SERR# Enable (SEE)</b> — R/W.</p> <p>0 = Disable. 1 = Enables the root port to generate an SERR# message when PSTS.SSE is set.</p>
7	<b>Wait Cycle Control (WCC)</b> — Reserved per the <i>PCI Express Base Specification</i> .
6	<p><b>Parity Error Response (PER)</b> — R/W.</p> <p>0 = Disable. 1 = Device is capable of reporting parity errors as a master on the backbone.</p>
5	<b>VGA Palette Snoop (VPS)</b> — Reserved per the <i>PCI Express* Base Specification</i> .
4	<b>Postable Memory Write Enable (PMWE)</b> — Reserved per the <i>PCI Express* Base Specification</i> .
3	<b>Special Cycle Enable (SCE)</b> — Reserved per the <i>PCI Express* Base Specification</i> .
2	<p><b>Bus Master Enable (BME)</b> — R/W.</p> <p>0 = Disable. All cycles from the device are master aborted 1 = Enable. Allows the root port to forward cycles onto the backbone from a PCI Express* device.</p>
1	<p><b>Memory Space Enable (MSE)</b> — R/W.</p> <p>0 = Disable. Memory cycles within the range specified by the memory base and limit registers are master aborted on the backbone. 1 = Enable. Allows memory cycles within the range specified by the memory base and limit registers can be forwarded to the PCI Express device.</p>
0	<p><b>I/O Space Enable (IOSE)</b> — R/W. This bit controls access to the I/O space registers.</p> <p>0 = Disable. I/O cycles within the range specified by the I/O base and limit registers are master aborted on the backbone. 1 = Enable. Allows I/O cycles within the range specified by the I/O base and limit registers can be forwarded to the PCI Express device.</p>



### 18.1.4 PCISTS—PCI Status Register (PCI Express—D28:F0/F1/F2/F3/F4/F5)

Address Offset: 06h–07h                      Attribute: R/WC, RO  
 Default Value: 0010h                      Size: 16 bits

Bit	Description
15	<b>Detected Parity Error (DPE)</b> — R/WC. 0 = No parity error detected. 1 = Set when the root port receives a command or data from the backbone with a parity error. This is set even if PCIMD.PER (D28:F0/F1/F2/F3:04, bit 6) is not set.
14	<b>Signaled System Error (SSE)</b> — R/WC. 0 = No system error signaled. 1 = Set when the root port signals a system error to the internal SERR# logic.
13	<b>Received Master Abort (RMA)</b> — R/WC. 0 = Root port has not received a completion with unsupported request status from the backbone. 1 = Set when the root port receives a completion with unsupported request status from the backbone.
12	<b>Received Target Abort (RTA)</b> — R/WC. 0 = Root port has not received a completion with completer abort from the backbone. 1 = Set when the root port receives a completion with completer abort from the backbone.
11	<b>Signaled Target Abort (STA)</b> — R/WC. 0 = No target abort received. 1 = Set whenever the root port forwards a target abort received from the downstream device onto the backbone.
10:9	DEVSEL# Timing Status (DEV_STS) — Reserved per the <i>PCI Express* Base Specification</i> .
8	<b>Master Data Parity Error Detected (DPED)</b> — R/WC. 0 = No data parity error received. 1 = Set when the root port receives a completion with a data parity error on the backbone and PCIMD.PER (D28:F0/F1/F2/F3:04, bit 6) is set.
7	Fast Back to Back Capable (FB2BC) — Reserved per the <i>PCI Express* Base Specification</i> .
6	Reserved
5	66 MHz Capable — Reserved per the <i>PCI Express* Base Specification</i> .
4	Capabilities List — RO. Hardwired to 1. Indicates the presence of a capabilities list.
3	<b>Interrupt Status</b> — RO. Indicates status of Hot-Plug and power management interrupts on the root port that result in INTx# message generation. 0 = Interrupt is deasserted. 1 = Interrupt is asserted. This bit is not set if MSI is enabled. If MSI is not enabled, this bit is set regardless of the state of PCICMD.Interrupt Disable bit (D28:F0/F1/F2/F3/F4/F5:04h:bit 10).
2:0	Reserved











### 18.1.15 SSTS—Secondary Status Register (PCI Express—D28:F0/F1/F2/F3/F4/F5)

Address Offset: 1Eh–1Fh                      Attribute: R/WC  
 Default Value: 0000h                      Size: 16 bits

Bit	Description
15	<b>Detected Parity Error (DPE)</b> — R/WC. 0 = No error. 1 = The port received a poisoned TLP.
14	<b>Received System Error (RSE)</b> — R/WC. 0 = No error. 1 = The port received an ERR_FATAL or ERR_NONFATAL message from the device.
13	<b>Received Master Abort (RMA)</b> — R/WC. 0 = Unsupported Request not received. 1 = The port received a completion with “Unsupported Request” status from the device.
12	<b>Received Target Abort (RTA)</b> — R/WC. 0 = Completion Abort not received. 1 = The port received a completion with “Completion Abort” status from the device.
11	<b>Signaled Target Abort (STA)</b> — R/WC. 0 = Completion Abort not sent. 1 = The port generated a completion with “Completion Abort” status to the device.
10:9	Secondary DEVSEL# Timing Status (SDTS): Reserved per <i>PCI Express* Base Specification</i> .
8	<b>Data Parity Error Detected (DPD)</b> — R/WC. 0 = Conditions below did not occur 1 = Set when the BCTRL.PERE (D28:F0/F1/F2/F3/F4/F5:3E: bit 0) is set, and either of the following two conditions occurs: <ul style="list-style-type: none"> <li>• Port receives completion marked poisoned.</li> <li>• Port poisons a write request to the secondary side.</li> </ul>
7	Secondary Fast Back to Back Capable (SFBC): Reserved per <i>PCI Express* Base Specification</i> .
6	Reserved
5	Secondary 66 MHz Capable (SC66): Reserved per <i>PCI Express* Base Specification</i> .
4:0	Reserved



### 18.1.16 MBL—Memory Base and Limit Register (PCI Express—D28:F0/F1/F2/F3/F4/F5)

Address Offset: 20h–23h                      Attribute: R/W  
 Default Value: 00000000h                  Size: 32 bits

Accesses that are within the ranges specified in this register will be sent to the attached device if CMD.MSE (D28:F0/F1/F2/F3/F4/F5:04:bit 1) is set. Accesses from the attached device that are outside the ranges specified will be forwarded to the backbone if CMD.BME (D28:F0/F1/F2/F3/F4/F5:04:bit 2) is set. The comparison performed is  $MB \geq AD[31:20] \leq ML$ .

Bit	Description
31:20	<b>Memory Limit (ML)</b> — R/W. These bits are compared with bits 31:20 of the incoming address to determine the upper 1-MB aligned value of the range.
19:16	Reserved
15:4	<b>Memory Base (MB)</b> — R/W. These bits are compared with bits 31:20 of the incoming address to determine the lower 1-MB aligned value of the range.
3:0	Reserved

### 18.1.17 PMBL—Prefetchable Memory Base and Limit Register (PCI Express—D28:F0/F1/F2/F3/F4/F5)

Address Offset: 24h–27h                      Attribute: R/W, RO  
 Default Value: 00010001h                  Size: 32 bits

Accesses that are within the ranges specified in this register will be sent to the device if CMD.MSE (D28:F0/F1/F2/F3/F4/F5:04, bit 1) is set. Accesses from the device that are outside the ranges specified will be forwarded to the backbone if CMD.BME (D28:F0/F1/F2/F3/F4/F5:04, bit 2) is set. The comparison performed is  $PMBU32:PMB \geq AD[63:32]:AD[31:20] \leq PMLU32:PML$ .

Bit	Description
31:20	<b>Prefetchable Memory Limit (PML)</b> — R/W. These bits are compared with bits 31:20 of the incoming address to determine the upper 1-MB aligned value of the range.
19:16	64-bit Indicator (I64L) — RO. Indicates support for 64-bit addressing
15:4	<b>Prefetchable Memory Base (PMB)</b> — R/W. These bits are compared with bits 31:20 of the incoming address to determine the lower 1-MB aligned value of the range.
3:0	64-bit Indicator (I64B) — RO. Indicates support for 64-bit addressing



### 18.1.18 PMBU32—Prefetchable Memory Base Upper 32 Bits Register (PCI Express—D28:F0/F1/F2/F3/F4/F5)

Address Offset: 28h–2Bh                      Attribute: R/W  
Default Value: 00000000h                      Size: 32 bits

Bit	Description
31:0	<b>Prefetchable Memory Base Upper Portion (PMBU)</b> — R/W. This field provides the upper 32-bits of the prefetchable address base.

### 18.1.19 PMLU32—Prefetchable Memory Limit Upper 32 Bits Register (PCI Express—D28:F0/F1/F2/F3/F4/F5)

Address Offset: 2Ch–2Fh                      Attribute: R/W  
Default Value: 00000000h                      Size: 32 bits

Bit	Description
31:0	<b>Prefetchable Memory Limit Upper Portion (PMLU)</b> — R/W. This field provides the upper 32-bits of the prefetchable address limit.

### 18.1.20 CAPP—Capabilities List Pointer Register (PCI Express—D28:F0/F1/F2/F3/F4/F5)

Address Offset: 34h                              Attribute: R0  
Default Value: 40h                              Size: 8 bits

Bit	Description
7:0	<b>Capabilities Pointer (PTR)</b> — R0. This field indicates that the pointer for the first entry in the capabilities list is at 40h in configuration space.









### 18.1.26 DCTL—Device Control Register (PCI Express—D28:F0/F1/F2/F3/F4/F5)

Address Offset: 48h–49h                      Attribute: R/W, RO  
 Default Value: 0000h                      Size: 16 bits

Bit	Description
15	Reserved
14:12	Max Read Request Size (MRRS) — RO. Hardwired to 0.
11	<b>Enable No Snoop (ENS)</b> — RO. Not supported. The root port will never issue non-snoop requests.
10	<b>Aux Power PM Enable (APME)</b> — R/W. The OS will set this bit to 1 if the device connected has detected aux power. It has no effect on the root port otherwise.
9	<b>Phantom Functions Enable (PFE)</b> — RO. Not supported.
8	<b>Extended Tag Field Enable (ETFE)</b> — RO. Not supported.
7:5	<b>Max Payload Size (MPS)</b> — R/W. The root port only supports 128-B payloads, regardless of the programming of this field.
4	<b>Enable Relaxed Ordering (ERO)</b> — RO. Not supported.
3	<b>Unsupported Request Reporting Enable (URE)</b> — R/W. 0 = Disable. The root port will ignore unsupported request errors. 1 = Enable. Allows signaling ERR_NONFATAL, ERR_FATAL, or ERR_COR to the Root Control register when detecting an unmasked Unsupported Request (UR). An ERR_COR is signaled when a unmasked Advisory Non-Fatal UR is received. An ERR_FATAL, ERR_or NONFATAL, is sent to the Root Control Register when an uncorrectable non-Advisory UR is received with the severity set by the Uncorrectable Error Severity register.
2	<b>Fatal Error Reporting Enable (FEE)</b> — R/W. 0 = Disable. The root port will ignore fatal errors. 1 = Enables signaling of ERR_FATAL to the Root Control register due to internally detected errors or error messages received across the link. Other bits also control the full scope of related error reporting.
1	<b>Non-Fatal Error Reporting Enable (NFE)</b> — R/W. 0 = Disable. The root port will ignore non-fatal errors. 1 = Enables signaling of ERR_NONFATAL to the Root Control register due to internally detected errors or error messages received across the link. Other bits also control the full scope of related error reporting.
0	<b>Correctable Error Reporting Enable (CEE)</b> — R/W. 0 = Disable. The root port will ignore correctable errors. 1 = Enables signaling of ERR_CORR to the Root Control register due to internally detected errors or error messages received across the link. Other bits also control the full scope of related error reporting.







Bit	Description																										
19:18	Reserved																										
17:15	<b>L1 Exit Latency (EL1)</b> — RO. Set to 010b to indicate an exit latency of 2 $\mu$ s to 4 $\mu$ s.																										
14:12	<p><b>LOs Exit Latency (ELO)</b> — RO. This field indicates as exit latency based upon common-clock configuration.</p> <table border="0"> <thead> <tr> <th>LCLT.CCC</th> <th>Value of ELO (these bits)</th> </tr> </thead> <tbody> <tr> <td>0</td> <td>MPC.UCEL (D28:F0/F1/F2/F3:D8h:bits20:18)</td> </tr> <tr> <td>1</td> <td>MPC.CCEL (D28:F0/F1/F2/F3:D8h:bits17:15)</td> </tr> </tbody> </table> <p><b>NOTE:</b> LCLT.CCC is at D28:F0/F1/F2/F3/F4/F5:50h:bit 6</p>	LCLT.CCC	Value of ELO (these bits)	0	MPC.UCEL (D28:F0/F1/F2/F3:D8h:bits20:18)	1	MPC.CCEL (D28:F0/F1/F2/F3:D8h:bits17:15)																				
LCLT.CCC	Value of ELO (these bits)																										
0	MPC.UCEL (D28:F0/F1/F2/F3:D8h:bits20:18)																										
1	MPC.CCEL (D28:F0/F1/F2/F3:D8h:bits17:15)																										
11:10	<p><b>Active State Link PM Support (APMS)</b> — R/WO. This field indicates what level of active state link power management is supported on the root port.</p> <table border="0"> <thead> <tr> <th>Bits</th> <th>Definition</th> </tr> </thead> <tbody> <tr> <td>00b</td> <td>Neither LOs nor L1 are supported</td> </tr> <tr> <td>01b</td> <td>LOs Entry Supported</td> </tr> <tr> <td>10b</td> <td>L1 Entry Supported</td> </tr> <tr> <td>11b</td> <td>Both LOs and L1 Entry Supported</td> </tr> </tbody> </table>	Bits	Definition	00b	Neither LOs nor L1 are supported	01b	LOs Entry Supported	10b	L1 Entry Supported	11b	Both LOs and L1 Entry Supported																
Bits	Definition																										
00b	Neither LOs nor L1 are supported																										
01b	LOs Entry Supported																										
10b	L1 Entry Supported																										
11b	Both LOs and L1 Entry Supported																										
9:4	<p><b>Maximum Link Width (MLW)</b> — RO. For the root ports, several values can be taken, based upon the value of the chipset config register field RPC.PC1 (Chipset Config Registers: Offset 0224h:bits1:0) for Ports 1-4 and RPC.PC2 (Chipset Config Registers: Offset 0224h:bits1:0) for Ports 5 and 6</p> <table border="0"> <thead> <tr> <th rowspan="2">Port #</th> <th colspan="2">Value of MLW Field</th> </tr> <tr> <th>RPC.PC1=00b</th> <th>RPC.PC1=11b</th> </tr> </thead> <tbody> <tr> <td>1</td> <td>01h</td> <td>04h</td> </tr> <tr> <td>2</td> <td>01h</td> <td>01h</td> </tr> <tr> <td>3</td> <td>01h</td> <td>01h</td> </tr> <tr> <td>4</td> <td>01h</td> <td>01h</td> </tr> <tr> <td>Port #</td> <td>RPC.PC2=00b</td> <td>RPC.PC2=11b</td> </tr> <tr> <td>5</td> <td>01h</td> <td>N/A</td> </tr> <tr> <td>6</td> <td>01h</td> <td>N/A</td> </tr> </tbody> </table>	Port #	Value of MLW Field		RPC.PC1=00b	RPC.PC1=11b	1	01h	04h	2	01h	01h	3	01h	01h	4	01h	01h	Port #	RPC.PC2=00b	RPC.PC2=11b	5	01h	N/A	6	01h	N/A
Port #	Value of MLW Field																										
	RPC.PC1=00b	RPC.PC1=11b																									
1	01h	04h																									
2	01h	01h																									
3	01h	01h																									
4	01h	01h																									
Port #	RPC.PC2=00b	RPC.PC2=11b																									
5	01h	N/A																									
6	01h	N/A																									
3:0	<b>Maximum Link Speed (MLS)</b> — RO. Set to 1h to indicate the link speed is 2.5 Gb/s.																										





### 18.1.30 LSTS—Link Status Register (PCI Express—D28:F0/F1/F2/F3/F4/F5)

Address Offset: 52h–53h                      Attribute: RO  
 Default Value: See bit description        Size: 16 bits

Bit	Description														
15:14	Reserved														
13	<b>Data Link Layer Active (DLLA)</b> — RO. Default value is 0b. 0 = Data Link Control and Management State Machine is not in the DL_Active state 1 = Data Link Control and Management State Machine is in the DL_Active state														
12	Slot Clock Configuration (SCC) — RO. Set to 1b to indicate that the Intel® ICH8 uses the same reference clock as on the platform and does not generate its own clock.														
11	<b>Link Training (LT)</b> — RO. Default value is 0b. 0 = Link training completed. 1 = Link training is occurring.														
10	Link Training Error (LTE) — RO. Not supported. Set value is 0b.														
9:4	<b>Negotiated Link Width (NLW)</b> — RO. This field indicates the negotiated width of the given PCI Express* link. The contents of this NLW field is undefined if the link has not successfully trained.  <table border="1"> <thead> <tr> <th>Port #</th> <th>Possible Values</th> </tr> </thead> <tbody> <tr> <td>1</td> <td>000001b, 000010b, 000100b</td> </tr> <tr> <td>2</td> <td>000001b</td> </tr> <tr> <td>3</td> <td>000001b</td> </tr> <tr> <td>4</td> <td>000001b</td> </tr> <tr> <td>5</td> <td>000001b, 000010b</td> </tr> <tr> <td>6</td> <td>000001b</td> </tr> </tbody> </table> <b>NOTE:</b> 000001b = x1 link width, 000010b =x2 linkwidth (not supported), 000100b = x4 linkwidth	Port #	Possible Values	1	000001b, 000010b, 000100b	2	000001b	3	000001b	4	000001b	5	000001b, 000010b	6	000001b
Port #	Possible Values														
1	000001b, 000010b, 000100b														
2	000001b														
3	000001b														
4	000001b														
5	000001b, 000010b														
6	000001b														
3:0	<b>Link Speed (LS)</b> — RO. This field indicates the negotiated Link speed of the given PCI Express* link. 01h = Link is 2.5 Gb/s.														







Bit	Description
2	<b>MRL Sensor Changed Enable (MSE)</b> — R/W. MSE not supported.
1	<b>Power Fault Detected Enable (PFE)</b> — R/W. PFE not supported.
0	<b>Attention Button Pressed Enable (ABE)</b> — R/W. When set, enables the generation of a Hot-Plug interrupt when the attention button is pressed. 0 = Disable. Hot plug interrupts based on the attention button being pressed is disabled. 1 = Enables the generation of a Hot-Plug interrupt when the attention button is pressed.

### 18.1.33 SLSTS—Slot Status Register (PCI Express—D28:F0/F1/F2/F3/F4/F5)

Address Offset: 5Ah–5Bh  
Default Value: 0000h

Attribute: R/WC, RO  
Size: 16 bits

Bit	Description
15:9	Reserved
8	<b>Link Active State Changed (LASC)</b> — R/WC. This bit is set when the value reported in Data Link Layer Link Active field of the Link Status register (D28:F0/F1/F2/F3/F4/F5:52h:bit 13) is changed. In response to a Data Link Layer State Changed event, software must read Data Link Layer Link Active field of the Link Status register to determine if the link is active before initiating configuration cycles to the hot plugged device. 0 = No change. 1 = Change
7	Reserved
6	<b>Presence Detect State (PDS)</b> — RO. If XCAP.SI (D28:F0/F1/F2/F3/F4/F5:42h:bit 8) is set (indicating that this root port spawns a slot), then this bit: 0 = Slot is empty. 1 = Slot has a device connected. Otherwise, if XCAP.SI is cleared, this bit is always set to 1.
5	MRL Sensor State (MS) — Reserved as the MRL sensor is not implemented.
4	<b>Command Completed (CC)</b> — R/WC. 0 = Issued command not completed. 1 = The Hot-Plug controller completed an issued command. This is set when the last message of a command is sent and indicates that software can write a new command to the slot controller.
3	<b>Presence Detect Changed (PDC)</b> — R/WC. 0 = No change in the PDS bit. 1 = The PDS bit changed states.
2	MRL Sensor Changed (MSC) — Reserved as the MRL sensor is not implemented.
1	Power Fault Detected (PFD) — Reserved as a power controller is not implemented.
0	<b>Attention Button Pressed (ABP)</b> — R/WC. 0 = The attention button has Not been pressed. 1 = The attention button is pressed.



### 18.1.34 RCTL—Root Control Register (PCI Express—D28:F0/F1/F2/F3/F4/F5)

Address Offset: 5Ch–5Dh                      Attribute: R/W  
Default Value: 0000h                      Size: 16 bits

Bit	Description
15:4	Reserved
3	<b>PME Interrupt Enable (PIE)</b> — R/W. 0 = Disable. Interrupt generation disabled. 1 = Interrupt generation enabled when PCISTS.Inerrupt Status (D28:F0/F1/F2/F3/F4/F5:60h, bit 16) is in a set state (either due to a 0-to-1 transition, or due to this bit being set with RSTS.IS already set).
2	<b>System Error on Fatal Error Enable (SFE)</b> — R/W. 0 = An SERR# will Not be generated. 1 = An SERR# will be generated, assuming CMD.SEE (D28:F0/F1/F2/F3/F4/F5:04, bit 8) is set, if a fatal error is reported by any of the devices in the hierarchy of this root port, including fatal errors in this root port.
1	<b>System Error on Non-Fatal Error Enable (SNE)</b> — R/W. 0 = An SERR# will Not be generated. 1 = An SERR# will be generated, assuming CMD.SEE (D28:F0/F1/F2/F3/F4/F5:04, bit 8) is set, if a non-fatal error is reported by any of the devices in the hierarchy of this root port, including non-fatal errors in this root port.
0	<b>System Error on Correctable Error Enable (SCE)</b> — R/W. 0 = An SERR# will Not be generated. 1 = An SERR# will be generated, assuming CMD.SEE (D28:F0/F1/F2/F3/F4/F5:04, bit 8) if a correctable error is reported by any of the devices in the hierarchy of this root port, including correctable errors in this root port.

### 18.1.35 RSTS—Root Status Register (PCI Express—D28:F0/F1/F2/F3/F4/F5)

Address Offset: 60h–63h                      Attribute: R/WC, RO  
Default Value: 00000000h                      Size: 32 bits

Bit	Description
31:18	Reserved
17	<b>PME Pending (PP)</b> — RO. 0 = When the original PME is cleared by software, it will be set again, the requestor ID will be updated, and this bit will be cleared. 1 = Another PME is pending when the PME status bit is set.
16	<b>PME Status (PS)</b> — R/WC. 0 = PME was not asserted. 1 = PME was asserted by the requestor ID in RID. Subsequent PMEs are kept pending until this bit is cleared.
15:0	<b>PME Requestor ID (RID)</b> — RO. This field indicates the PCI requestor ID of the last PME requestor. Valid only when PS is set.





### 18.1.36 MID—Message Signaled Interrupt Identifiers Register (PCI Express—D28:F0/F1/F2/F3/F4/F5)

Address Offset: 80h–81h                      Attribute: RO  
 Default Value: 9005h                        Size: 16 bits

Bit	Description
15:8	<b>Next Pointer (NEXT)</b> — RO. Indicates the location of the next pointer in the list.
7:0	<b>Capability ID (CID)</b> — RO. Capabilities ID indicates MSI.

### 18.1.37 MC—Message Signaled Interrupt Message Control Register (PCI Express—D28:F0/F1/F2/F3/F4/F5)

Address Offset: 82–83h                      Attribute: R/W, RO  
 Default Value: 0000h                        Size: 16 bits

Bit	Description
15:8	Reserved
7	<b>64 Bit Address Capable (C64)</b> — RO. Capable of generating a 32-bit message only.
6:4	<b>Multiple Message Enable (MME)</b> — R/W. These bits are R/W for software compatibility, but only one message is ever sent by the root port.
3:1	<b>Multiple Message Capable (MMC)</b> — RO. Only one message is required.
0	<b>MSI Enable (MSIE)</b> — R/W. 0 = Disabled. 1 = MSI is enabled and traditional interrupt pins are not used to generate interrupts.  <b>NOTE:</b> CMD.BME (D28:F0/F1/F2/F3/F4/F5:04h:bit 2) must be set for an MSI to be generated. If CMD.BME is cleared, and this bit is set, no interrupts (not even pin based) are generated.

### 18.1.38 MA—Message Signaled Interrupt Message Address Register (PCI Express—D28:F0/F1/F2/F3/F4/F5)

Address Offset: 84h–87h                      Attribute: R/W  
 Default Value: 00000000h                    Size: 32 bits

Bit	Description
31:2	<b>Address (ADDR)</b> — R/W. This field provides the lower 32 bits of the system specified message address, always DW aligned.
1:0	Reserved



### 18.1.39 MD—Message Signaled Interrupt Message Data Register (PCI Express—D28:F0/F1/F2/F3/F4/F5)

Address Offset: 88h–89h                      Attribute: R/W  
Default Value: 0000h                      Size: 16 bits

Bit	Description
15:0	<b>Data (DATA)</b> — R/W. This field is programmed by system software if MSI is enabled. Its content is driven onto the lower word (PCI AD[15:0]) during the data phase of the MSI memory write transaction.

### 18.1.40 SVCAP—Subsystem Vendor Capability Register (PCI Express—D28:F0/F1/F2/F3/F4/F5)

Address Offset: 90h–91h                      Attribute: RO  
Default Value: A00Dh                      Size: 16 bits

Bit	Description
15:8	<b>Next Capability (NEXT)</b> — RO. Indicates the location of the next pointer in the list.
7:0	<b>Capability Identifier (CID)</b> — RO. Value of 0Dh indicates this is a PCI bridge subsystem vendor capability.

### 18.1.41 SVID—Subsystem Vendor Identification Register (PCI Express—D28:F0/F1/F2/F3/F4/F5)

Address Offset: 94h–97h                      Attribute: R/WO  
Default Value: 00000000h                      Size: 32 bits

Bit	Description
31:16	<b>Subsystem Identifier (SID)</b> — R/WO. Indicates the subsystem as identified by the vendor. This field is write once and is locked down until a bridge reset occurs (not the PCI bus reset).
15:0	<b>Subsystem Vendor Identifier (SVID)</b> — R/WO. Indicates the manufacturer of the subsystem. This field is write once and is locked down until a bridge reset occurs (not the PCI bus reset).

### 18.1.42 PMCAP—Power Management Capability Register (PCI Express—D28:F0/F1/F2/F3/F4/F5)

Address Offset: A0h–A1h                      Attribute: RO  
Default Value: 0001h                      Size: 16 bits

Bit	Description
15:8	<b>Next Capability (NEXT)</b> — RO. Indicates this is the last item in the list.
7:0	<b>Capability Identifier (CID)</b> — RO. Value of 01h indicates this is a PCI power management capability.



### 18.1.43 PMC—PCI Power Management Capabilities Register (PCI Express—D28:F0/F1/F2/F3/F4/F5)

Address Offset: A2h–A3h  
Default Value: C802h

Attribute: RO  
Size: 16 bits

Bit	Description
15:11	PME_Support (PMES) — RO. Indicates PME# is supported for states D0, D3 <sub>HOT</sub> and D3 <sub>COLD</sub> . The root port does not generate PME#, but reporting that it does is necessary for some legacy operating systems to enable PME# in devices connected behind this root port.
10	D2_Support (D2S) — RO. The D2 state is not supported.
9	D1_Support (D1S) — RO. The D1 state is not supported.
8:6	Aux_Current (AC) — RO. Reports 375 mA maximum suspend well current required when in the D3 <sub>COLD</sub> state.
5	Device Specific Initialization (DSI) — RO. Indicates that no device-specific initialization is required.
4	Reserved
3	PME Clock (PMEC) — RO. Indicates that PCI clock is not required to generate PME#.
2:0	Version (VS) — RO. Indicates support for <i>Revision 1.1 of the PCI Power Management Specification</i> .



### 18.1.44 PMCS—PCI Power Management Control and Status Register (PCI Express—D28:F0/F1/F2/F3/F4/F5)

Address Offset: A4h–A7h                      Attribute: R/W, RO  
Default Value: 00000000h                      Size: 32 bits

Bit	Description
31:24	Reserved
23	Bus Power / Clock Control Enable (BPCE) — Reserved per <i>PCI Express* Base Specification, Revision 1.0a</i> .
22	B2/B3 Support (B23S) — Reserved per <i>PCI Express* Base Specification, Revision 1.0a</i> .
21:16	Reserved
15	<b>PME Status (PMES)</b> — RO. 0 = PME Not received. 1 = PME was received on the downstream link.
14:9	Reserved
8	<b>PME Enable (PMEE)</b> — R/W. The root port takes no action on this bit, but it must be R/W for some legacy operating systems to enable PME# on devices connected to this root port. This bit is sticky and resides in the resume well. The reset for this bit is RSMRST# which is not asserted during a warm reset. 0 = Disable 1 = Enable
7:2	Reserved
1:0	<b>Power State (PS)</b> — R/W. This field is used both to determine the current power state of the root port and to set a new power state. The values are: 00 = D0 state 11 = D3 <sub>HOT</sub> state <b>NOTE:</b> When in the D3 <sub>HOT</sub> state, the controller's configuration space is available, but the I/O and memory spaces are not. Type 1 configuration cycles are also not accepted. Interrupts are not required to be blocked as software will disable interrupts prior to placing the port into D3 <sub>HOT</sub> . If software attempts to write a '10' or '01' to these bits, the write will be ignored.





Bit	Description														
17:15	<b>Common Clock Exit Latency (CCEL)</b> — R/W. This value represents the L0s Exit Latency for common-clock configurations (LCTL.CCC = 1) (D28:F0/F1/F2/F3/F4/F5: Offset 50h: bit 6). It defaults to 128 ns to less than 256 ns, but may be overridden by BIOS.														
14:8	Reserved														
7	<p><b>Port I/OxApic Enable (PAE)</b> — R/W.</p> <p>0 = Hole is disabled.            1 = A range is opened through the bridge for the following memory addresses:</p> <table border="1"> <thead> <tr> <th>Port #</th> <th>Address</th> </tr> </thead> <tbody> <tr> <td>1</td> <td>FEC1_0000h – FEC1_7FFFh</td> </tr> <tr> <td>2</td> <td>FEC1_8000h – FEC1_FFFFh</td> </tr> <tr> <td>3</td> <td>FEC2_0000h – FEC2_7FFFh</td> </tr> <tr> <td>4</td> <td>FEC2_8000h – FEC2_FFFFh</td> </tr> <tr> <td>5</td> <td>FEC3_0000h – FEC3_7FFFh</td> </tr> <tr> <td>6</td> <td>FEC3_8000h – FEC3_FFFFh</td> </tr> </tbody> </table>	Port #	Address	1	FEC1_0000h – FEC1_7FFFh	2	FEC1_8000h – FEC1_FFFFh	3	FEC2_0000h – FEC2_7FFFh	4	FEC2_8000h – FEC2_FFFFh	5	FEC3_0000h – FEC3_7FFFh	6	FEC3_8000h – FEC3_FFFFh
Port #	Address														
1	FEC1_0000h – FEC1_7FFFh														
2	FEC1_8000h – FEC1_FFFFh														
3	FEC2_0000h – FEC2_7FFFh														
4	FEC2_8000h – FEC2_FFFFh														
5	FEC3_0000h – FEC3_7FFFh														
6	FEC3_8000h – FEC3_FFFFh														
6:3	Reserved														
2	<p><b>Bridge Type (BT)</b> — RO. This register can be used to modify the Base Class and Header Type fields from the default PCI-to-PCI bridge to a Host Bridge. Having the root port appear as a Host Bridge is useful in some server configurations.</p> <p>0 = The root port bridge type is a PCI-to-PCI Bridge, Header Sub-Class = 04h, and Header Type = Type 1.            1 = The root port bridge type is a PCI-to-PCI Bridge, Header Sub-Class = 00h, and Header Type = Type 0.</p>														
1	<p><b>Hot Plug SMI Enable (HPME)</b> — R/W.</p> <p>0 = Disable. SMI generation based on a Hot-Plug event is disabled.            1 = Enables the root port to generate SMI whenever a Hot-Plug event is detected.</p>														
0	<p><b>Power Management SMI Enable (PMME)</b> — R/W.</p> <p>0 = Disable. SMI generation based on a power management event is disabled.            1 = Enables the root port to generate SMI whenever a power management event is detected.</p>														





### 18.1.47 RPDCGEN—Root Port Dynamic Clock Gating Enable (PCI Express-D28:F0/F1/F2/F3/F4/F5) (Mobile Only)

Address Offset: E1h Attribute: R/W  
Default Value: 00h Size: 8-bits

Bits	Description
7:4	Reserved. RO
3	<b>Shared Resource Dynamic Link Clock Gating Enable (SRDLCGEN)</b> — RW. 1 = Enables dynamic clock gating on the root port shared resource link clock domain. 0 = Disables dynamic clock gating of the shared resource link clock domain. Only the value from Port 1 is used for ports 1–4. Only the value from Port 5 is used for ports 5-6.
2	<b>Shared Resource Dynamic Backbone Clock Gate Enable (SRDBCEN)</b> — RW. 1 = Enables dynamic clock gating on the root port shared resource backbone clock domain. 0 = Disables dynamic clock gating of the shared resource backbone clock domain. Only the value from Port 1 is used for ports 1–4. Only the value from Port 5 is used for ports 5-6.
1	<b>Root Port Dynamic Link Clock Gate Enable (RPDLCGEN)</b> — RW. 1 = Enables dynamic clock gating on the root port link clock domain. 0 = Disables dynamic clock gating of the root port link clock domain.
0	<b>Root Port Dynamic Backbone Clock Gate Enable (RPDBCEN)</b> — RW. 1 = Enables dynamic clock gating on the root port backbone clock domain. 0 = Disables dynamic clock gating of the root port backbone clock domain.

### 18.1.48 IPWS—Intel® PRO/Wireless 3945ABG Status (PCI Express—D28:F0/F1/F2/F3/F4/F5)

Address Offset: E2h–E3h Attribute: RO  
Default Value: 0007h Size: 16 bits

Bit	Description
15	<b>Intel PRO/Wireless 3945ABG Status (IPWSTAT)</b> — RO. This bit is set if the link has trained to LO in Intel PRO/Wireless 3945ABG mode.
14:0	Reserved





### 18.1.49 VCH—Virtual Channel Capability Header Register (PCI Express—D28:F0/F1/F2/F3/F4/F5)

Address Offset: 100h–103h                      Attribute: RO  
 Default Value: 18010002h                      Size: 32 bits

Bit	Description
31:20	Next Capability Offset (NCO) — RO. Indicates the next item in the list.
19:16	Capability Version (CV) — RO. Indicates this is version 1 of the capability structure by the PCI SIG.
15:0	Capability ID (CID) — RO. Indicates this is the Virtual Channel capability item.

### 18.1.50 VCAP2—Virtual Channel Capability 2 Register (PCI Express—D28:F0/F1/F2/F3/F4/F5)

Address Offset: 108h–10Bh                      Attribute: RO  
 Default Value: 00000001h                      Size: 32 bits

Bit	Description
31:24	VC Arbitration Table Offset (ATO) — RO. Indicates that no table is present for VC arbitration since it is fixed.
23:0	Reserved.

### 18.1.51 PVC—Port Virtual Channel Control Register (PCI Express—D28:F0/F1/F2/F3/F4/F5)

Address Offset: 10Ch–10Dh                      Attribute: R/W  
 Default Value: 0000h                              Size: 16 bits

Bit	Description
15:4	Reserved.
3:1	<b>VC Arbitration Select (AS)</b> — R/W. Indicates which VC should be programmed in the VC arbitration table. The root port takes no action on the setting of this field since there is no arbitration table.
0	<b>Load VC Arbitration Table (LAT)</b> — R/W. Indicates that the table programmed should be loaded into the VC arbitration table. This bit always returns 0 when read.

### 18.1.52 PVS — Port Virtual Channel Status Register (PCI Express—D28:F0/F1/F2/F3/F4/F5)

Address Offset: 10Eh–10Fh                      Attribute: RO  
 Default Value: 0000h                              Size: 16 bits

Bit	Description
15:1	Reserved.
0	<b>VC Arbitration Table Status (VAS)</b> — RO. Indicates the coherency status of the VC Arbitration table when it is being updated. This field is always 0 in the root port since there is no VC arbitration table.



### 18.1.53 VOCAP — Virtual Channel 0 Resource Capability Register (PCI Express—D28:F0/F1/F2/F3/F4/F5)

Address Offset: 110h–113h                      Attribute: RO  
Default Value: 00000001h                      Size: 32 bits

Bit	Description
31:24	Port Arbitration Table Offset (AT) — RO. This VC implements no port arbitration table since the arbitration is fixed.
23	Reserved.
22:16	Maximum Time Slots (MTS) — RO. This VC implements fixed arbitration, and therefore this field is not used.
15	Reject Snoop Transactions (RTS) — RO. This VC must be able to take snoopable transactions.
14	Advanced Packet Switching (APS) — RO. This VC is capable of all transactions, not just advanced packet switching transactions.
13:8	Reserved.
7:0	Port Arbitration Capability (PAC) — RO. Indicates that this VC uses fixed port arbitration.



### 18.1.54 VOCTL — Virtual Channel 0 Resource Control Register (PCI Express—D28:F0/F1/F2/F3/F4/F5)

Address Offset: 114h–117h                      Attribute: R/W, RO  
 Default Value: 80000FFh                      Size: 32 bits

Bit	Description																		
31	Virtual Channel Enable (EN) — RO. Always set to 1. Virtual Channel 0 cannot be disabled.																		
30:27	Reserved.																		
26:24	Virtual Channel Identifier (VCID) — RO. Indicates the ID to use for this virtual channel.																		
23:20	Reserved.																		
19:17	Port Arbitration Select (PAS) — R/W. Indicates which port table is being programmed. The root complex takes no action on this setting since the arbitration is fixed and there is no arbitration table.																		
16	Load Port Arbitration Table (LAT) — RO. The root port does not implement an arbitration table for this virtual channel.																		
15:8	Reserved.																		
7:1	<p><b>Transaction Class / Virtual Channel Map (TVM)</b> — R/W. This field indicates which transaction classes are mapped to this virtual channel. When a bit is set, this transaction class is mapped to the virtual channel.</p> <table border="1"> <thead> <tr> <th>Bit</th> <th>Transaction Class</th> </tr> </thead> <tbody> <tr> <td>7</td> <td>Transaction Class 7</td> </tr> <tr> <td>6</td> <td>Transaction Class 6</td> </tr> <tr> <td>5</td> <td>Transaction Class 5</td> </tr> <tr> <td>4</td> <td>Transaction Class 4</td> </tr> <tr> <td>3</td> <td>Transaction Class 3</td> </tr> <tr> <td>2</td> <td>Transaction Class 2</td> </tr> <tr> <td>1</td> <td>Transaction Class 1</td> </tr> <tr> <td>0</td> <td>Transaction Class 0</td> </tr> </tbody> </table>	Bit	Transaction Class	7	Transaction Class 7	6	Transaction Class 6	5	Transaction Class 5	4	Transaction Class 4	3	Transaction Class 3	2	Transaction Class 2	1	Transaction Class 1	0	Transaction Class 0
Bit	Transaction Class																		
7	Transaction Class 7																		
6	Transaction Class 6																		
5	Transaction Class 5																		
4	Transaction Class 4																		
3	Transaction Class 3																		
2	Transaction Class 2																		
1	Transaction Class 1																		
0	Transaction Class 0																		
0	Reserved. Transaction class 0 must always mapped to VC0.																		

### 18.1.55 VOSTS — Virtual Channel 0 Resource Status Register (PCI Express—D28:F0/F1/F2/F3/F4/F5)

Address Offset: 11Ah–11Bh                      Attribute: RO  
 Default Value: 0000h                      Size: 16 bits

Bit	Description
15:2	Reserved.
1	<p><b>VC Negotiation Pending (NP)</b> — RO.</p> <p>0 = Negotiation is Not pending.            1 = Indicates the Virtual Channel is still being negotiated with ingress ports.</p>
0	Port Arbitration Tables Status (ATS). There is no port arbitration table for this VC, so this bit is reserved as 0.





### 18.1.57 UEM — Uncorrectable Error Mask (PCI Express—D28:F0/F1/F2/F3/F4/F5)

Address Offset: 148h–14Bh                      Attribute: R/WO, RO  
 Default Value: 00000000h                      Size: 32 bits

When set, the corresponding error in the UES register is masked, and the logged error will cause no action. When cleared, the corresponding error is enabled.

Bit	Description
31:21	Reserved
20	<b>Unsupported Request Error Mask (URE)</b> — R/WO. 0 = The corresponding error in the UES register (D28:F0/F1/F2/F3/F4/F5:144) is enabled. 1 = The corresponding error in the UES register (D28:F0/F1/F2/F3/F4/F5:144) is masked.
19	ECRC Error Mask (EE) — RO. ECRC is not supported.
18	<b>Malformed TLP Mask (MT)</b> — R/WO. 0 = The corresponding error in the UES register (D28:F0/F1/F2/F3/F4/F5:144) is enabled. 1 = The corresponding error in the UES register (D28:F0/F1/F2/F3/F4/F5:144) is masked.
17	<b>Receiver Overflow Mask (RO)</b> — R/WO. 0 = The corresponding error in the UES register (D28:F0/F1/F2/F3/F4/F5:144) is enabled. 1 = The corresponding error in the UES register (D28:F0/F1/F2/F3/F4/F5:144) is masked.
16	<b>Unexpected Completion Mask (UC)</b> — R/WO. 0 = The corresponding error in the UES register (D28:F0/F1/F2/F3/F4/F5:144) is enabled. 1 = The corresponding error in the UES register (D28:F0/F1/F2/F3/F4/F5:144) is masked.
15	Completion Abort Mask (CA) — R/WO. 0 = The corresponding error in the UES register (D28:F0/F1/F2/F3/F4/F5:144) is enabled. 1 = The corresponding error in the UES register (D28:F0/F1/F2/F3/F4/F5:144) is masked.
14	<b>Completion Timeout Mask (CT)</b> — R/WO. 0 = The corresponding error in the UES register (D28:F0/F1/F2/F3/F4/F5:144) is enabled. 1 = The corresponding error in the UES register (D28:F0/F1/F2/F3/F4/F5:144) is masked.
13	Flow Control Protocol Error Mask (FCPE) — RO. Flow Control Protocol Errors not supported.
12	<b>Poisoned TLP Mask (PT)</b> — R/WO. 0 = The corresponding error in the UES register (D28:F0/F1/F2/F3/F4/F5:144) is enabled. 1 = The corresponding error in the UES register (D28:F0/F1/F2/F3/F4/F5:144) is masked.
11:5	Reserved
4	<b>Data Link Protocol Error Mask (DLPE)</b> — R/WO. 0 = The corresponding error in the UES register (D28:F0/F1/F2/F3/F4/F5:144) is enabled. 1 = The corresponding error in the UES register (D28:F0/F1/F2/F3/F4/F5:144) is masked.
3:1	Reserved
0	Training Error Mask (TE) — RO. Training Errors not supported



### 18.1.58 UEV — Uncorrectable Error Severity (PCI Express—D28:F0/F1/F2/F3/F4/F5)

Address Offset: 14Ch–14Fh  
Default Value: 00060011h

Attribute: RO  
Size: 32 bits

Bit	Description
31:21	Reserved
20	<b>Unsupported Request Error Severity (URE)</b> — RO. 0 = Error considered non-fatal. (Default) 1 = Error is fatal.
19	<b>ECRC Error Severity (EE)</b> — RO. ECRC is not supported.
18	<b>Malformed TLP Severity (MT)</b> — RO. 0 = Error considered non-fatal. 1 = Error is fatal. (Default)
17	<b>Receiver Overflow Severity (RO)</b> — RO. 0 = Error considered non-fatal. 1 = Error is fatal. (Default)
16	<b>Unexpected Completion Severity (UC)</b> — RO. 0 = Error considered non-fatal. (Default) 1 = Error is fatal.
15	<b>Completion Abort Severity (CA)</b> — RO. 0 = Error considered non-fatal. (Default) 1 = Error is fatal.
14	<b>Completion Timeout Severity (CT)</b> — RO. 0 = Error considered non-fatal. (Default) 1 = Error is fatal.
13	<b>Flow Control Protocol Error Severity (FCPE)</b> — RO. Flow Control Protocol Errors not supported.
12	<b>Poisoned TLP Severity (PT)</b> — RO. 0 = Error considered non-fatal. (Default) 1 = Error is fatal.
11:5	Reserved
4	<b>Data Link Protocol Error Severity (DLPE)</b> — RO. 0 = Error considered non-fatal. 1 = Error is fatal. (Default)
3:1	Reserved
0	<b>Training Error Severity (TE)</b> — RO. TE is not supported.



### 18.1.59 CES — Correctable Error Status Register (PCI Express—D28:F0/F1/F2/F3/F4/F5)

Address Offset: 150h–153h  
Default Value: 00000000h

Attribute: R/WC  
Size: 32 bits

Bit	Description
31:14	Reserved
13	<b>Advisory Non-Fatal Error Status (ANFES)</b> — R/WC. 0 = Advisory Non-Fatal Error did not occur. 1 = Advisory Non-Fatal Error did occur.
12	<b>Replay Timer Timeout Status (RTT)</b> — R/WC. 0 = No replay timer time out. 1 = Replay timer timed out occurred.
11:9	Reserved
8	<b>Replay Number Rollover Status (RNR)</b> — R/WC. 0 = Replay number did Not roll over. 1 = Replay number rolled over.
7	<b>Bad DLLP Status (BD)</b> — R/WC. 0 = Bad DLLP Not received. 1 = Bad DLLP was received.
6	<b>Bad TLP Status (BT)</b> — R/WC. 0 = Bad TLP Not received. 1 = Bad TLP was received.
5:1	Reserved
0	<b>Receiver Error Status (RE)</b> — R/WC. 0 = Receiver error did Not occurred. 1 = Receiver error occurred.



### 18.1.60 CEM — Correctable Error Mask Register (PCI Express—D28:F0/F1/F2/F3/F4/F5)

Address Offset: 154h–157h                      Attribute: R/WO  
 Default Value: 00000000h                      Size: 32 bits

When set, the corresponding error in the CES register is masked, and the logged error will cause no action. When cleared, the corresponding error is enabled.

Bit	Description
31:14	Reserved
13	<b>Advisory Non-Fatal Error Mask (ANFEM)</b> — R/WO. 0 = Does not mask Advisory Non-Fatal errors. 1 = Masks Advisory Non-Fatal errors from (a) signaling ERR_COR to the device control register and (b) updating the Uncorrectable Error Status register. This register is set by default to enable compatibility with software that does not comprehend Role-Based Error Reporting.
12	<b>Replay Timer Timeout Mask (RTT)</b> — R/WO. Mask for replay timer timeout.
11:9	Reserved
8	<b>Replay Number Rollover Mask (RNR)</b> — R/WO. Mask for replay number rollover.
7	<b>Bad DLLP Mask (BD)</b> — R/WO. Mask for bad DLLP reception.
6	<b>Bad TLP Mask (BT)</b> — R/WO. Mask for bad TLP reception.
5:1	Reserved
0	<b>Receiver Error Mask (RE)</b> — R/WO. Mask for receiver errors.

### 18.1.61 AECC — Advanced Error Capabilities and Control Register (PCI Express—D28:F0/F1/F2/F3/F4/F5)

Address Offset: 158h–15Bh                      Attribute: RO  
 Default Value: 00000000h                      Size: 32 bits

Bit	Description
31:9	Reserved
8	<b>ECRC Check Enable (ECE)</b> — RO. ECRC is not supported.
7	<b>ECRC Check Capable (ECC)</b> — RO. ECRC is not supported.
6	<b>ECRC Generation Enable (EGE)</b> — RO. ECRC is not supported.
5	<b>ECRC Generation Capable (EGC)</b> — RO. ECRC is not supported.
4:0	<b>First Error Pointer (FEP)</b> — RO.





### 18.1.62 RES — Root Error Status Register (PCI Express—D28:F0/F1/F2/F3/F4/F5)

Address Offset: 170h–173h                      Attribute: R/WC, RO  
 Default Value: 00000000h                      Size: 32 bits

Bit	Description
31:27	Advanced Error Interrupt Message Number (AEMN) — RO. There is only one error interrupt allocated.
26:4	Reserved
3	<b>Multiple ERR_FATAL/NONFATAL Received (MENR)</b> — RO. For Intel® ICH8, only one error will be captured.
2	<b>ERR_FATAL/NONFATAL Received (ENR)</b> — R/WC. 0 = No error message received. 1 = Either a fatal or a non-fatal error message is received.
1	<b>Multiple ERR_COR Received (MCR)</b> — RO. For ICH8, only one error will be captured.
0	<b>ERR_COR Received (CR)</b> — R/WC. 0 = No error message received. 1 = A correctable error message is received.

### 18.1.63 RCTCL — Root Complex Topology Capability List Register (PCI Express—D28:F0/F1/F2/F3/F4/F5)

Address Offset: 180–183h                      Attribute: RO  
 Default Value: 00010005h                      Size: 32 bits

Bit	Description
31:20	<b>Next Capability (NEXT)</b> — RO. Indicates the next item in the list, in this case, end of list.
19:16	<b>Capability Version (CV)</b> — RO. Indicates the version of the capability structure.
15:0	<b>Capability ID (CID)</b> — RO. Indicates this is a root complex topology capability.



### 18.1.64 ESD – Element Self Description Register (PCI Express—D28:F0/F1/F2/F3/F4/F5)

Address Offset: 184h–187h                      Attribute: RO  
 Default Value: See Description                Size: 32 bits

Bit	Description														
31:24	<p><b>Port Number (PN)</b> — RO. This field indicate the ingress port number for the root port. There is a different value per port:</p> <table border="1"> <thead> <tr> <th>Port #</th> <th>Value</th> </tr> </thead> <tbody> <tr> <td>1</td> <td>01h</td> </tr> <tr> <td>2</td> <td>02h</td> </tr> <tr> <td>3</td> <td>03h</td> </tr> <tr> <td>4</td> <td>04h</td> </tr> <tr> <td>5</td> <td>05h</td> </tr> <tr> <td>6</td> <td>06h</td> </tr> </tbody> </table>	Port #	Value	1	01h	2	02h	3	03h	4	04h	5	05h	6	06h
Port #	Value														
1	01h														
2	02h														
3	03h														
4	04h														
5	05h														
6	06h														
23:16	<p><b>Component ID (CID)</b> — RO. This field returns the value of the ESD.CID field (Chipset Config Space: Offset 0104h:bits 23:16) of the chip configuration section, that is programmed by platform BIOS, since the root port is in the same component as the RCRB.</p>														
15:8	<p><b>Number of Link Entries (NLE)</b> — RO. (Default value is 01h) Indicates one link entry (corresponding to the RCRB).</p>														
7:4	Reserved.														
3:0	<p><b>Element Type (ET)</b> — RO. (Default value is 0h) Indicates that the element type is a root port.</p>														

### 18.1.65 ULD – Upstream Link Description Register (PCI Express—D28:F0/F1/F2/F3/F4/F5)

Address Offset: 190h–193h                      Attribute: RO  
 Default Value: 00000001h                      Size: 32 bits

Bit	Description
31:24	<p><b>Target Port Number (PN)</b> — RO. Indicates the port number of the RCRB.</p>
23:16	<p><b>Target Component ID (TCID)</b> — RO. This field returns the value of the ESD.CID field (Chipset Configuration Space: Offset 0104h, bits 23:16) of the chip configuration section, that is programmed by platform BIOS, since the root port is in the same component as the RCRB.</p>
15:2	Reserved.
1	<p><b>Link Type (LT)</b> — RO. Indicates that the link points to the Intel® ICH8 RCRB.</p>
0	<p><b>Link Valid (LV)</b> — RO. Indicates that this link entry is valid.</p>







# 19 High Precision Event Timer Registers

The timer registers are memory-mapped in a non-indexed scheme. This allows the processor to directly access each register without having to use an index register. The timer register space is 1024 bytes. The registers are generally aligned on 64-bit boundaries to simplify implementation with IA64 processors. There are four possible memory address ranges beginning at 1) FED0\_0000h, 2) FED0\_1000h, 3) FED0\_2000h., 4) FED0\_4000h. The choice of address range will be selected by configuration bits in the High Precision Timer Configuration Register (Chipset Configuration Registers: Offset 3404h).

Behavioral Rules:

1. Software must not attempt to read or write across register boundaries. For example, a 32-bit access should be to offset x0h, x4h, x8h, or xCh. 32-bit accesses should not be to 01h, 02h, 03h, 05h, 06h, 07h, 09h, 0Ah, 0Bh, 0Dh, 0Eh, or 0Fh. Any accesses to these offsets will result in an unexpected behavior, and may result in a master abort. However, these accesses should not result in system hangs. 64-bit accesses can only be to x0h and must not cross 64-bit boundaries.
2. Software should not write to read only registers.
3. Software should not expect any particular or consistent value when reading reserved registers or bits.

## 19.1 Memory-Mapped Registers

Table 142. Memory-Mapped Registers (Sheet 1 of 2)

Offset	Mnemonic	Register	Default	Type
000–007h	GCAP_ID	General Capabilities and Identification	0429B17F8 086A201h	RO
008–00Fh	—	Reserved	—	—
010–017h	GEN_CONF	General Configuration	0000h	R/W
018–01Fh	—	Reserved	—	—
020–027h	GINTR_STA	General Interrupt Status	00000000 00000000h	R/WC, R/W
028–0EFh	—	Reserved	—	—
0F0–0F7h	MAIN_CNT	Main Counter Value	N/A	R/W
0F8–0FFh	—	Reserved	—	—
100–107h	TIMO_CONF	Timer 0 Configuration and Capabilities	N/A	R/W, RO
108–10Fh	TIMO_COMP	Timer 0 Comparator Value	N/A	R/W
110–11Fh	—	Reserved	—	—
120–127h	TIM1_CONF	Timer 1 Configuration and Capabilities	N/A	R/W, RO
128–12Fh	TIM1_COMP	Timer 1 Comparator Value	N/A	R/W
130–13Fh	—	Reserved	—	—





### 19.1.2 GEN\_CONF—General Configuration Register

Address Offset: 010h                      Attribute: R/W  
 Default Value: 00000000 00000000h      Size: 64 bits

Bit	Description
63:2	Reserved. These bits return 0 when read.
1	<p><b>Legacy Replacement Rout (LEG_RT_CNF)</b> — R/W. If the ENABLE_CNF bit and the LEG_RT_CNF bit are both set, then the interrupts will be routed as follows:</p> <ul style="list-style-type: none"> <li>• Timer 0 is routed to IRQ0 in 8259 or IRQ2 in the I/O APIC</li> <li>• Timer 1 is routed to IRQ8 in 8259 or IRQ8 in the I/O APIC</li> <li>• Timer 2-n is routed as per the routing in the timer n config registers.</li> <li>• If the Legacy Replacement Rout bit is set, the individual routing bits for Timers 0 and 1 (APIC) will have no impact.</li> <li>• If the Legacy Replacement Rout bit is not set, the individual routing bits for each of the timers are used.</li> <li>• This bit will default to 0. BIOS can set it to 1 to enable the legacy replacement routing, or 0 to disable the legacy replacement routing.</li> </ul>
0	<p><b>Overall Enable (ENABLE_CNF)</b> — R/W. This bit must be set to enable any of the timers to generate interrupts. If this bit is 0, then the main counter will halt (will not increment) and no interrupts will be caused by any of these timers. For level-triggered interrupts, if an interrupt is pending when the ENABLE_CNF bit is changed from 1 to 0, the interrupt status indications (in the various Txx_INT_STS bits) will not be cleared. Software must write to the Txx_INT_STS bits to clear the interrupts.</p> <p><b>NOTE:</b> This bit will default to 0. BIOS can set it to 1 or 0.</p>

### 19.1.3 GINTR\_STA—General Interrupt Status Register

Address Offset: 020h                      Attribute: R/W, R/WC  
 Default Value: 00000000 00000000h      Size: 64 bits

Bit	Description
63:3	Reserved. These bits will return 0 when read.
2	<b>Timer 2 Interrupt Active (T02_INT_STS)</b> — R/W. Same functionality as Timer 0.
1	<b>Timer 1 Interrupt Active (T01_INT_STS)</b> — R/W. Same functionality as Timer 0.
0	<p><b>Timer 0 Interrupt Active (T00_INT_STS)</b> — R/WC. The functionality of this bit depends on whether the edge or level-triggered mode is used for this timer. (default = 0).</p> <p>If set to level-triggered mode:          This bit will be set by hardware if the corresponding timer interrupt is active. Once the bit is set, it can be cleared by software writing a 1 to the same bit position. Writes of 0 to this bit will have no effect.</p> <p>If set to edge-triggered mode:          This bit should be ignored by software. Software should always write 0 to this bit.</p> <p><b>NOTE:</b> Defaults to 0. In edge triggered mode, this bit will always read as 0 and writes will have no effect.</p>







Bit	Description
8	<p><b>Timer n 32-bit Mode (TIMERn_32MODE_CNF)</b> — R/W or RO. Software can set this bit to force a 64-bit timer to behave as a 32-bit timer.</p> <p>Timer 0: Bit is read/write (default to 0). 0 = 64 bit; 1 = 32 bit</p> <p>Timers 1, 2: Hardwired to 0. Writes have no effect (since these two timers are 32-bits).</p> <p><b>NOTE:</b> When this bit is set to '1', the hardware counter will do a 32-bit operation on comparator match and rollovers, thus the upper 32-bit of the Timer 0 Comparator Value register is ignored. The upper 32-bit of the main counter is not involved in any rollover from lower 32-bit of the main counter and becomes all zeros.</p>
7	Reserved. This bit returns 0 when read.
6	<p><b>Timer n Value Set (TIMERn_VAL_SET_CNF)</b> — R/W. Software uses this bit only for Timer 0 if it has been set to periodic mode. By writing this bit to a 1, the software is then allowed to directly set the timer's accumulator. Software does <b>not</b> have to write this bit back to 1 (it automatically clears).</p> <p>Software should not write a 1 to this bit position if the timer is set to non-periodic mode.</p> <p><b>NOTE:</b> This bit will return 0 when read. Writes will only have an effect for Timer 0 if it is set to periodic mode. Writes will have no effect for Timers 1 and 2.</p>
5	<p><b>Timer n Size (TIMERn_SIZE_CAP)</b> — RO. This read only field indicates the size of the timer.</p> <p>Timer 0: Value is 1 (64-bits).</p> <p>Timers 1, 2: Value is 0 (32-bits).</p>
4	<p><b>Periodic Interrupt Capable (TIMERn_PER_INT_CAP)</b> — RO. If this bit is 1, the hardware supports a periodic mode for this timer's interrupt.</p> <p>Timer 0: Hardwired to 1 (supports the periodic interrupt).</p> <p>Timers 1, 2: Hardwired to 0 (does not support periodic interrupt).</p>
3	<p><b>Timer n Type (TIMERn_TYPE_CNF)</b> — R/W or RO.</p> <p>Timer 0: Bit is read/write. 0 = Disable timer to generate periodic interrupt; 1 = Enable timer to generate a periodic interrupt.</p> <p>Timers 1, 2: Hardwired to 0. Writes have no affect.</p>
2	<p><b>Timer n Interrupt Enable (TIMERn_INT_ENB_CNF)</b> — R/W. This bit must be set to enable timer n to cause an interrupt when it times out.</p> <p>1 = Enable.</p> <p>0 = Disable (Default). The timer can still count and generate appropriate status bits, but will not cause an interrupt.</p>
1	<p><b>Timer Interrupt Type (TIMERn_INT_TYPE_CNF)</b> — R/W.</p> <p>0 = The timer interrupt is edge triggered. This means that an edge-type interrupt is generated. If another interrupt occurs, another edge will be generated.</p> <p>1 = The timer interrupt is level triggered. This means that a level-triggered interrupt is generated. The interrupt will be held active until it is cleared by writing to the bit in the General Interrupt Status Register. If another interrupt occurs before the interrupt is cleared, the interrupt will remain active.</p>
0	Reserved. These bits will return 0 when read.

**NOTE:** Reads or writes to unimplemented timers should not be attempted. Read from any unimplemented registers will return an undetermined value.





## 20 Serial Peripheral Interface (SPI)

The Serial Peripheral Interface resides in memory-mapped space. This function contains registers that allow for the setup and programming of devices that reside on the SPI interface.

**Note:** All registers in this function (including memory-mapped registers) must be addressable in byte, word, and dword quantities. The software must always make register accesses on natural boundaries (i.e., DWord accesses must be on DWord boundaries; word accesses on word boundaries, etc.) In addition, the memory-mapped register space must not be accessed with the LOCK semantic exclusive-access mechanism. If software attempts exclusive-access mechanisms to the SPI memory-mapped space, the results are undefined.

### 20.1 Serial Peripheral Interface Memory-Mapped Configuration Registers

The SPI Host Interface registers are memory-mapped in the RCRB Chipset Register Space with a base address (SPIBAR) of 3020h and are located within the range of 3020h to 30FFh. The individual registers are then accessible at SPIBAR + Offset as indicated in [Table 143](#).

These memory mapped registers must be accessed in byte, word, or DWord quantities.

**Table 143. Serial Peripheral Interface (SPI) Register Address Map (SPI Memory Mapped Configuration Registers) (Sheet 1 of 2)**

SPIBAR + Offset	Mnemonic	Register Name	Default	Access
00h–03h	BFPR	BIOS Flash Primary Region	00000000h	RO
04h–05h	HSFS	Hardware Sequencing Flash Status	0000h	RO, R/WC, R/WL
06h–07h	HSFC	Hardware Sequencing Flash Control	0000h	R/W, R/WS
08h–0Bh	FADDR	Flash Address	00000000h	R/W
0Ch–0Fh	—	Reserved	00000000h	—
10h–13h	FDATA0	Flash Data 0	00000000h	R/W
14h–4Fh	FDATAN	Flash Data N	00000000h	R/W
50h–53h	FRACC	Flash Region Access Permissions	00000000h	RO, R/WL
54h–57h	FREG0	Flash Region 0	00000000h	RO
58h–5Bh	FREG1	Flash Region 1	00000000h	RO
5Ch–5F	FREG2	Flash Region 2	00000000h	RO
60h–63h	FREG3	Flash Region 3	00000000h	RO
64h–73h	—	Reserved	—	—
74h–77h	FPRO	Flash Protected Range 0	00000000h	R/WL



**Table 143. Serial Peripheral Interface (SPI) Register Address Map (SPI Memory Mapped Configuration Registers) (Sheet 2 of 2)**

SPIBAR + Offset	Mnemonic	Register Name	Default	Access
78h–7Bh	FPR1	Flash Protected Range 1	00000000h	R/WL
7Ch–7Fh	FPR2	Flash Protected Range 2	00000000h	R/WL
80–83h	FPR3	Flash Protected Range 3	00000000h	R/WL
84h–87h	FPR4	Flash Protected Range 4	00000000h	R/WL
88h–8Fh	—	Reserved	—	—
90h	SSFS	Software Sequencing Flash Status	0000h	RO, R/WC
91h–93h	SSFC	Software Sequencing Flash Control	0000h	R/W
94h–95h	PREOP	Prefix Opcode Configuration	0000h	R/WL
96h–97h	OPTYPE	Opcode Type Configuration	0000h	R/W
98h–9Fh	OPMENU	Opcode Menu Configuration	00000000 00000000h	R/W
B0h–B3h	FDOC	Flash Descriptor Observability Control	00000000h	R/W
B4h–B7h	FDOD	Flash Descriptor Observability Data	00000000h	RO
B8h–DFh	—	Reserved	—	—
C1h–C4h	VSCC	Vendor Specific Component Capabilities	00000000h	RO, R/WL

### 20.1.1 BFPR—BIOS Flash Primary Region Register (SPI Memory Mapped Configuration Registers)

Memory Address: SPIBAR + 00h  
 Default Value: 00000000h

Attribute: RO  
 Size: 32 bits

Bit	Description
31:29	Reserved
28:16	<b>BIOS Flash Primary Region Limit (PRL)</b> — RO. This field specifies address bits 24:12 for the Primary Region Limit. The value in this register loaded from the contents in the Flash Descriptor.FLREG1.Region Limit.
15:13	Reserved
12:0	<b>BIOS Flash Primary Region Base (PRB)</b> — RO. This field specifies address bits 24:12 for the Primary Region Base The value in this register is loaded from the contents in the Flash Descriptor.FLREG1.Region Base.



## 20.1.2 HSFS—Hardware Sequencing Flash Status Register (SPI Memory Mapped Configuration Registers)

Memory Address: SPIBAR + 04h  
Default Value: 0000h

Attribute: RO, R/WC, R/WL  
Size: 16 bits

Bit	Description
15	<p><b>Flash Configuration Lock-Down (FLOCKDN)</b>— R/W/L. When set to 1, the Flash Program Registers that are locked down by this FLOCKDN bit cannot be written. Once set to 1, this bit can only be cleared by a hardware reset.</p> <p>Hardware reset is initiated by one of the following resets:</p> <ul style="list-style-type: none"> <li>Global reset (when the Host and the ME partitions are both reset) - on both ME-enabled and non-ME systems.</li> <li>Host Partition reset (any time PLTRST# is asserted either from a cold or a warm reset) - only on ME enabled systems.</li> </ul>
14	<p><b>Flash Descriptor Valid (FDV)</b>— RO. This bit is set to a 1 if the Flash Controller read the correct Flash Descriptor Signature.</p> <p>If the Flash Descriptor Valid bit is not 1, software cannot use the Hardware Sequencing registers, but must use the software sequencing registers. Any attempt to use the Hardware Sequencing registers will result in the FCERR bit being set.</p>
13	<p><b>Flash Descriptor Override Pin-Strap Status (FDOPSS)</b> — RO: This bit reflects the value the Flash Descriptor Override Pin-Strap.</p> <p>0 = The Flash Descriptor Override strap is set 1 = No override</p>
12:6	Reserved
5	<p><b>SPI Cycle In Progress (SCIP)</b>— RO. Hardware sets this bit when software sets the Flash Cycle Go (FGO) bit in the Hardware Sequencing Flash Control register. This bit remains set until the cycle completes on the SPI interface. Hardware automatically sets and clears this bit so that software can determine when read data is valid and/or when it is safe to begin programming the next command. Software must only program the next command when this bit is 0.</p>
4:3	<p><b>Block/Sector Erase Size (BERASE)</b> — RO. This field identifies the erasable sector size for all Flash components.</p> <p>Valid Bit Settings:</p> <p>00 = 256 Byte 01 = 4 KB 10 = Reserved for future use 11 = 64 KB</p>
2	<p><b>Access Error Log (AEL)</b>— R/W/C. Hardware sets this bit to a 1 when an attempt was made to access the BIOS region using the direct access method or an access to the BIOS Program Registers that violated the security restrictions. This bit is simply a log of an access security violation. This bit is cleared by software writing a 1.</p>
1	<p><b>Flash Cycle Error (FCERR)</b> — R/W/C. Hardware sets this bit to 1 when an program register access is blocked to the FLASH due to one of the protection policies or when any of the programmed cycle registers is written while a programmed access is already in progress. This bit remains asserted until cleared by software writing a 1 or until hardware reset occurs. Software must clear this bit before setting the FLASH Cycle GO bit in this register.</p> <p>Hardware reset is initiated by one of the following resets:</p> <ul style="list-style-type: none"> <li>Global reset (when the Host and the ME partitions are both reset) - on both ME-enabled and non-ME systems.</li> <li>Host Partition reset (any time PLTRST# is asserted either from a cold or a warm reset) - only on ME enabled systems.</li> </ul>



Bit	Description
0	<p><b>Flash Cycle Done (FDONE)</b> — R/W/C. The ICH8 sets this bit to 1 when the SPI Cycle completes after software previously set the FGO bit. This bit remains asserted until cleared by software writing a 1 or hardware reset. When this bit is set and the SPI SMI# Enable bit is set, an internal signal is asserted to the SMI# generation block. Software must make sure this bit is cleared prior to enabling the SPI SMI# assertion for a new programmed access.</p> <p>Hardware reset is initiated by one of the following resets:</p> <ul style="list-style-type: none"> <li>• Global reset (when the Host and the ME partitions are both reset) - on both ME-enabled and non-ME systems.</li> <li>• Host Partition reset (any time PLTRST# is asserted either from a cold or a warm reset) - only on ME enabled systems.</li> </ul>

### 20.1.3 HSFC—Hardware Sequencing Flash Control Register (SPI Memory Mapped Configuration Registers)

Memory Address: SPIBAR + 06h  
 Default Value: 0000h

Attribute: R/W, R/WS  
 Size: 16 bits

Bit	Description
15	<b>Flash SPI SMI# Enable (FSMIE)</b> : — R/W. When set to 1, the SPI asserts an SMI# request whenever the Flash Cycle Done bit is 1.
14	Reserved
13:8	<b>Flash Data Byte Count (FDBC)</b> : — R/W. This field specifies the number of bytes to shift in or out during the data portion of the SPI cycle. The contents of this register are 0's based with 0b representing 1 byte and 111111b representing 64 bytes. The number of bytes transferred is the value of this field plus 1. This field is ignored for the Block Erase command.
7:3	Reserved
2:1	<b>FLASH Cycle (FCYCLE)</b> . — R/W. This field defines the Flash SPI cycle type generated to the FLASH when the FGO bit is set as defined below: 00 = Read (1 up to 64 bytes by setting FDBC) 01 = Reserved 10 = Write (1 up to 64 bytes by setting FDBC) 11 = Block Erase
0	<b>Flash Cycle Go (FGO)</b> : — R/W/S. A write to this register with a 1 in this bit initiates a request to the Flash SPI Arbiter to start a cycle. This register is cleared by hardware when the cycle is granted by the SPI arbiter to run the cycle on the SPI bus. When the cycle is complete, the FDONE bit is set. Software is forbidden to write to any register in the HSFLCTL register between the FGO bit getting set and the FDONE bit being cleared. Any attempt to violate this rule will be ignored by hardware. Hardware allows other bits in this register to be programmed for the same transaction when writing this bit to 1. This saves an additional memory write. This bit always returns 0 on reads.



### 20.1.4 FADDR—Flash Address Register (SPI Memory Mapped Configuration Registers)

Memory Address: SPIBAR + 08h                      Attribute:                      R/W  
 Default Value: 00000000h                      Size:                      32 bits

Bit	Description
31:25	Reserved
24:0	<b>Flash Linear Address (FLA):</b> — R/W. The FLA is the starting byte linear address of a SPI Read or Write cycle or an address within a Block for the Block Erase command. The Flash Linear Address must fall within a region for which BIOS has access permissions. Hardware must convert the FLA into a Flash Physical Address (FPA) before running this cycle on the SPI bus.

### 20.1.5 FDATA0—Flash Data 0 Register (SPI Memory Mapped Configuration Registers)

Memory Address: SPIBAR + 10h                      Attribute:                      R/W  
 Default Value: 00000000h                      Size:                      32 bits

Bit	Description
31:0	<b>Flash Data 0 (FDO):</b> — R/W. This field is shifted out as the SPI Data on the Master-Out Slave-In Data pin during the data portion of the SPI cycle. This register also shifts in the data from the Master-In Slave-Out pin into this register during the data portion of the SPI cycle. The data is always shifted starting with the least significant byte, msb to lsb, followed by the next least significant byte, msb to lsb, etc. Specifically, the shift order on SPI in terms of bits within this register is: 7-6-5-4-3-2-1-0-15-14-13-...8-23-22-...16-31-...24. Bit 24 is the last bit shifted out/in. There are no alignment assumptions; byte 0 always represents the value specified by the cycle address. Note that the data in this register may be modified by the hardware during any programmed SPI transaction. Direct Memory Reads do not modify the contents of this register.

### 20.1.6 FDATAN—Flash Data [N] Register (SPI Memory Mapped Configuration Registers)

Memory Address: SPIBAR + 14h                      Attribute:                      R/W  
                          SPIBAR + 18h  
                          SPIBAR + 1Ch  
                          SPIBAR + 20h  
                          SPIBAR + 24h  
                          SPIBAR + 28h  
                          SPIBAR + 2Ch  
                          SPIBAR + 30h  
                          SPIBAR + 34h  
                          SPIBAR + 38h  
                          SPIBAR + 3Ch  
                          SPIBAR + 40h  
                          SPIBAR + 44h  
                          SPIBAR + 48h  
                          SPIBAR + 4Ch  
 Default Value: 00000000h                      Size:                      32 bits

Bit	Description
31:0	<b>Flash Data N (FD[N]):</b> — R/W. Similar definition as Flash Data 0. However, this register does not begin shifting until FD[N-1] has completely shifted in/out.



### 20.1.7 FRAP—Flash Regions Access Permissions Register (SPI Memory Mapped Configuration Registers)

Memory Address: SPIBAR + 50h                      Attribute:                      RO, R/WL  
 Default Value: 00000202h                      Size:                      32 bits

Bit	Description
31:24	<b>BIOS Master Write Access Grant (BMWAG):</b> — R/WL. Each bit [31:29] corresponds to Master[7:0]. BIOS can grant one or more masters write access to the BIOS region 1 overriding the permissions in the Flash Descriptor. Master[1] is Host CPU/BIOS, Master[2] is ME, Master[3] is Host CPU/GbE. Master[0] and Master[7:4] are reserved. The contents of this register are locked by the FLOCKDN bit.
23:16	<b>BIOS Master Read Access Grant (BMRAG):</b> — R/WL. Each bit [28:16] corresponds to Master[7:0]. BIOS can grant one or more masters read access to the BIOS region 1 overriding the read permissions in the Flash Descriptor. Master[1] is Host CPU/BIOS, Master[2] is ME, Master[3] is Host CPU/GbE. Master[0] and Master[7:4] are reserved. The contents of this register are locked by the FLOCKDN bit
15:8	<b>BIOS Region Write Access (BRWA):</b> — RO. Each bit [15:8] corresponds to Regions [7:0]. If the bit is set, this master can erase and write that particular region through register accesses. The contents of this register are that of the Flash Descriptor. Flash Master 1 Master Region Write Access OR a particular master has granted BIOS write permissions in their Master Write Access Grant register or the Flash Descriptor Security Override strap is set.
7:0	<b>BIOS Region Read Access (BRRA):</b> — RO. Each bit [7:0] corresponds to Regions [7:0]. If the bit is set, this master can read that particular region through register accesses. The contents of this register are that of the Flash Descriptor. Flash Master 1. Master Region Write Access OR a particular master has granted BIOS read permissions in their Master Read Access Grant register or the Flash Descriptor Security Override strap is set.

### 20.1.8 FREG0—Flash Region 0 (Flash Descriptor) Register (SPI Memory Mapped Configuration Registers)

Memory Address: SPIBAR + 54h                      Attribute:                      RO  
 Default Value: 00000000h                      Size:                      32 bits

Bit	Description
31:29	Reserved
28:16	<b>Region Limit (RL):</b> — RO. This field specifies address bits 24:12 for the Region 0 Limit. The value in this register is loaded from the contents in the Flash Descriptor.FLREG0.Region Limit
15:13	Reserved
12:0	<b>Region Base (RB) / Flash Descriptor Base Address Region (FDBAR):</b> — RO. This field specifies address bits 24:12 for the Region 0 Base. The value in this register is loaded from the contents in the Flash Descriptor.FLREG0.Region Base





## 20.1.9 FREG1—Flash Region 1 (BIOS Descriptor) Register (SPI Memory Mapped Configuration Registers)

Memory Address: SPIBAR + 58h                      Attribute:                      RO  
 Default Value: 00000000h                      Size:                              32 bits

Bit	Description
31:29	Reserved
28:16	<b>Region Limit (RL):</b> — RO. This field specifies address bits 24:12 for the Region 1 Limit. The value in this register is loaded from the contents in the Flash Descriptor.FLREG1.Region Limit.
15:13	Reserved
12:0	<b>Region Base (RB):</b> — RO. This field specifies address bits 24:12 for the Region 1 Base. The value in this register is loaded from the contents in the Flash Descriptor.FLREG1.Region Base.

## 20.1.10 FREG2—Flash Region 2 (ME) Register (SPI Memory Mapped Configuration Registers)

Memory Address: SPIBAR + 5Ch                      Attribute:                      RO  
 Default Value: 00000000h                      Size:                              32 bits

Bit	Description
31:29	Reserved
28:16	<b>Region Limit (RL):</b> — RO. This field specifies address bits 24:12 for the Region 2 Limit. The value in this register is loaded from the contents in the Flash Descriptor.FLREG2.Region Limit.
15:13	Reserved
12:0	<b>Region Base (RB):</b> — RO. This field specifies address bits 24:12 for the Region 2 Base The value in this register is loaded from the contents in the Flash Descriptor.FLREG2.Region Base.



### 20.1.11 FREG3—Flash Region 3 (GbE) Register (SPI Memory Mapped Configuration Registers)

Memory Address: SPIBAR + 60h                      Attribute:                      RO  
 Default Value: 00000000h                      Size:                      32 bits

Bit	Description
31:29	Reserved
28:16	<b>Region Limit (RL):</b> — RO. This field specifies address bits 24:12 for the Region 3 Limit. The value in this register is loaded from the contents in the Flash Descriptor.FLREG3.Region Limit.
15:13	Reserved
12:0	<b>Region Base (RB):</b> — RO. This specifies address bits 24:12 for the Region 3 Base The value in this register is loaded from the contents in the Flash Descriptor.FLREG3.Region Base.

### 20.1.12 PR0—Protected Range 0 Register (SPI Memory Mapped Configuration Registers)

Memory Address: SPIBAR + 74h                      Attribute:                      R/WL  
 Default Value: 00000000h                      Size:                      32 bits

**Note:** This register can not be written when the FLOCKDN bit is set to 1.

Bit	Description
31	<b>Write Protection Enable:</b> — R/WL. When set, this bit indicates that the Base and Limit fields in this register are valid and that writes and erases directed to addresses between them (inclusive) must be blocked by hardware. The base and limit fields are ignored when this bit is cleared.
30:29	Reserved
28:16	<b>Protected Range Limit:</b> — R/WL. This field corresponds to FLA address bits 24:12 and specifies the upper limit of the protected range. Address bits 11:0 are assumed to be FFFh for the limit comparison. Any address greater than the value programmed in this field is unaffected by this protected range.
15	<b>Read Protection Enable:</b> — R/WL. When set, this bit indicates that the Base and Limit fields in this register are valid and that read directed to addresses between them (inclusive) must be blocked by hardware. The base and limit fields are ignored when this bit is cleared.
14:13	Reserved
12:0	<b>Protected Range Base:</b> — R/WL. This field corresponds to FLA address bits 24:12 and specifies the lower base of the protected range. Address bits 11:0 are assumed to be 000h for the base comparison. Any address less than the value programmed in this field is unaffected by this protected range.



### 20.1.13 PR1—Protected Range 1 Register (SPI Memory Mapped Configuration Registers)

Memory Address: SPIBAR + 78h  
Default Value: 00000000h

Attribute: R/WL  
Size: 32 bits

**Note:** This register can not be written when the FLOCKDN bit is set to 1.

Bit	Description
31	<b>Write Protection Enable:</b> — R/WL. When set, this bit indicates that the Base and Limit fields in this register are valid and that writes and erases directed to addresses between them (inclusive) must be blocked by hardware. The base and limit fields are ignored when this bit is cleared.
30:29	Reserved
28:16	<b>Protected Range Limit:</b> — R/WL. This field corresponds to FLA address bits 24:12 and specifies the upper limit of the protected range. Address bits 11:0 are assumed to be FFFh for the limit comparison. Any address greater than the value programmed in this field is unaffected by this protected range.
15	<b>Read Protection Enable:</b> — R/WL. When set, this bit indicates that the Base and Limit fields in this register are valid and that read directed to addresses between them (inclusive) must be blocked by hardware. The base and limit fields are ignored when this bit is cleared.
14:13	Reserved
12:0	<b>Protected Range Base:</b> — R/WL. This field corresponds to FLA address bits 24:12 and specifies the lower base of the protected range. Address bits 11:0 are assumed to be 000h for the base comparison. Any address less than the value programmed in this field is unaffected by this protected range.

### 20.1.14 PR2—Protected Range 2 Register (SPI Memory Mapped Configuration Registers)

Memory Address: SPIBAR + 7Ch  
Default Value: 00000000h

Attribute: R/WL  
Size: 32 bits

**Note:** This register can not be written when the FLOCKDN bit is set to 1.

Bit	Description
31	<b>Write Protection Enable:</b> — R/WL. When set, this bit indicates that the Base and Limit fields in this register are valid and that writes and erases directed to addresses between them (inclusive) must be blocked by hardware. The base and limit fields are ignored when this bit is cleared.
30:29	Reserved
28:16	<b>Protected Range Limit:</b> — R/WL. This field corresponds to FLA address bits 24:12 and specifies the upper limit of the protected range. Address bits 11:0 are assumed to be FFFh for the limit comparison. Any address greater than the value programmed in this field is unaffected by this protected range.
15	<b>Read Protection Enable:</b> — R/WL. When set, this bit indicates that the Base and Limit fields in this register are valid and that read directed to addresses between them (inclusive) must be blocked by hardware. The base and limit fields are ignored when this bit is cleared.
14:13	Reserved
12:0	<b>Protected Range Base:</b> — R/WL. This field corresponds to FLA address bits 24:12 and specifies the lower base of the protected range. Address bits 11:0 are assumed to be 000h for the base comparison. Any address less than the value programmed in this field is unaffected by this protected range.



### 20.1.15 PR3—Protected Range 3 Register (SPI Memory Mapped Configuration Registers)

Memory Address: SPIBAR + 80h                      Attribute:                      R/WL  
Default Value: 00000000h                      Size:                      32 bits

**Note:** This register can not be written when the FLOCKDN bit is set to 1.

Bit	Description
31	<b>Write Protection Enable:</b> — R/WL. When set, this bit indicates that the Base and Limit fields in this register are valid and that writes and erases directed to addresses between them (inclusive) must be blocked by hardware. The base and limit fields are ignored when this bit is cleared.
30:29	Reserved
28:16	<b>Protected Range Limit:</b> — R/WL. This field corresponds to FLA address bits 24:12 and specifies the upper limit of the protected range. Address bits 11:0 are assumed to be FFFh for the limit comparison. Any address greater than the value programmed in this field is unaffected by this protected range.
15	<b>Read Protection Enable:</b> — R/WL. When set, this bit indicates that the Base and Limit fields in this register are valid and that read directed to addresses between them (inclusive) must be blocked by hardware. The base and limit fields are ignored when this bit is cleared.
14:13	Reserved
12:0	<b>Protected Range Base:</b> — R/WL. This field corresponds to FLA address bits 24:12 and specifies the lower base of the protected range. Address bits 11:0 are assumed to be 000h for the base comparison. Any address less than the value programmed in this field is unaffected by this protected range.

### 20.1.16 PR4—Protected Range 4 Register (SPI Memory Mapped Configuration Registers)

Memory Address: SPIBAR + 84h                      Attribute:                      R/WL  
Default Value: 00000000h                      Size:                      32 bits

**Note:** This register can not be written when the FLOCKDN bit is set to 1.

Bit	Description
31	<b>Write Protection Enable:</b> — R/WL. When set, this bit indicates that the Base and Limit fields in this register are valid and that writes and erases directed to addresses between them (inclusive) must be blocked by hardware. The base and limit fields are ignored when this bit is cleared.
30:29	Reserved
28:16	<b>Protected Range Limit:</b> — R/WL. This field corresponds to FLA address bits 24:12 and specifies the upper limit of the protected range. Address bits 11:0 are assumed to be FFFh for the limit comparison. Any address greater than the value programmed in this field is unaffected by this protected range.
15	<b>Read Protection Enable:</b> — R/WL. When set, this bit indicates that the Base and Limit fields in this register are valid and that read directed to addresses between them (inclusive) must be blocked by hardware. The base and limit fields are ignored when this bit is cleared.
14:13	Reserved
12:0	<b>Protected Range Base:</b> — R/WL. This field corresponds to FLA address bits 24:12 and specifies the lower base of the protected range. Address bits 11:0 are assumed to be 000h for the base comparison. Any address less than the value programmed in this field is unaffected by this protected range.



## 20.1.17 SSFS—Software Sequencing Flash Status Register (SPI Memory Mapped Configuration Registers)

Memory Address: SPIBAR + 90h  
Default Value: 00h

Attribute: RO, R/WC  
Size: 8 bits

**Note:** The Software Sequencing control and status registers are reserved if the hardware sequencing control and status registers are used.

Bit	Description
7:5	Reserved
4	<b>Access Error Log (AEL):</b> — RO. This bit reflects the value of the Hardware Sequencing Status AEL register.
3	<b>Flash Cycle Error (FCERR):</b> — R/WC. Hardware sets this bit to 1 when a programmed access is blocked from running on the SPI interface due to one of the protection policies or when any of the programmed cycle registers is written while a programmed access is already in progress. This bit remains asserted until cleared by software writing a 1 or hardware reset. Hardware reset is initiated by one of the following resets: <ul style="list-style-type: none"> <li>Global reset (when the Host and the ME partitions are both reset) - on both ME-enabled and non-ME systems.</li> <li>Host Partition reset (any time PLTRST# is asserted either from a cold or a warm reset) - only on ME enabled systems.</li> </ul>
2	<b>Cycle Done Status:</b> — R/WC. The ICH8 sets this bit to 1 when the SPI Cycle completes (i.e., SCIP bit is 0) after software sets the GO bit. This bit remains asserted until cleared by software writing a 1 or hardware reset. When this bit is set and the SPI SMI# Enable bit is set, an internal signal is asserted to the SMI# generation block. Software must make sure this bit is cleared prior to enabling the SPI SMI# assertion for a new programmed access. Hardware reset is initiated by one of the following resets: <ul style="list-style-type: none"> <li>Global reset (when the Host and the ME partitions are both reset) - on both ME-enabled and non-ME systems.</li> <li>Host Partition reset (any time PLTRST# is asserted either from a cold or a warm reset) - only on ME enabled systems.</li> </ul>
1	Reserved
0	<b>SPI Cycle In Progress (SCIP):</b> — RO. Hardware sets this bit when software sets the SPI Cycle Go bit in the Command register. This bit remains set until the cycle completes on the SPI interface. Hardware automatically sets and clears this bit so that software can determine when read data is valid and/or when it is safe to begin programming the next command. Software must only program the next command when this bit is 0.



## 20.1.18 SSFC—Software Sequencing Flash Control Register (SPI Memory Mapped Configuration Registers)

Memory Address: SPIBAR + 91h  
Default Value: 000000h

Attribute: R/W  
Size: 24 bits

Bit	Description
23:19	Reserved
18:16	<p><b>SPI Cycle Frequency (SCF):</b> — R/W. 000 = 20 MHz 001 = 33 MHz Software should program this register to set the frequency of the cycle that is to be run.</p>
15	<p><b>SPI SMI# Enable (SME):</b> — R/W. When set to 1, the SPI asserts an SMI# request whenever the Cycle Done Status bit is 1.</p>
14	<p><b>Data Cycle (DS):</b> — R/W. When set to 1, there is data that corresponds to this transaction. When 0, no data is delivered for this cycle, and the DBC and data fields themselves are don't cares</p>
13:8	<p><b>Data Byte Count (DBC):</b> — R/W. This field specifies the number of bytes to shift in or out during the data portion of the SPI cycle. The valid settings (in decimal) are any value from 0 to 63. The number of bytes transferred is the value of this field plus 1. Note that when this field is 00_0000b, then there is 1 byte to transfer and that 11_1111b means there are 64 bytes to transfer.</p>
7	Reserved
6:4	<p><b>Cycle Opcode Pointer (COP):</b> — R/W. This field selects one of the programmed opcodes in the Opcode Menu to be used as the SPI Command/Opcode. In the case of an Atomic Cycle Sequence, this determines the second command. — R/W.</p>
3	<p><b>Sequence Prefix Opcode Pointer (SPOP):</b> — R/W. This field selects one of the two programmed prefix opcodes for use when performing an Atomic Cycle Sequence. A value of 0 points to the opcode in the least significant byte of the Prefix Opcodes register. By making this programmable, the ICH8 supports flash devices that have different opcodes for enabling writes to the data space vs. status register.</p>
2	<p><b>Atomic Cycle Sequence (ACS):</b> — R/W. When set to 1 along with the SCGO assertion, the ICH8 will execute a sequence of commands on the SPI interface without allowing the LAN component to arbitrate and interleave cycles. The sequence is composed of:</p> <ul style="list-style-type: none"> <li>• Atomic Sequence Prefix Command (8-bit opcode only)</li> <li>• Primary Command specified below by software (can include address and data)</li> <li>• Polling the Flash Status Register (opcode 05h) until bit 0 becomes 0b.</li> </ul> <p>The SPI Cycle in Progress bit remains set and the Cycle Done Status bit remains unset until the Busy bit in the Flash Status Register returns 0.</p>
1	<p><b>SPI Cycle Go (SCGO):</b> — R/WS. This bit always returns 0 on reads. However, a write to this register with a '1' in this bit starts the SPI cycle defined by the other bits of this register. The "SPI Cycle in Progress" (SCIP) bit gets set by this action. Hardware must ignore writes to this bit while the Cycle In Progress bit is set. Hardware allows other bits in this register to be programmed for the same transaction when writing this bit to 1. This saves an additional memory write.</p>
0	Reserved



### 20.1.19 PREOP—Prefix Opcode Configuration Register (SPI Memory Mapped Configuration Registers)

Memory Address: SPIBAR + 94h                      Attribute:                      R/WL  
Default Value:    0000h                              Size:                              16 bits

Bit	Description
15:8	<b>Prefix Opcode 1</b> — R/W. Software programs an SPI opcode into this field that is permitted to run as the first command in an atomic cycle sequence.
7:0	<b>Prefix Opcode 0</b> — R/W. Software programs an SPI opcode into this field that is permitted to run as the first command in an atomic cycle sequence.

**NOTE:** This register is not writable when the Flash Configuration Lock-Down bit (SPIBAR + 04h:15) is set.

### 20.1.20 OPTYPE—Opcode Type Configuration Register (SPI Memory Mapped Configuration Registers)

Memory Address: SPIBAR + 96h                      Attribute:                      R/W  
Default Value:    0000h                              Size:                              16 bits

Entries in this register correspond to the entries in the Opcode Menu Configuration register.

**Note:** The definition below only provides write protection for opcodes that have addresses associated with them. Therefore, any erase or write opcodes that do not use an address should be avoided (for example, “Chip Erase” and “Auto-Address Increment Byte Program”)

Bit	Description
15:14	<b>Opcode Type 7</b> — R/W. See the description for bits 1:0
13:12	<b>Opcode Type 6</b> — R/W. See the description for bits 1:0
11:10	<b>Opcode Type 5</b> — R/W. See the description for bits 1:0
9:8	<b>Opcode Type 4</b> — R/W. See the description for bits 1:0
7:6	<b>Opcode Type 3</b> — R/W. See the description for bits 1:0
5:4	<b>Opcode Type 2</b> — R/W. See the description for bits 1:0
3:2	<b>Opcode Type 1</b> — R/W. See the description for bits 1:0
1:0	<p><b>Opcode Type 0</b> — R/W. This field specifies information about the corresponding Opcode 0. This information allows the hardware to 1) know whether to use the address field and 2) provide BIOS and Shared Flash protection capabilities. The encoding of the two bits is:</p> <p>00 = No address associated with this Opcode; Read cycle type 01 = No address associated with this Opcode; Write cycle type 10 = Address required; Read cycle type 11 = Address required; Write cycle type</p>

**NOTE:** This register is not writable when the SPI Configuration Lock-Down bit (SPIBAR + 00h:15) is set.



## 20.1.21 OPMENU—Opcode Menu Configuration Register (SPI Memory Mapped Configuration Registers)

Memory Address: SPIBAR + 98h                      Attribute:                      R/W  
Default Value: 0000000000000000h              Size:                              64 bits

Eight entries are available in this register to give BIOS a sufficient set of commands for communicating with the flash device, while also restricting what malicious software can do. This keeps the hardware flexible enough to operate with a wide variety of SPI devices.

**Note:** It is recommended that BIOS avoid programming Write Enable opcodes in this menu. Malicious software could then perform writes and erases to the SPI flash without using the atomic cycle mechanism. This could cause functional failures in a shared flash environment. Write Enable opcodes should only be programmed in the Prefix Opcodes.

Bit	Description
63:56	<b>Allowable Opcode 7</b> — R/W. See the description for bits 7:0
55:48	<b>Allowable Opcode 6</b> — R/W. See the description for bits 7:0
47:40	<b>Allowable Opcode 5</b> — R/W. See the description for bits 7:0
39:32	<b>Allowable Opcode 4</b> — R/W. See the description for bits 7:0
31:24	<b>Allowable Opcode 3</b> — R/W. See the description for bits 7:0
23:16	<b>Allowable Opcode 2</b> — R/W. See the description for bits 7:0
15:8	<b>Allowable Opcode 1</b> — R/W. See the description for bits 7:0
7:0	<b>Allowable Opcode 0</b> — R/W. Software programs an SPI opcode into this field for use when initiating SPI commands through the Control Register.

This register is not writable when the SPI Configuration Lock-Down bit (SPIBAR + 00h:15) is set.





### 20.1.22 FDOC—Flash Descriptor Observability Control Register (SPI Memory Mapped Configuration Registers)

Memory Address: SPIBAR + B0h                      Attribute:              R/W  
 Default Value: 00000000h                      Size:                      32 bits

**Note:** This register that can be used to observe the contents of the Flash Descriptor that is stored in the ICH8 Flash Controller.

Bit	Description
31:15	Reserved
14:12	<b>Flash Descriptor Section Select (FDSS):</b> — R/W. This field selects which section within the loaded Flash Descriptor to observe. 000 = Flash Signature and Descriptor Map 001 = Component 010 = Region 011 = Master 100 = ICH8 Soft Straps 111 = Reserved
11:2	<b>Flash Descriptor Section Index (FDSI):</b> — R/W. This field selects the DW offset within the Flash Descriptor Section to observe.
1:0	Reserved

### 20.1.23 FDOD—Flash Descriptor Observability Data Register (SPI Memory Mapped Configuration Registers)

Memory Address: SPIBAR + B4h                      Attribute:              RO  
 Default Value: 00000000h                      Size:                      32 bits

**Note:** This register that can be used to observe the contents of the Flash Descriptor that is stored in the ICH8 Flash Controller.

Bit	Description
31:0	<b>Flash Descriptor Section Data (FDSD):</b> — RO. This field returns the DW of data to observe as selected in the Flash Descriptor Observability Control.



### 20.1.24 VSCC—Vendor Specific Component Capabilities Register (SPI Memory Mapped Configuration Registers)

Memory Address: SPIBAR + C1h                      Attribute:                      RO, R/WL  
 Default Value: 00000000h                      Size:                      32 bits

Bit	Description
23	<p><b>Vendor Component Lock (VCL):</b> — R/W:</p> <p>0 = The lock bit is not set            1 = The Vendor Component Lock bit is set.            This register locks itself when set.</p>
22:16	Reserved
15:8	<p><b>Erase Opcode (EO)</b> — R/W: This register is programmed with the Flash erase instruction opcode required by the vendor’s Flash component.</p> <p><b>NOTE:</b> If there is more than one component, both components must use the same Erase Opcode.            This register is locked by the Vendor Component Lock (VCL) bit.</p>
7:4	Reserved
3	<p><b>Write Status Required (WSR)</b> — R/W</p> <p>0 = No Enable write to the status register (50h) opcode is required to write to the SPI flash Status Register(s) prior to write or erase to remove SPI flash protection.            1 = Enable write to the status register (50h) opcode is required to write to the SPI flash Status Register(s) prior to write or erase to remove SPI flash protection.</p> <p><b>NOTE:</b> If there is more than one component, both components must use the same Write Status Required setting. SPI Protection is removed by writing 00h to SPI flash Status Register(s).</p>
2	<p><b>Write Granularity (WG)</b> — R/W:</p> <p>0 = 1 Byte            1 = 64 Byte            This register is locked by the Vendor Component Lock (VCL) bit.</p> <p><b>NOTE:</b> If more than one Flash component exists, this field must be set to the lowest common write granularity of the different Flash components.</p>
1:0	<p><b>Block/Sector Erase Size (BSES)</b>— R/W: This field identifies the erasable sector size for all Flash components.</p> <p>00 = 256 Byte            01 = 4 KB            10 =Reserved for future use            11 = 64 KB            This register is locked by the Vendor Component Lock (VCL) bit.</p> <p><b>NOTE:</b> If supporting more than one Flash component, all flash components must have identical Block/Sector erase sizes.            This register is locked by the Vendor Component Lock (VCL) bit.            Hardware takes no action based on the value of this register. The contents of this register are to be used only by software and can be read in the HSFSTS.BERASE register in both the BIOS and the GbE program registers.</p>



## 20.2 Flash Descriptor Registers

The following sections describe the data structure of the Flash Descriptor on the SPI device. These are not registers within the ICH8.

### 20.2.1 Flash Descriptor Content

#### 20.2.1.1 FLVALSIG—Flash Valid Signature Register (Flash Descriptor Memory Mapped Configuration Registers)

Memory Address: FDBAR + 000h                      Size:                      32 bits

Bits	Description
31:0h	<b>Flash Valid Signature:</b> This field identifies the Flash Descriptor sector as valid. If the contents at this location contain OFF0A55Ah, then the Flash Descriptor is considered valid and it will operate in Descriptor Mode, else it will operate in Non-Descriptor Mode.

#### 20.2.1.2 FLMAPO—Flash Map 0 Register (Flash Descriptor Memory Mapped Configuration Registers)

Memory Address: FDBAR + 004h                      Size:                      32 bits

Bits	Description
31:27	Reserved
26:24	<b>Number Of Regions (NR):</b> This field identifies the total number of Flash Regions. This number is 0's based, so a setting of all 0s indicates that the only Flash region is region 0, the Flash Descriptor region.
23:16	<b>Flash Region Base Address (FRBA):</b> This identifies address bits [11:4] for the Region portion of the Flash Descriptor. Bits [24:12] and bits [3:0] are 0. For validation purposes, the recommended FRBA is: 04h
15:10	Reserved
9:8	<b>Number Of Components (NC):</b> This field identifies the total number of Flash Components. Each supported Flash Component requires a separate chip select 00 = 1 Component 01 = 2 Components All other settings = Reserved
7:0	<b>Flash Component Base Address (FCBA):</b> This identifies address bits [11:4] for the component portion of the Flash Descriptor. Bits [24:12] and bits [3:0] are 0. For validation purposes, the recommended FCBA is: 01h.



### 20.2.1.3 FLMAP1—Flash Map 1 Register (Flash Descriptor Memory Mapped Configuration Registers)

Memory Address: FDBAR + 008h                      Size:                      32 bits

Bits	Description
31:24	<b>ICH8 Strap Length (ISL):</b> This field identifies the 1's based number of DWords of ICH8 Straps to be read, up to 255 DWs (1 KB) maximum. A setting of all 0s indicates there are no ICH8 DW straps.
23:16	<b>Flash ICH8 Strap Base Address (FISBA):</b> This field identifies address bits [11:4] for the ICH8 Strap portion of the Flash Descriptor. Bits [24:12] and bits [3:0] are 0. For validation purposes, the recommended FISBA is: 10h
15:11	Reserved
10:8	<b>Number Of Masters (NM):</b> This field identifies the total number of Flash Regions. This number is 0's based.
7:0	<b>Flash Master Base Address (FMBA):</b> This identifies address bits [11:4] for the Master portion of the Flash Descriptor. Bits [24:12] and bits [3:0] are 0. For validation purposes, the recommended FMBA is: 06h

### 20.2.1.4 FLMAP2—Flash Map 2 Register (Flash Descriptor Memory Mapped Configuration Registers)

Memory Address: FDBAR + 00Ch                      Size:                      32 bits

Bits	Description
31:16	Reserved
15:8	<b>MCH Strap Length (MSL):</b> This field identifies the 1s based number of DWords of MCH Straps to be read, up to 255 DWs (1 KB) maximum. A setting of all 0s indicates there are no MCH DW straps.
7:0	<b>Flash MCH Strap Base Address (FMSBA):</b> This identifies address bits [11:4] for the MCH Strap portion of the Flash Descriptor. Bits [24:12] and bits [3:0] are 0. For validation purposes, the recommended FMSBA is: 20h



## 20.2.2 Flash Descriptor Component Section

The following section of the Flash Descriptor is used to identify the different Flash Components and their capabilities.

### 20.2.2.1 FLCOMP—Flash Components Register (Flash Descriptor Memory Mapped Configuration Registers)

Memory Address: FCBA + 000h                      Size:                      32 bits

Bits	Description
31:30	Reserved
29:27	<p><b>Read ID and Read Status Clock Frequency:</b>            000 = 20 MHz            001 = 33 MHz            All other Settings: Reserved</p> <p><b>NOTE:</b> If more than one Flash component exists, this field must be set to the lowest common frequency of the different Flash components.</p>
26:24	<p><b>Write and Erase Clock Frequency:</b>            000 = 20 MHz            001 = 33 MHz            All other Settings: Reserved</p> <p><b>NOTE:</b> If more than one Flash component exists, this field must be set to the lowest common frequency of the different Flash components.</p>
23:21	<p><b>Fast Read Clock Frequency:</b> This field identifies the frequency that can be used with the Fast Read instruction. This field is undefined if the Fast Read Support field is 0.            000 = 20 MHz            001 = 33 MHz            All other Settings = Reserved</p> <p><b>NOTE:</b> If more than one Flash component exists, this field must be set to the lowest common frequency of the different Flash components.</p>
20	<p><b>Fast Read Support:</b>            0 = Fast Read is not Supported            1 =Fast Read is supported</p> <p>If the Fast Read Support bit is a '1' and a device issues a Direct Read or issues a read command from the Hardware Sequencer and the length is greater than 4 bytes, then the SPI Flash instruction should be "Fast Read". If the Fast Read Support is a '0' or the length is 1-4 bytes, then the SPI Flash instruction should be "Read".</p> <p>Reads to the Flash Descriptor always use the Read command independent of the setting of this bit.</p> <p><b>NOTE:</b> If more than one Flash component exists, this field can only be set to '1' if both components support Fast Read.</p>
19:17	<p><b>Read Clock Frequency:</b>            000 = 20 MHz            All other Settings = Reserved</p> <p><b>NOTE:</b> If more than one Flash component exists, this field must be set to the lowest common frequency of the different Flash components.</p>



Bits	Description
16:06	Reserved
5:3	<p><b>Component 2 Density:</b> This field identifies the size of the 2nd Flash component. If there is not 2nd Flash component, the contents of this field are undefined.</p> <p>Valid Bit Settings:</p> <p>000 = 512 KB            001 = 1 MB            010 = 2 MB            011 = 4 MB            100 = 8 MB            101 = 16 MB            111 = Reserved</p>
2:0	<p><b>Component 1 Density:</b> This field identifies the size of the 1st or only Flash component.</p> <p>Valid Bit Settings:</p> <p>000 = 512 KB            001 = 1 MB            010 = 2 MB            011 = 4 MB            100 = 8 MB            101 = 16 MB            111 = Reserved</p> <p>This field is defaulted to "101b" (16MB) after reset. In non-descriptor mode, only one flash component is supported and all accesses to flash will be to this component.</p>

**20.2.2.2 FLILL—Flash Invalid Instructions Register (Flash Descriptor Memory Mapped Configuration Registers)**

Memory Address: FCBA + 004h                      Size:                      32 bits

Bits	Description
31:24	Invalid Instruction 3: See definition of Invalid Instruction 0
23:16	Invalid Instruction 2: See definition of Invalid Instruction 0
15:8	Invalid Instruction 1: See definition of Invalid Instruction 0
7:0	Invalid Instruction 0: Op-code for an invalid instruction in the that the Flash Controller should protect against instructions such as Chip Erase. This byte should be set to 0 if there are no invalid instructions to protect against for this field. Op-codes programmed in the Software Sequencing Opcode Menu Configuration and Prefix-Opcode Configuration are not allowed to use any of the Invalid Instructions listed in this register.



### 20.2.3 Flash Descriptor Region Section

The following section of the Flash Descriptor is used to identify the different Flash Regions

Flash Regions:

- If a particular region is not using SPI Flash, the particular region should be disabled by setting the Region Base to all 1's, and the Region Limit to all 0's (base is higher than the limit)
- For each region except FLREG0, the Flash Controller must have a default Region Base of FFFh and the Region Limit to 000h within the Flash Controller in case the Number of Regions specifies that a region is not used.

#### 20.2.3.1 FLREG0—Flash Region 0 (Flash Descriptor) Register (Flash Descriptor Memory Mapped Configuration Registers)

Memory Address: FRBA + 000h                      Size:                      32 bits

Bits	Description
31:29	Reserved
28:16	<b>Region Limit:</b> This field specifies address bits 24:12 for the Region Limit.
15:13	Reserved
12:0	<b>Region Base:</b> This specifies address bits 24:12 for the Region Base.

#### 20.2.3.2 FLREG1—Flash Region 1 (BIOS) Register (Flash Descriptor Memory Mapped Configuration Registers)

Memory Address: FRBA + 004h                      Size:                      32 bits

Bits	Description
31:29	Reserved
28:16	<b>Region Limit:</b> This field specifies address bits 24:12 for the Region Limit.
15:13	Reserved
12:0	<b>Region Base:</b> This specifies address bits 24:12 for the Region Base. <b>NOTE:</b> If the BIOS region is not used, the Region Base must be programmed to 1FFFh and the Region Limit to 0000h to disable the region.



### 20.2.3.3 FLREG2—Flash Region 2 (ME) Register (Flash Descriptor Memory Mapped Configuration Registers)

Memory Address: FRBA + 008h                      Size:                      32 bits

Bits	Description
31:29	Reserved
28:16	<b>Region Limit:</b> This field specifies address bits 24:12 for the Region Limit.
15:13	Reserved
12:0	<b>Region Base:</b> This field specifies address bits 24:12 for the Region Base. <b>NOTE:</b> If the BIOS region is not used, the Region Base must be programmed to 1FFFh and the Region Limit to 0000h to disable the region.

### 20.2.3.4 FLREG3—Flash Region 3 (GbE) Register (Flash Descriptor Memory Mapped Configuration Registers)

Memory Address: FRBA + 00Ch                      Size:                      32 bits

Bits	Description
31:29	Reserved
28:16	<b>Region Limit:</b> This field specifies address bits 24:12 for the Region Limit. <b>NOTE:</b> The maximum Region Limit is 128KB above the region base.
15:13	Reserved
12:0	<b>Region Base:</b> This field specifies address bits 24:12 for the Region Base. <b>NOTE:</b> If the BIOS region is not used, the Region Base must be programmed to 1FFFh and the Region Limit to 0000h to disable the region.





## 20.2.4 Flash Descriptor Master Section

### 20.2.4.1 FLMSTR1—Flash Master 1 (Host Processor/ BIOS)

Memory Address: FMBA + 000h                      Size:                      32 bits

Bits	Description
31:28	Reserved, must be zero
27	<b>GbE Master Region Write Access:</b> If the bit is set, this master can erase and write that particular region through register accesses.
26	<b>ME Master Region Write Access:</b> If the bit is set, this master can erase and write that particular region through register accesses.
25	<b>Host CPU/BIOS Master Region Write Access:</b> If the bit is set, this master can erase and write that particular region through register accesses. Bit 25 is a don't care as the primary master always has read/write permissions to it's primary region
24	<b>Flash Descriptor Master Region Write Access:</b> If the bit is set, this master can erase and write that particular region through register accesses.
23:20	Reserved, must be zero
19	<b>GbE Master Region Read Access:</b> If the bit is set, this master can read that particular region through register accesses.
18	<b>ME Master Region Read Access:</b> If the bit is set, this master can read that particular region through register accesses.
17	<b>Host CPU/BIOS Master Region Read Access:</b> If the bit is set, this master can read that particular region through register accesses. Bit 17 is a don't care as the primary master always has read/write permissions to it's primary region
16	<b>Flash Descriptor Master Region Read Access:</b> If the bit is set, this master can read that particular region through register accesses.
15:0	<b>Requester ID:</b> This is the Requester ID of the Host CPU. This must be set to 0000h.

### 20.2.4.2 FLMSTR2—Flash Master 2 (ME)

Memory Address: FMBA + 004h                      Size:                      32 bits

Bits	Description
31:28	Reserved, must be zero
27	<b>GbE Master Region Write Access:</b> If the bit is set, this master can erase and write that particular region through register accesses.
26	<b>ME Master Region Write Access:</b> If the bit is set, this master can erase and write that particular region through register accesses. Bit 26 is a don't care as the primary master always has read/write permissions to it's primary region
25	<b>Host CPU/BIOS Master Region Write Access:</b> If the bit is set, this master can erase and write that particular region through register accesses.
24	<b>Flash Descriptor Master Region Write Access:</b> If the bit is set, this master can erase and write that particular region through register accesses.
23:20	Reserved, must be zero



Bits	Description
19	<b>GbE Master Region Read Access:</b> If the bit is set, this master can read that particular region through register accesses.
18	<b>ME Master Region Read Access:</b> If the bit is set, this master can read that particular region through register accesses. Bit 18 is a don't care as the primary master always has read/write permissions to it's primary region
17	<b>Host CPU/BIOS Master Region Read Access:</b> If the bit is set, this master can read that particular region through register accesses.
16	<b>Flash Descriptor Master Region Read Access:</b> If the bit is set, this master can read that particular region through register accesses.
15:0	<b>Requester ID:</b> This is the Requester ID of the ME. This must be set to 0000h.

### 20.2.4.3 FLMSTR3—Flash Master 3 (GbE)

Memory Address: FMBA + 008h

Size:

32 bits

Bits	Description
31:28	Reserved, must be zero
27	<b>GbE Master Region Write Access:</b> If the bit is set, this master can erase and write that particular region through register accesses. Bit 27 is a don't care as the primary master always has read/write permissions to it's primary region
26	<b>ME Master Region Write Access:</b> If the bit is set, this master can erase and write that particular region through register accesses.
25	<b>Host CPU/BIOS Master Region Write Access:</b> If the bit is set, this master can erase and write that particular region through register accesses.
24	<b>Flash Descriptor Master Region Write Access:</b> If the bit is set, this master can erase and write that particular region through register accesses.
23:20	Reserved, must be zero
19	<b>GbE Master Region Read Access:</b> If the bit is set, this master can read that particular region through register accesses. Bit 19 is a don't care as the primary master always has read/write permissions to it's primary region
18	<b>ME Master Region Read Access:</b> If the bit is set, this master can read that particular region through register accesses.
17	<b>Host CPU/BIOS Master Region Read Access:</b> If the bit is set, this master can read that particular region through register accesses.
16	<b>Flash Descriptor Master Region Read Access:</b> If the bit is set, this master can read that particular region through register accesses.
15:0	<b>Requester ID:</b> This is the Requester ID of the GbE. This must be set to 0218h.



## 20.2.5 Flash Descriptor Strap

The following section of the Flash Descriptor is used to store strapping information.

The default value represents the internal strap signal value that is used if there is no valid SPI Flash.

### 20.2.5.1 STRP0—Strap 0 Register (Flash Descriptor Memory Mapped Configuration Registers)

Memory Address: FISBA + 000h

Size:

32 bits

Bits	Default	Description
31:25	0000000b	<b>ME SMBus Addr[6:0] (ASD2):</b> This field sets the 7-bit address for the Intel AMT SMBus Controller 2.
24	0	Reserved
23	1	<b>ME SMBus 2 Select (MESM2SEL):</b> 0 = Management Engine SMBus Controller 2 is connected to the SMBus pins 1 = Management Engine SMBus Controller 2 is connected to the SMLink pins
22	0	<b>SPI CS1# or LAN PHY Power Control (SPICS1_LANPHYPC_SEL)</b> 0 = SPI_CS1# is used for SPI Chip Select 1 = SPI_CS1# is used for LAN PHY Power Control Function <b>NOTE:</b> When configured as LAN PHY Power Control Function Bit 21=0 and Bit 20=1 of the Strap 0 register is an invalid configuration. The LAN PHY Power Control Function configures the ICH8 signal used as an output.
21:20	00b	<b>GPIO12 Select (GPIO12_SEL)</b> 00 = GPIO12 01 = LAN PHY Power Control Function (Native Output) 11 = GLAN_DOCK# (Native Input) 10 = Invalid Configuration  <b>NOTE:</b> When configured for LAN PHY Power Control Function, Bit 22 of the Strap 0 register must be set to 0. The LAN PHY Power Control Function configures the ICH8 signal used as an output.
19	0	<b>Integrated GbE or PCI Express Select (GLAN_PCIE_SEL):</b> 0 = PCIe Port 6 is used for PCI Express 1 = PCIe Port 6 is used for integrated GLAN  <b>NOTE:</b> If the Gigabit Platform LAN Connected Device is not used, this bit may be set to 0.
18:16	0	Reserved
15	0	<b>BMC Mode (BMCMODE):</b> This field is only valid when TCOMODE bit 7 is set to 1. 0 = Not BMC mode. Supports Intel® Active Management Technology or ASF. Intel AMT SMBus Controller 1 is connected to SMBus. 1 = BMC Mode. Intel AMT SMBus Controller 1 is connected to SMLink.
14:8	0000000b	<b>ME SMBus Addr[6:0] (ASD):</b> This field sets the 7-bit address for the Intel AMT SMBus Controller 1.



Bits	Default	Description
7	0	<p><b>TCO Mode (TCOMODE):</b> This field configures the location of the TCO slave and also enables/disables the Intel AMT SMBus Controller 1.</p> <p>0 = Legacy/Compatible Mode: In this mode the TCO slave is Multiplexed onto the SMLink pins. The Intel AMT SMBus Controller 1 is disabled.</p> <p>1 = Advanced TCO Mode: In this mode the TCO slave is Multiplexed onto the SMBus pins. The Intel AMT SMBus Controller 1 is enabled. The Intel AMT SMBus Controller 1 configuration is set by BMCMODE bit 15.</p> <p>The value of this strap is reflected in bit 1 of the SMBus Auxiliary Status (<a href="#">Section 16.2.11: AUX_STS – Auxiliary Status Register (SMBUS: D31:F3: SMBASE + 0Ch, bit 1)</a>).</p>
6:1	0	Reserved
0	1	<p><b>ME Disable (ME_DISABLE):</b></p> <p>0 = ME is enabled 1 = ME is disabled</p> <p><b>NOTE:</b> This bit and bit 0 of <a href="#">Section 20.2.5.2 (FMSBA+000h)</a> must be set to 1 to disable Management Engine on the platform.</p>

**NOTES:** ICH8M supports 3 TCO modes.

1. Legacy TCO mode: Selection through STRAP0 BIT 7
2. Advanced TCO pro-active mode: Selection through STRAP0 BIT 7 and BIT15=0
3. Advanced TCO BMC mode: Selection through STRAP0 BIT 7 and BIT15=1

### 20.2.5.2 STRP1—Strap 1 Register (Flash Descriptor Memory Mapped Configuration Registers)

Memory Address: FMSBA + 000h                      Size:                      32 bits

Bits	Default	Description
31:1	0	Reserved
0	1	<p><b>ME Disable B(MDB):</b></p> <p>0 = ME is enabled 1 = ME is disabled</p> <p><b>NOTE:</b> This bit and bit 0 of <a href="#">Section 20.2.5.1 (FMSBA+000h)</a> must be set to 1 in order to disable ME on the platform.</p>



### 20.2.5.3 FLUMAP1—Flash Upper Map 1

Memory Address: EFCh Attribute:  
 Default Value: 00FFh Size: 32 bits

**Note:** if VTL and VTBA values are FF then firmware will assume there are no entries in VSCC table.

Bits	Default	Description
31:16	0	Reserved
15:8	1	<b>VSCC Table Length (VTL):</b> Identifies the 1's based number of DWORDS contained in the VSCC Table. Each SPI Component entry in the table is 2 DWORDS long.
7:0	1	<b>VSCC Table Base Address (VTBA):</b> This identifies address bits [11:4] for the VSCC Table portion of the Flash Descriptor. Bits [24:12] and bits [3:0] are 0.

### 20.2.5.4 JID0—JEDEC-ID 0 Register

Memory Address: VTBA + 000h Attribute:  
 Default Value: Size: 32 bits

Bits	Description
31:24	Reserved
23:16	<b>SPI Component Device ID 1:</b> This identifies the second byte of the Device ID of the SPI Flash Component. This is the third byte returned by the Read JEDEC-ID command (opcode 9Fh).
15:8	<b>SPI Component Device ID 0:</b> This identifies the first byte of the Device ID of the SPI Flash Component. This is the second byte returned by the Read JEDEC-ID command (opcode 9Fh).
7:0	<b>SPI Component Vendor ID:</b> This identifies the one byte Vendor ID of the SPI Flash Component. This is the first byte returned by the Read JEDEC-ID command (opcode 9Fh).

### 20.2.5.5 VSCC0—Vendor Specific Component Capabilities 0

Memory Address: VTBA + 004h Attribute:  
 Default Value: Size: 32 bits

Bits	Description
31:17	Reserved
17	<p><b>Write Enable on Write to Status (WEWS):</b>            0 = No Write Enable (06h) command is required to write to the Status register            1 = Write Enable (06h) is required to the Write Status Register prior to write and erase to remove any protection.</p> <p><b>NOTE:</b> If there is more than one component, both components must use the same Write Enable on to write to the Status Register on the SPI flash.</p>



Bits	Description
15:8	<b>Erase Opcode (EO):</b> This register is programmed with the Flash erase instruction opcode required by this vendors Flash component. Note: If there is more than one component, both components must use the same Erase Opcode.
7:4	Reserved
3	<b>Write Status Required (WSR):</b> 0 = No Enable write to the status register (50h) opcode is required to write to the SPI flash Status Register(s) prior to write or erase to remove SPI flash protection. 1 = Enable write to the status register (50h) opcode is required to write to the SPI flash Status Register(s) prior to write or erase to remove SPI flash protection.  <b>NOTE:</b> If there is more than one component, both components must use the same Write Status Required setting. SPI Protection is removed by writing 00h to SPI flash Status Register(s).
2	<b>Write Granularity (WG):</b> 0 = 1 Byte 1 = 64 Byte All Other Settings: Reserved  <b>NOTE:</b> If more than one Flash component exists, this field must be set to the lowest common write granularity of the different Flash components.
1:0	<b>Block/Sector Erase Size (BES):</b> This field identifies the erasable sector size for all Flash components. Valid Bit Settings: 00 = 256 Byte 01 = 4 KB 10 = Reserved for future use 11 = 64KB  <b>NOTE:</b> If supporting more than one Flash component, all flash components must have identical Block/ Sector erase sizes.

### 20.2.5.6 JID0—JEDEC-ID n Register

Memory Address: VTBA + (n\*8)h                      Attribute:  
 Default Value:    Size:    32 bits

Bits	Description
31:24	Reserved
23:16	<b>SPI Component Device ID 1:</b> This identifies the second byte of the Device ID of the SPI Flash Component. This is the third byte returned by the Read JEDEC-ID command (opcode 9Fh).
15:8	<b>SPI Component Device ID 0:</b> This identifies the first byte of the Device ID of the SPI Flash Component. This is the second byte returned by the Read JEDEC-ID command (opcode 9Fh).
7:0	<b>SPI Component Vendor ID:</b> This identifies the one byte Vendor ID of the SPI Flash Component. This is the first byte returned by the Read JEDEC-ID command (opcode 9Fh).



### 20.2.5.7 VSCC0n—Vendor Specific Component Capabilities n

Memory Address: VTBA + 004h + (n\*8)      Attribute:  
 Default Value:                                      Size:                                      32 bits

**Note:** “n” is an integer denoting the number of table entries.

Bits	Description
31:17	Reserved
16	<p><b>Write Enable on Write Status (WEWS):</b>            0 = No Write Enable (06h) opcode is required to write to the SPI Flash Status register(s).            1 = Write Enable (06h) opcode is required to write to the SPI Flash Status Register(s) prior to write and erase to remove SPI flash protection.</p> <p><b>NOTE:</b> If there is more than one component, both components must use the same Write Enable on to write to the Status Register on the SPI flash.</p>
15:8	<p><b>Erase Opcode (EO):</b> This register is programmed with the Flash erase instruction opcode required by this vendors Flash component.</p> <p><b>NOTE:</b> If there is more than one component, both components must use the same Erase Opcode.</p>
7:4	Reserved
3	<p><b>Write Status Required (WSR):</b>            0 = No requirement to write to the Write Status Register prior to a write            1 = Enable status register write (50h) command is required to write to the Write Status register</p> <p><b>NOTE:</b> If there is more than one component, both components must use the same Write Status Required. Uses 50h to enable a write to the Write Status Register</p>
2	<p><b>Write Granularity (WG):</b>            0 = 1 Byte            1 = 64 Byte            All Other Settings = Reserved</p> <p><b>NOTE:</b> If more than one Flash component exists, this field must be set to the lowest common write granularity of the different Flash components.</p>
1:0	<p><b>Block/Sector Erase Size (BES):</b> This field identifies the erasable sector size for all Flash components.            Valid Bit Settings:            00 = 256 Byte            01 = 4 KB            10 = Reserved for future use            11 = 64 KB</p> <p><b>NOTE:</b> If supporting more than one Flash component, all flash components must have identical Block/ Sector erase sizes.</p>



### 20.2.5.8 OEM Section

Memory Address: F00h  
 Default Value:

Attribute:  
 Size: 256 Bytes

256 Bytes are reserved at the top of the Flash Descriptor for use by OEM. The information stored by the OEM can only be written during the manufacturing process as the Flash Descriptor read/write permissions must be set to Read Only when the computer leaves the manufacturing floor. The ICH Flash controller does not read this information. FFh is suggested to reduce programming time.

## 20.3 GbE SPI Flash Program Registers

The GbE Flash registers are memory-mapped with a base address GLBAR found in the GbE LAN register chapter Device 25: Function 0: Offset 18h. (MBCRC Register). The individual registers are then accessible at GLBAR + Offset as indicated in [Table 144](#).

These memory-mapped registers must be accessed in byte, word, or DWord quantities.

**Table 144. Gigabit LAN SPI Flash Program Register Address Map (GbE LAN Memory Mapped Configuration Registers)**

GLBAR + Offset	Mnemonic	Register Name	Default	Access
00h–03h	GLFPR	Gigabit LAN Flash Primary Region	00000000h	RO
04h–05h	HSFS	Hardware Sequencing Flash Status	0000h	RO, R/W, R/WL
06h–07h	HSFC	Hardware Sequencing Flash Control	0000h	R/W, R/WS
08h–0Bh	FADDR	Flash Address	00000000h	R/W
0Ch–0Fh	—	Reserved	00000000h	—
10h–13h	FDATA0	Flash Data 0	00000000h	R/W
14h–4Fh	—d	Reserved	00000000h	—
50h–53h	FRACC	Flash Region Access Permissions	00000000h	RO, R/WL
54h–57h	FREG0	Flash Region 0	00000000h	RO
58h–5Bh	FREG1	Flash Region 1	00000000h	RO
5Ch–5F	FREG2	Flash Region 2	00000000h	RO
60h–63h	FREG3	Flash Region 3	00000000h	RO
64h–73h	—	Reserved for Future Flash Regions	—	—
74h–77h	FPR0	Flash Protected Range 0	00000000h	R/WL
78h–7Bh	FPR1	Flash Protected Range 1	00000000h	R/WL
7Ch–8Fh	Reserved	Reserved		
90h	SSFS	Software Sequencing Flash Status	0000h	RO, R/WC
91h–93h	SSFC	Software Sequencing Flash Control	0000h	R/W
94h–95h	PREOP	Prefix Opcode Configuration	0000h	R/WL
96h–97h	OPTYPE	Opcode Type Configuration	0000h	R/W
98h–9Fh	OPMENU	Opcode Menu Configuration	00000000h	R/W
A0h–DFh	—	Reserved	—	—





### 20.3.1 GLFPR—Gigabit LAN Flash Primary Region Register (GbE LAN Memory Mapped Configuration Registers)

Memory Address: GLBAR + 00h  
Default Value: 00000000h

Attribute: RO  
Size: 32 bits

Bit	Description
31:29	Reserved
28:16	<b>GbE Flash Primary Region Limit (PRL):</b> — RO. This field specifies address bits 24:12 for the Primary Region Limit. The value in this register loaded from the contents in the Flash Descriptor.FLREG3.Region Limit
15:13	Reserved
12:0	<b>GbE Flash Primary Region Base (PRB)</b> — RO. This field specifies address bits 24:12 for the Primary Region Base The value in this register is loaded from the contents in the Flash Descriptor.FLREG3.Region Base



### 20.3.2 HSFS—Hardware Sequencing Flash Status Register (GbE LAN Memory Mapped Configuration Registers)

Memory Address: GLBAR + 04h  
Default Value: 0000h

Attribute: RO, R/WC, R/WL  
Size: 16 bits

Bit	Description
15	<p><b>Flash Configuration Lock-Down (FLOCKDN)</b>— R/W/L. When set to 1, those Flash Program Registers that are locked down by this FLOCKDN bit cannot be written. Once set to 1, this bit can only be cleared by a hardware reset.</p> <p>Hardware reset is initiated by one of the following resets:</p> <ul style="list-style-type: none"> <li>Global reset (when the Host and the ME partitions are both reset) - on both ME-enabled and non-ME systems.</li> <li>Host Partition reset (any time PLTRST# is asserted either from a cold or a warm reset) - only on ME enabled systems.</li> </ul>
14	<p><b>Flash Descriptor Valid (FDV)</b>— RO. This bit is set to a 1 if the Flash Controller read the correct Flash Descriptor Signature.</p> <p>If the Flash Descriptor Valid bit is not 1, software cannot use the Hardware Sequencing registers, but must use the software sequencing registers. Any attempt to use the Hardware Sequencing registers will result in the FCERR bit being set.</p>
13	<p><b>Flash Descriptor Override Pin Strap Status (FDOPSS)</b>— RO. This bit reflects the value the Flash Descriptor Override Pin-Strap.</p> <p>1 = No override 0 = The Flash Descriptor Override strap is set</p>
12:6	Reserved
5	<p><b>SPI Cycle In Progress (SCIP)</b>— RO. Hardware sets this bit when software sets the Flash Cycle Go (FGO) bit in the Hardware Sequencing Flash Control register. This bit remains set until the cycle completes on the SPI interface. Hardware automatically sets and clears this bit so that software can determine when read data is valid and/or when it is safe to begin programming the next command. Software must only program the next command when this bit is 0.</p>
4:3	<p><b>Block/Sector Erase Size (BERASE)</b> — RO. This field identifies the erasable sector size for all Flash components.</p> <p>Valid Bit Settings:</p> <p>00 = 256 Byte 01 = 4 KB 10 = Reserved for future use 11 = 64 KB</p>
2	<p><b>Access Error Log (AEL)</b>— R/W/C. Hardware sets this bit to a 1 when an attempt was made to access the BIOS region using the direct access method or an access to the BIOS Program Registers that violated the security restrictions. This bit is simply a log of an access security violation. This bit is cleared by software writing a 1.</p>



Bit	Description
1	<p><b>Flash Cycle Error (FCERR)</b> — R/W/C. Hardware sets this bit to 1 when an program register access is blocked to the FLASH due to one of the protection policies or when any of the programmed cycle registers is written while a programmed access is already in progress. This bit remains asserted until cleared by software writing a 1 or until hardware reset occurs. Software must clear this bit before setting the FLASH Cycle GO bit in this register.</p> <p>Hardware reset is initiated by one of the following resets:</p> <ul style="list-style-type: none"> <li>Global reset (when the Host and the ME partitions are both reset) - on both ME-enabled and non-ME systems.</li> <li>Host Partition reset (any time PLTRST# is asserted either from a cold or a warm reset) - only on ME enabled systems.</li> </ul>
0	<p><b>Flash Cycle Done (FDONE)</b> — R/W/C. The ICH8 sets this bit to 1 when the SPI Cycle completes after software previously set the FGO bit. This bit remains asserted until cleared by software writing a 1 or hardware reset. When this bit is set and the SPI SMI# Enable bit is set, an internal signal is asserted to the SMI# generation block. Software must make sure this bit is cleared prior to enabling the SPI SMI# assertion for a new programmed access.</p> <p>Hardware reset is initiated by one of the following resets:</p> <ul style="list-style-type: none"> <li>Global reset (when the Host and the ME partitions are both reset) - on both ME-enabled and non-ME systems.</li> <li>Host Partition reset (any time PLTRST# is asserted either from a cold or a warm reset) - only on ME enabled systems.</li> </ul>

### 20.3.3 HSFC—Hardware Sequencing Flash Control Register (GbE LAN Memory Mapped Configuration Registers)

Memory Address: GLBAR + 06h  
 Default Value: 0000h

Attribute: R/W, R/WS  
 Size: 16 bits

Bit	Description
15:10	Reserved
9:8	<p><b>Flash Data Byte Count (FDBC):</b> — R/W. This field specifies the number of bytes to shift in or out during the data portion of the SPI cycle. The content's of this register are 0's based with 0b representing 1 byte and 11b representing 4 bytes. The number of bytes transferred is the value of this field plus 1.</p> <p>This field is ignored for the Block Erase command.</p>



Bit	Description
7:3	Reserved
2:1	<b>FLASH Cycle (FCYCLE).</b> — R/W. This field defines the Flash SPI cycle type generated to the FLASH when the FGO bit is set as defined below: 00 = Read (1 up to 4 bytes by setting FDBC) 01 = Reserved 10 = Write (1 up to 4 bytes by setting FDBC) 11 = Block Erase
0	<b>Flash Cycle Go (FGO):</b> — R/W/S. A write to this register with a '1' in this bit initiates a request to the Flash SPI Arbiter to start a cycle. This register is cleared by hardware when the cycle is granted by the SPI arbiter to run the cycle on the SPI bus. When the cycle is complete, the FDONE bit is set. Software is forbidden to write to any register in the HSFLCTL register between the FGO bit getting set and the FDONE bit being cleared. Any attempt to violate this rule will be ignored by hardware. Hardware allows other bits in this register to be programmed for the same transaction when writing this bit to 1. This saves an additional memory write. This bit always returns 0 on reads.

### 20.3.4 FADDR—Flash Address Register (GbE LAN Memory Mapped Configuration Registers)

Memory Address: GLBAR + 08h                      Attribute:                      R/W  
 Default Value: 00000000h                      Size:                              32 bits

Bit	Description
31:25	Reserved
24:0	<b>Flash Linear Address (FLA):</b> — R/W. The FLA is the starting byte linear address of a SPI Read or Write cycle or an address within a Block for the Block Erase command. The Flash Linear Address must fall within a region for which BIOS has access permissions.

### 20.3.5 FDATA0—Flash Data 0 Register (GbE LAN Memory Mapped Configuration Registers)

Memory Address: GLBAR + 10h                      Attribute:                      R/W  
 Default Value: 00000000h                      Size:                              32 bits

Bit	Description
31:0	<b>Flash Data 0 (FDO):</b> — R/W. This field is shifted out as the SPI Data on the Master-Out Slave-In Data pin during the data portion of the SPI cycle. This register also shifts in the data from the Master-In Slave-Out pin into this register during the data portion of the SPI cycle. The data is always shifted starting with the least significant byte, msb to lsb, followed by the next least significant byte, msb to lsb, etc. Specifically, the shift order on SPI in terms of bits within this register is: 7-6-5-4-3-2-1-0-15-14-13-...8-23-22-...16-31...24 Bit 24 is the last bit shifted out/in. There are no alignment assumptions; byte 0 always represents the value specified by the cycle address. Note that the data in this register may be modified by the hardware during any programmed SPI transaction. Direct Memory Reads do not modify the contents of this register.



## 20.3.6 FRAP—Flash Regions Access Permissions Register (GbE LAN Memory Mapped Configuration Registers)

Memory Address: GLBAR + 50h  
Default Value: 00000808h

Attribute: RO, R/WL  
Size: 32 bits

Bit	Description
31:28	Reserved
27:25	<b>GbE Master Write Access Grant (GMWAG):</b> — R/WL. Each bit [27:25] corresponds to Master[3:1]. GbE can grant one or more masters write access to the GbE region 3 overriding the permissions in the Flash Descriptor. Master[1] is Host CPU/BIOS, Master[2] is ME, Master[3] is Host CPU/GbE. The contents of this register are locked by the FLOCKDN bit.
24:20	Reserved
19:17	<b>GbE Master Read Access Grant (GMRAG):</b> — R/WL. Each bit [19:17] corresponds to Master[3:1]. GbE can grant one or more masters read access to the GbE region 3 overriding the read permissions in the Flash Descriptor. Master[1] is Host CPU/BIOS, Master[2] is ME, Master[3] is GbE. The contents of this register are locked by the FLOCKDN bit.
16:12	Reserved
11:8	<b>GbE Region Write Access (GRWA):</b> — RO. Each bit [11:8] corresponds to Regions [3:0]. If the bit is set, this master can erase and write that particular region through register accesses. The contents of this register are that of the Flash Descriptor. Flash Master 3.Master Region Write Access OR a particular master has granted GbE write permissions in their Master Write Access Grant register OR the Flash Descriptor Security Override strap is set.
7:4	Reserved
3:0	<b>GbE Region Read Access (GRRR):</b> — RO. Each bit [3:0] corresponds to Regions [3:0]. If the bit is set, this master can read that particular region through register accesses. The contents of this register are that of the Flash Descriptor. Flash Master 3.Master Region Write Access OR a particular master has granted GbE read permissions in their Master Read Access Grant register.



### 20.3.7 FREG0—Flash Region 0 (Flash Descriptor) Register (GbE LAN Memory Mapped Configuration Registers)

Memory Address: GLBAR + 54h                      Attribute:                      RO  
Default Value: 00000000h                      Size:                              32 bits

Bit	Description
31:29	Reserved
28:16	<b>Region Limit (RL):</b> — RO. This field specifies address bits 24:12 for the Region 0 Limit. The value in this register is loaded from the contents in the Flash Descriptor.FLREG0.Region Limit.
15:13	Reserved
12:0	<b>Region Base (RB):</b> — RO. This field specifies address bits 24:12 for the Region 0 Base. The value in this register is loaded from the contents in the Flash Descriptor.FLREG0.Region Base.

### 20.3.8 FREG1—Flash Region 1 (BIOS Descriptor) Register (GbE LAN Memory Mapped Configuration Registers)

Memory Address: GLBAR + 58h                      Attribute:                      RO  
Default Value: 00000000h                      Size:                              32 bits

Bit	Description
31:29	Reserved
28:16	<b>Region Limit (RL):</b> — RO. This field specifies address bits 24:12 for the Region 1 Limit. The value in this register is loaded from the contents in the Flash Descriptor.FLREG1.Region Limit
15:13	Reserved
12:0	<b>Region Base (RB):</b> — RO. This field specifies address bits 24:12 for the Region 1 Base. The value in this register is loaded from the contents in the Flash Descriptor.FLREG1.Region Base.



### 20.3.9 FREG2—Flash Region 2 (ME) Register (GbE LAN Memory Mapped Configuration Registers)

Memory Address: GLBAR + 5Ch                      Attribute:                      RO  
 Default Value: 00000000h                      Size:                              32 bits

Bit	Description
31:29	Reserved
28:16	<b>Region Limit (RL):</b> — RO. This field specifies address bits 24:12 for the Region 2 Limit. The value in this register is loaded from the contents in the Flash Descriptor.FLREG2.Region Limit.
15:13	Reserved
12:0	<b>Region Base (RB):</b> — RO. This field specifies address bits 24:12 for the Region 2 Base. The value in this register is loaded from the contents in the Flash Descriptor.FLREG2.Region Base.

### 20.3.10 FREG3—Flash Region 3 (GbE) Register (GbE LAN Memory Mapped Configuration Registers)

Memory Address: GLBAR + 60h                      Attribute:                      RO  
 Default Value: 00000000h                      Size:                              32 bits

Bit	Description
31:29	Reserved
28:16	<b>Region Limit (RL):</b> — RO. This field specifies address bits 24:12 for the Region 3 Limit. The value in this register is loaded from the contents in the Flash Descriptor.FLREG3.Region Limit
15:13	Reserved
12:0	<b>Region Base (RB):</b> — RO. This field specifies address bits 24:12 for the Region 3 Base. The value in this register is loaded from the contents in the Flash Descriptor.FLREG3.Region Base.



### 20.3.11 PR0—Protected Range 0 Register (GbE LAN Memory Mapped Configuration Registers)

Memory Address: GLBAR + 74h                      Attribute:                      R/WL  
Default Value: 00000000h                      Size:                      32 bits

**Note:** This register can not be written when the FLOCKDN bit is set to 1.

Bit	Description
31	<b>Write Protection Enable:</b> — R/WL. When set, this bit indicates that the Base and Limit fields in this register are valid and that writes and erases directed to addresses between them (inclusive) must be blocked by hardware. The base and limit fields are ignored when this bit is cleared.
30:29	Reserved
28:16	<b>Protected Range Limit:</b> — R/WL. This field corresponds to FLA address bits 24:12 and specifies the upper limit of the protected range. Address bits 11:0 are assumed to be FFFh for the limit comparison. Any address greater than the value programmed in this field is unaffected by this protected range.
15	<b>Read Protection Enable:</b> — R/WL. When set, this bit indicates that the Base and Limit fields in this register are valid and that read directed to addresses between them (inclusive) must be blocked by hardware. The base and limit fields are ignored when this bit is cleared.
14:13	Reserved
12:0	<b>Protected Range Base:</b> — R/WL. This field corresponds to FLA address bits 24:12 and specifies the lower base of the protected range. Address bits 11:0 are assumed to be 000h for the base comparison. Any address less than the value programmed in this field is unaffected by this protected range.

### 20.3.12 PR1—Protected Range 1 Register (GbE LAN Memory Mapped Configuration Registers)

Memory Address: GLBAR + 78h                      Attribute:                      R/WL  
Default Value: 00000000h                      Size:                      32 bits

**Note:** This register can not be written when the FLOCKDN bit is set to 1.

Bit	Description
31	<b>Write Protection Enable:</b> — R/WL. When set, this bit indicates that the Base and Limit fields in this register are valid and that writes and erases directed to addresses between them (inclusive) must be blocked by hardware. The base and limit fields are ignored when this bit is cleared.
30:29	Reserved
28:16	<b>Protected Range Limit:</b> — R/WL. This field corresponds to FLA address bits 24:12 and specifies the upper limit of the protected range. Address bits 11:0 are assumed to be FFFh for the limit comparison. Any address greater than the value programmed in this field is unaffected by this protected range.
15	<b>Read Protection Enable:</b> — R/WL. When set, this bit indicates that the Base and Limit fields in this register are valid and that read directed to addresses between them (inclusive) must be blocked by hardware. The base and limit fields are ignored when this bit is cleared.
14:13	Reserved
12:0	<b>Protected Range Base:</b> — R/WL. This field corresponds to FLA address bits 24:12 and specifies the lower base of the protected range. Address bits 11:0 are assumed to be 000h for the base comparison. Any address less than the value programmed in this field is unaffected by this protected range.





### 20.3.13 SSFS—Software Sequencing Flash Status Register (GbE LAN Memory Mapped Configuration Registers)

Memory Address: GLBAR + 90h  
Default Value: 00h

Attribute: RO, R/WC  
Size: 8 bits

**Note:** The Software Sequencing control and status registers are reserved if the hardware sequencing control and status registers are used.

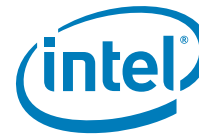
Bit	Description
7:5	Reserved
4	<b>Access Error Log (AEL):</b> — RO. This bit reflects the value of the Hardware Sequencing Status AEL register.
3	<b>Flash Cycle Error (FCERR):</b> — R/WC. Hardware sets this bit to 1 when a programmed access is blocked from running on the SPI interface due to one of the protection policies or when any of the programmed cycle registers is written while a programmed access is already in progress. This bit remains asserted until cleared by software writing a 1 or hardware reset. Hardware reset is initiated by one of the following resets: <ul style="list-style-type: none"> <li>Global reset (when the Host and the ME partitions are both reset) - on both ME-enabled and non-ME systems.</li> <li>Host Partition reset (any time PLTRST# is asserted either from a cold or a warm reset) - only on ME enabled systems.</li> </ul>
2	<b>Cycle Done Status:</b> — R/WC. The ICH8 sets this bit to 1 when the SPI Cycle completes (i.e., SCIP bit is 0) after software sets the GO bit. This bit remains asserted until cleared by software writing a 1 or hardware reset. When this bit is set and the SPI SMI# Enable bit is set, an internal signal is asserted to the SMI# generation block. Software must make sure this bit is cleared prior to enabling the SPI SMI# assertion for a new programmed access. Hardware reset is initiated by one of the following resets: <ul style="list-style-type: none"> <li>Global reset (when the Host and the ME partitions are both reset) - on both ME-enabled and non-ME systems.</li> <li>Host Partition reset (any time PLTRST# is asserted either from a cold or a warm reset) - only on ME enabled systems.</li> </ul>
1	Reserved
0	<b>SPI Cycle In Progress (SCIP):</b> — RO. Hardware sets this bit when software sets the SPI Cycle Go bit in the Command register. This bit remains set until the cycle completes on the SPI interface. Hardware automatically sets and clears this bit so that software can determine when read data is valid and/or when it is safe to begin programming the next command. Software must only program the next command when this bit is 0.



### 20.3.14 SSFC—Software Sequencing Flash Control Register (GbE LAN Memory Mapped Configuration Registers)

Memory Address: GLBAR + 91h                      Attribute:                      R/W  
 Default Value: 000000h                      Size:                      24 bits

Bit	Description
23:19	Reserved
18:16	<p><b>SPI Cycle Frequency (SCF):</b> — R/W.            000 = 20 MHz            001 = 33 MHz            All other values reserved            Software should program this register to set the frequency of the cycle that is to be run.</p>
15	Reserved
14	<p><b>Data Cycle (DS):</b> — R/W. When set to 1, there is data that corresponds to this transaction. When 0, no data is delivered for this cycle, and the DBC and data fields themselves are do not cares</p>
13:8	<p><b>Data Byte Count (DBC):</b> — R/W. This field specifies the number of bytes to shift in or out during the data portion of the SPI cycle. The valid settings (in decimal) are any value from 0 to 3. The number of bytes transferred is the value of this field plus 1. Note that when this field is 00b, then there is 1 byte to transfer and that 11b means there are 4 bytes to transfer.</p>
7	Reserved
6:4	<p><b>Cycle Opcode Pointer (COP):</b> — R/W. This field selects one of the programmed opcodes in the Opcode Menu to be used as the SPI Command/Opcode. In the case of an Atomic Cycle Sequence, this determines the second command.</p>
3	<p><b>Sequence Prefix Opcode Pointer (SPOP):</b> — R/W. This field selects one of the two programmed prefix opcodes for use when performing an Atomic Cycle Sequence. A value of 0 points to the opcode in the least significant byte of the Prefix Opcodes register. By making this programmable, the ICH8 supports flash devices that have different opcodes for enabling writes to the data space vs. status register.</p>
2	<p><b>Atomic Cycle Sequence (ACS):</b> — R/W. When set to 1 along with the SCGO assertion, the ICH8 will execute a sequence of commands on the SPI interface without allowing the LAN component to arbitrate and interleave cycles. The sequence is composed of:</p> <ul style="list-style-type: none"> <li>• Atomic Sequence Prefix Command (8-bit opcode only)</li> <li>• Primary Command specified below by software (can include address and data)</li> <li>• Polling the Flash Status Register (opcode 05h) until bit 0 becomes 0b.</li> </ul> <p>The SPI Cycle in Progress bit remains set and the Cycle Done Status bit remains unset until the Busy bit in the Flash Status Register returns 0.</p>
1	<p><b>SPI Cycle Go (SCGO):</b> — R/WS. This bit always returns 0 on reads. However, a write to this register with a 1 in this bit starts the SPI cycle defined by the other bits of this register. The “SPI Cycle in Progress” (SCIP) bit gets set by this action. Hardware must ignore writes to this bit while the Cycle In Progress bit is set.            Hardware allows other bits in this register to be programmed for the same transaction when writing this bit to 1. This saves an additional memory write.</p>
0	Reserved



### 20.3.15 PREOP—Prefix Opcode Configuration Register (GbE LAN Memory Mapped Configuration Registers)

Memory Address: GLBAR + 94h                      Attribute:              R/W  
 Default Value:    0000h                              Size:                      16 bits

Bit	Description
15:8	<b>Prefix Opcode 1</b> — R/W. Software programs an SPI opcode into this field that is permitted to run as the first command in an atomic cycle sequence.
7:0	<b>Prefix Opcode 0</b> — R/W. Software programs an SPI opcode into this field that is permitted to run as the first command in an atomic cycle sequence.

**NOTE:** This register is not writable when the SPI Configuration Lock-Down bit (GLBAR + 00h:15) is set.

### 20.3.16 OPTYPE—Opcode Type Configuration Register (GbE LAN Memory Mapped Configuration Registers)

Memory Address: GLBAR + 96h                      Attribute:              R/W  
 Default Value:    0000h                              Size:                      16 bits

Entries in this register correspond to the entries in the Opcode Menu Configuration register.

**Note:** The definition below only provides write protection for opcodes that have addresses associated with them. Therefore, any erase or write opcodes that do not use an address should be avoided (for example, “Chip Erase” and “Auto-Address Increment Byte Program”).

Bit	Description
15:14	<b>Opcode Type 7</b> — R/W. See the description for bits 1:0
13:12	<b>Opcode Type 6</b> — R/W. See the description for bits 1:0
11:10	<b>Opcode Type 5</b> — R/W. See the description for bits 1:0
9:8	<b>Opcode Type 4</b> — R/W. See the description for bits 1:0
7:6	<b>Opcode Type 3</b> — R/W. See the description for bits 1:0
5:4	<b>Opcode Type 2</b> — R/W. See the description for bits 1:0
3:2	<b>Opcode Type 1</b> — R/W. See the description for bits 1:0
1:0	<p><b>Opcode Type 0</b> — R/W. This field specifies information about the corresponding Opcode 0. This information allows the hardware to 1) know whether to use the address field and 2) provide BIOS and Shared Flash protection capabilities. The encoding of the two bits is:</p> <p>00 = No address associated with this Opcode; Read cycle type            01 = No address associated with this Opcode; Write cycle type            10 = Address required; Read cycle type            11 = Address required; Write cycle type</p>

**NOTE:** This register is not writable when the SPI Configuration Lock-Down bit (GLBAR + 00h:15) is set.



### 20.3.17 OPMENU—Opcode Menu Configuration Register (GbE LAN Memory Mapped Configuration Registers)

Memory Address: GLBAR + 98h                      Attribute:                      R/W  
Default Value: 0000000000000000h              Size:                              64 bits

Eight entries are available in this register to give GbE a sufficient set of commands for communicating with the flash device, while also restricting what malicious software can do. This keeps the hardware flexible enough to operate with a wide variety of SPI devices.

**Note:** It is recommended that GbE avoid programming Write Enable opcodes in this menu. Malicious software could then perform writes and erases to the SPI flash without using the atomic cycle mechanism. This could cause functional failures in a shared flash environment. Write Enable opcodes should only be programmed in the Prefix Opcodes.

Bit	Description
63:56	<b>Allowable Opcode 7</b> — R/W. See the description for bits 7:0
55:48	<b>Allowable Opcode 6</b> — R/W. See the description for bits 7:0
47:40	<b>Allowable Opcode 5</b> — R/W. See the description for bits 7:0
39:32	<b>Allowable Opcode 4</b> — R/W. See the description for bits 7:0
31:24	<b>Allowable Opcode 3</b> — R/W. See the description for bits 7:0
23:16	<b>Allowable Opcode 2</b> — R/W. See the description for bits 7:0
15:8	<b>Allowable Opcode 1</b> — R/W. See the description for bits 7:0
7:0	<b>Allowable Opcode 0</b> — R/W. Software programs an SPI opcode into this field for use when initiating SPI commands through the Control Register.

This register is not writable when the SPI Configuration Lock-Down bit (GLBAR + 00h:15) is set.





# 21 Thermal Sensor Registers (D31:F6)

## 21.1 PCI Bus Configuration Registers

Table 145. Thermal Sensor Register Address Map (D31:F6)

Offset	Mnemonic	Register Name	Default	Type
00h–01h	VID	Vendor Identification	8086h	RO
02h–03h	DID	Device Identification	284Fh	RO
04h–05h	CMD	Command	0000h	R/W, RO
06h–07h	STS	Device Status	0010h	R/WC, RO
08h	RID	Revision ID	00h	RO
09h	PI	Programming Interface	00h	RO
0Ah	SCC	Sub Class Code	80h	RO
0Bh	BCC	Base Class Code	11h	RO
0Ch	CLS	Cache Line Size	00h	RO
0Dh	LT	Latency Timer	00h	RO
0Eh	HTYPE	Header Type	00h	RO
0Fh	BIST	Built-in Self Test	00h	RO
10h–13h	TBAR	Thermal Base Address (Memory)	00000004h	R/W, RO
14h–17h	TBARH	Thermal Base Address High DWord	00000000h	RO
2Ch–2Dh	SVID	Subsystem Vendor Identifier	0000h	R/WO
2Eh–2Fh	SID	Subsystem Identifier	0000h	R/WO
34h	CAP_PTR	Capabilities Pointer	50h	RO
3Ch	INTLN	Interrupt Line	00h	R/W
3Dh	INTPN	Interrupt Pin	03h	RO
40h–43h	TBARB	BIOS Assigned Thermal Base Address	00000004h	R/W, RO
44h–47h	TBARBH	BIOS Assigned BA High DWord	00000000h	R/W
50h–51h	PID	Power Management Identifiers	0001h	RO
52h–53h	PC	Power Management Capabilities	0022h	RO
54h–57h	PCS	Power Management Control and Status	0000h	R/W, RO



### 21.1.1 VID—Vendor Identification

Offset Address:	00h–01h	Attribute:	RO
Default Value:	8086h	Size:	16 bit
Lockable:	No	Power Well:	Core

Bit	Description
15:0	<b>Vendor ID</b> — RO. This is a 16-bit value assigned to Intel. Intel VID = 8086h

### 21.1.2 DID—Device Identification

Offset Address:	02h–03h	Attribute:	RO
Default Value:	284Fh	Size:	16 bit

Bit	Description
15:0	<b>Device ID (DID)</b> — RO. This field indicates the device number assigned by the SIG.

### 21.1.3 CMD—Command

Address Offset:	04h–05h	Attribute:	RO, R/W
Default Value:	0000h	Size:	16 bits

Bit	Description
15:11	Reserved
10	<b>Interrupt Disable (ID)</b> — R/W. This bit enables the device to assert an INTx#. When set, the Thermal logic's INTx# signal will be de-asserted. When cleared, the INTx# signal may be asserted.
9	<b>FBE (Fast Back to Back Enable)</b> — RO. Not implemented. Hardwired to 0.
8	<b>SEN (SERR Enable)</b> — RO. Not implemented. Hardwired to 0.
7	<b>WCC (Wait Cycle Control)</b> — RO. Not implemented. Hardwired to 0.
6	<b>PER (Parity Error Response)</b> — RO. Not implemented. Hardwired to 0.
5	<b>VPS (VGA Palette Snoop)</b> — RO. Not implemented. Hardwired to 0.
4	<b>MWI (Memory Write and Invalidate Enable)</b> — RO. Not implemented. Hardwired to 0.
3	<b>SCE (Special Cycle Enable)</b> — RO. Not implemented. Hardwired to 0.
2	<b>BME (Bus Master Enable)</b> — RO. Not implemented. Hardwired to 0.
1	<b>Memory Space Enable (MSE)</b> — R/W. When set, enables memory space accesses to the Thermal registers.
0	<b>IOS (I/O Space)</b> — RO. The Thermal logic does not implement I/O Space; therefore, this bit is hardwired to 0.



### 21.1.4 STS—Status

Address Offset: 06h–07h                      Attribute:                      R/WC, RO  
 Default Value: 0010h                      Size:                      16 bits

Bit	Description
15	<b>Detected Parity Error (DPE)</b> — R/WC. Software clears this bit by writing a 1 to this bit location. 0 = Parity did Not occur. 1 = Parity error occurs on the internal interface for this function, regardless of the setting of bit 6 in the Command register.
14	<b>SERR# Status (SERRS)</b> — RO. Not implemented. Hardwired to 0.
13	<b>Received Master Abort (RMA)</b> — RO. Not implemented. Hardwired to 0.
12	<b>Received Target Abort (RTA)</b> — RO. Not implemented. Hardwired to 0.
11	<b>Signaled Target-Abort (STA)</b> — RO. Not implemented. Hardwired to 0.
10:9	<b>DEVSEL# Timing Status (DEVT)</b> — RO. Does not apply. Hardwired to 0.
8	<b>Master Data Parity Error (MDPE)</b> — RO. Not implemented. Hardwired to 0.
7	<b>Fast Back to Back Capable (FBC)</b> — RO. Does not apply. Hardwired to 0.
6	Reserved
5	<b>66 MHz Capable (C66)</b> — RO. Does not apply. Hardwired to 0.
4	<b>Capabilities List Exists (CLIST)</b> — RO. This bit indicates that the controller contains a capabilities pointer list. The first item is pointed to by looking at configuration offset 34h.
3	<b>Interrupt Status (IS)</b> — RO. This bit reflects the state of the INTx# signal at the input of the enable/disable circuit. This bit is a 1 when the INTx# is asserted. This bit is a 0 after the interrupt is cleared (independent of the state of the Interrupt Disable bit in the command register).
2:0	Reserved

### 21.1.5 RID—Revision Identification

Address Offset: 08h                      Attribute:                      RO  
 Default Value: 00h                      Size:                      8 bits

Bit	Description
7:0	<b>Revision ID (RID)</b> — RO. This field indicates the device specific revision identifier.

### 21.1.6 PI— Programming Interface

Address Offset: 09h                      Attribute:                      RO  
 Default Value: 00h                      Size:                      8 bits

Bit	Description
7:0	<b>Programming Interface (PI)</b> — RO. ICH8 Thermal logic has no standard programming interface.









### 21.1.15 SVID—Subsystem Vendor ID

Address Offset: 2Ch–2Dh                      Attribute: R/WO  
Default Value: 0000h                      Size: 16 bits

This register should be implemented for any function that could be instantiated more than once in a given system,. The SVID register, in combination with the Subsystem ID register, enables the operating environment to distinguish one subsystem from the other(s).

Software (BIOS) will write the value to this register. After that, the value can be read, but writes to the register will have no effect. The write to this register should be combined with the write to the SID to create one 32-bit write. This register is not affected by D3<sub>HOT</sub> to D0 reset.

Bit	Description
15:0	<b>SVID (SVID)</b> — R/WO. These R/WO bits have no ICH8 functionality.

### 21.1.16 SID—Subsystem ID

Address Offset: 2Eh–2Fh                      Attribute: R/WO  
Default Value: 0000h                      Size: 16 bits

This register should be implemented for any function that could be instantiated more than once in a given system,. The SID register, in combination with the Subsystem Vendor ID register, make it possible for the operating environment to distinguish one subsystem from the other(s).

Software (BIOS) will write the value to this register. Then, the value can be read, but writes to the register will have no effect. The write to this register should be combined with the write to the SVID to create one 32-bit write. This register is not affected by D3<sub>HOT</sub> to D0 reset.

Bit	Description
15:0	<b>SID (SID)</b> — R/WO. These R/WO bits have no ICH8 functionality.

### 21.1.17 CAP\_PTR —Capabilities Pointer

Address Offset: 34h                              Attribute: RO  
Default Value: 50h                              Size: 8 bits

Bit	Description
7:0	<b>Capability Pointer (CP)</b> — RO. This field indicates that the first capability pointer offset is offset 50h (Power Management Capability).

### 21.1.18 INTLN—Interrupt Line

Address Offset: 3Ch                              Attribute: R/W  
Default Value: 00h                              Size: 8 bits

Bit	Description
7:0	<b>Interrupt Line</b> — R/W. The ICH8 hardware does not use this field directly. It is used to communicate to software the interrupt line that the interrupt pin is connected to.









## 21.2 Thermal Memory Mapped Configuration Registers (Thermal Sensor - D31:F26)

The base memory for these thermal memory mapped configuration registers is specified in the TBARB (D31:F6, Offset 40h). The individual registers are then accessible at TBARB + Offset.

There are two sensors in the ICH8. Each sensor has a separate configuration register set. Both sensors must be configured together.

### 21.2.1 TSxE—Thermal Sensor [1:0] Enable

Offset Address:	Sensor 0: TBARB+01h	Attribute:	R/W
	Sensor 1: TBARB+41h		
Default Value:	00h	Size:	8 bit

Bit	Description
7:0	<b>Thermal Sensor Enable (TSE)</b> — R/W. BIOS shall always program this register to the value BAh to enable the thermal sensor. All other values are reserved.

### 21.2.2 TSxS—Thermal Sensor[1:0] Status

Offset Address:	Sensor 0: TBARB+02h	Attribute:	RO
	Sensor 1: TBARB+42h		
Default Value:	00h	Size:	8 bit

Bit	Description
7	<b>Catastrophic Trip Indicator (CTI)</b> — RO. 1 = Temperature is above the catastrophic setting. 0 = Temperature is below the catastrophic setting.
6:0	Reserved

### 21.2.3 TSxTTP—Thermal Sensor [1:0] Catastrophic Trip Point

Offset Address:	Sensor 0: TBARB+04h	Attribute:	R/W
	Sensor 1: TBARB+44h		
Default Value:	00h	Size:	32 bit

Bit	Description
31:8	Reserved
7:0	<b>Catastrophic Trip Point Setting (CTPS)</b> — R/W. These bits set the catastrophic trip point. BIOS must write a value of 0Ah to offset 04h and a value of 0Bh to offset 44h to set the trip point. These bits are lockable via TSxCO.bit 7.



### 21.2.4 TSxCO—Thermal Sensor [1:0] Catastrophic Lock-Down

Offset Address: Sensor 0: TBARB+08h      Attribute: R/W  
 Sensor 1: TBARB+48h  
 Default Value: 00h      Size: 8 bit

Bit	Description
7	<b>Lock bit for Catastrophic (LBC)</b> — R/W. This bit may only be set to a 0 by a hardware reset. Writing a 0 to this bit has no effect. 1 = Locks the Catastrophic programming interface including TSxTTP.bits[7:0]. 0 = Catastrophic programming interface is unlocked
6:0	Reserved

### 21.2.5 TSxPC—Thermal Sensor [1:0] Policy Control

Offset Address: Sensor 0: TBARB+0Eh      Attribute: R/W  
 Sensor 1: TBARB+4Eh  
 Default Value: 00h      Size: 8 bit

Bit	Description
7	<b>Policy Lock-Down Bit</b> — R/W. This bit may only be set to a 0 by a hardware reset. Writing a 0 to this bit has no effect. 1 = Prevents writes to this register. 0 = This register can be programmed and modified.  <b>NOTE:</b> TSxCO.bit 7 and TSxLOCK.bit 2 must also be 1 when this bit is set to 1.
6	<b>Catastrophic Power-Down Enable</b> — R/W. 0 = Disable 1 = Enable. Power management logic unconditionally transitions to the S5 state when a catastrophic temperature is detected by the sensor.
5:0	Reserved

### 21.2.6 TSxLOCK—Thermal Sensor [1:0] Register Lock Control

Offset Address: Sensor 0: TBARB+83h      Attribute: R/W  
 Sensor 1: TBARB+C3h  
 Default Value: 00h      Size: 8 bit

Bit	Description
7:3	Reserved
2	<b>Lock Control</b> — R/W. This bit must be set to 1 when TSxPC.bit7 is set to 1.
1:0	Reserved

§ §







## 22 Ballout Definition

---

This chapter contains the Intel® ICH8 ballout information.

### 22.1 Ballout (Desktop Only)

Figure 18 and Figure 19 show the top view ballout for the 82801HB ICH8 and 82801HR ICH8R and 82801HDH ICH8DH and 82801HDO ICH8DO components. Table 146 provides the ballout, organized alphabetically by signal name.

**Note:** "\*\*\*" indicates signals that are not on the ICH8 Base component. Since SATA ports 2 and 3 are not on ICH8 Base, the balls for the following signal names are Reserved on the ICH8 Base component.  
SATA2TXP/SATA2TXN, SATA2RXP/SATA2RXN, SATA2GP, SATA3TXP/SATA3TXN, SATA3GP, and SATA3RXP/SATA3RXN are Reserved.

**Note:** "\*" indicates signals that are only on the 82801HDH ICH8DH



Figure 18. Ballout (Top View–Left Side) (Desktop Only)

	1	2	3	4	5	6	7	8	9	10	11	12	13	14					
A	PWRBTN#	V5REF_Sus	PIROC#	GNT0#	Vss	Vcc3_3	TRDY#	PIROD#	REQ3#/GPIO54	C/BE1#	AD14	C/BE3#	AD8	AD2	A				
B	CLK48	Vss	FWH4/LFRAME#	Vcc3_3	AD28	IRDY#	AD26	Vss	GNT3#/GPIO55	PCICLK	Vss	DEVSEL#	AD4	Vss	B				
C	VccUSBPLL	CLPWROK	LDRQ1#/GPIO23	PIROA#	PIROB#	AD27	AD24	Vcc3_3	PERR#	Vcc3_3	AD16	C/BE2#	AD11	AD9	C				
D	Vcc1_5_A	Vss	PME#	Vss	PIROE#/GPIO2	Vss	AD23	AD22	PAR	AD15	PLOCK#	Vss	AD19	Vcc3_3	D				
E	USBRBIAS#	USBRBIAS	PCIRST#	SUSCLK	FWH3/LAD3	SERR#	AD31	REQ0#	Vss	Vcc3_3	AD21	AD18	AD17	AD10	E				
F	CK_PWRGD	Vss	VccSus3_3	Vss	FWH1/LAD1	FWH0/LAD0	Vss	AD30	PIROH#/GPIO5	PIROF#/GPIO3	Vcc3_3	AD29	AD25	AD20	F				
G	Vss	USBP0N	USBP0P	Vss	Vss	Vss	SUS_STAT#/LPCPD	LDRQ0#	FWH2/LAD2	Vss	PIROG#/GPIO4	Vcc1_5_A	Vss	Vcc3_3	G				
H	USBP2N	USBP2P	Vss	USBP1P	USBP1N	Vss	Vss								H				
J	Vss	USBP3P	USBP3N	Vss	Vss	VccSus1_05	VccSus1_5								J				
K	USBP5N	USBP5P	Vss	USBP4P	USBP4N	Vss	Vss								K				
L	Vss	USBP6P	USBP6N	Vss	Vss	Vcc1_5_A	Vcc1_5_A								Vcc1_05	Vcc1_05	Vss	Vcc1_05	L
M	USBP8P	USBP8N	Vss	USBP7P	USBP7N	Vcc1_5_A	Vcc1_5_A								Vcc1_05	Vss	Vss	Vss	M
N	Vss	USBP9N	USBP9P	Vss	Vss	VccSus3_3	VccSus3_3								Vss	Vss	Vss	Vss	N
P	VccSus3_3	VccSus3_3	VccSus3_3	Vss	Vcc3_3	VccSus3_3	VccSus3_3								Vcc1_05	Vss	Vss	Vss	P
R	SATARBIAS	SATARBIAS#	VccSus3_3	VccSus3_3	VccSus3_3	VccSus3_3	VccSus3_3								Vss	Vss	Vss	Vss	R
T	SATA5RXN	SATA5RXP	Vss	Vss	Vss	Vss	Vcc1_5_A								Vcc1_05	Vss	Vss	Vss	T
U	Vss	Vss	SATA4TXN	SATA4TXP	Vcc1_5_A	Vcc1_5_A	Vcc1_5_A								Vcc1_05	Vss	Vss	Vss	U
V	SATA5TXP	SATA5TXN	Vcc1_5_A	Vcc1_5_A	Vcc1_5_A	Vcc1_5_A	Vss	V											
W	Vcc1_5_A	Vcc1_5_A	Vcc1_5_A	SATA2RXP**	SATA2RXN*	Vcc1_5_A	Vcc1_5_A	W											
Y	SATA4RXN	SATA4RXP	Vss	Vss	Vss	Vcc1_5_A	Vcc1_5_A	Y											
AA	Vss	Vss	SATA2TXN*	SATA2TXP**	Vcc1_5_A	Vcc1_5_A	Vcc1_5_A	AA											
AB	SATA3RXN**	SATA3RXP**	Vcc1_5_A	Vcc1_5_A	Vcc1_5_A	PWM0	Vcc3_3	PWM2	Vcc1_5_A	SATALED#	SATAOGP/GPIO21	Vss	Vcc1_5_A	VccSusHDA	AB				
AC	Vcc1_5_A	Vcc1_5_A	Vcc1_5_A	SATAORXP	SATAORXN	Vss	TACH0/GPIO17	TACH3/GPIO7	Vss	SDATAOUT0/GPIO39	GPIO18	INIT3_3V#	VccHDA	HDA_SDIN1	AC				
AD	SATA3TXP**	SATA3TXN**	Vss	Vss	Vss	PWM1	Vcc3_3	SATA1GP/GPIO19	SATA3GP*/GPIO37	SATA4GP	Vss	SATACLKREQ#/GPIO35	HDA_SDIN3	OC8#	AD				
AE	Vss	Vss	SATA0TXP	SATA0TXN	Vss	TACH2/GPIO6	SCLOCK/GPIO22	Vss	SATA5GP	MCH_SYNC#	GPIO16	Vcc3_3	HDA_SDIN0	Vss	AE				
AF	SATA1RXN	SATA1RXP	Vss	Vss	TACH1/GPIO1	SPKR	SDATAOUT1/GPIO48	SATA2GP**/GPIO36	GPIO0	RCIN#	Vcc3_3	HDA_BIT_CLK	HDA_RST#	OC7#/GPIO31	AF				
AG	Vss	Vss	SATA_CLKN	SATA_CLKP	Vss	CLK14	GPIO33	GPIO20	SERIRQ	A20GATE	Vss	GPIO34	OC6#/GPIO30	OC2#/GPIO41	AG				
AH	SATA1TXP	SATA1TXN	Vss	Vss	VccSATAPLL	SLOAD/GPIO38	GPIO32	Vss	THRMR#	HDA_SYNC	HDA_SDOUT	HDA_SDIN2	Vss	OC1#/GPIO40	AH				



Figure 19. Ballout (Top View–Right Side) (Desktop Only)

	15	16	17	18	19	20	21	22	23	24	25	26	27	28					
A	V5REF	AD1	AD3	SPI_CS1#	SPI_CLK	VccCL1_05	VccCL1_5	VccGLAN3_3	Vcc1_05	Vss	VccGLANPLL	VccGLAN1_5	VccGLAN1_5	Vss	A				
B	Vcc3_3	REQ2#/GPIO52	Vss	Vcc3_3	SPI_MISO	Vss	CL_VREF	Vss	Vcc1_05	Vss	VccGLAN1_5	VccGLAN1_5	PETp6/GLAN_TXP	PETn6/GLAN_TXN	B				
C	GNT1#/GPIO51	REQ1#/GPIO50	AD7	LAN_TXD1	LAN_RXD1	LAN_TXD0	SPI_CS0#	Vss	Vcc1_05	GLAN_COMPO	PERp6/GLAN_RXP	PERn6/GLAN_RXN	Vss	Vss	C				
D	STOP#	Vss	GNT2#/GPIO53	LAN_TXD2	Vss	LAN_RXD2	SPI_MOSI	Vss	Vcc1_05	GLAN_COMPI	Vss	Vss	PETp5	PETn5	D				
E	AD12	FRAME#	AD6	AD0	LAN_RXD0	LAN_RSTSYNC	Vss	GLAN_CLK	Vcc1_05	Vss	PERp5	PERn5	Vss	Vss	E				
F	Vss	AD13	VccLAN1_05	AD5	VccLAN3_3	VccCL3_3	CL_CLK	Vss	Vcc1_05	Vss	Vss	Vss	PETp4	PETn4	F				
G	Vcc1_5_A	C/BEO#	VccLAN1_05	Vss	VccLAN3_3	VccCL3_3	CL_DATA	Vcc1_05	Vcc1_05	Vss	PERp4	PERn4	Vss	Vss	G				
H								Vcc1_05	Vss	Vss	Vss	Vss	PETp3	PETn3	H				
J								Vcc1_5_B	Vcc1_5_B	Vcc1_5_B	PERp3	PERn3	Vss	Vss	J				
K								Vcc1_5_B	Vcc1_5_B	Vcc1_5_B	Vss	Vss	PETp2	PETn2	K				
L	Vss	Vcc1_05	Vcc1_05	Vcc1_05								Vcc1_5_B	Vcc1_5_B	Vcc1_5_B	PERn2	PERp2	Vss	Vss	L
M	Vss	Vss	Vss	Vcc1_05								Vss	Vcc1_5_B	Vcc1_5_B	Vss	Vss	PETp1	PETn1	M
N	Vss	Vss	Vss	Vss								Vcc1_5_B	Vcc1_5_B	Vcc1_5_B	PERn1	PERp1	Vss	Vss	N
P	Vss	Vss	Vss	Vcc1_05								Vss	Vcc1_5_B	Vcc1_5_B	Vcc1_5_B	Vcc1_5_B	Vss	VccDMIPLL	P
R	Vss	Vss	Vss	Vss								Vcc1_5_B	Vcc1_5_B	DMI_CLKP	DMI_CLKN	Vcc1_5_B	Vcc1_5_B	Vcc1_5_B	R
T	Vss	Vss	Vss	Vcc1_05								Vss	Vcc1_5_B	Vcc1_5_B	Vss	Vss	DMIOTXP	DMIOTXN	T
U	Vss	Vss	Vss	Vcc1_05								Vcc1_5_B	Vcc1_5_B	Vcc1_5_B	DMIORXP	DMIORXN	Vss	Vss	U
V	Vss	Vcc1_05	Vcc1_05	Vcc1_05								Vss	Vcc1_5_B	Vcc1_5_B	Vss	Vss	DMI1TXP	DMI1TXN	V
W								Vcc1_5_B	Vcc1_5_B	Vcc1_5_B	DMI1RXP	DMI1RXN	Vss	Vss	W				
Y								Vcc1_5_A	Vcc1_5_B	Vcc1_5_B	Vcc1_5_B	Vcc1_5_B	DMI2TXP	DMI2TXN	Y				
AA								INTVRMEN	Vss	DMI2RXP	DMI2RXN	Vcc1_5_B	Vcc1_5_B	Vcc1_5_B	AA				
AB	VccSus1_5	VccSus3_3	VccSus1_05	SMBDATA	INIT#	SMI#	VccSus3_3	FERR#	STPCLK#	Vss	Vss	Vss	DMI3TXP	DMI3TXN	AB				
AC	Vss	VRMPWRGD	SLP_S5#	Vss	GPIO12	VccSus3_3	Vss	IGNNE#	NMI	CPUSLP#	DMI3RXP	DMI3RXN	Vss	Vss	AC				
AD	ORT_STATE1*/GPIO28	TP3	SST	VccSus3_3	SMBCLK	ORT_STATE0*/GPIO27	RTCST#	RSMRST#	A20M#	TP2	V_CPU_IO	Vss	DMI_ZCOMP	DMI_IRCOMP	AD				
AE	OC5#/GPIO29	GPIO8	Vss	TP4	SMLINK0	Vss	GPIO15	TP0	Vss	PWROK	TP1	V_CPU_IO	VccDMI	VccDMI	AE				
AF	OC0#	SYS_RESET#	LAN_RST#	GPIO13	VccSus3_3	ALERT#/GPIO10	SMBALERT#/GPIO11	SLP_S3#	PLTRST#	INTRUDER#	CPUPWRGD/GPIO49	PECI	Vss	Vcc3_3	AF				
AG	OC3#/GPIO42	OC9#	RI#	WOL_ENABLE/GPIO9	CL_RST#	TP6	SMLINK1	SLP_M#	CLGPIO/GPIO24	LAN100_SLP	Vss	VccRTC	Vss	THRMTrip#	AG				
AH	OC4#/GPIO43	Vss	GPIO25	WAKE#	Vss	TP5	LINKALERT#	Vss	SLP_S4#	NETDETECT/GPIO14	S4_STATE#/GPIO26	RTCX1	RTCX2	INTR	AH				



**Table 146. Ballout by Signal Name (Desktop Only)**

Ball Name	Ball #
A20GATE	AG10
A20M#	AD23
AD0	E18
AD1	A16
AD2	A14
AD3	A17
AD4	B13
AD5	F18
AD6	E17
AD7	C17
AD8	A13
AD9	C14
AD10	E14
AD11	C13
AD12	E15
AD13	F16
AD14	A11
AD15	D10
AD16	C11
AD17	E13
AD18	E12
AD19	D13
AD20	F14
AD21	E11
AD22	D8
AD23	D7
AD24	C7
AD25	F13
AD26	B7
AD27	C6
AD28	B5
AD29	F12
AD3	A17
AD30	F8
AD31	E7
C/BE1#	A10
C/BE2#	C12
C/BE3#	A12
CK_PWRGD	F1

**Table 146. Ballout by Signal Name (Desktop Only)**

Ball Name	Ball #
CL_CLK0	F21
CL_DATA0	G21
CL_RST#	AG19
CL_VREF0	B21
CLGPIO0/GPIO24	AG23
ALERT#/GPIO10	AF20
NETDETECT / GPIO14	AH24
CLK14	AG6
CLK48	B1
CLPWROK	C2
CPUPWRGD/ GPIO49	AF25
CPUSLP#	AC24
DEVSEL#	B12
DMI_CLKN	R25
DMI_CLKP	R24
DMI_IRCOMP	AD28
DMI_ZCOMP	AD27
DMIORXN	U26
DMIORXP	U25
DMIOTXN	T28
DMIOTXP	T27
DMI1RXN	W26
DMI1RXP	W25
DMI1TXN	V28
DMI1TXP	V27
DMI2RXN	AA25
DMI2RXP	AA24
DMI2TXN	Y28
DMI2TXP	Y27
DMI3RXN	AC26
DMI3RXP	AC25
DMI3TXN	AB28
DMI3TXP	AB27
FERR#	AB22
FRAME#	E16
FWH0/LAD0	F6
FWH1/LAD1	F5
FWH2/LAD2	G9

**Table 146. Ballout by Signal Name (Desktop Only)**

Ball Name	Ball #
FWH3/LAD3	E5
FWH4/LFRAME#	B3
GLAN_CLK	E22
GLAN_COMPI	D24
GLAN_COMPO	C24
GNT0#	A4
GNT1#/GPIO51	C15
GNT2#/GPIO53	D17
GNT3#/GPIO55	B9
GPIO0	AF9
GPIO8	AE16
GPIO12	AC19
GPIO13	AF18
GPIO15	AE21
GPIO16	AE11
GPIO18	AC11
GPIO20	AG8
GPIO25	AH17
GPIO32	AH7
GPIO33	AG7
GPIO34	AG12
HDA_BIT_CLK	AF12
HDA_RST#	AF13
HDA_SDIN0	AE13
HDA_SDIN1	AC14
HDA_SDIN2	AH12
HDA_SDIN3	AD13
HDA_SDOUT	AH11
HDA_SYNC	AH10
IGNNE#	AC22
INIT#	AB19
INIT3_3V#	AC12
INTR	AH28
INTRUDER#	AF24
INTVRMEN	AA22
IRDY#	B6
LAN_RST#	AF17
LAN_RSTSYNC	E20
LAN_RXD0	E19



**Table 146. Ballout by Signal Name (Desktop Only)**

Ball Name	Ball #
LAN_RXD1	C19
LAN_RXD2	D20
LAN_TXD0	C20
LAN_TXD1	C18
LAN_TXD2	D18
LAN100_SLP	AG24
LDRQ0#	G8
LDRQ1#/GPIO23	C3
LINKALERT#	AH21
MCH_SYNC#	AE10
NMI	AC23
OC0#	AF15
OC1#/GPIO40	AH14
OC2#/GPIO41	AG14
OC3# /GPIO42	AG15
OC4#/GPIO43	AH15
OC5#/GPIO29	AE15
OC6#/GPIO30	AG13
OC7#/GPIO31	AF14
OC8#	AD14
OC9#	AG16
PAR	D9
PCICLK	B10
PCIRST#	E3
PECI	AF26
PERn1	N25
PERn2	L25
PERn3	J26
PERn4	G26
PERn5	E26
PERn6 / GLAN_RXN	C26
PERp1	N26
PERp2	L26
PERp3	J25
PERp4	G25
PERp5	E25
PERp6 / GLAN_RXP	C25
PERR#	C9
PETn1	M28

**Table 146. Ballout by Signal Name (Desktop Only)**

Ball Name	Ball #
PETn2	K28
PETn3	H28
PETn4	F28
PETn5	D28
PETn6 / GLAN_TXN	B28
PETp1	M27
PETp2	K27
PETp3	H27
PETp4	F27
PETp5	D27
PETp6/ GLAN_TXP	B27
PIRQA#	C4
PIRQB#	C5
PIROC#	A3
PIROD#	A8
PIROE#/GPIO2	D5
PIROF#/GPIO3	F10
PIROG#/GPIO4	G11
PIROH#/GPIO5	F9
PLOCK#	D11
PLTRST#	AF23
PME#	D3
PWM0	AB6
PWM1	AD6
PWM2	AB8
PWRBTN#	A1
PWROK	AE24
QRT_STATE0* / GPIO27	AD20
QRT_STATE1* / GPIO28	AD15
RCIN#	AF10
REQ0#	E8
REQ1#/GPIO50	C16
REQ2#/GPIO52	B16
REQ3#/GPIO54	A9
RI#	AG17
RSMRST#	AD22
RTCST#	AD21
RTCX1	AH26

**Table 146. Ballout by Signal Name (Desktop Only)**

Ball Name	Ball #
RTCX2	AH27
S4_STATE#/GPIO26	AH25
SATA_CLKN	AG3
SATA_CLKP	AG4
SATA0GP/GPIO21	AB11
SATA0RXP	AC4
SATA0RXN	AC5
SATA0TXN	AE4
SATA0TXP	AE3
SATA1GP/GPIO19	AD8
SATA1RXN	AF1
SATA1RXP	AF2
SATA1TXN	AH2
SATA1TXP	AH1
SATA2GP** / GPIO36	AF8
SATA2RXN**	W5
SATA2RXP**	W4
SATA2TXN**	AA3
SATA2TXP**	AA4
SATA3GP** / GPIO37	AD9
SATA3RXN**	AB1
SATA3RXP**	AB2
SATA3TXN**	AD2
SATA3TXP**	AD1
SATA4GP	AD10
SATA4RXN	Y1
SATA4RXP	Y2
SATA4TXN	U3
SATA4TXP	U4
SATA5GP	AE9
SATA5RXN	T1
SATA5RXP	T2
SATA5TXN	V2
SATA5TXP	V1
SATACLKREQ#/GPIO35	AD12
SATALED#	AB10
SATARBIAS	R1



**Table 146. Ballout by Signal Name (Desktop Only)**

Ball Name	Ball #
SATARBIAS#	R2
SCLOCK/GPIO22	AE7
SDATAOUT0/ GPIO39	AC10
SDATAOUT1/ GPIO48	AF7
SERIRQ	AG9
SERR#	E6
SLOAD/GPIO38	AH6
SLP_M#	AG22
SLP_S3#	AF22
SLP_S4#	AH23
SLP_S5#	AC17
SMBALERT#/ GPIO11	AF21
SMBCLK	AD19
SMBDATA	AB18
SMI#	AB20
SMLINK0	AE19
SMLINK1	AG21
SPI_CLK	A19
SPI_CS0#	C21
SPI_CS1#	A18
SPI_MISO	B19
SPI_MOSI	D21
SPKR	AF6
SST	AD17
STOP#	D15
STPCLK#	AB23
SUS_STAT#/LPCPD	G7
SUSCLK	E4
SYS_RESET#	AF16
TACH0/GPIO17	AC7
TACH1/GPIO1	AF5
TACH2/GPIO6	AE6
TACH3/GPIO7	AC8
THRM#	AH9
THRMTRIP#	AG28
TPO	AE22
TP1	AE25

**Table 146. Ballout by Signal Name (Desktop Only)**

Ball Name	Ball #
TP2	AD24
TP3	AD16
TP4	AE18
TP5	AH20
TP6	AG20
TRDY#	A7
USBP0N	G2
USBP0P	G3
USBP1N	H5
USBP1P	H4
USBP2N	H1
USBP2P	H2
USBP3N	J3
USBP3P	J2
USBP4N	K5
USBP4P	K4
USBP5N	K1
USBP5P	K2
USBP6N	L3
USBP6P	L2
USBP7N	M5
USBP7P	M4
USBP8N	M2
USBP8P	M1
USBP9N	N2
USBP9P	N3
USBRBIAS	E2
USBRBIAS#	E1
V_CPU_IO	AD25
V_CPU_IO	AE26
V5REF	A15
V5REF_Sus	A2
Vcc1_05	A23
Vcc1_05	B23
Vcc1_05	C23
Vcc1_05	D23
Vcc1_05	E23
Vcc1_05	F23
Vcc1_05	G22

**Table 146. Ballout by Signal Name (Desktop Only)**

Ball Name	Ball #
Vcc1_05	G23
Vcc1_05	H22
Vcc1_05	L11
Vcc1_05	L12
Vcc1_05	L14
Vcc1_05	L16
Vcc1_05	L17
Vcc1_05	L18
Vcc1_05	M11
Vcc1_05	M18
Vcc1_05	P11
Vcc1_05	P18
Vcc1_05	T11
Vcc1_05	T18
Vcc1_05	U11
Vcc1_05	U18
Vcc1_05	V11
Vcc1_05	V12
Vcc1_05	V14
Vcc1_05	V16
Vcc1_05	V17
Vcc1_05	V18
Vcc1_5_A	D1
Vcc1_5_A	L6
Vcc1_5_A	L7
Vcc1_5_A	M6
Vcc1_5_A	M7
Vcc1_5_A	W7
Vcc1_5_A	Y7
Vcc1_5_A	AA7
Vcc1_5_A	G12
Vcc1_5_A	G15
Vcc1_5_A	Y22
Vcc1_5_A	AB9
Vcc1_5_A	AB13
Vcc1_5_A	T7
Vcc1_5_A	U5
Vcc1_5_A	U6
Vcc1_5_A	V3



**Table 146. Ballout by Signal Name (Desktop Only)**

Ball Name	Ball #
Vcc1_5_A	V4
Vcc1_5_A	V5
Vcc1_5_A	W1
Vcc1_5_A	W2
Vcc1_5_A	W3
Vcc1_5_A	U7
Vcc1_5_A	V6
Vcc1_5_A	W6
Vcc1_5_A	Y6
Vcc1_5_A	AA5
Vcc1_5_A	AA6
Vcc1_5_A	AB3
Vcc1_5_A	AB4
Vcc1_5_A	AB5
Vcc1_5_A	AC1
Vcc1_5_A	AC2
Vcc1_5_A	AC3
Vcc1_5_B	J22
Vcc1_5_B	J23
Vcc1_5_B	J24
Vcc1_5_B	K22
Vcc1_5_B	K23
Vcc1_5_B	K24
Vcc1_5_B	L22
Vcc1_5_B	L23
Vcc1_5_B	L24
Vcc1_5_B	M23
Vcc1_5_B	M24
Vcc1_5_B	N22
Vcc1_5_B	N23
Vcc1_5_B	N24
Vcc1_5_B	P23
Vcc1_5_B	P24
Vcc1_5_B	P25
Vcc1_5_B	P26
Vcc1_5_B	R22
Vcc1_5_B	R23
Vcc1_5_B	R26
Vcc1_5_B	R27

**Table 146. Ballout by Signal Name (Desktop Only)**

Ball Name	Ball #
Vcc1_5_B	R28
Vcc1_5_B	T23
Vcc1_5_B	T24
Vcc1_5_B	U22
Vcc1_5_B	U23
Vcc1_5_B	U24
Vcc1_5_B	V23
Vcc1_5_B	V24
Vcc1_5_B	W22
Vcc1_5_B	W23
Vcc1_5_B	W24
Vcc1_5_B	Y23
Vcc1_5_B	Y24
Vcc1_5_B	Y25
Vcc1_5_B	Y26
Vcc1_5_B	AA26
Vcc1_5_B	AA27
Vcc1_5_B	AA28
Vcc_DMI	AE27
Vcc_DMI	AE28
Vcc3_3	A6
Vcc3_3	B4
Vcc3_3	B15
Vcc3_3	B18
Vcc3_3	C8
Vcc3_3	C10
Vcc3_3	D14
Vcc3_3	E10
Vcc3_3	F11
Vcc3_3	G14
Vcc3_3	AB7
Vcc3_3	AD7
Vcc3_3	AE12
Vcc3_3	AF11
Vcc3_3	P5
Vcc3_3	AF28
VccCL1_05	A20
VccCL1_5	A21
VccCL3_3	F20

**Table 146. Ballout by Signal Name (Desktop Only)**

Ball Name	Ball #
VccCL3_3	G20
VccDMIPLL	P28
VccGLAN1_5	A26
VccGLAN1_5	A27
VccGLAN1_5	B25
VccGLAN1_5	B26
VccGLAN3_3	A22
VccGLANPLL	A25
VccHDA	AC13
VccLAN1_05	F17
VccLAN1_05	G17
VccLAN3_3	F19
VccLAN3_3	G19
VccRTC	AG26
VccSATAPLL	AH5
VccSus1_05	AB17
VccSus1_05	J6
VccSus1_5	J7
VccSus1_5	AB15
VccSus3_3	N6
VccSus3_3	N7
VccSus3_3	P1
VccSus3_3	P2
VccSus3_3	P3
VccSus3_3	P6
VccSus3_3	P7
VccSus3_3	R3
VccSus3_3	R4
VccSus3_3	R5
VccSus3_3	R6
VccSus3_3	R7
VccSus3_3	AB16
VccSus3_3	AB21
VccSus3_3	AC20
VccSus3_3	AD18
VccSus3_3	AF19
VccSus3_3	F3
VccSusHDA	AB14
VccUSBPLL	C1



**Table 146. Ballout by Signal Name (Desktop Only)**

Ball Name	Ball #
VRMPWRGD	AC16
Vss	B22
Vss	F4
Vss	P4
Vss	AF27
Vss	AH8
Vss	A5
Vss	A24
Vss	A28
Vss	B2
Vss	B8
Vss	B11
Vss	B14
Vss	B17
Vss	B20
Vss	B24
Vss	C22
Vss	C27
Vss	C28
Vss	D2
Vss	D4
Vss	D6
Vss	D12
Vss	D16
Vss	D19
Vss	D22
Vss	D25
Vss	D26
Vss	E9
Vss	E21
Vss	E24
Vss	E27
Vss	E28
Vss	F2
Vss	F7
Vss	F15
Vss	F22
Vss	F24
Vss	F25

**Table 146. Ballout by Signal Name (Desktop Only)**

Ball Name	Ball #
Vss	F26
Vss	G1
Vss	G4
Vss	G5
Vss	G6
Vss	G10
Vss	G13
Vss	G18
Vss	G24
Vss	G27
Vss	G28
Vss	H3
Vss	H6
Vss	H7
Vss	H23
Vss	H24
Vss	H25
Vss	H26
Vss	J1
Vss	J4
Vss	J5
Vss	J27
Vss	J28
Vss	K3
Vss	K6
Vss	K7
Vss	K25
Vss	K26
Vss	L1
Vss	L4
Vss	L5
Vss	L13
Vss	L15
Vss	L27
Vss	L28
Vss	M3
Vss	M12
Vss	M13
Vss	M14

**Table 146. Ballout by Signal Name (Desktop Only)**

Ball Name	Ball #
Vss	M15
Vss	M16
Vss	M17
Vss	M22
Vss	M25
Vss	M26
Vss	N1
Vss	N4
Vss	N5
Vss	N11
Vss	N12
Vss	N13
Vss	N14
Vss	N15
Vss	N16
Vss	N17
Vss	N18
Vss	N27
Vss	N28
Vss	P12
Vss	P13
Vss	P14
Vss	P15
Vss	P16
Vss	P17
Vss	P22
Vss	P27
Vss	R11
Vss	R12
Vss	R13
Vss	R14
Vss	R15
Vss	R16
Vss	R17
Vss	R18
Vss	T3
Vss	T4
Vss	T5
Vss	T6





**Table 146. Ballout by Signal Name (Desktop Only)**

Ball Name	Ball #
Vss	T12
Vss	T13
Vss	T14
Vss	T15
Vss	T16
Vss	T17
Vss	T22
Vss	T25
Vss	T26
Vss	U1
Vss	U2
Vss	U12
Vss	U13
Vss	U14
Vss	U15
Vss	U16
Vss	U17
Vss	U27
Vss	U28
Vss	V7
Vss	V13
Vss	V15
Vss	V22
Vss	V25
Vss	V26
Vss	W27
Vss	W28
Vss	Y3
Vss	Y4
Vss	Y5
Vss	AA1
Vss	AA2
Vss	AA23
Vss	AB12
Vss	AB24
Vss	AB25
Vss	AB26
Vss	AC6
Vss	AC9

**Table 146. Ballout by Signal Name (Desktop Only)**

Ball Name	Ball #
Vss	AC15
Vss	AC18
Vss	AC21
Vss	AC27
Vss	AC28
Vss	AD3
Vss	AD4
Vss	AD5
Vss	AD11
Vss	AD26
Vss	AE1
Vss	AE2
Vss	AE5
Vss	AE8
Vss	AE14
Vss	AE17
Vss	AE20
Vss	AE23
Vss	AF3
Vss	AF4
Vss	AG1
Vss	AG2
Vss	AG5
Vss	AG11
Vss	AG25
Vss	AG27
Vss	AH3
Vss	AH4
Vss	AH13
Vss	AH16
Vss	AH19
Vss	AH22
WAKE#	AH18
WOL_EN/GPIO9	AG18



## 22.2 Ballout (Mobile Only)

Figure 20 and Figure 21 show the top view ballout for the 82801HBM ICH8M and 82801HEM ICH8M-E components. Table 147 provides the ballout, organized alphabetically by signal name.

Figure 20. Ballout (Top View–Left Side) (Mobile Only)

	1	2	3	4	5	6	7	8	9	10	11	12	13	14					
A	VSS_NCTF	VSS_NCTF	AD31	REQ0#	VSS	AD28	PERR#	Vcc3_3	AD17	PIROD#	REQ3#/GPIO54	AD10	Vcc1_05	AD12	A				
B	VSS_NCTF	VSS	PIROH#/GPIO5	Vcc3_3	PIROB#	AD15	PLOCK#	VSS	Vcc3_3	PCICLK	VSS	AD19	Vcc1_05	VSS	B				
C	VccSus3_3	PWRBTN#	VccSus3_3	FWH4/LFRAME#	PIROC#	VSS	AD22	IRDY#	TRDY#	GNT3#/GPIO55	AD16	AD20	Vcc1_05	Vcc1_05	C				
D	VccUSBPLL	VSS	SUSCLK	VSS	VSS	AD30	GNT0#	AD27	PAR	AD21	AD18	VSS	Vcc3_3	Vcc1_05	D				
E	CK_PWRGD	VSS	CLPWROK	VSS	FWHO/LAD0	LDRQ1#/GPIO23	Vcc3_3	AD29	VSS	Vcc3_3	AD24	AD26	AD25	Vcc1_05	E				
F	Vcc1_5_A	USBRBIAS#	USBRBIAS	SUS_STAT#	FWH1/LAD1	FWH3/LAD3	VSS	PIROE#/GPIO2	PIROA#	SERR#	Vcc3_3	PIROG#/GPIO4	AD23	Vcc1_05	F				
G	VSS	USBP0P	USBP0N	V5REF_Sus	CLK48	PCIRST#	PME#	FWH2/LAD2	LDRQ0#	VSS	PIROF#/GPIO3	Vcc1_5_A	VSS	Vcc1_05	G				
H	USBP2P	USBP2N	VSS	USBP1P	USBP1N	VSS	Vcc1_5_A								H				
J	VSS	USBP3P	USBP3N	VSS	VSS	VccSus1_05	VccSus1_5								J				
K	USBP5P	USBP5N	VSS	USBP4P	USBP4N	VSS	VSS								K				
L	VSS	USBP6P	USBP6N	VSS	VSS	Vcc1_5_A	Vcc1_5_A								Vcc1_05	Vcc1_05	VSS	Vcc1_05	L
M	USBP8P	USBP8N	VSS	USBP7P	USBP7N	Vcc1_5_A	Vcc1_5_A								Vcc1_05	VSS	VSS	VSS	M
N	VSS	USBP9P	USBP9N	VSS	VSS	VSS	VccSus3_3								VSS	VSS	VSS	VSS	N
P	VccSus3_3	VccSus3_3	VccSus3_3	VccSus3_3	VccSus3_3	VccSus3_3	VccSus3_3								Vcc1_05	VSS	VSS	VSS	P
R	VccSus3_3	DD9	VccSus3_3	VSS	VccSus3_3	VccSus3_3									VSS	VSS	VSS	VSS	R
T	DD3	VSS	DD8	DD10	DD5	DD7	V5REF								Vcc1_05	VSS	VSS	VSS	T
U	DD13	DD1	VSS	VSS	VSS	DD15	Vcc3_3								Vcc1_05	VSS	VSS	VSS	U
V	DD0	DD14	DD2	DD4	DD12	DD11	Vcc3_3	Vcc1_05	Vcc1_05	VSS	Vcc1_05	V							
W	Vcc3_3	VSS	DIOW#	DIOR#	DDREQ	Vcc3_3	Vcc3_3	W											
Y	IORDY	DDACK#	IDDIRQ	VSS	DCS3#	DCS1#	Vcc3_3	Y											
AA	DA1	VSS	Vcc3_3	DA0	Vcc1_5_A	Vcc1_5_A	VSS	AA											
AB	VSS	DD6	DA2	VSS	VSS	VSS	SATA_CLKN	AB											
AC	Vcc1_5_A	Vcc1_5_A	Vcc1_5_A	Vcc1_5_A	Vcc1_5_A	SATA_CLKP	Vcc1_5_A	Vcc3_3	Vcc1_5_A	Vcc1_5_A	VSS	VccHDA	THRM#	VSS	AC				
AD	VSS	Vcc3_3	VSS	VSS	VSS	VSS	Vcc1_5_A	Vcc3_3	SPKR	SDATAOUT1/GPIO48	VccSusHDA	OC6#/GPIO30	HDA_SDIN3	OC8#	AD				
AE	VSS	VSS	SATA2TXP**	SATA2TXN**	VSS	VSS	Vcc1_5_A	Vcc3_3	VSS	HDA_DOCK_EN#/GPIO33	GPIO20	VSS	HDA_SDOUT	HDA_RST#	AE				
AF	SATA2RXP**	SATA2RXN**	VSS	VSS	SATAORXP	SATAORXN	Vcc1_5_A	Vcc3_3	SLOAD/GPIO38	SATALED#	SATA2GP**/GPIO36	SERIRQ	A20GATE	VSS	AF				
AG	SATARBIAS#	SATARBIAS	SATA1RXN	SATA1RXP	VSS	VSS	Vcc1_5_A	TACHO/GPIO17	CLK14	SCLOCK/GPIO22	SATA3GP**/GPIO37	GPIO0/BMBUSY#	SATACLKREQ#/GPIO35	HDA_DOCK_RST#/GPIO34	AG				
AH	VSS_NCTF	VSS	VSS	VSS	SATAOTXN	SATAOTXP	Vcc1_5_A	VSS	TACH3/GPIO7	SCLOCK/GPIO22	CLKRUN#/GPIO32	GPIO18	VSS	RCIN#	AH				
AJ	VSS_NCTF	VSS_NCTF	SATA1TXP	SATA1TXN	VSS	VSS	Vcc1_5_A	TACH1/GPIO1	TACH2/GPIO6	VSS	SDATAOUT0/GPIO39	SATA0GP/GPIO21	MCH_SYNC#	DPRSLPVR/GPIO16	AJ				



Figure 21. Ballout (Top View–Right Side) (Mobile Only)

	15	16	17	18	19	20	21	22	23	24	25	26	27	28	29						
A	AD14	V5REF	FRAME#	AD8	AD6	AD3	AD5	VccCL1_5	VSS	VccGLANPLL	VSS	VccGLAN1_5	VccGLAN1_5	VSS_NCTF	VSS_NCTF	A					
B	Vcc3_3	AD9	VSS	Vcc3_3	REQ2#/ GPIO52	VSS	LAN_RXD1	VSS	SPI_CS0#	GLAN_CLK	VccGLAN3_3	VccGLAN1_5	VccGLAN1_5	VccGLAN1_5	VSS_NCTF	B					
C	Vcc3_3	STOP#	C/BE0#	GNT1#/ GPIO51	AD7	LAN_TXD2	LAN_RXD0	LAN_RXD1	SMLINK1	VSS	GLAN_ COMPO	VSS	VSS	PETp6 / GLAN_TXP	PETn6 / GLAN_TXN	C					
D	VSS	DEVSEL#	AD4	VSS	AD2	AD0	LAN_TXD0	LAN_ RSTSYNC	SPI_MOSI	CL_VREF0	GLAN_ COMPI	PERp6/ GLAN_RXP	PERn6/ GLAN_RXN	Vcc1_5_B	Vcc1_5_B	D					
E	C/BE1#	AD11	C/BE3#	REQ1#/ GPIO50	AD1	LAN_TXD1	VSS	SPI_CS1#	VSS	VSS	Vcc1_5_B	Vcc1_5_B	Vcc1_5_B	PETp5	PETn5	E					
F	VSS	C/BE2#	VccLAN1_05	GNT2#/ GPIO53	VccLAN3_3	VccCL3_3	SPI_MISO	CL_DATA0	CL_CLK0	Vcc1_5_B	Vcc1_5_B	PERp5	PERn5	VSS	VSS	F					
G		AD13	Vcc1_5_A	VccLAN1_05	VSS	VccLAN3_3	VccCL3_3	VccCL1_05	VSS	Vcc1_5_B	VSS	VSS	VSS	PETp4	PETn4	G					
H										Vcc1_5_B	Vcc1_5_B	VSS	PERp4	PERn4	VSS	VSS	H				
J										Vcc1_5_B	Vcc1_5_B	VSS	VSS	VSS	PETp3	PETn3	J				
K										VSS	Vcc1_5_B	Vcc1_5_B	PERp3	PERn3	VSS	VSS	K				
L	VSS	Vcc1_05	Vcc1_05	Vcc1_05										Vcc1_5_B	Vcc1_5_B	Vcc1_5_B	VSS	VSS	PETp2	PETn2	L
M	VSS	VSS	VSS	Vcc1_05										VSS	Vcc1_5_B	Vcc1_5_B	PERp2	PERn2	VSS	VSS	M
N	VSS	VSS	VSS	VSS										Vcc1_5_B	Vcc1_5_B	Vcc1_5_B	VSS	VSS	PETp1	PETn1	N
P	VSS	VSS	VSS	Vcc1_05										VSS	Vcc1_5_B	Vcc1_5_B	PERp1	PERn1	VSS	VSS	P
R	VSS	VSS	VSS	VSS											Vcc1_5_B	Vcc1_5_B	Vcc1_5_B	Vcc1_5_B	VSS	VccDMIPLL	R
T	VSS	VSS	VSS	Vcc1_05										Vcc1_5_B	Vcc1_5_B	DMI_CLKP	DMI_CLKN	Vcc1_5_B	Vcc1_5_B	Vcc1_5_B	T
U	VSS	VSS	VSS	Vcc1_05										VSS	Vcc1_5_B	Vcc1_5_B	VSS	VSS	DMI0TXP	DMI0TXN	U
V	VSS	Vcc1_05	Vcc1_05	Vcc1_05										Vcc1_5_B	Vcc1_5_B	Vcc1_5_B	DMI0RXP	DMI0RXN	VSS	VSS	V
W										Vcc1_5	VSS	Vcc1_5_B	VSS	VSS	DMI1TXP	DMI1TXN	W				
Y										DMI_ZCOMP	DMI_ IRCOMP	Vcc1_5_B	DMI1RXP	DMI1RXN	VSS	VSS	Y				
AA										TP8	STPCLK#	Vcc1_5_B	Vcc1_5_B	Vcc1_5_B	DMI2TXP	DMI2TXN	AA				
AB										VSS	VSS	DMI2RXP	DMI2RXN	Vcc1_5_B	Vcc1_5_B	Vcc1_5_B	AB				
AC		VccSus1_5	SMLINK0	VccSus3_3	GLAN_DOC K#/GPIO12	INTR	VccSus3_3	VccSus3_3	V_CPU_IO	V_CPU_IO	VSS	VSS	VSS	DMI3TXP	DMI3TXN	AC					
AD	SYS_ RESET#	GPIO28	VSS	SLP_S5#	SMBDATA	VSS	LAN100_ SLP	INTRUDER#	NMI	FERR#	VccRTC	DMI3RXP	DMI3RXN	VSS	VSS	AD					
AE	OC3#/ GPIO42	GPIO8	WAKE#	CL_CLK1	SMLINK1	STP_PCI#/ GPIO15	BATLOW#	VSS	PWROK	INIT#	VSS	DPSLP#	THRMTTRIP#	Vcc_DMI	Vcc_DMI	AE					
AF	OC4#/ GPIO43	VSS	RI#	VSS	CL_DATA1	VccSus1_05	SLP_S4#	AC_PRESENT /GPIO14	RTCRST#	RTCX2	INTVRMEN	DPRSTP#	IGNNE#	VSS	Vcc3_3	AF					
AG	OC2#/ GPIO41	OC1#/ GPIO40	OC5#/ GPIO29	STP_CPU#/ GPIO25	CLGPIO3/ GPIO9	VccSus3_3	LINKALERT#	SMBALERT#/ GPIO11	SLP_S3#	PLTRST#	RTCX1	A20M#	RSMRST#	SMI#	CLK14	AG					
AH	HDA_ SDIN2	VSS	HDA_SDIN1	OC9#	VSS	LAN_RST#	ENERGY_DE TECT/ GPIO13	VSS	CL_VREF1	VSS	/GPIO27	VSS	S4_STATE#/ GPIO26	VccSus3_3	VSS_NCTF	AH					
AJ	HDA_SYNC	HDA_ BIT_CLK	HDA_SDIN0	OC7#/ GPIO31	OC0#	VRMPWRGD	TP3	TP7	CL_RST#	SusPwrAck/ ALERT#/ GPIO10	SLP_M#	VccSATAPLL	CLGPIO0/ GPIO24	VSS_NCTF	VSS_NCTF	AJ					



**Table 147. Ballout by Signal Name (Mobile Only)**

Ball Name	Ball #
A20GATE	AF13
A20M#	AG26
AC_PRESENT/ GPIO14	AF22
AD0	D20
AD1	E19
AD10	A12
AD11	E16
AD12	A14
AD13	G16
AD14	A15
AD15	B6
AD16	C11
AD17	A9
AD18	D11
AD19	B12
AD2	D19
AD20	C12
AD21	D10
AD22	C7
AD23	F13
AD24	E11
AD25	E13
AD26	E12
AD27	D8
AD28	A6
AD29	E8
AD3	A20
AD30	D6
AD31	A3
AD4	D17
AD5	A21
AD6	A19
AD7	C19
AD8	A18
AD9	B16
BATLOW#	AE21
BMBUSY#/GPIO0	AG12
C/BE0#	C17

**Table 147. Ballout by Signal Name (Mobile Only)**

Ball Name	Ball #
C/BE1#	E15
C/BE2#	F16
C/BE3#	E17
CK_PWRGD	E1
CL_CLK0	F23
CL_CLK1	AE18
CL_DATA0	F22
CL_DATA1	AF19
CL_RST#	AJ23
CL_VREF0	D24
CL_VREF1	AH23
CLGPIO0/GPIO24	AJ27
CLK14	AG9
CLK48	G5
CLKRUN#	AH11
CLPWROK	E3
CPUPWRGD/ GPIO49	AG29
DA0	AA4
DA1	AA1
DA2	AB3
DCS1#	Y6
DCS3#	Y5
DD0	V1
DD1	U2
DD10	T4
DD11	V6
DD12	V5
DD13	U1
DD14	V2
DD15	U6
DD2	V3
DD3	T1
DD4	V4
DD5	T5
DD6	AB2
DD7	T6
DD8	T3
DD9	R2

**Table 147. Ballout by Signal Name (Mobile Only)**

Ball Name	Ball #
DDACK#	Y2
DDREQ	W5
DEVSEL#	D16
DIOR#	W4
DIOW#	W3
DMI_CLKN	T26
DMI_CLKP	T25
DMI_IRCOMP	Y24
DMI_ZCOMP	Y23
DMIORXN	V27
DMIORXP	V26
DMIOTXN	U29
DMIOTXP	U28
DMI1RXN	Y27
DMI1RXP	Y26
DMI1TXN	W29
DMI1TXP	W28
DMI2RXN	AB26
DMI2RXP	AB25
DMI2TXN	AA29
DMI2TXP	AA28
DMI3RXN	AD27
DMI3RXP	AD26
DMI3TXN	AC29
DMI3TXP	AC28
DPRSLPVR/GPIO16	AJ14
DPRSTP#	AF26
DPSLP#	AE26
Energy_DETECT/ GPIO13	AH21
FERR#	AD24
FRAME#	A17
FWHO/LAD0	E5
FWH1/LAD1	F5
FWH2/LAD2	G8
FWH3/LAD3	F6
FWH4/LFRAME#	C4
GLAN_CLK	B24
GLAN_COMP1	D25



**Table 147. Ballout by Signal Name (Mobile Only)**

Ball Name	Ball #
GLAN_COMPO	C25
GLAN_DOCK#/GPIO12	AC19
GNT0#	D7
GNT1#/GPIO51	C18
GNT2#/GPIO53	F18
GNT3#/GPIO55	C10
GPIO18	AH12
GPIO20	AE11
GPIO8	AE16
HDA_BIT_CLK	AJ16
HDA_DOCK_EN#/GPIO33	AE10
HDA_DOCK_RST#/GPIO34	AG14
HDA_RST#	AE14
HDA_SDIN0	AJ17
HDA_SDIN1	AH17
HDA_SDIN2	AH15
HDA_SDIN3	AD13
HDA_SDOU	AE13
HDA_SYNC	AJ15
IDEIRQ	Y3
IGNNE#	AF27
INIT#	AE24
INTR	AC20
INTRUDER#	AD22
INTVRMEN	AF25
IORDY	Y1
IRDY#	C8
LAN_RST#	AH20
LAN_RSTSYNC	D22
LAN_RXD0	C21
LAN_RXD1	B21
LAN_RXD2	C22
LAN_TXD0	D21
LAN_TXD1	E20
LAN_TXD2	C20
LAN100_SLP	AD21
LDRQ0#	G9

**Table 147. Ballout by Signal Name (Mobile Only)**

Ball Name	Ball #
LDRQ1#/GPIO23	E6
LINKALERT#	AG21
MCH_SYNC#	AJ13
NMI	AD23
OC0#	AJ19
OC1#/GPIO40	AG16
OC2#/GPIO41	AG15
OC3#/GPIO42	AE15
OC4#/GPIO43	AF15
OC5#/GPIO29	AG17
OC6#/GPIO30	AD12
OC7#/GPIO31	AJ18
OC8#	AD14
OC9#	AH18
PAR	D9
PCICLK	B10
PCIRST#	G6
PERn1	P27
PERn2	M27
PERn3	K27
PERn4	H27
PERn5	F27
PERn6/GLAN_RXN	D27
PERp1	P26
PERp2	M26
PERp3	K26
PERp4	H26
PERp5	F26
PERp6/GLAN_RXP	D26
PERR#	A7
PETn1	N29
PETn2	L29
PETn3	J29
PETn4	G29
PETn5	E29
PETn6/GLAN_TXN	C29
PETp1	N28
PETp2	L28
PETp3	J28

**Table 147. Ballout by Signal Name (Mobile Only)**

Ball Name	Ball #
PETp4	G28
PETp5	E28
PETp6/GLAN_TXP	C28
PIROA#	F9
PIROB#	B5
PIROC#	C5
PIROD#	A10
PIROE#/GPIO2	F8
PIROF#/GPIO3	G11
PIROG#/GPIO4	F12
PIROH#/GPIO5	B3
PLOCK#	B7
PLTRST#	AG24
PME#	G7
PWRBTN#	C2
PWROK	AE23
GPIO27	AH25
GPIO28	AD16
RCIN#	AH14
REQ0#	A4
REQ1#/GPIO50	E18
REQ2#/GPIO52	B19
REQ3#/GPIO54	A11
RI#	AF17
RSMRST#	AG27
RTCST#	AF23
RTCX1	AG25
RTCX2	AF24
S4_STATE#/GPIO26	AH27
SATA_CLKN	AB7
SATA_CLKP	AC6
SATA0GP/GPIO21	AJ12
SATA0RXN	AF6
SATA0RXP	AF5
SATA0TXN	AH5
SATA0TXP	AH6
SATA1GP/GPIO19	AJ10
SATA1RXN	AG3



**Table 147. Ballout by Signal Name (Mobile Only)**

Ball Name	Ball #
SATA1RXP	AG4
SATA1TXN	AJ4
SATA1TXP	AJ3
SATA2GP**/ GPIO36	AF11
SATA2RXN**	AF2
SATA2RXP**	AF1
SATA2TXN**	AE4
SATA2TXP**	AE3
GPIO37	AG11
SATACLKREQ#/ GPIO35	AG13
SATALED#	AF10
SATARBIAS	AG2
SATARBIAS#	AG1
SCLOCK/GPIO22	AG10
SDATAOUT0/ GPIO39	AJ11
SDATAOUT1/ GPIO48	AD10
SERIRQ	AF12
SERR#	F10
SLOAD/GPIO38	AF9
SLP_M#	AJ25
SLP_S3#	AG23
SLP_S4#	AF21
SLP_S5#	AD18
SMBALERT#/ GPIO11	AG22
SMBCLK	AJ26
SMBDATA	AD19
SMI#	AG28
SMLINK0	AC17
SMLINK1	AE19
SPI_CLK	C23
SPI_CS0#	B23
SPI_CS1#	E22
SPI_MISO	F21
SPI_MOSI	D23
SPKR	AD9
STOP#	C16

**Table 147. Ballout by Signal Name (Mobile Only)**

Ball Name	Ball #
STP_CPU#	AG18
STP_PCI#	AE20
STPCLK#	AA24
SusPwrAck/ ALERT#/GPIO10	AJ24
SUS_STAT#/ LPCPD#	F4
SUSCLK	D3
SYS_RESET#	AD15
GPIO17	AG8
GPIO1	AJ8
GPIO6	AJ9
GPIO7	AH9
THRM#	AC13
THRMTRIP#	AE27
TP3	AJ21
TP7	AJ22
TP8	AA23
TRDY#	C9
USBP0N	G3
USBPOP	G2
USBP1N	H5
USBP1P	H4
USBP2N	H2
USBP2P	H1
USBP3N	J3
USBP3P	J2
USBP4N	K5
USBP4P	K4
USBP5N	K2
USBP5P	K1
USBP6N	L3
USBP6P	L2
USBP7N	M5
USBP7P	M4
USBP8N	M2
USBP8P	M1
USBP9N	N3
USBP9P	N2
USBRBIAS	F3

**Table 147. Ballout by Signal Name (Mobile Only)**

Ball Name	Ball #
USBRBIAS#	F2
V_CPU_IO	AC23
V_CPU_IO	AC24
V5REF	T7
V5REF	A16
V5REF_Sus	G4
Vcc_DMI	AE28
Vcc_DMI	AE29
Vcc1_05	L11
Vcc1_05	M11
Vcc1_05	P11
Vcc1_05	T11
Vcc1_05	U11
Vcc1_05	V11
Vcc1_05	G14
Vcc1_05	L12
Vcc1_05	V12
Vcc1_05	A13
Vcc1_05	B13
Vcc1_05	C13
Vcc1_05	C14
Vcc1_05	D14
Vcc1_05	E14
Vcc1_05	F14
Vcc1_05	L14
Vcc1_05	V14
Vcc1_05	L16
Vcc1_05	V16
Vcc1_05	L17
Vcc1_05	V17
Vcc1_05	L18
Vcc1_05	M18
Vcc1_05	P18
Vcc1_05	T18
Vcc1_05	U18
Vcc1_05	V18
Vcc1_5_A	W23
Vcc1_5_A	AC7
Vcc1_5_A	AE7



**Table 147. Ballout by Signal Name (Mobile Only)**

Ball Name	Ball #
Vcc1_5_A	AF7
Vcc1_5_A	AG7
Vcc1_5_A	AH7
Vcc1_5_A	AJ7
Vcc1_5_A	AC1
Vcc1_5_A	AC2
Vcc1_5_A	AC3
Vcc1_5_A	AC9
Vcc1_5_A	AC10
Vcc1_5_A	AA5
Vcc1_5_A	AA6
Vcc1_5_A	G12
Vcc1_5_A	G17
Vcc1_5_A	AD7
Vcc1_5_A	F1
Vcc1_5_A	L6
Vcc1_5_A	M6
Vcc1_5_A	L7
Vcc1_5_A	M7
Vcc1_5_A	AC4
Vcc1_5_A	AC5
Vcc1_5_A	H7
Vcc1_5_B	H23
Vcc1_5_B	J23
Vcc1_5_B	L23
Vcc1_5_B	N23
Vcc1_5_B	T23
Vcc1_5_B	V23
Vcc1_5_B	F24
Vcc1_5_B	G24
Vcc1_5_B	H24
Vcc1_5_B	J24
Vcc1_5_B	K24
Vcc1_5_B	L24
Vcc1_5_B	M24
Vcc1_5_B	N24
Vcc1_5_B	P24
Vcc1_5_B	R24
Vcc1_5_B	T24

**Table 147. Ballout by Signal Name (Mobile Only)**

Ball Name	Ball #
Vcc1_5_B	U24
Vcc1_5_B	V24
Vcc1_5_B	E25
Vcc1_5_B	F25
Vcc1_5_B	K25
Vcc1_5_B	L25
Vcc1_5_B	M25
Vcc1_5_B	N25
Vcc1_5_B	P25
Vcc1_5_B	R25
Vcc1_5_B	U25
Vcc1_5_B	V25
Vcc1_5_B	W25
Vcc1_5_B	Y25
Vcc1_5_B	AA25
Vcc1_5_B	E26
Vcc1_5_B	R26
Vcc1_5_B	AA26
Vcc1_5_B	E27
Vcc1_5_B	R27
Vcc1_5_B	T27
Vcc1_5_B	AA27
Vcc1_5_B	AB27
Vcc1_5_B	D28
Vcc1_5_B	T28
Vcc1_5_B	AB28
Vcc1_5_B	D29
Vcc1_5_B	T29
Vcc1_5_B	AB29
Vcc3_3	W6
Vcc3_3	V7
Vcc3_3	D5
Vcc3_3	AF29
Vcc3_3	AD2
Vcc3_3	AD8
Vcc3_3	AE8
Vcc3_3	AF8
Vcc3_3	W1
Vcc3_3	AA3

**Table 147. Ballout by Signal Name (Mobile Only)**

Ball Name	Ball #
Vcc3_3	W7
Vcc3_3	Y7
Vcc3_3	B4
Vcc3_3	E7
Vcc3_3	A8
Vcc3_3	B9
Vcc3_3	E10
Vcc3_3	F11
Vcc3_3	D13
Vcc3_3	B15
Vcc3_3	B18
Vcc3_3	AC8
Vcc3_3	U7
Vcc3_3	C15
VccCL1_05	G22
VccCL1_5	A22
VccCL3_3	F20
VccCL3_3	G21
VccDMIPLL	R29
VccGLAN1_5	B28
VccGLAN1_5	A26
VccGLAN1_5	B26
VccGLAN1_5	A27
VccGLAN1_5	B27
VccGLAN3_3	B25
VccGLANPLL	A24
VccHDA	AC12
VccLAN1_05	F17
VccLAN1_05	G18
VccLAN3_3	F19
VccLAN3_3	G20
VccRTC	AD25
VccSATAPLL	AJ6
VccSus1_05	J6
VccSus1_05	AF20
VccSus1_5	AC16
VccSus1_5	J7
VccSus3_3	AC18
VccSus3_3	AG20



**Table 147. Ballout by Signal Name (Mobile Only)**

Ball Name	Ball #
VccSus3_3	AC21
VccSus3_3	AC22
VccSus3_3	AH28
VccSus3_3	C1
VccSus3_3	P1
VccSus3_3	R1
VccSus3_3	P2
VccSus3_3	P3
VccSus3_3	R3
VccSus3_3	P4
VccSus3_3	P5
VccSus3_3	R5
VccSus3_3	P6
VccSus3_3	R6
VccSus3_3	N7
VccSus3_3	P7
VCCSUS3_3	C3
VccSusHDA	AD11
VccUSBPLL	D1
VRMPWRGD	AJ20
VSS	E23
VSS	D18
VSS	A5
VSS	B20
VSS	AB4
VSS	D15
VSS	AE25
VSS	AH8
VSS	AH10
VSS	B22
VSS	C24
VSS	AC14
VSS	AE22
VSS	AH2
VSS	AE9
VSS	E4
VSS	AH13
VSS	E2
VSS	AD6

**Table 147. Ballout by Signal Name (Mobile Only)**

Ball Name	Ball #
VSS	AD3
VSS	AD4
VSS	B14
VSS	C26
VSS	C27
VSS	U3
VSS	U4
VSS	U5
VSS	AC11
VSS	H6
VSS	G1
VSS	J1
VSS	L1
VSS	N1
VSS	AB1
VSS	AE1
VSS	B2
VSS	D2
VSS	T2
VSS	AA2
VSS	AE2
VSS	H3
VSS	K3
VSS	M3
VSS	AF3
VSS	AH3
VSS	D4
VSS	J4
VSS	L4
VSS	N4
VSS	R4
VSS	AF4
VSS	AH4
VSS	J5
VSS	L5
VSS	N5
VSS	AB5
VSS	AD5
VSS	AE5

**Table 147. Ballout by Signal Name (Mobile Only)**

Ball Name	Ball #
VSS	AG5
VSS	AJ5
VSS	C6
VSS	K6
VSS	N6
VSS	AB6
VSS	AE6
VSS	AG6
VSS	F7
VSS	K7
VSS	AA7
VSS	B8
VSS	E9
VSS	G10
VSS	B11
VSS	N11
VSS	R11
VSS	D12
VSS	M12
VSS	N12
VSS	P12
VSS	R12
VSS	T12
VSS	U12
VSS	AE12
VSS	G13
VSS	L13
VSS	M13
VSS	N13
VSS	P13
VSS	R13
VSS	T13
VSS	U13
VSS	V13
VSS	M14
VSS	N14
VSS	P14
VSS	R14
VSS	T14





**Table 147. Ballout by Signal Name (Mobile Only)**

Ball Name	Ball #
VSS	U14
VSS	AF14
VSS	F15
VSS	L15
VSS	M15
VSS	N15
VSS	P15
VSS	R15
VSS	T15
VSS	U15
VSS	V15
VSS	M16
VSS	N16
VSS	P16
VSS	R16
VSS	T16
VSS	U16
VSS	AF16
VSS	AH16
VSS	B17
VSS	M17
VSS	N17
VSS	P17
VSS	R17
VSS	T17
VSS	U17
VSS	AD17
VSS	N18
VSS	R18
VSS	AF18
VSS	G19
VSS	AD20
VSS	E21
VSS	AH22
VSS	A23
VSS	G23
VSS	K23
VSS	M23
VSS	P23

**Table 147. Ballout by Signal Name (Mobile Only)**

Ball Name	Ball #
VSS	U23
VSS	AB23
VSS	E24
VSS	AB24
VSS	AH24
VSS	G25
VSS	H25
VSS	J25
VSS	AC25
VSS	G26
VSS	J26
VSS	L26
VSS	N26
VSS	U26
VSS	AC26
VSS	AH26
VSS	G27
VSS	J27
VSS	L27
VSS	N27
VSS	U27
VSS	AC27
VSS	F28
VSS	H28
VSS	K28
VSS	M28
VSS	P28
VSS	R28
VSS	V28
VSS	AD28
VSS	F29
VSS	H29
VSS	K29
VSS	M29
VSS	P29
VSS	V29
VSS	AD29
VSS	W2
VSS	Y4

**Table 147. Ballout by Signal Name (Mobile Only)**

Ball Name	Ball #
VSS	W24
VSS	W26
VSS	W27
VSS	Y28
VSS	Y29
VSS	AF28
VSS	AD1
VSS	A25
VSS_NCTF	A1
VSS_NCTF	A2
VSS_NCTF	AH1
VSS_NCTF	B1
VSS_NCTF	AJ1
VSS_NCTF	AJ2
VSS_NCTF	A28
VSS_NCTF	AJ28
VSS_NCTF	A29
VSS_NCTF	B29
VSS_NCTF	AH29
VSS_NCTF	AJ29
WAKE#	AE17
WOL_EN/GPIO9	AG19

§ §





## 23 Electrical Characteristics

This chapter contains the DC and AC characteristics for the ICH8. AC timing diagrams are included.

### 23.1 Thermal Specifications

Refer to the *Intel® I/O Controller Hub (ICH8) Thermal Design Guidelines* document for ICH8 thermal information.

### 23.2 Absolute Maximum Ratings<sup>4</sup>

Table 148. Intel® ICH8 Absolute Maximum Ratings

Parameter	Maximum Limits
Voltage on any 3.3 V Pin with respect to Ground	-0.5 to Vcc3_3 + 0.5 V
Voltage on any 5 V Tolerant Pin with respect to Ground (V5REF = 5 V)	-0.5 to V5REF + 0.5 V
1.05 V Supply Voltage with respect to VSS	-0.5 to 2.1 V
1.25 V Supply Voltage with respect to VSS	-0.5V to 2.1V
1.5 V Supply Voltage with respect to VSS	-0.5 to 2.1 V
3.3 V Supply Voltage with respect to VSS	-0.5 to 4.6 V
5.0 V Supply Voltage with respect to VSS	-0.5 to 5.5 V
V_CPU_IO Supply Voltage with respect to VSS	-0.5 to 2.1 V



## 23.3 DC Characteristics

Table 149. DC Current Characteristics (Desktop Only)

Power Plane	Maximum Power Consumption			
	S0	S3	S4/S5	G3
V5Ref	1 mA	NA	NA	NA
V5RefSus	1 mA	1 mA	1 mA	NA
Vcc3_3	278 mA	NA	NA	NA
VccSus3_3	177 mA	44 mA	44 mA	NA
VccHDA <sup>5</sup>	32 mA	NA	NA	NA
VccSusHDA <sup>5</sup>	32 mA	1 mA	1 mA	NA
VccGLAN3_3	1 mA	NA	NA	NA
VccGLAN1_5	80 mA	NA	NA	NA
VccLAN3_3	18 mA	50 mA	50 mA	NA
VccLAN1_05 <sup>1,4</sup>	Powered by Vcc1_05 in S0	Powered by VccLAN3_3 in S3	Powered by VccLAN3_3 in S4/S5	NA
VccCL3_3	18 mA	64 mA	64 mA	NA
VccCL1_5 <sup>1</sup>	Powered by Vcc1_5_A in S0	Powered by VccCL3_3 in S3	Powered by VccCL3_3 in S4/S5	NA
VccCL1_05 <sup>1</sup>	Powered by Vcc1_05 in S0	Powered by VccCL3_3 in S3	Powered by VccCL3_3 in S4/S5	NA
Vcc1_5_A <sup>7</sup>	1.56 A	NA	NA	NA
Vcc1_5_B	657 mA	NA	NA	NA
VccSus1_5 <sup>1</sup>	Powered by Vcc1_5_A in S0	Powered by VccSus3_3 in S3	Powered by VccSus3_3 in S4/S5	NA
Vcc1_05	1.13 A	NA	NA	NA
VccSus1_05 <sup>1</sup>	Powered by Vcc1_05 in S0	Powered by VccSus3_3 in S3	Powered by VccSus3_3 in S4/S5	NA
VccRTC <sup>2,3</sup>	NA	NA	NA	6 uA
VccDMI <sup>6</sup>	50 mA	NA	NA	NA
V_CPU_IO	1 mA	NA	NA	NA
VccGLANPLL	23 mA	NA	NA	NA
VccUSBPLL	10 mA	NA	NA	NA
VccDMIPLL	23 mA	NA	NA	NA
VccSATAPLL	47 mA	NA	NA	NA

**NOTES:**

- Internal voltage regulators should power these wells inside the Intel® ICH8, and the current for these rails are accounted for in the sourcing voltage rail current requirements.
- Only the G3 state of this rail is shown to provide an estimate of battery life.
- Icc (RTC) data is taken with VccRTC at 3.0V while the system is in a mechanical off (G3) state at room temperature.
- The current for this rail in S3 and S4/S5 assumes that the integrated LAN is running at 10/100.
- The current for this rail was measured with VccHDA set to 3.3 V
- The current for this rail was measured with VccDMI set to 1.25 V
- System configuration for these measurements included 6 SATA Gen. 2 Devices



Table 150. DC Current Characteristics (Mobile Only)

Power Plane	Maximum Power Consumption				
	Symbol	S0	S3	S4/S5	G3
V5Ref	1 mA	NA	NA	NA	NA
V5RefSus	1 mA	1 mA	1 mA	1 mA	NA
Vcc3_3	442 mA	NA	NA	NA	NA
VccSus3_3	177 mA	44 mA	44 mA	44 mA	NA
VccHDA <sup>5</sup>	32 mA	NA	NA	NA	NA
VccSusHDA <sup>5</sup>	11 mA	1 mA	1 mA	1 mA	NA
VccGLAN3_3	1 mA	NA	NA	NA	NA
VccGLAN1_5	80 mA	NA	NA	NA	NA
VccLAN3_3	19 mA	51 mA	51 mA	51 mA	NA
VccLAN1_05 <sup>1,4</sup>	Powered by Vcc1_05	Powered by VccLAN3_3	Powered by VccLAN3_3	Powered by VccLAN3_3	NA
VccCL3_3	19 mA	63 mA	63 mA	63 mA	NA
VccCL1_5 <sup>1</sup>	Powered by Vcc1_5_A	Powered by VccCL3_3	Powered by VccCL3_3	Powered by VccCL3_3	NA
VccCL1_05 <sup>1</sup>	Powered by Vcc1_05	Powered by VccCL3_3	Powered by VccCL3_3	Powered by VccCL3_3	NA
Vcc1_5_A	1.08 A	NA	NA	NA	NA
Vcc1_5_B	657 mA	NA	NA	NA	NA
VccSus1_5 <sup>1</sup>	Powered by Vcc1_5_A	Powered by VccSus3_3	Powered by VccSus3_3	Powered by VccSus3_3	NA
Vcc1_05	1.13 A	NA	NA	NA	NA
VccSus1_05 <sup>1</sup>	Powered by Vcc1_05	Powered by VccSus3_3	Powered by VccSus3_3	Powered by VccSus3_3	NA
VccRTC <sup>2,3</sup>	NA	NA	NA	NA	6 uA
VccDMI <sup>6</sup>	50 mA	NA	NA	NA	NA
V_CPU_IO	1 mA	NA	NA	NA	NA
VccGLANPLL	23 mA	NA	NA	NA	NA
VccUSBPLL	10 mA	NA	NA	NA	NA
VccDMIPLL	23 mA	NA	NA	NA	NA
VccSATAPLL	47 mA	NA	NA	NA	NA

- NOTES:
1. Internal voltage regulators should power these wells inside the Intel® ICH8M.
  2. Only the G3 state of this rail is shown to provide an estimate of battery life.
  3. Icc (RTC) data is taken with VccRTC at 3.0 V while the system is in a mechanical off (G3) state at room temperature.
  4. The current for this rail in S3 and S4/S5 assumes that the integrated LAN is running at 10/100.
  5. The current for this rail was measured with VccHDA and VccSusHDA set to 1.5 V
  6. The current for this rail was measured with VccDMI set to 1.25 V



Table 151 to Table 155 should be considered the functional operating range.

**Table 151. DC Characteristic Input Signal Association (Sheet 1 of 2)**

Symbol	Associated Signals
V <sub>IH1</sub> /V <sub>IL1</sub> (5V Tolerant)	<b>PCI Signals:</b> AD[31:0], C/BE[3:0]#, DEVSEL#, FRAME#, IRDY#, PAR, PERR#, PLOCK#, REQ0#, REQ[3:1]#/GPIO[54, 52, 50], SERR#, STOP#, TRDY# <b>Interrupt Signals:</b> PIRQ[D:A]#, PIRQ[H:E]#/GPIO[5:2]
V <sub>IH2</sub> /V <sub>IL2</sub>	<b>Gigabit LAN Connect Signals:</b> GLAN_RX[p,n]
V <sub>IH3</sub> /V <sub>IL3</sub>	<b>Clock Signals:</b> CLK48 <b>Power Management Signals:</b> MCH_SYNC#, THRM#, VRMPWRGD, LAN_RST#, CLPRWOK Mobile only: BMBUSY#/GPIO0, CLKRUN# <b>SATA Signals:</b> Desktop: SATAGP[5:4], SATAGP[3:0]/GPIO[37,36,19,21], SATACLKREQ#/GPIO[35] Mobile: SATAGP[2,0]/GPIO[36,21], SATACLKREQ#/GPIO[35] <b>Intel® High Definition Audio Signals:</b> HDA_DOCK_EN#/GPIO33 (Mobile Only) <b>Interrupt Signals:</b> SERIRQ <b>Processor Signals:</b> RCIN#, A20GATE <b>USB Signals:</b> OC[9:8]#, OC[7:5]#/GPIO[31:29]#, OC[4:1]#/GPIO[43:40], OC[0]# <b>GPIO Signals:</b> Desktop: GPIO[55,53,51,48,39,38,33,32,22,20,18,17,16,7,6,1,0] Mobile: GPIO49/CPUPWRGD, GPIO[55,53,51,48,39,38,32,22,20,18,17,16,7,6,1] <b>Strap Signals:</b> SPKR, SATALED# (Strap purposes only)
V <sub>IH4</sub> /V <sub>IL4</sub>	<b>Clock Signals:</b> CLK14, PCICLK <b>LPC/Firmware Hub Signals:</b> LAD[3:0]/FWH[3:0], LDRQ0#, LDRQ1#/GPIO23 <b>PCI Signals:</b> PME# <b>SPI Signals:</b> SPI_CS[1:0]#, SPI_MISO
V <sub>IH5</sub> /V <sub>IL5</sub>	<b>SMBus Signals:</b> SMBCLK, SMBDATA, SMBALERT#/GPIO11 <b>System Management Signals:</b> SMLINK[1:0], LINKALERT#
V <sub>IH6</sub> /V <sub>IL6</sub>	<b>LAN Signals:</b> GLAN_CLK, LAN_RXD[2:0]
V <sub>IH7</sub> /V <sub>IL7</sub>	<b>Processor Signals:</b> FERR#, THRMTRIP#, CPUPWRGD/GPIO49
V <sub>IMIN8</sub> /V <sub>IMAX8</sub>	<b>PCI Express* Data RX Signals:</b> PER[p,n][6:1]
V <sub>IH9</sub> /V <sub>IL9</sub>	<b>Real Time Clock Signals:</b> RTCX1
V <sub>IMIN10</sub> /V <sub>IMAX10</sub>	<b>SATA Signals:</b> Desktop: SATA[5:0]RX[P,N] Mobile: SATA[2:0]RX[P,N]
V <sub>IH11</sub> /V <sub>IL11</sub>	<b>Intel® High Definition Audio Signals:</b> HDA_SDIN[3:0], HDA_DOCK_RST#/GPIO34 (Mobile Only) <b>Strap Signals:</b> HDA_SDOOUT, HDA_SYNC (Strap purposes only) <b>GPIO Signals:</b> GPIO34 (Desktop Only)  <b>NOTE:</b> See V <sub>IL_HDA</sub> /V <sub>IH_HDA</sub> for High Definition Audio Low Voltage Mode
V <sub>IH12</sub> /V <sub>IL12</sub> / V <sub>cross(abs)</sub>	<b>Clock Signals:</b> DMI_CLKN, DMI_CLKP, SATA_CLKN, SATA_CLKP
V <sub>IH13</sub> /V <sub>IL13</sub>	<b>Power Management Signals:</b> Desktop: PWRBTN#, RI#, SYS_RESET#, WAKE# Mobile: BATLOW#, PWRBTN#, RI#, SYS_RESET#, WAKE# <b>System Management Signal:</b> ALERT#/GPIO10, MEM_LED/GPIO24, NETDETECT/GPIO14, WOL_EN/GPIO9 <b>Intel Quick Resume Technology Signals (ICH8DH Only):</b> QRT_STATE[1:0]/GPIO[28:27] <b>GPIO Signals:</b> GPIO[26:24, 15:12, 10:8] Other Signals: TPO



Table 151. DC Characteristic Input Signal Association (Sheet 2 of 2)

Symbol	Associated Signals
$V_{IH14}/V_{IL14}$	<b>Power Management Signals:</b> PWROK, RSMRST#, RTCRST# <b>System Management Signals:</b> INTRUDER# <b>Other Signals:</b> INTVRMEN, LAN100_SLP
$V_{IH15}/V_{IL15}$ (5 V Tolerant) (Mobile Only)	<b>Interrupt Signal:</b> IDEIRQ
$V_{IH16}/V_{IL1}$ (Desktop only)	<b>Intel® Quiet System Technology:</b> TACH[3:0]/GPIO[17,7,6,1]
$V_{IH17}/V_{IL17}$	<b>Controller Link:</b> CL_CLK0, CL_DATA0 Mobile Only: CL_CLK1, CL_DATA1
$V_{+}/V_{-}/V_{HYS}/$ $V_{THRAVG}/V_{RING}$ (5 V Tolerant) (Mobile Only)	<b>IDE Signals:</b> DD[15:0], DDREQ, IORDY  For Ultra DMA Mode 4 and lower these signals follow the DC characteristics for $V_{IH15}/V_{IL15}$
$V_{DI} / V_{CM} / V_{SE}$ (5 V Tolerant)	<b>USB Signals:</b> USBP[9:0][P,N] (Low-speed and Full-speed)
$V_{HSSQ} / V_{HSDSC} /$ $V_{HSCM}$ (5 V Tolerant)	<b>USB Signals:</b> USBP[9:0][P,N] (in High-speed Mode)
$V_{IH\_HDA} / V_{IL\_HDA}$	<b>Intel® High Definition Audio Signals:</b> HDA_SDIN[3:0], HDA_DOCK_RST#/GPIO34 (Mobile only) <b>Strap Signals:</b> HDA_SDOOUT, HDA_SYNC (Strap purposes only) <b>NOTE:</b> Only applies when running in Low Voltage Mode (1.5 V)
$V_{IH\_SST}/V_{IL\_SST}$	<b>SST signal:</b> SST
$V_{IH\_PECI}/V_{IL\_PECI}$	<b>PECI signal:</b> PECI (Desktop Only)

Table 152. DC Input Characteristics (Sheet 1 of 3)

Symbol	Parameter	Min	Max	Unit	Notes
$V_{IL1}$	Input Low Voltage	-0.5	0.3(Vcc3_3)	V	
$V_{IH1}$	Input High Voltage	0.5(Vcc3_3)	V5REF + 0.5	V	
$V_{IL2}$	Minimum Input Voltage	200		mVdiff p-p	5
$V_{IH2}$	Maximum Input Voltage		1350	mVdiff p-p	5
$V_{IL3}$	Input Low Voltage	-0.5	0.8	V	
$V_{IH3}$	Input High Voltage	2.0	Vcc3_3 + 0.5	V	
$V_{IL4}$	Input Low Voltage	-0.5	0.3(Vcc3_3)	V	
$V_{IH4}$	Input High Voltage	0.5(Vcc3_3)	Vcc3_3 + 0.5	V	
$V_{IL5}$	Input Low Voltage	-0.5	0.8	V	
$V_{IH5}$	Input High Voltage	2.1	VccSus3_3 + 0.5	V	
$V_{IL6}$	Input Low Voltage	-0.5	0.3(Vcc3_3)	V	
$V_{IH6}$	Input High Voltage	0.6(Vcc3_3)	Vcc3_3 + 0.5	V	



Table 152. DC Input Characteristics (Sheet 2 of 3)

Symbol	Parameter	Min	Max	Unit	Notes
V <sub>IL7</sub>	Input Low Voltage	-0.5	0.58(V <sub>CPU_IO</sub> )	V	
V <sub>IH7</sub>	Input High Voltage	0.73(V <sub>CPU_IO</sub> )	V <sub>CPU_IO</sub> + 0.5	V	
V <sub>IMIN8</sub>	Minimum Input Voltage	175		mVdiff p-p	4
V <sub>IMAX8</sub>	Maximum Input Voltage		1200	mVdiff p-p	4
V <sub>IL9</sub>	Input Low Voltage	-0.5	0.10	V	
V <sub>IH9</sub>	Input High Voltage	0.40	1.2	V	
V <sub>IMIN10-GEN1I</sub>	Minimum Input Voltage - 1.5 Gb/s internal SATA	325		mVdiff p-p	6
V <sub>IMAX10-GEN1I</sub>	Maximum Input Voltage - 1.5 Gb/s internal SATA		600	mVdiff p-p	6
V <sub>IMIN10-GEN1M</sub>	Minimum Input Voltage - 3.0 Gb/s eSATA	240		mVdiff p-p	6
V <sub>IMAX10-GEN1M</sub>	Maximum Input Voltage - 3.0 Gb/s eSATA		600	mVdiff p-p	6
V <sub>IMIN10-GEN2I</sub>	Minimum Input Voltage - 1.5 Gb/s internal SATA	275		mVdiff p-p	6
V <sub>IMAX10-GEN2I</sub>	Maximum Input Voltage - 1.5 Gb/s internal SATA		750	mVdiff p-p	6
V <sub>IMIN10-GEN2M</sub>	Minimum Input Voltage - 3.0 Gb/s eSATA	240		mVdiff p-p	6
V <sub>IMAX10-GEN2M</sub>	Maximum Input Voltage - 3.0 Gb/s eSATA		750	mVdiff p-p	6
V <sub>IL11</sub>	Input Low Voltage	-0.5	0.35(V <sub>cc3_3</sub> )	V	
V <sub>IH11</sub>	Input High Voltage	0.65(V <sub>cc3_3</sub> )	V <sub>cc3_3</sub> + 0.5	V	
V <sub>IL12</sub>	Input Low Voltage	-0.150	0.150	V	
V <sub>IH12</sub>	Input High Voltage	0.660	0.850	V	
V <sub>IL13</sub>	Input Low Voltage	-0.5	0.8	V	
V <sub>IH13</sub>	Input High Voltage	2.0	V <sub>ccSus3_3</sub> + 0.5	V	
V <sub>IL14</sub>	Input Low Voltage	-0.5	0.78	V	
V <sub>IH14</sub>	Input High Voltage	2.0	V <sub>ccRTC</sub> + 0.5	V	7
V <sub>IL15</sub>	Input Low Voltage	-0.5	0.8	V	
V <sub>IH15</sub>	Input High Voltage	2.0	V <sub>5REF</sub> + 0.5	V	
V <sub>IL16</sub>	Input Low Voltage		0.3(V <sub>cc3_3</sub> )		
V <sub>IH16</sub>	Input High Voltage	0.6(V <sub>cc3_3</sub> )			
V <sub>IL17</sub>	Input Low Voltage	-0.3	(CL_VREF - 0.085)	V	
V <sub>IH17</sub>	Input High Voltage	(CL_VREF + 0.085)	1.2	V	
V <sub>cross(abs)</sub>	Absolute Crossing Point	0.250	0.550	V	
V <sub>+</sub>	Low to high input threshold	1.5	2.0	V	9
V <sub>-</sub>	High to low input threshold	1.0	1.5	V	9





Table 152. DC Input Characteristics (Sheet 3 of 3)

Symbol	Parameter	Min	Max	Unit	Notes
$V_{HYS}$	Difference between input thresholds: (V+current value) – (V– current value)	320		mV	9
$V_{THRAVG}$	Average of thresholds: ((V+current value) + (V– current value))/2	1.3	1.7	V	9
$V_{RING}$	AC Voltage at recipient connector	–1	6	V	9,10
$V_{DI}$	Differential Input Sensitivity	0.2		V	1,3
$V_{CM}$	Differential Common Mode Range	0.8	2.5	V	2,3
$V_{SE}$	Single-Ended Receiver Threshold	0.8	2.0	V	3
$V_{HSSQ}$	HS Squelch Detection Threshold	100	150	mV	3
$V_{HSDSC}$	HS Disconnect Detection Threshold	525	625	mV	3
$V_{HSCM}$	HS Data Signaling Common Mode Voltage Range	–50	500	mV	3
$V_{IL\_HDA}$	Input Low Voltage		0.4(V <sub>CC\_HDA</sub> )	V	
$V_{IH\_HDA}$	Input High Voltage	0.6(V <sub>CC\_HDA</sub> )		V	
$V_{IL\_SST}$	Input Low Voltage	–0.5	0.4	V	
$V_{IH\_SST}$	Input High Voltage	1.1	V <sub>CC</sub> + 0.5	V	
$V_{IL\_PECI}$ (Desktop Only)	Input Low Voltage	–0.5	0.275(V <sub>CPU\_IO</sub> )	V	
$V_{IH\_PECI}$ (Desktop Only)	Input High Voltage	0.725(V <sub>CPU\_IO</sub> )	V <sub>CPU\_IO</sub> + 0.5	V	

**NOTES:**

- $V_{DI} = | \text{USBPx[P]} - \text{USBPx[N]} |$
- Includes  $V_{DI}$  range
- Applies to Low-Speed/High-Speed USB
- PCI Express mVdiff p-p =  $2 * | \text{PETp[x]} - \text{PETn[x]} |$
- GLAN mVdiff p-p =  $2 * | \text{GLAN\_RXp} - \text{GLAN\_RXn} |$
- SATA Vdiff, Rx ( $V_{IMAX10/MIN10}$ ) is measured at the SATA connector on the receiver side (generally, the motherboard connector), where SATA mVdiff p-p =  $2 * | \text{SATA[x]RXP} - \text{SATA[x]RXN} |$
- V<sub>CC</sub>RTC is the voltage applied to the V<sub>CC</sub>RTC well of the ICH8. When the system is in a G3 state, this is generally supplied by the coin cell battery, but for S5 and greater, this is generally V<sub>CC</sub>Sus3\_3.
- CL\_Vref = 0.27 (V<sub>CC</sub>CL1\_5). CL\_VREF0 applies to Desktop configurations. CL\_VREF1 applies to Mobile configurations.
- Applies to Ultra DMA Modes greater than Ultra DMA Mode 4
- This is an AC Characteristic that represents transient values for these signals



Table 153. DC Characteristic Output Signal Association (Sheet 1 of 2)

Symbol	Associated Signals
$V_{OH1}/V_{OL1}$	<b>Processor Signals:</b> Desktop: A20M#, CPUSLP#, IGNNE#, INIT#, INTR, NMI, SMI#, STPCLK#, CPUPWRGD/GPIO[49] Mobile: A20M#, DPSLP#, IGNNE#, INIT#, INTR, NMI, SMI#, STPCLK#, CPUPWRGD/GPIO[49]
$V_{OH2}/V_{OL2}$	<b>PCI Signals:</b> AD[31:0], C/BE[3:0]#, DEVSEL#, FRAME#, IRDY#, PAR, PERR#, PLOCK#, SERR# <sup>(1)</sup> , STOP#, TRDY# <b>Intel® High Definition Audio Signals:</b> HDA_RST#, HDA_SDOUT, HDA_SYNC, HDA_BIT_CLK <b>NOTE:</b> See $V_{OH\_HDA}/V_{OL\_HDA}$ for High Definition Audio Low Voltage Mode
$V_{OH3}/V_{OL3}$	<b>SMBus Signals:</b> SMBCLK <sup>(1)</sup> , SMBDATA <sup>(1)</sup> <b>System Management Signals:</b> SMLINK[1:0] <sup>(1)</sup> , LINKALERT# <sup>(1)</sup> <b>GPIO Signals:</b> GPIO11/SMBALERT <sup>(1)</sup>
$V_{OH4}/V_{OL4}$	<b>Power Management Signals:</b> Desktop: SLP_S3#, SLP_S4#, SLP_S5#, SLP_M#, S4_STATE#/GPIO26, SUSCLK, SUS_STAT#/LPCPD, CK_PWRGD Mobile: DPRSLPVR, SLP_S3#, SLP_S4#, SLP_S5#, SLP_M#, S4_STATE#/GPIO26, SUSCLK, SUS_STAT/LPCPD, CK_PWRGD# <b>GPIO Signals:</b> Desktop: GPIO[39, 38, 37, 36, 33, 32, 21, 20, 19,18, 16, 7, 6,0] Mobile: GPIO[39, 38, 37, 36, 21, 20, 19,18, 7, 6,0] Intel High Definition Audio Signals: HDA_DOCK_EN#/GPIO33 (Mobile Only) <b>Other Signals:</b> SPKR <b>Interrupt Signals:</b> SERIRQ <b>SATA Signal:</b> SATALED#, SATACLKREQ#/GPIO35, SLOAD/GPIO38, SDATAOUT[1:0]/GPIO[48,39], SDATAOUT
$V_{OH5}/V_{OL5}$	<b>USB Signals:</b> USBP[9:0][P,N] in Low-speed and Full-speed Modes
$V_{OMIN6}/V_{OMAX6}$	<b>PCI Express* Data TX Signals:</b> PET[p,n][6:1]
$V_{OMIN7}/V_{OMAX7}$	<b>SATA Signals:</b> Desktop: SATA[5:0]TX[P,N] Mobile: SATA[2,0]TX[P,N]
$V_{OH8}/V_{OL8}$	<b>LPC/Firmware Hub Signals:</b> LAD[3:0]/FWH[3:0], LFRAME#/FWH[4] <b>Power Management Signal:</b> PLTRST# <b>PCI Signals:</b> PCIRST#, GNT[3:1]#/GPIO[55,53,51], GNT[0]#, PME# <sup>(1)</sup> <b>GPIO Signals:</b> Desktop: GPIO[54, 52, 50, 34, 23, 22, 5, 4, 3, 2, 1] Mobile: GPIO[54, 52, 50, 23, 22, 5, 4, 3, 2, 1] <b>Intel High Definition Audio Signals:</b> HDA_DOCK_RST#/GPIO34 (Mobile Only) <b>SPI Signals:</b> SPI_CS[1:0]#, SPI_MOSI, SPI_CLK <b>Processor Interface Signal:</b> INIT3_3V# (Desktop Only) <b>LAN Signals:</b> LAN_RSTSYNC, LAN_TXD[2:0] <b>Interrupt Signals:</b> PIRQ[H:E] # <sup>(1)</sup> /GPIO[5:2]
$V_{OH9}/V_{OL9}$	<b>Power Management Signals:</b> Mobile: STP_CPU#, STP_PCI# <b>GPIO Signals:</b> GPIO[25, 15, 13, 12, 8], GPIO[43:40]/OC[4:1]#,GPIO[31:29]/OC[7:5]#, GPIO9/WOL_EN, GPIO10/ALERT#GPIO14/NETDETECT, GPIO24/MEM_LED <b>Intel Quick Resume Technology Signals (ICH8DH Only):</b> QRT_STATE[1:0]
$V_{OMIN10}/V_{OMAX10}$	<b>Gigabit Lan Connect Signals:</b> GLAN_TX[p,n]



Table 153. DC Characteristic Output Signal Association (Sheet 2 of 2)

Symbol	Associated Signals
$V_{OH11}/V_{OL11}$	<b>IDE Signals (Mobile Only):</b> DA[2:0], DCS[3,1]#, DDACK#, DD[15:0], DIOR#, DIOW#
$V_{HSOI}$ $V_{HSOH}$ $V_{HSOL}$ $V_{CHIRPJ}$ $V_{CHIRPK}$	<b>USB Signals:</b> USBP[9:0][P:N] in High-speed Mode
$V_{OH\_HDA}/V_{OL\_HDA}$	<b>Intel® High Definition Audio Signals:</b> HDA_RST#, HDA_SDOOUT, HDA_SYNC <b>NOTE:</b> Only applies when running in Low Voltage Mode (1.5 V)
$V_{OH\_PWM}/V_{OL\_PWM}$	<b>Fan Speed Control PWM:</b> PWM[2:0] <sup>(1)</sup>
$V_{OH\_CL1}/V_{OL\_CL1}$	<b>Link Controller Signals:</b> CL_CLK0, CL_DATA0 Mobile Only: CL_CLK1, CL_DATA1
$V_{OH\_CL2}/V_{OL\_CL2}$	<b>Link Controller Signals:</b> CL_RST#
$V_{OH\_SST}/V_{OL\_SST}$	<b>SST signal:</b> SST
$V_{OH\_PECI}/V_{OL\_PECI}$	<b>PECI signal:</b> Peci (Desktop Only)

**NOTE:**

1. These signals are open drain.



Table 154. DC Output Characteristics (Sheet 1 of 2)

Symbol	Parameter	Min	Max	Unit	I <sub>OL</sub> / I <sub>OH</sub>	Notes
V <sub>OL1</sub>	Output Low Voltage	—	0.255	V	3 mA	4
V <sub>OH1</sub>	Output High Voltage	V <sub>CPU_IO</sub> - 0.3	—	V	-3 mA	
V <sub>OL2</sub>	Output Low Voltage	—	0.1(V <sub>CC3_3</sub> )	V	1.5 mA	
V <sub>OH2</sub>	Output High Voltage	0.9(V <sub>CC3_3</sub> )	—	V	-0.5 mA	
V <sub>OL3</sub>	Output Low Voltage	—	0.4	V	4 mA	
V <sub>OH3</sub>	Output High Voltage	V <sub>CCSus3_3</sub> - 0.5	—	V	-2 mA	1
V <sub>OL4</sub>	Output Low Voltage	—	0.4	V	6 mA	
V <sub>OH4</sub>	Output High Voltage	V <sub>CC3_3</sub> - 0.5	—	V	-2 mA	
V <sub>OL5</sub>	Output Low Voltage	—	0.4	V	5 mA	
V <sub>OH5</sub>	Output High Voltage	V <sub>CC3_3</sub> - 0.5	—	V	-2 mA	
V <sub>OMIN6</sub>	Minimum Output Voltage	800	—	mVdifferential peak-to-peak		2
V <sub>OMAX6</sub>	Maximum Output Voltage	—	1200	mVdifferential peak-to-peak		2
V <sub>OMIN7-Gen1i,m</sub>	Minimum Output Voltage - 1.5 Gb/s internal SATA and eSATA	400		mVdifferential peak-to-peak		3
V <sub>OMAX7-Gen1i,m</sub>	Maximum Output Voltage 1.5 Gb/s internal SATA and eSATA		600	mVdifferential peak-to-peak		3
V <sub>OMIN7-Gen2i,m</sub>	Minimum Output Voltage 3.0 Gb/s internal SATA and eSATA	400		mVdifferential peak-to-peak		3
V <sub>OMAX7-Gen2i,m</sub>	Maximum Output Voltage 3.0 Gb/s internal SATA and eSATA		700	mVdifferential peak-to-peak		3
V <sub>OL8</sub>	Output Low Voltage	—	0.1(V <sub>CC3_3</sub> )	V	1.5 mA	
V <sub>OH8</sub>	Output High Voltage	0.9(V <sub>CC3_3</sub> )		V	-0.5 mA	1
V <sub>OL9</sub>	Output Low Voltage	—	0.4	V	6 mA	
V <sub>OH9</sub>	Output High Voltage	V <sub>CCSus3_3</sub> - 0.5	—	V	-0.5 mA	
V <sub>OMIN10</sub>	Minimum Output Voltage	750	—	mVdifferential peak-to-peak		6
V <sub>OMAX10</sub>	Maximum Output Voltage	—	1350	mVdifferential peak-to-peak		6
V <sub>OL11</sub>	Output Low Voltage	—	0.51	V	6 mA	
V <sub>OH11</sub>	Output High Voltage	V <sub>CC3_3</sub> - 0.51	—	V	-6 mA	
V <sub>HSOI</sub>	HS Idle Level	-10.0	10.0	mV		
V <sub>HSOH</sub>	HS Data Signaling High	360	440	mV		
V <sub>HSOL</sub>	HS Data Signaling Low	-10.0	10.0	mV		
V <sub>CHIRPJ</sub>	Chirp J Level	700	1100	mV		
V <sub>CHIRPK</sub>	Chirp K Level	-900	-500	mV		



Table 154. DC Output Characteristics (Sheet 2 of 2)

Symbol	Parameter	Min	Max	Unit	$I_{OL} / I_{OH}$	Notes
$V_{OL\_HDA}$ (Mobile Only)	Output Low Voltage	—	0.1(V <sub>ccHDA</sub> )	V	1.5 mA	
$V_{OH\_HDA}$ (Mobile Only)	Output High Voltage	0.9(V <sub>cc_HDA</sub> )	—	V	-0.5 mA	
$V_{OL\_PWM}$	Output Low Voltage	—	0.4	V	8 mA	
$V_{OH\_PWM}$	Output High Voltage	—	—			1
$V_{OL\_CL1}$	Output Low Voltage	—	0.1	V	1 mA	
$V_{OH\_CL1}$	Output High Voltage	0.485(V <sub>ccCL1_5</sub> )	—	V		
$V_{OL\_CL2}$	Output Low Voltage	—	0.1(V <sub>ccCL1_5</sub> )	V	1.5 mA	
$V_{OH\_CL2}$	Output High Voltage	0.9(V <sub>ccCL1_5</sub> )	—	V	-1.5 mA	
$V_{OL\_SST}$	Output Low Voltage	—	0.3	V	0.5 mA	
$V_{OH\_SST}$	Output High Voltage	1.1	—	V	-6 mA	
$V_{OL\_PECI}$	Output Low Voltage	—	0.25(V <sub>_CPU_IO</sub> )	V	0.5 mA	
$V_{OH\_PECI}$	Output High Voltage	0.75(V <sub>_CPU_IO</sub> )	—		-6 mA	

**NOTES:**

1. The SERR#, PIRO[H:A], SMBDATA, SMBCLK, LINKALERT#, SMLINK[1:0], and PWM[2:0] signal has an open drain driver and SATALED# has an open collector driver, and the  $V_{OH}$  specification does not apply. This signal must have external pull up resistor.
2. PCI Express mVdiff p-p =  $2 * |PETp[x] - PETn[x]|$
3. SATA Vdiff, tx ( $V_{OMIN7}/V_{OMAX7}$ ) is measured at the SATA connector on the transmit side (generally, the motherboard connector), where SATA mVdiff p-p =  $2 * |SATA[x]TXP - SATA[x]TXN|$
4. Maximum Iol for CPUPWRGD is 12mA for short durations (<500mS per 1.5 s) and 9mA for long durations.
5. For INIT3\_3V only, for low current devices, the following applies: VOL5 Max is 0.15 V at an IOL5 of 2 mA.
6. GLAN mVdiff p-p =  $2 * |GLAN\_TXp - GLAN\_TXn|$



Table 155. Other DC Characteristics (Sheet 1 of 2)

Symbol	Parameter	Min	Nom	Max	Unit	Notes
V_CPU_IO (Desktop Only)	Processor Interface	1.14	—	1.26	V	1
V_CPU_IO (Mobile Only)	Processor Interface	0.945	—	1.155	V	1
V_CPU_IO (Server Only)	Processor Interface	1.18	—	1.3	V	1
V5REF	ICH8 Core Well Reference Voltage	4.75	5	5.25	V	1
CL_VREF0, CL_VREF1	Controller Link Reference Voltage	0.385	0.405	0.425	V	1
Vcc3_3	I/O Buffer Voltage	3.135	3.3	3.465	V	1
Vcc1_5_A, Vcc1_5_B, VccUSBPLL, VccSATAPLL, VccDMIPLL, VccGLANPLL	Internal Logic and I/O Buffer Voltage	1.425	1.5	1.575	V	1
V5REF_Sus	Suspend Well Reference Voltage	4.75	5	5.25	V	1
VccSus3_3	Suspend Well I/O Buffer Voltage	3.135	3.3	3.465	V	1
Vcc1_05	Internal Logic Voltage	0.998	1.05	1.102	V	1
VccSus1_05	Suspend Well Logic Voltage	0.998	1.05	1.102	V	1
VccSus1_5	Suspend Well I/O Buffer Voltage	1.425	1.5	1.575	V	1
VccHDA	High Definition Audio Controller Core Voltage	3.135	3.3	3.465	V	1
VccHDA (low voltage 1.5 V)	High Definition Audio Controller Low Voltage Mode Core Voltage	1.425	1.5	1.575	V	1
Vcc_DMI	DMI Buffer Voltage	1.186	—	1.312	V	Same as Vcc1_5_A if powered by 1.5 V.
VccLAN3_3	LAN Controller I/O Buffer Voltage	3.135	3.3	3.465	V	1
VccLAN1_05	LAN Controller Logic Voltage	0.998	1.05	1.102	V	1
VccGLAN1_5	Gigabit Lan Transmitter and Receiver Voltage	1.425	1.5	1.575	V	1
VccGLAN3_3	Gigabit Lan Internal Logic and I/O Buffer Voltage	3.135	3.3	3.465	V	1
VccCL3_3	Controller Link Buffer Voltage	3.135	—	3.465	V	1
VccRTC (G3–S0)	Battery Voltage	2	—	3.465	V	1
VccSusHDA	High Definition Audio Controller Suspend Voltage	3.135	3.3	3.465	V	1



Table 155. Other DC Characteristics (Sheet 2 of 2)

Symbol	Parameter	Min	Nom	Max	Unit	Notes
VccSusHDA (low voltage)	Intel High Definition Audio Controller Low Voltage Mode Suspend Voltage	1.425	1.5	1.575	V	1
VccCL1_05	Controller Link Logic Voltage	0.998	—	1.102	V	1
VccCL1_5	Controller Link Logic Voltage	1.425	—	1.575	V	1
V <sub>DI</sub>	Differential Input Sensitivity	0.2	—	—	V	(USBPx+, USBPx-)
V <sub>CM</sub>	Differential Common Mode Range	0.8	—	2.5	V	Includes V <sub>DI</sub>
V <sub>CRS</sub>	Output Signal Crossover Voltage	1.3	—	2.0	V	
V <sub>SE</sub>	Single Ended Rcvr Threshold	0.8	—	2.0	V	
I <sub>LI1</sub>	ATA Input Leakage Current	-200	—	200	μA	(0 V < V <sub>IN</sub> < 5V)
I <sub>LI2</sub>	PCI_3V Hi-Z State Data Line Leakage	-10	—	10	μA	(0 V < V <sub>IN</sub> < Vcc3_3)
I <sub>LI3</sub>	PCI_5V Hi-Z State Data Line Leakage	-70	—	70	μA	Max V <sub>IN</sub> = 2.7 V Min V <sub>IN</sub> = 0.5 V
I <sub>LI4</sub>	Input Leakage Current – Clock signals	-100	—	+100	μA	2
V <sub>IL TACH</sub>	Input Low Voltage	—	—	0.3(Vcc3_3)		
V <sub>IH TACH</sub>	Input High Voltage	0.6(Vcc3_3)	—	-		
C <sub>IN</sub>	Input Capacitance – All Other	—	—	12	pF	F <sub>C</sub> = 1 MHz
C <sub>OUT</sub>	Output Capacitance	—	—	12	pF	F <sub>C</sub> = 1 MHz
C <sub>I/O</sub>	I/O Capacitance	—	—	12	pF	F <sub>C</sub> = 1 MHz
		Typical Value				
C <sub>L</sub>	XTAL1	6			pF	
C <sub>L</sub>	XTAL2	6			pF	

**NOTES:**

- The I/O buffer supply voltage is measured at the ICH8 package pins. The tolerances shown in Table 155 are inclusive of all noise from DC up to 20 MHz. In testing, the voltage rails should be measured with a bandwidth limited oscilloscope that has a rolloff of 3 dB/decade above 20 MHz.
- Includes CLK14, CLK48, GLAN\_CLK, and PCICLK.



## 23.4 AC Characteristics

Table 156. Clock Timings (Sheet 1 of 2)

Sym	Parameter	Min	Max	Unit	Notes	Figure
<b>PCI Clock (PCICLK)</b>						
t1	Period	30	33.3	ns		22
t2	High Time	12	—	ns		22
t3	Low Time	12	—	ns		22
t4	Rise Time	—	3	ns		22
t5	Fall Time	—	3	ns		22
<b>14 MHz Clock (CLK14)</b>						
t6	Period	67	70	ns		22
t7	High Time	20	—	ns		22
t8	Low Time	20	—	ns		22
t41	Rising Edge Rate	1.0	4.0	V/ns	5	
t42	Falling Edge Rate	1.0	4.0	V/ns	5	
<b>48 MHz Clock (CLK48)</b>						
f <sub>clk48</sub>	Operating Frequency	48.000	—	MHz	1	
t9	Frequency Tolerance	—	100	ppm		
t10	High Time	7	—	ns		22
t11	Low Time	7	—	ns		22
t12	Rise Time	—	1.2	ns		22
t13	Fall Time	—	1.2	ns		22
<b>SMBus Clock (SMBCLK)</b>						
f <sub>smb</sub>	Operating Frequency	10	100	KHz		
t18	High time	4.0	50	us	2	37
t19	Low time	4.7	—	us		37
t20	Rise time	—	1000	ns		37
t21	Fall time	—	300	ns		37
<b>HDA_BIT_CLK (Intel® High Definition Audio)</b>						
fHDA	Operating Frequency	24.0		MHz		
	Frequency Tolerance	—	100	ppm		
t26a	Input Jitter (refer to Clock Chip Specification)	—	300	ppm		
t27a	High Time (Measured at 0.75V <sub>cc</sub> )	18.75	22.91	ns		22
t28a	Low Time (Measured at 0.35V <sub>cc</sub> )	18.75	22.91	ns		22





Table 156. Clock Timings (Sheet 2 of 2)

Sym	Parameter	Min	Max	Unit	Notes	Figure
<b>SATA Clock (SATA_CLKP, SATA_CLKN) / DMI Clock (DMI_CLKP, DMI_CLKN)</b>						
t36	Period	9.997	10.0533	ns		
t37	Rise time	175	700	ps		
t38	Fall time	175	700	ps		
tsatasl	Slew rate	2.5	8	V/ns		
<b>Suspend Clock (SUSCLK)</b>						
f <sub>susclk</sub>	Operating Frequency	32		kHz	4	
t39	High Time	10	—	us	4	
t39a	Low Time	10	—	us	4	
<b>Gigabit Internet Clock (GLAN_CLK)</b>						
tglanclk	Operating Frequency	5	62.5	MHz	6	
tglanhi	High Time	8.5	—	ns		
tglanlo	Low Time	8.5	—	ns		
tglanl	Slew rate	1.0	4	V/ns		
<b>Fan Speed Controller</b>						
fpwm	PWM Operating Frequency	10	28,000	Hz		

**NOTES:**

1. The CLK48 expects a 40/60% duty cycle.
2. The maximum high time (t18 Max) provide a simple assured method for devices to detect bus idle conditions.
3. BITCLK Rise and Fall times are measured from 10%VDD and 90%VDD.
4. SUSCLK duty cycle can range from 30% minimum to 70% maximum.
5. CLK14 edge rates in a system as measured from 0.8 V to 2.0 V.
6. The active frequency can be 5 MHz, 50 MHz or 62.5 MHz depending on the interface speed. Dynamic changes of the normal operating frequency are not allowed.



Table 157. PCI Interface Timing

Sym	Parameter	Min	Max	Units	Notes	Figure
t40	AD[31:0] Valid Delay	2	11	ns	1	23
t41	AD[31:0] Setup Time to PCICLK Rising	7	—	ns		24
t42	AD[31:0] Hold Time from PCICLK Rising	0	—	ns		24
t43	C/BE[3:0]#, FRAME#, TRDY#, IRDY#, STOP#, PAR, PERR#, PLOCK#, DEVSEL# Valid Delay from PCICLK Rising	2	11	ns	1	23
t44	C/BE[3:0]#, FRAME#, TRDY#, IRDY#, STOP#, PAR, PERR#, PLOCK#, IDSEL, DEVSEL# Output Enable Delay from PCICLK Rising	2	—	ns		27
t45	C/BE[3:0]#, FRAME#, TRDY#, IRDY#, STOP#, PERR#, PLOCK#, DEVSEL#, GNT[A:B]# Float Delay from PCICLK Rising	2	28	ns		25
t46	C/BE[3:0]#, FRAME#, TRDY#, IRDY#, STOP#, SERR#, PERR#, DEVSEL#, Setup Time to PCICLK Rising	7	—	ns		24
t47	C/BE[3:0]#, FRAME#, TRDY#, IRDY#, STOP#, SERR#, PERR#, DEVSEL#, REQ[A:B]# Hold Time from PCLKIN Rising	0	—	ns		24
t48	PCIRST# Low Pulse Width	1		ms		26
t49	GNT[3:0]# Valid Delay from PCICLK Rising	2	12	ns		
t50	REQ[3:0]# Setup Time to PCICLK Rising	12	—	ns		

**NOTES:**

1. Refer to note 3 of Table 4-4 in Section 4.2.2.2 and note 2 of Table 4-6 in Section 4.2.3.2 of the *PCI Local Bus Specification*, Revision 2.3 for measurement details.



Table 158. IDE PIO Mode Timings (Mobile Only)

Sym	Parameter	Mode 0 (nS)	Mode 1 (nS)	Mode 2 (nS)	Mode 3 (nS)	Mode 4 (nS)	Figure
t60	Cycle Time (min)	600	383	240	180	120	28
t61	Addr setup to DIOW#/DIOR# (min)	70	50	30	30	25	28
t62	DIRW#/DIOR# (min)	165	125	100	80	70	28
t62i	DIOW#/DIOR# recovery time (min)	—	—	—	70	25	28
t63	DIOW# data setup (min)	60	45	30	30	20	28
t64	DIOW# data hold (min)	30	20	15	10	10	28
t65	DIOR# data setup (min)	50	35	20	20	20	28
t66	DIOR# data hold (min)	5	5	5	5	5	28
t66z	DIOR# data tristate (max)	30	30	30	30	30	28
t69	DIOW#/DIOR# to address valid hold (min)	20	15	10	10	10	28
t60rd	Read data Valid to IORDY active (min)	0	0	0	0	0	28
t60a	IORDY Setup	35	35	35	35	35	28
t60b	IORDY Pulse Width (max)	1250	1250	1250	1250	1250	28
t60c	IORDY assertion to release (max)	5	5	5	5	5	28



**Table 159. IDE Multiword DMA Timings (Mobile Only)**

Sym	Parameter	Mode 0 (nS)	Mode 1 (nS)	Mode 2 (nS)	Figure
t70	Cycle Time (min)	480	150	120	29
t70d	DIOR#/DIOw# (min)	215	80	70	29
t70e	DIOR# Data access (max)	150	60	50	29
t70f	DIOR# Data hold (min)	5	5	5	29
t70g	DIOR#/DIOw# Data setup (min)	100	30	20	29
t70h	DIOw# Data hold (min)	20	15	10	29
t70i	DDACK# to DIOR#/DIOw# setup (min)	0	0	0	29
t70j	DIOR#/DIOw# to DDACK# hold (min)	20	5	5	29
t70kr	DIOR# negated pulse width (min)	50	50	25	29
t70kw	DIOw# negated pulse width (min)	215	50	25	29
t70lr	DIOR# to DDREQ delay (max)	120	40	35	29
t70lw	DIOw# to DDREQ delay (max)	40	40	35	29
t70m	DCS1#/DCS3# valid to DIOR#/DIOw# (min)	50	30	25	29
t70n	DCS1#/DCS3# hold (min)	15	10	10	29
t70z	DDACK# to tristate (max)	20	25	25	29

**Table 160. Ultra ATA Timing (Mode 0, Mode 1, Mode 2) (Sheet 1 of 3) (Mobile Only)**

Sym	Parameter (1)	Mode 0 (ns)		Mode 1 (ns)		Mode 2 (ns)		Measuring Location	Figure
		Min	Max	Min	Max	Min	Max		
t80	Sustained Cycle Time (T2cyc <sub>typ</sub> )	240		160		120		Sender Connector	
t81	Cycle Time (T <sub>cyc</sub> )	112	—	73	—	54	—	End Recipient Connector	31
t82	Two Cycle Time (T2cyc)	230	—	153	—	115	—	Sender Connector	31
t83a	Data Setup Time (T <sub>ds</sub> )	15	—	10	—	7	—	Recipient Connector	31
t83b	Recipient IC data setup time (from data valid until STROBE edge) (see Note 2) (T <sub>dsic</sub> )	14.7	—	9.7	—	6.8	—	ICH8 ball	
t84a	Data Hold Time (T <sub>dh</sub> )	5	—	5	—	5	—	Recipient Connector	31



Table 160. Ultra ATA Timing (Mode 0, Mode 1, Mode 2) (Sheet 2 of 3) (Mobile Only)

Sym	Parameter (1)	Mode 0 (ns)		Mode 1 (ns)		Mode 2 (ns)		Measuring Location	Figure
		Min	Max	Min	Max	Min	Max		
t84b	Recipient IC data hold time (from STROBE edge until data may become invalid) (see Note 2) (Tdhic)	4.8	—	4.8	—	4.8	—	ICH8 ball	
t85a	Data Valid Setup Time (Tdvs)	70	—	48	—	31	—	Sender Connector	31
t85b	Sender IC data valid setup time (from data valid until STROBE edge) (see Note 2) (Tdvsic)	72.9	—	50.9	—	33.9	—	ICH8 ball	
t86a	Data Valid Hold Time (Tdvh)	6.2	—	6.2	—	6.2	—	Sender Connector	31
t86b	Sender IC data valid hold time (from STROBE edge until data may become invalid) (see Note 2) (Tdvhic)	9	—	9	—	9	—	ICH8 ball	
t87	Limited Interlock Time (Tli)	0	150	0	150	0	150	See Note 2	33
t88	Interlock Time w/ Minimum (Tmli)	20	—	20	—	20	—	Host Connector	33
t89	Envelope Time (Tenv)	20	70	20	70	20	70	Host Connector	30
t90	Ready to Pause Time (Trp)	160	—	125	—	100	—	Recipient Connector	32
t91	DMACK setup/hold Time (Tack)	20	—	20	—	20	—	Host Connector	30, 33
t92a	CRC Word Setup Time at Host (Tcvs)	70	—	48	—	31	—	Host Connector	
t92b	CRC word valid hold time at sender (from DMACK# negation until CRC may become invalid) (see Note 2) (Tcvh)	6.2	—	6.2	—	6.2	—	Host Connector	
t93	STROBE output released-to-driving to the first transition of critical timing (Tzfs)	0	—	0	—	0	—	Device Connector	33
t94	Data Output Released-to-Driving Until the First Transition of Critical Timing (Tdzfs)	70	—	48	—	31	—	Sender Connector	30
t95	Unlimited Interlock Time (Tui)	0	—	0	—	0	—	Host Connector	30



Table 160. Ultra ATA Timing (Mode 0, Mode 1, Mode 2) (Sheet 3 of 3) (Mobile Only)

Sym	Parameter (1)	Mode 0 (ns)		Mode 1 (ns)		Mode 2 (ns)		Measuring Location	Figure
		Min	Max	Min	Max	Min	Max		
t96a	Maximum time allowed for output drivers to release (from asserted or negated) (Tz <sub>a</sub> )	—	10		10	—	10	See Note 2	
t96b	Minimum time for drivers to assert or negate (from released) (Tz <sub>a</sub> d)	0	—	0	—	0	—	Device Connector	
t97	Ready-to-final-STROBE time (no STROBE edges shall be sent this long after negation of DMARDY#) (Tr <sub>f</sub> s)	—	75	—	70	—	60	Sender Connector	30
t98a	Maximum time before releasing IORDY (Tiord <sub>y</sub> z)	—	20	—	20	—	20	Device Connector	
t98b	Minimum time before driving IORDY (see Note 2) (Tziord <sub>y</sub> )	0	—	0	—	0	—	Device Connector	
t99	Time from STROBE edge to negation of DMARQ or assertion of STOP (when sender terminates a burst) (T <sub>ss</sub> )	50	—	50	—	50	—	Sender Connector	32

**NOTES:**

1. The specification symbols in parentheses correspond to the AT Attachment – 6 with Packet Interface (ATA/ATAPI – 6) specification name.
2. See the AT Attachment – 6 with Packet Interface (ATA/ATAPI – 6) specification for further details on measuring these timing parameters.



Table 161. Ultra ATA Timing (Mode 3, Mode 4, Mode 5) (Sheet 1 of 2) (Mobile Only)

Sym	Parameter (1)	Mode 3 (ns)		Mode 4 (ns)		Mode 5 (ns)		Measuring Location	Figure
		Min	Max	Min	Max	Min	Max		
t80	Sustained Cycle Time (T2cyc <sub>typ</sub> )	90		60		40		Sender Connector	
t81	Cycle Time (T <sub>cyc</sub> )	39	—	25	—	16.8	—	End Recipient Connector	31
t82	Two Cycle Time (T2cyc)	86	—	57	—	38	—	Sender Connector	31
t83	Data Setup Time (T <sub>ds</sub> )	7	—	5	—	4.0	—	Recipient Connector	31
t83b	Recipient IC data setup time (from data valid until STROBE edge) (see Note 2) (T <sub>dsic</sub> )	6.8	—	4.8	—	2.3	—	ICH8 Balls	
t84	Data Hold Time (T <sub>dh</sub> )	5	—	5	—	4.6	—	Recipient Connector	31
t84b	Recipient IC data hold time (from STROBE edge until data may become invalid) (see Note 2) (T <sub>dhic</sub> )	4.8	—	4.8	—	2.8	—	ICH8 Balls	
t85	Data Valid Setup Time (T <sub>dvs</sub> )	20	—	6.7	—	4.8	—	Sender Connector	30 31
t85b	Sender IC data valid setup time (from data valid until STROBE edge) (see Note 2) (T <sub>dvsic</sub> )	22.6	—	9.5	—	6.0	—	ICH8 Balls	
t86	Data Valid Hold Time (T <sub>dvh</sub> )	6.2	—	6.2	—	4.8	—	Sender Connector	30 31
t86b	Sender IC data valid hold time (from STROBE edge until data may become invalid) (see Note 2) (T <sub>dvhic</sub> )	9.0	—	9.0	—	6.0	—	ICH8 Balls	
t87	Limited Interlock Time (T <sub>li</sub> )	0	100	0	100	0	75	See Note 2	33
t88	Interlock Time w/ Minimum (T <sub>mli</sub> )	20	—	20	—	20	—	Host Connector	33
t89	Envelope Time (T <sub>env</sub> )	20	55	20	55	20	50	Host Connector	31
t90	Ready to Pause Time (T <sub>rp</sub> )	100	—	100	—	85	—	Recipient Connector	32
t91	DMACK setup/hold Time (T <sub>ack</sub> )	20	—	20	—	20	—	Host Connector	33
t92a	CRC Word Setup Time at Host (T <sub>cv<sub>s</sub></sub> )	20	—	6.7	—	10	—	Host Connector	



Table 161. Ultra ATA Timing (Mode 3, Mode 4, Mode 5) (Sheet 2 of 2) (Mobile Only)

Sym	Parameter (1)	Mode 3 (ns)		Mode 4 (ns)		Mode 5 (ns)		Measuring Location	Figure
		Min	Max	Min	Max	Min	Max		
t92b	CRC Word Hold Time at Sender CRC word valid hold time at sender (from DMACK# negation until CRC may become invalid) (see Note 2) (Tcvh)	6.2	—	6.2	—	10.0	—	Host Connector	
t93	STROBE output released-to-driving to the first transition of critical timing (Tzfs)	0	—	0	—	35	—	Device Connector	33
t94	Data Output Released-to-Driving Until the First Transition of Critical Timing (Tdzfs)	20.0	—	6.7	—	25	—	Sender Connector	
t95	Unlimited Interlock Time (Tui)	0	—	0	—	0	—	Host Connector	
t96a	Maximum time allowed for output drivers to release (from asserted or negated) (Taz)	—	10	—	10	—	10	See Note 2	
t96b	Drivers to assert or negate (from released) (Tzad)	0	—	0	—	0	—	Device Connector	
t97	Ready-to-final-STROBE time (no STROBE edges shall be sent this long after negation of DMARDY#) (Trfs)	—	60	—	60	—	50	Sender Connector	
t98a	Maximum time before releasing IORDY (Tiordyz)	—	20	—	20	—	20	Device Connector	
t98b	Minimum time before driving IORDY (see Note 2) (Tziordy)	0	—	0	—	0	—	Device Connector	
t99	Time from STROBE edge to negation of DMARQ or assertion of STOP (when sender terminates a burst) (Tss)	50	—	50	—	50	—	Sender Connector	32

**NOTES:**

1. The specification symbols in parentheses correspond to the AT Attachment – 6 with Packet Interface (ATA/ATAPI – 6) specification name.
2. See the AT Attachment – 6 with Packet Interface (ATA/ATAPI – 6) specification for further details on measuring these timing parameters.





Table 162. Universal Serial Bus Timing

Sym	Parameter	Min	Max	Units	Fig	Notes
<b>Full-speed Source (Note 7)</b>						
t100	USBPx+, USBPx- Driver Rise Time	4	20	ns	34	1, C <sub>L</sub> = 50 pF
t101	USBPx+, USBPx- Driver Fall Time	4	20	ns	34	1, C <sub>L</sub> = 50 pF
t102	Source Differential Driver Jitter To Next Transition For Paired Transitions	-3.5 -4	3.5 4	ns ns	35	2, 3
t103	Source SEO interval of EOP	160	175	ns	36	4
t104	Source Jitter for Differential Transition to SEO Transition	-2	5	ns		5
t105	Receiver Data Jitter Tolerance To Next Transition For Paired Transitions	-18.5 -9	18.5 9	ns ns	35	3
t106	EOP Width: Must accept as EOP	82	—	ns	36	4
t107	Width of SEO interval during differential transition	—	14	ns		
<b>Low-speed Source (Note 8)</b>						
t108	USBPx+, USBPx – Driver Rise Time	75	300	ns	34	1, 6 C <sub>L</sub> = 50 pF C <sub>L</sub> = 350 pF
t109	USBPx+, USBPx – Driver Fall Time	75	300	ns	34	1, 6 C <sub>L</sub> = 50 pF C <sub>L</sub> = 350 pF
t110	Source Differential Driver Jitter To Next Transition For Paired Transitions	-25 -14	25 14	ns ns	35	2, 3
t111	Source SEO interval of EOP	1.25	1.50	μs	36	4
t112	Source Jitter for Differential Transition to SEO Transition	-40	100	ns		5
t113	Receiver Data Jitter Tolerance To Next Transition For Paired Transitions	-152 -200	152 200	ns ns	35	3
t114	EOP Width: Must accept as EOP	670	—	ns	36	4
t115	Width of SEO interval during differential transition	—	210	ns		

**NOTES:**

1. Driver output resistance under steady state drive is spec'd at 28 ohms at minimum and 43 Ω at maximum.
2. Timing difference between the differential data signals.
3. Measured at crossover point of differential data signals.
4. Measured at 50% swing point of data signals.
5. Measured from last crossover point to 50% swing point of data line at leading edge of EOP.
6. Measured from 10% to 90% of the data signal.
7. Full-speed Data Rate has minimum of 11.97 Mb/s and maximum of 12.03 Mb/s.
8. Low-speed Data Rate has a minimum of 1.48 Mb/s and a maximum of 1.52 Mb/s.



**Table 163. SATA Interface Timings**

Sym	Parameter	Min	Max	Units	Figure	Notes
UI	Gen I Operating Data Period	666.43	670.23	ps		
UI-2	Gen II Operating Data Period (3Gb/s)	333.21	335.11	ps		
t120	Rise Time	0.15	0.41	UI		1
t121	Fall Time	0.15	0.41	UI		2
t122	TX differential skew	—	20	ps		
t123	COMRESET	310.4	329.6	ns		3
t124	COMWAKE transmit spacing	103.5	109.9	ns		3
t125	OOB Operating Data period	646.67	686.67	ns		4

**NOTES:**

1. 20% – 80% at transmitter
2. 80% – 20% at transmitter
3. As measured from 100 mV differential crosspoints of last and first edges of burst.
4. Operating data period during Out-Of-Band burst transmissions.

**Table 164. SMBus Timing**

Sym	Parameter	Min	Max	Units	Fig	Notes
t130	Bus Tree Time Between Stop and Start Condition	4.7	—	μs	37	
t131	Hold Time after (repeated) Start Condition. After this period, the first clock is generated.	4.0	—	μs	37	
t132	Repeated Start Condition Setup Time	4.7	—	μs	37	
t133	Stop Condition Setup Time	4.0	—	μs	37	
t134	Data Hold Time	0	—	ns	37	4
t135	Data Setup Time	250	—	ns	37	
t136	Device Time Out	25	35	ms		1
t137	Cumulative Clock Low Extend Time (slave device)	—	25	ms	38	2
t138	Cumulative Clock Low Extend Time (master device)	—	10	ms	38	3

**NOTES:**

1. A device will timeout when any clock low exceeds this value.
2. t137 is the cumulative time a slave device is allowed to extend the clock cycles in one message from the initial start to stop. If a slave device exceeds this time, it is expected to release both its clock and data lines and reset itself.
3. t138 is the cumulative time a master device is allowed to extend its clock cycles within each byte of a message as defined from start-to-ack, ack-to-ack or ack-to-stop.
4. t134 has a minimum timing for I<sup>2</sup>C of 0 ns, while the minimum timing for SMBus is 300 ns.



Table 165. Intel® High Definition Audio Timing

Sym	Parameter	Min	Max	Units	Fig	Notes
t143	Time duration for which HDA_SDOUT is valid before HDA_BIT_CLK edge.	7	—	ns	47	
t144	Time duration for which HDA_SDOUT is valid after HDA_BIT_CLK edge.	7	—	ns	47	
t145	Setup time for HDA_SDIN[3:0] at rising edge of HDA_BIT_CLK	15	—	ns	47	
t146	Hold time for HDA_SDIN[3:0] at rising edge of HDA_BIT_CLK	0	—	ns	47	

Table 166. LPC Timing

Sym	Parameter	Min	Max	Units	Fig	Notes
t150	LAD[3:0] Valid Delay from PCICLK Rising	2	11	ns	23	
t151	LAD[3:0] Output Enable Delay from PCICLK Rising	2	—	ns	27	
t152	LAD[3:0] Float Delay from PCICLK Rising	—	28	ns	25	
t153	LAD[3:0] Setup Time to PCICLK Rising	7	—	ns	24	
t154	LAD[3:0] Hold Time from PCICLK Rising	0	—	ns	24	
t155	LDRQ[1:0]# Setup Time to PCICLK Rising	12	—	ns	24	
t156	LDRQ[1:0]# Hold Time from PCICLK Rising	0	—	ns	24	
t157	LFRAME# Valid Delay from PCICLK Rising	2	12	ns	23	

Table 167. Miscellaneous Timings

Sym	Parameter	Min	Max	Units	Fig	Notes
t160	SERIRQ Setup Time to PCICLK Rising	7	—	ns	24	
t161	SERIRQ Hold Time from PCICLK Rising	0	—	ns	24	
t162	RI#, EXTSMI#, GPIO, USB Resume Pulse Width	2	—	RTCCLK	26	
t163	SPKR Valid Delay from OSC Rising	—	200	ns	23	
t164	SERR# Active to NMI Active	—	200	ns		
t165	IGNNE# Inactive from FERR# Inactive	—	230	ns		



**Table 168. SPI Timings (20 MHz)**

Sym	Parameter	Min	Max	Units	Fig	Notes
t180	Serial Clock Frequency - 20 MHz Operation	17.2	18.4	MHz		1
t182	SPI Clock Duty cycle at the host	40%	60%	—	48	
t183	Tco of SPI_MOSI with respect to serial clock falling edge at the host	-5	13	ns	48	
t184	Setup of SPI_MISO with respect to serial clock falling edge at the host	16	—	ns	48	
t185	Hold of SPI_MISO with respect to serial clock falling edge at the host	0	—	ns	48	
t186	Setup of SPI_CS[1:0]# assertion with respect to serial clock rising at the host	30	—	ns	48	
t187	Hold of SPI_CS[1:0]# deassertion with respect to serial clock falling at the host	30	—	ns	48	

**NOTES:**

1. The typical clock frequency driven by the ICH8 is 17.86 MHz.

**Table 169. SPI Timings (33 MHz)**

Sym	Parameter	Min	Max	Units	Fig	Notes
t180b	Serial Clock Frequency - 33MHz Operation	30.3	32.19	MHz		1
t182b	SPI Clock Duty cycle at the host	48%	52%	—	48	
t183b	Tco of SPI_MOSI with respect to serial clock falling edge at the host	-5	5	ns	48	
t184b	Setup of SPI_MISO with respect to serial clock falling edge at the host	8	—	ns	48	
t185b	Hold of SPI_MISO with respect to serial clock falling edge at the host	0	—	ns	48	
t186b	Setup of SPI_CS[1:0]# assertion with respect to serial clock rising at the host	30	—	ns	48	
t187b	Hold of SPI_CS[1:0]# deassertion with respect to serial clock falling at the host	30	—	ns	48	

**NOTE:**

1. The typical clock frequency driven by the ICH8 is 31.25 MHz.



Table 170. SST Timings (Desktop Only)

Sym	Parameter	Min	Max	Units	Fig	Notes
t <sub>BIT</sub>	Bit time (overall time evident on SST) Bit time driven by an originator	0.495 0.495	500 250	μs μs	39	1
t <sub>BIT,jitter</sub>	Bit time jitter between adjacent bits in an SST message header or data bytes after timing has been negotiated	—	—	%		
t <sub>BIT,drift</sub>	Change in bit time across a SST address or SST message bits as driven by the originator. This limit only applies across t <sub>BIT-A</sub> bit drift and t <sub>BIT-M</sub> drift.	—	—	%		
t <sub>H1</sub>	High level time for logic 1	0.6	0.8	x t <sub>BIT</sub>	39	2
t <sub>H0</sub>	High level time for logic 0	0.2	0.4	x t <sub>BIT</sub>	39	
t <sub>SSTR</sub>	Rise time (measured from V <sub>OL</sub> = 0.3V to V <sub>IH,min</sub> )	—	25 + 5	ns/node		
t <sub>SSTF</sub>	Fall time (measured from V <sub>OH</sub> = 1.1V to V <sub>IL,max</sub> )	—	33	ns/node		

**NOTE:**

1. The originator must drive a more restrictive time to allow for quantized sampling errors by a client yet still attain the minimum time less than 500μs. t<sub>BIT</sub> limits apply equally to t<sub>BIT-A</sub> and t<sub>BIT-M</sub>. ICH8 is targeted on 1Mbps which is 1μs bit time.
2. The minimum and maximum bit times are relative to t<sub>BIT</sub> defined in the Timing Negotiation pulse.

Table 171. PECL Timings (Desktop Only)

Sym	Parameter	Min	Max	Units	Fig	Notes
t <sub>BIT</sub>	Bit time (overall time evident on PECL) Bit time driven by an originator	0.495 0.495	500 250	μs μs	39	1
t <sub>BIT,jitter</sub>	Bit time jitter between adjacent bits in an PECL message header or data bytes after timing has been negotiated	—	—	%		
t <sub>BIT,drift</sub>	Change in bit time across a PECL address or PECL message bits as driven by the originator. This limit only applies across t <sub>BIT-A</sub> bit drift and t <sub>BIT-M</sub> drift.	—	—	%		
t <sub>H1</sub>	High level time for logic 1	0.6	0.8	x t <sub>BIT</sub>	39	2
t <sub>H0</sub>	High level time for logic 0	0.2	0.4	x t <sub>BIT</sub>	39	
t <sub>PECIR</sub>	Rise time (measured from V <sub>OL</sub> to V <sub>IH,min</sub> , V <sub>tt(nom)</sub> -5%)	—	30 + 5	ns/ node		3
t <sub>PECIF</sub>	Fall time (measured from V <sub>OH</sub> to V <sub>IL,max</sub> , V <sub>tt(nom)</sub> +5%)	—	30	ns/ node		3

**NOTE:**

1. The originator must drive a more restrictive time to allow for quantized sampling errors by a client yet still attain the minimum time less than 500 μs. t<sub>BIT</sub> limits apply equally to t<sub>BIT-A</sub> and t<sub>BIT-M</sub>. The ICH8 is targeted on 2 MHz which is 500 ns bit time.
2. The minimum and maximum bit times are relative to t<sub>BIT</sub> defined in the Timing Negotiation pulse.
3. Extended trace lengths may appear as additional nodes.



Table 172. Power Sequencing and Reset Signal Timings

Sym	Parameter	Min	Max	Units	Fig	Notes
t200	VccRTC active to RTCRST# inactive	18	—	ms	39 40	
t201	V5REF_Sus active to VccSus3_3 active	0	—	ms	39 40	1
t202	VccSus3_3 active to VccSus1_05 active	—	—	—	39 40	2
t203	VccRTC supply active to VccSus supplies active	0	—	ms	39 40	3
t204	VccSus supplies active to LAN_RST# inactive, RSMRST# inactive	10	—	ms	39 40	
t205	VccSus3_3 active to VccSus1_5 active	—	—	—		9
t206	VccLAN3_3 active to VccLAN1_05 active	—	—	—		6
t207	VccCL3_3 active to VccCL1_05 active	—	—	ms		7
t208	VccCL3_3 active to VccCL1_5 active	—	—	ms		8
t209	V5REF active to Vcc3_3 active	0	—	ms	39	1
t211	Vcc1_5 active to V_CPU_IO active	—	—	—	39	4
t212	VRMPWRGD active to PWROK active	3	—	ms	40 42 40	
t213	VccSus supplies active to Vcc supplies active	0	—	ms	39	3
t214	Vcc supplies active to PWROK Note: PWROK assertion indicates that PCICLK has been stable for at least 1 ms.	99	—	ms	39 40 42 43	
t215	Vcc active to STPCLK# and CPUSLP# (Desktop only) inactive	—	50	ns	40 42 43	
t217	PWROK and VRMPWRGD active to SUS_STAT# inactive and Processor I/F signals latched to strap value	32	38	RTCCLK	40 42 43 45	5, 10
t218	SUS_STAT# inactive to PLTRST# inactive	2	3	RTCCLK	40 42 43 45	10
t219	PLTRST# assertion to VccGLANPLL inactive for platforms using ICH8 integrated GbE LAN	200	—	μs		11
t228	HDA_RST# active low pulse width	1	—	us		
t229	HDA_RST# inactive to HDA_BIT_CLK startup delay	162.8	—	ns		

**NOTES:**

- V5REF must be powered up before Vcc3\_3, or after Vcc3\_3 within 0.7 V. Also, V5REF must power down after Vcc3\_3, or before Vcc3\_3 within 0.7 V.



2. The associated 3.3 V and 1.05 V supplies are assumed to power up or down 'together'. If the integrated VccSus1\_05 voltage regulator is **not** used: **a)** VccSus3\_3 must power up before VccSus1\_05 or after VccSus1\_05 within 0.7 V, **b)** VccSus1\_05 must power down before VccSus3\_3 or after VccSus3\_3 within 0.7 V.
3. The VccSus supplies must **never** be active while the VccRTC supply is inactive.
4. Vcc1\_5 must power up before V\_CPU\_IO or after V\_CPU\_IO within 0.7 V, **b)** V\_CPU\_IO must power down before Vcc1\_5 or after Vcc1\_5 within 0.7 V.
5. INIT# value determined by value of the CPU BISTEnable bit (Chipset Configuration Register Offset 3414h: bit 2).
6. The associated 3.3 V and 1.05 V supplies are assumed to power up or down 'together'. If the integrated VccLAN1\_05 voltage regulator is **not** used: **a)** VccLan3\_3 must power up before VccLan1\_05 or after VccLan1\_05 within 0.7 V, **b)** VccLan1\_05 must power down before VccLan3\_3 or after VccLan3\_3 within 0.7 V.
7. The associated 3.3 V and 1.05 V supplies are assumed to power up or down 'together'. If the integrated VccCL1\_05 voltage regulator is **not** used: **a)** VccCL3\_3 must power up before VccCL1\_05 or after VccCL1\_05 within 0.7 V, **b)** VccCL1\_05 must power down before VccCL3\_3 or after VccCL3\_3 within 0.7 V.
8. The associated 3.3 V and 1.5 V supplies are assumed to power up or down 'together'. If the integrated VccCL1\_5 voltage regulator is **not** used: **a)** VccCL3\_3 must power up before VccCL1\_5 or after VccCL1\_5 within 0.7 V, **b)** VccCL1\_5 must power down before VccCL3\_3 or after VccCL3\_3 within 0.7 V.
9. The associated 3.3 V and 1.5 V supplies are assumed to power up or down 'together'. If the integrated VccSus1\_5 voltage regulator is **not** used: **a)** VccSus3\_3 must power up before VccSus1\_5 or after VccSus1\_5 within 0.7 V, **b)** VccSus1\_5 must power down before VccSus3\_3 or after VccSus3\_3 within 0.7 V.
10. These transitions are clocked off the internal RTC. 1 RTC clock is approximately from 28.992  $\mu$ s to 32.044  $\mu$ s.
11. "VccGLANPLL inactive" is defined for this timing to be when VccGLANPLL drops to 1.425 V or less, as measured at the ICH8. This timing applies only to platforms using ICH8 integrated GbE LAN.



Table 173. Power Management Timings (Sheet 1 of 3)

Sym	Parameter	Min	Max	Units	Fig	Notes
t230	VccSus active to SLP_S5#, SLP_S4#, SLP_S3#, SUS_STAT#, PLTRST# and PCIRST# active	—	50	ns	40	
t231 t232	RSMRST# inactive to SUSCLK running, SLP_S5# inactive	—	110	ms	40	6,22
t233	SLP_S5# inactive to SLP_S4# inactive	See Note Below			40 49	8
t234	SLP_S4# inactive to SLP_S3# inactive	1	Note 16	RTCCLK	40 49	1
t250 (Mobile Only)	Processor I/F signals latched prior to STPCLK# active	0	—	—	44 46	9
t251 (Mobile Only)	Bus Master Idle to CPU_SLP# active	2.88	—	PCICLK	46	3, 11
t252 (Mobile Only)	CPUSLP# active to DPSLP# active	16	—	PCICLK	45 46	3
t253 (Mobile Only)	DPSLP# active to STP_CPU# active	1	1	PCICLK	45 46	3
t254 (Mobile Only)	STP_CPU# active to processor clock stopped	0	—	PCICLK	46	3, 10
t255 (Mobile Only)	STP_CPU# active to DPRSTP#, DPRSLPVR active	0	—	—	46	
t265 (Mobile Only)	Break Event to DPRSTP#, DPRSLPVR inactive (C4 Exit)	1.5	1.8	µs	46	12
t266 (Mobile Only)	DPRSLPVR, DPRSTP# inactive to STP_CPU# inactive and CPU Vcc ramped	Programmable. See D31:F0:AA, bits 3:2		µs	46	
t267 (Mobile Only)	Break Event to STP_CPU# inactive (C3 Exit)	6	Note 14	PCICLK	45	3, 13, 14
t268 (Mobile Only)	STP_CPU# inactive to processor clock running	0	3	PCICLK	46	3, 10
t269 (Mobile Only)	STP_CPU# inactive to DPSLP# inactive	1	1	PCICLK	45 46	3, 7
t270 (Mobile Only)	DPSLP# inactive to CPU_SLP# inactive	Programmable. See D31:F0:AAh, bits 1:0		µs	45 46	7
t271 (Desktop Only)	S1 Wake Event to CPUSLP# inactive	1	25	PCICLK	41	3
t272 (Mobile Only)	CPUSLP# inactive to STPCLK# inactive	0	—	µs	46	
t273 (Mobile Only)	Break Event to STPCLK# inactive (C2 Exit)	0	—	ns	44	
t274 (Mobile Only)	STPCLK# inactive to processor I/F signals unlatched	8	9	PCICLK	44 46	3, 9





Table 173. Power Management Timings (Sheet 2 of 3)

Sym	Parameter	Min	Max	Units	Fig	Notes
t280	STPCLK# active to DMI Message	0	—	PCICLK	41 42 43	2
t281 (Desktop Only)	DMI Message to CPUSLP# active	60	63	PCICLK	41	3
t283	DMI Message to SUS_STAT# active	2		RTCCLK	42 43	1
t284	SUS_STAT# active to PLTRST#, PCIRST# active (Desktop Only)	7	17	RTCCLK	42	1
t285 (Mobile Only)	SUS_STAT# active to STP_PCI# active	2	10	RTCCLK	43	1
t286 (Mobile Only)	STP_PCI# active to PLTRST# and PCIRST# active	5	7	RTCCLK	43	1
t287	PLTRST#, PCIRST# active to SLP_S3# active	1	2	RTCCLK	42 43	1
t288 (Mobile Only)	SLP_S3# active to PWROK, VRMPWRGD inactive	0	—	ms	43	4
t289 (Desktop Only)	SLP_S3# active to PWROK, VRMPWRGD inactive	0	—	ms	42	4
t290 (Mobile Only)	PWROK, VRMPWRGD inactive to Vcc supplies inactive	20	—	ns	43 53	27
t291	SLP_S3# active to SLP_S4# active	1	2	RTCCLK	42 43	1
t294 (Desktop Only)	PWROK, VRMPWRGD inactive to Vcc supplies inactive	20	—	ns	42 52	23, 25
t295	SLP_S4# active to SLP_S5# active	1	2	RTCCLK	42 43	1, 5
t296	Wake Event to SLP_S5# inactive	1	10	RTCCLK	42 43	1
t297	SLP_S5# inactive to SLP_S4# inactive	See Note Below			42 43 49 50 51	8
t298	SLP_S4# inactive to SLP_S3# inactive	1	Note 16	RTCCLK	42 43 49 50 51	1
t299	S4 Wake Event to SLP_S4# inactive (S4 Wake)	See Note Below			42 43	8
t300	S3 Wake Event to SLP_S3# inactive (S3 Wake)	0	small as possible	RTCCLK	42 43	1



Table 173. Power Management Timings (Sheet 3 of 3)

Sym	Parameter	Min	Max	Units	Fig	Notes
t301 (Desktop Only)	CPUSLP# inactive to STPCLK# inactive	8	—	PCICLK	41	
t302	SLP_M# inactive to SLP_S3# inactive	—	±10	ns		
t303	SLP_S4# inactive to SLP_M# inactive when AMT enabled	—	±10	ns		15
t304	RSMRST# deassertion to LAN_RST# deassertion	0		ms		17
t305	LAN Power Rails active to LAN_RST# deassertion	1	—	ms		18
t306	LAN_RST# assertion to PWROK assertion	0	—	ms		
t307	SLP_S3# active to Vcc supplies inactive	5	—	us	42	24, 25
<b>Other Timings</b>						
t310	THRMTRIP# active to SLP_S3#, SLP_S4#, SLP_S5# active	—	3	PCI CLK		
t311	RSMRST# rising edge transition from 20% to 80%		50	us		
t312	RSMRST# falling edge transition					21
t313	SLP_M# active to RSMRST# active	500	—	us	27 34	26

**NOTES:**

- These transitions are clocked off the internal RTC. 1 RTC clock is approximately from 28.992 μs to 32.044 μs.
- The ICH8 STPCLK# assertion will trigger the processor to send a stop grant acknowledge cycle. The timing for this cycle getting to the ICH8 is dependant on the processor and the memory controller.
- These transitions are clocked off the 33 MHz PCICLK. 1 PCICLK is approximately 30 ns.
- The ICH8 has no maximum timing requirement for this transition. It is up to the system designer to determine if the SLP\_S3#, SLP\_S4# and SLP\_S5# signals are used to control the power planes.
- If the transition to S5 is due to Power Button Override, SLP\_S3#, SLP\_S4# and SLP\_S5# are asserted together similar to timing t287 (PCIRST# active to SLP\_S3# active).
- If there is no RTC battery in the system, so VccRTC and the VccSus supplies come up together, the delay from RTCRST# and RSMRST# inactive to SUSCLK toggling may be as much as 2.5 s.
- This value is programmable in multiples of 1024 PCI CLKs. Maximum is 8192 PCI CLKs (245.6 μs).
- The Minimum/Maximum times depend on the programming of the "SLP\_S4# Minimum Assertion Width" and the "SLP\_S4# Assertion Stretch Enable bits (D31:F0:A4h bits 5:3)". Note that this does not apply for synchronous SMIs.
- This is a clock generator specification
- If the (G)MCH does not have the CPUSLP# signal, then the minimum value can be 0 μs.
- This is non-zero to enforce the minimum assert time for DPRSLPVR. If the minimum assert time for DPRSLPVR has been met, then this is permitted to be 0.
- This is non-zero to enforce the minimum assert time for STP\_CPU#. If the minimum assert time for STP\_CPU# has been met, then this is permitted to be 0.
- This value should be at most a few clocks greater than the minimum.
- When AMT enabled, S4\_STATE# mimics SLP\_S4# (Desktop Only).



16. For t234 and t298, if Intel Manageability Engine firmware is installed in the system, the Max value of t234 and t298 is 99 ms. Without the installation of the firmware, the Max value is 4 RTC clocks.
17. RSMRST# must deassert before or equal to LAN\_RST#
18. Measured from VccLAN3\_3 or VccLAN1\_05 pwr within voltage spec (which ever is later in time) to LAN\_RST# =  $(V_{ih} + V_{il})/2$ . It is acceptable to use an RC circuit sourced from VccLAN3\_3 to create LAN\_RST#. The rising edge of LAN\_RST# needs to be a clean, monotonic edge for frequency content below 10MHz.
19. If Integrated LAN is supported, LAN\_RST# must be deasserted before or equal to PWROK assertion.
20. If Integrated LAN is not supported, LAN\_RST# should be tied to ground and must never deassert
21. RSMRST# falling edge must transition to 0.8V or less before VccSus3\_3 drops to 2.1V
22. If bit 0 of Section 9.8.1.3 is set to a 1, SLP\_S5# will not be de-asserted until a wake event is detected. If bit 0 is set to 0, SLP\_S5# will deassert within the specification listed in the table.
23. t294 applies during S0 to G3 transitions only. The timing is not applied to V5REF. V5REF timings are bonded by power sequencing.
24. t307 applies during S0 to Sx transitions.
25. A Vcc supply is inactive when the voltage is below the min value specified in Table 155.
26. t313 is not applicable for non-Intel AMT systems. t313 applies to Mobile Intel AMT systems only in case of S0/M0 to S4/S4Moff (w/o WOL).
27. t290 is also applied when the system transitions from S0 to G3.

## 23.5 Timing Diagrams

Figure 22. Clock Timing

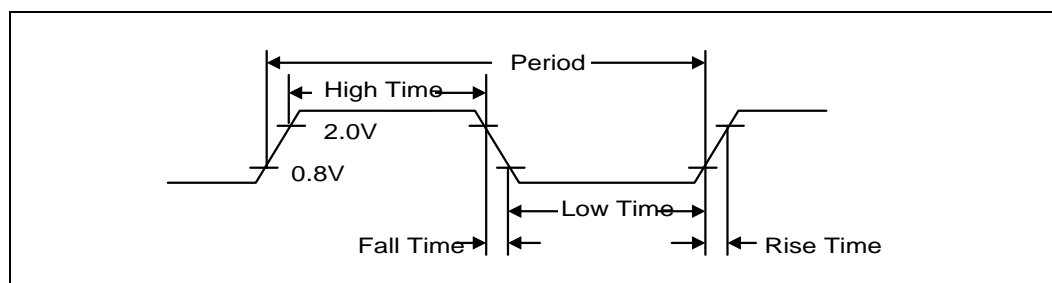


Figure 23. Valid Delay from Rising Clock Edge

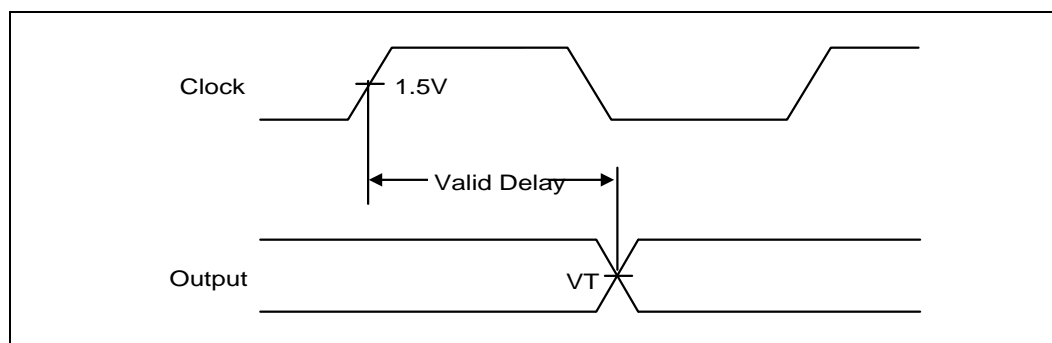


Figure 24. Setup and Hold Times

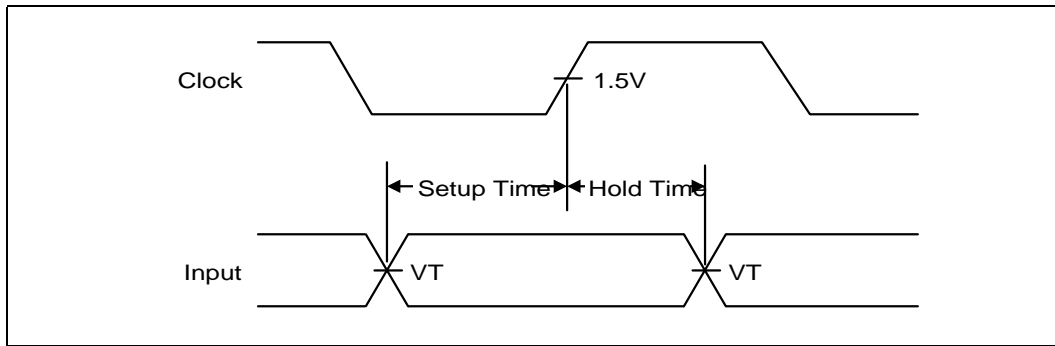


Figure 25. Float Delay

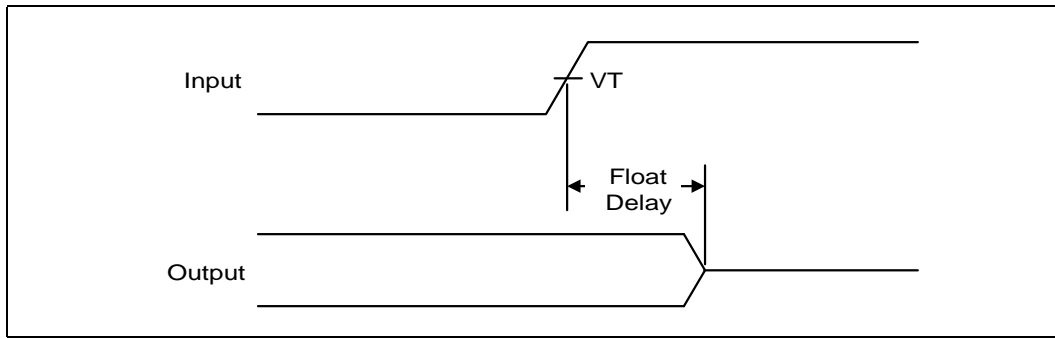


Figure 26. Pulse Width

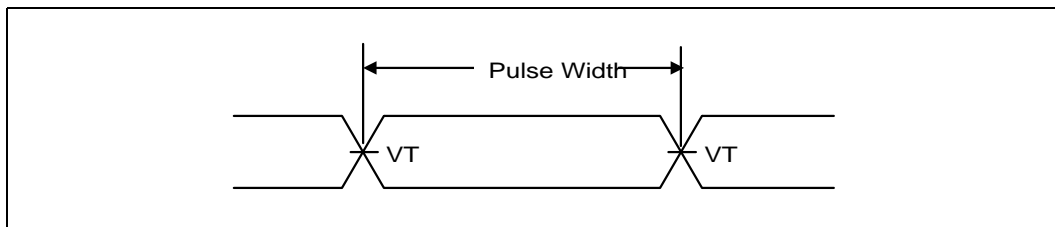


Figure 27. Output Enable Delay

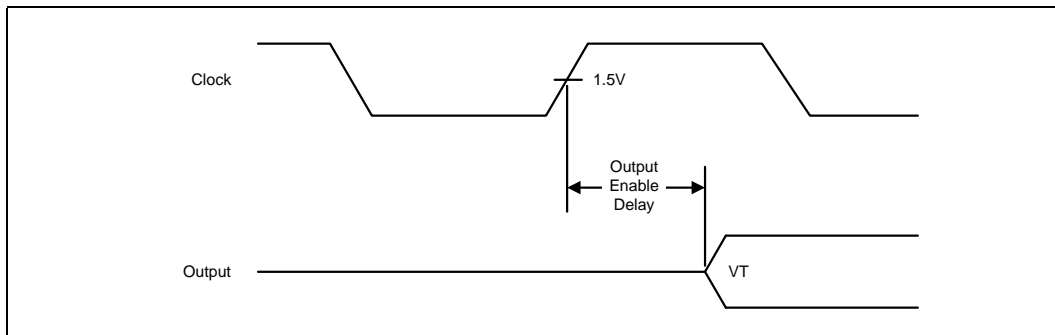




Figure 28. IDE PIO Mode (Mobile Only)

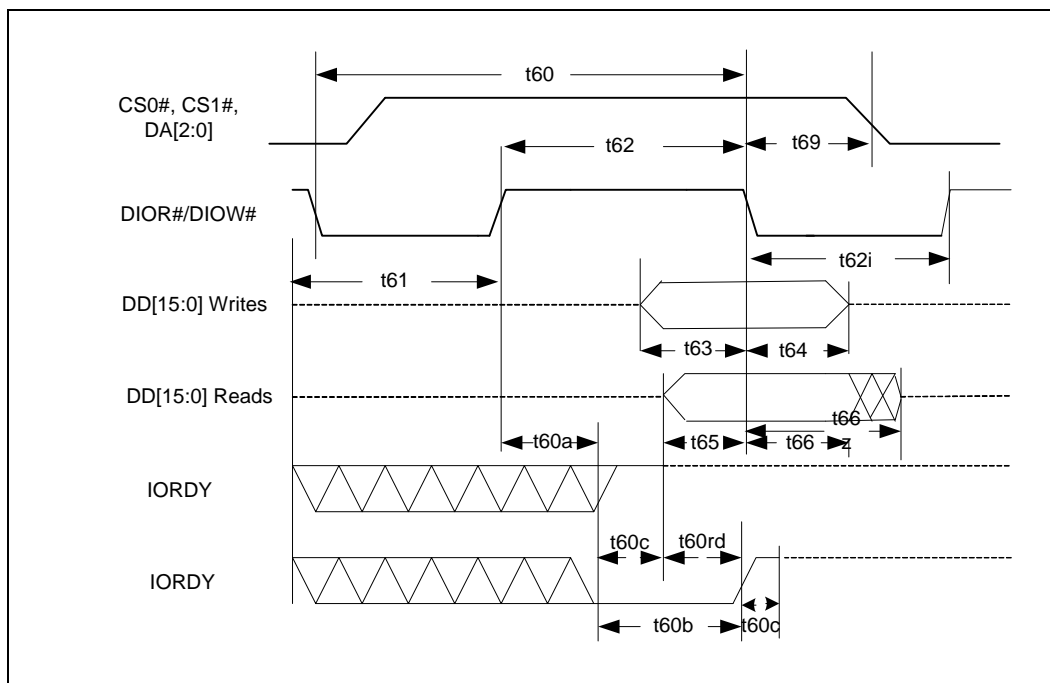


Figure 29. IDE Multiword DMA (Mobile Only)

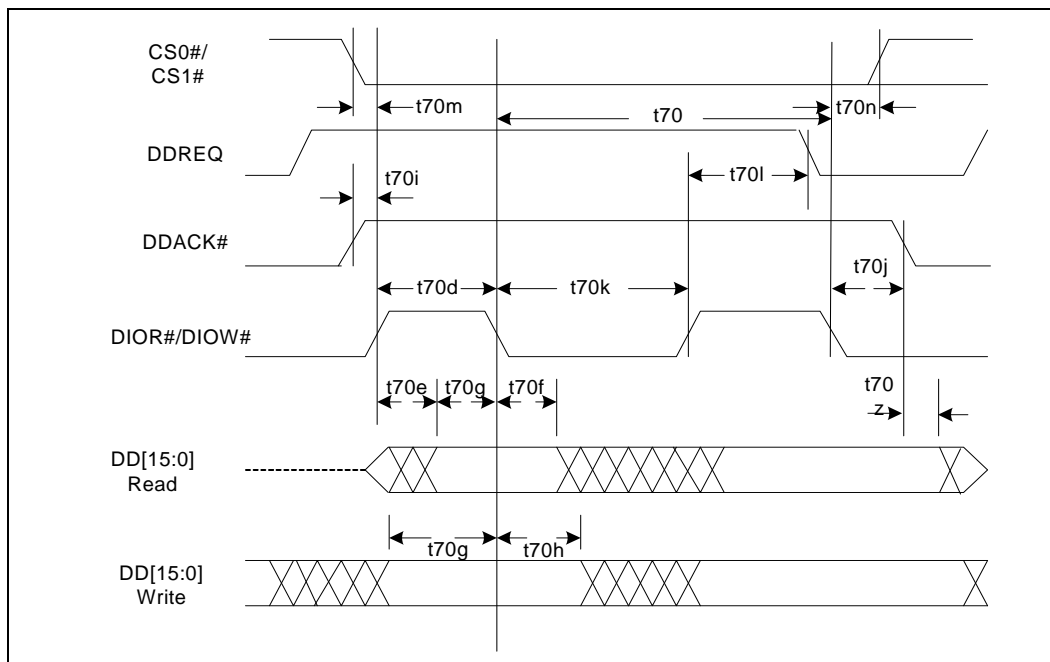


Figure 30. Ultra ATA Mode (Drive Initiating a Burst Read) (Mobile Only)

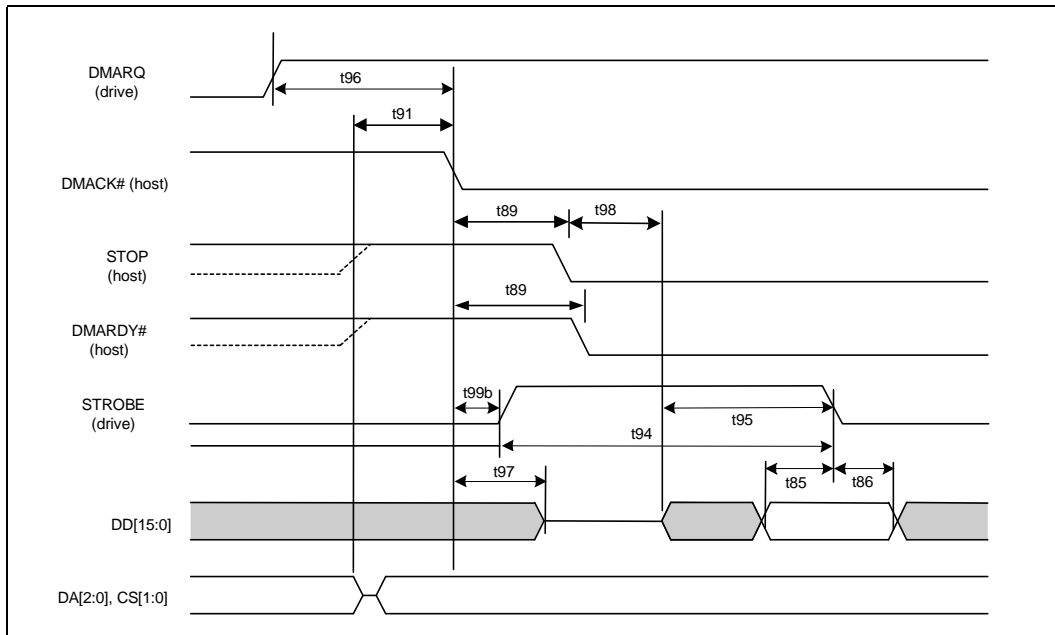
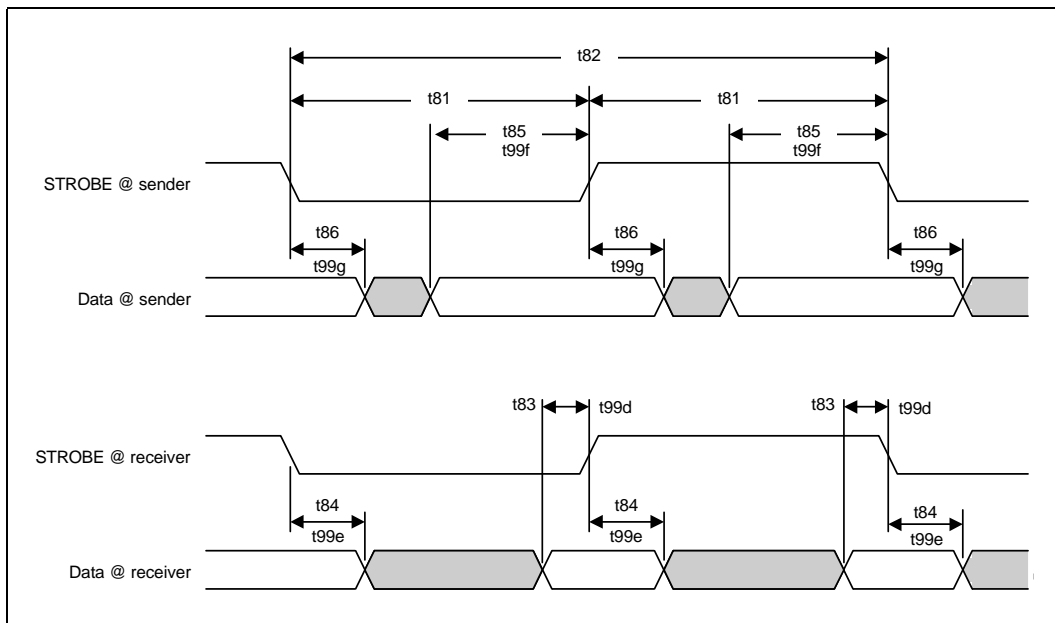
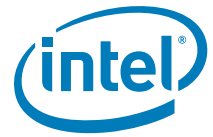
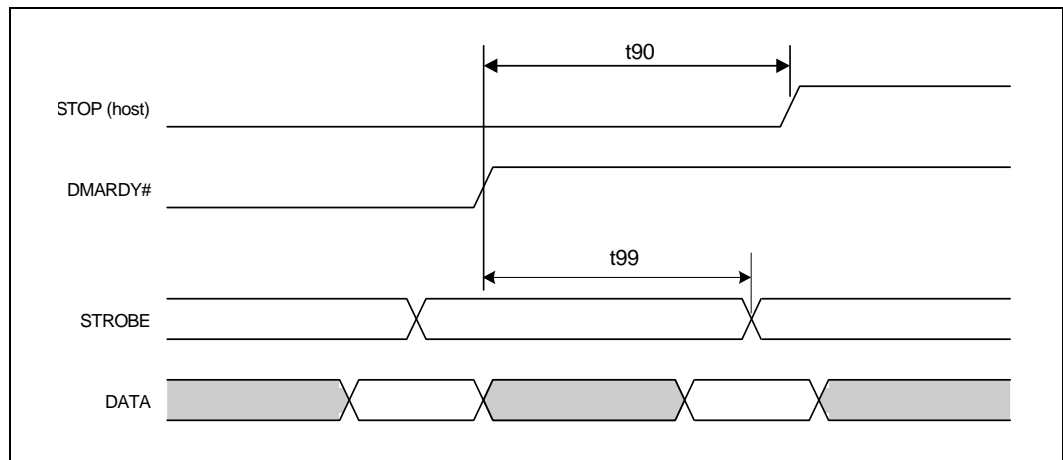


Figure 31. Ultra ATA Mode (Sustained Burst) (Mobile Only)





**Figure 32. Ultra ATA Mode (Pausing a DMA Burst) (Mobile Only)**



**Figure 33. Ultra ATA Mode (Terminating a DMA Burst) (Mobile Only)**

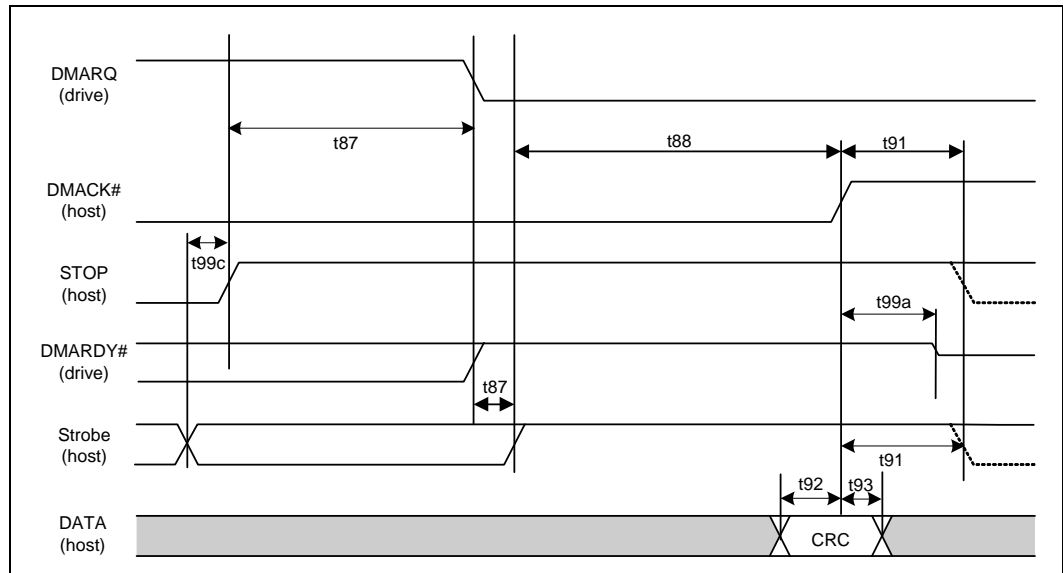


Figure 34. USB Rise and Fall Times

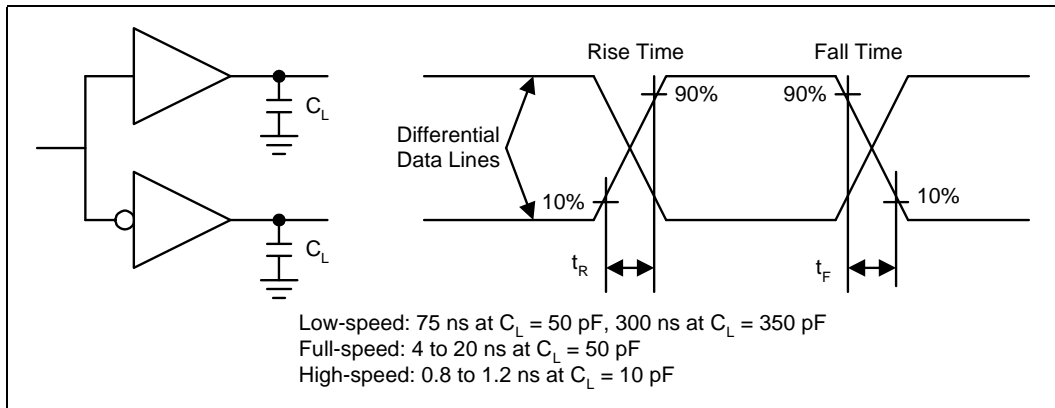


Figure 35. USB Jitter

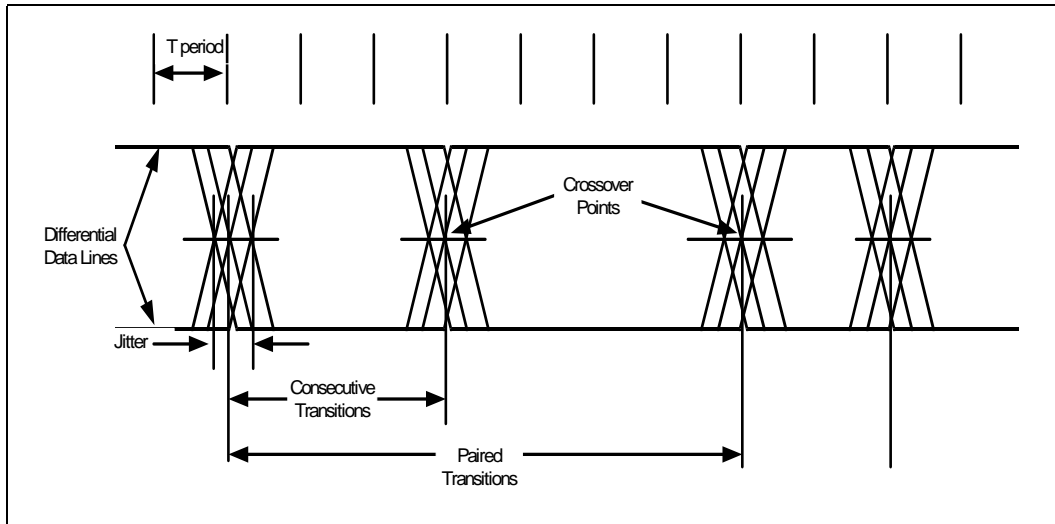


Figure 36. USB EOP Width

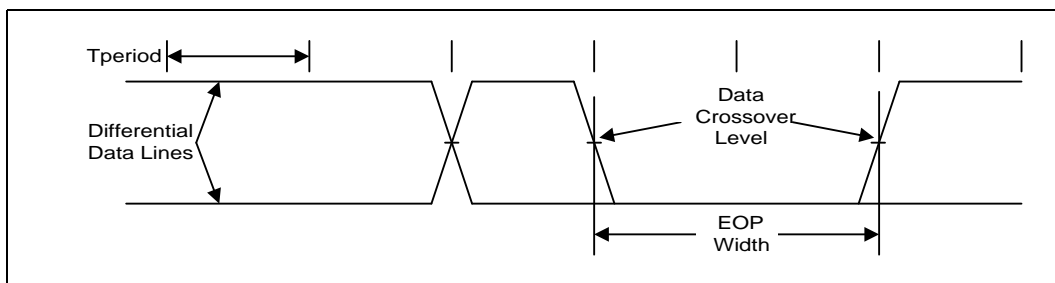






Figure 37. SMBus Transaction

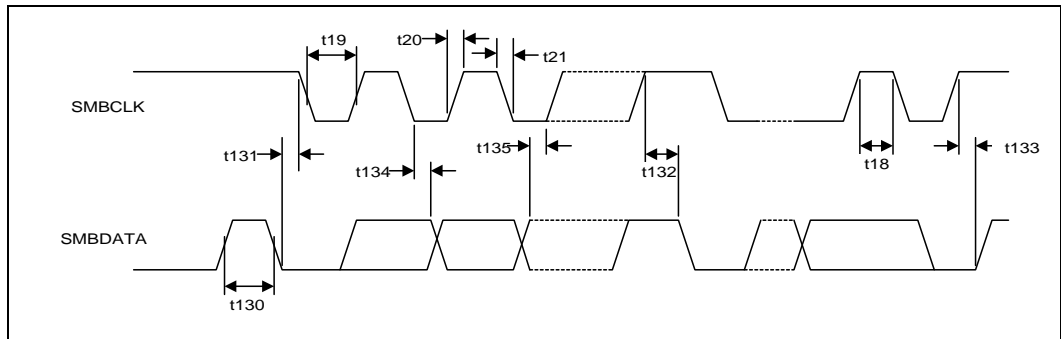


Figure 38. SMBus Timeout

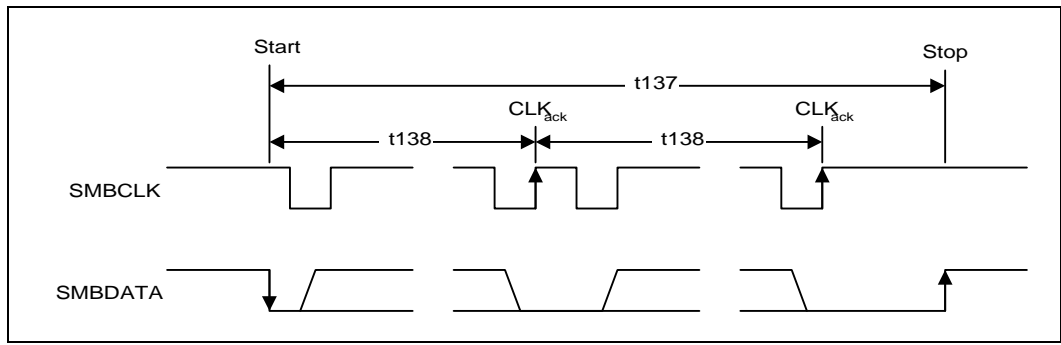
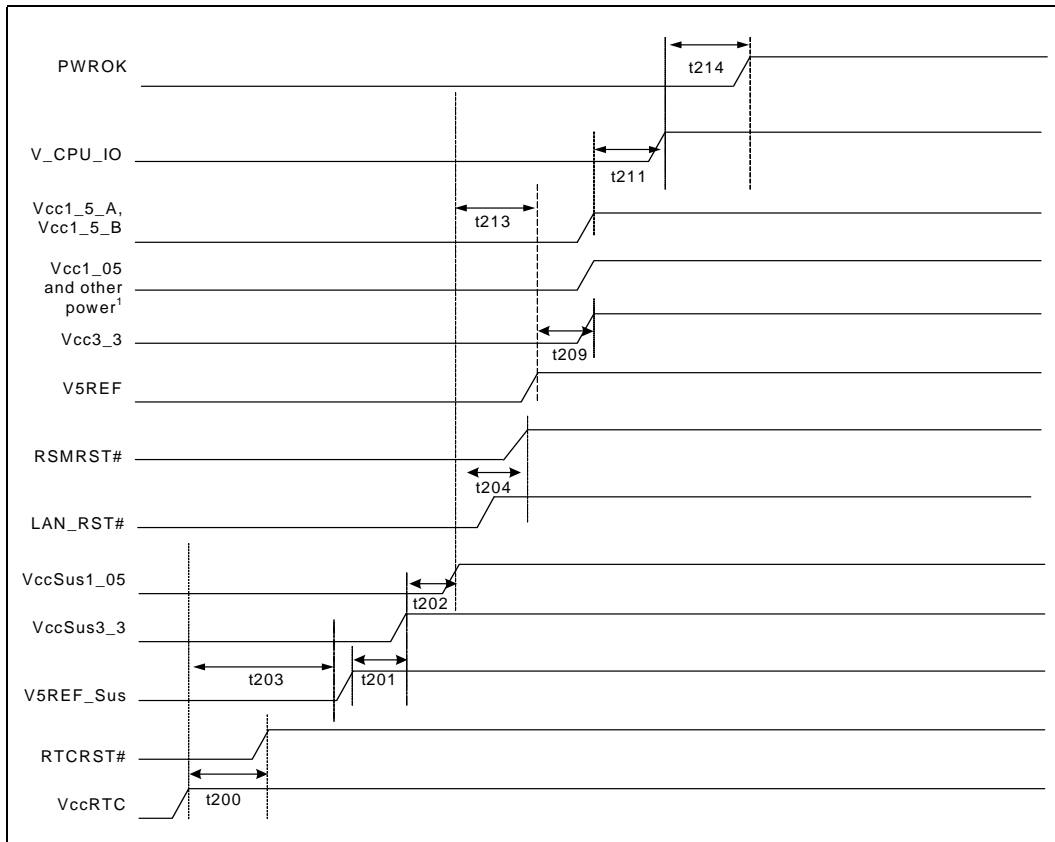


Figure 39. Power Sequencing and Reset Signal Timings

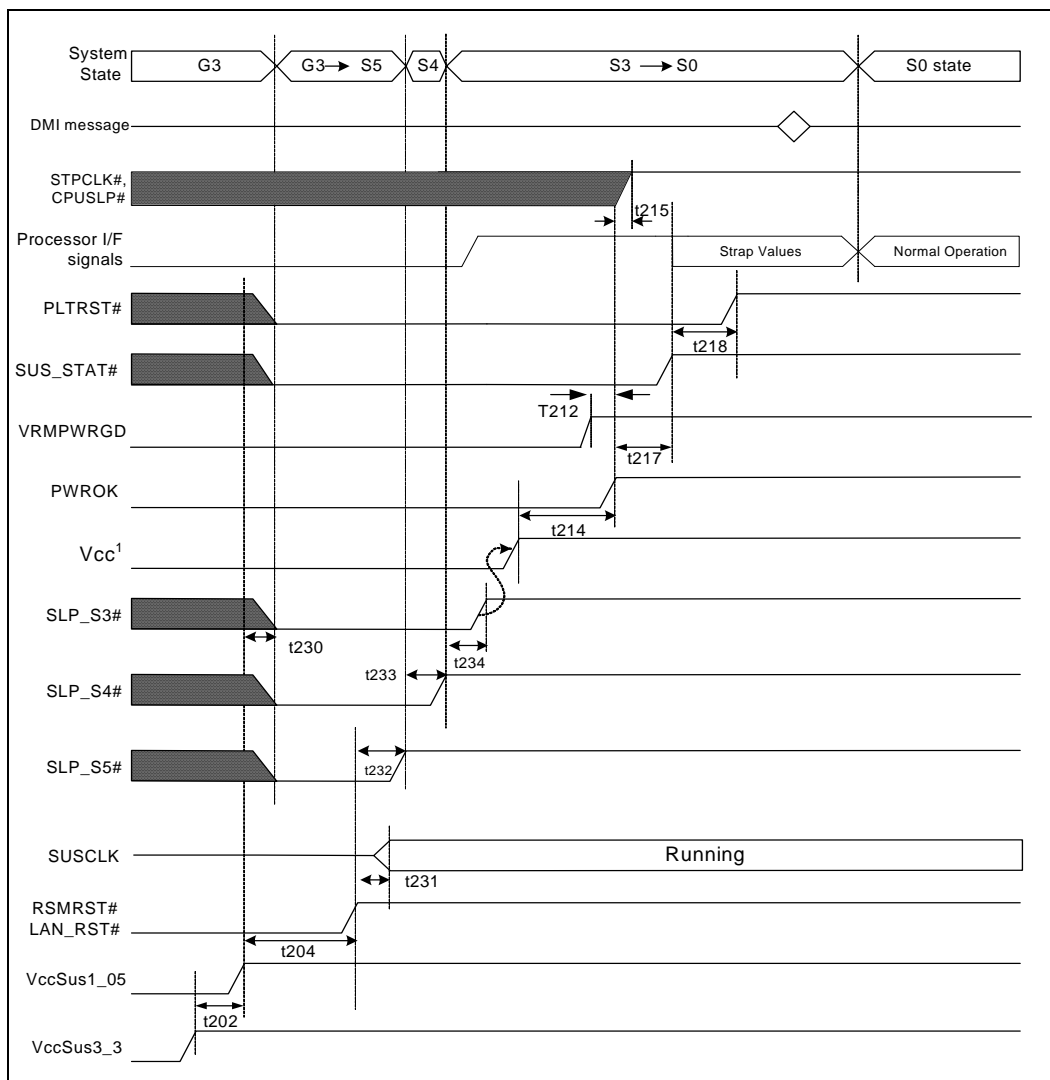


**NOTES:**

1. Other power includes  $V_{ccUSBPLL}$ ,  $V_{ccDMIPLL}$ , and  $V_{ccSATAPLL}$ . All of these power signals must independently meet the timings shown in the figure. There are no timing interdependencies between  $V_{cc1\_05}$  and these other power signals. There are also no timing interdependencies for these power signals, including  $V_{cc1\_05}$ , to  $V_{cc3\_3}$  and  $V_{cc1\_5\_A}/V_{cc1\_5\_B}$ .
2.  $PWROK$  must not glitch, even if  $RSMRST\#$  is asserted.



Figure 40. G3 (Mechanical Off) to S0 Timings



**NOTES:**

1. Vcc includes Vcc1\_5\_A, Vcc1\_5\_B, Vcc3\_3, Vcc1\_05, VccUSBPLL, VccDMIPLL, VccSATAPLL, and V5REF.

Figure 41. S0 to S1 to S0 Timing

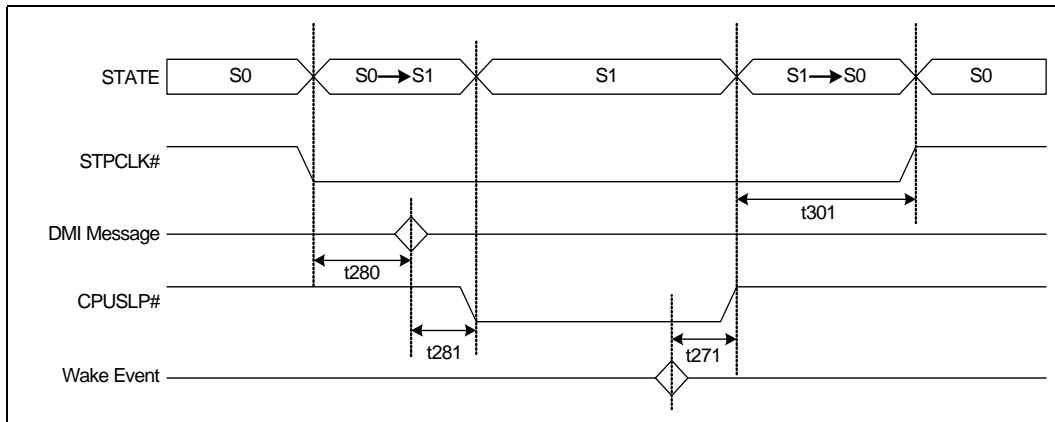
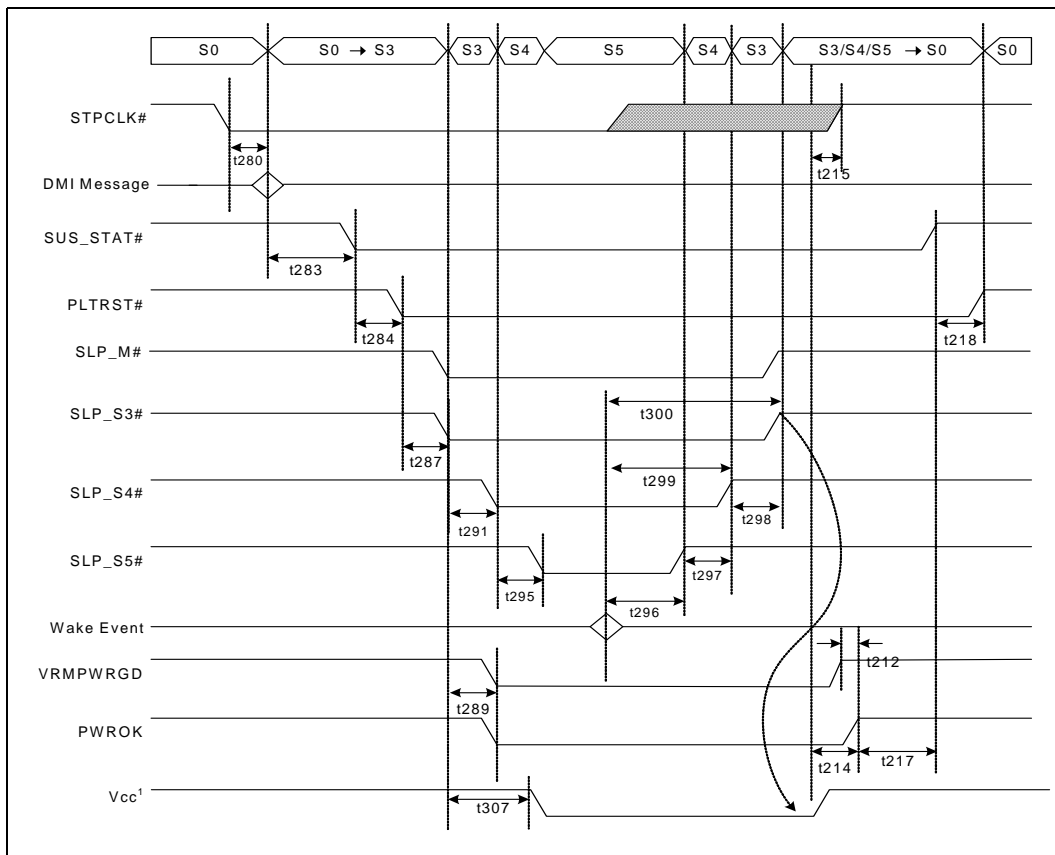


Figure 42. S0 to S5 to S0 Timings, S3 (Desktop Only)

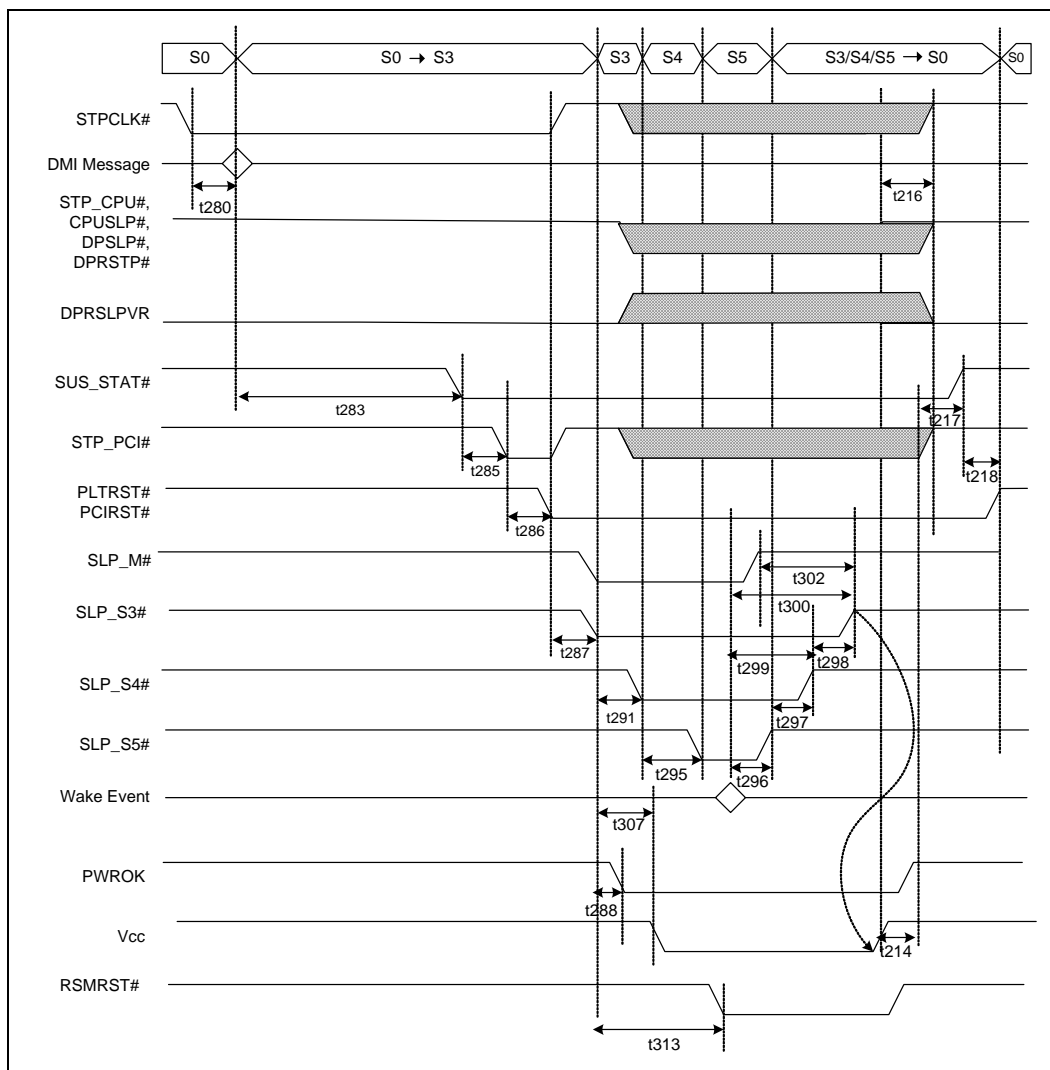


**NOTES:**

1. Vcc includes Vcc1\_5\_A, Vcc1\_5\_B, Vcc3\_3, Vcc1\_05, VccUSBPLL, VccDMIPLL, VccSATAPLL, and V5REF.



Figure 43. S0 to S5 to S0 Timings, S3 (Mobile Only)



NOTE: t290 is also applied when the system transitions from S0 to G3.

Figure 44. C0 to C2 to C0 Timings (Mobile Only)

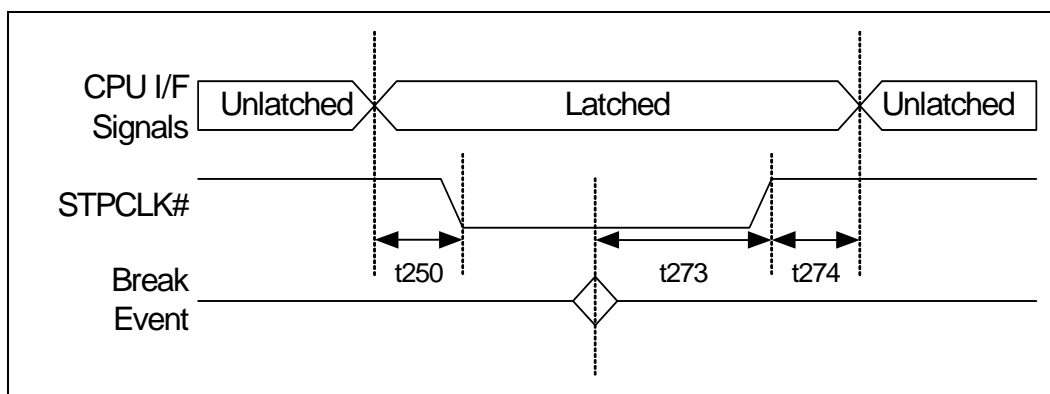


Figure 45. C0 to C3 to C0 Timings (Mobile Only)

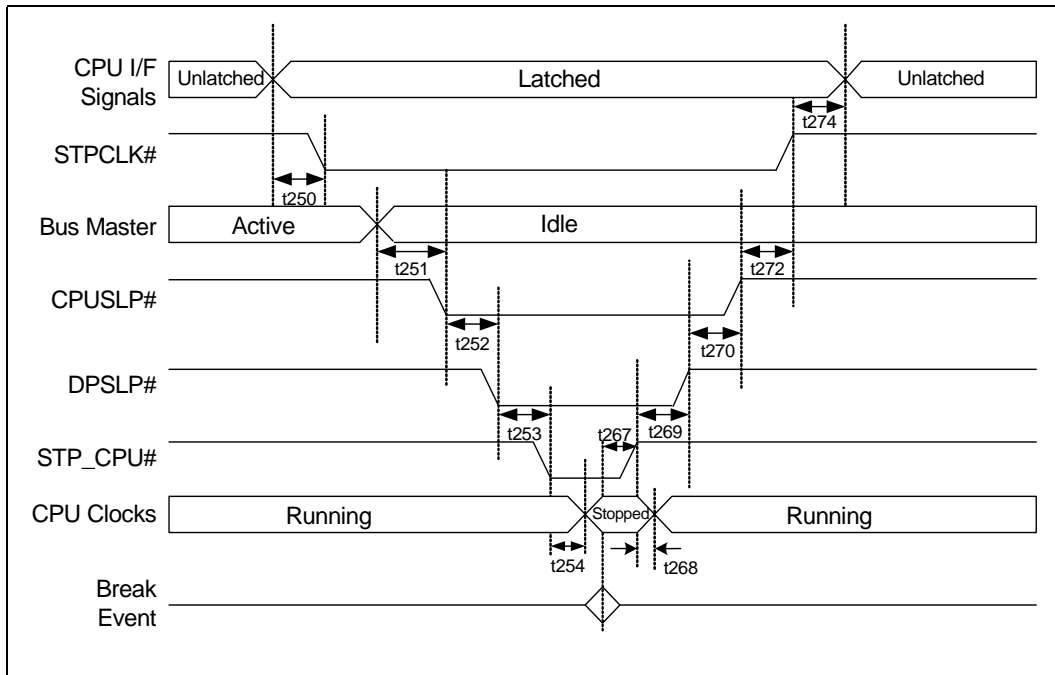
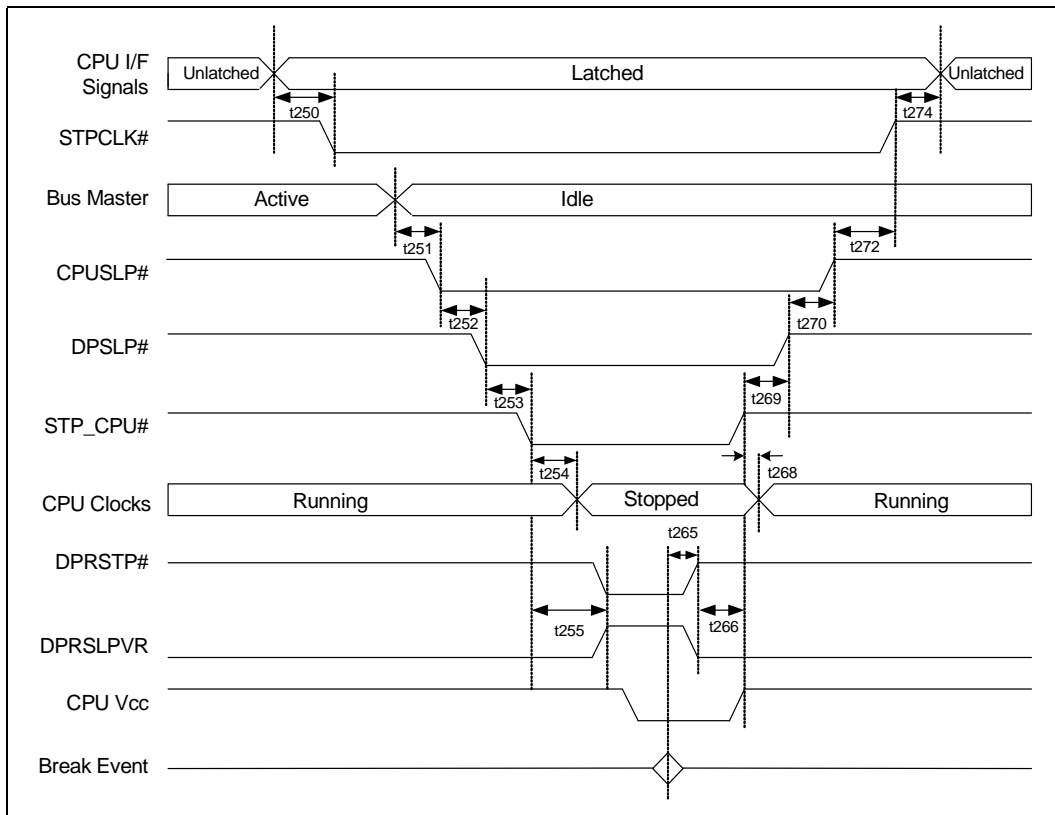


Figure 46. C0 to C4 to C0 Timings (Mobile Only)



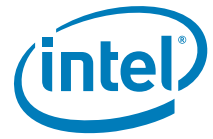


Figure 47. Intel® High Definition Audio Input and Output Timings

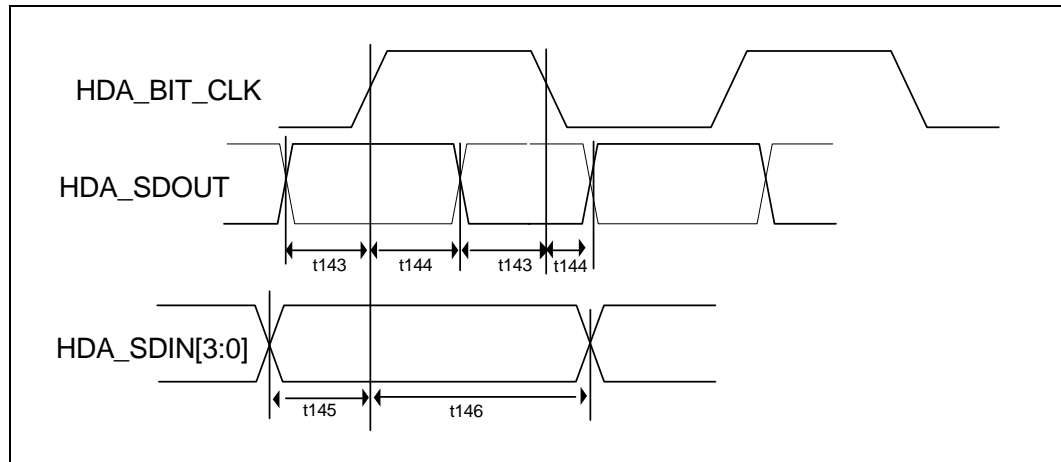


Figure 48. SPI Timings

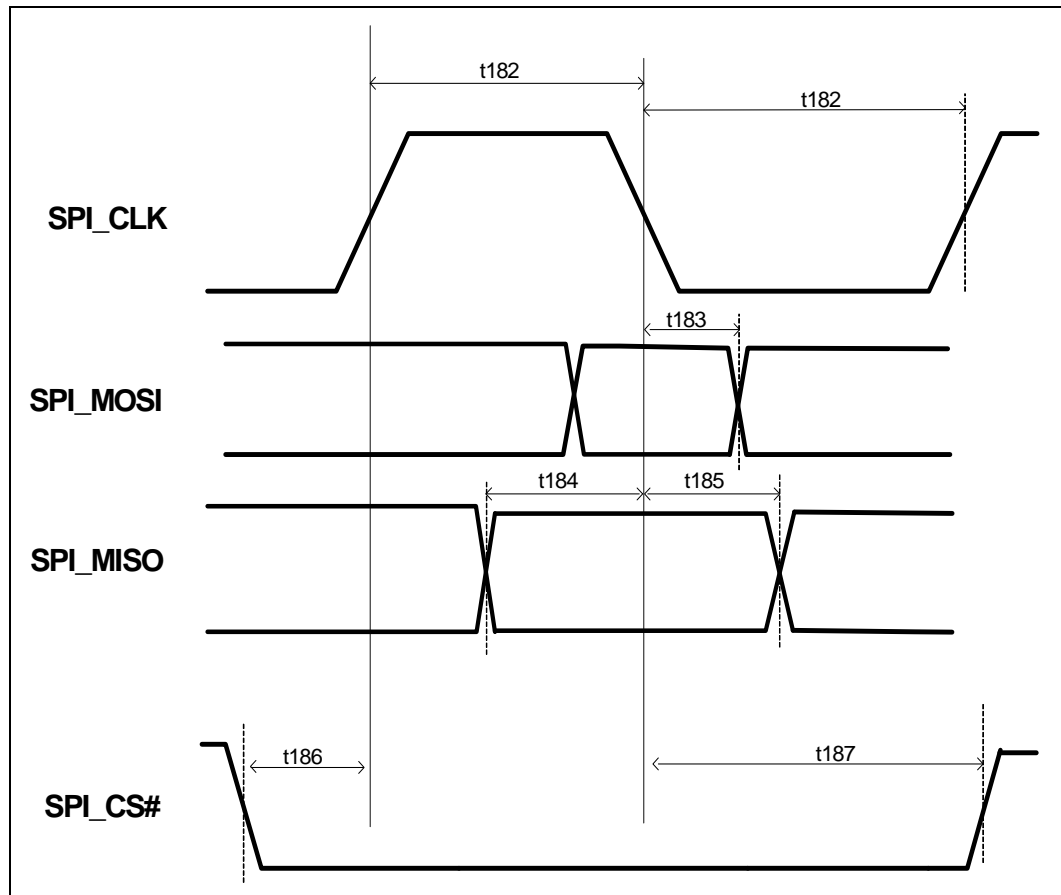


Figure 49. Sleep control signal relationship – Host boots and ME off

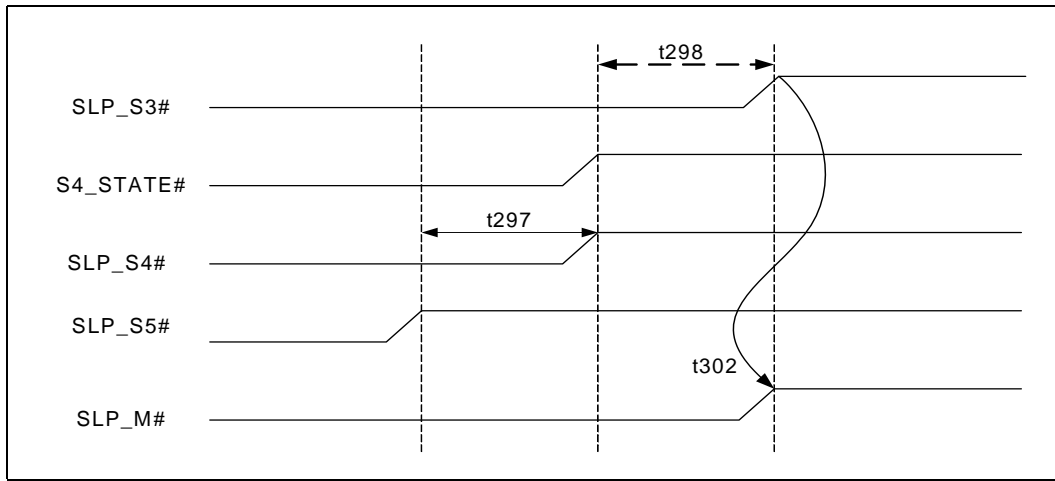
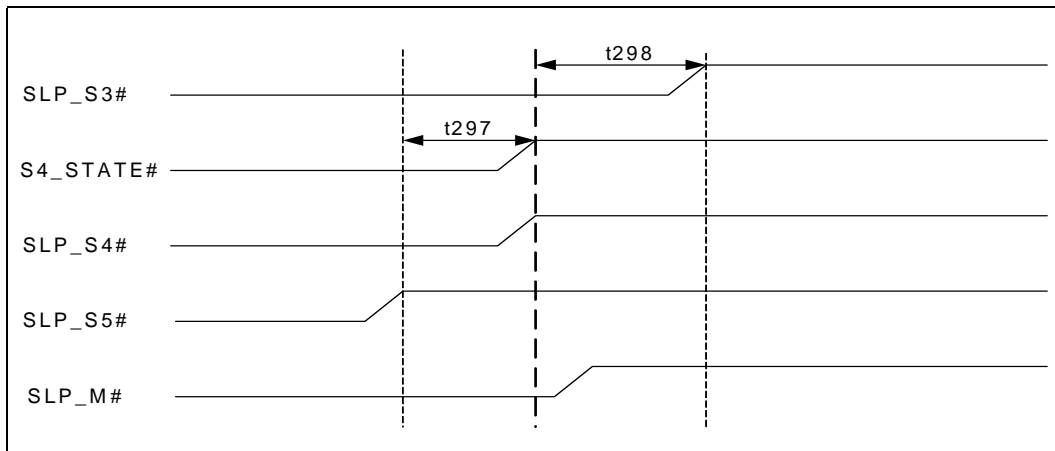


Figure 50. Sleep control signal relationship – Host and ME boot after G3

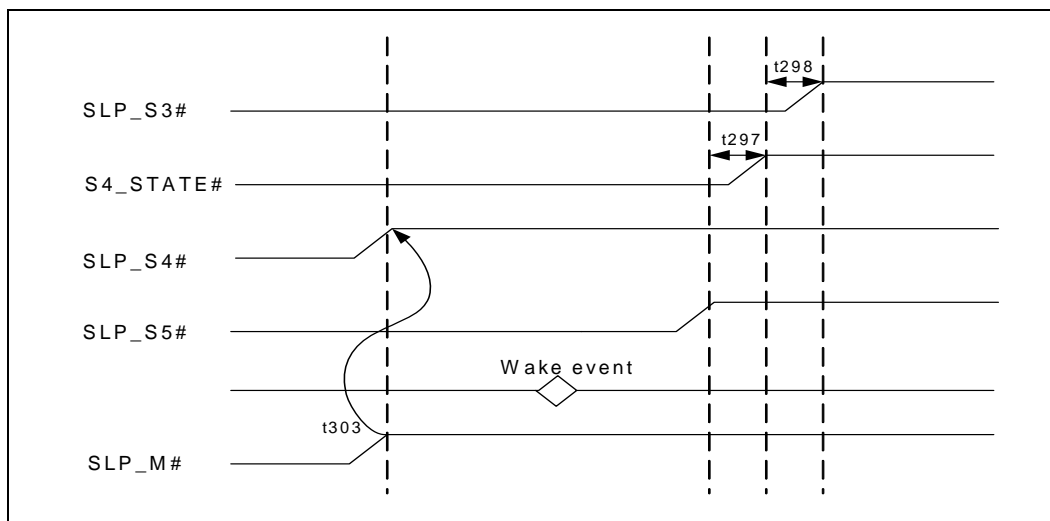


**NOTE:** When both the host and ME boot after G3, SLP\_M# does not have any timing dependency on other sleep control signals. SLP\_M# will be de-asserted some time between SLP\_S5# de-assertion and SLP\_S3# de-assertion.

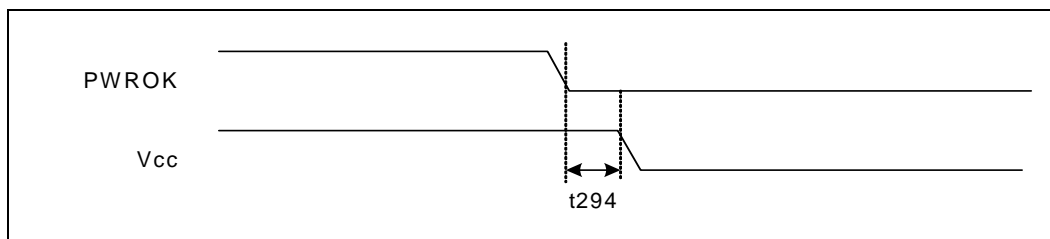




**Figure 51. Sleep Control Signal Relationship – Host stays in S5 and ME boots after G3**

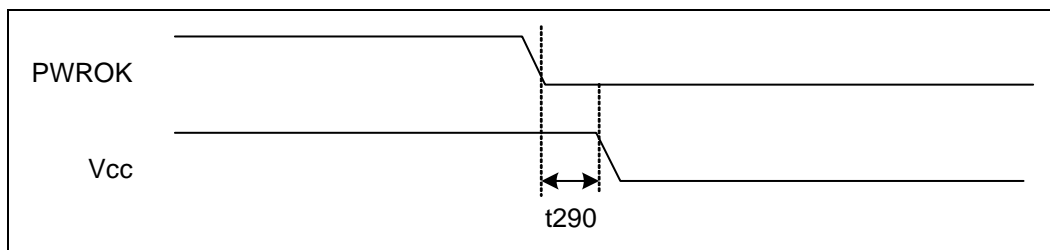


**Figure 52. S0 to G3 PWROK and Vcc Timing**



**NOTE:** Vcc includes Vcc1\_5\_A, Vcc1\_5\_B, Vcc3\_3, Vcc1\_05, VccUSBPLL, VccDMIPLL, and VccSATAPLL.

**Figure 53. S0 to G3 Timings (Mobile Only)**



**NOTE:**

1. Vcc includes Vcc1\_5\_A, Vcc1\_5\_B, Vcc3\_3, Vcc1\_05, VccUSBPLL, VccDMIPLL, and VccSATAPLL.

§ §





# 24 Package Information

## 24.1 Package Dimensions (Desktop Only)

Figure 54, Figure 55, and Figure 56. show the package information for the 82801HB ICH8, 82801HR ICH8R, 82801HDH ICH8DH, and 82801HDO ICH8DO components.

**Note:** Unless otherwise specified, all dimensions are in millimeters

**Figure 54. Package Dimensions (Top View) (Desktop Only)**

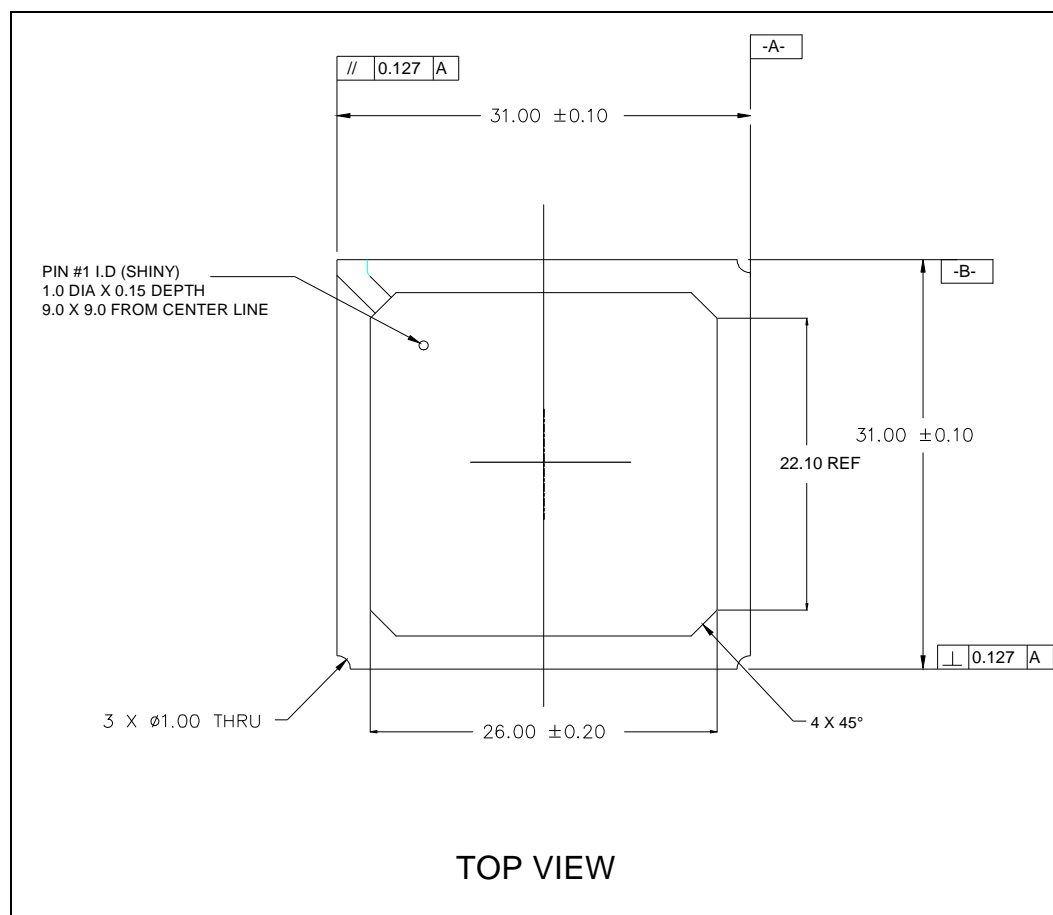


Figure 55. Package Dimensions (Bottom View) (Desktop Only)

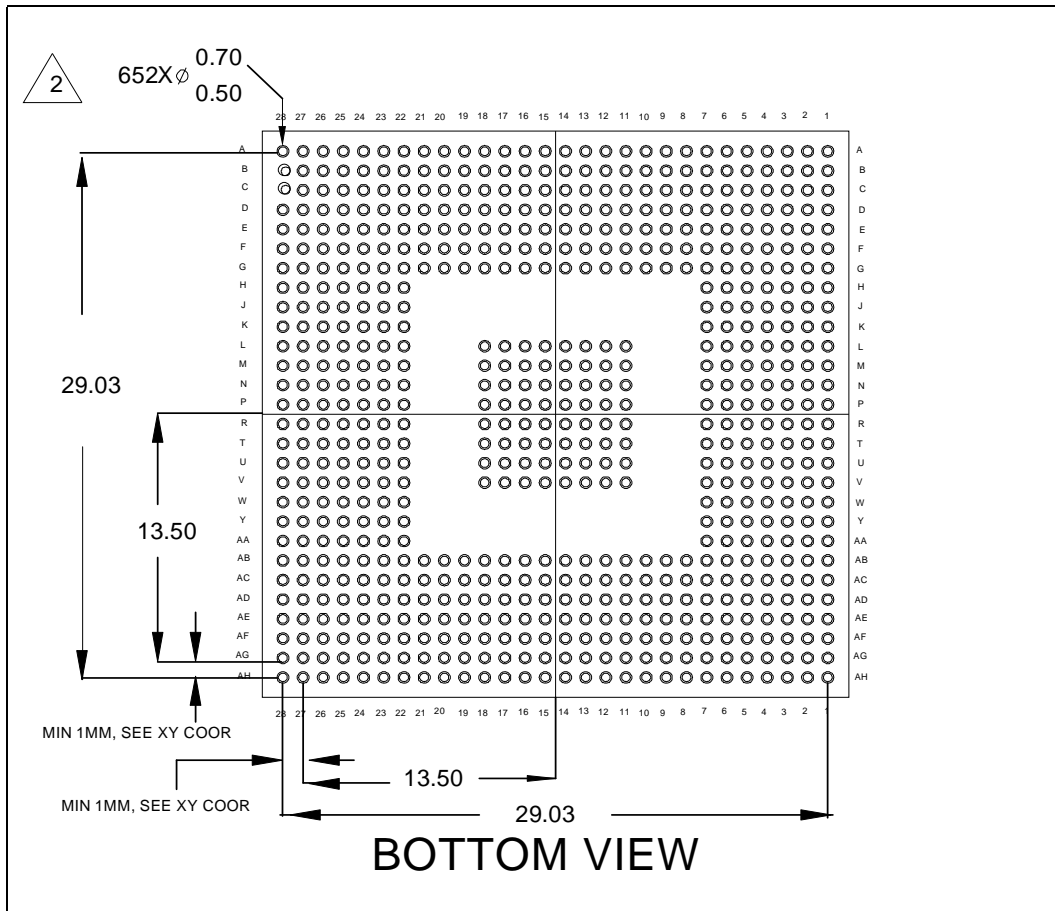
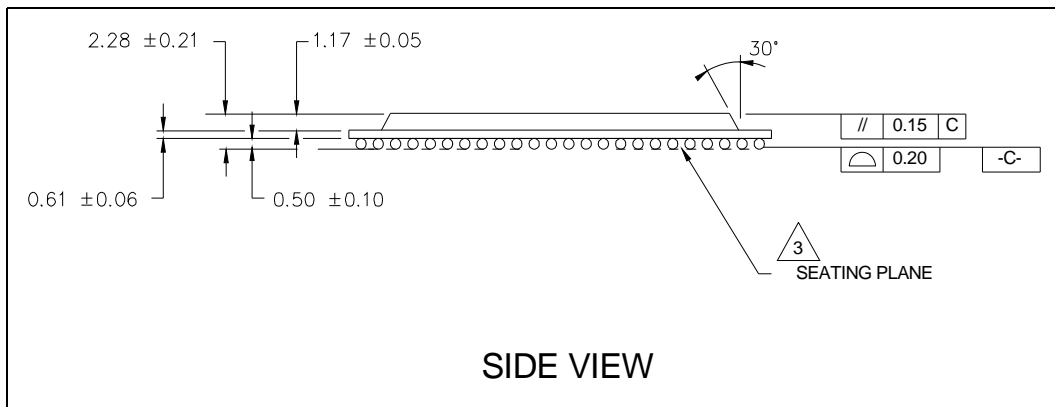


Figure 56. Package Dimensions (Side View) (Desktop Only)





## 24.2 Package Dimensions (Mobile Only)

Figure 57, Figure 58, and Figure 59 show the top view ballout for the 82801HBM ICH8M and 82801HEM ICH8M-E components.

**Note:** Unless otherwise specified, all dimensions are in millimeters.

Figure 57. Package Dimensions (Top View) (Mobile Only)

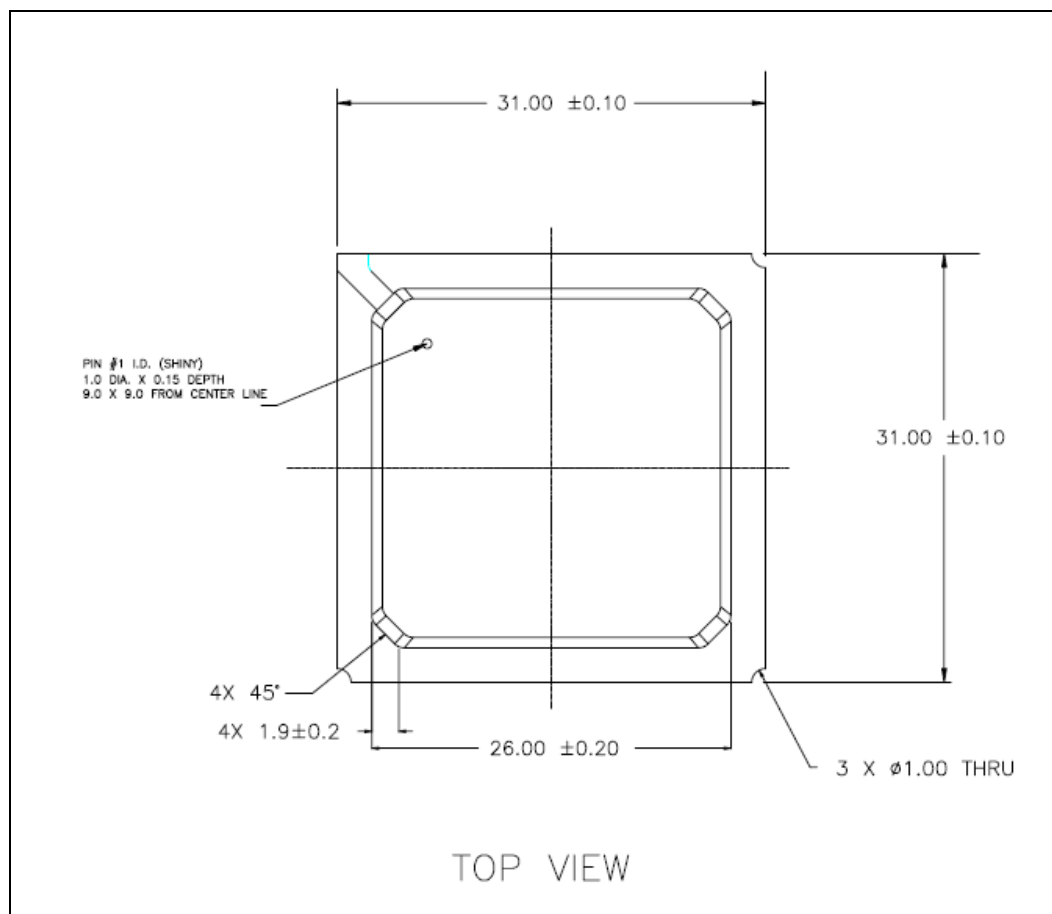


Figure 58. Package Dimensions (Bottom View) (Mobile Only)

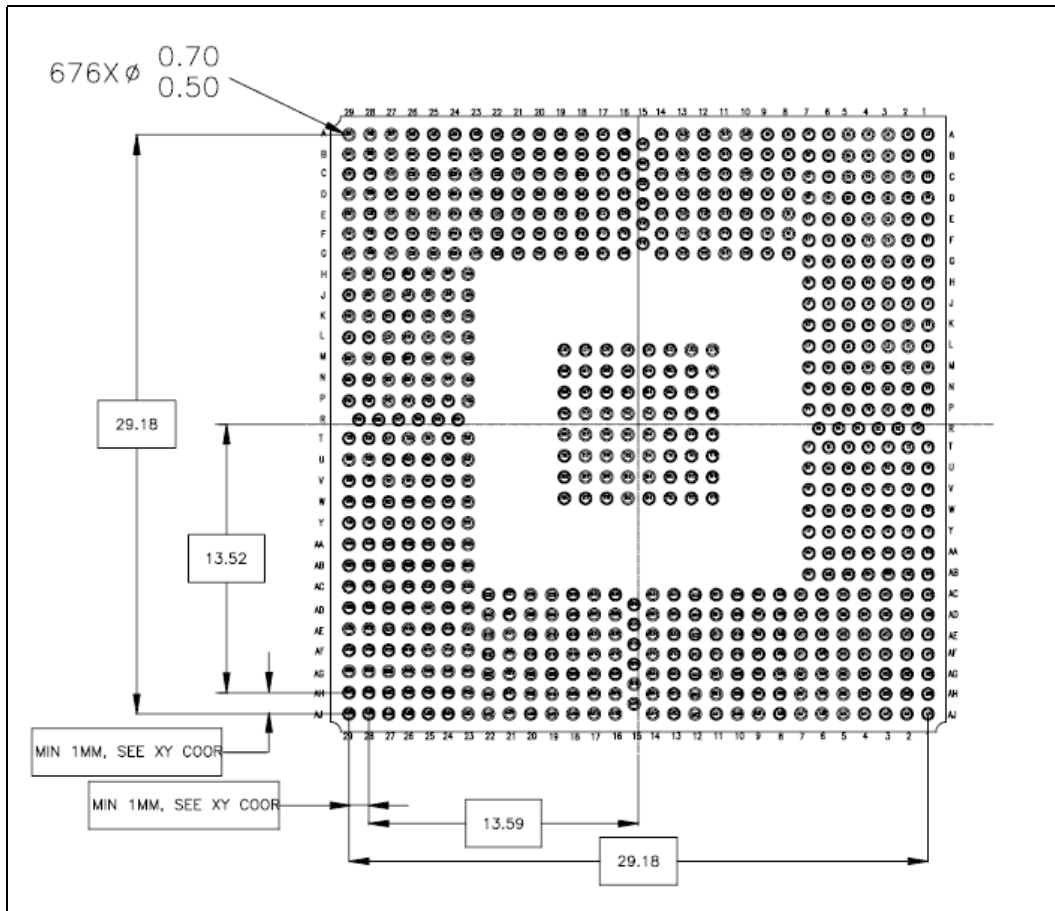
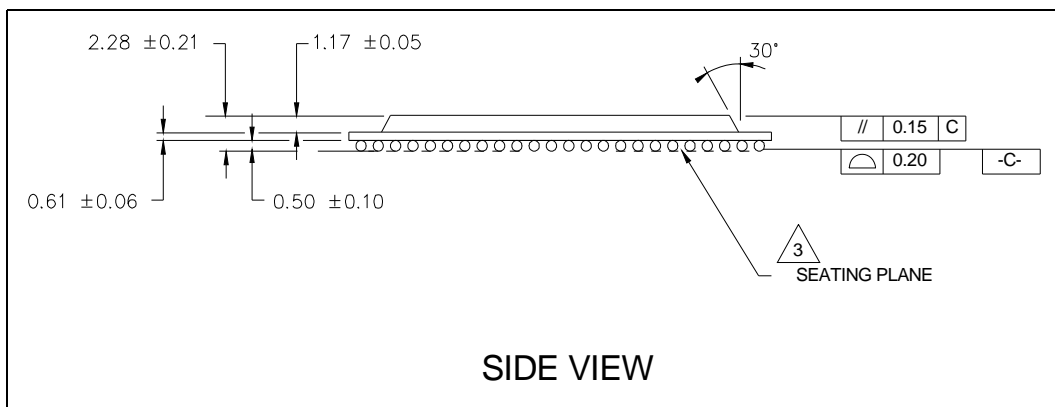


Figure 59. Package Dimensions (Side View) (Mobile Only)



§ § §





# Appendix A Register Bit Index

---

## Symbols

(IOAD) 368

## Numerics

Interrupt Pending Status Port 574

EL\_STATE0\_CNT 486

EL\_STATE1\_CNT 486

Interrupt Pending Status Port 574

I/O Address 368

I/O Limit Address Limit bits 413

Interrupt Pending Status Port 574

GP\_BLINK 521, 522

GP\_IO\_SEL 519

Interrupt Pending Status Port 574

GP\_LVL 520, 526

GPIO\_USE\_SEL 519

GP\_IO\_SEL2 525

Upper Address 675

GP\_LVL 525

GPIO\_USE\_SEL2 524

64 Bit Address Capable 778

64 Bit Address Capable (C64)  
547

64b Address Capability 715

64-bit Address Supported 729

64-bit Addressing Capability 667

64-bit Indicator 764

64-bit Indicator (I64B) 415

64-bit Indicator (I64L) 415

66 MHz Capable 398, 414, 426, 630, 650, 687, 706, 759

66MHz Capable 530, 602

Address 368

## A

A20Gate Pass-Through Enable 636

AC '97 Modem Disable (AMD) 390

AC '97 Static Clock Gate Enable 394

AC97\_EN 501

AC97\_STS 499

ACAZ\_BREAK\_EN 484

Accept Unsolicited Response Enable 731

ACPI Enable 429

Active State Link PM Control 772

Active State Link PM Control (APMC) 364

Active State Link PM Support 771

Active State Link PM Support (APMS) 363

Active-high Byte Enables (AHBE) 367

Address 696, 778

Address (ADDR) 550

Address Enable (AE) 385

Address Increment/Decrement Select 449

Address of Descriptor Table 566, 621

Address Select (AS) 385

Address Translator Enable 781

ADI 456

Advanced Error Interrupt Message Number 791

Advanced Packet Switching 785

Advanced Packet Switching (APS) 355, 356

AECC 791

AFTERG3\_EN 480

Aggressive Link Power Management Enable 589

Aggressive Slumber / Partial 589

AHCI Enable 573

Alarm Flag 472

Alarm Interrupt Enable 471

Alternate A20 Gate 474

Alternate Access Mode Enable (AME) 387

Alternate GPI SMI Enable 506

Alternate GPI SMI Status 506, 507

APIC Data 464

APIC Enable (AEN) 384

APIC ID 465

APIC Index 463

APM\_STS 505

APMC\_EN 503

Arbiter Disable 497

Asynchronous Schedule Enable 669

Asynchronous Schedule Park Capability 667

Asynchronous Schedule Status 671

ASYNCLISTADDR 676

Attention Button Present 717, 768, 774

Attention Button Pressed 776

Attention Button Pressed Enable 775

Attention Indicator Control 775

Attention Indicator Present 717, 768, 774

Auto Flush After Disconnect Enable 419

Autoinitialize Enable 449

Automatic End of Interrupt 458

Automatically Append CRC 699

Aux Current 714

AUX Power Detected 718, 770

Aux Power PM Enable 769





Aux\_Current 403, 780  
 Auxiliary Current 545, 615, 655  
 Auxiliary Power Enable 718  
 Azalia Pin (ZIP) 374  
 Azalia Traffic Class Assignment 711  
 Azalia/AC '97 Signal Mode 711

## B

B2/B3 Support 714, 780  
 Bad DLLP Mask 790  
 Bad DLLP Status 790  
 Bad TLP Mask 790  
 Bad TLP Status 790  
 BAR Location (BARLOC) 559  
 BAR Number 657  
 BAR Offset (BAROFST) 559  
 Base Address 428, 429, 444, 533, 534, 535, 604, 605, 606, 633, 643, 652, 689, 764  
 Base Address (Low) 675  
 Base Address Lower 793  
 Base Address Lower (BAL) 358  
 Base Address Upper 793  
 Base Address Upper (BAU) 358  
 Base and Current Address 446  
 Base and Current Count 446  
 Base Class Code 399, 400, 401, 402, 411, 427, 532, 603, 631, 651, 688, 707, 761  
 BATLOW\_EN 500  
 BATLOW\_STS 498  
 BCC 631, 707, 761  
 BCTRL 766  
 BFCS 561  
 BFTD1 562  
 BFTD2 562  
 Bidirectional Direction Control 746  
 Binary/BCD Countdown Select 452  
 BIOS Interface Lock-Down (BILD) 387  
 BIOS Lock Enable 441  
 BIOS Release 502  
 BIOS Write Enable 441  
 BIOS\_EN 503  
 BIOS\_PCI\_EXP\_EN 477  
 BIOS\_STS 506  
 BIOSWR\_STS 513  
 BIST FIS Failed 561  
 BIST FIS Parameters 562  
 BIST FIS Successful 561  
 BIST FIS Transmit Data 1 562  
 BIST FIS Transmit Data 2 563  
 Bits per Sample 752

Block Data 697  
 Block Delayed Transactions 419  
 Block/Sector Erase Size (BSES) 816  
 BM 484  
 BME Receive Check Enable 782  
 BNUM 762  
 Boot BIOS Straps (BBS) 386  
 BOOT\_STS 514  
 BUC 388  
 Buffer Completion Interrupt Status 748  
 Buffer Descriptor List Pointer Lower Base Address 753  
 Buffer Descriptor List Pointer Upper Base Address 753  
 Buffered Mode 458  
 Bus Master Enable 397, 409, 425, 529, 601, 629, 649, 686, 706, 759  
 Bus Master IDE Active 566, 621  
 Bus Master Reload 493  
 Bus Master Status 491  
 Bus Number (BN) 359, 360, 361, 362, 363  
 Bus Power / Clock Control Enable 780  
 Bus Power/Clock Control Enable 714  
 BUS\_ERR 693  
 Byte Done Status 693  
 Byte Enable Mask (BEM) 368  
 Byte Enables (TBE) 368

## C

C3\_RESIDENCY 510  
 C4 483  
 CAP 571  
 Cap 716  
 Cap ID 713, 715  
 Capabilities List 398, 411, 426, 530, 602, 630, 650, 706, 760  
 Capabilities List Indicator 687  
 Capabilities Pointer 402, 537, 607, 653, 710, 765  
 Capabilities Pointer (PTR) 416  
 Capability 357, 784  
 Capability ID 403, 404, 405, 544, 614, 659, 767, 778, 784, 791  
 Capability ID (CAP) 558  
 Capability ID (CID) 353, 357, 363, 546  
 Capability Identifier 422, 779  
 Capability Register Length Value 665  
 Capability Version 717, 768, 791  
 Capability Version (CV) 353, 363  
 CAPLENGTH 665  
 CAPP 402, 765  
 CAPPTR 710  
 Captured Slot Power Limit Scale 717, 768



Captured Slot Power Limit Value 717, 768  
Cascaded Interrupt Controller IRQ Connection 457  
CC 399  
CCC 577, 578  
CEM 790  
CES 790  
CG 392  
Channel Mask Bits 450  
Channel Mask Select 448  
Channel Request Status 448  
Channel Terminal Count Status 448  
Clear Byte Pointer 449  
Clear Mask Register 450  
CLIST 403, 405, 767  
CLS 399, 708, 761  
CNF1\_LPC\_EN 434  
CNF2\_LPC\_EN 434  
CNTL 681  
Cold Port Detect Status 585  
Cold Presence Detect Enable 587  
COMA Decode Range 433  
COMA\_LPC\_EN 434  
COMB Decode Range 433  
COMB\_LPC\_EN 434  
Command Completed 776  
Command Completed Interrupt Enable 775  
Command List Base Address 584  
Command List Base Address Upper 584, 585  
Command List Override (CLO) 591  
Commands Issued 598  
Common Clock Configuration 772  
Common Clock Exit Latency 782  
Completion 787  
Completion Abort Mask 788  
Completion Abort Severity 789  
Completion Abort Status 787  
Completion Timeout Mask 788  
Completion Timeout Severity 789  
Component ID 792  
Component ID (CID) 357  
CONFIG 683  
CONFIGFLAG 676  
Configuration Layout 632, 761  
Configure Flag 638, 676  
Connect Status Change 646, 680  
Controller Interrupt Enable 736  
Controller Interrupt Status 737  
Controller Reset 731  
Controller Running 590  
Coprocesor Error 475  
Coprocesor Error Enable (CEN) 384  
CORB Lower Base Address 738, 741  
CORB Memory Error Indication 740  
CORB Memory Error Interrupt Enable 740  
CORB Read Pointer (CORBRP) 739  
CORB Read Pointer Reset 739  
CORB Size 740  
CORB Size Capability 740  
CORB Upper Base Address 739  
CORB Write Pointer 739  
CORBCTL 740  
CORBLBASE 738  
CORBRP 739  
CORBSIZE 740  
CORBST 740  
CORBUBASE 739  
CORBWP 739  
Correctable Error Detected 718, 770  
Correctable Error Reporting Enable 718, 769  
Count Register Status 454  
Countdown Type Status 454  
Counter 0 Select 453  
Counter 1 Select 453  
Counter 2 Select 453  
Counter Latch Command 453  
Counter Mode Selection 452  
Counter OUT Pin State 454  
Counter Port 455  
Counter Select 452  
Counter Selection 453  
Counter Size Capability 796  
Counter Value 798  
CPU BIST Enable (CBE) 388  
CPU PLL Lock Time 478  
CPU Power Failure 479  
CPU SLP# Enable 477  
CPU Thermal Trip Status 479  
CRC Error 698  
CTRLDSSEGMENT 675  
Current Command Slot 590  
Current Connect Status 646, 680  
Current Interface Speed 594, 623  
Cx 481  
Cycle Trap SMI# Status (CTSS) 367  
Cyclic Buffer Length 749

**D**  
D1 Support 545, 615, 655, 714  
D1\_Support 403, 780  
D2 Support 545, 615, 655, 714



D2\_Support 403, 780  
 D27IP 374  
 D28IP 373  
 D28IR 379  
 D29IP 372  
 D29IR 377  
 D30IP 371  
 D30IR 377  
 D31IR 375  
 DAT 464  
 Data 556, 560, 714, 779  
 Data (DATA) 567, 622  
 DATA Cycle— RW 803, 805, 806, 807, 811, 815, 816, 827, 829, 830, 831, 832, 833  
 Data Link Layer Active (DLLA) 773  
 Data Link Protocol Error Mask 788  
 Data Link Protocol Error Severity 789  
 Data Link Protocol Error Status 787  
 Data Message Byte 0 698  
 Data Message Byte 1 698  
 Data Mode 471  
 Data Parity Error Detected 411, 414, 426, 530, 602, 630, 687, 706, 763  
 Data Scale 656  
 Data Select 656  
 DATA\_HIGH\_BYTE 702  
 DATA\_LEN\_CNT 682  
 DATA\_LOW\_BYTE 702  
 Data0/Count 696  
 Data1 696  
 DATABUF 683  
 DATABUFFER(63-0) 683  
 Date Alarm 472  
 Daylight Savings Enable 471  
 DCAP 768  
 DCTL 769  
 Debug Port Capability ID 656  
 Debug Port Number 665  
 Debug Port Offset 657  
 Delivery Mode 467  
 Delivery Status 466  
 Descriptor Error 748  
 Descriptor Error Interrupt Enable 746  
 Descriptor Processed 586  
 Descriptor Processed Interrupt Enable 587  
 Destination 466  
 Destination Mode 467  
 Detected Parity Error 398, 410, 414, 426, 530, 602, 630, 650, 687, 706, 759, 763  
 DEV\_ERR 694  
 DEVC 718  
 DEVCAP 717  
 Device / Port Type 768  
 Device Connects 210  
 Device Detection 594, 623  
 Device Detection Initialization 595, 624  
 Device ID 396, 408, 424, 529, 601, 629, 648, 686, 705, 758  
 Device Interlock Enable 587  
 Device Interlock Status 586  
 Device Monitor Status 505  
 Device Number (DN) 359, 360, 361, 362, 363  
 Device Specific Initialization 403, 545, 615, 655, 714, 780  
 Device Status 597  
 Device to Host Register FIS Interrupt Enable 588  
 Device/Port Type 717  
 DEVICE\_ADDRESS 701  
 DEVS 718  
 DEVSEL# Timing Status 398, 414, 426, 530, 602, 630, 650, 687, 706, 759  
 Diagnostics 596, 625  
 DID 396, 705  
 Discard Delayed Transactions 419  
 Discard Timer SERR# Enable 417, 766  
 Discard Timer Status 417, 766  
 Division Chain Select 470  
 DMA 745  
 DMA Channel Group Enable 447  
 DMA Channel Select 448, 449  
 DMA Group Arbitration Priority 447  
 DMA Low Page 447  
 DMA Position Buffer Enable 745  
 DMA Position Lower Base Address 745  
 DMA Position Upper Base Address 745  
 DMA Setup FIS Interrupt 586  
 DMA Setup FIS Interrupt Enable 588  
 DMA Transfer Mode 449  
 DMA Transfer Type 449  
 DMI and PCI Express\* RX Dynamic Clock Gate Enable 393  
 DMI TX Dynamic Clock Gate Enable 393  
 DMISCI\_STS 512  
 DMISERR\_STS 512  
 DMISMI\_STS 512  
 Dock Attach (DA)  
     712  
 Dock Mated (DM) 713, 733  
 Dock Mated Interrupt Status (DMIS) 733  
 Docking Supported (DS) 734



Docking Supported (DS) - R/WO 713  
DONE\_STS 681  
DPLBASE 745  
DPRSLPVR to STPCPU 483  
DPSLP-TO-SLP 483  
DPUBASE 745  
DR 404  
DRAM Initialization Bit 478  
Drive 0 DMA Capable 566, 586, 621  
Drive 0 DMA Timing Enable 539, 609  
Drive 0 Fast Timing Bank 539, 609  
Drive 0 IORDY Sample Point Enable 539, 609  
Drive 0 Prefetch/Posting Enable 539, 609  
Drive 1 DMA Capable 566, 621  
Drive 1 DMA Timing Enable 538, 608  
Drive 1 Fast Timing Bank 539, 609  
Drive 1 IORDY Sample Point Enable 538, 608  
Drive 1 Prefetch/Posting Enable 538, 608  
Drive 1 Timing Register Enable 538, 608  
Drive LED on ATAPI Enable 589  
DSTS 770

## E

ECAP 734  
ECRC 791  
ECRC Check Capable 791  
ECRC Check Enable 791  
ECRC Error Mask 788  
ECRC Error Severity 789  
ECRC Error Status 787  
ECRC Generation Enable 791  
Edge/Level Bank Select (LTIM) 456  
EHC Initialization 204  
EHC Resets 205  
EHCI Disable (EHCID) 390  
EHCI Extended Capabilities Pointer 667  
EHCI Pin (EIP) 372  
EHCI\_BREAK\_EN 484  
EL\_EN—R/W  
487  
EL\_LED\_OWN—R/W  
486  
EL\_PB\_SCI\_STS - R/WC 485  
EL\_PB\_SMI\_STS - R/WC  
485  
EL\_SCI\_EN — R/W 500  
EL\_SCI\_NOW\_STS- R/WC  
485  
EL\_SCI\_STS — R/WC 498  
EL\_SMI\_EN — R/W 502

EL\_SMI\_STS — RO 504  
Element Type 792  
Element Type (ET) 357  
EM 579, 580  
Enable 444  
Enable 32-Byte Buffer 699  
Enable CORB DMA Engine 740  
Enable No Snoop 769  
Enable Relaxed Ordering 718, 769  
Enable RIRB DMA Engine 742  
Enable Special Mask Mode 460  
ENABLED\_CNT 681  
End of SMI 503  
Endpoint L0 Acceptable Latency 768  
Endpoint L0s Acceptable Latency 717  
Endpoint L1 Acceptable Latency 717, 768  
Enter C4 When C3 Invoked 477  
Enter Global Suspend Mode 638  
EOIR 464  
Erase Opcode 816  
ERBA 402  
ERR\_COR Received 791  
ERR\_FATAL/NONFATAL Received 791  
Error 566, 592, 597, 621, 625  
ERROR\_GOOD#\_STS 681  
ESD 357, 723, 792  
EXCEPTION\_STS 681  
Extended Destination ID 466  
Extended Synch 772  
Extended Synch (ES) 364  
Extended Tag Field Enable 718, 769  
Extended Tag Field Support 717  
Extended Tag Field Supported 768  
Extended VC Count (EVC) 353

## F

FADDR 804, 829  
FAILED 693  
Fast Back to Back Capable 398, 411, 414, 426, 530,  
602, 630, 650, 687, 706, 759  
Fast Back to Back Enable 397, 409, 417, 425, 529, 601,  
629, 686, 705, 758, 766  
Fast Primary Drive 0 Base Clock 543, 613  
Fast Primary Drive 1 Base Clock 543, 613  
Fast Secondary Drive 0 Base Clock 543, 613  
Fast Secondary Drive 1 Base Clock 543, 613  
Fatal Error Detected 718, 770  
Fatal Error Reporting Enable 718, 769  
FB\_40\_EN 440  
FB\_40\_IDSEL 438



FB\_50\_EN 440  
 FB\_50\_IDSEL 438  
 FB\_60\_EN 440  
 FB\_60\_IDSEL 438  
 FB\_70\_EN 440  
 FB\_70\_IDSEL 438  
 FB\_C0\_EN 439, 440  
 FB\_C0\_IDSEL 437  
 FB\_C8\_EN 439  
 FB\_C8\_IDSEL 437  
 FB\_D0\_EN 439  
 FB\_D0\_IDSEL 437  
 FB\_D8\_EN 439  
 FB\_D8\_IDSEL 437  
 FB\_E0\_EN 439  
 FB\_E0\_IDSEL 437  
 FB\_E8\_EN 439  
 FB\_E8\_IDSEL 437  
 FB\_F0\_EN 439  
 FB\_F0\_IDSEL 437  
 FB\_F8\_EN 439  
 FB\_F8\_IDSEL 437  
 FDATA0 805, 829  
 FDATAN 805  
 FDD Decode Range 432  
 FDD\_LPC\_EN 434  
 FDOC 814  
 FDOD 815  
 FERR# MUX Enable (FME) 386  
 FIFO Error 748  
 FIFO Error Interrupt Enable 746  
 FIFO Ready 748  
 FIFO Size 751  
 FIFO Watermark 750  
 First Error Pointer 791  
 FIS Base Address 585  
 FIS Receive Enable 590  
 FIS Receive Running 590  
 FLCOMP 818  
 FLILL 820  
 Flow Control Protocol Error Mask 788  
 Flow Control Protocol Error Severity 789  
 Flow Control Protocol Error Status 787  
 FLREG0 821  
 Flush Control 731  
 Flush Status 733, 814, 835  
 FLVALSIG 817  
 Force Global Resume 638  
 Force Port Resume 679  
 Force Thermal Throttling 494  
 Frame Length Timing Value 658  
 Frame List Current Index/Frame Number 642, 674  
 Frame List Rollover 672  
 Frame List Rollover Enable 673  
 Frame List Size 670  
 FRAP 806, 829  
 FREG0 806, 830  
 FREG1 807, 830  
 FREG2 807, 831  
 FREG3 807, 831  
 FRINDEX 674  
 Full Reset 475  
 Function Number (FN) 359, 360, 361, 362, 363

**G**

GAMEH\_LPC\_EN 434  
 GAMEL\_LPC\_EN 434  
 GBL\_SMI\_EN 503  
 GC 430  
 GCAP 729, 796  
 GCS 386  
 GCTL 731  
 GEN 797  
 Generic Decode Range 1 Enable 435, 436  
 Generic I/O Decode Range 1 Base Address 435, 436  
 GHC 572  
 GINTR 797  
 Global Enable 492  
 Global Interrupt Enable 736  
 Global Interrupt Status 737  
 Global Release 493  
 Global Reset 639  
 Global Status 491  
 GO\_CNT 681  
 GP 525  
 GP\_INV(n) 523  
 GPE0\_STS 505  
 GPIIn\_EN 500  
 GPIIn\_STS 497  
 GPIO 523  
 GPIO Enable 430  
 GPIO0 Route 487  
 GPIO1 Route 487  
 GPIO11\_ALERT\_DISABLE 516  
 GPIO15 Route 487  
 GPIO2 Route 487  
 GPIOBASE 429  
 GSTS 733

**H**

HBA Reset 573  
HC BIOS Owned Semaphore 659  
HC OS Owned Semaphore 659  
HCCPARAMS 667  
HCHalted 641, 671  
HCIVERSION 665  
HCSPARAMS 665  
HDBA 361  
HDBARL 708  
HDBARU 709  
HDCTL 711  
HDD 361  
HDevice is ATAPI 589  
Header Type 412, 428, 708  
HEADTYP 428, 708  
Hide Device 0 418  
Hide Device 1 418  
Hide Device 2 418  
Hide Device 3 418  
High Definition Audio Dynamic Clock Gate Enable 392  
High Definition Audio Static Clock Gate Enable 392, 394  
High Priority Port (HPP) 365  
High Priority Port Enable (HPE) 365  
Host Bus Data Error Enable 587  
Host Bus Data Error Status 586  
Host Bus Fatal Error Enable 587  
Host Bus Fatal Error Status 585  
Host Controller Process Error 641  
Host Controller Reset 639, 670  
Host System Error 641, 671  
Host System Error Enable 673  
HOST\_BUSY 694  
HOST\_NOTIFY\_INTREN 701  
HOST\_NOTIFY\_STS 700  
HOST\_NOTIFY\_WKEN 701  
Hot Plug Attention Button SMI Status 783  
Hot Plug Capable 774  
Hot Plug Capable Port 590  
Hot Plug Command Completed SMI Status 783  
Hot Plug Interrupt Enable 775  
Hot Plug Link Active State Changed SMI Status (HPLAS) 783  
Hot Plug Presence Detect SMI Status 783  
Hot Plug SCI Enable 781  
Hot Plug SCI Status 783  
Hot Plug SMI Enable 782  
Hot Plug Surprise 774

HOT\_PLUG\_EN 501  
HOT\_PLUG\_STS 499  
Hour Format 471  
HPTC 385  
HSFC 804, 828  
HSFS 803, 827  
HT 400

**I**

I/O Base Address 762  
I/O Base Address (IOBA) 413  
I/O Base Address Capability 413, 762  
I/O Limit Address 762  
I/O Limit Address Capability 762  
I/O Space Enable 397, 409, 425, 529, 601, 629, 649, 686, 706, 759  
I2C 220  
I2C\_EN 691  
i64\_EN 477  
IC 743  
ICW/OCW Select 456  
ICW4 Write Required 456  
ID 465  
IDE 484  
IDE Decode Enable 538, 608  
IDE\_ACT\_STS 509  
I/O Limit Address Capability 413  
ILCL 363  
Immediate Command Busy 744  
Immediate Command Write 743  
Immediate Response Read 744  
Immediate Result Valid 744  
IN\_USE\_CNT 681  
Incorrect Port Multiplier Enable 587  
Incorrect Port Multiplier Status 586  
IND 463  
Index (INDEX) 567, 622  
INIT\_NOW 474  
INPAY 730  
Input FIFO Padding Type (IPADTYPE) 735  
Input Payload Capability 730  
Input Stream Payload Capability (INSTRMPAY) 735  
INSTRMPAY 735  
INTCTL 736  
Intel 374, 390  
Intel PRO/Wireless 3945ABG Status 784  
Intel SpeedStep Enable 477  
INTEL\_USB2\_EN 502  
INTEL\_USB2\_STS 504  
Interface 531, 532, 603



Interface Communication Control 589  
 Interface Fatal Error Status 586  
 Interface Non-fatal Error Enable 587  
 Interface Non-fatal Error Status 586  
 Interface Power Management 594, 623  
 Interface Power Management Transitions Allowed 595, 624  
 Interface Speed Support 571  
 Interlock Switch Attached to Port 590  
 Interlock Switch State 590  
 Interrupt 566, 621  
 Interrupt A Pin Route (IAR) 376, 378, 380, 381, 382, 383  
 Interrupt B Pin Route (IBR) 376, 377, 379, 381, 382, 383  
 Interrupt C Pin Route (ICR) 376, 377, 379, 380, 382, 383  
 Interrupt D Pin Route (IDR) 375, 376, 377, 379, 380  
 Interrupt Disable 397, 409, 529, 601, 629, 649, 686, 705, 758  
 Interrupt Enable 573  
 Interrupt Input Pin Polarity 466  
 Interrupt Level Select 459  
 Interrupt Line 402, 416, 537, 607, 634, 653, 690, 710, 766  
 Interrupt Message Number 717, 768  
 Interrupt on Async Advance 671  
 Interrupt on Async Advance Doorbell 669  
 Interrupt on Async Advance Enable 673  
 Interrupt on Complete Enable 642  
 Interrupt on Completion Enable 746  
 Interrupt PIN 690  
 Interrupt Pin 402, 416, 537, 607, 653, 710, 766  
 Interrupt Request Flag 472  
 Interrupt Request Level 457  
 Interrupt Request Mask 459  
 Interrupt Rout 798  
 Interrupt Routing Enable 430, 432  
 Interrupt Status 398, 411, 426, 530, 602, 630, 650, 687, 706, 760  
 Interrupt Threshold Control 669  
 Interrupt Vector Base Address 457  
 INTLN 710  
 INTPN 710  
 INTR 402, 694, 766  
 INTRD\_SEL 516  
 INTREN 695  
 Intruder Detect 514  
 INTSTS 737  
 INUSE\_STS 693  
 Invalid Receive Range Check Enable 782  
 IO Space Indicator 689  
 IOBL 762  
 IOCHK# NMI Enable 473  
 IOCHK# NMI Source Status 473  
 IORDY Sample Point 538, 608  
 IR 744  
 IReserved 375  
 IRQ Routing 430, 432  
 IRQ1\_CAUSE 517  
 IRQ10 ECL 462  
 IRQ11 ECL 462  
 IRQ12 ECL 462  
 IRQ12\_CAUSE 517  
 IRQ14 ECL 462  
 IRQ15 ECL 462  
 IRQ3 ECL 461  
 IRQ4 ECL 461  
 IRQ5 ECL 461  
 IRQ6 ECL 461  
 IRQ7 ECL 461  
 IRQ9 ECL 462  
 IRS 744  
 IS 574  
 ISA Enable 418, 767  
 Isochronous Scheduling Threshold 667

**K**

KBC\_ACT\_STS 509  
 KBC\_LPC\_EN 434  
 KILL 695

**L**

L0s Exit Latency 771  
 L0s Exit Latency (EL0) 363  
 L1 Exit Latency 771  
 L1 Exit Latency (EL1) 363  
 L1ADDL 724  
 L1ADDU 724  
 L1DESC 724  
 Last Valid Index 750  
 LAST\_BYTE 694  
 Latch Count of Selected Counters 453  
 Latch Status of Selected Counters 453  
 Latency Count 761  
 Latency Timer 708  
 LCAP 363, 770  
 LCTL 364, 772  
 Legacy (LPC) Dynamic Clock Gate Enable 392  
 Legacy Replacement Rout 797



Legacy Replacement Rout Capable 796  
LEGACY\_USB\_EN 503  
LEGACY\_USB\_STS 506  
LEGACY\_USB2\_EN 502  
LEGACY\_USB2\_STS 504  
Light Host Controller Reset 669  
Line Status 646, 678  
Link 360, 362  
Link Active Changed Enable (LACE) 775  
Link Active Reporting Capable (LARC) 770  
Link Active State Changed (LASC) 776  
Link Disable 772  
Link Hold Off 781  
Link Pointer Low 676  
Link Position in Buffer 749  
Link Speed 773  
Link Speed (LS) 364  
Link Training 773  
Link Training Error 773  
Link Type 792  
Link Type (LT) 358, 359, 360, 361  
Link Valid 792  
Link Valid (LV) 358, 359, 360, 361, 362  
LINK\_ID\_STS 681  
Load Port Arbitration Table 786  
Load Port Arbitration Table (LAT) 355, 356  
Load VC Arbitration Table 785  
Load VC Arbitration Table (LAT) 354  
Loop Back Test Mode 638  
Low Priority Extended VC Count (LPEVC) 353  
Low Speed Device Attached 646  
Lower 128 Byte Lock (LL) 385  
Lower Base Address 708  
LPC 371, 432  
LPC Bridge Disable (LBD) 390  
LPT Decode Range 432  
LPT\_LPC\_EN 434  
LSTS 364, 773  
LT 708

**M**  
MA 778  
MADDH 406  
MADDL 405  
MAIN 798  
Main Counter Tick Period 796  
Major Revision (MAJREV) 558  
Major Version 729  
Major Version Number 576  
Malformed TLP Mask 788  
Malformed TLP Severity 789  
Malformed TLP Status 787  
Map Value 551, 617  
Mask 466  
Mask (ADMA) 368  
Master Abort Mode 417, 766  
Master Abort Status 426  
Master Clear 450  
Master Data Parity Error Detected 398, 650, 759  
Master Latency Count 427  
Master Latency Timer 632  
Master Latency Timer Count 412, 413, 533, 604, 652  
Master/Slave in Buffered Mode 458  
Max Packet 638  
Max Payload Size 718, 769  
Max Payload Size Supported 717, 768  
Max Read Request Size 718, 769  
Maximum Delayed Transactions 419  
Maximum Link Speed 771  
Maximum Link Speed (MLS) 363  
Maximum Link Width 771  
Maximum Link Width (MLW) 363  
Maximum Redirection Entries 465  
Maximum Time Slots 785  
Maximum Time Slots (MTS) 354, 356  
MBARA 400  
MBARB 400  
MBARC 401  
MBL 764  
MC 778  
MC\_LPC\_EN 434  
MCSMI\_EN Microcontroller SMI Enable 502  
MCTL 405  
MD 779  
MDAT 406  
Memory Base 415, 764  
Memory Limit 415, 764  
Memory Read Line Prefetch Disable 419  
Memory Read Multiple Prefetch Disable 419  
Memory Read Prefetch Disable 419  
Memory Space Enable 397, 409, 425, 529, 601, 629, 649, 686, 706, 759  
Memory Write and Invalidate Enable 409, 706  
Message Data 716  
Message Lower Address 716  
Message Upper Address 716  
Microcontroller SMI# Status 505  
Microprocessor Mode 458  
MID 715, 778  
Minimum SLP\_S4# Assertion Width Violation Status





- 479  
 Minor Revision (MINREV) 558  
 Minor Version 729, 803, 804, 805, 806, 807, 808, 809, 810, 811, 812, 815, 827, 828, 829, 830, 831, 832, 833, 834  
 Minor Version Number 576  
 MLMG 402  
 MMC 715  
 MMD 716  
 MMLA 716  
 MMUA 716  
 Mobile IDE Configuration Lock Down (MICLD) 386  
 Mode Selection Status 454  
 MONITOR\_STS 504  
 MPC 781  
 MRL Sensor Changed 776  
 MRL Sensor Changed Enable 775  
 MRL Sensor Present 774  
 MRL Sensor State 776  
 MSI Enable 715, 778  
 MSI Enable (MSIE) 549  
 Multi-Function Device 412, 428, 632, 761  
 Multiple ERR\_COR Received 791  
 Multiple ERR\_FATAL/NONFATAL Received 791  
 Multiple Message Capable 715, 778  
 Multiple Message Capable (MMC) 548  
 Multiple Message Enable 715, 778  
 Multiple Message Enable (MME) 548
- N**
- N Response Interrupt Count 742  
 N\_PORTS 666  
 Negotiated Link Width 773  
 Negotiated Link Width (NLW) 364  
 Never Prefetch 419  
 NEWCENTURY\_STS 513  
 Next Capability 403, 405, 406, 422, 544, 614, 713, 715, 716, 767, 779, 791  
 Next Capability (NEXT) 357  
 Next Capability Offset 784  
 Next Capability Offset (NCO) 353  
 Next Capability Offset (NEXT) 363  
 Next Capability Pointer (NEXT) 558  
 Next EHCI Capability Pointer 659  
 Next Item Pointer 1 Value 654  
 Next Item Pointer 2 Capability 657  
 Next Pointer 778  
 Next Pointer (NEXT) 546  
 NMI Enable 474  
 NMI\_NOW 515
- NMI2SMI\_EN 515  
 NMI2SMI\_STS 513  
 No Reboot (NR) 386  
 No Snoop Enable 718  
 Non-Fatal Error Detected 718, 770  
 Non-Fatal Error Reporting Enable 718, 769  
 NOTIFY 701, 702  
 Number of Active Transactions 420  
 Number of Bidirectional Stream Supported 729  
 Number of Channels 752  
 Number of Companion Controllers 665  
 Number of Input Stream Supported 729  
 Number of Link Entries 792  
 Number of Link Entries (NLE) 357  
 Number of Output Stream Supported 729  
 Number of Pending Transactions 420  
 Number of Ports 572  
 Number of Ports per Companion Controller 666  
 Number of Serial Data Out Signals 729  
 Number of Timer Capability 796  
 nvalid Receive Bus Number Check Enable 781
- O**
- OCW2 Select 459  
 OCW3 Select 460  
 OIC 384  
 OPMENU 814, 835  
 OPTYPE 813, 834  
 OS\_POLICY 516  
 OUTPAY 730  
 Output FIFO Padding Type (OPADTYPE) 734  
 Output Payload Capability 730  
 Output Stream Payload Capability (OUTSTRMPAY) 734  
 OUTSTRMPAY 734  
 Overall Enable 797  
 Overcurrent Active 646, 679  
 Overcurrent Change 679  
 Overcurrent Indicator 645  
 Overflow Error Enable 587  
 Overflow Status 586  
 OWNER\_CNT 681
- P**
- Parallel 391  
 Parity Error Response 397, 409, 425, 529, 601, 629, 649, 686, 706, 758  
 Parity Error Response Enable 418, 767  
 Partial State Capable 572  
 Pass Through State 636



PATA Dynamic Clock Gate Enable 392  
PATA Pin (SMIP) 370  
PATA Reset State (PRS) 388  
PC 714  
PCI Bridge Pin (PIP) 370  
PCI CLKRUN# Enable 478  
PCI Dynamic Gate Enable 393  
PCI Express #1 Pin (P1IP) 374  
PCI Express #2 Pin (P2IP) 373  
PCI Express #3 Pin (P3IP) 373  
PCI Express #4 Pin (P4IP) 373  
PCI Express 1 Disable (PE1D) 389  
PCI Express 2 Disable (PE2D) 389  
PCI Express 3 Disable (PE3D) 389  
PCI Express 4 Disable (PE4D) 389  
PCI Express Root Port Static Clock Gate Enable 393  
PCI Express TX Dynamic Clock Gate Enable 393  
PCI Express Wake Disable 492  
PCI Express Wake Status 490  
PCI Interrupt Enable 635  
PCI SERR# Enable 473  
PCI\_BREAK\_EN 484  
PCI\_EXP\_EN 500  
PCI\_EXP\_SMI\_STS 504  
PCI\_EXP\_STS 498  
PCICMD 397, 705  
PCIE\_BREAK\_EN 484  
PCISTS 398, 706  
PCS 714  
PEC\_DATA 697  
PEC\_EN 694  
Peer Decode Enable 421  
PEETM 793  
Periodic Interrupt Capable 799  
Periodic Interrupt Enable 471  
Periodic Interrupt Flag 472  
Periodic Schedule Enable 670  
Periodic Schedule Status 671  
Periodic SMI# Rate Select 478  
PERIODIC\_EN 502  
PERIODIC\_STS 505  
PERIODICLISTBASE 675  
PERR# Assertion Detected 420  
PERR#-to-SERR# Enable 421  
Phantom 769  
Phantom Function Enable 718  
Phantom Functions Supported 717, 768  
PhyRdy 587  
PhyRdy Change Status 586  
Physical Slot Number 774  
PI 575, 688, 707  
PID 713  
PIO Multiple DRQ Block (PMD) 572  
PIO Setup FIS Interrupt 586  
PIO Setup FIS Interrupt Enable 588  
PIRQAE\_ACT\_STS 509  
PIRQBF\_ACT\_STS 509  
PIRQCG\_ACT\_STS 509  
PIRQDH\_ACT\_STS 509  
PLT 399, 427  
PM1\_STS\_REG 505  
PMBL 764  
PMBU32 765  
PMC 403, 780  
PMCAP 779  
PMCS 404, 780  
PME Clock 403, 545, 615, 655, 714, 780  
PME Enable 404, 546, 616, 656, 714, 781  
PME Interrupt Enable 777  
PME Pending 777  
PME Requestor ID 777  
PME Status 404, 546, 616, 656, 714, 777, 780  
PME Support 545, 615, 655, 714  
PME\_B0\_EN 500  
PME\_B0\_STS 498  
PME\_EN 500  
PME\_STS 498  
PME\_Support 403, 780  
PMLU32 765  
Poisoned TLP Mask 788  
Poisoned TLP Severity 789  
Poisoned TLP Status 787  
Poll Mode Command 460  
Popdown Mode Enable 481, 482  
Popup Mode Enable 482  
Port 557, 558  
Port 0 BIST FIS Initiate 562  
Port 0 Enabled 553, 617  
Port 0 Present 552, 617  
Port 1 BIST FIS Initiate 562  
Port 1 Enabled 553, 617  
Port 1 Present 552, 617  
Port 2 BIST FIS Initiate 561  
Port 2 Enabled 553  
Port 2 Present 552  
Port 3 BIST FIS Initiate 561  
Port 3 Enabled 552, 553  
Port 3 Present 552  
Port Arbitration Capability 785  
Port Arbitration Capability (PAC) 355, 356



Port Arbitration Select 786  
 Port Arbitration Select (PAS) 355, 356  
 Port Arbitration Table Entry Size (PATS) 353  
 Port Arbitration Table Offset 785  
 Port Arbitration Table Offset (AT) 354, 356  
 Port Arbitration Tables Status 786  
 Port Arbitration Tables Status (ATS) 355, 357  
 Port Change Detect 672  
 Port Change Interrupt Enable 587, 673  
 Port Configuration (PC) 365  
 Port Connect Change Status 586  
 Port Enable/Disable Change 646, 679  
 Port Enabled/Disabled 646, 680  
 Port I/OxApic Enable 782  
 Port Multiplier FIS Based Switching Enable 590  
 Port Multiplier Attached 590  
 Port Multiplier Port 595, 624  
 Port Number 770, 792  
 Port Number (PN) 357  
 Port Owner 678  
 Port Power 678  
 Port Reset 646, 678  
 Port Test Control 678  
 Port Wake Implemented 659  
 Port Wake Up Capability Mask 659  
 PORT0EN 636  
 PORT1EN 636  
 Ports Implemented Port 0 575, 577, 580  
 Ports Implemented Port 1 575  
 Ports Implemented Port 2 575  
 Ports Implemented Port 3 575, 577, 578, 579, 580  
 PORTSC 677  
 Postable Memory Write Enable 397, 425, 529, 601, 629, 649, 686, 758  
 Power Button Enable 492  
 Power Button Override Status 490  
 Power Button Status 491  
 Power Controller Control 775  
 Power Controller Present 774  
 Power Failure 480  
 Power Fault Detected 776  
 Power Fault Detected Enable 775  
 Power Indicator Control 775  
 Power Indicator Present 717, 768, 774  
 Power Management Capability ID 654  
 Power Management SCI Enable 781  
 Power Management SCI Status 783  
 Power Management SMI Enable 782  
 Power Management SMI Status 783  
 Power On Device 591  
 Power Sequencing 285  
 Power State 404, 546, 616, 656, 715, 781  
 PR0 808, 831  
 PR1 808, 832  
 PR2 809  
 PR3 809  
 PR4 810  
 PRD Interrupt Status 566, 621  
 Prefetchable 535, 652, 708, 764  
 Prefetchable Memory Base 415, 764  
 Prefetchable Memory Base Upper Portion 416, 765  
 Prefetchable Memory Limit 415  
 Prefetchable Memory Limit Upper Portion 416, 765  
 Prefix 813, 834  
 Prefix Opcode 0 813, 834  
 Prefix Opcode 1 813, 834  
 PREOP 813, 834  
 Presence Detect Changed 776  
 Presence Detect Changed Enable 775  
 Presence Detect State 776  
 PRIM\_SIG\_MODE 543, 613  
 Primary Bus Number 412, 762  
 Primary Discard Timer 417, 766  
 Primary Drive 0 Base Clock 544, 614  
 Primary Drive 0 Cycle Time 542, 612  
 Primary Drive 0 Synchronous DMA Mode Enable 541, 611  
 Primary Drive 1 Base Clock 544, 614  
 Primary Drive 1 Cycle Time 542  
 Primary Drive 1 IORDY Sample Point 540  
 Primary Drive 1 Recovery Time 540  
 Primary Drive 1 Synchronous DMA Mode Enable 541  
 Primary Master Trap 560  
 Primary Mode Native Capable 531, 603  
 Primary Mode Native Enable 531, 603  
 Primary Slave Trap 560  
 Programmable Frame List Flag 667  
 Programming Interface 399, 411, 427, 631, 651, 707, 760  
 PRQ 465  
 PVC 354, 785  
 PVCCAP1 719  
 PVCCAP2 720  
 PVCCTL 720  
 PVCSTS 720  
 PVS 354, 785  
 PWRBTN\_EVNT—WO  
     486  
 PWRBTN\_INT\_EN—R/W  
     486



PWRBTN\_LVL 477  
PWROK Failure 479  
PXC 717  
PxCI 597  
PxCLB 583  
PxCLBU 584  
PxCMD 589  
PxFB 585  
PxFBU 585  
PXID 716  
PxIE 587  
PxIS 585  
PxSACT 597  
PxSCTL 595, 624  
PxSERR 596, 625  
PxSIG 593  
PxSSTS 594, 623  
PxTFD 591

## R

Rate Select 470  
RC 385  
RCBA 444  
RCCAP 723  
RCTCL 357, 791  
RCTL 777  
Read / Write Control 565, 620  
Read Back Command 453  
Read Completion Boundary Control 772  
Read/Write Mask (RWM) 368  
Read/Write Select 452  
Read/Write Selection Status 454  
Read/Write# (RWI) 367  
Read/Write# (RWIO) 368  
Real Time Clock Index Address 474  
Received 763  
Received Master Abort 398, 411, 414, 530, 602, 630, 650, 687, 706, 759  
Received System Error 414, 763  
Received Target Abort 398, 411, 414, 426, 650, 687, 706, 759, 763  
Received Target Abort SERR# Enable 421  
RECEIVED\_PID\_STS(23-16) 682  
Receiver Error Mask 790  
Receiver Error Status 790  
Receiver Overflow Mask 788  
Receiver Overflow Severity 789  
Receiver Overflow Status 787  
Reclamation 671  
Recovery Time 538, 608  
REDIR 466  
Redirection Entry Clear 464  
Reference Clock (RC) 353  
Refresh Cycle Toggle 473  
Register Read Command 460  
Reject Snoop Transactions 785  
Reject Snoop Transactions (RTS) 355, 356  
Remote IRR 466  
Replay Number Rollover Mask 790  
Replay Number Rollover Status 790  
Replay Timer Timeout Mask 790  
Replay Timer Timeout Status 790  
Report Zero for BM\_STS 482  
RES 791  
Reserved Page Route (RPR) 387  
Reset CPU 475  
Resource Type Indicator 428, 533, 534, 535, 604, 605, 606, 633, 652  
Response Interrupt 743  
Response Interrupt Control 742  
Response Overrun Interrupt Control 742  
Response Overrun Interrupt Status 743  
Resume Detect 641, 646  
Resume Interrupt Enable 642  
Retrain Link 772  
Revision ID 399, 411, 427, 530, 602, 630, 651, 687, 707, 760  
Revision Identificaiton 796  
RI\_EN 500  
RI\_STS 498  
RID 399, 687  
RINTCNT 742  
RIRB Lower Base Unimplemented Bits 741  
RIRB Size 743  
RIRB Size Capability 743  
RIRB Upper Base Address 741  
RIRB Write Pointer 741  
RIRB Write Pointer Reset 741  
RIRBCTL 742  
RIRBLBASE 741  
RIRBSIZE 743  
RIRBSTS 743  
RIRBUBASE 741  
RIRBWP 741  
Rotate and EOI Codes 459  
RP1BA 359  
RP1D 358  
RP2BA 359  
RP2D 359  
RP3BA 360



RP3D 360  
 RP4BA 361  
 RP4D 360  
 RP5BA 362  
 RP5D 362  
 RP6BA 363  
 RP6D 362  
 RPFN—Root Port Function Number for PCI Express  
 Root Ports 366  
 RSTS 777  
 RTC 470, 471, 472  
 RTC Event Enable 492  
 RTC Status 491  
 RTC\_PWR\_STSRTC Power Status 480  
 Run/Stop 639, 670  
 RW 696

## S

Sample Base Rate 752  
 Sample Base Rate Divisor 752  
 Sample Base Rate Multiple 752  
 SATA 557  
 SATA 3 Gb/s Capability 443  
 SATA Pin (SIP) 370  
 SATA Port 0 Dynamic Clock Gate Enable 392  
 SATA Port 1 Dynamic Clock Gate Enable 392  
 SATA Port 2 Dynamic Clock Gate Enable 392  
 SATA Port 3 Dynamic Clock Gate Enable 392  
 SCI Enable 493  
 SCI IRQ Select 429  
 SCI\_NOW\_CNT—WO 486  
 SCLKCG 554  
 SCLKGC 555  
 Scrambler Bypass Mode 793  
 SCRATCHPAD 482  
 Scratchpad 642  
 Scratchpad Bit 465  
 SDBDPL 753  
 SDBDPU 753  
 SDCBL 749  
 SDCTL 746  
 SDFIFOS 751  
 SDFIFOW 750  
 SDFMT 752  
 SDIN State Change Status Flags 733, 813, 834, 835  
 SDIN Wake Enable Flags 732  
 SDLPIB 749  
 SDLVI 750  
 SDSTS 748  
 SEC\_SIG\_MODE 543, 613  
 SECOND\_TO\_STS 514  
 Secondary 560  
 Secondary 66 MHz Capable 763  
 Secondary Bus Number 412, 762  
 Secondary Bus Reset 417, 766  
 Secondary DEVSEL# Timing Status 763  
 Secondary Discard Timer 417, 766  
 Secondary Discard Timer Testmode 421  
 Secondary Drive 0 Base Clock 544, 614  
 Secondary Drive 0 Cycle Time 542, 612  
 Secondary Drive 0 Synchronous DMA Mode Enable 541, 611  
 Secondary Drive 1 Base Clock 544, 614  
 Secondary Drive 1 Cycle Time 542  
 Secondary Drive 1 IORDY Sample Point 540  
 Secondary Drive 1 Recovery Time 540  
 Secondary Drive 1 Synchronous DMA Mode Enable 541  
 Secondary Fast Back to Back Capable 763  
 Secondary Master Trap 560  
 Secondary Mode Native Capable 531, 603  
 Secondary Mode Native Enable 531, 603  
 Secondary Slave Trap 555, 560  
 Select Power Management 595, 624  
 SEND\_PID\_CNT(15-8) 682  
 Serial ATA Disable (SAD) 390  
 Serial Bus Release Number 634  
 Serial IRQ Enable 431  
 Serial IRQ Frame Size 431  
 Serial IRQ Mode Select 431  
 SERIRQ\_SMI\_STS 505  
 SERR# Enable 397, 409, 418, 425, 529, 601, 629, 649, 686, 705, 758, 767  
 SERR# NMI Source Status 473  
 SERR# Status 706  
 Server Error Reporting Mode (SERM) 386  
 Set Device Bits FIS Interrupt Enable 587  
 Set Device Bits Interrupt 586  
 Short Packet Interrupt Enable 642  
 SID 401, 690, 709  
 Signaled System Error 398, 410, 426, 530, 602, 650, 687, 759  
 Signaled Target Abort 398, 411, 414, 426, 530, 602, 630, 650, 687, 706, 759, 763  
 Signature 593  
 Single or Cascade 456  
 Slave Identification Code 458  
 SLAVE\_ADDR 698



SLCAP 774  
SLCTL 775  
Sleep Enable 493  
Sleep Type 493  
Slot Clock Configuration 773  
Slot Implemented 717, 768  
Slot Power Limit Scale 774  
Slot Power Limit Value 774  
SLP\_S4# Assertion Stretch Enable 480  
SLP\_S4# Minimum Assertion Width 480  
SLP\_SMI\_EN 503  
SLP\_SMI\_STS 505  
SLSTS 776  
SLT 762  
Slumber State Capable 572  
SLV 700, 701  
SM Bus Disable (SD) 390  
SM Bus Pin (SMIP) 370  
SMB\_CMD 695  
SMB\_SMI\_EN 691  
SMBALERT\_DIS 701  
SMBALERT\_STS 693  
SMBCLK\_CTL 700  
SMBCLK\_CUR\_STS 700  
SMBDATA\_CUR\_STS 700  
SMBUS 700  
SMBus Host Enable 691  
SMBus SMI Status 504  
SMBus TCO Mode 698  
SMBus Wake Status 499  
SMI at End of Pass-Through Enable 636  
SMI Caused by End of Pass-Through 635  
SMI Caused by Port 60 Read 635  
SMI Caused by Port 60 Write 635  
SMI Caused by Port 64 Read 635  
SMI Caused by Port 64 Write 635  
SMI Caused by USB Interrupt 635  
SMI on Async 662  
SMI on Async Advance 660  
SMI on Async Advance Enable 661  
SMI on Async Enable 662  
SMI on BAR 660  
SMI on BAR Enable 660  
SMI on CF 662  
SMI on CF Enable 663  
SMI on Frame List Rollover 660  
SMI on Frame List Rollover Enable 661  
SMI on HCHalted 662  
SMI on HCHalted Enable 663  
SMI on HCRReset 662  
SMI on HCRReset Enable 663  
SMI on Host System Error 660  
SMI on Host System Error Enable 661  
SMI on OS Ownership Change 660  
SMI on OS Ownership Enable 661  
SMI on PCI Command 660  
SMI on PCI Command Enable 660  
SMI on Periodic 662  
SMI on Periodic Enable 663  
SMI on PMCSR 662  
SMI on PMSCR Enable 662  
SMI on Port 60 Reads Enable 636  
SMI on Port 60 Writes Enable 636  
SMI on Port 64 Reads Enable 636  
SMI on Port 64 Writes Enable 636  
SMI on Port Change Detect 660  
SMI on Port Change Enable 661  
SMI on PortOwner 662  
SMI on PortOwner Enable 662  
SMI on USB Complete 660  
SMI on USB Complete Enable 661  
SMI on USB Error 660  
SMI on USB Error Enable 661  
SMI on USB IRQ Enable 636  
SMI\_LOCK 477  
SMI\_OPTION\_CNT—R/W  
486  
SMLINK 699  
SMLink Slave SMI Status 514  
SMLINK\_CLK\_CTL 699  
SMLINK0\_CUR\_STS 699  
SMLINK1\_CUR\_STS 699  
SOF Timing Value 644  
Software Debug 638  
Software SMI# Timer Enable 503  
SP 560  
Space Type 708  
SPDH 418  
Speaker Data Enable 473  
Special Cycle Enable 397, 409, 425, 529, 601, 629, 649,  
686, 706, 758  
Special Fully Nested Mode 458  
Special Mask Mode 460  
Speed Allowed 595, 624  
SPI Read Configuration (SRC) 441  
SPI\_STS 504  
Spin-Up Device 591  
Square Wave Enable 471  
SS\_STATE 510  
SSFC 811, 833



SSFS 810, 832  
 SSTS 763  
 SSYNC 738  
 START 694  
 Start 591  
 Start Frame Pulse Width 431  
 Start/Stop Bus Master 565, 620  
 STATESTS 733  
 Static Bus Master Status Policy Enable 637  
 Status 592  
 STME 557  
 STRD 555  
 Stream Interrupt Enable 736  
 Stream Interrupt Status 737  
 Stream Number 746  
 Stream Reset 747  
 Stream Run 747  
 Stream Synchronization 738  
 Stripe Control 746  
 STTT1 557  
 STTT2 558  
 Sub Class Code 411, 427, 532, 631, 651, 688, 707, 760  
 Subordinate Bus Number 412, 762  
 Subsystem ID 428, 537, 607, 633, 653, 690, 709  
 Subsystem Identifier 422, 779  
 Subsystem Vendor ID 428, 536, 606, 633, 652, 690, 709  
 Subsystem Vendor Identifier 422, 779  
 Subtractive Decode Policy 421  
 Supports 64-bit Addressing 571  
 Supports Activity LED 571  
 Supports Aggressive Link Power Management 571  
 Supports Cold Presence Detect 571  
 Supports Command List Override (SCLO) 571  
 Supports Command Queue Acceleration 571  
 Supports Interlock Switch 571  
 Supports Non-Zero DMA Offsets 571  
 Supports Port Multiplier 571  
 Supports Port Multiplier FIS Based Switching 571  
 Supports Port Selector Acceleration 571  
 Supports Staggered Spin-up 571  
 Suspend 645, 679  
 SVCAP 779  
 SVID 401, 690, 709, 779  
 SW\_TCO\_SMI 513  
 SWGPE\_CTRL 508  
 SWGPE\_EN 501  
 SWGPE\_STS 499  
 SWSMI\_RATE\_SEL 480  
 SWSMI\_TMR\_STS 505  
 System Error on Correctable Error Enable 777

System Error on Fatal Error Enable 777  
 System Error on Non-Fatal Error Enable 777  
 System Reset 475  
 System Reset Status 478

## T

Target Component ID 792  
 Target Component ID (TCID) 358, 359, 360, 361, 362  
 Target Port Number 792  
 Target Port Number (PN) 358, 359, 360, 361, 362  
 Task File Error Enable 587  
 Task File Error Status 585  
 TCO 369  
 TCO Data In Value 512  
 TCO Data Out Value 512  
 TCO IRQ Select (IS) 369  
 TCO Timer Halt 515  
 TCO Timer Initial Value 517  
 TCO Timer Value 511  
 TCO\_EN 502  
 TCO\_INT\_STS 513  
 TCO\_LOCK 515  
 TCO\_MESSAGE(n) 516  
 TCO\_STS 505  
 TCOSCI\_EN 500  
 TCOSCI\_STS 499  
 TCSEL 711  
 TCTL 369  
 Thermal Interrupt Status 499  
 THRM#\_POL 508  
 THRM\_DTY 495  
 THRM\_EN 501  
 Throttle Status 494  
 THTL\_DTY 495  
 THTL\_EN 495  
 TIMEOUT 513  
 Timeout/CRC Interrupt Enable 642  
 Timer 0 Interrupt Active 797  
 Timer 1 Interrupt Active 797  
 Timer 2 Interrupt Active 797  
 Timer Compare Value 800  
 Timer Counter 2 Enable 473  
 Timer Counter 2 OUT Status 473  
 Timer Interrupt Rout Capability 798  
 Timer Interrupt Type 799  
 Timer n 32-bit Mode 799  
 Timer n Interrupt Enable 799  
 Timer n Size 799  
 Timer n Type 799  
 Timer n Value Set 799



Timer Overflow Interrupt Enable 492  
Timer Overflow Status 491  
Timer Value 494  
TIMn 800  
TOKEN\_PID\_CNT(7-0) 682  
Top Swap (TS) 388  
Top Swap Status (TSS) 441  
Traffic Priority 746  
Training 787  
Training Error Mask 788  
Training Error Severity 789  
Transaction Class / Virtual Channel Map 786  
Transaction Class / Virtual Channel Map (TVM) 355, 356  
Transactions Pending 718, 770  
Trap and SMI# Enable (TRSE) 368  
Trapped I/O Address (TIOA) 367  
Trapped I/O Data (TIOD) 367  
TRCR 367  
Trigger Mode 466  
TWDR 367  
Type 535, 652

**U**

UEM 788  
UES 787  
UEV 789  
UHCI #0 Pin (U0P) 372  
UHCI #1 Disable (U1D) 390  
UHCI #1 Pin (U1P) 372  
UHCI #2 Disable (U2D) 390  
UHCI #2 Pin (U2P) 372  
UHCI #3 Disable (U3D) 390  
UHCI #3 Pin (U3P) 372  
UHCI #4 Disable (U4D) 390  
UHCI v/s EHCI 204  
UHCI\_BREAK\_EN 484  
ULBA 358, 793  
ULD 358, 792  
Unexpected Completion Mask 788  
Unexpected Completion Severity 789  
Unexpected Completion Status 787  
Unimplemented Asynchronous Park Mode Bits 669  
Unique Clock Exit Latency 782  
Unknown FIS Interrupt 586  
Unknown FIS Interrupt Enable 587  
Unlocked 481  
Unsupported 788, 789  
Unsupported Request Detected 718, 770  
Unsupported Request Error Status 787  
Unsupported Request Reporting Enable 718, 769  
Update Cycle Inhibit 471  
Update In Progress 470  
Update-Ended Flag 472  
Update-Ended Interrupt Enable 471  
Upper 128 Byte Enable (UE) 385  
Upper 128 Byte Lock (UL) 385  
Upper Address(63-44) 675  
Upper Base Address 709  
Upstream Read Latency Threshold 421  
USB 636  
USB EHCI Dynamic Clock Gate Enable 392  
USB EHCI Static Clock Gate Enable 392  
USB Error Interrupt 641, 672  
USB Error Interrupt Enable 673  
USB Interrupt 641, 672  
USB Interrupt Enable 673  
USB Release Number 657  
USB UHCI Dynamic Clock Gate Enable 392  
USB\_ADDRESS\_CNF 683  
USB\_ENDPOINT\_CNF 683  
USB1\_EN 501  
USB1\_STS 499  
USB2 669, 671, 673  
USB2\_EN 501  
USB2\_STS 499  
USB3\_EN 500  
USB3\_STS 498  
USB4\_EN 500  
USB4\_STS 497  
USBPID 682  
Use SATA Class Code 551  
User Definable Features 530, 602, 630, 650, 687

**V**

V0CAP 354, 785  
V0CTL 355, 786  
V0STS 355, 786  
V1CTL 356  
V1STS 356  
Valid RAM and Time Bit 472  
VC Arbitration Capability (AC) 354  
VC Arbitration Select 785  
VC Arbitration Select (AS) 354  
VC Arbitration Table Offset 784  
VC Arbitration Table Offset (ATO) 354  
VC Arbitration Table Status 785  
VC Arbitration Table Status (VAS) 354  
VC Negotiation Pending 786  
VC Negotiation Pending (NP) 355, 357





VC0CAP 721  
 VCOCTL 721  
 VCOSTS 721  
 VCAP1 353  
 VCAP2 354, 784  
 VCCAP 719  
 VCH 353, 784  
 VciCAP 722  
 VciCTL 722  
 VciSTS 723  
 Vector 467  
 Vendor ID 396, 408, 424, 528, 600, 629, 648, 685, 705, 757  
 Vendor ID Capability 796  
 VER 465  
 Version 403, 465, 545, 615, 655, 714, 780  
 VGA 16-Bit Decode 417, 766  
 VGA Enable 417, 767  
 VGA Palette Snoop 397, 409, 425, 529, 601, 629, 649, 686, 706, 758  
 VID 396, 705  
 Virtual Channel Enable 786  
 Virtual Channel Enable (EN) 355, 356  
 Virtual Channel Identifier 786  
 Virtual Channel Identifier (ID) 355, 356  
 VMAJ 729  
 VMIN 729  
 VS 576  
 VSCC 816

## W

Wait Cycle Control 397, 409, 425, 529, 601, 629, 649, 686, 706, 758  
 Wake on Connect Enable 677  
 Wake on Disconnect Enable 677  
 Wake on Overcurrent Enable 677  
 Wake Status 490  
 WAKEEN 731

## A

A20Gate Pass-Through Enable 573  
 AC '97 Modem Disable (AMD) 305  
 AC '97 Static Clock Gate Enable 308  
 AC97\_EN 406  
 AC97\_STS 404  
 ACAZ\_BREAK\_EN 386  
 Accept Unsolicited Response Enable 672  
 ACPI Enable 329  
 Active State Link PM Control 715  
 Active State Link PM Control (APMC) 280  
 Active State Link PM Support 714

WALCLK 737  
 Wall Clock Counter 737  
 Write Granularity (WG) 816  
 Write Status Required (WSR) 816  
 WRITE\_READ#\_CNT 682  
 WRT\_RDONLY 663

## X

XCAP 768

## § §

(IOAD) 285  
 Interrupt Pending Status Port 516  
 EL\_STATE0\_CNT 388  
 EL\_STATE1\_CNT 388  
 Interrupt Pending Status Port 516  
 I/O Address 285  
 I/O Limit Address Limit bits 437  
 Interrupt Pending Status Port 516  
 GP\_BLINK 426, 427  
 GP\_IO\_SEL 424  
 Interrupt Pending Status Port 516  
 GP\_LVL 425, 430  
 GPIO\_USE\_SEL 424  
 GP\_IO\_SEL2 429  
 Upper Address 614  
 GP\_LVL 429  
 GPIO\_USE\_SEL2 428  
 64 Bit Address Capable 721  
 64 Bit Address Capable (C64) 483  
 64b Address Capability 655  
 64-bit Address Supported 670  
 64-bit Addressing Capability 606  
 64-bit Indicator 707  
 64-bit Indicator (I64B) 439  
 64-bit Indicator (I64L) 439  
 66 MHz Capable 312, 326, 438, 568, 588, 627, 647, 702  
 66MHz Capable 450, 468, 542  
 Address 285

Active State Link PM Support (APMS) 279  
 Active-high Byte Enables (AHBE) 284  
 Address 635, 721  
 Address (ADDR) 485  
 Address Enable (AE) 300  
 Address Increment/Decrement Select 349  
 Address of Descriptor Table 463, 505, 558  
 Address Select (AS) 300  
 Address Translator Enable 725  
 ADI 357  
 Advanced Error Interrupt Message Number 737



Advanced Packet Switching 730  
Advanced Packet Switching (APS) 269, 271  
AECC 736  
AFTERG3\_EN 382  
Aggressive Link Power Management Enable 529  
Aggressive Slumber / Partial 529  
AHCI Enable 515  
Alarm Flag 373  
Alarm Interrupt Enable 372  
Alternate A20 Gate 375  
Alternate Access Mode Enable (AME) 302  
Alternate GPI SMI Enable 411  
Alternate GPI SMI Status 412  
APIC Data 365  
APIC Enable (AEN) 299  
APIC ID 366  
APIC Index 364  
APM\_STS 411  
APMC\_EN 408  
Arbiter Disable 401  
Asynchronous Schedule Enable 608  
Asynchronous Schedule Park Capability 606

## B

B2/B3 Support 654, 724  
Bad DLLP Mask 736  
Bad DLLP Status 735  
Bad TLP Mask 736  
Bad TLP Status 735  
BAR Location (BARLOC) 497  
BAR Number 595  
BAR Offset (BAROFST) 497  
Base Address 328, 329, 343, 452, 453, 454, 471, 472, 473, 474, 544, 545, 546, 570, 581, 590, 629, 707  
Base Address (Low) 614  
Base Address Lower 739  
Base Address Lower (BAL) 274  
Base Address Upper 739  
Base Address Upper (BAU) 274  
Base and Current Address 345  
Base and Current Count 346  
Base Class Code 313, 314, 315, 316, 327, 435, 452, 470, 543, 569, 589, 628, 648, 703, 704  
BATLOW\_EN 405  
BATLOW\_STS 403  
BCC 569, 648, 703  
BCTRL 709  
BFCS 499  
BFTD1 501  
BFTD2 501  
Bidirectional Direction Control 688  
Binary/BCD Countdown Select 353  
BIOS Interface Lock-Down (BILD) 302  
BIOS Lock Enable 341  
BIOS Release 407  
BIOS Write Enable 341  
BIOS\_EN 408

Asynchronous Schedule Status 610  
ASYNCLISTADDR 615  
ATS 461  
Attention Button Present 657, 711, 717  
Attention Button Pressed 719  
Attention Button Pressed Enable 719  
Attention Indicator Control 718  
Attention Indicator Present 657, 711, 717  
Auto Flush After Disconnect Enable 443  
Autoinitialize Enable 349  
Automatic End of Interrupt 359  
Automatically Append CRC 638  
Aux Current 654  
AUX Power Detected 659, 713  
Aux Power PM Enable 712  
Aux\_Current 317, 723  
Auxiliary Current 482, 552, 593  
Auxiliary Power Enable 658  
Azalia Pin (ZIP) 291  
Azalia Traffic Class Assignment 652  
Azalia/AC '97 Signal Mode 651

BIOS\_PCI\_EXP\_EN 378  
BIOS\_STS 411  
BIOSWR\_STS 418  
BIST FIS Failed 500  
BIST FIS Parameters 500  
BIST FIS Successful 499  
BIST FIS Transmit Data 1 501  
BIST FIS Transmit Data 2 501  
Bits per Sample 694  
Block Data 636  
Block Delayed Transactions 443  
Block/Sector Erase Size (BSES) 762  
BM\_BREAK\_EN 386  
BME Receive Check Enable 725  
BNUM 704  
Boot BIOS Straps (BBS) 301  
BOOT\_STS 419  
BUC 303  
Buffer Completion Interrupt Status 690  
Buffer Descriptor List Pointer Lower Base Address 695  
Buffer Descriptor List Pointer Upper Base Address 695  
Buffered Mode 359  
Bus Master Enable 311, 325, 433, 449, 467, 541, 567, 587, 626, 646, 701  
Bus Master IDE Active 463, 504, 558  
Bus Master Reload 397  
Bus Master Status 395  
Bus Number (BN) 274, 275, 276, 277, 278  
Bus Power / Clock Control Enable 724  
Bus Power/Clock Control Enable 654  
BUS\_ERR 632  
Byte Done Status 632  
Byte Enable Mask (BEM) 285  
Byte Enables (TBE) 285



## C

C3\_RESIDENCY 414, 415  
 C4 385  
 Cache Line Size 452  
 CAP 513  
 Cap 656  
 Cap ID 653, 655  
 Capabilities List 312, 326, 435, 468, 542, 568, 588, 647, 702  
 Capabilities List Indicator 627  
 Capabilities Pointer 316, 474, 546, 591, 650, 708  
 Capabilities Pointer (PTR) 440  
 Capability 273, 729  
 Capability ID 317, 318, 319, 481, 552, 597, 710, 721, 729, 737  
 Capability ID (CAP) 496  
 Capability ID (CID) 268, 273, 279, 483  
 Capability Identifier 446, 722  
 Capability Register Length Value 604  
 Capability Version 657, 710, 737  
 Capability Version (CV) 268, 279  
 CAPLENGTH 604  
 CAPP 316, 708  
 CAPPTR 650  
 Captured Slot Power Limit Scale 657, 711  
 Captured Slot Power Limit Value 657, 711  
 Cascaded Interrupt Controller IRQ Connection 358  
 CC 313  
 CCC\_CTL 518  
 CCC\_Ports 519  
 CEM 736  
 CES 735  
 CG 306  
 Channel Mask Bits 351  
 Channel Mask Select 348  
 Channel Request Status 347  
 Channel Terminal Count Status 347  
 CIR6 286  
 CIR7 286  
 Clear Byte Pointer 350  
 Clear Mask Register 351  
 CLIST 317, 319, 710  
 CLS 313, 648, 704  
 CNF1\_LPC\_EN 334  
 CNF2\_LPC\_EN 334  
 CNTL\_STS 621  
 Cold Port Detect Status 526  
 Cold Presence Detect Enable 527  
 COMA Decode Range 333  
 COMA\_LPC\_EN 334  
 COMB Decode Range 333  
 COMB\_LPC\_EN 334  
 Command Completed 719  
 Command Completed Interrupt Enable 718  
 Command List Base Address 524  
 Command List Base Address Upper 524, 525  
 Command List Override (CLO) 531  
 Commands Issued 537  
 Common Clock Configuration 715  
 Common Clock Exit Latency 726  
 Completion 732  
 Completion Abort Mask 733  
 Completion Abort Severity 734  
 Completion Abort Status 732  
 Completion Timeout Mask 733  
 Completion Timeout Severity 734  
 Component ID 738  
 Component ID (CID) 273  
 CONFIG 623  
 CONFIGFLAG 615  
 Configuration Layout 570, 704  
 Configure Flag 576, 615  
 Connect Status Change 584, 620  
 Controller Interrupt Enable 677  
 Controller Interrupt Status 678  
 Controller Reset 672  
 Controller Running 530  
 Coprocessor Error 376, 728  
 Coprocessor Error Enable (CEN) 299  
 CORB Lower Base Address 680, 682  
 CORB Memory Error Indication 682  
 CORB Memory Error Interrupt Enable 681  
 CORB Read Pointer (CORBRP) 681  
 CORB Read Pointer Reset 681  
 CORB Size 682  
 CORB Size Capability 682  
 CORB Upper Base Address 680  
 CORB Write Pointer 680  
 CORBCTL 681  
 CORBLBASE 680  
 CORBRP 681  
 CORBSIZE 682  
 CORBST 682  
 CORBUBASE 680  
 CORBWP 680  
 Correctable Error Detected 659, 713  
 Correctable Error Reporting Enable 658, 712  
 Count Register Status 355  
 Countdown Type Status 355  
 Counter 0 Select 354  
 Counter 1 Select 354  
 Counter 2 Select 354  
 Counter Latch Command 354  
 Counter Mode Selection 353  
 Counter OUT Pin State 355  
 Counter Port 356  
 Counter Select 353  
 Counter Selection 354  
 Counter Size Capability 742  
 Counter Value 744  
 CPU BIST Enable (CBE) 303  
 CPU PLL Lock Time 380  
 CPU Power Failure 381  
 CPU SLP# Enable 379  
 CPU Thermal Trip Status 380  
 CRC Error 637  
 CTRLDSSEGMENT 614



Current Command Slot 531  
Current Connect Status 584, 620  
Current Interface Speed 506, 533, 559

## D

D1 Support 482, 552, 593, 654  
D1\_Support 317, 723  
D2 Support 482, 552, 593, 654  
D2\_Support 317, 723  
D27IP 291  
D28IP 290  
D28IR 295  
D29IP 289  
D29IR 293  
D30IP 289  
D30IR 293  
D31IR 292  
DAT 365  
Data 490, 498, 654, 722  
Data (DATA) 510, 511, 563  
DATA Cycle— RW 748, 749, 751, 752, 753, 754, 757, 761, 762, 777, 778, 780, 782, 783, 785  
Data Link Layer Active (DLLA) 716  
Data Link Protocol Error Mask 733  
Data Link Protocol Error Severity 734  
Data Link Protocol Error Status 732  
Data Message Byte 0 637  
Data Message Byte 1 637  
Data Mode 372  
Data Parity Error Detected 326, 435, 438, 450, 468, 542, 568, 627, 647, 706  
Data Scale 594  
Data Select 594  
DATA\_HIGH\_BYTE 641  
DATA\_LEN\_CNT 622  
DATA\_LOW\_BYTE 641  
Data0/Count 635  
Data1 635  
DATABUF 623  
DATABUFFER(63-0) 623  
Date Alarm 373  
Daylight Savings Enable 372  
DCAP 711  
DCTL 712  
Debug Port Capability ID 595  
Debug Port Number 605  
Debug Port Offset 595  
Delivery Mode 368  
Delivery Status 367  
Descriptor Error 690  
Descriptor Error Interrupt Enable 688  
Descriptor Processed 526  
Descriptor Processed Interrupt Enable 528  
Destination 367  
Destination Mode 368  
Detected Parity Error 312, 325, 433, 438, 450, 468, 542, 568, 588, 627, 647, 702, 706  
DEV\_ERR 632  
Cx 384  
Cycle Trap SMI# Status (CTSS) 284  
Cyclic Buffer Length 691  
DEVC 658  
DEVCAP 657  
Device / Port Type 710  
Device Connects 218  
Device Detection 506, 533, 559  
Device Detection Initialization 507, 534, 560  
Device ID 310, 324, 432, 448, 467, 541, 566, 586, 626, 645, 700  
Device Interlock Enable 528  
Device Interlock Status 526  
Device Monitor Status 410  
Device Number (DN) 274, 275, 276, 277, 278  
Device Specific Initialization 317, 482, 552, 593, 654, 723  
Device Status 537  
Device to Host Register FIS Interrupt Enable 528  
DEVICE\_ADDRESS 640  
Device/Port Type 657  
DEVS 659  
DEVSEL# Timing Status 312, 326, 438, 450, 468, 542, 568, 588, 627, 647, 702  
Diagnostics 508, 535, 561  
DID 310, 645  
Discard Delayed Transactions 443  
Discard Timer SERR# Enable 441, 709  
Discard Timer Status 441, 709  
Division Chain Select 371  
DMA 687  
DMA Channel Group Enable 347  
DMA Channel Select 348, 349  
DMA Group Arbitration Priority 347  
DMA Low Page 346  
DMA Position Buffer Enable 687  
DMA Position Lower Base Address 687  
DMA Position Upper Base Address 687  
DMA Setup FIS Interrupt 527  
DMA Setup FIS Interrupt Enable 528  
DMA Transfer Mode 349  
DMA Transfer Type 349  
DMC 286  
DMI and PCI Express\* RX Dynamic Clock Gate Enable 307  
DMI TX Dynamic Clock Gate Enable 307  
DMISCI\_STS 417  
DMISERR\_STS 417  
DMISMI\_STS 417  
Dock Attach (DA) 652  
Dock Mated (DM) 653, 674  
Dock Mated Interrupt Status (DMIS) 674  
Docking Supported (DS) 675  
Docking Supported (DS) - R/WO 653  
DONE\_STS 621



DPLBASE 687  
 DPRSLPVR to STPCPU 385  
 DPSP-LP-TO-SLP 385  
 DPUBASE 687  
 DR 318  
 DRAM Initialization Bit 380  
 Drive 0 DMA Capable 463, 504, 527, 558  
 Drive 0 DMA Timing Enable 456, 476, 548  
 Drive 0 Fast Timing Bank 456, 476, 548  
 Drive 0 IORDY Sample Point Enable 456, 476, 548

Drive 0 Prefetch/Posting Enable 456, 476, 548  
 Drive 1 DMA Capable 463, 504, 558  
 Drive 1 DMA Timing Enable 456, 476, 548  
 Drive 1 Fast Timing Bank 456, 476, 548  
 Drive 1 IORDY Sample Point Enable 456, 476, 548  
 Drive 1 Prefetch/Posting Enable 456, 476, 548  
 Drive 1 Timing Register Enable 455, 475, 547  
 Drive LED on ATAPI Enable 529  
 DSTS 713

## E

ECAP 675  
 ECRC 736  
 ECRC Check Capable 736  
 ECRC Check Enable 736  
 ECRC Error Mask 733  
 ECRC Error Severity 734  
 ECRC Error Status 732  
 ECRC Generation Enable 736  
 Edge/Level Bank Select (LTIM) 357  
 EHC Initialization 213  
 EHC Resets 214  
 EHCI Disable (EHCID) 304  
 EHCI Extended Capabilities Pointer 606  
 EHCI Pin (EIP) 289  
 EHCI\_BREAK\_EN 386  
 EL\_EN—R/W  
 389  
 EL\_LED\_OWN—R/W  
 388  
 EL\_PB\_SCI\_STS - R/WC 387  
 EL\_PB\_SMI\_STS - R/WC  
 387  
 EL\_SCI\_EN — R/W 405  
 EL\_SCI\_NOW\_STS- R/WC  
 387  
 EL\_SCI\_STS — R/WC 403  
 EL\_SMI\_EN — R/W 407  
 EL\_SMI\_STS — RO 409  
 Element Type 738  
 Element Type (ET) 273  
 EM\_CTL 520

EM\_LOC 519  
 Enable 343  
 Enable 32-Byte Buffer 638  
 Enable CORB DMA Engine 681  
 Enable No Snoop 712  
 Enable Relaxed Ordering 658, 712  
 Enable RIRB DMA Engine 684  
 Enable Special Mask Mode 361  
 ENABLED\_CNT 621  
 End of SMI 408  
 Endpoint L0 Acceptable Latency 711  
 Endpoint L0s Acceptable Latency 657  
 Endpoint L1 Acceptable Latency 657, 711  
 Enter C4 When C3 Invoked 378  
 Enter Global Suspend Mode 576  
 EOIR 365  
 Erase Opcode 762  
 ERBA 316  
 ERR\_COR Received 737  
 ERR\_FATAL/NONFATAL Received 737  
 Error 463, 504, 509, 532, 536, 558, 562  
 ERROR\_GOOD#\_STS 621  
 ESD 273, 664, 738  
 EXCEPTION\_STS 621  
 Extended Destination ID 367  
 Extended Synch 715  
 Extended Synch (ES) 280  
 Extended Tag Field Enable 658, 712  
 Extended Tag Field Support 657  
 Extended Tag Field Supported 711  
 Extended VC Count (EVC) 268

## F

FADDR 751, 780  
 FAILED 632  
 Fast Back to Back Capable 312, 326, 435, 438, 450,  
 468, 542, 568, 588, 627, 647, 702  
 Fast Back to Back Enable 311, 325, 432, 441, 449,  
 467, 541, 567, 626, 646, 701, 709  
 Fast Primary Drive 0 Base Clock 460, 481, 551  
 Fast Primary Drive 1 Base Clock 460, 481, 551  
 Fast Secondary Drive 0 Base Clock 480, 551  
 Fast Secondary Drive 1 Base Clock 480, 551  
 Fatal Error Detected 659, 713  
 Fatal Error Reporting Enable 658, 712

FB\_40\_EN 340  
 FB\_40\_IDSEL 338  
 FB\_50\_EN 340  
 FB\_50\_IDSEL 338  
 FB\_60\_EN 340  
 FB\_60\_IDSEL 338  
 FB\_70\_EN 339  
 FB\_70\_IDSEL 338  
 FB\_CO\_EN 339  
 FB\_CO\_IDSEL 337  
 FB\_C8\_EN 339  
 FB\_C8\_IDSEL 337



FB\_DO\_EN 339  
FB\_DO\_IDSEL 337  
FB\_D8\_EN 339  
FB\_D8\_IDSEL 337  
FB\_E0\_EN 339  
FB\_E0\_IDSEL 337  
FB\_E8\_EN 338  
FB\_E8\_IDSEL 337  
FB\_F0\_EN 338  
FB\_F0\_IDSEL 337  
FB\_F8\_EN 338  
FB\_F8\_IDSEL 337  
FDATA0 751, 780  
FDATAN 751  
FDD Decode Range 333  
FDD\_LPC\_EN 334  
FDOC 761  
FDOD 761  
FERR# MUX Enable (FME) 301  
FIFO Error 690  
FIFO Error Interrupt Enable 688  
FIFO Ready 690  
FIFO Size 693  
FIFO Watermark 692  
First Error Pointer 736  
FIS Base Address 525  
FIS Receive Enable 531

FIS Receive Running 530  
FLCOMP 765  
FLILL 766  
Flow Control Protocol Error Mask 733  
Flow Control Protocol Error Severity 734  
Flow Control Protocol Error Status 732  
FLREG0 767  
Flush Control 672  
Flush Status 674, 760, 788  
FLVALSIG 763  
Force Global Resume 576  
Force Port Resume 619  
Force Thermal Throttling 398  
Frame Length Timing Value 596  
Frame List Current Index/Frame Number 580, 613  
Frame List Rollover 611  
Frame List Rollover Enable 612  
Frame List Size 609  
FRAP 752, 781  
FREG0 752, 782  
FREG1 753, 782  
FREG2 753, 783  
FREG3 754, 783  
FRINDEX 613  
Full Reset 376  
Function Number (FN) 274, 275, 276, 277, 278

## G

GAMEH\_LPC\_EN 334  
GAMEL\_LPC\_EN 334  
GBL\_SMI\_EN 408  
GC 330  
GCAP 670  
GCAP\_ID 742  
GCS 301  
GCTL 672  
GEN\_CONF 743  
Generic Decode Range 1 Enable 335, 336  
Generic I/O Decode Range 1 Base Address 335, 336  
GHC 515  
GINTR\_STA 743  
Global Enable 396  
Global Interrupt Enable 677  
Global Interrupt Status 678  
Global Release 397  
Global Reset 577

Global Status 394  
GO\_CNT 622  
GP\_INV(n) 428  
GP\_IO\_SEL2 429  
GP\_LVL2 429  
GPE0\_STS 410  
GPIIn\_EN 405  
GPIIn\_STS 402  
GPIO Enable 330  
GPIO\_USE\_SEL2 428  
GPIO0 Route 389  
GPIO1 Route 389  
GPIO11\_ALERT\_DISABLE 421  
GPIO15 Route 389  
GPIO2 Route 389  
GPIOBASE 329  
GSTS 674

## H

HBA Reset 515  
HC BIOS Owned Semaphore 597  
HC OS Owned Semaphore 597  
HCCPARAMS 606  
HCHalted 579, 610  
HCIVERSION 604  
HCSPARAMS 605  
HDBA 277

HDBARL 649  
HDBARU 649  
HDCTL 651  
HDD 277  
HDevice is ATAPI 530  
Header Type 327, 436, 648, 649  
HEADTYP 327, 649  
Hide Device 0 442



Hide Device 1 442  
 Hide Device 2 442  
 Hide Device 3 442  
 High Definition Audio Dynamic Clock Gate Enable 306  
 High Definition Audio Static Clock Gate Enable 306  
 High Priority Port (HPP) 282  
 High Priority Port Enable (HPE) 282  
 Host Bus Data Error Enable 527  
 Host Bus Data Error Status 526  
 Host Bus Fatal Error Enable 527  
 Host Bus Fatal Error Status 526  
 Host Controller Process Error 579  
 Host Controller Reset 577, 609  
 Host System Error 579, 611  
 Host System Error Enable 612  
 HOST\_BUSY 633  
 HOST\_NOTIFY\_INTREN 640  
 HOST\_NOTIFY\_STS 639  
 HOST\_NOTIFY\_WKEN 640

**I**

I/O Base Address 705  
 I/O Base Address (IOBA) 437  
 I/O Base Address Capability 437, 705  
 I/O Limit Address 705  
 I/O Limit Address Capability 705  
 I/O Space Enable 311, 325, 433, 449, 467, 541, 567,  
 587, 626, 646, 701  
 I2C 228  
 I2C\_EN 630  
 i64\_EN 379  
 IC 685  
 ICW/OCW Select 357  
 ICW4 Write Required 357  
 ID 366  
 IDE Decode Enable 455, 457, 475, 547  
 IDE\_ACT\_STS 413  
 IDE\_BREAK\_EN 386  
 IDE\_TIMS 457  
 I/O Limit Address Capability 437  
 ILCL 279  
 Immediate Command Busy 686  
 Immediate Command Write 685  
 Immediate Response Read 686  
 Immediate Result Valid 686  
 IN\_USE\_CNT 621  
 Incorrect Port Multiplier Enable 528  
 Incorrect Port Multiplier Status 526  
 IND 364  
 Index (INDEX) 509, 510, 563  
 INIT\_NOW 375  
 INPAY 671  
 Input FIFO Padding Type (IPADTYPE) 676  
 Input Payload Capability 671  
 Input Stream Payload Capability (INSTRMPAY) 676  
 INSTRMPAY 676  
 INTCTL 677  
 Intel 291, 305  
 Hot Plug Attention Button SMI Status 727  
 Hot Plug Capable 717  
 Hot Plug Capable Port 530  
 Hot Plug Command Completed SMI Status 727  
 Hot Plug Interrupt Enable 718  
 Hot Plug Link Active State Changed SMI Status (HPLAS)  
 727  
 Hot Plug Presence Detect SMI Status 727  
 Hot Plug SCI Enable 725  
 Hot Plug SCI Status 727  
 Hot Plug SMI Enable 726  
 Hot Plug Surprise 717  
 HOT\_PLUG\_EN 406  
 HOT\_PLUG\_STS 404  
 Hour Format 372  
 HPTC 300  
 HSFC 750, 779  
 HSFS 749, 778  
 HT 313  
 Intel PRO/Wireless 3945ABG Status 728  
 Intel SpeedStep Enable 379  
 INTEL\_USB2\_EN 407  
 INTEL\_USB2\_STS 409  
 Interface 469, 470, 543  
 Interface Communication Control 529  
 Interface Fatal Error Status 526  
 Interface Non-fatal Error Enable 527  
 Interface Non-fatal Error Status 526  
 Interface Power Management 506, 533, 559  
 Interface Power Management Transitions Allowed 507,  
 534, 560  
 Interface Speed Support 514  
 Interlock Switch Attached to Port 530  
 Interlock Switch State 531  
 Interrupt 463, 504, 558  
 Interrupt A Pin Route (IAR) 293, 294, 295, 296, 297,  
 298  
 Interrupt B Pin Route (IBR) 294, 295, 296, 297, 298  
 Interrupt C Pin Route (ICR) 292, 293, 295, 296, 297,  
 298  
 Interrupt D Pin Route (IDR) 292, 293, 295, 296  
 Interrupt Disable 311, 432, 449, 467, 541, 567, 587,  
 626, 646, 701  
 Interrupt Enable 515  
 Interrupt Input Pin Polarity 367  
 Interrupt Level Select 360  
 Interrupt Line 316, 440, 455, 475, 547, 571, 591,  
 630, 651, 709  
 Interrupt Message Number 657, 710  
 Interrupt on Async Advance 610  
 Interrupt on Async Advance Doorbell 608  
 Interrupt on Async Advance Enable 612  
 Interrupt on Complete Enable 580  
 Interrupt on Completion Enable 688  
 Interrupt PIN 630  
 Interrupt Pin 316, 440, 455, 475, 547, 591, 651, 709



Interrupt Request Flag 373  
Interrupt Request Level 358  
Interrupt Request Mask 360  
Interrupt Rout 744  
Interrupt Routing Enable 330, 332  
Interrupt Status 312, 326, 435, 450, 468, 542, 568,  
588, 627, 647, 702  
Interrupt Threshold Control 608  
Interrupt Vector Base Address 358  
INTLN 651  
INTPN 651  
INTR 316, 633, 709  
INTRD\_SEL 421  
INTREN 634  
Intruder Detect 420  
INTSTS 678  
INUSE\_STS 632  
Invalid Receive Range Check Enable 725  
IO Space Indicator 629  
IOBL 705  
IOCHK# NMI Enable 374

IOCHK# NMI Source Status 374  
IORDY Sample Point 455, 475, 547  
IR 686  
IRQ Routing 330, 332  
IRQ1\_CAUSE 422  
IRQ10 ECL 363  
IRQ11 ECL 363  
IRQ12 ECL 363  
IRQ12\_CAUSE 422  
IRQ14 ECL 363  
IRQ15 ECL 363  
IRQ3 ECL 362  
IRQ4 ECL 362  
IRQ5 ECL 362  
IRQ6 ECL 362  
IRQ7 ECL 362  
IRQ9 ECL 363  
IRS 686  
IS 516  
ISA Enable 442, 710  
Isochronous Scheduling Threshold 606

## K

KBC\_ACT\_STS 413  
KBC\_LPC\_EN 334

KILL 634

## L

LOs Exit Latency 714  
LOs Exit Latency (ELO) 279  
L1 Exit Latency 714  
L1 Exit Latency (EL1) 279  
L1ADDL 665  
L1ADDU 665  
L1DESC 664  
Last Valid Index 692  
LAST\_BYTE 633  
Latch Count of Selected Counters 354  
Latch Status of Selected Counters 354  
Latency Count 704  
Latency Timer 648  
LCAP 279, 713  
LCTL 280, 715  
LDCR1 321  
LDCR2 321  
LDR1 321  
LDR2 322  
Legacy (LPC) Dynamic Clock Gate Enable 306  
Legacy Replacement Rout 743  
Legacy Replacement Rout Capable 742  
LEGACY\_USB\_EN 408  
LEGACY\_USB\_STS 411  
LEGACY\_USB2\_EN 407  
LEGACY\_USB2\_STS 409  
Light Host Controller Reset 608  
Line Status 583, 617  
Link 276, 277, 278  
Link Active Changed Enable (LACE) 718

Link Active Reporting Capable (LARC) 713  
Link Active State Changed (LASC) 719  
Link Disable 715  
Link Hold Off 725  
Link Pointer Low 615  
Link Position in Buffer 691  
Link Speed 716  
Link Speed (LS) 280  
Link Training 716  
Link Training Error 716  
Link Type 738  
Link Type (LT) 273, 274, 275, 277  
Link Valid 738  
Link Valid (LV) 273, 274, 275, 276, 277, 278  
LINK\_ID\_STS 621  
Load Port Arbitration Table 731  
Load Port Arbitration Table (LAT) 270, 271  
Load VC Arbitration Table 729  
Load VC Arbitration Table (LAT) 269  
Loop Back Test Mode 576  
Low Priority Extended VC Count (LPEVC) 268  
Low Speed Device Attached 583  
Lower 128 Byte Lock (LL) 299  
Lower Base Address 649  
LPC Bridge Disable (LBD) 304  
LPC\_I 333  
LPT Decode Range 333  
LPT\_LPC\_EN 334  
LSTS 280, 716  
LT 648





## M

MA 721  
 MADDH 320  
 MADDL 319  
 Main Counter Tick Period 742  
 MAIN\_CNT 744  
 Major Revision (MAJREV) 496  
 Major Version 670  
 Major Version Number 518  
 Malformed TLP Mask 733  
 Malformed TLP Severity 734  
 Malformed TLP Status 732  
 Map Value 486, 553  
 Mask 367  
 Mask (ADMA) 285  
 Master Abort Mode 441, 709  
 Master Abort Status 325  
 Master Clear 350  
 Master Data Parity Error Detected 312, 588, 702  
 Master Latency Count 327  
 Master Latency Timer 569  
 Master Latency Timer Count 436, 437, 452, 471, 543, 590  
 Master Trap 461  
 Master/Slave in Buffered Mode 359  
 Max Packet 576  
 Max Payload Size 658, 712  
 Max Payload Size Supported 657, 711  
 Max Read Request Size 658, 712  
 Maximum Delayed Transactions 443  
 Maximum Link Speed 714  
 Maximum Link Speed (MLS) 279  
 Maximum Link Width 714  
 Maximum Link Width (MLW) 279  
 Maximum Redirection Entries 366  
 Maximum Time Slots 730  
 Maximum Time Slots (MTS) 269, 271  
 MBARA 314  
 MBARB 314  
 MBARC 315  
 MBL 707  
 MC 721  
 MC\_LPC\_EN 334  
 MCSMI\_EN Microcontroller SMI Enable 407  
 MCTL 319  
 MD 722  
 MDAT 320  
 Memory Base 439, 707  
 Memory Limit 439, 707  
 Memory Read Line Prefetch Disable 444  
 Memory Read Multiple Prefetch Disable 444  
 Memory Read Prefetch Disable 444  
 Memory Space Enable 311, 325, 433, 449, 467, 541, 567, 587, 626, 646, 701  
 Memory Write and Invalidate Enable 433, 646  
 Message Data 656  
 Message Lower Address 656  
 Message Upper Address 656  
 Microcontroller SMI# Status 410  
 Microprocessor Mode 359  
 MID 655, 721  
 Minimum SLP\_S4# Assertion Width Violation Status 381  
 Minor Revision (MINREV) 496  
 Minor Version 670, 748, 749, 750, 751, 752, 753, 754, 755, 756, 757, 758, 761, 777, 778, 779, 780, 781, 782, 783, 784, 785, 786  
 Minor Version Number 518  
 MLMG 316  
 MMC 655  
 MMD 656  
 MMLA 656  
 MMUA 656  
 Mobile IDE Configuration Lock Down (MICLD) 301  
 Mode Selection Status 355  
 MONITOR\_STS 409  
 MPC 725  
 MRL Sensor Changed 719  
 MRL Sensor Changed Enable 719  
 MRL Sensor Present 717  
 MRL Sensor State 719  
 MSI Enable 655, 721  
 MSI Enable (MSIE) 484  
 Multi-Function Device 327, 436, 570, 704  
 Multiple ERR\_COR Received 737  
 Multiple ERR\_FATAL/NONFATAL Received 737  
 Multiple Message Capable 655, 721  
 Multiple Message Capable (MMC) 484  
 Multiple Message Enable 655, 721  
 Multiple Message Enable (MME) 484

## N

N Response Interrupt Count 684  
 N\_PORTS 605  
 Negotiated Link Width 716  
 Negotiated Link Width (NLW) 280  
 Never Prefetch 443  
 NEWCENTURY\_STS 418  
 Next Capability 317, 319, 320, 321, 322, 446, 481, 552, 653, 655, 656, 710, 722, 737  
 Next Capability (NEXT) 273  
 Next Capability Offset 729  
 Next Capability Offset (NCO) 268  
 Next Capability Offset (NEXT) 279  
 Next Capability Pointer (NEXT) 496  
 Next EHCI Capability Pointer 597  
 Next Item Pointer 1 Value 592  
 Next Item Pointer 2 Capability 595  
 Next Pointer 721  
 Next Pointer (NEXT) 483



NMI Enable 375  
NMI\_NOW 421  
NMI2SMI\_EN 420  
NMI2SMI\_STS 418  
No Reboot (NR) 302  
No Snoop Enable 658  
Non-Fatal Error Detected 659, 713  
Non-Fatal Error Reporting Enable 658, 712  
NOTIFY\_DADDR 640  
NOTIFY\_DHIGH 641  
NOTIFY\_DLOW 641  
Number of Active Transactions 444  
Number of Bidirectional Stream Supported 670

## O

OCW2 Select 360  
OCW3 Select 361  
OIC 299  
OPMENU 760, 788  
OPTYPE 759, 787  
OS\_POLICY 421  
OUTPAY 671  
Output FIFO Padding Type (OPADTYPE) 675  
Output Payload Capability 671

## P

Parity Error Response 311, 325, 432, 449, 467, 541, 567, 587, 626, 646, 701  
Parity Error Response Enable 442, 710  
Partial State Capable 514  
Pass Through State 573  
PATA Dynamic Clock Gate Enable 306  
PATA Pin (SMIP) 288  
PATA Reset State (PRS) 303  
PC 654  
PCI 289  
PCI Bridge Pin (PIP) 288  
PCI CLKRUN# Enable 379  
PCI Dynamic Gate Enable 306  
PCI Express #1 Pin (P1IP) 290  
PCI Express #2 Pin (P2IP) 290  
PCI Express #3 Pin (P3IP) 290  
PCI Express #4 Pin (P4IP) 290  
PCI Express 1 Disable (PE1D) 304  
PCI Express 2 Disable (PE2D) 304  
PCI Express 3 Disable (PE3D) 304  
PCI Express 4 Disable (PE4D) 304  
PCI Express Root Port Static Clock Gate Enable 307  
PCI Express TX Dynamic Clock Gate Enable 307  
PCI Express Wake Disable 396  
PCI Express Wake Status 393  
PCI Interrupt Enable 572  
PCI SERR# Enable 374  
PCI\_BREAK\_EN 386  
PCI\_EXP\_EN 406  
PCI\_EXP\_SMI\_STS 409  
PCI\_EXP\_STS 403

Number of Channels 694  
Number of Companion Controllers 605  
Number of Input Stream Supported 670  
Number of Link Entries 738  
Number of Link Entries (NLE) 273  
Number of Output Stream Supported 670  
Number of Pending Transactions 444  
Number of Ports 514  
Number of Ports per Companion Controller 605  
Number of Serial Data Out Signals 670  
Number of Timer Capability 742  
nvalid Receive Bus Number Check Enable 725

Output Stream Payload Capability (OUTSTRMPAY) 675  
OUTSTRMPAY 675  
Overall Enable 743  
Overcurrent Active 583, 619  
Overcurrent Change 619  
Overcurrent Indicator 583  
Overflow Error Enable 527  
Overflow Status 526  
OWNER\_CNT 621

PCICMD 311, 646  
PCI\_BREAK\_EN 386  
PCISTS 312, 647  
PCS 654  
PEC\_DATA 636  
PEC\_EN 633  
Peer Decode Enable 446  
PEETM 739  
Periodic Interrupt Capable 745  
Periodic Interrupt Enable 372  
Periodic Interrupt Flag 373  
Periodic Schedule Enable 609  
Periodic Schedule Status 610  
Periodic SMI# Rate Select 379  
PERIODIC\_EN 407  
PERIODIC\_STS 410  
PERIODICLISTBASE 614  
PERR# Assertion Detected 444  
PERR#-to-SERR# Enable 445  
Phantom 712  
Phantom Function Enable 658  
Phantom Functions Supported 657, 711  
PhyRdy 528  
PhyRdy Change Status 526  
Physical Slot Number 717  
PI 451, 517, 628, 648  
PID 653  
PIO Multiple DRQ Block (PMD) 514  
PIO Setup FIS Interrupt 527  
PIO Setup FIS Interrupt Enable 528  
PIRQAE\_ACT\_STS 413



PIROBF\_ACT\_STS 413  
 PIRQCG\_ACT\_STS 413  
 PIRODH\_ACT\_STS 413  
 PLT 313, 327  
 PM1\_STS\_REG 410  
 PMBL 707  
 PMBU32 708  
 PMC 317, 723  
 PMCAP 722  
 PMCS 318, 724  
 PME Clock 317, 482, 552, 593, 654, 723  
 PME Enable 318, 482, 553, 594, 654, 724  
 PME Interrupt Enable 720  
 PME Pending 720  
 PME Requestor ID 720  
 PME Status 318, 482, 553, 594, 654, 720, 724  
 PME Support 482, 552, 593, 654  
 PME\_BO\_EN 405  
 PME\_BO\_STS 402  
 PME\_EN 405  
 PME\_STS 403  
 PME\_Support 317, 723  
 PMLT 452  
 PMLU32 708  
 Poisoned TLP Mask 733  
 Poisoned TLP Severity 734  
 Poisoned TLP Status 732  
 Poll Mode Command 361  
 POP\_MODE\_CAP 451  
 POP\_MODE\_SEL 451  
 Popdown Mode Enable 383, 384  
 Popup Mode Enable 384  
 Port 492, 493, 495  
 Port 0 BIST FIS Initiate 500  
 Port 0 Enabled 488, 554  
 Port 0 Present 488, 554  
 Port 1 BIST FIS Initiate 500  
 Port 1 Enabled 488, 554  
 Port 1 Present 487, 554  
 Port 2 BIST FIS Initiate 499  
 Port 2 Enabled 488  
 Port 2 Present 487  
 Port 3 BIST FIS Initiate 499  
 Port 3 Enabled 488  
 Port 3 Present 487  
 Port Arbitration Capability 730  
 Port Arbitration Capability (PAC) 269, 271  
 Port Arbitration Select 731  
 Port Arbitration Select (PAS) 270, 271  
 Port Arbitration Table Entry Size (PATS) 268  
 Port Arbitration Table Offset 730  
 Port Arbitration Table Offset (AT) 269, 271  
 Port Arbitration Tables Status 731  
 Port Arbitration Tables Status (ATS) 270, 272  
 Port Change Detect 611  
 Port Change Interrupt Enable 528, 612  
 Port Configuration (PC) 282  
 Port Connect Change Status 526  
 Port Enable/Disable Change 583, 619  
 Port Enabled/Disabled 584, 620  
 Port I/OxApic Enable 726  
 Port Multiplier FIS Based Switching Enable 530  
 Port Multiplier Attached 530  
 Port Multiplier Port 507, 534, 560  
 Port Number 713, 738  
 Port Number (PN) 273  
 Port Owner 617  
 Port Power 617  
 Port Reset 583, 618  
 Port Test Control 617  
 Port Wake Implemented 597  
 Port Wake Up Capability Mask 597  
 PORT0EN 574  
 PORT1EN 574  
 Ports Implemented Port 0 517, 518, 520  
 Ports Implemented Port 1 517  
 Ports Implemented Port 2 517  
 Ports Implemented Port 3 517, 518, 519, 520  
 PORTSC 616  
 Postable Memory Write Enable 311, 325, 449, 467, 541, 567, 587, 626, 701  
 Power Button Enable 396  
 Power Button Override Status 394  
 Power Button Status 394  
 Power Controller Control 718  
 Power Controller Present 717  
 Power Failure 382  
 Power Fault Detected 719  
 Power Fault Detected Enable 719  
 Power Indicator Control 718  
 Power Indicator Present 657, 711, 717  
 Power Management Capability ID 592  
 Power Management SCI Enable 725  
 Power Management SCI Status 727  
 Power Management SMI Enable 726  
 Power Management SMI Status 727  
 Power On Device 531  
 Power Sequencing 846  
 Power State 318, 482, 553, 594, 655, 724  
 PRO 754, 784  
 PR1 755, 784  
 PR2 755  
 PR3 756  
 PR4 756  
 PRD Interrupt Status 463, 504, 558  
 Prefetchable 473, 590, 649, 707  
 Prefetchable Memory Base 439, 707  
 Prefetchable Memory Base Upper Portion 440, 708  
 Prefetchable Memory Limit 439  
 Prefetchable Memory Limit Upper Portion 440, 708  
 Prefix 759, 787  
 Prefix Opcode 0 759, 787  
 Prefix Opcode 1 759, 787  
 PREOP 759, 787  
 Presence Detect Changed 719  
 Presence Detect Changed Enable 718  
 Presence Detect State 719  
 PRIM\_SIG\_MODE 480, 551  
 Primary Bus Number 436, 704  
 Primary Discard Timer 441, 709



Primary Drive 0 Base Clock 460, 481, 552  
Primary Drive 0 Cycle Time 459, 479, 550  
Primary Drive 0 Synchronous DMA Mode Enable 458, 478, 549  
Primary Drive 1 Base Clock 460, 481, 552  
Primary Drive 1 Cycle Time 459, 479  
Primary Drive 1 IORDY Sample Point 457, 477  
Primary Drive 1 Recovery Time 457, 477  
Primary Drive 1 Synchronous DMA Mode Enable 458, 478  
Primary Master Channel Cable Reporting 460  
Primary Master Trap 498  
Primary Mode Native Capable 469, 543  
Primary Mode Native Enable 469, 543  
Primary Slave Channel Cable Reporting 460  
Primary Slave Trap 498  
Programmable Frame List Flag 606  
Programming Interface 313, 326, 435, 569, 589, 648, 703  
PRQ 366  
PVC 269, 729  
PVCCAP1 660  
PVCCAP2 660  
PVCCTL 660

## R

—R/W  
388  
Rate Select 371  
RC 299  
RCBA 343  
RCCAP 664  
RCTCL 273, 737  
RCTL 720  
Read / Write Control 462, 503, 557  
Read Back Command 354  
Read Completion Boundary Control 715  
Read/Write Mask (RWM) 280, 281, 285, 286  
Read/Write Select 353  
Read/Write Selection Status 355  
Read/Write# (RWI) 284  
Read/Write# (RWIO) 285  
Real Time Clock Index Address 375  
Received 706  
Received Master Abort 312, 434, 438, 450, 468, 542, 568, 588, 627, 647, 702  
Received System Error 438, 706  
Received Target Abort 312, 325, 434, 438, 588, 627, 647, 702, 706  
Received Target Abort SERR# Enable 446  
RECEIVED\_PID\_STS(23-16) 622  
Receiver Error Mask 736  
Receiver Error Status 735  
Receiver Overflow Mask 733  
Receiver Overflow Severity 734  
Receiver Overflow Status 732  
Reclamation 610  
Recovery Time 455, 476, 548  
PVCSTS 661  
PVS 269, 729  
PWRBTN\_EVNT—WO  
388  
PWRBTN\_INT\_EN—R/W  
388  
PWRBTN\_LVL 378  
PWROK Failure 381  
PXC 657  
PxCi 537  
PxCLB 524  
PxCLBU 524  
PxCMD 529  
PxFB 525  
PxFBU 525  
PXID 656  
PxIE 527  
PxIS 526  
PxSACT 537  
PxSCTL 507, 534, 560  
PxSERR 508, 535, 561  
PxSIG 532  
PxSSTS 505, 533, 559  
PxTFD 532  
REDIR\_TBL 367  
Redirection Entry Clear 365  
Reference Clock (RC) 268  
Refresh Cycle Toggle 374  
Register Read Command 361  
Reject Snoop Transactions 730  
Reject Snoop Transactions (RTS) 269, 271  
Remote IRR 367  
Replay Number Rollover Mask 736  
Replay Number Rollover Status 735  
Replay Timer Timeout Mask 736  
Replay Timer Timeout Status 735  
Report Zero for BM\_STS 384  
RES 737  
Reserved 286, 291  
Reserved Page Route (RPR) 302  
Reset CPU 376  
Resource Type Indicator 328, 452, 453, 454, 471, 472, 473, 474, 544, 545, 546, 570, 590  
Response Interrupt 685  
Response Interrupt Control 684  
Response Overrun Interrupt Control 684  
Response Overrun Interrupt Status 685  
Resume Detect 579, 583  
Resume Interrupt Enable 580  
Retrain Link 715  
Revision ID 313, 326, 435, 451, 468, 542, 568, 589, 627, 647, 703  
Revision Identificaiton 742  
RI\_EN 406  
RI\_STS 403  
RID 313, 627



RINTCNT 684  
 RIRB Lower Base Unimplemented Bits 682  
 RIRB Size 685  
 RIRB Size Capability 685  
 RIRB Upper Base Address 683  
 RIRB Write Pointer 683  
 RIRB Write Pointer Reset 683  
 RIRBCTL 684  
 RIRBLBASE 682  
 RIRBSIZE 685  
 RIRBSTS 685  
 RIRBUBASE 683  
 RIRBWP 683  
 Rotate and EOI Codes 360  
 RP1BA 274  
 RP1D 274  
 RP2BA 275  
 RP2D 275  
 RP3BA 276

RP3D 275  
 RP4BA 276  
 RP4D 276  
 RP5BA 278  
 RP5D 277  
 RP6BA 278  
 RP6D 278  
 RPFN—Root Port Function Number for PCI Express Root Ports 283  
 RSTS 720  
 RTC Event Enable 396  
 RTC Status 394  
 RTC\_PWR\_STSRTC Power Status 382  
 RTC\_REGA 371  
 RTC\_REGB 372  
 RTC\_REGC 373  
 RTC\_REGD 373  
 Run/Stop 577, 609  
 RW 635

## S

Sample Base Rate 694  
 Sample Base Rate Divisor 694  
 Sample Base Rate Multiple 694  
 SATA 492  
 SATA 3 Gb/s Capability  
   342, 343  
 SATA Pin (SIP) 288  
 SATA Port 0 Dynamic Clock Gate Enable 306  
 SATA Port 1 Dynamic Clock Gate Enable 306  
 SATA Port 2 Dynamic Clock Gate Enable 306  
 SCI Enable 397  
 SCI IRQ Select 329  
 SCI\_NOW\_CNT—WO  
   388  
 SCLKCG 489  
 SCLKGC 490  
 Scrambler Bypass Mode 739  
 SCRATCHPAD 384  
 Scratchpad 580  
 Scratchpad Bit 366  
 SDBDPL 695  
 SDBDPU 695  
 SDCBL 691  
 SDCTL 688  
 SDFIFOS 693  
 SDFIFOW 692  
 SDFMT 694  
 SDIN State Change Status Flags 673, 759, 787  
 SDIN Wake Enable Flags 673  
 SDLPIB 691  
 SDLVI 692  
 SDSTS 690  
 SEC\_SIG\_MODE 480, 551  
 SECOND\_TO\_STS 419  
 Secondary 498  
 Secondary 66 MHz Capable 706  
 Secondary Bus Number 436, 704

Secondary Bus Reset 441, 709  
 Secondary DEVSEL# Timing Status 706  
 Secondary Discard Timer 441, 709  
 Secondary Discard Timer Testmode 445  
 Secondary Drive 0 Base Clock 481, 552  
 Secondary Drive 0 Cycle Time 479, 550  
 Secondary Drive 0 Synchronous DMA Mode Enable 478, 549  
 Secondary Drive 1 Base Clock 481, 552  
 Secondary Drive 1 Cycle Time 478  
 Secondary Drive 1 IORDY Sample Point 477  
 Secondary Drive 1 Recovery Time 477  
 Secondary Drive 1 Synchronous DMA Mode Enable 478  
 Secondary Fast Back to Back Capable 706  
 Secondary Master Trap 498  
 Secondary Mode Native Capable 469, 543  
 Secondary Mode Native Enable 469, 543  
 Secondary Slave Trap 490, 498  
 Select Power Management 507, 534, 560  
 SEND\_PID\_CNT(15-8) 622  
 Serial ATA Disable (SAD) 305  
 Serial Bus Release Number 572  
 Serial IRQ Enable 331  
 Serial IRQ Frame Size 331  
 Serial IRQ Mode Select 331  
 SERIRQ\_SMI\_STS 410  
 SERR# Enable 311, 325, 432, 442, 449, 467, 541, 567, 587, 626, 646, 701, 710  
 SERR# NMI Source Status 374  
 SERR# Status 647  
 Server Error Reporting Mode (SERM) 301  
 Set Device Bits FIS Interrupt Enable 528  
 Set Device Bits Interrupt 527  
 Short Packet Interrupt Enable 580  
 SID 315, 629, 650  
 SIG\_MODE 460  
 Signaled System Error 312, 325, 434, 450, 468, 542,



588, 627, 702  
Signaled Target Abort 312, 326, 435, 438, 468, 542,  
568, 588, 627, 647, 702, 706  
Signature 532  
Single or Cascade 357  
SIR18 492  
SIR28 493  
Slave Identification Code 359  
Slave Trap 461  
Slave Trap Status 461  
SLAVE\_ADDR 637  
SLCAP 717  
SLCTL 718  
Sleep Enable 397  
Sleep Type 397  
Slot Clock Configuration 716  
Slot Implemented 657, 710  
Slot Power Limit Scale 717  
Slot Power Limit Value 717  
SLP\_S4# Assertion Stretch Enable 382  
SLP\_S4# Minimum Assertion Width 382  
SLP\_SMI\_EN 408  
SLP\_SMI\_STS 411  
SLSTS 719  
SLT 705  
Slumber State Capable 514  
SLV\_CMD 640  
SLV\_STS 639  
SM Bus Disable (SD) 305  
SM Bus Pin (SMIP) 288  
SMB\_CMD 634  
SMB\_SMI\_EN 630  
SMBALERT\_DIS 640  
SMBALERT\_STS 632  
SMBCLK\_CTL 639  
SMBCLK\_CUR\_STS 639  
SMBDATA\_CUR\_STS 639  
SMBus Host Enable 630  
SMBus SMI Status 410  
SMBus TCO Mode 637  
SMBus Wake Status 404  
SMBUS\_PIN\_CTL 639  
SMI at End of Pass-Through Enable 573  
SMI Caused by End of Pass-Through 572  
SMI Caused by Port 60 Read 573  
SMI Caused by Port 60 Write 573  
SMI Caused by Port 64 Read 573  
SMI Caused by Port 64 Write 572  
SMI Caused by USB Interrupt 572  
SMI on Async 600  
SMI on Async Advance 598  
SMI on Async Advance Enable 599  
SMI on Async Enable 600  
SMI on BAR 598  
SMI on BAR Enable 599  
SMI on CF 600  
SMI on CF Enable 601  
SMI on Frame List Rollover 598  
SMI on Frame List Rollover Enable 599  
SMI on HCHalted 600  
SMI on HCHalted Enable 601  
SMI on HCRReset 600  
SMI on HCRReset Enable 601  
SMI on Host System Error 598  
SMI on Host System Error Enable 599  
SMI on OS Ownership Change 598  
SMI on OS Ownership Enable 599  
SMI on PCI Command 598  
SMI on PCI Command Enable 599  
SMI on Periodic 600  
SMI on Periodic Enable 601  
SMI on PMCSR 600  
SMI on PMCSR Enable 600  
SMI on Port 60 Reads Enable 573  
SMI on Port 60 Writes Enable 573  
SMI on Port 64 Reads Enable 573  
SMI on Port 64 Writes Enable 573  
SMI on Port Change Detect 598  
SMI on Port Change Enable 599  
SMI on PortOwner 600  
SMI on PortOwner Enable 600  
SMI on USB Complete 598  
SMI on USB Complete Enable 599  
SMI on USB Error 598  
SMI on USB Error Enable 599  
SMI on USB IRQ Enable 573  
SMI\_LOCK 379  
SMI\_OPTION\_CNT—R/W  
388  
SMLink Slave SMI Status 419  
SMLINK\_CLK\_CTL 638  
SMLINK\_PIN\_CTL 638  
SMLINK0\_CUR\_STS 638  
SMLINK1\_CUR\_STS 638  
SOF Timing Value 581  
Software Debug 576  
Software SMI# Timer Enable 408  
SOP\_MODE\_CAP 451  
SOP\_MODE\_SEL 451  
SP 498  
Space Type 649  
SPDH 442  
Speaker Data Enable 375  
Special Cycle Enable 311, 325, 433, 449, 467, 541,  
567, 587, 626, 646, 701  
Special Fully Nested Mode 359  
Special Mask Mode 361  
Speed Allowed 507, 534, 560  
SPI Read Configuration (SRC) 341  
SPI\_STS 409  
Spin-Up Device 531  
Square Wave Enable 372  
SS\_STATE 414  
SSFC 758, 786  
SSFS 757, 785  
SSTS 706  
SSYNC 679  
START 633  
Start 531  
Start Frame Pulse Width 331



Start/Stop Bus Master 462, 503, 557  
 STATESTS 673  
 Static Bus Master Status Policy Enable 574  
 Status 532  
 STME 492  
 Stream Interrupt Enable 677  
 Stream Interrupt Status 678  
 Stream Number 688  
 Stream Reset 689  
 Stream Run 689  
 Stream Synchronization 679  
 Stripe Control 688  
 STTT1 492  
 STTT2 493  
 STTT3 495  
 Sub Class Code 327, 435, 451, 470, 569, 589, 628,  
 648, 703  
 Subordinate Bus Number 436, 704  
 Subsystem ID 328, 454, 474, 546, 571, 591, 629, 650  
 Subsystem Identifier 446, 722  
 Subsystem Vendor ID 328, 454, 474, 546, 570, 590,  
 629, 650  
 Subsystem Vendor Identifier 446, 722  
 Subtractive Decode Policy 445  
 Supports 64-bit Addressing 513  
 Supports Activity LED 513  
 Supports Aggressive Link Power Management 513  
 Supports Cold Presence Detect 513  
 Supports Command List Override (SCLO) 514  
 Supports Command Queue Acceleration 513  
 Supports Interlock Switch 513  
 Supports Non-Zero DMA Offsets 514  
 Supports Port Multiplier 514  
 Supports Port Multiplier FIS Based Switching 514  
 Supports Port Selector Acceleration 514  
 Supports Staggered Spin-up 513  
 Suspend 583, 618  
 SVCAP 722  
 SVID 315, 629, 650, 722  
 SW\_TCO\_SMI 418  
 SWGPE\_CTRL 412  
 SWGPE\_EN 406  
 SWGPE\_STS 404  
 SWSMI\_RATE\_SEL 381  
 SWSMI\_TMR\_STS 411  
 System Error on Correctable Error Enable 720  
 System Error on Fatal Error Enable 720  
 System Error on Non-Fatal Error Enable 720  
 System Reset 376  
 System Reset Status 380

## T

Target Component ID 738  
 Target Component ID (TCID) 273, 274, 275, 276, 277,  
 278  
 Target Port Number 738  
 Target Port Number (PN) 273, 274, 275, 276, 277, 278  
 Task File Error Enable 527  
 Task File Error Status 526  
 TCO 287  
 TCO Data In Value 417  
 TCO Data Out Value 417  
 TCO IRQ Select (IS) 287  
 TCO Timer Halt 420  
 TCO Timer Initial Value 422  
 TCO Timer Value 416  
 TCO\_EN 407  
 TCO\_INT\_STS 418  
 TCO\_LOCK 420  
 TCO\_MESSAGE(n) 421  
 TCO\_STS 410  
 TCOSCI\_EN 406  
 TCOSCI\_STS 404  
 TCSEL 652  
 TCTL 287  
 Thermal Interrupt Status 404  
 THRM\_DTY 399  
 THRM\_EN 406  
 THRM#\_POL 412  
 Throttle Status 398  
 THTL\_DTY 399  
 THTL\_EN 399  
 TIMEOUT 418  
 Timeout/CRC Interrupt Enable 580  
 Timer 0 Interrupt Active 743  
 Timer 1 Interrupt Active 743  
 Timer 2 Interrupt Active 743  
 Timer Compare Value 746  
 Timer Counter 2 Enable 375  
 Timer Counter 2 OUT Status 374  
 Timer Interrupt Rout Capability 744  
 Timer Interrupt Type 745  
 Timer n 32-bit Mode 745  
 Timer n Interrupt Enable 745  
 Timer n Size 745  
 Timer n Type 745  
 Timer n Value Set 745  
 Timer Overflow Interrupt Enable 396  
 Timer Overflow Status 395  
 Timer Value 398  
 TIMn\_COMP 746  
 TOKEN\_PID\_CNT(7-0) 622  
 Top Swap (TS) 303  
 Top Swap Status (TSS) 341  
 Traffic Priority 688  
 Training 732  
 Training Error Mask 733  
 Training Error Severity 734  
 Transaction Class / Virtual Channel Map 731  
 Transaction Class / Virtual Channel Map (TVM) 270,  
 271  
 Transactions Pending 659, 713  
 Trap and SMI# Enable (TRSE) 285  
 Trapped I/O Address (TIOA) 284



Trapped I/O Data (TIOD) 285  
TRCR 284  
Trigger Mode 367

TWDR 285  
Type 473, 590

## U

UEM 733  
UES 732  
UEV 734  
UHCI #0 Pin (UOP) 289  
UHCI #1 Disable (U1D) 305  
UHCI #1 Pin (U1P) 289  
UHCI #2 Disable (U2D) 305  
UHCI #2 Pin (U2P) 289  
UHCI #3 Disable (U3D) 305  
UHCI #4 Disable (U4D) 305  
UHCI v/s EHCI 213  
UHCI\_BREAK\_EN 386  
ULBA 274, 739  
ULD 273, 738  
Unexpected Completion Mask 733  
Unexpected Completion Severity 734  
Unexpected Completion Status 732  
Unimplemented Asynchronous Park Mode Bits 608  
Unique Clock Exit Latency 725  
Unknown FIS Interrupt 527  
Unknown FIS Interrupt Enable 528  
Unlocked 383  
Unsupported 733, 734  
Unsupported Request Detected 659, 713  
Unsupported Request Error Status 732  
Unsupported Request Reporting Enable 658, 712  
Update Cycle Inhibit 372  
Update In Progress 371  
Update-Ended Flag 373

Update-Ended Interrupt Enable 372  
Upper 128 Byte Enable (UE) 299  
Upper 128 Byte Lock (UL) 299  
Upper Address(63-44) 614  
Upper Base Address 649  
Upstream Read Latency Threshold 445  
USB EHCI Dynamic Clock Gate Enable 306  
USB EHCI Static Clock Gate Enable 306  
USB Error Interrupt 579, 611  
USB Error Interrupt Enable 612  
USB Interrupt 579, 611  
USB Interrupt Enable 612  
USB Release Number 595  
USB UHCI Dynamic Clock Gate Enable 306  
USB\_ADDRESS\_CNF 623  
USB\_ENDPOINT\_CNF 623  
USB\_RES 574  
USB1\_EN 406  
USB1\_STS 404  
USB2 608, 610, 612  
USB2\_EN 406  
USB2\_STS 404  
USB3\_EN 405  
USB3\_STS 402  
USB4\_EN 405  
USB4\_STS 402  
USBPID 622  
Use SATA Class Code 486  
User Definable Features 450, 468, 542, 568, 588, 627

## V

VOCAP 269, 730  
VOCTL 270, 731  
VOSTS 270, 731  
V1CTL 271  
V1STS 272  
Valid RAM and Time Bit 373  
VC Arbitration Capability (AC) 268  
VC Arbitration Select 729  
VC Arbitration Select (AS) 269  
VC Arbitration Table Offset 729  
VC Arbitration Table Offset (ATO) 268  
VC Arbitration Table Status 729  
VC Arbitration Table Status (VAS) 269  
VC Negotiation Pending 731  
VC Negotiation Pending (NP) 270, 272  
VCOCAP 661  
VCOCTL 661  
VCOSTS 662  
VCAP1 268  
VCAP2 268, 729  
VCCAP 659

VCH 268, 729  
VCiCAP 662  
VCiCTL 663  
VCiSTS 663  
Vector 368  
Vendor ID 310, 324, 432, 448, 466, 540, 566, 586,  
625, 645, 700, 790  
Vendor ID Capability 742  
VER 366  
Version 317, 366, 482, 552, 593, 654, 723  
VGA 16-Bit Decode 441, 709  
VGA Enable 442, 710  
VGA Palette Snoop 311, 325, 432, 449, 467, 541, 567,  
587, 626, 646, 701  
VID 310, 645  
Virtual Channel Enable 731  
Virtual Channel Enable (EN) 270, 271  
Virtual Channel Identifier 731  
Virtual Channel Identifier (ID) 270, 271  
VMAJ 670  
VMIN 670





VS 518

VSCC 762

## W

Wait Cycle Control 311, 325, 432, 449, 467, 541, 567,  
587, 626, 646, 701  
Wake on Connect Enable 616  
Wake on Disconnect Enable 616  
Wake on Overcurrent Enable 616  
Wake Status 393  
WAKEEN 673

WALCLK 679  
Wall Clock Counter 679  
Write Granularity (WG) 762  
Write Status Required (WSR) 762  
WRITE\_READ#\_CNT 622  
WRT\_RDONLY 601, 602

## X

XCAP 710



## X-ON Electronics

Largest Supplier of Electrical and Electronic Components

*Click to view similar products for [I/O Controller Interface IC](#) category:*

*Click to view products by [Intel](#) manufacturer:*

Other Similar products are found below :

[CYDMX128B16-65BVXI](#) [DSL5110 SR1TY](#) [EC-GAV](#) [SCH5327B-NS](#) [SEC1210/PV-URT](#) [LPC47M287-NW](#) [SEC1210I-CN-02](#) [CP2108-B02-GM](#) [LPC47M107S-MS](#) [LPC47M102S-MS](#) [70M-OAC15A](#) [NCT6776D](#) [Z85C3010PSG](#) [Z84C4310AEG](#) [IS31IO7326-QFLS4-EB](#)  
[Z16C3010VEG](#) [JHL2210 S LL38](#) [MAX5940CESA+](#) [84115502](#) [SLO24IRA](#) [84145010](#) [20LPCV2415](#) [84130108](#) [SM-OAC5AR](#) [DS2483Q+T](#)  
[SEC1210I-CN-02-TR](#) [LPC47B277-MS](#) [JHL8010R S LMND](#) [KTI225V S LN9C](#) [JHL8040R S LMN6](#) [CP2109-A01-GMR](#) [MCP2140A-ISS](#)  
[MCP2155-IP](#) [MCP2140A-ISO](#) [SNAP-AIMA-8](#) [IAC5A](#) [IDC5Q](#) [Z84C1510AEG](#) [SCH5017-NW](#) [ODC5](#) [TDA8026ET/C2,518](#) [IAC5](#) [CP2112-F02-GMR](#) [CP2109-A01-GM](#) [LPC47M192-NW](#) [FDC37B787-NS](#) [FDC37C669-MS](#) [MCP2140-ISO](#) [73S8009CN-32IM/F](#) [MAX14824GTG+](#)