

**GMKDS 3/ 2-7,62**

Order No.: 1731721

<http://eshop.phoenixcontact.net/phoenix/treeViewClick.do?UID=1731721>

PC terminal block, Nominal current: 24 A, Nom. voltage: 500 V,  
Pitch: 7.62 mm, Number of positions: 2, Type of connection: Screw  
connection, Assembly: Soldering, Conductor/PCB connection  
direction: 0 °, Color: green, The article can be aligned to create  
different nos. of positions!

**Commercial data**

EAN	4017918026400
Pack	50 pcs.
Customs tariff	85369010
Weight/Piece	0.004836 KG
Catalog page information	Page 91 (CC-2009)

**Product notes**

WEEE/RoHS-compliant since:  
01/01/2003



[http://  
www.download.phoenixcontact.com](http://www.download.phoenixcontact.com)  
Please note that the data given  
here has been taken from the  
online catalog. For comprehensive  
information and data, please refer  
to the user documentation. The  
General Terms and Conditions of  
Use apply to Internet downloads.

**Technical data****Dimensions / positions**

Length	11.2 mm
Pitch	7.62 mm
Dimension a	7.62 mm

Number of positions	2
Pin dimensions	0,9 x 0,9 mm
Hole diameter	1.3 mm
Screw thread	M3
Tightening torque, min	0.5 Nm
Tightening torque max	0.6 Nm

**Technical data**

Insulating material group	I
Rated surge voltage (III/3)	6 kV
Rated surge voltage (III/2)	6 kV
Rated surge voltage (II/2)	6 kV
Rated voltage (III/2)	630 V
Rated voltage (II/2)	1000 V
Connection in acc. with standard	EN-VDE
Nominal current $I_N$	24 A
Nominal voltage $U_N$	500 V
Nominal cross section	2.5 mm <sup>2</sup>
Maximum load current	30 A (with 4 mm <sup>2</sup> conductor cross section)
Insulating material	PA
Inflammability class acc. to UL 94	V0
Internal cylindrical gage	A3
Stripping length	8 mm

**Connection data**

Conductor cross section solid min.	0.2 mm <sup>2</sup>
Conductor cross section solid max.	4 mm <sup>2</sup>
Conductor cross section stranded min.	0.2 mm <sup>2</sup>
Conductor cross section stranded max.	2.5 mm <sup>2</sup>
Conductor cross section stranded, with ferrule without plastic sleeve min.	0.25 mm <sup>2</sup>
Conductor cross section stranded, with ferrule without plastic sleeve max.	2.5 mm <sup>2</sup>
Conductor cross section stranded, with ferrule with plastic sleeve min.	0.25 mm <sup>2</sup>
Conductor cross section stranded, with ferrule with plastic sleeve max.	2.5 mm <sup>2</sup>
Conductor cross section AWG/kcmil min.	24

Conductor cross section AWG/kcmil max	12
2 conductors with same cross section, solid min.	0.2 mm <sup>2</sup>
2 conductors with same cross section, solid max.	1.5 mm <sup>2</sup>
2 conductors with same cross section, stranded min.	0.2 mm <sup>2</sup>
2 conductors with same cross section, stranded max.	1.5 mm <sup>2</sup>
2 conductors with same cross section, stranded, ferrules without plastic sleeve, min.	0.25 mm <sup>2</sup>
2 conductors with same cross section, stranded, ferrules without plastic sleeve, max.	0.75 mm <sup>2</sup>
2 conductors with same cross section, stranded, TWIN ferrules with plastic sleeve, min.	0.5 mm <sup>2</sup>
2 conductors with same cross section, stranded, TWIN ferrules with plastic sleeve, max.	1.5 mm <sup>2</sup>

#### Certificates / Approvals



Certification CCA, CSA, CUL, GL, GOST, SEV, UL

#### CSA

Nominal voltage U <sub>N</sub>	300 V
Nominal current I <sub>N</sub>	10 A
AWG/kcmil	28-12

#### CUL

Nominal voltage U <sub>N</sub>	300 V
Nominal current I <sub>N</sub>	10 A
AWG/kcmil	30-12

#### UL

Nominal voltage U <sub>N</sub>	300 V
Nominal current I <sub>N</sub>	10 A
AWG/kcmil	30-12

### Accessories

Item	Designation	Description
------	-------------	-------------

### Assembly

1711408	EA-MKDS	Single cover, to cover individual terminal positions, snap-fitting, color: orange, transparent
---------	---------	--

### Marking

0804552	SK 7,62/5:FORTL.ZAHLEN	Marker card, printed horizontally, self-adhesive, 10-section marker strip, 10 identical decades marked 1-10, 11-20 etc. up to 91-100, sufficient for 100 terminal blocks
---------	------------------------	--

### Tools

1205053	SZS 0,6X3,5	Screwdriver, bladed, matches all screw terminal blocks up to 4.0 mm <sup>2</sup> connection cross section, blade: 0.6 x 3.5 mm, without VDE approval
---------	-------------	--

### Diagrams/Drawings

Drilling plan/solder pad geometry

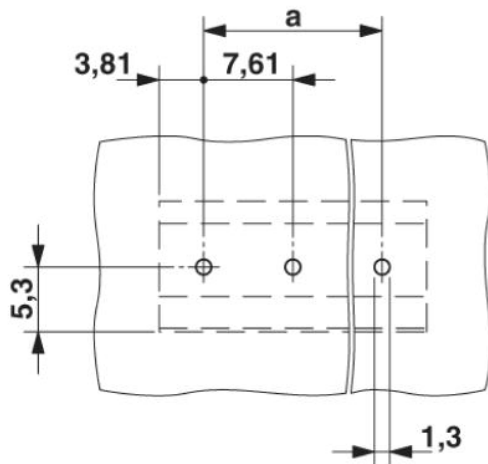

Dimensioned drawing

---

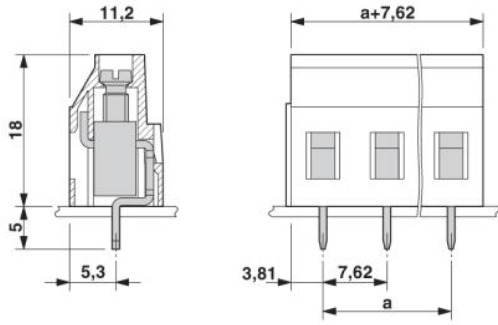

**Address**

PHOENIX CONTACT GmbH & Co. KG  
Flachsmarktstr. 8  
32825 Blomberg, Germany  
Phone +49 5235 3 00  
Fax +49 5235 3 41200  
<http://www.phoenixcontact.com>



© 2010 Phoenix Contact  
Technical modifications reserved;

## X-ON Electronics

Largest Supplier of Electrical and Electronic Components

*Click to view similar products for [Pluggable Terminal Blocks](#) category:*

*Click to view products by [Phoenix Contact](#) manufacturer:*

Other Similar products are found below :

[57.404.7553](#) [57.504.0053.7](#) [57.510.0053](#) [57.910.6153](#) [01.112.1453](#) [CTB932VE/6](#) [MC 1.5/ 6-ST-3.5 GY AU](#) [ET02015000J0G](#) [734-104](#) [734-302](#) [734-304](#) [8-141-P](#) [FKCT 2.5/ 3-ST KMGY](#) [860505](#) [860508](#) [860516](#) [860810](#) [861908](#) [GBPACX-12](#) [93.731.4953.0](#) [PV05-5,08-K](#) [PVP02-5,00](#) [PVP04-3,50](#) [PVS02-5,00](#) [1-1986160-3](#) [H-10](#) [1546228-5](#) [ELFH09150](#) [ELFH16150](#) [ELFP03110](#) [ELFT06250](#) [ELFT07250](#) [ELVF09400](#) [ELVP03100](#) [ELXH03100](#) [ELXH071G0E](#) [ELXP041G0](#) [ELXT046G0](#) [1700101](#) [1700410](#) [1700425](#) [1703176](#) [1703243](#) [1705229](#) [1710175](#) [1714537](#) [1717806](#) [1719600](#) [1728941](#) [1729386](#)