

Calmark offers the Series 107 Aluminum Inserter-Extractor for safe and easy insertion and extraction of printed circuit boards in the most severe applications. This product series offer a wide range of inserter-extractor with varying features from mechanical advantage ratios, color, board thickness, etc. If you don't see one here that meets your requirements, please contact our Applications Engineers with your specification.

FEATURES

- "Ultra strong" lever action design overcomes insertion and extraction forces of highest possible limits
- Widths from 7.37 (.290) to 7.92 (.312) for printed circuit boards ranging from 1.6 (.063) to 3.2 (.125) thick
- Actuates from a simple "U" channel form
- Mounting detail on card retrofits other industry standards
- Available in black anodize or clear chemical film
- Generous area for identification markings
- Strong and Ultra-strong lever action overcome high insertion and extraction forces
- 107-73 and 107-75 offers a positive locking feature

MATERIALS/FINISH

EXTRACTOR

Aluminum alloy 6061-T6. Black anodize per Mil-A-8625, Type II Cl. 2. or Clear chemical film per Mil-5541 Cl 3 for a conductive finish. Other anodize colors or a gold chemical film also available. Please contact an Application Engineer with your requirements.

ROLL PIN

Stainless steel, 2.38 (.094) x 6.35 (.250) [except all Series 107-35 use 7.95 (.313) long]. Roll pins are furnished with each inserter-extractor. [Series 107-73 and 107-75, two roll pins]



Series 107-50 - Inserter/Extractor (Aluminum)

Series	Feature	Board Thickness	Standard Color	Mechanical Advantage	Figures
107-35	I E	1.6 (.063)	black	5.5:1	1/A
C107-35	I E	1.6 (.063)	clear	5.5:1	1/A
107-35-3	I E	2.4 (.093)	black	5.5:1	1/A
C107-35-3	I E	2.4 (.093)	clear	5.5:1	1/A
107-35-4	I E	3.2 (.125)	black	5.5:1	1/A
C107-35-4	I E	3.2 (.125)	clear	5.5:1	1/A
107-50	I E	1.6 (.063)	black	4.5:1	2/B
C107-50	I E	1.6 (.063)	clear	4.5:1	2/B
107-50-3	I E	2.4 (.093)	black	4.5:1	2/B
C107-50-3	I E	2.4 (.093)	clear	4.5:1	2/B
107-50-4	I E	3.2 (.125)	black	4.5:1	2/B
C107-50-4	I E	3.2 (.125)	clear	4.5:1	2/B
107-51	I E	1.6 (.063)	black	3.3:1	3/B
C107-51	I E	1.6 (.063)	clear	3.3:1	3/B
107-51-3	I E	2.4 (.093)	black	3.3:1	3/B
C107-51-3	I E	2.4 (.093)	clear	3.3:1	3/B
107-51-4	I E	3.2 (.125)	black	3.3:1	3/B
C107-51-4	I E	3.2 (.125)	clear	3.3:1	3/B
107-55	I E	1.6 (.063)	black	8:1	4/B
C107-55	I E	1.6 (.063)	clear	8:1	4/B
107-55-3	I E	2.4 (.093)	black	8:1	4/B
C107-55-3	I E	2.4 (.093)	clear	8:1	4/B
107-55-4	I E	3.2 (.125)	black	8:1	4/B
C107-55-4	I E	3.2 (.125)	clear	8:1	4/B
107-73	I E L	1.6 (.063)	black	4.2:1	5/C
C107-73	I E L	1.6 (.063)	clear	4.2:1	5/C
107-73-3	I E L	2.4 (.093)	black	4.2:1	5/C
C107-73-3	I E L	2.4 (.093)	clear	4.2:1	5/C
107-73-4	I E L	3.2 (.125)	black	4.2:1	5/C
C107-73-4	I E L	3.2 (.125)	clear	4.2:1	5/C
107-75	I E L	1.6 (.063)	black	7:1	6/C
C107-75	I E L	1.6 (.063)	clear	7:1	6/C
107-75-3	I E L	2.4 (.093)	black	7:1	6/C
C107-75-3	I E L	2.4 (.093)	clear	7:1	6/C
107-75-4	I E L	3.2 (.125)	black	7:1	6/C
C107-75-4	I E L	3.2 (.125)	clear	7:1	6/C

Feature: I = Inserter E = Extractor L = Latching
For Pre-start pin feature, add "P" prefix to part number

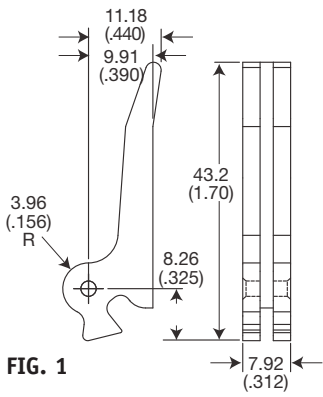

FIG. 1

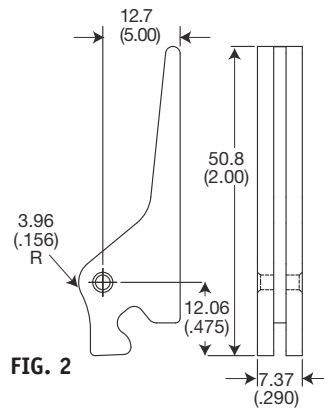

FIG. 2

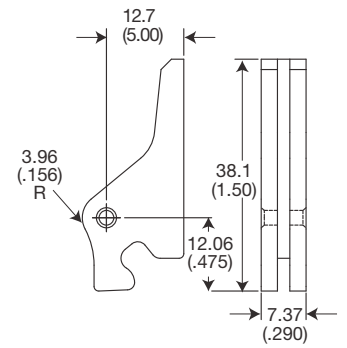

FIG. 3

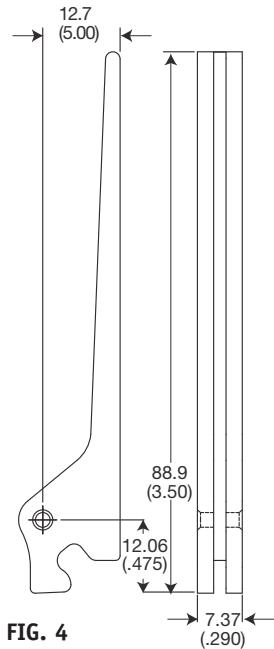

FIG. 4

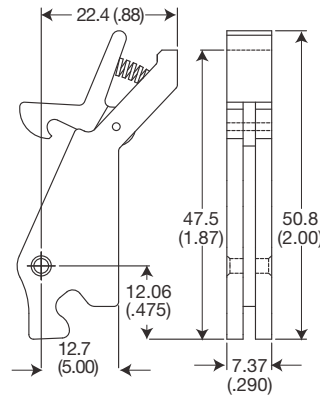

FIG. 5

Units: mm (in)
 Unless specified otherwise,
 .xx = ± .25, x = ± .5
 (.xxx = ± .010, .xx = ± .02)

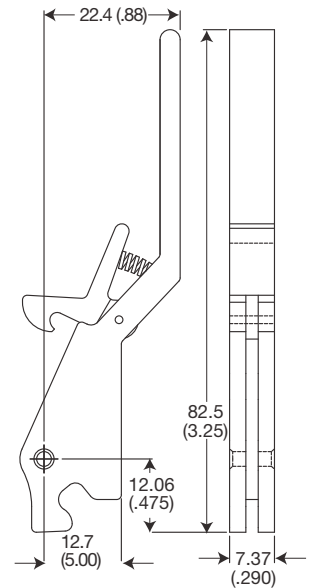
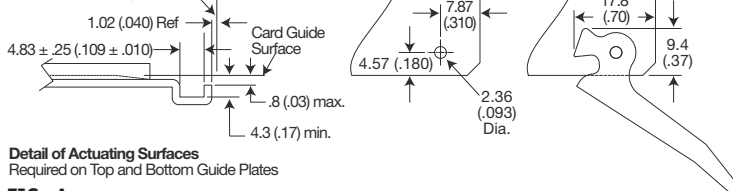

FIG. 6

Provides insertion and extraction travel of 7.6 (.30) min.

Nominal position of card edge when seated in connector. The Inserter-Extractor will allow .76 (.03) overtravel for tolerance take-up.



Detail of Actuating Surfaces
 Required on Top and Bottom Guide Plates

FIG. A

APPLICATION DATA

Two inserter or inserter-extractors are recommended per printed circuit board taller than 127 (5) in height.

Units: mm (in)
 Unless specified otherwise,
 .xx = ± .25, x = ± .5
 (.xxx = ± .010, .xx = ± .02)

Provides insertion and extraction travel of 8.9 (.35) min.

Nominal position of card edge when seated in connector. The Inserter-Extractor will allow 1.3 (.05) overtravel for tolerance take-up.

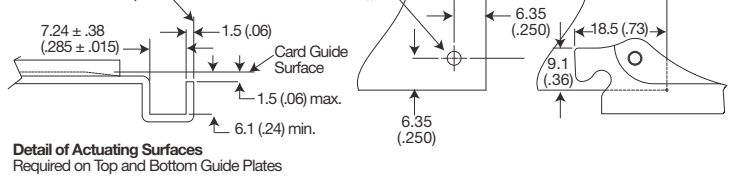

Detail of Actuating Surfaces
 Required on Top and Bottom Guide Plates

FIG. B

Provides insertion and extraction travel of 8.9 (.35) min.

Nominal position of card edge when seated in connector. The Inserter-Extractor will allow 1.3 (.05) overtravel for tolerance take-up.

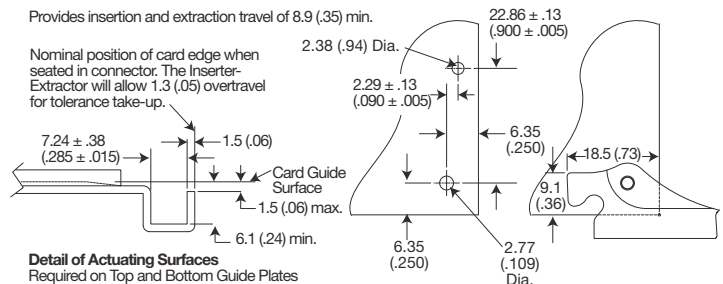

Detail of Actuating Surfaces
 Required on Top and Bottom Guide Plates

FIG. C

X-ON Electronics

Largest Supplier of Electrical and Electronic Components

Click to view similar products for [Calmark](#) manufacturer:

Other Similar products are found below :

[15B-6-3](#) [24BX-2-12-7-L](#) [24BX-2-12-7-R](#) [40-5-10](#) [CCKP01-ZD-2](#) [35-1B-2-6-3](#) [48-5S-10-B-L](#) [A260-4.80T2KSM](#) [35-7B-2-10-3](#) [41-8-B-LF-LN-S-L](#) [107-51](#) [41-5-10-CC-LF](#) [L260-4.80-1](#) [CCKJ01-AD-2](#) [44-5-10-LF-L](#) [CCKJ32-CD-1-CC](#) [CCKJ32-ZA-1-CC](#) [CCKJ32-ZC-1-CC](#) [24BX-2-11-3-L](#) [CCKP01-ZC-2](#) [107-55](#) [A280-4.80ET4](#) [24BX-2-12-3-L](#) [C107-73](#) [24SX-2-10-3R](#) [S71-4-L-BL](#) [CCKP01-ZA-2](#) [PS71-3-L](#) [LE260-330-2P](#) [C107-50](#) [CCKP01-ZA-3](#) [CCKP32-AC-3](#) [CCKJ32-AC-1-CC](#) [C107-55](#) [L260-4.80-2](#) [CCKP32-ZA-2](#) [35-1B-2-5-3](#) [24BX-2-10-9-L](#) [40-8-LF](#) [94-4-16](#) [35-7B-2-8-3](#) [40-7-LF-LN-S](#) [24BX-2-18-1-L](#) [17B-18-3](#) [24BX-2-10-9-R](#) [24BX-2-18-1-R](#) [35-1B-2-8-3](#) [42-5-10-LF](#) [35-1B-2-7-3](#) [P107-50-3](#)