

NAIS

**HIGHLY RELIABLE MINIATURE
DIP RELAYS**

DR-RELAYS

UL File No.: E43149 CSA File No.: LR26550

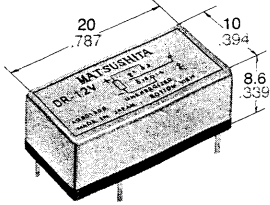

mm inch

- High breakdown voltage – Between open contacts: 750 Vrms
Between contacts and coil: 1500 Vrms
- Surge voltage withstand: 1500 V (Based on part 68, FCC standard)
- 1 coil and 2 coil latching types available
- High sensitivity
- High contact pressure
- Miniature size and low profile —standing only 8.6 mm (.339 inches) including stand-offs on headers
- High speed —Operate time: Approx. 1 msec.

SPECIFICATIONS

Contacts	
Arrangement	1 Form C
Initial contact resistance, max. (By voltage drop 6 V DC 1 A)	60 mΩ
Initial contact pressure	Approx. 9 g .32 oz
Electrostatic capacitance	
Contact-Contact	3 pF
N.O. contact-Coil	4 pF
N.C. contact-Coil	5 pF
UL-Rating (resistive)	
Switching power	33 VA, 20 W
Switching voltage	110 V AC, 30 V DC
Switching current	AC 0.3 A, DC 1 A
Contact material	Gold cobalt
Expected life (min. operations)	
Mechanical (at 50 cps.)	10 ⁹
Electrical	
1 A 20 V DC resistive	10 ⁶
0.3 A 110 V AC resistive	10 ⁶
0.2 A 24 V DC resistive	10 ⁷

Contact bounce	
Single side stable	Approx. 0.5 msec.
1 coil latching	Approx. 0.3 msec.
2 coil latching	Approx. 0.3 msec.
Characteristics	
Max. operating speed	60 cpm at nominal load 300 cps. at no load
Operate time	Approx. 1 msec.
Release time	Approx. 0.5 msec.
Initial breakdown voltage	
Between open contacts	750 Vrms
Between live parts and ground	1,000 Vrms
Between coil and contact	1,500 Vrms
Initial insulation resistance	Min. 1,000 MΩ at 500 V DC
Max. continuous power	0.5 W
Temperature rise	20 deg. (at 120 mW application) 47 deg. (at 500 mW application)
Ambient temperature	-50°C to +85°C -58°F to +185°F
Shock resistance	More than 100 G
Vibration resistance	20 G, 10 to 55 Hz at double amplitude of 3.3 mm
Unit weight	4 g .14 oz

TYPES AND COIL DATA at 20°C 68°F

Single side stable	Pick-up voltage, V DC (max.)	Drop-out voltage, V DC (min.)	Maximum allowable voltage, V DC	Coil resistance, Ω (±10%)	Nominal operating power, mW
DR-3V	2.4	0.3	6.8	94	96
DR-5V	4.0	0.3	10.9	320	78
DR-6V	4.8	0.6	12.8	330	109
DR-12V	9.6	1.2	26.4	1,400	103
DR-24V	17.0	2.4	42.4	3,600	160
DR-48V	33.6	4.8	74.1	11,000	209

1 coil latching	Pick-up voltage, V DC (max.)	Maximum allowable voltage, V DC	Coil resistance, Ω (±10%)	Nominal operating power, mW
DR-L-3V	2.4	8.9	160	56
DR-L-5V	4.0	14.5	420	59
DR-L-6V	4.8	17.4	610	59
DR-L-12V	9.6	33.9	2,300	63
DR-L-24V	17.0	53.8	5,800	99
DR-L-48V	33.6	102.7	21,100	110

2 coil latching	Pick-up voltage, V DC (max.)	Maximum allowable voltage, V DC	Coil resistance, Ω (±10%) Coil I & Coil II	Nominal operating power, mW
DR-L2-3V	2.4	6.3	80	112
DR-L2-5V	4.0	10.6	225	111
DR-L2-6V	4.8	12.0	290	124
DR-L2-12V	9.6	24.6	1,210	119
DR-L2-24V	18.0	43.8	3,840	150
DR-L2-48V	33.6	63.0	7,950	290

ORDERING INFORMATION

Ex. DR — L2 — 24V

Operating function	Coil voltage
Nil: Single side stable	3, 5, 6, 12,
L: 1 coil latching	24, 48 V
L2: 2 coil latching	

- (Notes) 1. For UL/CSA recognized types, add suffix UL/CSA.
2. Standard packing: Carton; 50 pcs.
Case; 500 pcs.

TYPICAL APPLICATIONS

Telecommunications equipment, alarm devices, machine tools, NC machines, automatic warehouse control, conveyors, air-conditioners, pressing machines, textile machinery, elevators, control panels, pin-board programmers, parking meters, industrial robots, detectors, annunciators, optical instruments, business machine, time recorders, cash registers, copiers, vending machines, medical equipment.

DIMENSIONS

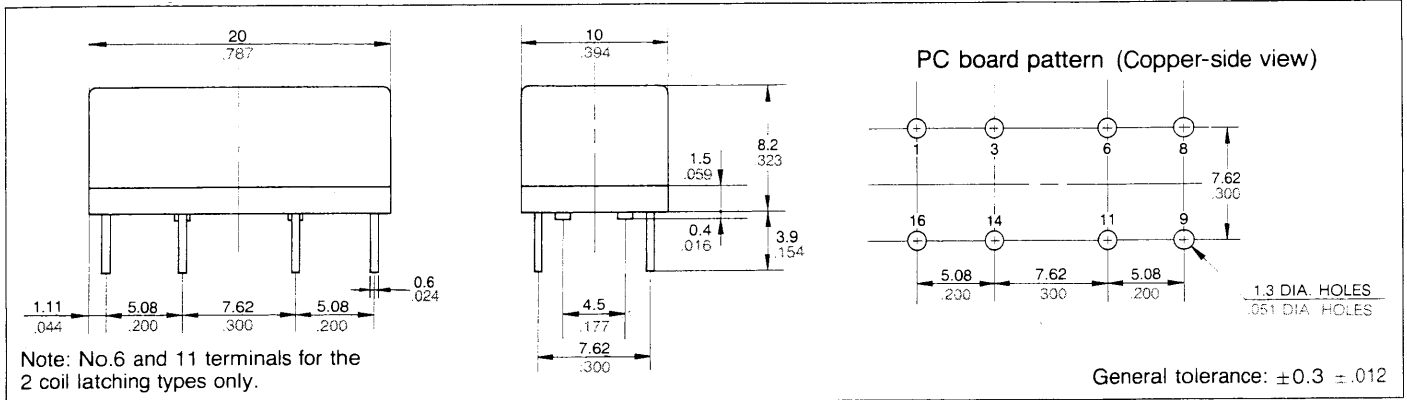

Note: No.6 and 11 terminals for the 2 coil latching types only.

SCHEMATIC (Bottom view)

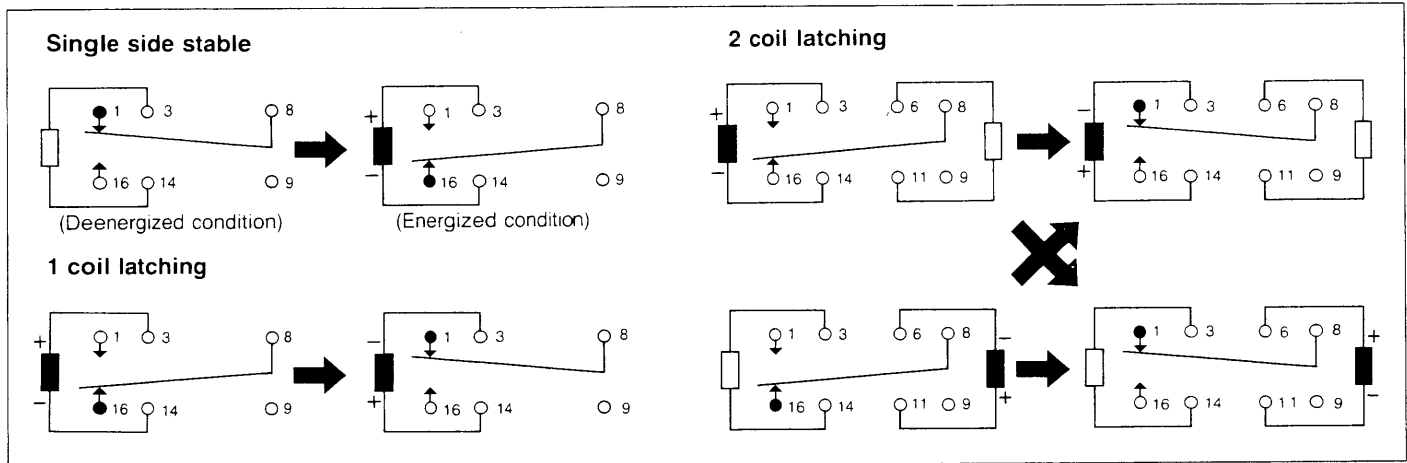

DR-C POWER SAVING RELAYS

Rated voltage	$U_{pick\ up\ at\ +20^{\circ}C}$	$U_{permiss\ at\ 40^{\circ}C}$	$U_{dropout}$
5*	4.5 (25°C) $\frac{du}{dt} > \frac{8V}{ms}$	7	2 (25°C) $\frac{du}{dt} > \frac{8V}{ms}$
12*	9 (25°C)	26	7.5 (25°C)

Advantages: No coil heating or thermo voltage, resulting in increased reliability of the relay and neighbouring components. Defined pick-up and drop-out values with negative temperature co-efficient of approximately 0.028 V/°C. Thus, for example, the DR-C-12 V picks up at 7.6 V at 75°C and at 9.8 V at -5°C.

By parallel switching a capacitor it is possible to achieve drop-out relays of approximately 0.15 s/μF with the DR-C-12 V.

Attention! With the DR-C relay, as with the DR-L- and DR-L2- relays the position of the changeover contact is unknown. After the first control signal, the contact position is as shown in the diagram.

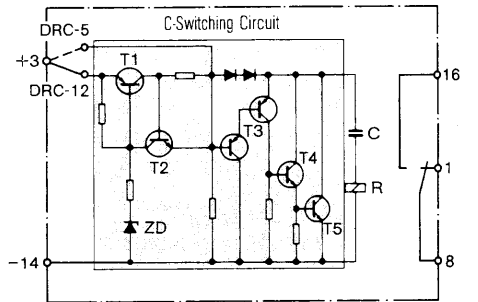

* DR-C relays have an integrated C switching circuit. Thus, after the initial pick-up time of 0.5 ms, no significant current flows through the coil. Interruption of the coil voltage (eg on switch-off) allows the capacitor to discharge via the coil and trigger circuit, resetting the relay to its deenergised condition.

DATA

Operate and release time (Single side stable)

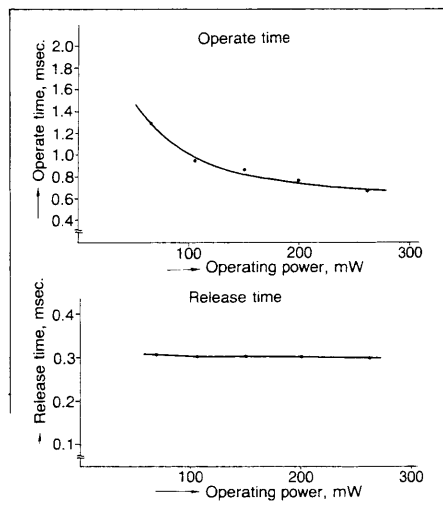

Coil temperature rise (Single side stable)

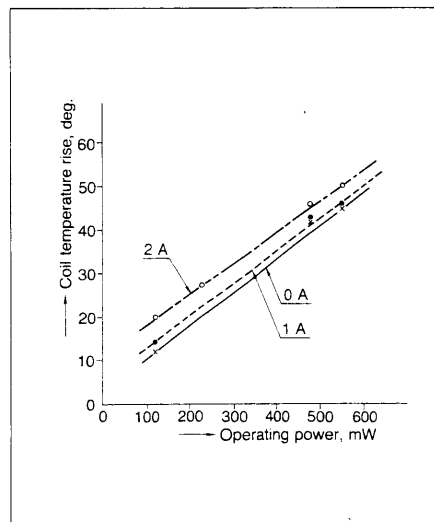

Load limit curves

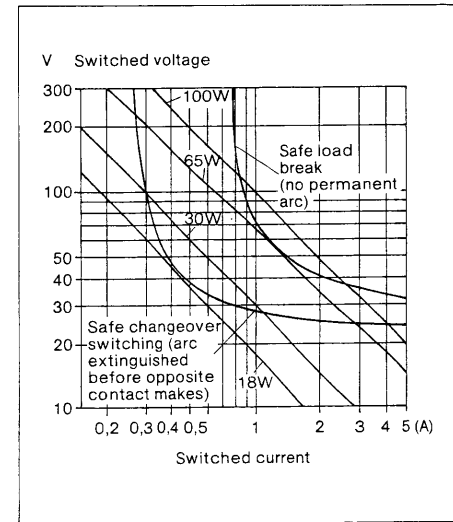

DR

Pick-up/drop-out voltage vs. temperature
(Single side stable)

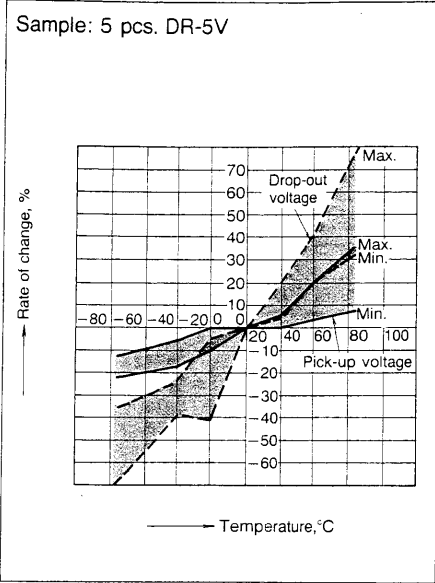

Pick-up/drop-out voltage vs. temperature
(1-coil latching)

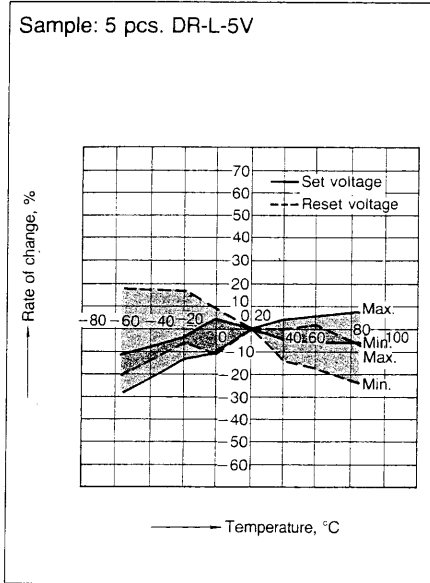

Mechanical life
Change of pick-up and drop-out V

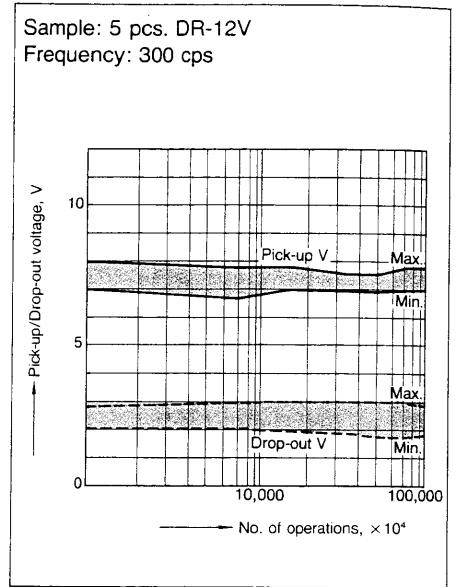

Mechanical life
Change of contact resistance

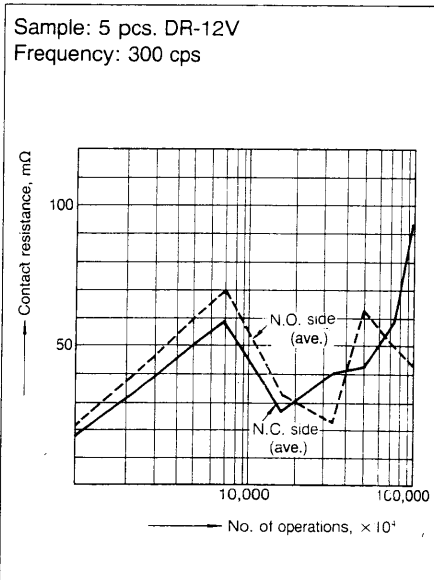

Contact reliability test

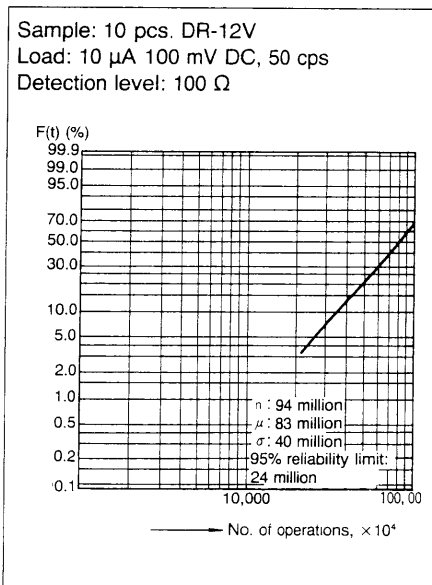

Electrical life

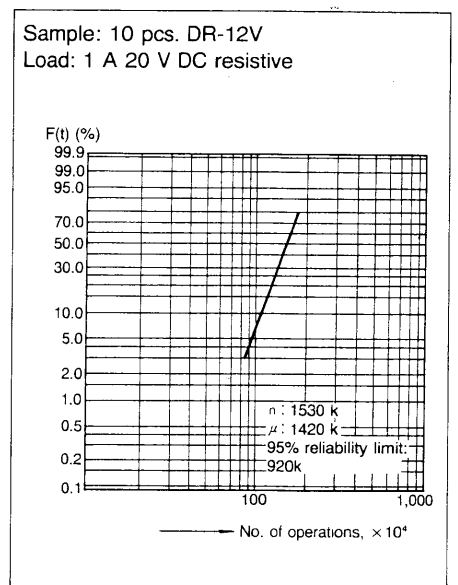

Electrical life test

Change of pick-up and drop-out voltage

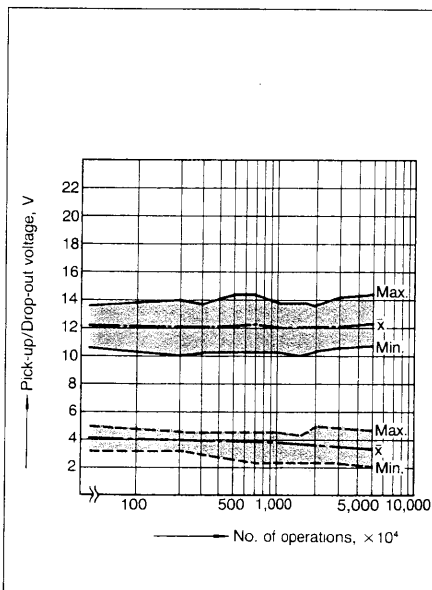

Change of contact resistance

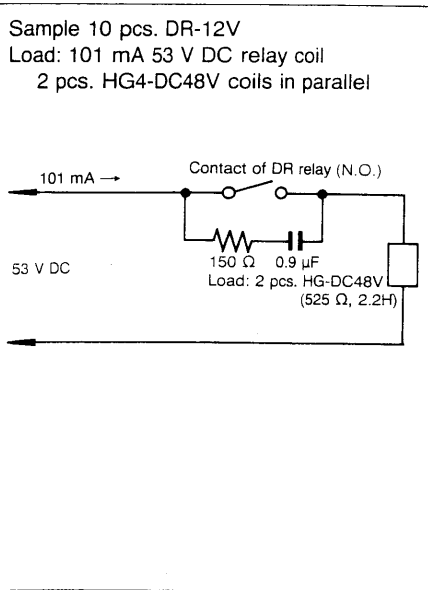
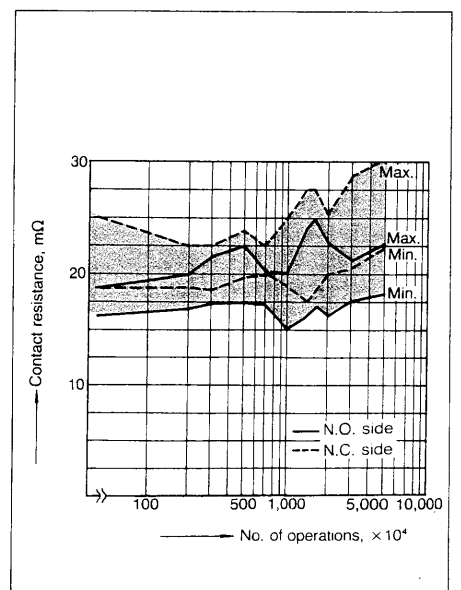

X-ON Electronics

Largest Supplier of Electrical and Electronic Components

Click to view similar products for [General Purpose Relays](#) category:

Click to view products by [Panasonic](#) manufacturer:

Other Similar products are found below :

[APF30318](#) [JVN1AF-4.5V-F](#) [PCN-105D3MHZ](#) [5JO-10000S-SIL](#) [5JO-1000CD-SIL](#) [5JO-400CD-SIL](#) [LY2S-AC220/240](#) [LYQ20DC12](#)
[6031007G](#) [6131406HQ](#) [6-1393099-3](#) [6-1393099-8](#) [6-1393122-4](#) [6-1393123-2](#) [6-1393767-1](#) [6-1393843-7](#) [6-1415012-1](#) [6-1419102-2](#) [6-](#)
[1423698-4](#) [6-1608051-6](#) [6-1608067-0](#) [6-1616170-6](#) [6-1616248-2](#) [6-1616282-3](#) [6-1616348-2](#) [6-1616350-1](#) [6-1616350-8](#) [6-1616358-7](#) [6-](#)
[1616359-9](#) [6-1616360-9](#) [6-1616931-6](#) [6-1617039-1](#) [6-1617052-1](#) [6-1617090-2](#) [6-1617090-5](#) [6-1617347-5](#) [6-1617353-3](#) [6-1617801-8](#) [6-](#)
[1617802-2](#) [6-1618107-9](#) [6-1618248-4](#) [M83536/1-027M](#) [CX-4014](#) [MAHC-5494](#) [MAVCD-5419-6](#) [703XCX-120A](#) [7-1393100-5](#) [7-1393111-7](#)
[7-1393144-5](#) [7-1393767-8](#)