



**OMC Edge Lit Backlight Panel - Emitter Specification.**

**< Backlight Applications >**

- \* Panel Meters
- \* Audio Systems
- \* Control Panels
- \* Instrument / Equipment



**< Maximum Ratings (Ta=25°C)>**

Reverse Voltage	10.0V
D.C forward current	30mA
Pulse current (10% duty cycle 0.1ms pulse width)	100mA
Operating temperature range	-25°C to +85°C
Storage temperature range	-25°C to +100°C
Lead soldering temperature (1.6mm from body)	+260°C for 5 Secs

**< Electrical / Optical Characteristics at Ta=25°C >**

Backlight Series Part No.	LED Chip		Backlight Panel Color	Wavelength Typ.	Forward Voltage		Luminous Intensity Per Emitter		Viewing Angle
	Material	Emitting Color		IF@20mA (nm)	IF@20mA (V)		IF@20mA (mcd)		2θ 1/2 (Deg)
				λ d	Typ.	Max.	Min.	Typ.	
BR02xxx	GaP	Green	Yellow/Green	572	4.2	4.8	20	30	50
BRIYxxx	GaAlP on GaAs	Yellow	Yellow	595	4.2	4.8	90	150	50
BRUBxxx	InGaN	Blue	White	470	7.6	9.4	80	170	50
BRURxxx	GaAlAs on GaAs	Red	Red	660	3.4	4.4	100	150	50

**< Package Dimensions >**

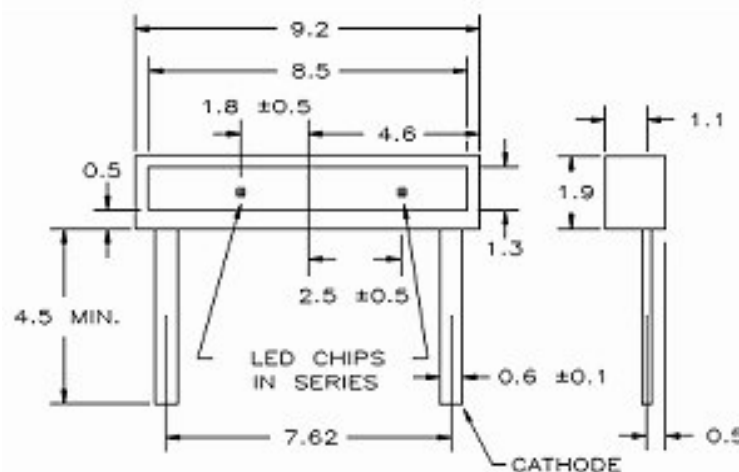

- \* Tolerance : + / - 0.25 mm
- \* All dimensions are in mm.



**OMC edge lit backlights** are available in a variety of colours, each of which have their own advantage, they are also available in a wide variety of sizes and options, such as Bi-colour.

- 1) Yellow/Green -  
The Industry standard backlight colour at 567nm is very cost effective.
- 2) High Brightness Yellow/Orange -  
A bright, rich and warm 595nm colour which is pleasing to the eye and gives a high quality look to any product.
- 3) High Brightness Blue -  
A very bright blue at 470nm creating a striking and distinctive display.
- 4) High Brightness Red -  
A bright red 660nm makes the display stand out from the others.

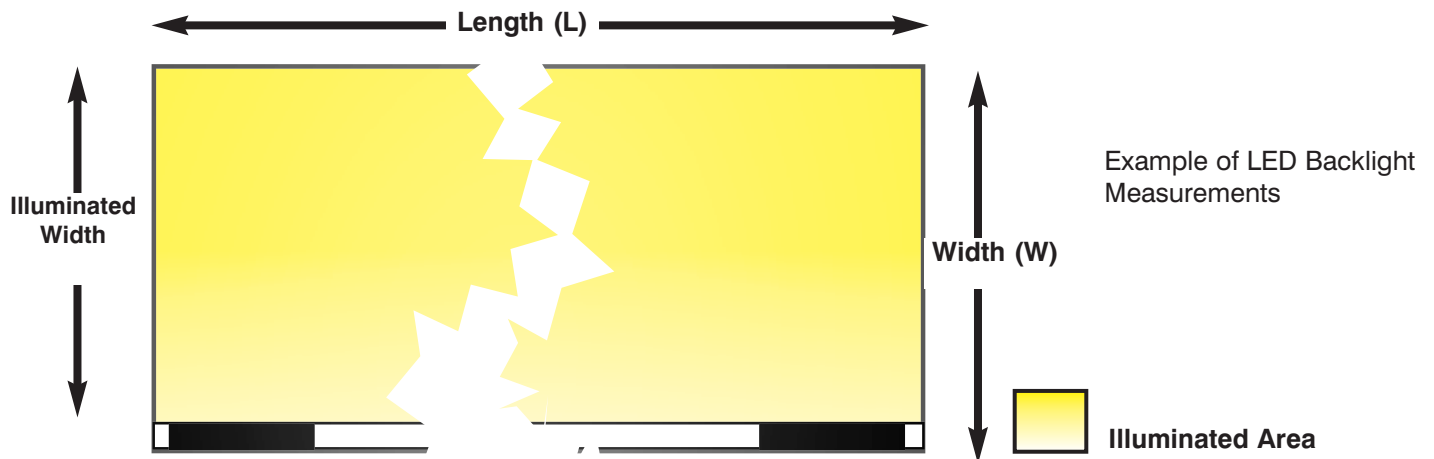
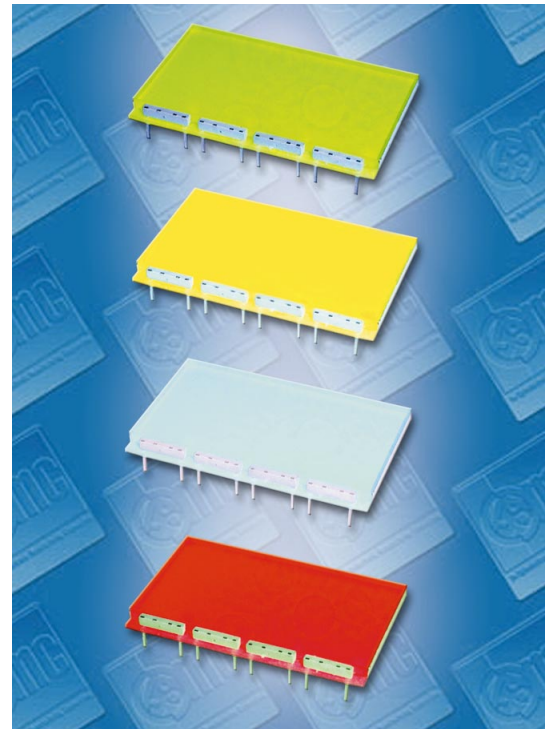

The Backlights can also be illuminated from different points, depending on the application, to produce the best results and utilisation of circuit board space.

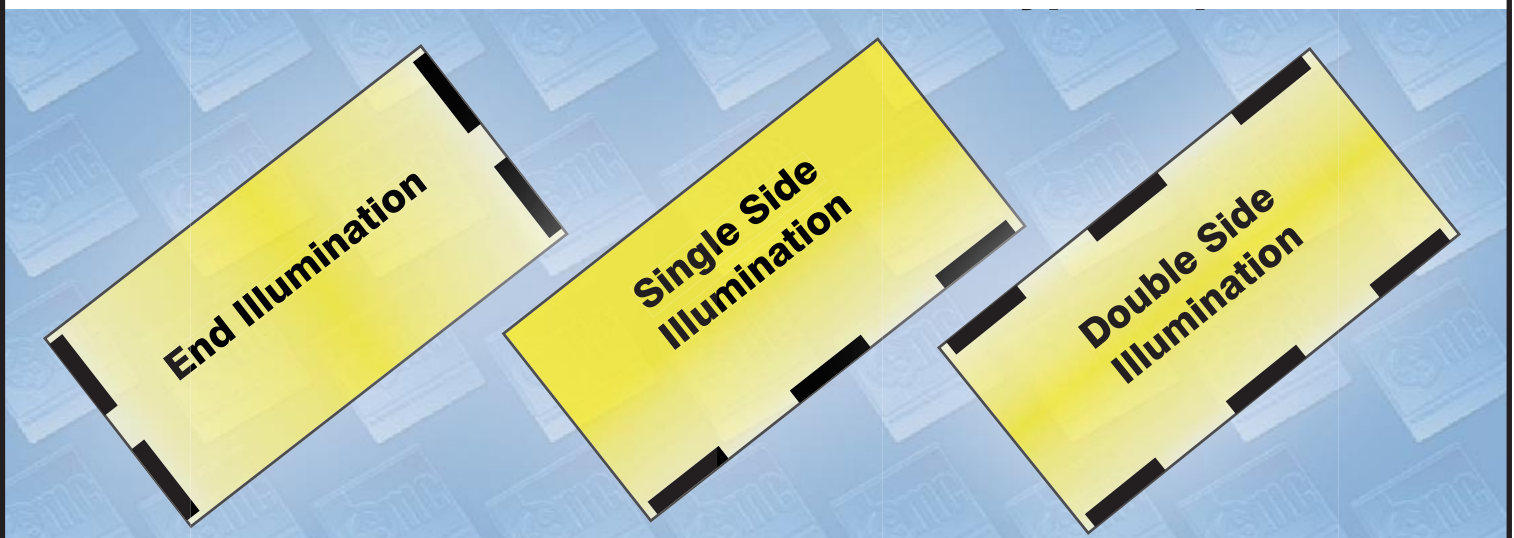



OMC Backlight	Description	Fits Following LCDs	Overall Panel Size LxWxH	Illuminated Area LxW	Number of Emitters
<b>S36 Types</b>					
BR02S3604TE	Standard Yellow/Green Type	233-651	47.50 x 17.00 x 3.0mm	47.50 x 14.50mm	4
BRIYS3604TE	High Brightness Yellow/Orange Type	233-651	47.50 x 17.00 x 3.0mm	47.50 x 14.50mm	4
BRUBS3604TE	High Brightness Blue Type	233-651	47.50 x 17.00 x 3.0mm	47.50 x 14.50mm	4
BRURS3604TE	High Brightness Red Type	233-651	47.50 x 17.00 x 3.0mm	47.50 x 14.50mm	4
<b>S36 Types</b>					
BR02S3804TE	Standard Yellow/Green Type	253-558, 233-640, 233-638	48.70 x 23.30 x 3.0mm	48.70 x 20.80mm	4
BRIYS3804TE	High Brightness Yellow/Orange Type	253-558, 233-640, 233-638	48.70 x 23.30 x 3.0mm	48.70 x 20.80mm	4
BRUBS3804TE	High Brightness Blue Type	253-558, 233-640, 233-638	48.70 x 23.30 x 3.0mm	48.70 x 20.80mm	4
BRURS3804TE	High Brightness Red Type	253-558, 233-640, 233-638	48.70 x 23.30 x 3.0mm	48.70 x 20.80mm	4
<b>S19 Types</b>					
BR02S1906TE	Standard Yellow/Green Type	523-227, 253-560	67.00 x 28.50 x 3.0mm	67.00 x 26.00mm	6
BRIYS1906TE	High Brightness Yellow/Orange Type	523-227, 253-560	67.00 x 28.50 x 3.0mm	67.00 x 26.00mm	6
BRUBS1906TE	High Brightness Blue Type	523-227, 253-560	67.00 x 28.50 x 3.0mm	67.00 x 26.00mm	6
BRURS1906TE	High Brightness Red Type	523-227, 253-560	67.00 x 28.50 x 3.0mm	67.00 x 26.00mm	6
<b>S152 Bi-Colour Type</b>					
BSRGS15208TE	U/B Red - Green Bi-Colour	233-651	46.50 x 19.50 x 3.0mm	47.50 x 14.50mm	4 x G, 4 x R
<b>S153 Bi-Colour Type</b>					
BSRGS15308TE	U/B Red - Green Bi-Colour	253-558, 233-640, 233-638	48.70 x 25.80 x 3.0mm	48.70 x 20.80mm	4 x G, 4 x R
<b>S154 Bi-Colour Type</b>					
BSRGS15412TE	U/B Red - Green Bi-Colour	253-560	67.00 x 31.00 x 3.0mm	67.00 x 26.00mm	6 x G, 6 x R
<b>S155 Bi-Colour Type</b>					
BSRGS15512TE	U/B Red - Green Bi-Colour	523-227	67.00 x 28.00 x 3.0mm	67.00 x 23.00mm	6 x G, 6 x R

Bi-Colour backlights offer the ability to change colour from Green to Bright Red.

This is achieved by using a neutral colour reflector and having two rows of LED's one edge having all green emitters the opposite edge having all Red.

These backlights can be used to indicate an alarm state on an LCD and draw the users attention to reading a particular display.

The backlights ability to change colour means it can be used as an indicator without having to add additional LED's to a products front panel.

Bi-Colour backlights can be used to good effect for example on a temperature display

if the temperature is within a set range the backlight can remain green in the event of an over or under temperature

state the backlight can be made to change colour alerting the user to a possible fault.

## **X-ON Electronics**

Largest Supplier of Electrical and Electronic Components

*Click to view similar products for [led technology manufacturer](#):*

Other Similar products are found below :

[L02R5000Q1](#) [LTR24S3706YG](#) [BRURS3804TE](#) [FDC003](#) [LTR74S3804R](#) [L02R3000F1](#) [LT1802-24](#) [L08R5000Q1](#) [L03R5000Q1](#)  
[L4RR5000E1](#)