



# GS4911B/GS4910B HD/SD/Graphics Clock and Timing Generator with GENLOCK

## Key Features

### Video Clock Synthesis

- Generates any video or graphics clock up to 165MHz
- Pre-programmed for 8 video and 13 graphics clocks
- Accuracy of free-running clock frequency limited only by crystal reference
- One differential and two single-ended video/graphics clock outputs
- Each clock may be individually delayed for skew control
- Video output clock may be directly connected to Gennum's serializers for a SMPTE-compliant HD-SDI output

### Audio Clock Synthesis (GS4911B only)

- Three audio clock outputs
- Generates any audio clock up to 512\*96kHz
- Pre-programmed for 7 audio clocks

### Timing Generation

- Generates up to 8 timing signals at a time
- Choose from 9 pre-programmed timing signals: H and V sync and blanking, F Sync, F Digital, AFS (GS4911B only), Display Enable, 10FID, and up to 4 user-defined timing signals
- Pre-programmed to generate timing for 35 different video formats and 13 different graphic display formats

### Genlock Capability

- Clocks may be free-running or genlocked to an input reference with a variable offset step size of 100-200ps (depending on exact clock frequency)
- Variable timing offset step size of 100-200ps up to one frame
- Output may be cross-locked to a different input reference
- Freeze operation on loss of reference
- Optional crash or drift lock on application of reference
- Automatic input format detection

### General Features

- Reduces design complexity and saves board space - 9mm x 9mm package plus crystal reference replaces multiple VCXOs, PLLs and timing generators
- Pb-free and RoHS Compliant
- Low power operation typically 300mW
- 1.8V core and 1.8V or 3.3V I/O power supplies
- 64-PIN QFN package

## Applications

- Video cameras; Digital audio and/or video recording/play back devices; Digital audio and/or video processing devices; Computer/video displays; DVD/MPEG devices; Digital Set top boxes; Video projectors; High definition video systems; Multi-media PC applications

## Description

The GS4911B is a highly flexible, digitally controlled clock synthesis circuit and timing generator with genlock capability. It can be used to generate video and audio clocks and timing signals, and allows multiple devices to be genlocked to an input reference.

The GS4910B includes all the features of the GS4911B, but does not offer audio clocks or AFS pulse generation.

The GS4911B/GS4910B will recognize input reference signals conforming to 36 different video standards and 16 different graphic formats, and will genlock the output timing information to the incoming reference. The GS4911B/GS4910B supports cross-locking, allowing the output to be genlocked to an incoming reference that is different from the output video standard selected.

The user may select to output one of 8 different video sample clock rates or 13 different graphic display clock rates, or may program any clock frequency between 13.5MHz and 165MHz. The chosen clock frequency can be further divided using internal dividers, and is available on two video clock outputs and one LVDS video clock output pair. The video clocks are frequency and phased-locked to the horizontal timing reference, and can be individually delayed with respect to the timing outputs for clock skew control.

Eight user-selectable timing outputs are provided that can automatically produce the following timing signals for 35 different video formats and 13 different graphics formats: HSync, Hblanking, VSync, Vblanking, F sync, F digital, AFS (GS4911B only), DE, and 10FID. These timing outputs may be locked to the input reference signal for genlock timing and may be phase adjusted via internal registers.

In addition, the GS4911B provides three audio sample clock outputs that can produce audio clocks up to 512fs with fs ranging from 9.7kHz to 96kHz. Audio to video phasing is accomplished by an external 10FID input reference, a 10FID signal specified via internal registers, or a user-programmed audio frame sequence.

The GS4911B/GS4910B is Pb-free, and the encapsulation compound does not contain halogenated flame retardant (RoHS Compliant).

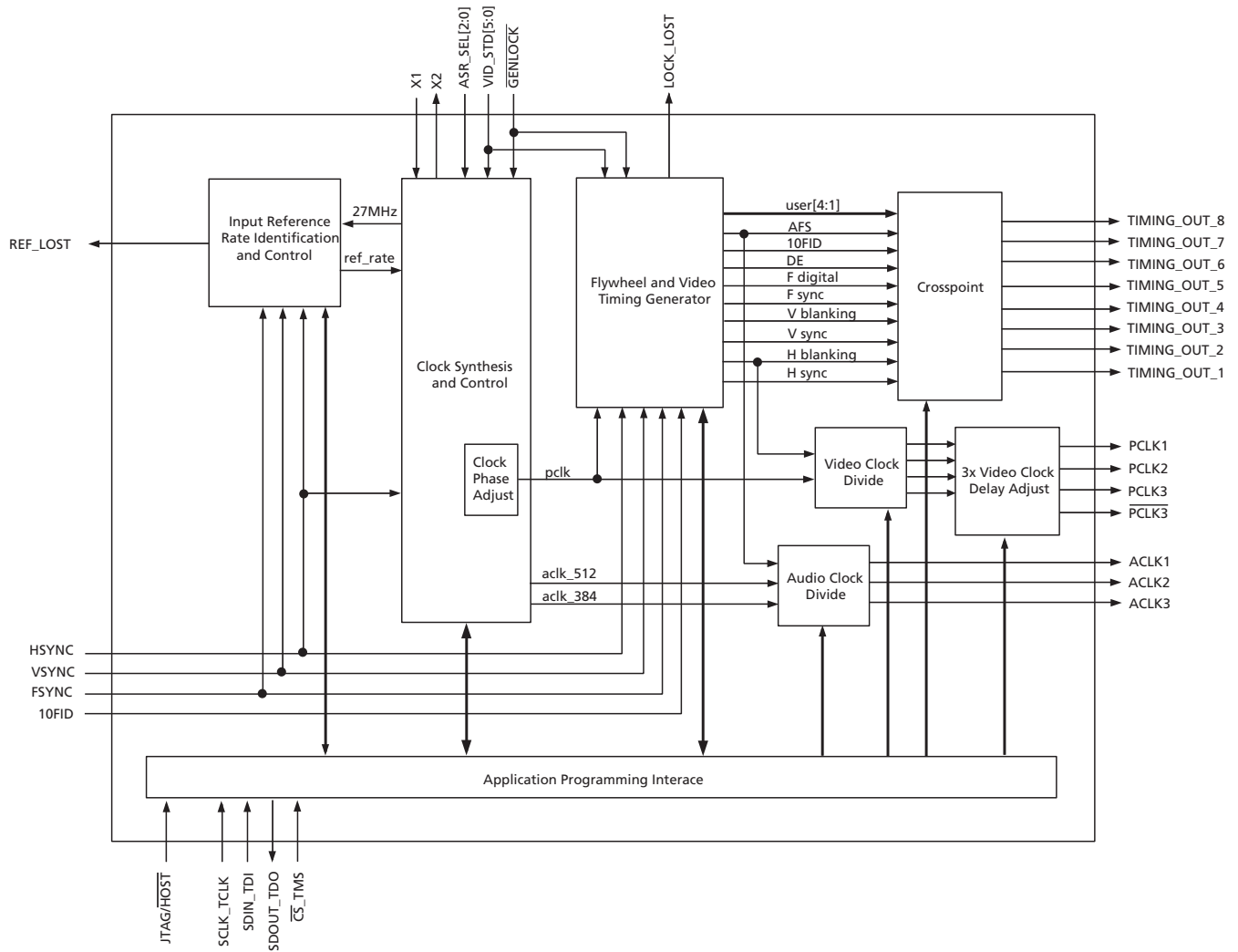

**GS4911B Functional Block Diagram**

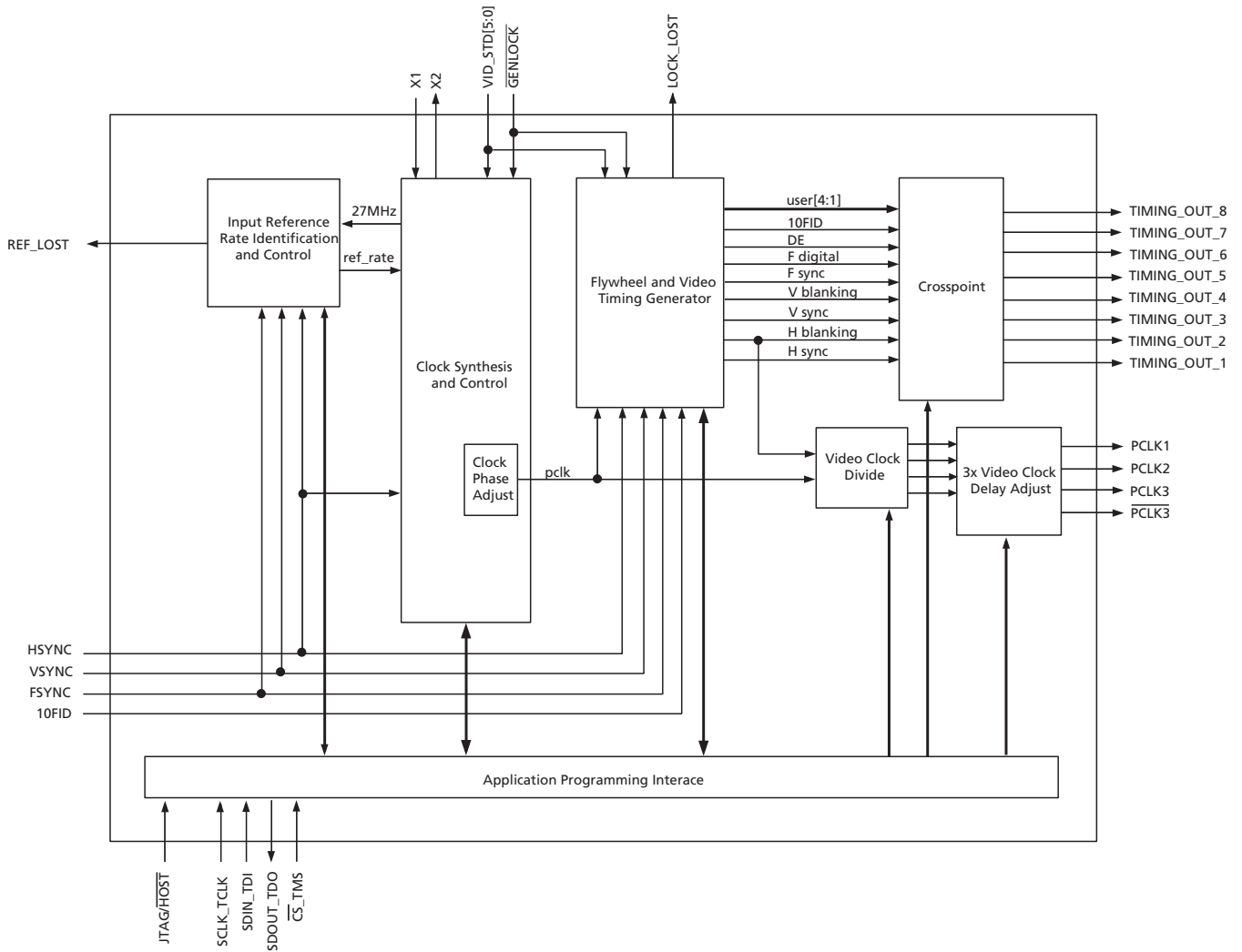

**GS4910B Functional Block Diagram**

## Revision History

Version	ECR	PCN	Date	Changes and/or Modifications
5	151938	–	June 2009	Updated document with new template.
4	144904	–	April 2007	Corrected H_Offset value in <a href="#">3.2.1.1 Genlock Timing Offset</a> .
3	141424	40495	August 2006	Updated terminal width to 0.25+/-0.05 on <a href="#">Package Dimensions</a> and pin 1 ID change to 45° chamfer.
2	139291	38723	April 2006	Corrected description and formulas for loop bandwidth. Converted to Data Sheet. Clarified setting of VID_STD in Extended Audio Mode. Updated power consumption of GS4910B.
1	138866	37792	December 2005	Corrected phrasing regarding user-programmable outputs. Added note on V Blanking output width for VID_STD=4, 6, 8. Corrected ESD protection to 1kV.
0	138004	–	November 2005	New document.

# Contents

Key Features .....	1
Applications.....	1
Description.....	1
Revision History .....	4
1. Pin Out.....	8
1.1 GS4911B Pin Assignment .....	8
1.2 GS4910B Pin Assignment .....	9
1.3 Pin Descriptions .....	10
1.4 Pre-Programmed Recognized Video and Graphics Standards .....	20
1.5 Output Timing Signals .....	26
2. Electrical Characteristics .....	30
2.1 Absolute Maximum Ratings .....	30
2.2 DC Electrical Characteristics .....	30
2.3 AC Electrical Characteristics .....	33
3. Detailed Description.....	37
3.1 Functional Overview .....	37
3.2 Modes of Operation .....	37
3.2.1 Genlock Mode.....	38
3.2.2 Free Run Mode .....	41
3.3 Output Timing Format Selection .....	42
3.4 Input Reference Signals .....	43
3.4.1 HSYNC, VSYNC, and FSYNC.....	43
3.4.2 10FID .....	44
3.4.3 Automatic Polarity Recognition .....	45
3.5 Reference Format Detector .....	45
3.5.1 Horizontal and Vertical Timing Characteristic Measurements .....	45
3.5.2 Input Reference Validity.....	46
3.5.3 Behaviour on Loss and Re-acquisition of the Reference Signal.....	47
3.5.4 Allowable Frequency Drift on the Reference .....	49
3.6 Genlock .....	50
3.6.1 Automatic Locking Process .....	50
3.6.2 Manual Locking Process.....	54
3.6.3 Adjustable Locking Time.....	58
3.6.4 Adjustable Loop Bandwidth .....	58
3.6.5 Locking to Digital Timing from a Deserializer .....	60
3.7 Clock Synthesis .....	61
3.7.1 Video Clock Synthesis.....	61
3.7.2 Audio Clock Synthesis (GS4911B only).....	63
3.8 Video Timing Generator .....	67
3.8.1 10 Field ID Pulse.....	67
3.8.2 Audio Frame Synchronizing Pulse (GS4911B only).....	68
3.8.3 USER_1~4 .....	69

3.8.4 TIMING_OUT Pins .....	71
3.9 Custom Clock Generation .....	72
3.9.1 Programming a Custom Video Clock.....	72
3.9.2 Programming a Custom Audio Clock (GS4911B only) .....	73
3.10 Custom Output Timing Signal Generation .....	74
3.10.1 Custom Input Reference .....	75
3.11 Extended Audio Mode for HD Demux using the Gennum Audio Core .....	75
3.12 GSPI Host Interface .....	76
3.12.1 Command Word Description .....	77
3.12.2 Data Read and Write Timing .....	78
3.12.3 Configuration and Status Registers.....	79
3.13 JTAG .....	110
3.14 Device Power-Up .....	111
3.14.1 Power Supply Sequencing .....	111
3.15 Device Reset .....	111
4. Application Reference Design .....	112
4.1 GS4911B Typical Application Circuit .....	112
4.2 GS4910B Typical Application Circuit .....	113
5. References & Relevant Standards .....	114
6. Package & Ordering Information .....	115
6.1 Package Dimensions .....	115
6.2 Solder Reflow Profiles .....	116
6.3 Recommended PCB Footprint .....	117
6.4 Packaging Data .....	117
6.5 Ordering Information .....	118

## List of Figures

GS4911B Functional Block Diagram .....	2
GS4910B Functional Block Diagram .....	3
Figure 1-1: XTAL1 and XTAL2 Reference Circuits .....	20
Figure 2-1: PCLK to TIMING_OUT Signal Output Timing .....	36
Figure 3-1: HD-SD Calculation .....	40
Figure 3-2: Output Accuracy and Modes of Operation .....	42
Figure 3-3: Example HSYNC, VSYNC, and FSYNC Analog Input Timing from a Sync Separator .....	43
Figure 3-4: Example H Blanking, V Blanking, and F Digital Input Timing from an SDI Deserializer .....	44
Figure 3-5: 10FID Input Timing .....	45
Figure 3-6: Internal Video Genlock Block .....	54
Figure 3-7: Internal Audio Genlock Block .....	56
Figure 3-8: Default 10FID Output Timing .....	67
Figure 3-9: Optional 10FID Output Timing .....	68
Figure 3-10: AFS Output Timing .....	69
Figure 3-11: USER Programmable Output Signal .....	70

Figure 3-12: Custom Timing Parameters .....	74
Figure 3-13: Audio Clock Block Diagram for HD Demux Operation .....	76
Figure 3-14: GSPI Application Interface Connection .....	77
Figure 3-15: Command Word Format .....	77
Figure 3-16: Data Word Format .....	78
Figure 3-17: GSPI Read Mode Timing .....	79
Figure 3-18: GSPI Write Mode Timing .....	79
Figure 3-19: In-Circuit JTAG .....	110
Figure 3-20: System JTAG .....	111
Figure 6-1: Maximum Pb-free Solder Reflow Profile (preferred) .....	116
Figure 6-2: Standard Pb Solder Reflow Profile .....	116

## List of Tables

Table 1-1: Pin Descriptions .....	10
Table 1-2: Recognized Video and Graphics Standards .....	21
Table 1-3: Output Timing Signals .....	26
Table 2-1: DC Electrical Characteristics .....	30
Table 2-2: AC Electrical Characteristics .....	33
Table 2-3: Suggested External Crystal Specification .....	36
Table 3-1: Clock_Phase_Offset[15:0] Encoding Scheme.....	39
Table 3-2: Ambiguous Standard Identification .....	47
Table 3-3: Max_Ref_Delta Encoding Scheme.....	49
Table 3-4: Cross-reference Genlock Table.....	52
Table 3-5: Integer Constant Value.....	57
Table 3-6: Video Clock Phase Adjustment Host Settings.....	62
Table 3-7: Audio Sample Rate Select.....	63
Table 3-8: Audio Clock Divider .....	64
Table 3-9: Encoding Scheme for AFS_Reset_Window .....	65
Table 3-10: Audio Sampling Frequency to Video Frame Rate Synchronization.....	66
Table 3-11: Crosspoint Select.....	71
Table 3-12: GSPI Timing Parameters .....	78
Table 3-13: Configuration and Status Registers.....	79
Table 5-1: References & Relevant Standards .....	114

# 1. Pin Out

## 1.1 GS4911B Pin Assignment

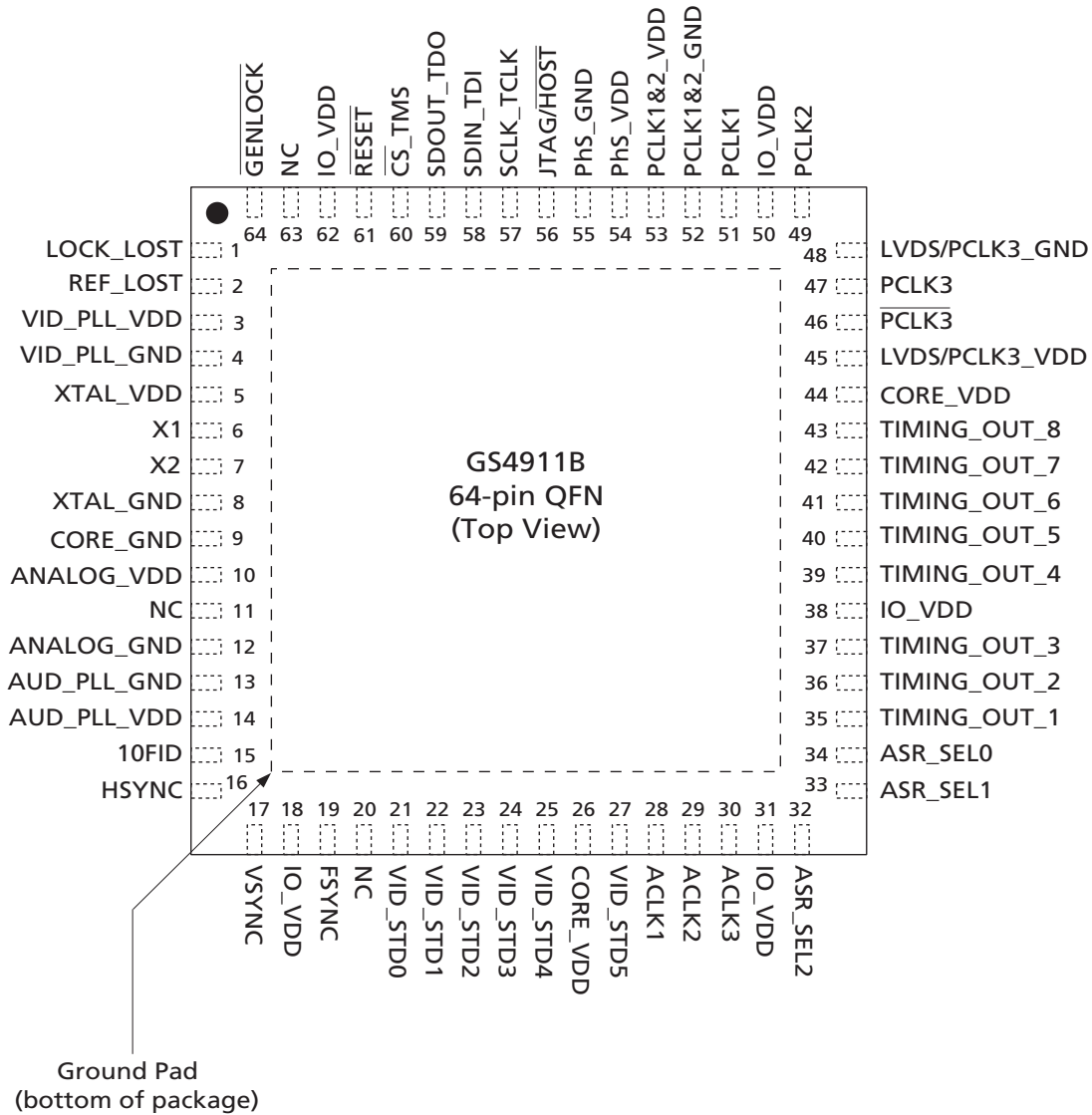



## 1.2 GS4910B Pin Assignment

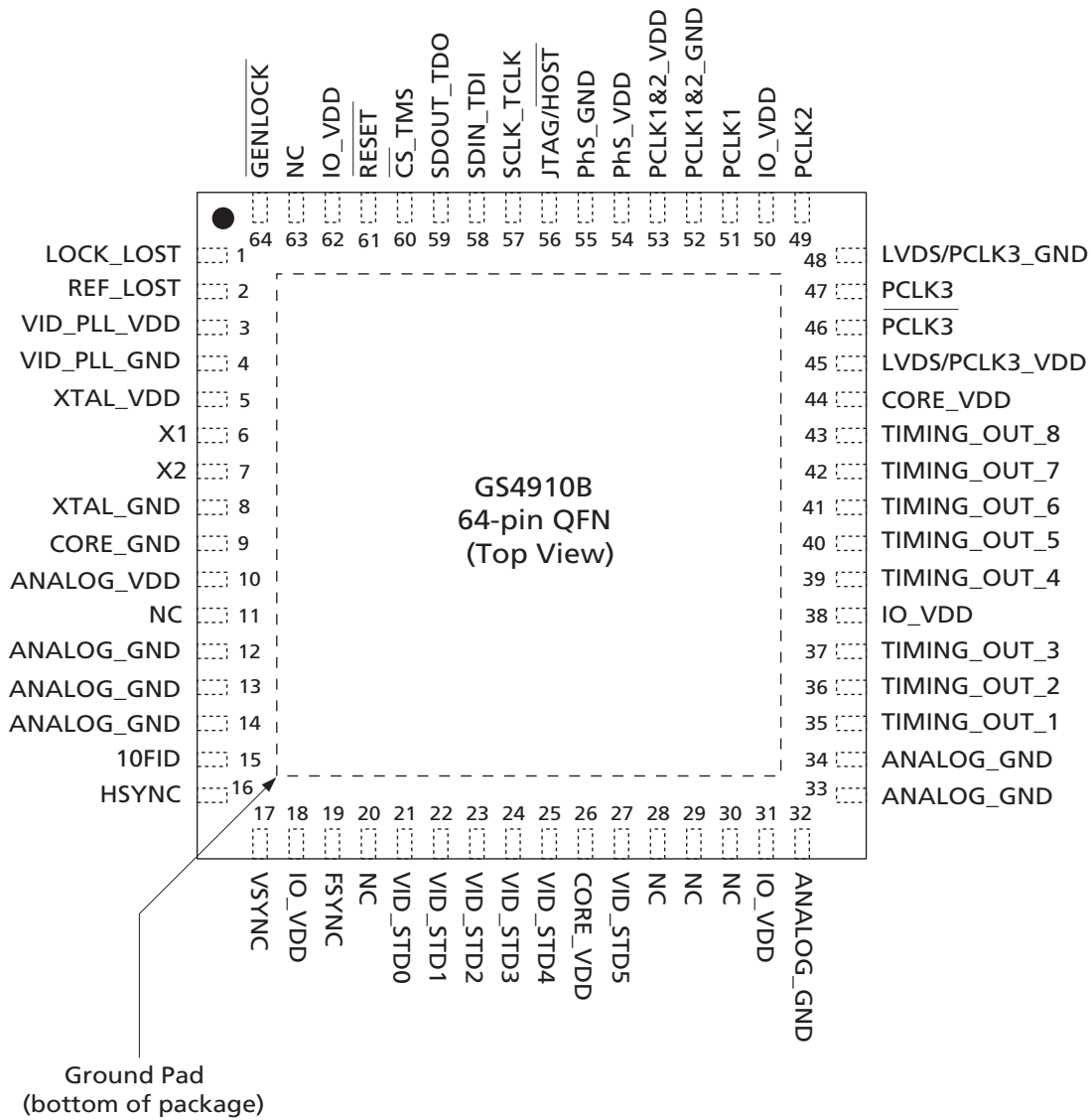

## 1.3 Pin Descriptions

Table 1-1: Pin Descriptions

Pin Number	Name	Timing	Type	Description
1	LOCK_LOST	Non Synchronous	Output	<p>STATUS SIGNAL OUTPUT Signal levels are LVCMOS/LVTTL compatible.</p> <p>This pin will be HIGH if the output is not genlocked to the input. The GS4911B/GS4910B monitors the output pixel/line counters, as well as the internal lock status from the genlock block and asserts LOCK_LOST HIGH if it is determined that the output is not genlocked to the input. This pin will be LOW if the device successfully genlocks the output clock and timing signals to the input reference.</p> <p>If LOCK_LOST is LOW, the reference timing generator outputs will be phase locked to the detected reference signal, producing an output in accordance with the video standard selected by the VID_STD[5:0] pins.</p>
2	REF_LOST	Non Synchronous	Output	<p>STATUS SIGNAL OUTPUT Signal levels are LVCMOS/LVTTL compatible.</p> <p>This pin will be HIGH if:</p> <ul style="list-style-type: none"> <li>No input reference signal is applied to the device; or</li> <li>The input reference applied does not meet the minimum/maximum timing requirements described in <a href="#">Section 3.5.2 on page 46</a>.</li> </ul> <p>This pin will be LOW otherwise.</p> <p>If the reference signal is removed when the device is in Genlock mode, REF_LOST will go HIGH and the GS4911B/GS4910B will enter Freeze mode (see <a href="#">Section 3.2.1.2 on page 41</a>).</p>
3	VID_PLL_VDD	–	Power Supply	Most positive power supply connection for the video clock synthesis internal block. Connect to +1.8V DC.
4	VID_PLL_GND	–	Power Supply	Ground connection for the video clock synthesis internal block. Connect to GND.
5	XTAL_VDD	–	Power Supply	Most positive power supply connection for the crystal buffer. Connect to either +1.8V DC or +3.3V DC. NOTE: Connect to +3.3V for minimum output PCLK jitter.
6	X1	Non Synchronous	Input	<p>ANALOG SIGNAL INPUT Connect to a 27MHz crystal or a 27MHz external clock source. See <a href="#">Figure 1-1</a>.</p>
7	X2	Non Synchronous	Output	<p>ANALOG SIGNAL OUTPUT Connect to a 27MHz crystal, or leave this pin open circuit if an external clock source is applied to pin 6. See <a href="#">Figure 1-1</a>.</p>
8	XTAL_GND	–	Power Supply	Ground connection for the crystal buffer. Connect to GND.

**Table 1-1: Pin Descriptions (Continued)**

Pin Number	Name	Timing	Type	Description
9	CORE_GND	–	Power Supply	Ground connection for core and I/O. Solder to the ground plane of the application board.  NOTE: The CORE_GND pin should be soldered to the same main ground plane as the exposed ground pad on the bottom of the device.
10	ANALOG_VDD	–	Power Supply	Most positive power supply connection for the analog input block. Connect to +1.8V DC.
11, 20, 63	NC	–	–	Do not connect.
12	ANALOG_GND	–	Power Supply	Ground connection for the analog input block. Connect to GND.
13	AUD_PLL_GND (GS4911B only)	–	Power Supply	Ground connection for the audio clock synthesis internal block. Connect to GND.
	ANALOG_GND (GS4910B only)	–	Power Supply	Ground connection for the analog input block. Connect to GND.
14	AUD_PLL_VDD (GS4911B only)	–	Power Supply	Most positive power supply connection for the audio clock synthesis internal block. Connect to +1.8V DC.
	ANALOG_GND (GS4910B only)	–	Power Supply	Ground connection for the analog input block. Connect to GND.
15	10FID	Non Synchronous	Input	REFERENCE SIGNAL INPUT Signal levels are LVCMOS/LVTTL compatible.  The 10FID external reference signal is applied to this pin by the application layer. 10FID defines the field in which the video and audio clock phase relationship is defined according to SMPTE 318-M. It is also used to define a 3:2 video cadence.  NOTE: If the input reference format does not include a 10 Field ID signal, this pin should be held LOW. See <a href="#">Section 3.4.2 on page 44</a> .
16	HSYNC	Non Synchronous	Input	REFERENCE SIGNAL INPUT Signal levels are LVCMOS/LVTTL compatible.  The HSYNC external reference signal is applied to this pin by the application layer. When the GS4911B/GS4910B is operating in Genlock mode, the device senses the polarity of the HSYNC input automatically, and references to the leading edge.  If the user wishes to select one of the pre-programmed video and/or timing output signals provided by the device, then this signal must adhere to one of the 36 defined video or 16 different graphics display standards supported by the device. In this mode of operation, the HSYNC input provides a horizontal scanning reference signal.  The HSYNC signal may have analog timing, such as from a sync separator, or may be digital such as from an SDI deserializer. <a href="#">Section 1.4 on page 20</a> describes the 36 video formats and 16 graphic formats recognized by the GS4911B/GS4910B.

**Table 1-1: Pin Descriptions (Continued)**

Pin Number	Name	Timing	Type	Description
17	VSYNC	Non Synchronous	Input	<p>REFERENCE SIGNAL INPUT Signal levels are LVCMOS/LVTTL compatible.</p> <p>The VSYNC external reference signal is applied to this pin by the application layer. When the GS4911B/GS4910B is operating in Genlock mode, the device senses the polarity of the VSYNC input automatically, and references to the leading edge.</p> <p>If the user wishes to select one of the pre-programmed video and/or timing output signals provided by the device, then this signal must adhere to one of the 36 defined video or 16 different graphics display standards supported by the device. In this mode of operation, the VSYNC input provides a vertical scanning reference signal.</p> <p>The VSYNC signal may have analog timing, such as from a sync separator, or may be digital such as from an SDI deserializer. <a href="#">Section 1.4 on page 20</a> describes the 36 video formats and 16 graphic formats recognized by the GS4911B/GS4910B.</p>
18, 31, 38, 50, 62	IO_VDD	–	Power Supply	<p>Most positive power supply connection for the digital I/O signals. Connect to either +1.8V DC or +3.3V DC.</p> <p>NOTE: All five IO_VDD pins must be powered by the same voltage.</p>
19	FSYNC	Non Synchronous	Input	<p>REFERENCE SIGNAL INPUT Signal levels are LVCMOS/LVTTL compatible.</p> <p>The FSYNC external reference signal is applied to this pin by the application layer.</p> <p>The first field is defined as the field in which the first broad pulse (also known as serration) is in the first half of a line. The FSYNC signal should be set HIGH during the first field for sync-based references.</p> <p>If the user wishes to select one of the pre-programmed video and/or timing output signals provided by the device, then this signal must adhere to one of the 36 defined video or 16 different graphics display standards supported by the device. In this mode of operation, the FSYNC input provides an odd/even field input reference.</p> <p>The FSYNC signal may have analog timing, such as from a sync separator, or may be digital such as from an SDI deserializer. <a href="#">Section 1.4 on page 20</a> describes the 36 video formats and 16 graphic formats recognized by the GS4911B/GS4910B.</p> <p>For blanking-based references, the FSYNC signal should be set HIGH during the second field.</p> <p>NOTE: If the input reference format does not include an F sync signal, this pin should be held LOW.</p>

**Table 1-1: Pin Descriptions (Continued)**

Pin Number	Name	Timing	Type	Description
27, 25, 24, 23, 22, 21	VID_STD[5:0]	Non Synchronous	Input	<p>CONTROL SIGNAL INPUTS Signal levels are LVCMOS/LVTTL compatible.</p> <p>Video Standard Select.</p> <p>Used to select the desired video/graphic display format for video clock and timing signal generation.</p> <p>8 different video and 13 different graphic sample clocks, as well as 35 different video format and 13 different graphic format timing signal outputs may be selected using these pins.</p> <p>For details on the supported video standards and video clock frequency selection, please see <a href="#">Section 1.4 on page 20</a>.</p>
26, 44	CORE_VDD	–	Power Supply	Most positive power supply connection for the digital core. Connect to +1.8V DC.
28, 29, 30	ACLK1 ACLK2 ACLK3 (GS4911B only)	–	Output	<p>CLOCK SIGNAL OUTPUTS Signal levels are LVCMOS/LVTTL compatible.</p> <p>Audio output clock signals.</p> <p>ACLK1, ACLK2, and ACLK3 present audio sample rate clock outputs to the application layer.</p> <p>By default, after system reset, the audio clock output pins of the device provide clock signals as follows:</p> <p>ACLK1 = 256fs                      ACLK2 = 64fs                      ACLK3 = fs, where fs is the fundamental sampling frequency.</p> <p>The fundamental sampling frequency is selected using ASR_SEL[2:0]. Additional sampling frequencies may be programmed in the host interface.</p> <p>It is also possible to select different division ratios for each of the audio clock outputs by programming designated registers in the host interface. Clock outputs of 512fs, 384fs, 256fs, 192fs, 128fs, 64fs, fs and z bit are selectable on a pin-by-pin basis.</p> <p>NOTE: ACLK1-3 will have a 50% duty cycle, unless fs is selected as 96kHz and the host interface is configured such that one of the three ACLK pins is set to output a clock signal at 192fs or 384fs. If this is the case, then a 512fs clock will have a 33% duty cycle.</p> <p>These signals will be high impedance when ASR_SEL[2:0] = 000b.</p>
	NC (GS4910B only)	–	–	Do not connect.
32, 33, 34	ASR_SEL[2:0] (GS4911B only)	Non Synchronous	Input	<p>CONTROL SIGNAL INPUTS Signal levels are LVCMOS/LVTTL compatible.</p> <p>Audio Sample Rate Select.</p> <p>Used to select the fundamental sampling frequency, fs, of the audio clock outputs. See <a href="#">Table 3-7</a>.</p> <p>When ASR_SEL[2:0] = 000b, audio clock generation will be disabled and the ACLK1 to ACLK3 pins will be high impedance. In this case, AUD_PLL_VDD (pin 14) may be connected to GND to minimize noise and power consumption.</p>
	ANALOG_GND (GS4910B only)	–	Power Supply	Ground connection for the analog input block. Connect to GND.

**Table 1-1: Pin Descriptions (Continued)**

Pin Number	Name	Timing	Type	Description
35	TIMING_OUT_1	Synchronous with PCLK1 ~ PCLK3	Output	<p>TIMING SIGNAL OUTPUT Signal levels are LVCMOS/LVTTL compatible. Selectable timing output.</p> <p>Selectable from: H sync; H blanking; V sync; V blanking; F sync; F digital; Display Enable; 10 field ID (film cadence); AFS video/audio timing (GS4911B only); USER_1~4.</p> <p>See <a href="#">Section 1.5 on page 26</a> for signal descriptions.</p> <p>NOTE: Default output is H Sync.</p> <p>The current drive capability of this pin may be set high or low via designated registers in the host interface. By default, the current drive will be low.</p> <p>This signal will be high impedance when VID_STD[5:0] = 00h.</p>
36	TIMING_OUT_2	Synchronous with PCLK1 ~ PCLK3	Output	<p>TIMING SIGNAL OUTPUT Signal levels are LVCMOS/LVTTL compatible. Selectable timing output.</p> <p>Selectable from: H sync; H blanking; V sync; V blanking; F sync; F digital; Display Enable; 10 field ID (film cadence); AFS video/audio timing (GS4911B only); USER_1~4.</p> <p>See <a href="#">Section 1.5 on page 26</a> for signal descriptions.</p> <p>NOTE: Default output is H blanking.</p> <p>The current drive capability of this pin may be set high or low via designated registers in the host interface. By default, the current drive will be low.</p> <p>This signal will be high impedance when VID_STD[5:0] = 00h.</p>
37	TIMING_OUT_3	Synchronous with PCLK1 ~ PCLK3	Output	<p>TIMING SIGNAL OUTPUT Signal levels are LVCMOS/LVTTL compatible. Selectable timing output.</p> <p>Selectable from: H sync; H blanking; V sync; V blanking; F sync; F digital; Display Enable; 10 field ID (film cadence); AFS video/audio timing (GS4911B only); USER_1~4.</p> <p>See <a href="#">Section 1.5 on page 26</a> for signal descriptions.</p> <p>NOTE: Default output is V Sync.</p> <p>The current drive capability of this pin may be set high or low via designated registers in the host interface. By default, the current drive will be low.</p> <p>This signal will be high impedance when VID_STD[5:0] = 00h.</p>

**Table 1-1: Pin Descriptions (Continued)**

Pin Number	Name	Timing	Type	Description
39	TIMING_OUT_4	Synchronous with PCLK1 ~ PCLK3	Output	<p>TIMING SIGNAL OUTPUT Signal levels are LVCMOS/LVTTL compatible. Selectable timing output.</p> <p>Selectable from: H sync; H blanking; V sync; V blanking; F sync; F digital; Display Enable; 10 field ID (film cadence); AFS video/audio timing (GS4911B only); USER_1~4.</p> <p>See <a href="#">Section 1.5 on page 26</a> for signal descriptions.</p> <p>NOTE: Default output is V blanking.</p> <p>The current drive capability of this pin may be set high or low via designated registers in the host interface. By default, the current drive will be low.</p> <p>This signal will be high impedance when VID_STD[5:0] = 00h.</p>
40	TIMING_OUT_5	Synchronous with PCLK1 ~ PCLK3	Output	<p>TIMING SIGNAL OUTPUT Signal levels are LVCMOS/LVTTL compatible. Selectable timing output.</p> <p>Selectable from: H sync; H blanking; V sync; V blanking; F sync; F digital; Display Enable; 10 field ID (film cadence); AFS video/audio timing (GS4911B only); USER_1~4.</p> <p>See <a href="#">Section 1.5 on page 26</a> for signal descriptions.</p> <p>NOTE: Default output is F Sync.</p> <p>The current drive capability of this pin may be set high or low via designated registers in the host interface. By default, the current drive will be low.</p> <p>This signal will be high impedance when VID_STD[5:0] = 00h.</p>
41	TIMING_OUT_6	Synchronous with PCLK1 ~ PCLK3	Output	<p>TIMING SIGNAL OUTPUT Signal levels are LVCMOS/LVTTL compatible. Selectable timing output.</p> <p>Selectable from: H sync; H blanking; V sync; V blanking; F sync; F digital; Display Enable; 10 field ID (film cadence); AFS video/audio timing (GS4911B only); USER_1~4.</p> <p>See <a href="#">Section 1.5 on page 26</a> for signal descriptions.</p> <p>NOTE: Default output is F digital.</p> <p>The current drive capability of this pin may be set high or low via designated registers in the host interface. By default, the current drive will be low.</p> <p>This signal will be high impedance when VID_STD[5:0] = 00h.</p>

**Table 1-1: Pin Descriptions (Continued)**

Pin Number	Name	Timing	Type	Description
42	TIMING_OUT_7	Synchronous with PCLK1 ~ PCLK3	Output	<p>TIMING SIGNAL OUTPUT Signal levels are LVCMOS/LVTTL compatible. Selectable timing output.</p> <p>Selectable from: H sync; H blanking; V sync; V blanking; F sync; F digital; Display Enable; 10 field ID (film cadence); AFS video/audio timing (GS4911B only); USER_1~4.</p> <p>See <a href="#">Section 1.5 on page 26</a> for signal descriptions.</p> <p>NOTE: Default output is 10 Field ID (10FID).</p> <p>The current drive capability of this pin may be set high or low via designated registers in the host interface. By default, the current drive will be low.</p> <p>This signal will be high impedance when VID_STD[5:0] = 00h.</p>
43	TIMING_OUT_8	Synchronous with PCLK1 ~ PCLK3	Output	<p>TIMING SIGNAL OUTPUT Signal levels are LVCMOS/LVTTL compatible. Selectable timing output.</p> <p>Selectable from: H sync; H blanking; V sync; V blanking; F sync; F digital; Display Enable; 10 field ID (film cadence); AFS video/audio timing (GS4911B only); USER_1~4.</p> <p>See <a href="#">Section 1.5 on page 26</a> for signal descriptions.</p> <p>NOTE: Default output is Display Enable (DE).</p> <p>The current drive capability of this pin may be set high or low via designated registers in the host interface. By default, the current drive will be low.</p> <p>This signal will be high impedance when VID_STD[5:0] = 00h.</p>
45	LVDS/PCLK3_VDD	–	Power Supply	<p>Most positive power supply connection for PCLK3 output circuitry and LVDS driver. Connect to +1.8V DC.</p>
46, 47	$\overline{\text{PCLK3}}$ , PCLK3	–	Output	<p>CLOCK SIGNAL OUTPUTS Signal levels are LVDS compatible. Differential video clock output signal.</p> <p><math>\overline{\text{PCLK3}}</math>/<math>\overline{\text{PCLK3}}</math> present a differential video sample rate clock output to the application layer.</p> <p>By default, after system reset, this output will operate at the fundamental frequency determined by the setting of the VID_STD[5:0] pins. It is possible to define other non-standard fundamental clock rates using the host interface.</p> <p>It is also possible to select different division ratios for the <math>\overline{\text{PCLK3}}</math>/<math>\overline{\text{PCLK3}}</math> outputs by programming designated registers in the host interface. A clock output of the fundamental rate, fundamental rate <math>\div 2</math>, or fundamental rate <math>\div 4</math> may be selected.</p> <p>The <math>\overline{\text{PCLK3}}</math>/<math>\overline{\text{PCLK3}}</math> outputs will be high impedance when VID_STD[5:0] = 00h.</p>
48	LVDS/PCLK3_GND	–	Power Supply	<p>Ground connection for PCLK3 output circuitry and LVDS driver. Connect to GND.</p>



**Table 1-1: Pin Descriptions (Continued)**

Pin Number	Name	Timing	Type	Description
49	PCLK2	–	Output	<p>CLOCK SIGNAL OUTPUT Signal levels are LVCMOS/LVTTL compatible.</p> <p>Video clock output signal.</p> <p>PCLK2 presents a video sample rate clock output to the application layer.</p> <p>By default, after system reset, the PCLK2 output pin will operate at the fundamental frequency determined by the setting of the VID_STD[5:0] pins. It is possible to define other non-standard fundamental clock rates using the host interface.</p> <p>It is also possible to select different division ratios for the PCLK2 output by programming designated registers in the host interface. A clock output of the fundamental rate, fundamental rate <math>\div 2</math>, or fundamental rate <math>\div 4</math> may be selected.</p> <p>By setting designated registers in the host interface, the current drive capability of this pin may be set high or low. By default, the current drive will be low. It must be set high if the clock rate is greater than 100MHz.</p> <p>The PCLK2 output will be held LOW when VID_STD[5:0] = 00h.</p>
51	PCLK1	–	Output	<p>CLOCK SIGNAL OUTPUT Signal levels are LVCMOS/LVTTL compatible.</p> <p>Video clock output signal.</p> <p>PCLK1 presents a video sample rate clock output to the application layer.</p> <p>By default, after system reset, the PCLK1 output pin will operate at the fundamental frequency determined by the setting of the VID_STD[5:0] pins. It is possible to define other non-standard fundamental clock rates using the host interface.</p> <p>It is also possible to select different division ratios for the PCLK1 output by programming designated registers in the host interface. A clock output of the fundamental rate, fundamental rate <math>\div 2</math>, or fundamental rate <math>\div 4</math> may be selected.</p> <p>By setting designated registers in the host interface, the current drive capability of this pin may be set high or low. By default, the current drive will be low. It must be set high if the clock rate is greater than 100MHz.</p> <p>The PCLK1 output will be held LOW when VID_STD[5:0] = 00h.</p>
52	PCLK1&2_GND	–	Power Supply	Ground connection for PCLK1&2 circuitry. Connect to GND.
53	PCLK1&2_VDD	–	Power Supply	Most positive power supply connection for PCLK1&2 circuitry. Connect to +1.8V DC.
54	PhS_VDD	–	Power Supply	Most positive power supply connection for the video clock phase shift internal block. Connect to +1.8V DC.
55	PhS_GND	–	Power Supply	Ground connection for the video clock phase shift internal block. Connect to GND.

**Table 1-1: Pin Descriptions (Continued)**

Pin Number	Name	Timing	Type	Description
56	JTAG/ $\overline{\text{HOST}}$	Non Synchronous	Input	<p>CONTROL SIGNAL INPUT Signal levels are LVCMOS/LVTTL compatible.</p> <p>Used to select JTAG Test Mode or Host Interface Mode.</p> <p>When set HIGH, <math>\overline{\text{CS\_TMS}}</math>, SCLK_TCLK, SDOUT_TDO, and SDIN_TDI are configured for JTAG boundary scan testing.</p> <p>When set LOW, <math>\overline{\text{CS\_TMS}}</math>, SCLK_TCLK, SDOUT_TDO, and SDIN_TDI are configured as GSPI pins for normal host interface operation.</p>
57	SCLK_TCLK	Non Synchronous	Input	<p>SIGNAL INPUT Signal levels are LVCMOS/LVTTL compatible.</p> <p>Serial Data Clock / Test Clock.</p> <p>All JTAG / Host Interface address and data are shifted into/out of the device synchronously with this clock.</p> <p>Host Mode (JTAG/<math>\overline{\text{HOST}}</math> = LOW): SCLK_TCLK operates as the host interface serial data clock, SCLK.</p> <p>JTAG Test Mode (JTAG/<math>\overline{\text{HOST}}</math> = HIGH): SCLK_TCLK operates as the JTAG test clock, TCLK.</p>
58	SDIN_TDI	Synchronous with SCLK_TCLK	Input	<p>SIGNAL INPUT Signal levels are LVCMOS/LVTTL compatible.</p> <p>Serial Data Input / Test Data Input.</p> <p>Host Mode (JTAG/<math>\overline{\text{HOST}}</math> = LOW): SDIN_TDI operates as the host interface serial input, SDIN, used to write address and configuration information to the internal registers of the device.</p> <p>JTAG Test Mode (JTAG/<math>\overline{\text{HOST}}</math> = HIGH): SDIN_TDI operates as the JTAG test data input, TDI.</p>
59	SDOUT_TDO	Synchronous with SCLK_TCLK	Output	<p>SIGNAL INPUT Signal levels are LVCMOS/LVTTL compatible.</p> <p>Serial Data Output / Test Data Output.</p> <p>Host Mode (JTAG/<math>\overline{\text{HOST}}</math> = LOW): SDOUT_TDO operates as the host interface serial output, SDOUT, used to read status and configuration information from the internal registers of the device.</p> <p>JTAG Test Mode (JTAG/<math>\overline{\text{HOST}}</math> = HIGH): SDOUT_TDO operates as the JTAG test data output, TDO.</p>
60	$\overline{\text{CS\_TMS}}$	Synchronous with SCLK_TCLK	Input	<p>SIGNAL INPUT Signal levels are LVCMOS/LVTTL compatible.</p> <p>Chip Select / Test Mode Select.</p> <p>Host Mode (JTAG/<math>\overline{\text{HOST}}</math> = LOW): <math>\overline{\text{CS\_TMS}}</math> operates as the host interface chip select, <math>\overline{\text{CS}}</math>, and is active LOW.</p> <p>JTAG Test Mode (JTAG/<math>\overline{\text{HOST}}</math> = HIGH): <math>\overline{\text{CS\_TMS}}</math> operates as the JTAG test mode select, TMS, and is active HIGH.</p>

**Table 1-1: Pin Descriptions (Continued)**

Pin Number	Name	Timing	Type	Description
61	$\overline{\text{RESET}}$	Non Synchronous	Input	<p>CONTROL SIGNAL INPUT Signal levels are LVCMOS/LVTTL compatible.</p> <p>Used to reset the internal operating conditions to their default settings or to reset the JTAG test sequence.</p> <p>Host Mode (JTAG/<math>\overline{\text{HOST}}</math> = LOW): When asserted LOW, all host registers and functional blocks will be set to their default conditions. All input and output signals will become high impedance, except PCLK1 and PCLK2, which will be set LOW.</p> <p>When set HIGH, normal operation of the device will resume.</p> <p>The user must hold this pin LOW during power-up and for a minimum of 500 uS after the last supply has reached its operating voltage.</p> <p>JTAG Test Mode (JTAG/<math>\overline{\text{HOST}}</math> = HIGH): When asserted LOW, all host registers and functional blocks will be set to their default conditions and the JTAG test sequence will be held in reset.</p> <p>When set HIGH, normal operation of the JTAG test sequence will resume.</p>
64	$\overline{\text{GENLOCK}}$	Non Synchronous	Input	<p>CONTROL SIGNAL INPUT Signal levels are LVCMOS/LVTTL compatible.</p> <p>Selects Genlock mode or Free Run mode.</p> <p>When this pin is set LOW and the device has successfully genlocked the output to the input reference, the device will enter Genlock mode. The video clock and timing outputs will be frequency and phase locked to the detected reference signal.</p> <p>When this pin is set HIGH, the video clock and the reference-timing generator will free-run.</p> <p>By default, the GS4911B's audio clocks will be genlocked to the output video clock regardless of the setting of this pin.</p> <p>NOTE: The user must apply a reference to the input of the device prior to setting <math>\overline{\text{GENLOCK}}</math> = LOW. If the <math>\overline{\text{GENLOCK}}</math> pin is set LOW and no reference signal is present, the generated clock and timing outputs of the device may correspond to the internal default settings of the chip until a reference is applied.</p>
–	Ground Pad	–	–	Ground pad on bottom of package must be soldered to main ground plane of PCB.

External Crystal Connection

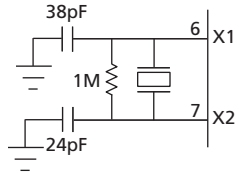

External Clock Source Connection

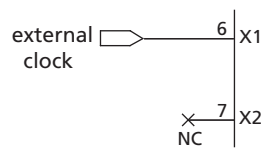

## Notes:

1. Capacitor values listed represent the total capacitance, including discrete capacitance and parasitic board capacitance.
2. X1 serves as an input, which may alternatively accept a 27MHz clock source. To accommodate this, mismatched capacitor values are recommended.

Figure 1-1: XTAL1 and XTAL2 Reference Circuits

## 1.4 Pre-Programmed Recognized Video and Graphics Standards

Table 1-2 describes the video and graphics standards automatically recognized by the GS4911B/GS4910B. Any one of the 36 different video formats and 16 different graphic display formats listed below can be applied to the GS4911B/GS4910B and automatically detected by the reference format detector. Moreover, each format, with the exception of VID\_STD[5:0] = 2, 52, 53, or 54, is available for output on the timing output pins by setting the VID\_STD[5:0] pins.

In addition to the pre-programmed video standards listed in Table 1-2, custom output timing signals may be generated by the GS4911B/GS4910B. The custom timing parameters are programmed in the host interface when VID\_STD[5:0] is set to 62 (see Section 3.10 on page 74).

Setting VID\_STD[5:0] to 63 will cause the device to produce an output format with identical timing to the detected input reference.

If desired, the external VID\_STD[5:0] pins may be ignored by setting bit 1 of the Video\_Control register, and the video standard may instead be selected via the VID\_STD[5:0] register of the host interface (see Section 3.12.3 on page 79). Although the external VID\_STD[5:0] pins will be ignored in this case, they should not be left floating.

**Table 1-2: Recognized Video and Graphics Standards**

VID_STD [5:0]	System Nomenclature	Video PCLK Frequency (MHz)	PCLKS/ Total Line	Total Lines / Frame	PCLKS / Active Line	H Sync Width (Clocks)	H Sync Polarity	V Sync Width (Lines)	V Sync Polarity	Active Lines / Frame	Scan Format Standard
0	PCLK1 & 2 = LOW. PCLK3/PCLK3 = High Impedance	-	-	-	-	-	-	-	-	-	-
1	4fsc 525 / 2:1 interlace	14.32	910	525	768	67	negative	3	negative	486	SMPTE 244M
2*	Composite PAL 625 / 2:1 interlace / 25	-	-	625	-	-	negative	2.5	negative	576	-
3	601 525 / 2:1 interlace	27	1716	525	1440	127	negative	3	negative	486	SMPTE 125M/267M
4#	601 625 / 2:1 interlace	27	1728	625	1440	127	negative	2.5	negative	576	ITU-R BT.601-5
5	601 – 18MHz 525 / 2:1 interlace	36	2288	525	1920	169	negative	3	negative	486	SMPTE 267M
6#	601 – 18 MHz 625 / 2:1 interlace	36	2304	625	1920	169	negative	2.5	negative	576	ITU-R BT.601-5
7	720x486/59.94/2:1 interlace	54	3432	525	2880	252	negative	3	negative	486	SMPTE RP174 / SMPTE 347M
8#	720x576/50/2:1 interlace	54	3456	625	2880	252	negative	2.5	negative	576	ITU-R BT.799 / SMPTE 347M
9	720x483/59.94/1:1 progressive	54	1716	525	1440	127	negative	6	negative	483	SMPTE 293M / SMPTE 347M
10	720x576/50/1:1 progressive	54	1728	625	1440	127	negative	5	negative	576	ITU-R BT.1358 / SMPTE 347M
11	1280x720/60/1:1 progressive	74.25	1650	750	1280	80	tri	5	negative	720	SMPTE 296M
12	1280x720/59.94/1:1 progressive	74.175	1650	750	1280	80	tri	5	negative	720	SMPTE 296M

**Table 1-2: Recognized Video and Graphics Standards (Continued)**

VID_STD [5:0]	System Nomenclature	Video PCLK Frequency (MHz)	PCLKS/ Total Line	Total Lines / Frame	PCLKS / Active Line	H Sync Width (Clocks)	H Sync Polarity	V Sync Width (Lines)	V Sync Polarity	Active Lines / Frame	Scan Format Standard
13	1280/720/50/1:1 progressive	74.25	1980	750	1280	80	tri	5	negative	720	SMPTE 296M
14	1280x720/30/1:1 progressive	74.25	3300	750	1280	80	tri	5	negative	720	SMPTE 296M
15	1280x720/29.97/1:1 progressive	74.175	3300	750	1280	80	tri	5	negative	720	SMPTE 296M
16	1280x720/25/1:1 progressive	74.25	3960	750	1280	80	tri	5	negative	720	SMPTE 296M
17	1280x720/24/1:1 progressive	74.25	4125	750	1280	80	tri	5	negative	720	SMPTE 296M
18	1280x720/23.98/1:1 progressive	74.175	4125	750	1280	80	tri	5	negative	720	SMPTE 296M
19	1920x1035/60/2:1 interlace	74.25	2200	1125	1920	80	tri	5	negative	1035	SMPTE 260M
20	1920x1035/59.94/2:1 interlace	74.175	2200	1125	1920	80	tri	5	negative	1035	SMPTE 260M
21	1920x1080/60/1:1 progressive	148.5	2200	1125	1920	80	tri	5	negative	1080	SMPTE 274M
22	1920x1080/59.94/1:1 progressive	148.35	2200	1125	1920	80	tri	5	negative	1080	SMPTE 274M
23	1920x1080/50/1:1 progressive	148.5	2640	1125	1920	80	tri	5	negative	1080	SMPTE 274M
24	Reserved	-	-	-	-	-	-	-	-	-	-
25	1920x1080/60/2:1 interlace	74.25	2200	1125	1920	80	tri	5	negative	1080	SMPTE 274M
26	1920x1080/59.94/2:1 interlace	74.175	2200	1125	1920	80	tri	5	negative	1080	SMPTE 274M

**Table 1-2: Recognized Video and Graphics Standards (Continued)**

VID_STD [5:0]	System Nomenclature	Video PCLK Frequency (MHz)	PCLKS/ Total Line	Total Lines / Frame	PCLKS / Active Line	H Sync Width (Clocks)	H Sync Polarity	V Sync Width (Lines)	V Sync Polarity	Active Lines / Frame	Scan Format Standard
27	1920x1080/50/2:1 interlace	74.25	2640	1125	1920	80	tri	5	negative	1080	SMPTE 274M
28	Reserved	-	-	-	-	-	-	-	-	-	-
29	1920x1080/30/1:1 progressive	74.25	2200	1125	1920	80	tri	5	negative	1080	SMPTE 274M
30	1920x1080/30/PsF	74.25	2200	1125	1920	80	tri	5	negative	1080	SMPTE RP 211
31	1920x1080/29.97/1:1 progressive	74.175	2200	1125	1920	80	tri	5	negative	1080	SMPTE 274M
32	1920x1080/29.97/PsF	74.175	2200	1125	1920	80	tri	5	negative	1080	SMPTE RP 211
33	1920x1080/25/1:1 progressive	74.25	2640	1125	1920	80	tri	5	negative	1080	SMPTE 274M
34	1920x1080/25/PsF	74.25	2640	1125	1920	80	tri	5	negative	1080	SMPTE RP 211
35	1920x1080/24/1:1 progressive	74.25	2750	1125	1920	80	tri	5	negative	1080	SMPTE 274M
36	1920x1080/24/PsF	74.25	2750	1125	1920	80	tri	5	negative	1080	SMPTE RP 211
37	1920x1080/23.98/1:1 progressive	74.175	2750	1125	1920	80	tri	5	negative	1080	SMPTE 274M
38	1920x1080/23.98/PsF	74.175	2750	1125	1920	80	tri	5	negative	1080	SMPTE RP 211
39	640 x 480 VGA @ 60 Hz	25.2	800	525	640	96	negative	2	negative	480	IBM Standard
40	640 x 480 VGA @ 75 Hz	31.5	840	500	640	64	negative	3	negative	480	VESA VDM75HZ
41	640 x 480 VGA @ 85 Hz	36	832	509	640	56	negative	3	negative	480	VESA VDM75HZ
42	800 x 600 SVGA @ 60 Hz	40.00	1056	628	800	128	positive	4	positive	600	VESA VG900602

**Table 1-2: Recognized Video and Graphics Standards (Continued)**

VID_STD [5:0]	System Nomenclature	Video PCLK Frequency (MHz)	PCLKS/ Total Line	Total Lines / Frame	PCLKS / Active Line	H Sync Width (Clocks)	H Sync Polarity	V Sync Width (Lines)	V Sync Polarity	Active Lines / Frame	Scan Format Standard
43	800 x 600 SVGA @ 75 Hz	49.5	1056	625	800	80	positive	3	positive	600	VESA VDMT75HZ
44	800 x 600 SVGA @ 85 Hz	56.25	1048	631	800	64	positive	3	positive	600	VESA VDMTPROP
45	1024 x 768 XGA @ 60 Hz	65	1344	806	1024	136	negative	6	negative	768	VESA VG901101A
46	1024 x 768 XGA @ 75 Hz	78.75	1312	800	1024	96	positive	3	positive	768	VESA VDMT75HZ
47	1024 x 768 XGA @ 85 Hz	94.5	1376	808	1024	96	negative	3	positive	768	VESA VDMTPROP
48	1280 x 1024 SXGA @ 60 Hz	108.00	1688	1066	1280	112	positive	3	positive	1024	VESA VDMTREV
49	1280 x 1024 SXGA @ 75 Hz	135.00	1688	1066	1280	144	negative	3	positive	1024	VESA VDMT75HZ
50	1280 x 1024 SXGA @ 85 Hz	157.5	1728	1072	1280	160	negative	3	positive	1024	VESA VDMTPROP
51†	1600 x 1200 UXGA @ 60 Hz	162	2160	1250	1600	192	negative	3	positive	1200	VESA VDMTPROP
52*	1600 x 1200 UXGA @ 75 Hz	-	-	1250	-	-	negative	3	positive	1200	-
53*	1600 x 1200 UXGA @ 85 Hz	-	-	1250	-	-	negative	3	positive	1200	-
54*	2048 x 1536 QXGA @ 60 Hz	-	-	1589	-	-	negative	3	positive	1536	-
55 - 61	Reserved	-	-	-	-	-	-	-	-	-	-
62	Custom format only (Section 3.10 on page 74)	-	-	-	-	-	-	-	-	-	-



**Table 1-2: Recognized Video and Graphics Standards (Continued)**

VID_STD [5:0]	System Nomenclature	Video PCLK Frequency (MHz)	PCLKS / Total Line	Total Lines / Frame	PCLKS / Active Line	H Sync Width (Clocks)	H Sync Polarity	V Sync Width (Lines)	V Sync Polarity	Active Lines / Frame	Scan Format Standard
63	Automatic Output Standard follows Input Standard	-	-	-	-	-	-	-	-	-	-

\* VID\_STD[5:0] = 2, 52, 53, and 54 are recognized as input references only. To generate clock and timing signals for these standards use the device's custom format capability.  
 † The LOCK\_LOST output signal will be unstable when attempting to genlock to an input reference corresponding to VID\_STD[5:0] = 51, although the device does achieve lock. To correct this, the user can program register address 27h = 38d.  
 ‡ When VID\_STD = 4, 6, or 8, the Vblanking output pulse width is 2 lines too long for field 1 and 1 line too short for field 2 when compared to the digital timing defined in ITU-R BT.656 and ITU-R BT.799.  
 NOTE: 1080i/60 to VGA/60 is not a valid locking option.

## 1.5 Output Timing Signals

Table 1-3 describes the output timing signals available to the user via pins TIMING\_OUT\_1 to TIMING\_OUT\_8. The user may output any of the signals listed below on each pin by programming the Output\_Select registers beginning at address 43h of the host interface.

**Table 1-3: Output Timing Signals**

Signal Name	Description	Default Output Pin
H Sync	<p>The H Sync signal has a leading edge at the start of the horizontal sync pulse. Its length is determined by the selected video standard (see Table 1-2), or according to custom timing parameters programmed in the host interface (see Section 3.10 on page 74).</p> <p>The width of the H Sync output pulse is determined by the selected video standard. Table 1-2 lists the H Sync width (in clocks) of each pre-programmed video and graphics standard recognized by the GS4911B/GS4910B. Custom video timing parameters may also be programmed in the host interface to define a unique H Sync width (see Section 3.10 on page 74).</p> <p>In Genlock mode the leading edge of the output H Sync signal is nominally simultaneous with the half amplitude point of the reference HSYNC input. This timing may be offset using the Genlock Offset registers beginning at address 1Bh of the host interface (see Section 3.2.1.1 on page 38).</p> <p>By default, after system reset, the polarity of the H Sync signal output will be active LOW. The polarity may be selected as active HIGH by programming the Polarity register at address 56h of the host interface (see Section 3.12.3 on page 79).</p>	TIMING_OUT_1
H Blanking	<p>The H Blanking signal is used to indicate the portion of the video line not containing active video data.</p> <p>The H Blanking signal will be LOW (default polarity) for the portion of the video line containing valid video samples. The signal will be LOW at the first valid pixel of the line, and HIGH after the last valid pixel of the line.</p> <p>The H Blanking signal remains HIGH throughout the horizontal blanking period.</p> <p>The width of this signal will be determined by the selected video standard (see Table 1-2), or according to custom timing parameters programmed in the host interface (see Section 3.10 on page 74).</p> <p>When in Genlock mode, the output H Blanking signal will be phase locked to the reference HSYNC input. This timing may be offset using the Genlock Offset registers beginning at address 1Bh of the host interface (see Section 3.2.1.1 on page 38).</p> <p>The default polarity of this signal may be inverted by programming the Polarity register at address 56h of the host interface (see Section 3.12.3 on page 79).</p>	TIMING_OUT_2

**Table 1-3: Output Timing Signals (Continued)**

Signal Name	Description	Default Output Pin
V Sync	<p>The V Sync timing signal has a leading edge at the start of the vertical sync pulse. Its length is determined by the selected video standard (see <a href="#">Table 1-2</a>), or according to custom timing parameters programmed in the host interface (see <a href="#">Section 3.10 on page 74</a>).</p> <p>The leading edge of V Sync is nominally simultaneous with the leading edge of the first broad pulse.</p> <p>When in Genlock mode, the output V Sync signal will be phase locked to the reference VSYNC input. This timing may be offset using the Genlock Offset registers beginning at address 1Bh of the host interface (see <a href="#">Section 3.2.1.1 on page 38</a>).</p> <p>By default, after system reset, the polarity of the V Sync signal output will be active LOW. The polarity may be selected as active HIGH by programming the Polarity register at address 56h of the host interface (see <a href="#">Section 3.12.3 on page 79</a>).</p>	TIMING_OUT_3
V Blanking	<p>The V Blanking signal is used to indicate the portion of the video field/frame not containing active video lines.</p> <p>The V Blanking signal will be LOW (default polarity) for the portion of the field/frame containing valid video data, and will be HIGH throughout the vertical blanking period.</p> <p>The width of this signal will be determined by the selected video standard (see <a href="#">Table 1-2</a>), or according to custom timing parameters programmed in the host interface (see <a href="#">Section 3.10 on page 74</a>).</p> <p>When in Genlock mode, the output V Blanking signal will be phase locked to the reference VSYNC input. This timing may be offset using the Genlock Offset registers beginning at address 1Bh of the host interface (see <a href="#">Section 3.2.1.1 on page 38</a>).</p> <p>The default polarity of this signal may be inverted by programming the Polarity register at address 56h of the host interface (see <a href="#">Section 3.12.3 on page 79</a>).</p> <p>NOTE: When VID_STD = 4, 6, or 8, the Vblank output pulse width is 2 lines too long for field 1 and 1 line too short for field 2 when compared to the digital timing defined in ITU-R BT.656 and ITU-R BT.799.</p>	TIMING_OUT_4
F Sync	<p>The F Sync signal is used to indicate field 1 and field 2 for interlaced video formats.</p> <p>The F Sync signal will be HIGH (default polarity) for the entire period of field 1. It will be LOW for all lines in field 2 and for all lines in progressive scan systems.</p> <p>The width and timing of this signal will be determined by the V Sync parameters of the selected video standard (see <a href="#">Table 1-2</a>), or according to custom V Sync timing parameters programmed in the host interface (see <a href="#">Section 3.10 on page 74</a>). The F Sync signal always changes state on the leading edge of V Sync.</p> <p>When in Genlock mode, the output F Sync signal will be phase locked to the reference FSYNC input. This timing may be offset using the Genlock Offset registers beginning at address 1Bh of the host interface (see <a href="#">Section 3.2.1.1 on page 38</a>).</p> <p>The default polarity of this signal may be inverted by programming the Polarity register at address 56h of the host interface (see <a href="#">Section 3.12.3 on page 79</a>).</p>	TIMING_OUT_5

**Table 1-3: Output Timing Signals (Continued)**

Signal Name	Description	Default Output Pin
F Digital	<p>F Digital is used in digital interlaced standards to indicate field 1 and field 2.</p> <p>The F Digital changes state at the leading edge of every V Blanking pulse. It will be LOW (default polarity) for the entire period of field 1 and for all lines in progressive scan systems. It will be HIGH for all lines in field 2.</p> <p>The width and timing of this signal will be determined by the timing parameters of the selected video standard (see <a href="#">Table 1-2</a>), or according to custom parameters programmed in the host interface (see <a href="#">Section 3.10 on page 74</a>).</p> <p>When in Genlock mode, the output F Digital signal will be phase locked to the reference FSYNC input. This timing may be offset using the Genlock Offset registers beginning at address 1Bh of the host interface (see <a href="#">Section 3.2.1.1 on page 38</a>).</p> <p>The default polarity of this signal may be inverted by programming the Polarity register at address 56h of the host interface (see <a href="#">Section 3.12.3 on page 79</a>).</p>	TIMING_OUT_6
10 Field Identification	<p>The 10 Field Identification (10FID) signal is used to indicate the 10-field sequence for 29.97Hz, 30Hz, 59.94Hz and 60Hz video standards. It will be LOW for output standards with other frame rates.</p> <p>The sequence defines the phase relationship between film frames and video frames, so that cadence may be maintained in mixed format environments.</p> <p>The 10FID signal will be HIGH (default polarity) for one line at the start of the 10-field sequence. It will be LOW for all other lines. The signal's rising and falling edges will be simultaneous with the leading edge of the H Sync output signal.</p> <p>Alternatively, by setting bit 4 of the Video_Control register (see <a href="#">Section 3.12.3 on page 79</a>), the 10FID output signal may be configured to go HIGH (default polarity) on the leading edge of the H Sync output on line 1 of the first field in the 10 field sequence, and be reset LOW on the leading edge of the H Sync pulse of the first line of the second field in the 10 field sequence.</p> <p>When in Genlock mode, the output 10FID signal will be phase locked to the 10FID reference input. If a 10FID input is not provided to the device, the user must configure the 10FID output using register 1Ah of the host interface (see <a href="#">Section 3.8.1 on page 67</a>).</p> <p>For applications involving audio, this signal may be used in place of the AFS signal if the format selected is appropriate for a 10 field AFS repetition rate, and the desired phase relationship of audio to video clock phasing coincides with the desired film frame cadence.</p> <p>The default polarity of this signal may be inverted by programming the Polarity register at address 56h of the host interface (see <a href="#">Section 3.12.3 on page 79</a>).</p> <p>Please see <a href="#">Section 3.8.1 on page 67</a> for more detail on the 10FID output signal.</p>	TIMING_OUT_7

**Table 1-3: Output Timing Signals (Continued)**

Signal Name	Description	Default Output Pin
Display Enable	<p>The Display Enable (DE) signal is used to indicate the display enable for graphic display interfaces.</p> <p>This signal will be HIGH (default polarity) whenever pixel information is to be displayed on the display device (i.e. whenever both H Blanking and V Blanking are in the active video state)</p> <p>The width and timing of this signal will be determined by the timing parameters of the selected video standard (see <a href="#">Table 1-2</a>), or according to custom timing parameters programmed in the host interface (see <a href="#">Section 3.10 on page 74</a>).</p> <p>The default polarity of this signal may be inverted by programming the Polarity register at address 56h of the host interface (see <a href="#">Section 3.12.3 on page 79</a>).</p>	TIMING_OUT_8
Audio Frame Sync (GS4911B only)	<p>The Audio Frame Sync (AFS) signal is HIGH (default polarity) for the duration of the first line of the n<sup>th</sup> video frame to indicate that the ACLK dividers are reset at the start of line 1 of that frame. It is defined according to the frame rate of the video format and the selected audio sample rate programmed via the VID_STD[5:0] and ASR_SEL[2:0] pins or the host interface.</p> <p>For example, if the video format is based on a 59.94Hz frame rate and the audio sample rate clock is 48kHz, then n=5, and the AFS signal will be identical to the 10FID signal.</p> <p>By default, the AFS signal is reset by the 10 Field Identification (10FID) reference input. This feature may be disabled using the Audio_Control register at address 31h of the host interface (see <a href="#">Section 3.12.3 on page 79</a>). The AFS signal may also be reset using register 1Ah of the host interface. With no reference, the frame divide by “n” controlling the AFS signal will free-run at an arbitrary phase.</p> <p>The default polarity of this signal may be inverted by programming the Polarity register at address 56h of the host interface (see <a href="#">Section 3.12.3</a>).</p> <p>Please see <a href="#">Section 3.8.2 on page 68</a> for more detail on the AFS output signal.</p>	–
USER_1~4	<p>The GS4911B/GS4910B offers four user programmable output signals. Each USER signal is controlled by four timing registers and a polarity select bit. The timing registers define the start and stop times in H pixels and V lines and begin at address 57h of the host interface (see <a href="#">Section 3.12.3 on page 79</a>).</p> <p>Each user signal is individually programmable and the polarity, position, and width of each output may be defined with respect to the H, V, and F output timings of the device. Each output signal may be programmed in both the horizontal and vertical dimensions relative to the leading edges of H and V Sync. If desired, the pulses produced may then be combined with a logical AND, OR, or XOR function to produce a composite signal (for example, a horizontal back porch pulse during active lines only, or the active part of lines 15 through 20 for vertical information retrieval). Each output has selectable polarity.</p> <p>Please see <a href="#">Section 3.8.3 on page 69</a> for more detail on the USER_1~4 output signals.</p>	–

## 2. Electrical Characteristics

### 2.1 Absolute Maximum Ratings

Parameter	Conditions	Value/Units
Supply Voltage Core and Analog (CORE_VDD, VID_PLL_VDD, AUD_PLL_VDD, PhS_VDD, ANALOG_VDD)	–	-0.3V to +2.1V
Supply Voltage I/O (IO_VDD, XTAL_VDD)	–	-0.3V to +3.6V
Input Voltage Range (any input)	IO_VDD = +3.3V	-0.3V to +5.5V
	IO_VDD = +1.8V	-0.3V to +3.6V
Operating Temperature	–	-20°C ≤ T <sub>A</sub> ≤ 85°C
Storage Temperature	–	-50°C ≤ T <sub>STG</sub> ≤ 125°C
Soldering Temperature	–	260°C
ESD protection on all pins	–	1 kV

### 2.2 DC Electrical Characteristics

**Table 2-1: DC Electrical Characteristics**

V<sub>DD</sub> = 1.8V, T<sub>A</sub> = 0°C to 70°C, unless otherwise specified.

Parameter	Symbol	Condition	Min	Typ	Max	Units	Notes
<b>System</b>							
Operating Temperature Range	T <sub>A</sub>	–	0	25	70	°C	1
Core power supply voltage	CORE_VDD	–	1.71	1.8	1.89	V	–
Digital I/O Buffer Power Supply Voltage	IO_VDD	1.8V Operation	1.71	1.8	1.89	V	–
	IO_VDD	3.3V Operation	3.135	3.3	3.465	V	–
Video PLL Power Supply Voltage	VID_PLL_VDD	–	1.71	1.8	1.89	V	–
Audio PLL Power Supply Voltage (GS4911B only)	AUD_PLL_VDD	–	1.71	1.8	1.89	V	–
Analog Power Supply Voltage	ANALOG_VDD	–	1.71	1.8	1.89	V	–
Crystal Buffer Power Supply Voltage	XTAL_VDD	1.8V Operation	1.71	1.8	1.89	V	–
	XTAL_VDD	3.3V Operation	3.135	3.3	3.465	V	–
Video Clock Phase Shift Supply Voltage	PhS_VDD	–	1.71	1.8	1.89	V	–

**Table 2-1: DC Electrical Characteristics (Continued)**
 $V_{DD} = 1.8V$ ,  $T_A = 0^{\circ}C$  to  $70^{\circ}C$ , unless otherwise specified.

Parameter	Symbol	Condition	Min	Typ	Max	Units	Notes
System Power	$P_D$	GS4911B CORE_VDD = Max IO_VDD = Max T = $70^{\circ}C$ unloaded, max PCLK frequency	–	–	450	mW	–
	$P_D$	GS4911B CORE_VDD = 1.8V IO_VDD = 3.3V T = $25^{\circ}C$ unloaded, PCLK = 74.25MHz	–	300	–	mW	–
	$P_D$	GS4910B CORE_VDD = Max IO_VDD = Max T = $70^{\circ}C$ unloaded, max PCLK frequency	–	–	400	mW	–
	$P_D$	GS4910B CORE_VDD = 1.8V IO_VDD = 3.3V T = $25^{\circ}C$ unloaded, PCLK = 74.25MHz	–	250	–	mW	–
<b>Digital I/O</b>							
Input Voltage, Logic LOW	$V_{IL}$	1.8V Operation	–	–	0.35 x VDD	V	–
	$V_{IL}$	3.3V Operation	–	–	0.8	V	–
Input Voltage, Logic HIGH	$V_{IH}$	1.8V Operation	0.65 x IO_VDD	–	3.6	V	–
	$V_{IH}$	3.3V Operation	2.145	–	5.25	V	–
Output Voltage, Logic LOW	$V_{OL}$	current drive = HIGH or LOW as selected	–	–	0.4	V	2
Output Voltage, Logic HIGH	$V_{OH}$	current drive = HIGH or LOW as selected	0.65 x IO_VDD	–	–	V	2
<b>Supply Pin Current Requirements</b>							
VID_PLL_VDD (1.9V)	–	–	–	–	28.50	mA	–
XTAL_VDD (3.6V)	–	–	–	–	1.71	mA	–
AUD_PLL_VDD (1.9V)	–	–	–	–	31.45	mA	–
IO_VDD (3.6V)	–	–	–	–	6.80	mA	–

**Table 2-1: DC Electrical Characteristics (Continued)**V<sub>DD</sub> = 1.8V, T<sub>A</sub> = 0°C to 70°C, unless otherwise specified.

Parameter	Symbol	Condition	Min	Typ	Max	Units	Notes
CORE_VDD (1.9V)	–	–	–	–	42.45	mA	–
LVDS/PCLK3_VDD (1.9V)	–	–	–	–	6.32	mA	–
PCLK1&2_VDD (1.9V)	–	–	–	–	22.24	mA	–
ANALOG_VDD (1.9V)	–	–	–	–	3.94	mA	–
PhS_VDD (1.9V)	–	–	–	–	11.54	mA	–
<b>Digital Output Currents</b>							
Timing Output Drive Current	–	IO_VDD = 1.8V current drive = LOW	–	5	–	mA	–
	–	IO_VDD = 3.3V current drive = LOW	–	10	–	mA	–
	–	IO_VDD = 1.8V current drive = HIGH	–	7	–	mA	–
	–	IO_VDD = 3.3V current drive = HIGH	–	14	–	mA	–
Clock Output Drive Current	–	IO_VDD = 1.8V current drive = LOW	–	5	–	mA	–
	–	IO_VDD = 3.3V current drive = LOW	–	7	–	mA	–
	–	IO_VDD = 1.8V current drive = HIGH	–	7	–	mA	–
	–	IO_VDD = 3.3V current drive = HIGH	–	14	–	mA	–
Output Voltage LVDS, Common Mode	V <sub>OCM</sub>	–	1.125	1.25	1.375	V	3
Output Voltage LVDS, Differential	V <sub>ODIFF</sub>	–	–	350	–	mV	3
LVDS High-impedance Leakage Current	–	To 1.8V or GND	–	–	1.4	uA	–

**NOTES**

1. All DC and AC electrical parameters within specification.
2. Assuming that the current being sourced or sinked is less than the Timing Output Drive Current specified.
3. Into a 100Ω termination connected between PCLK3 and PCLK3̄.



## 2.3 AC Electrical Characteristics

Table 2-2: AC Electrical Characteristics

V<sub>DD</sub> = 1.8V, T<sub>A</sub> = 0°C to 70°C, unless otherwise specified.

Parameter	Symbol	Condition	Min	Typ	Max	Units	Notes
<b>System</b>							
Reference Detection Time	–	from when the reference input is first present	–	2	4	frames	–
<b>Digital I/O</b>							
PCLK Output Frequency	–	–	3.375	–	165	MHz	–
PCLK Jitter	–	SD video standards XTAL_VDD = 3.3V	–	350	–	ps	1, 2
	–	HD & Graphics video standards XTAL_VDD = 3.3V	–	250	–	ps	1, 3
PCLK Duty Cycle	–	–	40	–	60	%	–
PCLK1 & PCLK2 Rise/Fall Times 15pF load 20% - 80%	–	IO_VDD = 1.8V current drive = LOW	–	–	1.7	ns	–
	–	IO_VDD = 3.3V current drive = LOW	–	–	1.5	ns	–
	–	IO_VDD = 1.8V current drive = HIGH	–	–	1.1	ns	–
	–	IO_VDD = 3.3V current drive = HIGH	–	–	0.9	ns	–
PCLK3 Rise/Fall Time 20% - 80%	–	100Ω differential load 10pF to ground per pin	–	–	850	ps	–
PCLK Outputs Relative Timing Skew	–	default PCLK phase delay of zero	-3	–	3	ns	4
ACLK Frequency (GS4911B only)	–	–	0.0097	–	49.152	MHz	–
ACLK Duty Cycle (GS4911B only)	–	–	40	–	60	%	5

**Table 2-2: AC Electrical Characteristics (Continued)**V<sub>DD</sub> = 1.8V, T<sub>A</sub> = 0°C to 70°C, unless otherwise specified.

Parameter	Symbol	Condition	Min	Typ	Max	Units	Notes
ACLK1-3 Rise/Fall Times 15pF load 20% - 80% (GS4911B only)	–	IO_VDD = 1.8V current drive = LOW	–	–	3.0	ns	–
	–	IO_VDD = 3.3V current drive = LOW	–	–	1.5	ns	–
	–	IO_VDD = 1.8V current drive = HIGH	–	–	2.5	ns	–
	–	IO_VDD = 3.3V current drive = HIGH	–	–	1.4	ns	–
ACLK Outputs Relative Timing Skew (GS4911B only)	–	–	-3	–	3	ns	4
Digital Timing Output Delay Time	t <sub>OD</sub>	–	–	–	4.3	ns	6
Digital Timing Output Hold Time	t <sub>OH</sub>	–	1	–	–	ns	6
Digital Timing Output Rise/Fall Times 15pF load 20% - 80%	–	IO_VDD = 1.8V current drive = LOW	–	–	3.0	ns	–
	–	IO_VDD = 3.3V current drive = LOW	–	–	1.5	ns	–
	–	IO_VDD = 1.8V current drive = HIGH	–	–	2.5	ns	–
	–	IO_VDD = 3.3V current drive = HIGH	–	–	1.4	ns	–
<b>GSPI</b>							
GSPI Input Clock Frequency	f <sub>GSPI</sub>	–	–	–	10.0	MHz	7
GSPI Clock Duty Cycle	DC <sub>GSPI</sub>	–	40	–	60	%	7
GSPI Input Setup Time	t <sub>3 in</sub> Figure 3-18	–	1.5	–	–	ns	7

**Table 2-2: AC Electrical Characteristics (Continued)**

$V_{DD} = 1.8V$ ,  $T_A = 0^{\circ}C$  to  $70^{\circ}C$ , unless otherwise specified.

Parameter	Symbol	Condition	Min	Typ	Max	Units	Notes
GSPI Input Hold Time	$t_{g\ in}$ Figure 3-18	–	1.5	–	–	ns	7

**NOTES**

1. The video output clock may be directly connected to Gennum's GS1532 or GS1531 serializer for a SMPTE-compliant SDI or HD-SDI output with output jitter below 0.2UI, when the serializer is configured for a loop bandwidth of 100KHz.
2. All SD standards EXCEPT VID\_STD[5:0] = 1 (450ps typ.) and VID\_STD[5:0] = 5 or 6 (500ps typ.)
3. All HD and Graphics standards EXCEPT VID\_STD[5:0] = 22 (300ps typ.) and VID\_STD[5:0] = 41-43 (400ps typ.)
4. Timings from any CLK output to any other CLK output.
5. If  $f_s=96kHz$  and ACLK is configured to output a clock signal at 192fs or 384fs, a 512fs clock will typically have a 33% duty cycle distortion. See Section 3.7.2 on page 63.
6. With PCLK phasing delay set to nominal (zero offset), each increment of the clock phasing adjustment decreases output hold time and delay time by a nominal 700ps. The times  $t_{OD}$  and  $t_{OH}$  are defined in Figure 2-1.
7. For detailed GSPI timing parameters, please refer to Table 3-12.

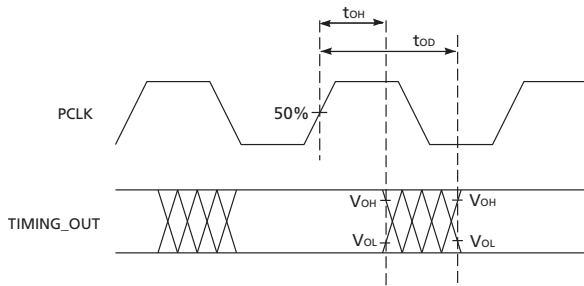

Figure 2-1: PCLK to TIMING\_OUT Signal Output Timing

Table 2-3: Suggested External Crystal Specification

27.000000 MHz
AT Cut
Nominal Dissipation = 50 $\mu$ W
Frequency accuracy at 25°C = +/- 10ppm
Frequency variation 0-70°C = +/- 10ppm
ASR = 50 +/- 20 $\Omega$

NOTE: The user may select an appropriate crystal accuracy for their application. If the device is operating in Free Run mode, the output clock and timing signals will have the same accuracy as the crystal. However, if operating in Genlock mode, all output signals are based on the input reference, and therefore a less accurate crystal may be sufficient. See [Section 3.2](#) on [page 37](#).

# 3. Detailed Description

## 3.1 Functional Overview

The GS4911B/GS4910B is a highly flexible, digitally controlled clock synthesis circuit and timing generator with genlock capability.

The device has two main modes of operation: Genlock mode and Free Run mode. In Genlock mode, the video clock and timing outputs, will be frequency and phase locked to the detected reference input signal. In Free Run mode, the occurrence of all frequencies is based on a 27MHz external crystal reference.

The GS4911B/GS4910B will recognize input reference signals conforming to 36 different video standards and 16 different graphic formats. It supports cross-locking, allowing the output to be genlocked to an incoming reference that is different from the output video standard selected.

When the device is in Genlock mode and the input reference is removed, the GS4911B/GS4910B will enter Freeze mode. In this mode, the output clock and timing signals will maintain their previously genlocked phase and frequency to within +/- 2ppm.

The user may select to output one of 8 different video sample clock rates or 13 different graphic display clock rates, or may program any clock frequency between 13.5MHz and 165MHz. The chosen clock frequency may be further internally divided, and is available on two video clock outputs and one LVDS video clock output pair. The video clocks may also be individually phase delayed with respect to the timing outputs for clock skew control.

Eight user-selectable timing outputs are provided that can automatically produce the following timing signals for 35 different video formats and 13 different graphics formats: HSync, Hblanking, VSync, Vblanking, F sync, F digital, AFS (GS4911B only), DE, and 10FID. Alternatively, custom output timing signals may be programmed in the host interface.

In addition, the GS4911B provides three audio sample clock outputs that can produce audio clocks up to 512fs with fs ranging from 9.7kHz to 96kHz. Audio to video phasing is accomplished by either an external 10FID input reference, a 10FID signal specified via internal registers, or a user-programmed audio frame sequence.

## 3.2 Modes of Operation

The GS4911B/GS4910B will operate in either Genlock mode or Free Run mode depending on the setting of the  $\overline{\text{GENLOCK}}$  pin. These two modes are described in [Section 3.2.1 on page 38](#) and [Section 3.2.2 on page 41](#) respectively.

If desired, the external  $\overline{\text{GENLOCK}}$  pin may be ignored by setting bit 5 of the Genlock\_Control register (address 16h) so that genlock can instead be controlled via the host interface (see [Section 3.12.3 on page 79](#)). Although the external  $\overline{\text{GENLOCK}}$  pin will be ignored in this case, it should not be left floating.

## 3.2.1 Genlock Mode

When the application layer sets the  $\overline{\text{GENLOCK}}$  pin LOW and the device has successfully genlocked the outputs to the input reference, the GS4911B/GS4910B will enter Genlock mode. In this mode, all clock and timing generator outputs will be frequency and phase locked to the detected input reference signal. The PCLK outputs will be locked to the H reference.

When in Genlock mode, the output clock and timing signals are generated using the applied reference signal. The 27MHz crystal reference is necessary for operation; however, neither crystal accuracy nor changes in crystal frequency (due to a shift in operating temperature) will affect the output signals. For example, the output signals will be generated with the same accuracy whether the 27MHz reference crystal has an accuracy of 10ppm or 100ppm.

The GS4911B/GS4910B supports cross-locking, allowing the outputs to be genlocked to an incoming reference that is different from the output video standard selected (see [Section 3.6 on page 50](#)).

**NOTE:** The user must apply a reference to the input of the device prior to setting  $\overline{\text{GENLOCK}} = \text{LOW}$ . If the  $\overline{\text{GENLOCK}}$  pin is set LOW and no reference signal is present, the generated clock and timing outputs of the device may correspond to the internal default settings of the chip until a reference is applied.

### 3.2.1.1 Genlock Timing Offset

By default, the phase of the clock and timing out signals is genlocked to the input reference signal. These output signals may be phase adjusted with respect to the input reference by programming the host interface (see [Section 3.12.3 on page 79](#)). Offsets are separately programmable in terms of clock phase, horizontal phase, and vertical phase (i.e. fractions of a pixel, pixels, and lines).

Genlock timing offsets can be used to co-time the output of a piece of equipment containing the GS4911B/GS4910B with the outputs of other equipment at different locations. The signal leaving the piece of equipment containing the GS4911B/GS4910B may pass through processing equipment with significant fixed delays before arriving at the switcher. These delays may include video line delays or even field delays. To compensate for these delays, genlock timing offsets allow the user to back-time the output of the equipment relative to the input reference.

Using the host interface, the following registers may be programmed once the device is stably locked:

- **Clock\_Phase\_Offset (1Dh)** - with a range of zero to one clock pulse in increments of between 1/64 and 1/512 of a clock period (depending on the PCLK frequency). The increments will be between 100ps and 200ps. All clock and timing output signals will be delayed by the clock phase offset programmed in this register.
- **H\_Offset (1Bh)** - the difference between the reference HSYNC signal and the output H Sync and/or H Blanking signal in clock pulses, with a control range of zero to +1 line. All timing output signals will be delayed by the horizontal offset programmed in this register.

- V\_Offset (1Ch) - the difference between the reference VSYNC signal and the output V Sync and/or V Blanking in lines, with a control range of zero to +1 frame. All line-based timing output signals will be delayed by the vertical offset programmed in this register.

The encoding scheme for the Clock\_Phase\_Offset register (1Dh) is shown in Table 3-1. The offset programmed will be in the positive direction. Note that the step size will depend on the frequency of the output video clock.

NOTE: If VID\_STD[5:0] = 63 and the reference format is changed, care must be taken to ensure that the Clock\_Phase\_Offset register is correctly programmed for the new output format *before* the reference is applied.

**Table 3-1: Clock\_Phase\_Offset[15:0] Encoding Scheme**

VID_STD[5:0] Setting	Output Video Clock Frequency	Step Size (Fraction of a PCLK)	Maximum Number of Steps	Bits Required to Set the Number of Steps	Clock_Phase_Offset [15:0] Settings
1	$f_{PCLK} \leq 20\text{MHz}$	$\frac{1}{512}$	511	$b_8b_7b_6b_5b_4b_3b_2b_1b_0$	$\overline{b}_8000001b_8b_7b_6b_5b_4b_3b_2b_1b_0$
3-6, 39-42	$20\text{MHz} < f_{PCLK} \leq 40\text{MHz}$	$\frac{1}{256}$	255	$b_7b_6b_5b_4b_3b_2b_1b_0$	$\overline{b}_7000010b_7b_6b_5b_40b_3b_2b_1b_0$
7-20, 25-38, 43-46	$40\text{MHz} < f_{PCLK} \leq 80\text{MHz}$	$\frac{1}{128}$	127	$b_6b_5b_4b_3b_2b_1b_0$	$\overline{b}_6000100b_6b_5b_400b_3b_2b_1b_0$
21-23, 47-51	$f_{PCLK} > 80\text{MHz}$	$\frac{1}{64}$	63	$b_5b_4b_3b_2b_1b_0$	$\overline{b}_5001000b_5b_4000b_3b_2b_1b_0$

Note: Program Clock\_Phase\_Offset = 0000 0000 0000 0000b to achieve a zero clock phase offset.

The value programmed in the H\_Offset register (1Bh) must not exceed the maximum number of clock periods per line of the outgoing video standard. Similarly, the value programmed in the V\_Offset register (1Ch) must not exceed the maximum number of lines per frame of the outgoing standard. Both horizontal and vertical offsets will be in the positive direction. Negative offsets (advances) are achieved by programming a value in the appropriate register equal to the maximum allowable offset minus the desired advance.

NOTES:

1. The device will delay all output timing signals by 2 PCLKs relative to the input HSYNC reference. This will occur even when the H\_Offset register is not programmed. The user may compensate for this delay by subtracting 2 PCLK cycles from the desired horizontal offset before loading the value into the host interface.

- For both sync and blanking-based input references, the device will advance all line-based output timing signals by 1 line relative to the input VSYNC reference for all output standards except VID\_STD[5:0] = 4, 6, and 8. This will occur even when the V\_Offset register is not programmed. The user may compensate for this advance by adding 1 line to the desired vertical offset before loading this value into the register.
- When locking the “f/1.001” HD output standards to the 525-line SD input reference standards, or vice versa, the device will delay all line-based output timing signals by ΔVSync lines relative to the input VSYNC reference. This will occur even when the V\_Offset register is not programmed. The user may compensate for this delay by subtracting ΔVSync lines from the desired vertical offset before loading this value into the register.

The value ΔVSync is given by the equation:

$$\Delta VSync = HSYNC\_IN\_Period + \Delta VSYNC\_HSYNC - (2 \times HSync\_OUT\_Period)$$

where:

HSYNC\_IN\_Period = the period of the H reference pulse

ΔVSYNC\_HSYNC = the time difference between the leading edges of the applied V and H reference pulses

Hsync\_OUT\_Period = the period of the generated H Sync output

See Figure 3-1. H\_Feedback\_Divide represents the numerator of the ratio of the output clock frequency to the frequency of the H reference pulse. It is calculated as described in Section 3.6.2.1 on page 54.

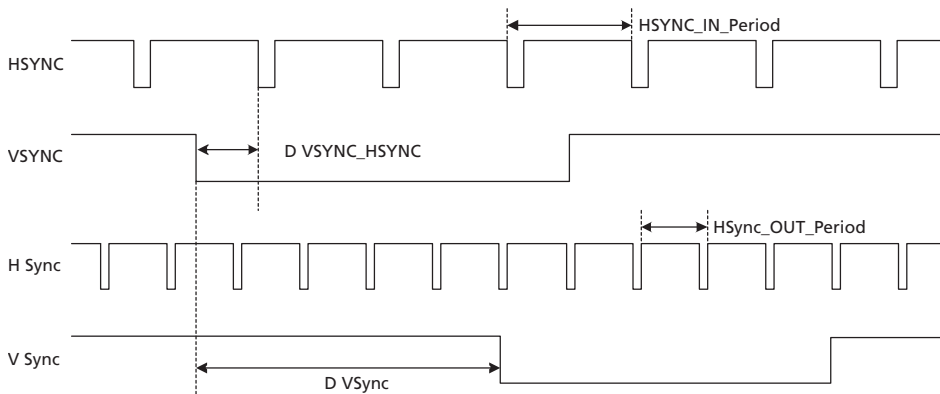

Figure 3-1: HD-SD Calculation



4. For sync-based input references, the device will advance all line-based output timing signals by 1 line if the value programmed in the H\_Offset register is greater than 20. The user may compensate for this advance by adding 1 line to the desired vertical offset before loading this value into the register. In addition, the internal V\_lock and F\_lock signals reported in bits 3 and 4 of register 16h will be LOW when H\_Offset = 20 only, although the device will remain genlocked. The user may choose to mask these lock signals such that the device will continue to report genlock under this condition.
5. For blanking-based input references, the device will advance all line-based output timing signals by 1 line if the value programmed in the H\_Offset register is greater than the number of output video clock cycles from the start of H Sync to the end of active video (Hsync\_to\_EAV) + 20. The value of Hsync\_to\_EAV is reported in register 51h and changes according to the output VID\_STD selected. The user may compensate for this advance by adding 1 line to the desired vertical offset before loading this value into the register. In addition, the internal V\_lock and F\_lock signals reported in bits 3 and 4 of register 16h will be LOW when H\_Offset = Hsync\_to\_EAV + 20 only, although the device will remain genlocked. The user may choose to mask these lock signals such that the device will continue to report genlock under this condition.
6. The offsets that occur as described in notes 1-5 are independent of one another and must be accounted for as such.

### 3.2.1.2 Freeze Mode

When the device is in Genlock mode and the input reference is removed, the GS4911B/GS4910B will enter Freeze mode. The behaviour of the device during loss and re-acquisition of an input reference signal is described in [Section 3.5.3 on page 47](#).

In Freeze mode, the frequency of the output clock and timing signals will be maintained to within +/- 2ppm. This assumes a loop bandwidth of 10Hz. Also, if the frequency of the 27MHz reference crystal shifts while in Freeze mode, the frequency of the output clock and timing signals will shift as well.

### 3.2.2 Free Run Mode

The GS4911B/GS4910B will enter Free Run mode when the  $\overline{\text{GENLOCK}}$  pin is set HIGH by the application layer. In this mode, the occurrence of all frequencies is based on the external 27MHz reference input. Therefore, the frequency of the output clock and timing signals will have the same accuracy as the crystal reference.

If operating in Free Run mode, using a more accurate crystal (e.g. 10ppm) ensures more accurate clock and timing signals are generated.

NOTE: In Free Run mode, the audio clocks of the GS4911B will remain genlocked to the video clock.

Figure 3-2 summarizes the differences in output accuracy in each mode of operation. Assuming a crystal reference of +/-100ppm, in Free Run mode the frequency of the output clock and timing signals will be as accurate as the crystal. In Genlock mode the frequency will be as accurate as the input reference regardless of the crystal accuracy. In Freeze mode, the frequency of the output clock and timing signals will be maintained to within +/- 2ppm.

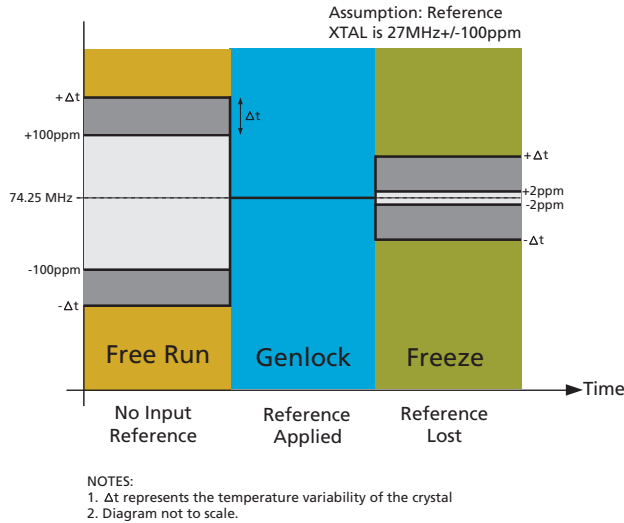

Figure 3-2: Output Accuracy and Modes of Operation

### 3.3 Output Timing Format Selection

At device power-up (described in Section 3.14 on page 111), the application layer should immediately set the external VID\_STD[5:0] and ASR\_SEL[2:0] pins. The VID\_STD[5:0] pins are used to select a pre-programmed output video format, or to indicate that custom timing parameters will be programmed in the host interface. The ASR\_SEL[2:0] pins are only available on the GS4911B, and are used to select the fundamental audio frequency or to turn off audio clock generation.

The output timing formats selectable by the user via the VID\_STD[5:0] pins are listed in Section 1.4 on page 20. Table 3-7 in Section 3.7.2 on page 63 lists the audio sample rates available via the ASR\_SEL[2:0] pins.

If the user sets VID\_STD[5:0] = 1-51 on power-up, the device will first check the status of the  $\overline{\text{GENLOCK}}$  pin. If  $\overline{\text{GENLOCK}}$  is set LOW and a valid reference has been applied to the inputs, the device will output the selected video standard while attempting to genlock. However, if a reference signal has not been applied and  $\overline{\text{GENLOCK}} = \text{LOW}$ , the initial clock and timing outputs may be determined by the internal default settings of the chip. If  $\overline{\text{GENLOCK}}$  is set HIGH, the device will immediately enter Free Run mode and will correctly output the selected video standard.

If the user sets VID\_STD[5:0] = 62 on power-up, the device will be configured to generate custom output timing signals. The initial output timing signals will be equal to the internal default timing of the chip until the user programs registers 4Eh to 55h of the host interface (see Section 3.10 on page 74). Additionally, the output video clock will run at a

frequency determined by the internal default settings of the chip until the user modifies it via registers 20h to 23h (see [Section 3.9.1 on page 72](#)).

If the user sets VID\_STD[5:0] = 63 on power-up, the device will wait until a valid reference has been applied, at which time it will output the same video format as the input reference and enter Genlock mode if  $\overline{\text{GENLOCK}} = \text{LOW}$ .

When operating in Free Run or Genlock mode, the GS4911B/GS4910B will continuously monitor the settings of the VID\_STD[5:0] and ASR\_SEL[2:0] pins. If the user wishes to change the format of the output clocks and timing signals, these pins may be reconfigured at any time, although it is recommended that the device be reset when changing output video standards.

### 3.4 Input Reference Signals

The HSYNC, VSYNC, FSYNC, and 10FID reference signals are applied to the GS4911B/GS4910B via the designated input pins.

To operate in Genlock mode, the input reference signals must be valid and must conform to a recognized video or graphics standard (see [Section 3.5 on page 45](#)). Alternatively, if VID\_STD[5:0] = 62, the signal applied to the HSYNC input must be stable and have a period of less than 2.4ms.

In Free Run mode, no input reference is required.

[Section 3.4.1 on page 43](#) describes the HSYNC, VSYNC and FSYNC input timing. The 10FID input signal is discussed in [Section 3.4.2 on page 44](#).

#### 3.4.1 HSYNC, VSYNC, and FSYNC

##### Timing for Video Formats

The HSYNC, VSYNC, and FSYNC input reference signals may have analog timing, such as from Gennum's GS4981/82 sync separators ([Figure 3-3](#)), or may have digital timing, such as from Gennum's GS1559/60A/61 deserializers ([Figure 3-4](#)). [Section 1.4 on page 20](#) lists the 36 pre-programmed video timing formats recognized by the GS4911B/GS4910B.

If the input reference format does not include an F sync signal, the FSYNC pin should be held LOW.

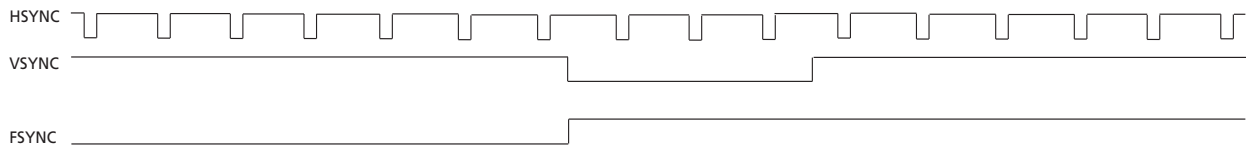

Figure 3-3: Example HSYNC, VSYNC, and FSYNC Analog Input Timing from a Sync Separator

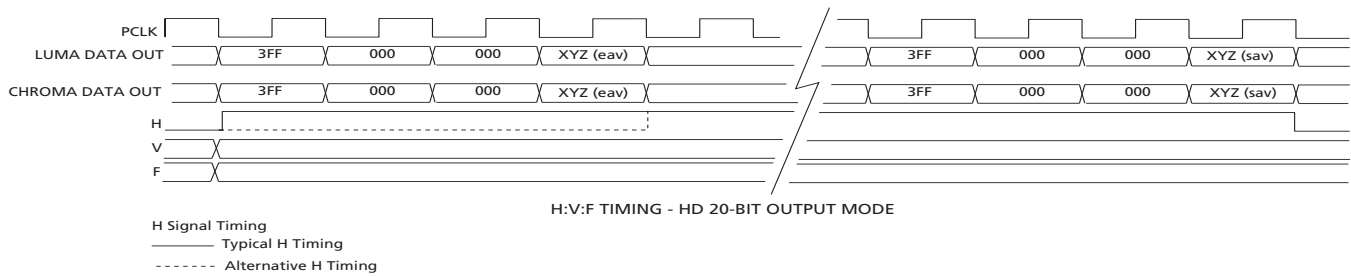

Figure 3-4: Example H Blanking, V Blanking, and F Digital Input Timing from an SDI Deserializer

### Timing for Graphics Formats

The GS4911B/GS4910B is pre-programmed to recognize the timing for 16 different graphics formats presented to the input reference pins. These graphic formats are described in [Section 1.4 on page 20](#).

The supported graphics standards are all progressive, and do not use the FSYNC signal. Therefore, FSYNC should be held LOW by the application layer. The VESA formats supported have a 0.5% frequency tolerance.

VSYNC transitions are typically co-timed with the leading edge of HSYNC. The duration and polarity of these signals for each format is listed in [Table 1-2](#).

NOTE: The user must ensure that the input HSYNC polarity for VID\_STD [5:0] = 47 and 49 – 54 be active LOW.

### 3.4.2 10FID

The 10FID input is a reset pin, which can be used to reset the divider for the 10FID output signal. In the GS4911B, the 10FID input pin will also reset the divider for the AFS output signal. This default setting may be modified using the Audio\_Control register of the host interface (see [Section 3.12.3 on page 79](#)).

The GS4911B will reset the phase of the audio clocks to the leading edge of the H Sync output on line 1 of every output frame in which the 10FID input is HIGH. This enables the user to reset the phase of the dividers when generating custom signals via the host interface (see [Section 3.7.2.1 on page 65](#)).

If the input reference format does not include a 10 Field ID signal, the external 10FID input pin should be held LOW.

The timing of the 10FID input signal is shown in [Figure 3-5](#).

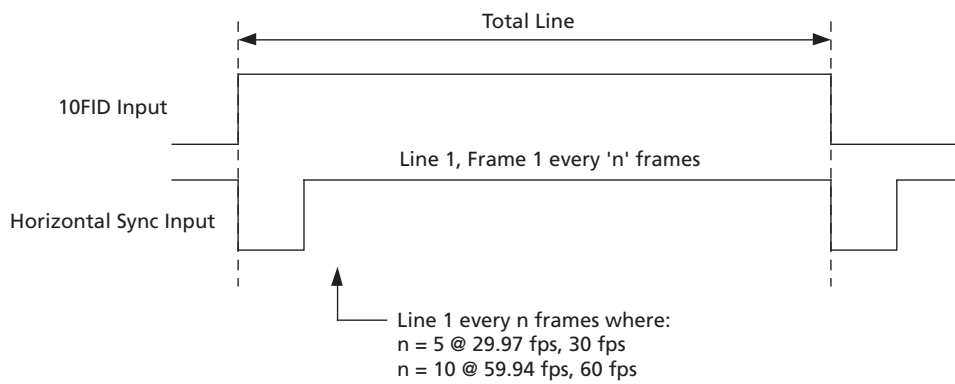

Figure 3-5: 10FID Input Timing

### 3.4.3 Automatic Polarity Recognition

To accommodate any standards that employ the polarity of the H and V sync signals to indicate the format of the display, the GS4911B/GS4910B will recognize H and V sync polarity and automatically synchronize to the leading edge.

The polarities of the HSYNC and VSYNC signals are reported in bits 3 and 4 of the Video\_Status register. Additionally, bit 2 of this register reports the detection of either analog or digital input timing. See [Section 3.12.3 on page 79](#) for detailed register descriptions.

## 3.5 Reference Format Detector

The reference format detector checks the validity and analyzes the format of the input reference signal. It is designed to accurately differentiate between 59.94 and 60Hz frame rates.

### 3.5.1 Horizontal and Vertical Timing Characteristic Measurements

When a reference signal is applied to the designated input pins, the GS4911B/GS4910B will analyse the signal and report the following in registers 0Ah to 0Eh of the host interface:

- the number of 27MHz clock pulses between leading edges of the H input reference signal (H\_Period register)
- the number of 27MHz clock pulses in 16 horizontal periods (H\_16\_Period register)
- the number of H reference pulses between leading edges of the V input reference signal (V\_Lines register)
- the number of H reference pulses in two vertical periods (V\_2\_Lines register)
- the number of H reference pulses in one F period (F\_Lines register)

These parameters may be read via the host interface and are used by the device to determine reference signal validity.

## 3.5.2 Input Reference Validity

Before the device attempts to operate in Genlock mode, the input signals applied to HSYNC and VSYNC must be valid and must conform to one of the 36 recognized video standards or 16 recognized graphics standards described in [Section 1.4 on page 20](#). Alternatively, if VID\_STD[5:0] = 62, the device may be manually programmed to genlock to a reference that is neither valid nor recognized (see [Section 3.10.1 on page 75](#)).

For an input reference signal to be considered valid, the periodicity of HSYNC must be between 9 $\mu$ s and 70 $\mu$ s, and the periodicity of VSYNC must be between 8ms and 50ms. The FSYNC signal is not essential for validity. For output video standards other than VID\_STD[5:0] = 62, the REF\_LOST pin will be set LOW once the input reference signal is considered valid.

If the input signal is valid, the device then compares the timing parameters of the input reference signal to each of the 36 video and 16 graphics standards listed in [Table 1-2](#), and determines if the input reference is one of the recognized standards. If it is, the VID\_STD[5:0] value for the format is written to the Input\_Standard register at address 0Fh of the host interface. If the input signal is invalid, or if the reference format is unrecognized, 00h is programmed in this register.

Once a reference signal is valid and recognized by the device, VSYNC and FSYNC will no longer be monitored. Loss of signal on these pins will not affect the operation of the device.

If VID\_STD[5:0] is not set to 62 and the REF\_LOST pin is HIGH, or if the input signal is valid, but unrecognized as one of the 36 video or 16 graphics formats, the  $\overline{\text{GENLOCK}}$  pin should not be set LOW.

If VID\_STD[5:0] = 62, the REF\_LOST output will reflect the presence of a stable signal with a period of less than 2.4ms on the HSYNC input pin. This allows the user to program the device to lock to a single input reference only

The REF\_LOST output pin may also be read via bit 0 of the Genlock\_Status register (see [Section 3.12.3 on page 79](#)).

### 3.5.2.1 Ambiguous Standard Selection

There are some standards with identical H, V, and F timing parameters, such that the GS4911B/GS4910B's reference format detector cannot distinguish between them. [Table 3-2](#) groups standards with shared H, V, and F periods. Using the Amb\_Std\_Sel register at address 10h of the host interface, the user may select their choice of standard to be identified with a particular set of measurements. For example, to have 1716 clocks of 27MHz per line with 525 lines per frame identified as 4fsc 525, program Amb\_Std\_Sel[10:0] = XXX10XXXXXX, where 'X' signifies 'don't care'.

**Table 3-2: Ambiguous Standard Identification**

Number	Standard	H (27MHz Clocks)	16_H (27MHz Clocks)	V (lines)	F (lines)	Amb_Std_Sel[10:0]
1	1920x1080/60/2:1 interlace	800	12800	562.5	1125	X X X X X X X X X 0 0
	1920x1080/30/PsF	800	12800	562.5	1125	X X X X X X X X X 0 1
	1920x1035/60/2:1 interlace	800	12800	562.5	1125	X X X X X X X X X 1 0
2	1920x1080/59.94/2:1 interlace	800.8	12813	562.5	1125	X X X X X X X 0 0 X X
	1920x1080/29.97/PsF	800.8	12813	562.5	1125	X X X X X X X 0 1 X X
	1920x1035/59.94/2:1 interlace	800.8	12813	562.5	1125	X X X X X X X 1 0 X X
3	1920x1080/50/2:1 interlace	960	15360	562.4	1125	X X X X X 0 0 X X X X
	1920x1080/25/PsF	960	15360	562.4	1125	X X X X X 0 1 X X X X
4	601 525 / 2:1 interlace	1716	27456	262.5	525	X X X 0 0 X X X X X X
	720x486/59.94/2:1 interlace	1716	27456	262.5	525	X X X 0 1 X X X X X X
	4fsc 525 / 2:1 interlace	1716	27456	262.5	525	X X X 1 0 X X X X X X
	601 - 18MHz 525/2:1 interlace	1716	27456	262.5	525	X X X 1 1 X X X X X X
5	601 625 / 2:1 interlace	1728	27648	312.5	625	X 0 0 X X X X X X X X
	720x576/50/2:1 interlace	1728	27648	312.5	625	X 0 1 X X X X X X X X
	Composite PAL 625/2:1/25	1728	27648	312.5	625	X 1 0 X X X X X X X X
	601 - 18MHz 625/2:1 interlace	1728	27648	312.5	625	X 1 1 X X X X X X X X
6	640 x 480 VGA @ 60Hz	857.14	13714	525	525	0 X X X X X X X X X X
	720x483/59.94/1:1 progressive	858	13728	525	525	1 X X X X X X X X X X

NOTE: 'X' signifies 'don't care.' The X bit will be ignored when determining which standard to select in each of the 6 groups above.

### 3.5.3 Behaviour on Loss and Re-acquisition of the Reference Signal

By default, the GS4911B/GS4910B will ignore one missing H pulse on the HSYNC pin and will continue to operate in Genlock mode (although the LOCK\_LOST pin will temporarily be set HIGH). This behaviour is controlled by the Run\_Window bits of register address 24h.

If there are two consecutive missing H pulses on the HSYNC input pin, the REF\_LOST and LOCK\_LOST pins will both go HIGH and the device will enter Freeze mode. An internal flywheel ensures the selected output clock and timing signals maintain their previous phase and frequency and continue to operate without glitches.

The VSYNC and FSYNC signals are not monitored in Genlock mode; loss of signal on these pins will not affect the operation of the device.

NOTE 1: If the input reference is removed and re-applied, all line-based timing outputs will be inaccurate for up to one frame for all output standards.

NOTE 2: When locking the “ $f/1.001$ ” HD output standards to the SD input reference standards 3, 5, 7, or 9, or vice versa, there may be a random phase difference between the input VSYNC and output V Sync signals occurring each time the input reference is removed and re-applied. This will affect all line-based timing outputs. For cases where the user must manually video genlock the device, the problem will occur whenever the value programmed for H\_Reference\_Divide (registers 2B-2A<sub>H</sub>) is greater than 1. The user may reset the line-based counters after the reference is re-applied without disrupting the pixel or audio clocks by toggling bit 15 of register address 83h in the host interface. This will cause the input VSYNC and line-based timing output signals to take on their default timing relationship, as described in Note 3 of [Section 3.2.1.1 on page 38](#).

### Re-acquisition of the Same Reference

Upon re-application of the reference signal, the device checks whether the reference has drifted more than  $\pm 2\mu\text{s}$  from its expected location by comparing the current relative position of the H pulses with the previous position, over a 16-line interval. If the reference returns with the H pulses in the expected location  $\pm 2\mu\text{s}$ , the PLL will drift lock and the clock generator will continue to operate without a glitch. The REF\_LOST and LOCK\_LOST pins will be set back LOW.

If the reference returns with the H pulses outside the  $\pm 2\mu\text{s}$  window, the device will crash lock the output timing to the new input phase. The principles of crash lock and drift lock are described in [Section 3.6.3 on page 58](#).

NOTE: To resume proper genlock operation upon re-application of the reference signal, the user must implement the following register manipulation every time the reference is removed and re-applied:

1. Read the value contained in register address 24h
2. Clear the Run\_Window bits [2:0] of register 24h
3. Re-write the value read in step 1 to register address 24h.

This procedure will force the device to lock to the reference as described above, but will maintain the flywheeling capability of the GS4911B/GS4910B should a single missing H pulse occur in the genlocked state.

To avoid the above procedure, the user may choose to clear the Run\_Window bits [2:0] of register address 24h upon power-up or reset. However, this will disable the flywheeling feature of the device that allows it to maintain genlock through one missing input H pulse.



## Acquisition of a New Reference

When a new reference is applied, the device continues to operate in Freeze mode while the reference format detector checks for validity as described in Section 3.5.2 on page 46. Once validity is detected, the REF\_LOST pin is set LOW.

Assuming  $\overline{\text{GENLOCK}}$  is LOW, the device will then attempt to genlock the selected output clock and timing signals to the new input reference. If the output can be automatically genlocked to the new input reference, LOCK\_LOST will go LOW and the device will re-enter Genlock mode. Otherwise, the LOCK\_LOST pin will remain HIGH and the device will enter Free Run mode.

If VID\_STD[5:0] = 63 when the new reference is applied, the device will send the detected timing parameters to the clock synthesis and timing generator blocks. The new output format will start being generated during the first reference V period after the reference format has been reliably established. The LOCK\_LOST pin will go LOW and the device will re-enter Genlock mode.

## 3.5.4 Allowable Frequency Drift on the Reference

By default, the frequency of the reference H pulse on HSYNC may drift from its expected value by approximately +/- 0.2% before the internal video PLL loses lock. This tolerance may be adjusted using the Max\_Ref\_Delta register at address 1Eh of the host interface.

The encoding scheme is shown in Table 3-3. The default value of the register is Bh.

NOTE: Regardless of the setting of this register, the device will always differentiate between 59.94Hz and 60Hz reference standards.

Table 3-3: Max\_Ref\_Delta Encoding Scheme

Register Setting	Maximum Allowable Frequency Drift	Register Setting	Maximum Allowable Frequency Drift
0h	+/- 2 <sup>-20</sup>	8h	+/- 2 <sup>-12</sup>
1h	+/- 2 <sup>-19</sup>	9h	+/- 2 <sup>-11</sup>
2h	+/- 2 <sup>-18</sup>	Ah	+/- 2 <sup>-10</sup>
3h	+/- 2 <sup>-17</sup>	Bh	+/- 2 <sup>-9</sup>
4h	+/- 2 <sup>-16</sup>	Ch	+/- 2 <sup>-8</sup>
5h	+/- 2 <sup>-15</sup>	Dh	+/- 2 <sup>-7</sup>
6h	+/- 2 <sup>-14</sup>	Eh	+/- 2 <sup>-6</sup>
7h	+/- 2 <sup>-13</sup>	Fh	+/- 2 <sup>-5</sup>

The maximum allowable frequency drift is measured as a fraction of the frequency of the reference H pulse.

## 3.6 Genlock

When both the REF\_LOST output and the  $\overline{\text{GENLOCK}}$  input are LOW, the device will attempt to genlock the output clock and timing signals to the input reference.

NOTE: The user must apply a reference to the input of the device prior to setting  $\overline{\text{GENLOCK}} = \text{LOW}$ . If the  $\overline{\text{GENLOCK}}$  pin is set LOW and no reference signal is present, the generated clock and timing outputs of the device may correspond to the internal default settings of the chip until a reference is applied.

The device will first attempt to automatically genlock the output to the input reference. This automatic locking process is described in [Section 3.6.1 on page 50](#). If the output format selected is such that it is not commonly genlocked to the input reference, the GS4911B/GS4910B will not automatically lock. In this case, the user may program designated registers to manually allow locking to occur. The manual locking process is described in [Section 3.6.2 on page 54](#).

The user may disable one or more of the recognized input standards from being used to genlock the output by setting the Reference\_Standard\_Disable register located at address 11h - 14h of the host interface. If a reference is applied that is disabled in the Reference\_Standard\_Disable register, both the automatic and manual locking process will fail when the application layer sets  $\overline{\text{GENLOCK}} = \text{LOW}$ .

NOTE: If the device is already genlocked to an input reference and the applied standard is subsequently disabled in the Reference\_Standard\_Disable register, the device will remain locked.

### 3.6.1 Automatic Locking Process

The behaviour of the device when attempting to automatically genlock will depend on the status and format of the input reference with respect to the selected output format.

#### VID\_STD[5:0] = 1 to 51:

Once reference validity is established and the reference format is recognized, the device uses an internal cross-reference genlock look-up table to determine whether the input can be used to genlock the output. A simplified version of this look-up table is shown in [Table 3-4](#). The table represents a matrix with the VID\_STD[5:0] number representation of each possible reference format along the top axis, and the VID\_STD[5:0] representation of each possible output timing format along the vertical axis. A shaded box indicates that the output format can be automatically genlocked to the input reference.

If the device determines that the output can be automatically genlocked to the input reference, it will lock the output format to the reference, adjust the output timing signals based on the genlock timing offset registers ([Section 3.2.1.1 on page 38](#)), and then set the LOCK\_LOST pin LOW.

If the device cannot automatically genlock the output to the applied reference, the LOCK\_LOST pin will be set HIGH and the device will operate in Free Run mode. In this case, the user may program designated registers to manually allow locking to occur (Section 3.6.2 on page 54).

Individual H, V, and F-locked signals can be read from the Genlock\_Status register of the host interface. Additionally, designated bits in the Genlock\_Control register may be configured to permit the genlock block to ignore invalid timing on the HSYNC, VSYNC, or FSYNC pin when determining the locked status of the device. These registers are described in Section 3.12.3 on page 79.

NOTE: When attempting to lock some output graphics standards to an input reference, the device will automatically modify the output frame rate from the VESA standard to permit cross-locking to occur. The exact change will depend on the output standard selected and the input reference detected. Standards affected by this behaviour are denoted by an 'a' or a 'b' suffix in Table 3-4.

#### **VID\_STD[5:0] = 62:**

Setting VID\_STD[5:0]=62 allows custom timing signals to be programmed in the host register (see Section 3.10 on page 74). It has the additional feature of disabling the validity check of the input reference signal.

The device will automatically attempt to genlock the custom output to the input using the same process that is used when VID\_STD[5:0] = 1 to 51. The user must manually program the internal genlock block if a custom H-based timing output signal is programmed or if a custom reference pulse is applied to HSYNC.

#### **VID\_STD[5:0] = 63:**

When VID\_STD[5:0]=63, the device will send the detected input reference timing parameters to the clock synthesis and timing generator blocks. The device will produce an output format with identical timing to the input reference. It will then lock the output format to the reference, adjust the output timing parameters based on the genlock timing offset registers (Section 3.2.1.1 on page 38), and set the LOCK\_LOST pin LOW.





## 3.6.2 Manual Locking Process

Using the host interface, the GS4911B/GS4910B may be manually programmed to genlock certain video formats and audio clocks that are not automatically genlocked by the device. The following sections discuss when the user should manually program the internal video and/or audio genlock block, and how these blocks are programmed.

### 3.6.2.1 Programming the Internal Video Genlock Block and Output Line/Frame Reset Registers

The user will be required to manually program the internal video genlock block and output line/frame reset registers during any of the following situations:

1. The pre-programmed output format and input reference cannot be automatically genlocked according to the cross-reference genlock table (Table 3-4 in Section 3.6.1 on page 50).
2. A custom video clock is programmed in the host interface (Section 3.9.1 on page 72).
3. VID\_STD[5:0] = 62 and a custom H-based timing output signal is programmed (see Section 3.10 on page 74).
4. VID\_STD[5:0] = 62 and a custom reference pulse is applied to HSYNC (see Section 3.10.1 on page 75).

### Video Genlock Block Host Registers

A simplified version of the GS4911B/GS4910B's internal video genlock block is shown in Figure 3-6.

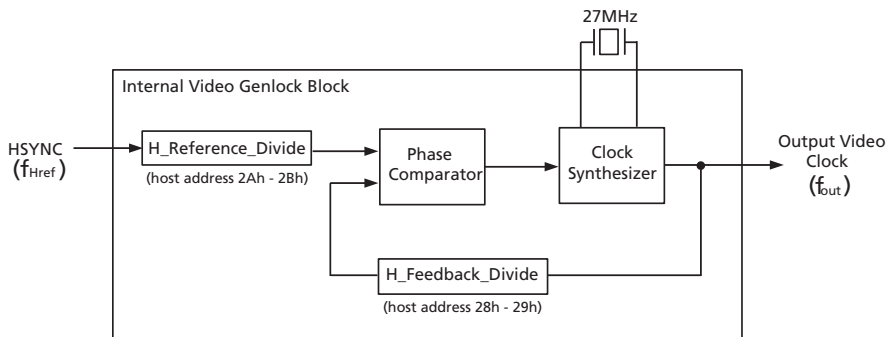

Figure 3-6: Internal Video Genlock Block

To genlock the output clock and video timing signals to the input format, the user must first lock the frequency of the output video clock ( $f_{out}$ ) to the frequency of the reference pulse on HSYNC ( $f_{Href}$ ). This is accomplished by programming the set of integers ( $H\_Feedback\_Divide$ ,  $H\_Reference\_Divide$ ) in the equation:

where:

$f_{out}$  = output video clock frequency

$f_{Href}$  = reference H pulse frequency on HSYNC

$H\_Feedback\_Divide$  = numerator of the divide ratio (host register 28h-29h)

$H\_Reference\_Divide$  = denominator of the divide ratio (host register 2Ah-2Bh)

$$\frac{H\_Feedback\_Divide}{H\_Reference\_Divide} = \frac{f_{out}}{f_{Href}}$$

Before programming H\_Feedback\_Divide and H\_Reference\_Divide, the numerator and denominator must be reduced to their lowest factors.

For example, to manually genlock an output format with a 74.25MHz video clock to a reference with a 27MHz video clock and 1716 clocks per line, the following calculations are necessary:

$$f_{Href} = \frac{27}{1716} \text{MHz}$$

$$\therefore \frac{H\_Feedback\_Divide}{H\_Reference\_Divide} = \frac{74.25 \text{MHz}}{\frac{27}{1716} \text{MHz}} = 74.25 \times \frac{1716}{27} = \frac{127413}{27} = \frac{4719}{1}$$

Therefore, program H\_Feedback\_Divide = 4719 and H\_Reference\_Divide = 1.

### Output Line/Frame Reset Host Registers

In addition to programming H\_Feedback\_Divide and H\_Reference\_Divide, the user must also define the ratio of the output frame rate to the reference frame rate. The denominator of this ratio is programmed in the Output\_FV\_Reset register at address 18h of the host interface. Before Output\_FV\_Reset is programmed, the numerator and denominator must be reduced to their lowest factors. Two examples are demonstrated below:

Example 1: the reference has a frame rate of 30Hz and the output frame rate is 50Hz:

$$\frac{Output\ Frame\ Rate}{Input\ Frame\ Rate} = \frac{50}{30} = \frac{5}{3}$$

Therefore, program Output\_FV\_Reset = 3. The numerator does not have to be programmed.

Example 2: the reference has a frame rate of 29.97Hz and the output frame rate is 50Hz:

$$\frac{Output\ Frame\ Rate}{Input\ Frame\ Rate} = \frac{50}{29.97} = \frac{1001}{600}$$

Therefore, program Output\_FV\_Reset = 600. The numerator does not have to be programmed.

Additionally, the Frame\_Divider\_Reset register (address 19h) must be configured to initialize the counter reset programmed in register 18h.

Alternatively, depending on the information available, the user may program the Output\_H\_Reset register (address 17h) instead of programming registers 18h and 19h. Output\_H\_Reset defines the denominator of the ratio of the output line frequency to the input line frequency. Before Output\_H\_Reset is programmed, the numerator and denominator must be reduced to their lowest factors.

For example, to genlock the output standard 720p/59.94 at 74.25/1.001MHz to the input standard 525i/29.97 at 27MHz:

$$\text{Input Line Frequency} = \frac{\text{Input Video Clock Frequency}}{\text{Video Clocks per Input H}} = \frac{27000000}{1716}$$

$$\text{Output Line Frequency} = \frac{\text{Output Video Clock Frequency}}{\text{Video Clocks per Output H}} = \frac{74250000}{1650} \times \frac{1000}{1001}$$

$$\therefore \frac{\text{Output Line Frequency}}{\text{Input Line Frequency}} = \frac{74250000 \times 1000 \times 1716}{27000000 \times 1001 \times 1650} = \frac{20}{7}$$

Therefore, program Output\_H\_Reset = 7. The numerator does not have to be programmed.

NOTE: Either register 17h OR registers 18h and 19h should be programmed. Programming all three registers will trigger two counter resets.

Programming OUTPUT\_FV\_RESET is preferred in all cases except where a custom reference pulse is used in VID\_STD[5:0] = 62 (see Section 3.10.1 on page 75). In this case, OUTPUT\_H\_RESET must be used.

### 3.6.2.2 Programming the Internal Audio Genlock Block (GS4911B only)

By default, the audio clocks are always genlocked to the output video clock. However, if a custom video or audio clock is programmed in the host interface (see Section 3.9 on page 72), the user must manually program the internal audio genlock block.

A simplified version of the GS4911B's internal audio genlock block is shown in Figure 3-7.

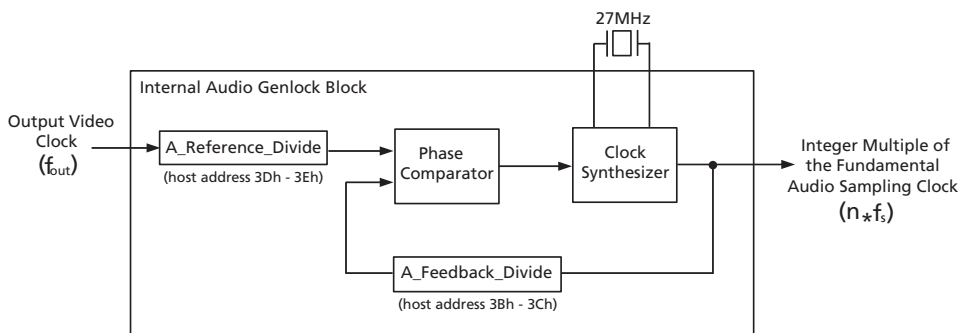

Figure 3-7: Internal Audio Genlock Block

To genlock the audio clock to the video clock, the user must lock the fundamental sampling frequency ( $f_s$ ) to the frequency of the output video clock ( $f_{out}$ ). This is



accomplished by programming the set of integers (A\_Feedback\_Divide, A\_Reference\_Divide) in the equation:

$$\frac{A\_Feedback\_Divide}{A\_Reference\_Divide} = n \times \frac{f_s}{f_{out}}$$

where:

$f_s$  = the fundamental audio sampling frequency

$f_{out}$  = output video clock frequency

A\_Feedback\_Divide = numerator of the divide ratio (host register 3Bh-3Ch)

A\_Reference\_Divide = denominator of the divide ratio (host register 3Dh-3Eh)

n = an integer constant

The integer constant, n, will depend on the fundamental audio sampling frequency. It will be one of the three values as defined in [Table 3-5](#).

**Table 3-5: Integer Constant Value**

ASR_SEL[2:0]=100b	Enable_384fs = 0	Value of constant (n)
NO	X	3072
YES	YES	1024
YES	NO	1536

**NOTES:**

1. Enable\_384fs corresponds to bit 5 of address 31h of the host interface. It is LOW by default.
2. 'X' signifies 'don't care.' This bit will be ignored when determining n.

Before programming A\_Feedback\_Divide and A\_Reference\_Divide, the numerator and denominator must be reduced to their lowest factors.

For example, to manually genlock a custom audio clock with a fundamental sampling frequency of 42kHz to a 27MHz video clock, the following calculations are necessary:  
n = 1024

$$\therefore \frac{A\_Feedback\_Divide}{A\_Reference\_Divide} = 1024 \times \frac{42000}{27000000} = \frac{43008}{27000} = \frac{1792}{1125}$$

Therefore, program A\_Feedback\_Divide = 1792 and A\_Reference\_Divide = 1125. Note that n=1024 when programming a custom audio clock (see [Section 3.9.2 on page 73](#)).

### 3.6.3 Adjustable Locking Time

The GS4911B/GS4910B offers two different locking mechanisms to allow the user to control the PLL lock time and the integrity of the output signal during the locking process. The locking process is said to take place after the application of the input reference and before the LOCK\_LOST signal is set LOW.

By default, the internal PLL will crash lock. This locking process will ensure a minimum PLL locking time; however, crash lock will cause the phase of the output clock and timing signals to jump during the locking process. The crash behaviour of the video PLL is controlled by the Crash\_Time bits of register address 24h.

Alternatively, the user may set bit 1 of register 16h HIGH to force the PLL to drift lock. Drift lock will increase the locking time of the PLL, but will maintain the signal integrity of the output clock and timing pulses during the locking process.

As discussed in [Section 3.5.3 on page 47](#), the device will normally drift lock when the reference is removed and subsequently re-applied during Genlock mode.

### 3.6.4 Adjustable Loop Bandwidth

The default loop bandwidth of the GS4911B/GS4910B's internal video PLL is 10Hz when the output video standard is the same as the input reference format. For other cross-locking combinations, the default loop bandwidth may be smaller than 1Hz or as large as 30Hz.

The user may adjust the loop bandwidth of both the video and audio PLLs to a value that depends on the input, output, and audio standards selected, as well as on the amplitude of the jitter present on the applied HSYNC signal. Increasing the loop bandwidth will result in a shorter PLL lock time, but will allow more frequency components of jitter to be passed to the outputs. Decreasing the loop bandwidth will decrease the output jitter, but will result in a longer PLL lock time.

#### 3.6.4.1 Loop Bandwidth of the Video PLL

The capacitive component of the filter controlling the video loop bandwidth is determined by the Video\_Cap\_Genlock register and the resistive component is determined by the Video\_Res\_Genlock register. These two registers are located at addresses 26h and 27h, respectively, of the host interface.

To determine the setting of Video\_Res\_Genlock and Video\_Cap\_Genlock, the following equations must be solved:

$$\text{Video\_Res\_Genlock} = \lceil 47 + \log_2(6 \times \text{BW} \times \text{JITTERIN} \times \text{H\_Feedback\_Divide}) \rceil$$

$$\text{Video\_Cap\_Genlock} \leq \text{Video\_Res\_Genlock} - 21$$

where:

BW = the desired video PLL loop bandwidth

JITTERIN = Jitter present on applied HSYNC reference signal, in seconds

H\_Feedback\_Divide = the numerator of the video PLL divide ratio

H\_Feedback\_Divide represents the numerator of the ratio of the output clock frequency to the frequency of the H reference pulse. It is calculated as described in [Section 3.6.2.1 on page 54](#).

NOTE: The bandwidth calculation represented by the above equation is only approximate. As the programmed value of Video\_Res\_Genlock becomes larger, the approximation becomes more accurate.

For example, the following steps are necessary to program a loop bandwidth of 25Hz given the following conditions: input HSYNC jitter = 3 ns, VID\_STD[5:0] = 3 and input reference format = NTSC.

1. Calculate H\_Feedback\_Divide (as defined in [Section 3.6.2.1 on page 54](#)):

$$\frac{H\_Feedback\_Divide}{H\_Reference\_Divide} \times \frac{f_{pclkout}}{f_{Hrefin}}$$

$$f_{pclkout} = 27\text{MHz}$$

$$\therefore \frac{H\_Feedback\_Divide}{H\_Reference\_Divide} = 27 \times \frac{1716}{27} = \frac{1716}{1}$$

$$f_{Hrefin} = \frac{27}{1716}\text{MHz}$$

Therefore, H\_Feedback\_Divide = 1716.

2. Calculate the value for Video\_Res\_Genlock:

$$Video\_Res\_Genlock = \left\lceil 47 + \log_2(6 \times 25 \times (3 \times 10^{-9}) \times 1716) \right\rceil = 37$$

3. Calculate the value for Video\_Cap\_Genlock:

$$Video\_Cap\_Genlock = 37 - 21 = 16$$

Therefore, program Video\_Res\_Genlock = 37 and Video\_Cap\_Genlock = 16.

NOTE: The value programmed in the Video\_Res\_Genlock register must be between 32 and 42. The value programmed in the Video\_Cap\_Genlock register must be greater than 10. These limits define the exact range of loop bandwidth adjustment available.

### 3.6.4.2 Loop Bandwidth of the Audio PLL (GS4911B only)

The capacitive component of the filter controlling the audio loop bandwidth is determined by the Audio\_Cap\_Genlock register and the resistive component is determined by the Audio\_Res\_Genlock register. These two registers are located at addresses 39h and 3Ah, respectively, of the host interface.

To determine the setting of Audio\_Res\_Genlock and Audio\_Cap\_Genlock, the following equations must be solved:

$$\mathbf{Audio\_Res\_Genlock} = \lceil 47 + \log_2(6 \times \mathbf{BW} \times \mathbf{JITTERIN} \times \mathbf{A\_Feedback\_Divide}) \rceil$$

$$\mathbf{Audio\_Cap\_Genlock} \leq \mathbf{Audio\_Res\_Genlock} - 21$$

where:

BW = the desired audio PLL loop bandwidth

JITTERIN = Jitter present on output PCLK, in seconds.

A\_Feedback\_Divide = the numerator of the audio PLL divide ratio

A\_Feedback\_Divide is calculated in the same way as demonstrated in [Section 3.6.2.2 on page 56](#).

NOTE: The bandwidth calculation represented by the above equation is only approximate. As the programmed value of Audio\_Res\_Genlock becomes larger, the approximation becomes more accurate.

NOTE2: The value programmed in the Audio\_Res\_Genlock register must be between 32 and 42. The value programmed in the Audio\_Cap\_Genlock register must be greater than 10. These limits define the exact range of loop bandwidth adjustment available.

### 3.6.5 Locking to Digital Timing from a Deserializer

As described in [Section 3.4.1 on page 43](#), the GS4911B/GS4910B may be genlocked to either an analog reference, such as a Black & Burst signal, or to an SDI input via the digital H, V, and F blanking signals normally produced by a deserializer. When locking to an SDI input, the user should consider the possibility of a switch of the SDI signal upstream from the system.

If the GS4911B/GS4910B is locked to the digital H, V, and F blanking signals produced by a deserializer, and the SDI input to the deserializer is switched such that the phase of the H input changes abruptly, the REF\_LOST output will remain LOW and the GS4911B/GS4910B will not crash lock to the new H phase. Instead, the clock and timing outputs will very slowly drift towards the new phase. During this period of drift, the LOCK\_LOST output will be LOW, even though the device is not genlocked.

The user should clear the Run\_Window bits [2:0] of register address 24h to force the device to crash lock should such a switch occur. This will cause the GS4911B/GS4910B to crash lock whenever it sees a disturbance of the input H signal.

NOTE: Any action that causes an abrupt phase change of the H input to the GS4911B/GS4910B such that REF\_LOST is not triggered will cause the device to respond in the manner described above.

In addition to the slow drifting behaviour outlined above, there may also be a random phase difference between the input VSYNC and output V Sync signals occurring each time a switch in the SDI stream causes an abrupt phase change of the H input to the GS4911B/GS4910B. This will only occur when attempting to lock the “*f/1.001*” HD output standards to the 525-line SD input references standards, or vice versa. For cases where the user must manually video genlock the device, the problem will occur whenever the value programmed for H\_Reference\_Divide (registers 2B-2Ah) is greater than 1. All line-based timing outputs are affected.

The only way to ensure a constant phase difference between the input VSYNC signal and the line-based timing outputs is to reset the line-based counters after such a switch occurs. This is achieved by toggling bit 15 of register address 83h in the host interface. The device will then delay all line-based output timing signals by  $\Delta V_{sync}$  lines relative to the input VSYNC reference, as described in NOTE 3 of [Section 3.2.1.1 on page 38](#).

## 3.7 Clock Synthesis

The clock synthesis circuit generates the video/graphics clocks based on the VID\_STD[5:0] pins and host register settings. In the GS4911B, the clock synthesis circuit also generates the audio clock signals based on the ASR\_SEL[2:0] pins and host register settings.

The generated video and audio clocks may be further divided and are presented to the application layer via pins PCLK1-PCLK3 and ACLK1-ACLK3 respectively.

### 3.7.1 Video Clock Synthesis

The programmable video clock generator is referenced to an internal crystal oscillator and is responsible for generating the PCLK output signals.

The crystal oscillator requires an external 27MHz crystal connected to pins X1 and X2, or can be driven at LVTTTL levels from an external 27MHz source connected to X1. These two configurations are shown in [Figure 1-1](#).

A range of 8 different video sample clock rates and 13 different graphic display clock rates may be selected using the VID\_STD[5:0] pins of the device. [Section 1.4 on page 20](#) lists the video and graphic formats available using the VID\_STD[5:0] pins. Once the device is powered up and an initial output format is selected using VID\_STD[5:0], the video clock rate may also be modified via the host interface (see [Section 3.9 on page 72](#)).

If desired, the external VID\_STD[5:0] pins may be ignored by setting bit 1 of the Video\_Control register, and the video standard may instead be selected via the VID\_STD[5:0] register of the host interface (see [Section 3.12.3 on page 79](#)). Although the external VID\_STD[5:0] pins will be ignored, they should not be left floating.

NOTE: If VID\_STD[5:0] is set to 62 on power-up, the video clock will run at a frequency based on the internal default settings of the chip until the user programs registers 20h to

23h. Please see [Section 3.9 on page 72](#) for a detailed explanation of custom clock generation.

Once the video clock has been generated, it will be presented to the application layer via the PCLK1 to PCLK3 pins. By default, each of the 3 video clock outputs will produce the generated fundamental clock frequency. However, it is possible to select other rates for each PCLK output by programming the PCLK\_Phase/Divide registers beginning at address 2Ch of the host interface (see [Section 3.12.3 on page 79](#)).

Each PCLK output may be individually programmed to provide one of the following:

- PCLK fundamental frequency
- Fundamental frequency /2
- Fundamental frequency /4

When all six VID\_STD[5:0] pins are set LOW, the video clocks will be disabled. PCLK1 and PCLK2 will go LOW and PCLK3/ $\overline{\text{PCLK3}}$  will be high impedance.

NOTE: If the PCLK divider bits of registers 2Ch - 2Eh are set to enable a divide by 2 or divide by 4, the resultant divided clock will align with the falling edge of the output H Sync timing signal either on its rising or falling edge.

The PCLK1 to PCLK3 outputs may also be individually delayed with respect to the eight TIMING\_OUT signals to allow for skew control downstream from the GS4911B/GS4910B. Using the PCLK\_Phase/Divide registers, the phase of each clock may be delayed up to a nominal 10.3ns in 16 steps of approximately 700ps each ([Table 3-6](#)). This delay is available in addition to the genlock timing offset phase adjustment described in [Section 3.2.1 on page 38](#).

**Table 3-6: Video Clock Phase Adjustment Host Settings**

PCLKn_Phase[3:0] Setting	0	1h	2h	3h	4h	5h	6h	7h	8h	9h	Ah	Bh	Ch	Dh	Eh	Fh
Phase Increment (ns)	0	0.7	1.4	2.1	2.8	3.5	4.2	4.9	5.6	6.3	7.0	7.7	8.4	9.1	9.8	10.3

**NOTES:**

1. The phase increments listed above are nominal values.
2. The phase of PCLK is delayed relative to the TIMING\_OUT pins.

Additionally, the current drive capability of PCLK1 and PCLK2 may be set high or low using the PCLK\_Phase/Divide registers. By default the current drive will be low. It must be set high if the clock rate is greater than 100MHz.

### 3.7.2 Audio Clock Synthesis (GS4911B only)

The programmable audio clock generator is referenced to the internal PCLK signal and is responsible for generating the ACLK output signals. Three audio clock output pins, ACLK1 to ACLK3, are available to the application layer.

The fundamental sampling frequency,  $f_s$ , is selected using the ASR\_SEL[2:0] pins as shown in Table 3-7. Once selected, the audio clock rate may be customized via the host interface (see Section 3.9 on page 72).

If desired, the external ASR\_SEL[2:0] pins may be ignored by setting bit 2 of the Audio\_Control register and the sampling frequency may instead be programmed in the ASR\_SEL[2:0] register of the host interface (see Section 3.12.3 on page 79). Although the external ASR\_SEL[2:0] pins will be ignored, they should not be left floating.

**Table 3-7: Audio Sample Rate Select**

ASR_SEL[2:0]	Sampling Frequency (kHz)
000	Audio Clock Generation Disabled
001	32
010	44.1
011	48
100	96
101	Slow 32*
110	Slow 44.1*
111	Slow 48*

\*Slow 32, 44.1, and 48 are available only when the video standard selected is 23.98, 29.97, or 59.94 frame rate based. They refer to 32kHz, 44.1kHz, or 48kHz multiplied by 1000/1001 to maintain the 1, 2, or 3 frame sequence normally associated with 24, 30, and 60 fps video.

When all three ASR\_SEL[2:0] pins are set LOW, the audio clock outputs will be high impedance. In this case, the application layer may continue to power the AUD\_PLL\_VDD pin; however, to minimize noise and power consumption, AUD\_PLL\_VDD may be grounded.

By default, after system reset, ACLK1 to ACLK3 will output clock signals at 256 $f_s$ , 64 $f_s$ , and  $f_s$  respectively. Different division ratios for each output pin may be selected by programming the ACLK\_fs\_Multiple registers beginning at address 3Fh of the host interface (see Section 3.12.3 on page 79). The encoding of this register is shown in Table 3-8. Clock outputs of 512 $f_s$ , 348 $f_s$ , 256 $f_s$ , 192 $f_s$ , 128 $f_s$ , 64 $f_s$ ,  $f_s$ , and z bit are selectable on a pin by pin basis. The z bit will go HIGH for one  $f_s$  period every 192  $f_s$  periods. Its phase is not defined by any timing event in the GS4911B, and so is arbitrary.

**Table 3-8: Audio Clock Divider**

ACLKn_fs_Multiple[3:0]	Audio Clock Frequency
000	fs
001	64fs
010	128fs
011	192fs*
100	256fs
101	384fs*
110	512fs**
111	z-bit

\*This setting is only available when the enable\_384fs bit of the Audio\_Control register is HIGH.

\*\*512fs clock will have a 33% duty cycle when the enable\_384fs bit is HIGH and fs = 96kHz.

The fs signal on ACLK1-3 has an accurate 50% duty cycle, and can be used for left/right definition, with the following exception: if fs = 96kHz and the user configures the host interface such that one of the three ACLK pins is set to output a clock signal at 192fs or 384fs, the 512fs clock will have a 33% duty cycle.

All audio clocks are initially reset on the rising edge of the AFS pulse, ensuring that video to audio clock synchronization is correct. During normal operation, the audio clock edge is allowed to drift slightly with respect to the AFS pulse. By default, the audio clock will be reset directly by the AFS pulse if it drifts more than approximately +/-0.1us from the rising edge of the AFS pulse. However, after device reset, or after the application of a new input reference, the ACLK outputs may sometimes be offset from the AFS pulse by up to several microseconds. The offset will remain until the device is reset or the reference removed and re-applied. The user may avoid this offset by minimizing the width of the AFS\_Reset\_Window using bits 9-7 of register 31h for the duration of the audio PLL locking process. Once the audio PLL is locked, bit 1 of register 1Fh will be set HIGH, and the AFS\_Reset\_Window may be set as desired. See [Table 3-9](#).

NOTE: To maintain correct audio clock frequencies for some VESA standards, the window tolerance shown in [Table 3-9](#) may have to be increased from its default setting. In this case, set the AFS\_Reset\_Window register to 1XX.



**Table 3-9: Encoding Scheme for AFS\_Reset\_Window**

AFS_Reset_Window (address 31h)	Window Tolerance (us)				
	fs = 32kHz	fs = 44.1kHz	fs = 48 kHz	fs = 96 kHz (enable_384fs = 1)	fs = 96 kHz (enable_384fs = 0)
000	0.044	0.033	0.030	0.030	0.044
001	0.084	0.062	0.057	0.057	0.084
010 (default)	0.166	0.121	0.112	0.112	0.166
011	0.329	0.239	0.220	0.220	0.329
1XX	0.654	0.475	0.437	0.437	0.654

NOTE: 'X' signifies 'don't care.' The bit setting will be ignored.

### 3.7.2.1 Audio to Video Clock Phasing

The important aspect of the audio to video phase relates to the way in which the AFS pulse is used to reset the audio clock dividers so as to line up the leading edge of the audio clocks with the leading edge of the H Sync pulse on line 1 of the first field in the audio frame sequence. The AFS pulse is further discussed in [Section 3.8.2 on page 68](#).

#### 625i 50 Format

For the 48kHz sampling rate, the audio to video phase relationship for 625/50i reference signals is provided by the device in accordance with the EBU recommended practice R83-1996. The start of an audio frame (fs clock) will align with the 50% point of the H sync input of line 1 of each video frame (+/- the allowable drift specified in [Table 3-9](#)).

#### 525i 59.94 Format

For 525/59.94 NTSC reference signals, the device will observe the 5-frame phase-relationship inherent with this video standard, aligning the audio clocks with the 50% point of the H sync input of line 1 on every fifth frame (+/- the allowable drift specified in [Table 3-9](#)).

The number of audio sample clocks during a video frame is shown in [Table 3-10](#) for 32, 44.1, and 48kHz audio sampling frequencies.

**Table 3-10: Audio Sampling Frequency to Video Frame Rate Synchronization**

Audio Sample Rate (kHz)	Audio Samples per Video Frame						
	24fps	25fps	29.97fps	30fps	50fps	59.94fps	60fps
32	4000/3	1280	16016/15	3200/3	640	8008/15	1600/3
44.1	3675/2	1764	147147/100	1470	882	147147/200	735
48	2000	1920	8008/5	1600	960	4004/5	800

\* fps = frames per second.

The external 10FID input pin may be used to resynchronize other audio clock frequencies, according to [Table 3-10](#), by applying an active signal during the reference HSYNC of line 1 of the appropriate video frame. Please see [Section 3.4.2 on page 44](#) for more details on the 10FID input pin.

In the case where 10FID is not present as a reference signal, the GS4911B will automatically generate an AFS pulse appropriate to the format selected, and use it to create an audio frame sequence.

### Host Interface Control of AFS and 10FID

Alternatively, the user may program the device via the host interface to re-time the audio frame sequence and 10 field-ID. Using register 1Ah, a pulse may be generated to reset the AFS and/or 10FID dividers at the start of an output video frame (see [Section 3.12.3 on page 79](#)).

If using the host interface to reset the AFS pulse, the device may be configured to ignore the input 10FID reference pin. To disable the signal on the external 10FID pin from resetting the AFS output pulse, set bit 0 of the Audio\_Control register HIGH.

If using the host interface to reset the 10FID pulse, the external 10FID pin must be grounded.

## 3.8 Video Timing Generator

The internal PCLK signal generated by the clock synthesis circuit is used to produce horizontal, vertical, and frame based timing output signals.

The signals generated and available to the application layer via the TIMING\_OUT pins are: H Sync, H Blanking, V Sync, V Blanking, F Sync, F Digital, DE, 10FID, AFS (GS4911B only), and USER\_1~4. These signals are defined in [Section 1.5 on page 26](#). Additional information pertaining to the 10FID, AFS, and USER\_1~4 signals can be found in the sub-sections below.

When the GS4911B/GS4910B is operating in Genlock mode, the H, V, and F based output timing signals are synchronized to the H, V, and F reference signals applied to the inputs by the application layer. The video timing outputs may be offset from the input reference by programming the Genlock Offset registers beginning at address 1Bh of the host interface (see [Section 3.2.1.1 on page 38](#)).

All TIMING\_OUT signals have selectable polarity. The default polarities for each signal are given in the descriptions in [Section 1.5 on page 26](#).

### 3.8.1 10 Field ID Pulse

As described in [Table 1-3](#), the 10 field ID (10FID) output signal is used in the identification of film to video cadence. It is only generated for 29.97, 30, 59.94, and 60fps formats.

The 10FID pulse is generated on every 5<sup>th</sup> frame for 29.97 and 30fps formats, and every 10<sup>th</sup> frame on 59.94 and 60fps formats.

By default, the 10FID signal is set HIGH on the leading edge of the H Sync output for the duration of line 1 of field 1 at the start of the 10 field sequence. This is shown in [Figure 3-8](#).

Alternatively, by setting bit 4 of the Video\_Control register at address 4Ch of the host interface, the 10FID output signal may be configured to go HIGH (default polarity) on the leading edge of the H Sync pulse of line 1 of the first field in the 10 field sequence, and be reset LOW on the leading edge of the H Sync pulse of line 1 of the second field in the 10 field sequence. This is shown in [Figure 3-9](#).

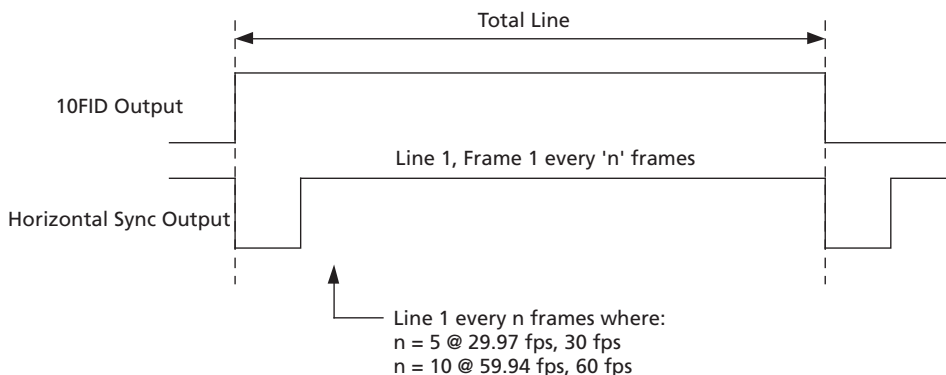

Figure 3-8: Default 10FID Output Timing

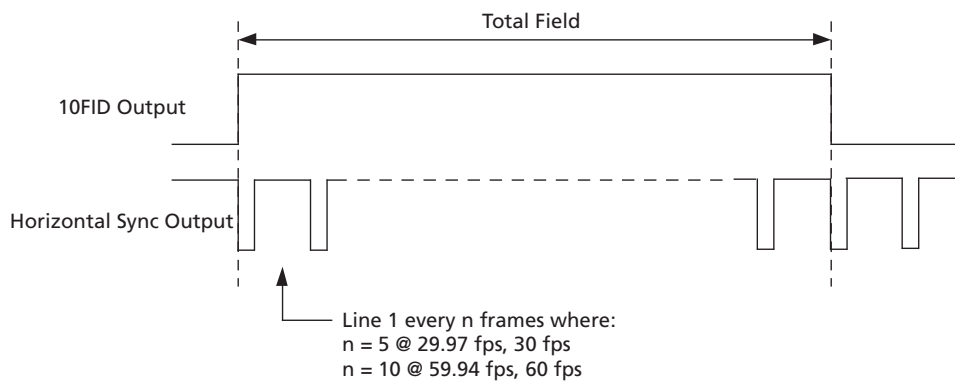

Figure 3-9: Optional 10FID Output Timing

The phasing of the divide by n frame counter may be reset by an external pulse on the 10FID input pin, or via register 1Ah of the host interface (see [Section 3.12.3 on page 79](#)).

NOTE: If a 10FID input signal is not provided to the device, the 10FID output signal will be invalid until the user initiates a reset via the host interface. The user should also reset the 10FID signal via the host if at any time the H input reference signal is removed and then re-applied.

### 3.8.2 Audio Frame Synchronizing Pulse (GS4911B only)

As described in [Table 1-3](#), the audio frame synchronizing (AFS) pulse identifies the frame, within an n frame sequence, in which the audio sample rate clock is aligned with the H Sync of line 1. It is generated for all video formats.

The leading edge of the AFS output pulse is co-timed with the H Sync corresponding to line 1 of every n<sup>th</sup> frame in the sequence, and therefore identifies the exact time at which the audio sample rate clock and video PCLK have synchronous leading edges.

The number of frames in the sequence, n, is determined by the video frame rate and the audio clock frequency. These are selected using the VID\_STD[5:0] and ASR\_SEL[2:0] pins or via the host interface.

By default, the AFS pulse is 1 line long, as shown in [Figure 3-10](#). Alternatively, by setting bit 1 of the Audio\_Control register, the AFS output signal may be configured to go HIGH on the leading edge of the H Sync pulse of line 1 of the first field in the 'n' frame sequence, and be reset LOW on the leading edge of the H Sync pulse of line 1 of the second field in the sequence. The AFS timing in this configuration is similar to the 10FID optional timing shown in [Figure 3-9](#).

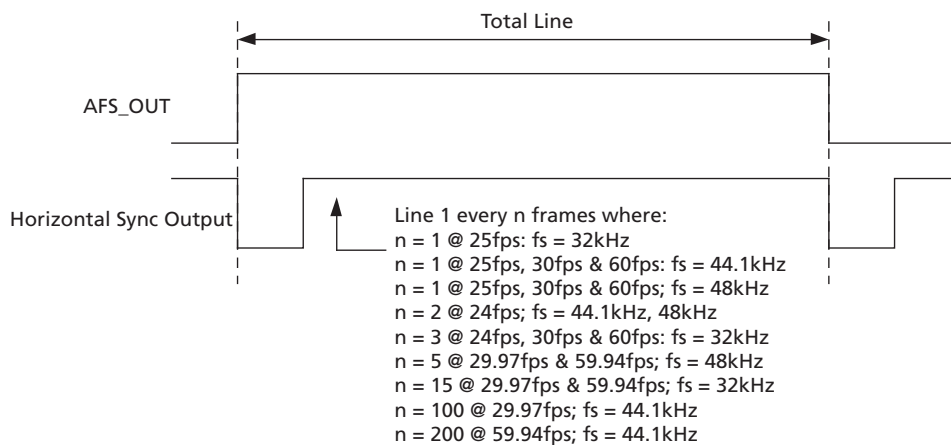

Figure 3-10: AFS Output Timing

The phasing of the divide by n counter can be controlled by the 10FID input or via designated registers in the host interface.

By default, the 10FID input pin controls the AFS phase (in addition to controlling the 10FID phase); however, this feature may be disabled by setting bit 0 of the Audio\_Control register (see Section 3.12.3 on page 79). In addition, the AFS signal may be reset via register 1Ah.

### 3.8.3 USER\_1~4

As described in Table 1-3, the GS4911B/GS4910B offers 4 user programmable output signals which are available independent of the selected output video format.

Each user signal is individually programmable and the polarity, position, and width of each output may be defined with respect to the digital output timing of the device. Each output signal may be programmed in both the horizontal and vertical dimensions relative to the leading edges of H blanking and V blanking. If desired, the pulses produced may then be combined with a logical AND, OR, or XOR function to produce a composite signal (for example, a horizontal back porch pulse during active lines only, or the active part of lines 15 through 20 for vertical information retrieval).

By default, the AND, OR, and XOR functions are disabled. Therefore, when a USER signal is selected using the Output\_Select registers of the host interface, the signal will go LOW (default polarity) at the H\_Start pixel and return HIGH after the H\_Stop pixel. Setting the AND bit HIGH, for example, will cause the USER signal to be active only when USER\_H is active and USER\_V is active (i.e. the pixel is between both H\_Start and H\_Stop and V\_Start and V\_Stop). See Figure 3-11.

NOTE: The effective horizontal range of the four user-defined timing signals is [H\_Start + 1, H\_Stop], except when H\_Start = 1, in which case the range is [H\_Start, H\_Stop]. This prevents the user from specifying an output USER signal that begins on pixel 2 of a line.

In the case of interlaced output formats, the programmed vertical start and stop lines refer to the start and stop lines of the generated USER signal on field 1. The start and stop lines of the USER signal on the even fields will be V\_Start - 1 and V\_Stop - 1, respectively.

For example, if VID\_STD[5:0] = 3, field 1 will have 263 lines and field 2 will have 262 lines. A user-defined vertical pulse programmed to start on line 12 and stop on line 17 will start on frame lines 12 and 274, and stop on frame lines 17 and 279.

The designated registers for programming each user signal are located in the host interface beginning at address 57h. See [Section 3.12.3 on page 79](#).

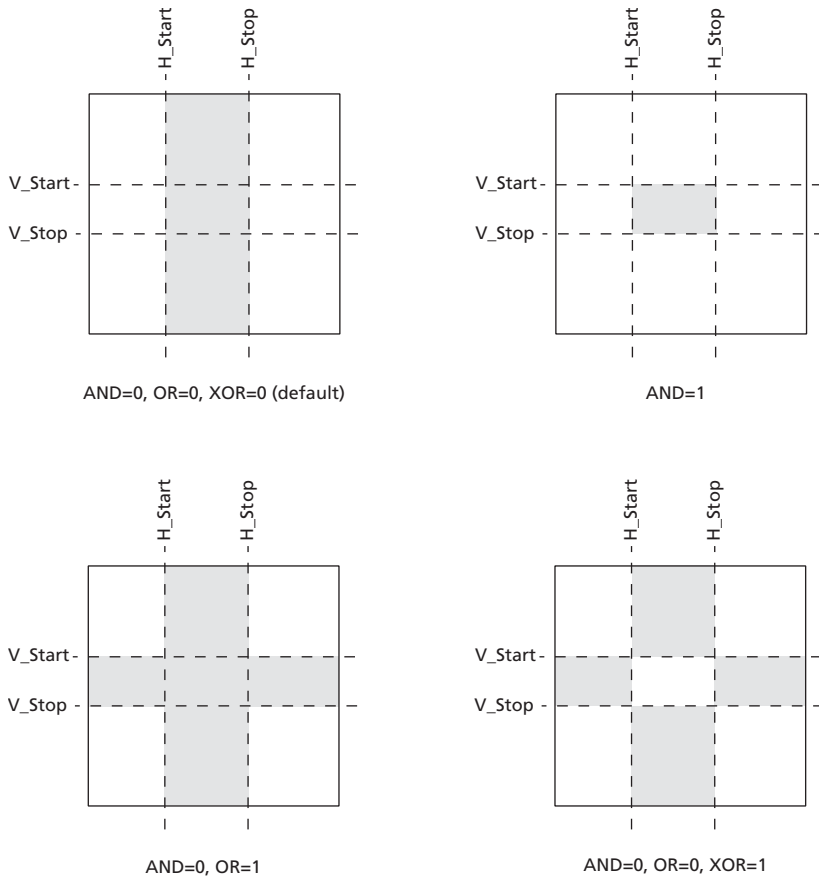

Shading indicates when USER\_x signal is active

Figure 3-11: USER Programmable Output Signal

### 3.8.4 TIMING\_OUT Pins

The horizontal, vertical, and frame based timing output signals for the selected video format are available to the application layer via the TIMING\_OUT\_1 to TIMING\_OUT\_8 pins.

#### Programmable Crosspoint Switch

Each TIMING\_OUT pin outputs a default signal as shown in Table 1-3. Alternatively, a crosspoint switch may be programmed via the eight Output\_Select registers of the host interface, allowing the user to select which output signal is directed to each TIMING\_OUT pin (see Section 3.12.3 on page 79). Any signal may be sent to more than one pin if desired.

Table 3-11 outlines the encoding scheme of the eight Output\_Select registers, which begin at address 43h of the host interface.

**Table 3-11: Crosspoint Select**

Output_Select_n Bit Settings	Output Signal
0000	High Impedance
0001	H Sync
0010	H Blanking
0011	V Sync
0100	V Blanking
0101	F Sync
0110	F Digital
0111	10FID
1000	DE
1001	Reserved
1010	AFS*
1011	USER_1
1100	USER_2
1101	USER_3
1110	USER_4
1111	Reserved

\*AFS is only available on the GS4911B. The bit setting 1010b will be ignored by the GS4910B.

### 3.8.4.1 Selectable Current Drive and Polarity

The current-drive of each timing output pin is also selectable via the Output\_Select registers. The current drive of each TIMING\_OUT pin is low by default. However, it may be set high to accommodate certain applications.

Additionally, the Polarity register of the host interface may be programmed to select the polarity of each timing output signal.

## 3.9 Custom Clock Generation

In addition to the device's pre-programmed clock frequencies, the user may generate a custom audio or video clock by programming designated registers in the host interface.

Custom video clock generation is supported by both the GS4910B and GS4911B and is described in [Section 3.9.1 on page 72](#). Custom audio clock generation is only supported by the GS4911B and is described in [Section 3.9.2 on page 73](#).

### 3.9.1 Programming a Custom Video Clock

The fundamental frequency of the video clock is defined by the output video format initially set by VID\_STD[5:0]. At any time, this fundamental frequency may be modified to create a custom output video format.

The user may generate a video clock with any frequency between 13.5MHz and 165MHz. By programming the PCLK\_Divide registers, the output PCLK may be as low as  $13.5/4 = 3.375\text{MHz}$ .

Generating a custom video clock will change the period of the video timing signals presented to the TIMING\_OUT pins; however, the pixels per line, lines per frame, and other pixel and line-based timing signals will remain unchanged. To redefine the pixel and line based timing parameters, registers 4Eh to 55h must be reprogrammed as described in [Section 3.10 on page 74](#).

The frequency of the custom video clock is determined using a ratio based on the 27MHz reference. Therefore, to program a custom clock, the user must calculate and program the set of integers ( $N_v$ ,  $D_v$ ) in the equation:

$$\frac{N_v}{D_v} = \frac{f_{out}}{f_{in}}$$

where:

$f_{out}$  = desired output video clock frequency

$f_{in}$  = 27MHz crystal reference

$N_v$  = numerator of the ratio (host register 20h-21h)

$D_v$  = denominator of the ratio (host register 22h-23h)



Before programming  $N_v$  and  $D_v$ , the numerator and denominator must be reduced to their lowest factors. Two examples are given below:

Example 1: Programming an output video clock of 74.25MHz:

$$\frac{f_{out}}{f_{in}} = \frac{74.25\text{MHz}}{27\text{MHz}}$$

$$\therefore \frac{N_v}{D_v} = \frac{7425}{2700} = \frac{11}{4}$$

Therefore, program  $N_v = 11$  and  $D_v = 4$ .

Example 2: Programming an output video clock of 74.175824MHz (74.25/1.001):

$$\frac{f_{out}}{f_{in}} = \frac{74.25\text{MHz}}{1.001 \times 27\text{MHz}}$$

$$\therefore \frac{N_v}{D_v} = \frac{7425 \times 1000}{2700 \times 1001} = \frac{250}{91}$$

Therefore, program  $N_v = 250$  and  $D_v = 91$ .

NOTE: The  $N_v$  and  $D_v$  values programmed in registers 20h-21h and 22h-23h are not held until the custom video clock update bit (6) of register 16h is toggled.

### 3.9.2 Programming a Custom Audio Clock (GS4911B only)

The GS4911B's audio clocks are derived from the fundamental audio sampling frequency initially set by ASR\_SEL[2:0]. At any time this fundamental sampling frequency may be modified to create a custom output audio clock.

The user may generate any audio sampling frequency between 6.6kHz and 96kHz, and therefore create a custom audio clock as high as 512\*96kHz. When generating a custom audio sampling frequency, ASR\_SEL[2:0] must be set to 100b and bit 5 of register 31h (enable\_384fs) must be kept LOW.

The fundamental sampling frequency is determined using a ratio based on the 27MHz reference. Therefore, to program a custom audio clock, the user must calculate and program the set of integers ( $N_a$ ,  $D_a$ ) in the equation:

$$\frac{N_a}{D_a} = 1024 \times \frac{f_s}{f_{in}}$$

where:

$f_s$  = desired fundamental audio sampling frequency

$f_{in}$  = 27MHz crystal reference

$N_a$  = numerator of the ratio (host register 33h-34h)

$D_a$  = denominator of the ratio (host register 35h-36h)

Before programming  $N_a$  and  $D_a$ , the numerator and denominator must be reduced to their lowest factors.

For example, to program a fundamental audio sampling frequency of 42kHz:

$$\frac{N_a}{D_a} = 1024 \times \frac{42000}{27000000} = \frac{43008}{27000} = \frac{1792}{1125}$$

Therefore, program  $N_a = 1792$  and  $D_a = 1125$  and toggle the custom audio clock update bit (6) of register 31h. Using registers 3Fh to 41h, the custom audio sampling frequency generated may then be multiplied by a factor of 64, 128, 256, or 512 before being presented to the ACLK pins.

NOTE: The AFS reset described in [Section 3.7.2 on page 63](#) will always remain active.

### 3.10 Custom Output Timing Signal Generation

In addition to the devices's pre-programmed output timing signals, the user may also build their own custom timing signals. This is achieved by setting VID\_STD[5:0] = 62 and programming designated host registers.

When programming custom output timing signals, the user must define the pixel, line, and field/frame timing parameters using registers 4Eh to 55h of the host interface (see [Figure 3-12](#)). For all custom formats, the VSync output will start on line 1 of the video field. The user may delay the VSync pulse to any line using the V\_Offset register (see [Section 3.2.1.1](#)).

When the user sets VID\_STD[5:0] = 62, registers 4Eh to 55h will become read/write configurable and the device will initially continue to output timing signals based on the video format previously selected. Once the user has programmed all eight custom timing registers, generation of the new timing signals will begin.

The frequency of the video clock will remain as previously selected unless otherwise modified as described in [Section 3.9.1 on page 72](#).

NOTE: If VID\_STD[5:0] = 62 on power-up, the initial output timing signals will be set to the internal default timing of the chip until the user programs 4Eh to 55h.

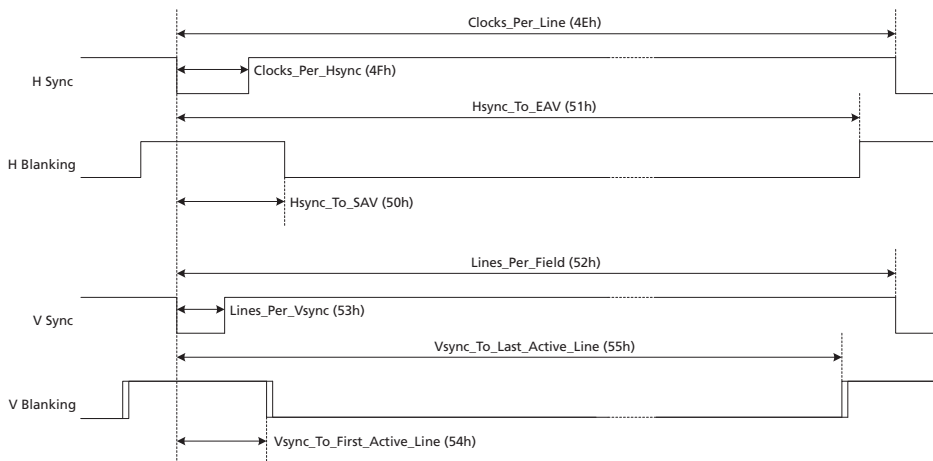

Figure 3-12: Custom Timing Parameters

### 3.10.1 Custom Input Reference

As explained in [Section 3.5.2 on page 46](#), when VID\_STD[5:0] = 62, the device will only verify that a stable signal with a period of less than 2.4ms is present on the HSYNC input pin before attempting to genlock. Therefore, in addition to programming custom output timing signals, the user may genlock the output timing signals to a custom reference pulse applied to HSYNC. In this case the user is required to manually program the video genlock block (see [Section 3.6.2.1 on page 54](#)).

## 3.11 Extended Audio Mode for HD Demux using the Genum Audio Core

The GS4911B/GS4910B has been designed to interface with Genum's FPGA Audio Core in order to provide a 24.576MHz clock (512 \* 48kHz) locked to the audio clock contained in the embedded audio data packets of an HD-SDI stream. It is the responsibility of the user to divide this clock by 4 to obtain the 6.144MHz required by the core.

In HD Demux mode, the FPGA Audio Core will extract an audio clock from the embedded audio data packets and present a 24kHz clock to the GS4911B/GS4910B via the aclkdiv2a (for Group A) and aclkdiv2b (for Group B) outputs. The embedded clock must be 48kHz.

The 24kHz reference signals for each audio group must be applied to the HSYNC input pin of a GS4911B/GS4910B, while a divided version of this signal must be applied to the VSYNC input pin. The divided signal must meet the requirements for VSYNC validity given in [Section 3.5.2 on page 46](#). It is recommended that the VSYNC signal be generated by dividing the 24kHz reference applied to HSYNC by 512 to give 46.875Hz.

To enable the extended audio mode, the user must do the following:

1. Set VID\_STD[5:0] = 04h.
2. Set the F\_Lock\_Mask and V\_Lock\_Mask bits [4:3] of register address 16h to 1.
3. Set the Ext\_Audio\_Mode register address 81h to 20C1h.
4. Toggle the Update\_Custom\_V\_Clock bit [6] of register address 16h.

In this mode, the GS4911B/GS4910B will produce a 24.576MHz clock on its PCLK output pins that is locked to the 24kHz extracted audio clock reference applied to HSYNC. It will not lock to any other reference frequency. The user may then divide this frequency by 4 using the programmable dividers in the GS4911B/GS4910B.

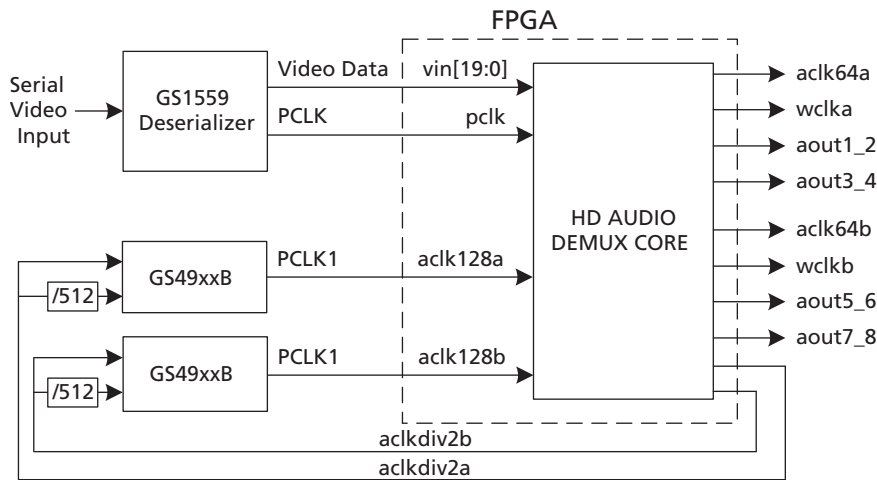

Figure 3-13: Audio Clock Block Diagram for HD Demux Operation

### 3.12 GSPI Host Interface

The GSPI, or Gennum Serial Peripheral Interface, is a 4-wire interface provided to allow the host to enable additional features of the GS4911B/GS4910B and/or to provide additional status information through configuration registers in the device.

The GSPI comprises a serial data input signal, SDIN, a serial data output signal, SDOUT, an active low chip select,  $\overline{CS}$ , and a burst clock, SCLK. The burst clock must have a duty cycle between 40% and 60%.

Because these pins are shared with the JTAG interface port, an additional control signal pin, JTAG/ $\overline{HOST}$  is provided. When JTAG/ $\overline{HOST}$  is LOW, the GSPI interface is enabled.

When operating in GSPI mode, the SCLK, SDIN, and  $\overline{CS}$  signals are provided by the application interface. The SDOUT pin is a non-clocked loop-through of SDIN and may be connected to the SDIN pin of another device, allowing multiple devices to be connected to the GSPI chain. The interface is illustrated in [Figure 3-14](#).

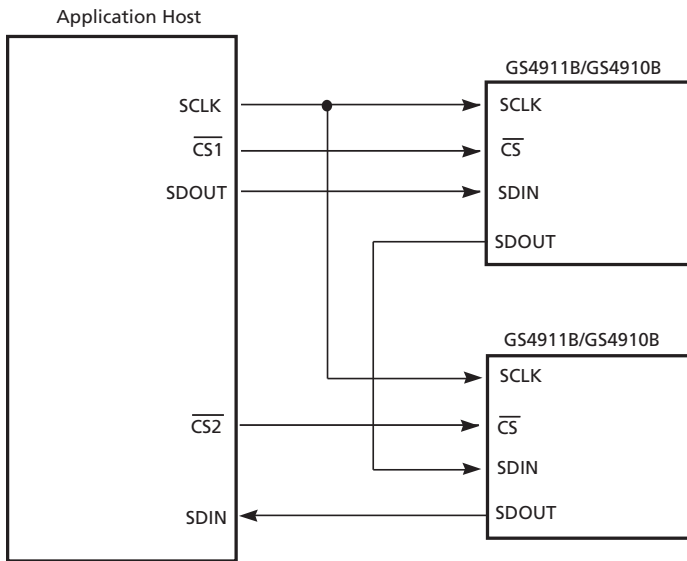

Figure 3-14: GSPI Application Interface Connection

All read or write access to the GS4911B/GS4910B is initiated and terminated by the host processor. Each access always begins with a 16-bit command word on SDIN indicating the address of the register of interest. This is followed by a 16-bit data word on SDIN in write mode, or a 16-bit data word on SDOUT in read mode.

### 3.12.1 Command Word Description

The command word consists of 16 bits transmitted MSB first and includes a read/write bit, an Auto-Increment bit and a 12-bit address. Figure 3-15 shows the command word format and bit configurations.

Command words are clocked into the GS4911B/GS4910B on the rising edge of the serial clock, SCLK, which operates in a burst fashion.

When the Auto-Increment bit is set LOW, each command word must be followed by only one data word to ensure proper operation. If the Auto-Increment bit is set HIGH, the following data word will be written into the address specified in the command word, and subsequent data words will be written into incremental addresses. This facilitates multiple address writes without sending a command word for each data word.

Auto-Increment may be used for both read and write access.

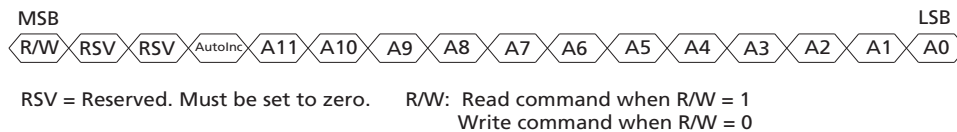

Figure 3-15: Command Word Format

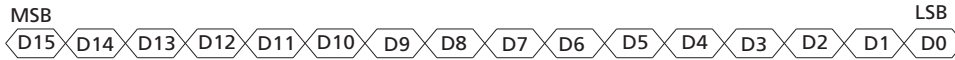

Figure 3-16: Data Word Format

### 3.12.2 Data Read and Write Timing

Read and write mode timing for the GSPI interface is shown in Figure 3-17 and Figure 3-18 respectively. The timing parameters are defined in Table 3-12.

When several devices are connected to the GSPI chain, only one  $\overline{CS}$  should be asserted during a read sequence.

During the write sequence, all command and following data words input at the SDIN pin are output at the SDOUT pin as is. Where several devices are connected to the GSPI chain, data can be written simultaneously to all the devices that have  $\overline{CS}$  set LOW.

Table 3-12: GSPI Timing Parameters

Parameter	Definition	Specification
$t_0$	The minimum duration of time chip select, $\overline{CS}$ , must be LOW before the first SCLK rising edge.	1.5 ns
$t_1$	The minimum SCLK period.	100 ns
$t_2$	Duty cycle tolerated by SCLK.	40% to 60%
$t_3$	Minimum input setup time.	1.5 ns
$t_4$	The minimum duration of time between the last SCLK command word (or data word if the Auto-Increment bit is HIGH) and the first SCLK of the data word (write cycle).	37.1 ns
$t_5$	The minimum duration of time between the last SCLK command word (or data word if the Auto-Increment bit is HIGH) and the first SCLK of the data word (read cycle).	148.4 ns
$t_6$	Minimum output hold time (15pF load).	1.5 ns
$t_7$	The minimum duration of time between the last SCLK of the GSPI transaction and when $\overline{CS}$ can be set HIGH.	37.1 ns
$t_8$	Minimum input hold time.	1.5 ns

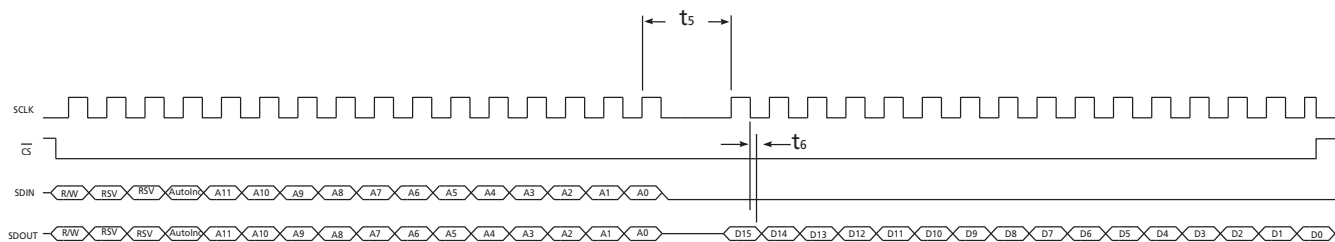

Figure 3-17: GSPI Read Mode Timing

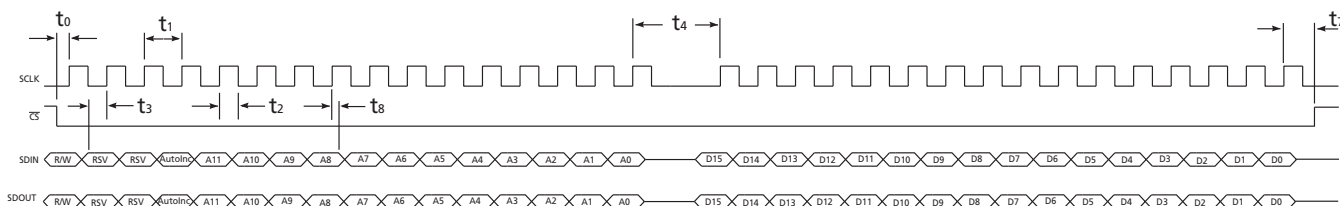

Figure 3-18: GSPI Write Mode Timing

### 3.12.3 Configuration and Status Registers

Table 3-13 summarizes the GS4911B/GS4910B's internal status and configuration registers.

All registers are available to the host via the GSPI and are all individually addressable.

Table 3-13: Configuration and Status Registers

Register Name	Address	Bit	Description	R/W	Default
RSVD	00h - 09h	-	Reserved.	-	-
H_Period	0Ah	15-0	Contains the number of 27MHz pulses in the input H Sync period. This register is set by the Reference Format Detector block using the H Sync signal present on the external HSYNC input pin. NOTE: If the reference is removed this register will remain unchanged until a new reference with a different HSYNC period is applied. Reference: <a href="#">Section 3.5.1 on page 45</a>	R	N/A

**Table 3-13: Configuration and Status Registers (Continued)**

Register Name	Address	Bit	Description	R/W	Default
H_16_Period	0Bh	15-0	<p>Contains the number of 27MHz pulses in 16 H Sync periods. This register is set by the Reference Format Detector block using the H Sync signal present on the external HSYNC input pin. It is useful for 1/1.001 data detection.</p> <p>NOTE: If the reference is removed this register will remain unchanged until a new reference with a different HSYNC period is applied.</p> <p>Reference: <a href="#">Section 3.5.1 on page 45</a></p>	R	N/A
V_Lines	0Ch	15-0	<p>Contains the number of H Sync periods in the input V Sync interval. This register is set by the Reference Format Detector block using the signals present on the external HSYNC and VSYNC input pins.</p> <p>NOTE: If the reference is removed this register will remain unchanged until a new reference with a different VSYNC period is applied.</p> <p>Reference: <a href="#">Section 3.5.1 on page 45</a></p>	R	N/A
V_2_Lines	0Dh	15-0	<p>Contains the number of H Sync periods in 2 V Sync intervals. This register is set by the Reference Format Detector block using the signals present on the external HSYNC and VSYNC input pins.</p> <p>NOTE: If the reference is removed this register will remain unchanged until a new reference with a different VSYNC period is applied.</p> <p>Reference: <a href="#">Section 3.5.1 on page 45</a></p>	R	N/A
F_Lines	0Eh	15-0	<p>Contains the number of H Sync periods in the input F Sync interval. This register is set by the Reference Format Detector block using the signals present on the external HSYNC and FSYNC input pins.</p> <p>NOTE: If the reference is removed this register will remain unchanged until a new reference is applied. If the new reference does not include an FSYNC pulse, this register will be set to zero.</p> <p>Reference: <a href="#">Section 3.5.1 on page 45</a></p>	R	N/A



**Table 3-13: Configuration and Status Registers (Continued)**

Register Name	Address	Bit	Description	R/W	Default
H_16_Period	0Bh	15-0	<p>Contains the number of 27MHz pulses in 16 H Sync periods. This register is set by the Reference Format Detector block using the H Sync signal present on the external HSYNC input pin. It is useful for 1/1.001 data detection.</p> <p>NOTE: If the reference is removed this register will remain unchanged until a new reference with a different HSYNC period is applied.</p> <p>Reference: <a href="#">Section 3.5.1 on page 45</a></p>	R	N/A
V_Lines	0Ch	15-0	<p>Contains the number of H Sync periods in the input V Sync interval. This register is set by the Reference Format Detector block using the signals present on the external HSYNC and VSYNC input pins.</p> <p>NOTE: If the reference is removed this register will remain unchanged until a new reference with a different VSYNC period is applied.</p> <p>Reference: <a href="#">Section 3.5.1 on page 45</a></p>	R	N/A
V_2_Lines	0Dh	15-0	<p>Contains the number of H Sync periods in 2 V Sync intervals. This register is set by the Reference Format Detector block using the signals present on the external HSYNC and VSYNC input pins.</p> <p>NOTE: If the reference is removed this register will remain unchanged until a new reference with a different VSYNC period is applied.</p> <p>Reference: <a href="#">Section 3.5.1 on page 45</a></p>	R	N/A
F_Lines	0Eh	15-0	<p>Contains the number of H Sync periods in the input F Sync interval. This register is set by the Reference Format Detector block using the signals present on the external HSYNC and FSYNC input pins.</p> <p>NOTE: If the reference is removed this register will remain unchanged until a new reference is applied. If the new reference does not include an FSYNC pulse, this register will be set to zero.</p> <p>Reference: <a href="#">Section 3.5.1 on page 45</a></p>	R	N/A

**Table 3-13: Configuration and Status Registers (Continued)**

Register Name	Address	Bit	Description	R/W	Default
Input_Standard	0Fh	15-13	Reserved. Set these bits to zero when writing to 0Fh.	–	–
	0Fh	12	Force_Input - Set this bit HIGH to force the GS4911B/GS4910B to recognize the applied input reference format as the standard programmed in bits 11-6 of this register. Reference: <a href="#">Section 3.2.1.2 on page 41</a>	R/W	0
	0Fh	11-6	Forced_Standard - When bit 12 is set HIGH, the GS4911B/GS4910B will use the value programmed in these bits, rather than the value in bits 5-0, to determine the input reference format. The 6-bit value programmed here should always correspond to the VID_STD[5:0] value of the applied reference. These bits should only be programmed as part of the Freeze mode procedure described in <a href="#">Section 3.2.1.2 on page 41</a> .	R/W	0
	0Fh	5-0	Detected_Standard - Contains the video standard applied to the input reference pins once it has been detected. These bits are set by the Reference Format Detector block and correspond to the VID_STD[5:0] value of the standard as listed in <a href="#">Table 1-2</a> . The Detected_Standard bits will be set to zero if no input reference signal is applied or if the input reference signal is not an automatically recognized video format. Otherwise the value will be between 1 and 54. Reference: <a href="#">Section 3.5.2 on page 46</a>	R/W	N/A
Amb_Std_Sel	10h	15-11	Reserved. Set these bits to zero when writing to 10h.	–	–
	10h	10-0	The user may set this register to distinguish between different formats that look identical to the internal Reference Format Detector block. See <a href="#">Table 3-2</a> . Reference: <a href="#">Section 3.5.2.1 on page 46</a>	R/W	0
Reference_Standard_Disable	14h-11h	63-0	The Reference_Standard_Disable registers may be used to disable one or more of the recognized input standards from being used to genlock the output. This is done by setting the bit HIGH that corresponds to the VID_STD[5:0] value of the video standard in <a href="#">Table 1-2</a> . For example, if bit 5 is set HIGH, then the output clock and timing signals will not genlock to an input reference with timing corresponding to VID_STD[5:0] = 5 in <a href="#">Table 1-2</a> . Address 11h = bits 15-0 Address 12h = bits 31-16 Address 13h = bits 47-32 Address 14h = bits 63-48 Reference: <a href="#">Section 3.6 on page 50</a>	R/W	0

**Table 3-13: Configuration and Status Registers (Continued)**

Register Name	Address	Bit	Description	R/W	Default
Genlock_Status	15h	15-6	Reserved.	–	–
	15h	5	Reference_Lock - this bit will be HIGH when the output is successfully genlocked to the input (i.e. when bits 4-1 of this register are HIGH and are not masked by bits 4-2 of register 16h). The LOCK_LOST output pin is an inverted copy of this bit. Reference: <a href="#">Section 3.6.1 on page 50</a>	R	N/A
	15h	4	F_Lock - this bit will be HIGH when the output F is successfully genlocked to the FSYNC input. NOTE: If the input reference does not include an FSYNC input, this bit will have the same setting as V_Lock (bit 3). Reference: <a href="#">Section 3.6.1 on page 50</a>	R	N/A
	15h	3	V_Lock - this bit will be HIGH when the output V is successfully genlocked to the VSYNC input. Reference: <a href="#">Section 3.6.1 on page 50</a>	R	N/A
	15h	2	H_Lock - this bit will be HIGH when the output H is successfully genlocked to the HSYNC input. Reference: <a href="#">Section 3.6.1 on page 50</a>	R	N/A
	15h	1	Clock_Lock - this bit will be HIGH when the video clock is locked to the internal V_pll AND the audio clock is locked to the internal A_pll (i.e. bits 0 and 1 of register 1Fh are HIGH). Reference: <a href="#">Section 3.6.1 on page 50</a>	R	N/A
	15h	0	Reference_Present - this bit will be HIGH when a valid input reference signal has been applied to the device. The REF_LOST output pin is an inverted copy of this bit. Reference: <a href="#">Section 3.5.2 on page 46</a>	R	N/A

**Table 3-13: Configuration and Status Registers (Continued)**

Register Name	Address	Bit	Description	R/W	Default
Genlock_Control	16h	15-7	Reserved. Set these bits to zero when writing to 16h.	–	–
	16h	6	Update_Custom_V_Clock - this bit is used to update the custom video clock parameters programmed in registers 20h to 23h of the host interface. All non-zero parameters in these registers will be updated via a LOW to HIGH transition on this bit. This bit is also used to enable the Extended Audio Mode of the device.	R/W	0
	16h	5	Genlock_From_Host - set this bit HIGH to enable video genlock control via the Host Interface instead of the external GENLOCK pin (see bit 0 of this register). Reference: <a href="#">Section 3.2 on page 37</a>	R/W	0
	16h	4	F_Lock_Mask - if this bit is set HIGH, the GS4911B/GS4910B will ignore the status of F_Lock (bit 4 of register 15h) when determining the status of Reference_Lock (bit 5 of register 15h). Reference: <a href="#">Section 3.6.1 on page 50</a>	R/W	0
	16h	3	V_Lock_Mask - if this bit is set HIGH, the GS4911B/GS4910B will ignore the status of V_Lock (bit 3 of register 15h) when determining the status of Reference_Lock (bit 5 of register 15h). Reference: <a href="#">Section 3.6.1 on page 50</a>	R/W	0
	16h	2	H_Lock_Mask - if this bit is set HIGH, the GS4911B/GS4910B will ignore the status of H_Lock (bit 2 of register 15h) when determining the status of Reference_Lock (bit 5 of register 15h). Reference: <a href="#">Section 3.6.1 on page 50</a>	R/W	0
	16h	1	Drift_Crash - when this bit is set HIGH, the generated video clock will drift lock to a new input reference rather than crash lock. Reference: <a href="#">Section 3.6.3 on page 58</a>	R/W	0
	16h	0	GENLOCK - this bit may be used instead of the external pin to Genlock the output video format to the input reference. This bit will be ignored if bit 5 of this register is LOW. Reference: <a href="#">Section 3.2 on page 37</a>	R/W	0

**Table 3-13: Configuration and Status Registers (Continued)**

Register Name	Address	Bit	Description	R/W	Default
Output_H_Reset	17h	15-0	<p>When the output is genlocked to the input, the input reference is used to reset the line-based counter controlling the generated timing output signals.</p> <p>Programming this register to a non-zero value will over-ride the internal pixel-based counter. The counter reset will occur every Output_H_Reset lines instead of on a frame basis.</p> <p>This register is programmed when manually programming the internal video genlock block.</p> <p>The default value of this register will vary depending on the output video standard selected.</p> <p>Reference: <a href="#">Section 3.6.2 on page 54</a></p>	R/W	–
Output_FV_Reset	18h	15-0	<p>When the output is genlocked to the input, the input reference is used to reset the frame-based counter controlling the generated timing output signals.</p> <p>Programming this register to a non-zero value will over-ride the internal frame-based counter. The counter reset will occur every Output_FV_Reset input frames.</p> <p>This register is programmed when manually programming the internal video genlock block.</p> <p>NOTE: Once this register is programmed, it must be updated using register 19h.</p> <p>The default value of this register will vary depending on the output video standard selected.</p> <p>Reference: <a href="#">Section 3.6.2 on page 54</a></p>	R/W	–
Frame_Divider_Reset	19h	15-2	Reserved. Set these bits to zero when writing to 19h.	–	–
	19h	1	<p>Ref_F_Sync - when Ref_F_Mode (bit 0 of 19h) is set HIGH, this bit is used to initialize the frame-based counter reset programmed in 18h.</p> <p>The reset pulse is generated if this bit is pulsed (LOW to HIGH to LOW) during the output frame immediately prior to the frame the reset is to occur.</p> <p>This register is programmed when manually programming the internal video genlock block.</p> <p>Reference: <a href="#">Section 3.6.2 on page 54</a></p>	R/W	0
	19h	0	<p>Ref_F_Mode - set this bit HIGH to initialize the frame-based reset via the host interface (using bit 1 above).</p> <p>Reference: <a href="#">Section 3.6.2 on page 54</a></p>	R/W	0

**Table 3-13: Configuration and Status Registers (Continued)**

Register Name	Address	Bit	Description	R/W	Default
10FID_AFS_Reset	1Ah	15-4	Reserved. Set these bits to zero when writing to 1Ah.	–	–
	1Ah	3	AFS_Reset (GS4911B only) - set this bit HIGH to use Reset_Sync (bit 0 of register 1Ah) to reset the output AFS pulse.  NOTE: This bit will remain LOW in the GS4910B. Set this bit LOW when writing to address 1Ah of the GS4910B.  Reference: <a href="#">Section 3.7.2.1 on page 65</a>	R/W	0
	1Ah	2	10FID_Reset - set this bit HIGH to use Reset_Sync (bit 0 of register 1Ah) to reset the output 10FID pulse.  NOTE: If a 10FID input signal is not provided to the device, the user must generate a reset using this bit to initiate the 10FID timing output. In this case, the 10FID input pin must be grounded.  Reference: <a href="#">Section 3.7.2.1 on page 65</a>	R/W	0
	1Ah	1	Reserved. Set this bit to zero when writing to 1Ah.	–	–
	1Ah	0	Reset_Sync - resets the pulses described in bits 2, and 3 above.  The reset pulse is generated if this bit is pulsed (LOW to HIGH to LOW) during the output frame immediately prior to the frame the reset is to occur. This reset will operate independently of any other resets, for example from the reference input.	R/W	0
H_Offset	1Bh	15-0	The output H signal may be delayed with respect to the input reference by the number of pixels programmed in this register. (See <a href="#">Section 3.2.1.1 on page 38</a> ).  The value programmed in this register should not exceed the maximum number of clock periods per line of the outgoing standard. Horizontal advances may be achieved by programming a value equal to the maximum allowable offset minus the desired advance.  NOTE: This register is internally read by the device once per field. At that time any new value programmed is sent to the internal offset circuitry.  Reference: <a href="#">Section 3.2.1.1 on page 38</a>	R/W	0

**Table 3-13: Configuration and Status Registers (Continued)**

Register Name	Address	Bit	Description	R/W	Default
V_Offset	1Ch	15-0	<p>The output V signal may be delayed with respect to the input reference by the number of lines programmed in this register. (See <a href="#">Section 3.2.1.1 on page 38</a>).</p> <p>The value programmed in this register should not exceed the maximum number of lines per frame of the outgoing standard. Vertical advances may be achieved by programming a value equal to the maximum allowable offset minus the desired advance.</p> <p>NOTE: This register is internally read by the device once per field. At that time any new value programmed is sent to the internal offset circuitry.</p> <p>Reference: <a href="#">Section 3.2.1.1 on page 38</a></p>	R/W	0
Clock_Phase_Offset	1Dh	15-0	<p>Phase_Offset - The output clock and data phase may be offset with respect to the input reference by the number of increments programmed in this register. The increment step size depends on the video clock frequency.</p> <p>The encoding scheme for this register is shown in <a href="#">Table 3-1</a>.</p> <p>NOTE: This register must be cleared to achieve a clock phase offset of zero.</p> <p>Reference: <a href="#">Section 3.2.1.1 on page 38</a></p>	R/W	0
Max_Ref_Delta	1Eh	15-0	<p>The value programmed in this register controls the allowed deviance from the expected frequency on the reference HSYNC before the internal video PLL loses lock. The encoding scheme is shown in <a href="#">Table 3-3</a>.</p> <p>Reference: <a href="#">Section 3.5.4 on page 49</a></p>	R/W	000Bh

**Table 3-13: Configuration and Status Registers (Continued)**

Register Name	Address	Bit	Description	R/W	Default
Video_Status	1Fh	15-5	Reserved.	–	–
	1Fh	4	Ref_H_Polarity - status register to indicate the detected H Sync polarity ('1' for positive, '0' for negative). This bit will be zero when no reference signal is present. Reference: <a href="#">Section 3.4.3 on page 45</a>	R	N/A
	1Fh	3	Ref_V_Polarity - status register to indicate the detected V Sync polarity ('1' for positive, '0' for negative). This bit will be zero when no reference signal is present and for digital blanking input references. Reference: <a href="#">Section 3.4.3 on page 45</a>	R	N/A
	1Fh	2	Ref_Blank_Timing - status register to indicate the input detection of H blanking vs. H sync timing ('1' for blanking, '0' for sync timing). This bit will be zero when no reference signal is present. Reference: <a href="#">Section 3.4.3 on page 45</a>	R	N/A
	1Fh	1	A_pll_Lock (GS4911B only)- this bit will be HIGH when the generated audio clock is locked to the video clock reference. NOTE: This bit will remain high in the GS4910B. Reference: bit 1 of register 15h.	R	N/A
Video_Status	1Fh	0	V_pll_Lock - this bit will be HIGH when the generated video clock is locked to the H Sync input reference. Reference: bit 1 of register 15h.	R	N/A
N <sub>v</sub>	21h-20h	31-0	A non-zero number programmed in this register defines the numerator for the ratio of the video clock to the 27MHz reference. This register can be used for creating custom video clock frequencies. NOTE: Once this register is programmed, it must be updated using bit 6 of register 16h. The default value of this register will vary depending on the output video standard selected. Address 20h = bits 15-0 Address 21h = bits 31-16 Reference: <a href="#">Section 3.9.1 on page 72</a>	R/W	–



**Table 3-13: Configuration and Status Registers (Continued)**

Register Name	Address	Bit	Description	R/W	Default
D <sub>v</sub>	23h-22h	31-0	<p>A non-zero number programmed in this register defines the denominator for the ratio of the video clock to the 27MHz reference.</p> <p>This register can be used for creating custom video clock frequencies.</p> <p>NOTE: Once this register is programmed, it must be updated using bit 6 of register 16h.</p> <p>The default value of this register will vary depending on the output video standard selected.</p> <p>Address 22h = bits 15-0 Address 23h = bits 31-16</p> <p>Reference: <a href="#">Section 3.9.1 on page 72</a></p>	R/W	–
Constcf_Genlock	24h	15-8	<p>Crash_Time - controls the crash lock period of video PLL locking process. This time contributes to the total PLL Lock Time given in the AC Characteristics Table.</p> <p>The time of the crash process in H reference periods is determined by [Crash_Time x 4] + 1.</p> <p>The default value of these bits will vary depending on the output video standard selected.</p> <p>Reference: <a href="#">Section 3.6.3 on page 58</a></p>	R/W	–
	24h	7-3	<p>Lock_Lost_Threshold - controls the threshold of the lock indication circuit. A larger value programmed in this register can increase the stability of the LOCK_LOST output signal when the input H reference signal is subject to large amounts of low frequency jitter. A larger value in this register will also increase the lock indication time, although not the actual lock time of the device.</p> <p>The default value of these bits will vary depending on the output video standard selected.</p>	R/W	–
	24h	2-0	<p>Run_Window - controls the output frequency error in the case of a missing or mis-timed H reference transition. The default value of this register allows the device to maintain genlock through one missing input H pulse.</p> <p>This feature can be disabled by programming Run_Window = 000b. In this case, the device will immediately react to any disturbance of the input H signal.</p> <p>The default value of these bits will vary depending on the output video standard selected.</p> <p>Reference: <a href="#">Section 3.5.3 on page 47</a></p>	R/W	–
RSVD	25h	–	Reserved.	–	–

**Table 3-13: Configuration and Status Registers (Continued)**

Register Name	Address	Bit	Description	R/W	Default
Video_Cap_Genlock	26h	15-6	Reserved. Set these bits to zero when writing to 26h.	–	–
	26h	5-0	Control signal to adjust loop bandwidth of video genlock block. The value programmed in this register must be between 10 and Video_Res_Genlock - 21. The default value of this register will vary depending on the output video standard selected. Reference: <a href="#">Section 3.6.4 on page 58</a>	R/W	–
Video_Res_Genlock	27h	15-6	Reserved. Set these bits to zero when writing to 27h.	–	–
	27h	5-0	Control signal to adjust loop bandwidth of video genlock block. The value programmed in this register must be between 32 and 42. The default value of this register will vary depending on the output video standard selected. Reference: <a href="#">Section 3.6.4 on page 58</a>	R/W	–
H_Feedback_Divide	29h-28h	31-0	In the internal video genlock block, this register defines the numerator of the divide ratio. This register may be programmed to manually genlock the output to the input reference. The default value of this register will vary depending on the output video standard selected. Address 28h = bits 15-0 Address 29h = bits 31-16 Reference: <a href="#">Section 3.6.2.1 on page 54</a>	R/W	–
H_Reference_Divide	28h-2Ah	31-0	In the internal video genlock block, this register defines the denominator of the divide ratio. This register may be programmed to manually genlock the output to the input reference. The default value of this register will vary depending on the output video standard selected. Address 2Ah = bits 15-0 Address 28h = bits 31-16 Reference: <a href="#">Section 3.6.2.1 on page 54</a>	R/W	–

**Table 3-13: Configuration and Status Registers (Continued)**

Register Name	Address	Bit	Description	R/W	Default
PCLK1_Phase/Divide	2Ch	15-7	Reserved. Set these bits to zero when writing to 2Ch.	–	–
	2Ch	6	Current_P1 - selects the current drive capability of the PCLK1 pin. Set this bit HIGH for high current drive. Otherwise, the current drive will be low. NOTE: The current drive should be set high if PCLK1 is greater than 100MHz. Reference: <a href="#">Section 3.7.1 on page 61</a>	R/W	0
	2Ch	5-2	PCLK1_Phase - adjusts the output phase of the PCLK1 clock with respect to the timing output pins. Phase is delayed in 700ps (nominal) increments as shown in <a href="#">Table 3-6</a> . Reference: <a href="#">Section 3.7.1 on page 61</a>	R/W	0
	2Ch	1	Divide_By_4 - set this bit HIGH to divide the output PCLK1 by four. NOTE: Setting this bit and bit 0 simultaneously HIGH will hold the PCLK1 pin LOW. Reference: <a href="#">Section 3.7.1 on page 61</a>	R/W	0
	2Ch	0	Divide_By_2 - set this bit HIGH to divide the output PCLK1 by two. NOTE: Setting this bit and bit 1 simultaneously HIGH will hold the PCLK1 pin LOW. Reference: <a href="#">Section 3.7.1 on page 61</a>	R/W	0
PCLK2_Phase/Divide	2Dh	15-7	Reserved. Set these bits to zero when writing to 2Dh.	–	–
	2Dh	6	Current_P2 - selects the current drive capability of the PCLK2 pin. Set this bit HIGH for high current drive. Otherwise, the current drive will be low. NOTE: The current drive should be set high if PCLK2 is greater than 100MHz. Reference: <a href="#">Section 3.7.1 on page 61</a>	R/W	0
	2Dh	5-2	PCLK2_Phase - adjusts the output phase of the PCLK2 clock with respect to the timing output pins. Phase is delayed in 700ps (nominal) increments as shown in <a href="#">Table 3-6</a> . Reference: <a href="#">Section 3.7.1 on page 61</a>	R/W	0
	2Dh	1	Divide_By_4 - set this bit HIGH to divide the output PCLK2 by four. NOTE: Setting this bit and bit 0 simultaneously HIGH will hold the PCLK2 pin LOW. Reference: <a href="#">Section 3.7.1 on page 61</a>	R/W	0
	2Dh	0	Divide_By_2 - set this bit HIGH to divide the output PCLK2 by two. NOTE: Setting this bit and bit 1 simultaneously HIGH will hold the PCLK2 pin LOW. Reference: <a href="#">Section 3.7.1 on page 61</a>	R/W	0

**Table 3-13: Configuration and Status Registers (Continued)**

Register Name	Address	Bit	Description	R/W	Default
PCLK3_Phase/Divide	2Eh	15-6	Reserved. Set these bits to zero when writing to 2Eh.	–	–
	2Eh	5-2	PCLK3_Phase - adjusts the output phase of the PCLK3/ $\overline{\text{PCLK3}}$ clock with respect to the timing output pins. Phase is delayed in 700ps (nominal) increments as shown in Table 3-6. Reference: Section 3.7.1 on page 61	R/W	0
	2Eh	1	Divide_By_4 - set this bit HIGH to divide the output PCLK3/ $\overline{\text{PCLK3}}$ by four. Setting this bit and bit 0 simultaneously HIGH will give the full rate video clock on the PCLK3 / $\overline{\text{PCLK3}}$ pins. Reference: Section 3.7.1 on page 61	R/W	0
	2Eh	0	Divide_By_2 - set this bit HIGH to divide the output PCLK3/ $\overline{\text{PCLK3}}$ by two. Setting this bit and bit 1 simultaneously HIGH will give the full rate video clock on the PCLK3 / $\overline{\text{PCLK3}}$ pins. Reference: Section 3.7.1 on page 61	R/W	0
PCLK3_Tristate	2Fh	15-2	Reserved. Set these bits to zero when writing to 2Fh.	–	–
	2Fh	1-0	Set these bits to 11b to tristate the PCLK3 / $\overline{\text{PCLK3}}$ pins. Reference: Section 3.7.1 on page 61	R/W	00b
RSVD	2Fh - 30h	–	Reserved.	–	–

**Table 3-13: Configuration and Status Registers (Continued)**

Register Name	Address	Bit	Description	R/W	Default
Audio_Control (GS4911B only)	31h	15-10	Reserved. Set these bits to zero when writing to 31h.	–	–
	31h	9-7	AFS_Reset_Window - These bits may be used to adjust the value by which the audio clock counters are allowed to drift from the output AFS pulse. The encoding scheme for this register is shown in <a href="#">Table 3-9</a> .  NOTE: The default setting of this register will provide a reset window that is sufficient for most standards. To maintain correct audio clock frequencies for some VESA standards, the reset window may have to be increased from its default setting. In this case, set the value of this register to 1XX. See <a href="#">Table 3-9</a> .  Reference: <a href="#">Section 3.7.2 on page 63</a>	R/W	010b
	31h	6	Update_Custom_A_Clock - this bit is used to update the custom audio clock parameters programmed in registers 33h to 36h of the host interface. All non-zero parameters in these registers will be updated via a LOW to HIGH transition on this bit.	R/W	0
	31h	5	Enable_384fs - set this bit HIGH to enable the 384fs and 192fs audio clock outputs. This must be set in addition to registers 3Fh to 41h.  NOTE: If this bit is HIGH, then a 512fs audio clock will have a 33% duty cycle when fs = 96kHz.  Reference: <a href="#">Section 3.7.2 on page 63</a>	R/W	0
	31h	4-3	Reserved. Set these bits to zero when writing to 31h.	–	–
	31h	2	Host_ASR_SEL - set this bit HIGH to select the audio sample rate using register 32h instead of the external ASR_SEL[2:0] pins. The external ASR_SEL[2:0] pins will be ignored, but should not be left floating.  Reference: <a href="#">Section 3.7.2 on page 63</a>	R/W	0
	31h	1	AFS_F_Pulse - set this bit to 1 to stretch the AFS pulse duration from 1 line to 1 field.  Reference: <a href="#">Section 3.8.2 on page 68</a>	R/W	0
	31h	0	AFS_Reset_Disable - set this bit HIGH to disable the 10FID input reference pin from resetting the output AFS pulse. If this bit is set HIGH, the output AFS pulse will free-run or may be reset using register 1Ah. The external 10FID pin should not be left floating.  Reference: <a href="#">Section 3.8.2 on page 68</a>	R/W	0

**Table 3-13: Configuration and Status Registers (Continued)**

Register Name	Address	Bit	Description	R/W	Default
ASR_SEL[2:0] (GS4911B only)	32h	15-3	Reserved. Set these bits to zero when writing to 32h.	–	–
	32h	2-0	Replaces the external ASR_SEL[2:0] pins when Host_ASR_Select (bit 2 of address 31h) is HIGH. The default setting of this register corresponds to an audio sample rate of 48kHz. Reference: <a href="#">Section 3.7.2 on page 63</a>	R/W	011b
N <sub>a</sub> (GS4911B only)	34h-33h	31-0	A non-zero number programmed in this register defines the numerator for the ratio of the audio clock to the 27MHz reference.  NOTE: Once this register is programmed, it must be updated using bit 6 of register 31h.  The default value of this register will vary depending on the output audio rate selected. Address 33h = bits 15-0 Address 34h = bits 31-16 Reference: <a href="#">Section 3.9.2 on page 73</a> .	R/W	–
D <sub>a</sub> (GS4911B only)	36h-35h	31-0	A non-zero number programmed in this register defines the denominator for the ratio of the audio clock to the 27MHz reference.  NOTE: Once this register is programmed, it must be updated using bit 6 of register 31h.  The default value of this register will vary depending on the output audio rate selected. Address 35h = bits 15-0 Address 36h = bits 31-16 Reference: <a href="#">Section 3.9.2 on page 73</a> .	R/W	–
RSVD	37h - 38h	–	Reserved.	–	–
Audio_Cap_Genlock (GS4911B only)	39h	15-6	Reserved. Set these bits to zero when writing to 39h.	–	–
	39h	5-0	Control signal to adjust loop bandwidth of audio genlock block. The value programmed in this register must be between 10 and Audio_Res_Genlock - 21. The default value of this register will depend on the fundamental sampling frequency selected. Reference: <a href="#">Section 3.6.4 on page 58</a>	R/W	–
Audio_Res_Genlock (GS4911B only)	3Ah	15-6	Reserved. Set these bits to zero when writing to 3Ah.	–	–
	3Ah	5-0	Control signal to adjust loop bandwidth of audio genlock block. The value programmed in this register must be between 32 and 42. The default value of this register will depend on the fundamental sampling frequency selected. Reference: <a href="#">Section 3.6.4 on page 58</a>	R/W	–

**Table 3-13: Configuration and Status Registers (Continued)**

Register Name	Address	Bit	Description	R/W	Default
A_Feedback_Divide (GS4911B only)	3Ch-3Bh	31-0	In the internal audio genlock block, this register defines the numerator of the divide ratio.  This register may be programmed to manually genlock the audio clock to the video clock.  The default value of this register will vary depending on the output video standard selected. Address 3Bh = bits 15-0 Address 3Ch = bits 31-16 Reference: <a href="#">Section 3.6.2.2 on page 56</a>	R/W	–
A_Reference_Divide (GS4911B only)	3Eh-3Dh	31-0	In the internal audio genlock block, this register defines the denominator of the divide ratio.  This register may be programmed to manually genlock the audio clock to the video clock.  The default value of this register will vary depending on the output video standard selected. Address 3Dh = bits 15-0 Address 3Eh = bits 31-16 Reference: <a href="#">Section 3.6.2.2 on page 56</a>	R/W	–
ACLK1_fs_Multiple (GS4911B only)	3Fh	15-3	Reserved. Set these bits to zero when writing to 3Fh.	–	–
	3Fh	2-0	The user may set this register to select the desired frequency of the audio clock on ACLK1 (a multiple of the fundamental sampling rate, fs). The audio clock frequency may be set as: 512fs, 384fs, 256fs, 192fs, 128fs, 64fs, fs, or z-bit. See <a href="#">Table 3-8</a> for more details.  NOTE: To output a frequency of 348fs or 192fs, bit 5 of register 31h must also be set HIGH. Reference: <a href="#">Section 3.7.2 on page 63</a>	R/W	0
ACLK2_fs_Multiple (GS4911B only)	40h	15-3	Reserved. Set these bits to zero when writing to 40h.	–	–
	40h	2-0	The user may set this register to select the desired frequency of the audio clock on ACLK2 (a multiple of the fundamental sampling rate, fs). The audio clock frequency may be set as: 512fs, 384fs, 256fs, 192fs, 128fs, 64fs, fs, or z-bit. See <a href="#">Table 3-8</a> for more details.  NOTE: To output a frequency of 348fs or 192fs, bit 5 of register 31h must also be set HIGH. Reference: <a href="#">Section 3.7.2 on page 63</a>	R/W	0

**Table 3-13: Configuration and Status Registers (Continued)**

Register Name	Address	Bit	Description	R/W	Default
ACLK3_fs_Multiple (GS4911B only)	41h	15-3	Reserved. Set these bits to zero when writing to 41h.	–	–
	41h	2-0	The user may set this register to select the desired frequency of the audio clock on ACLK3 (a multiple of the fundamental sampling rate, fs). The audio clock frequency may be set as: 512fs, 384fs, 256fs, 192fs, 128fs, 64fs, fs, or z-bit. See <a href="#">Table 3-8</a> for more details.  NOTE: To output a frequency of 348fs or 192fs, bit 5 of register 31h must also be set HIGH.  Reference: <a href="#">Section 3.7.2 on page 63</a>	R/W	0
RSVD	42h	–	Reserved.	–	–
Output_Select_1	43h	15-5	Reserved. Set these bits to zero when writing to 43h.	–	–
	43h	4	Current_1 - selects the current drive capability of the TIMING_OUT_1 pin. Set this bit HIGH for high current drive. Otherwise, the current drive will be low.  Reference: <a href="#">Section 3.8.4 on page 71</a>	R/W	0
	43h	3-0	This register is used to select one of the 10 pre-programmed or 4 user programmed timing signals available for output on the TIMING_OUT_1 pin. See <a href="#">Table 3-11</a> for more details.  Note: The default setting of this register is 0001b, which corresponds to H Sync.  Reference: <a href="#">Section 3.8.4 on page 71</a>	R/W	0001b
Output_Select_2	44h	15-5	Reserved. Set these bits to zero when writing to 44h.	–	–
	44h	4	Current_2 - selects the current drive capability of the TIMING_OUT_2 pin. Set this bit HIGH for high current drive. Otherwise, the current drive will be low.  Reference: <a href="#">Section 3.8.4 on page 71</a>	R/W	0
	44h	3-0	This register is used to select one of the 10 pre-programmed or 4 user programmed timing signals available for output on the TIMING_OUT_2 pin. See <a href="#">Table 3-11</a> for more details.  Note: The default setting of this register is 0010b, which corresponds to H Blanking.  Reference: <a href="#">Section 3.8.4 on page 71</a>	R/W	0010b



**Table 3-13: Configuration and Status Registers (Continued)**

Register Name	Address	Bit	Description	R/W	Default
Output_Select_3	45h	15-5	Reserved. Set these bits to zero when writing to 45h.	–	–
	45h	4	Current_3 - selects the current drive capability of the TIMING_OUT_3 pin. Set this bit HIGH for high current drive. Otherwise, the current drive will be low. Reference: <a href="#">Section 3.8.4 on page 71</a>	R/W	0
	45h	3-0	This register is used to select one of the 10 pre-programmed or 4 user programmed timing signals available for output on the TIMING_OUT_3 pin. See <a href="#">Table 3-11</a> for more details. Note: The default setting of this register is 0011b, which corresponds to V Sync. Reference: <a href="#">Section 3.8.4 on page 71</a>	R/W	0011b
Output_Select_4	46h	15-5	Reserved. Set these bits to zero when writing to 46h.	–	–
	46h	4	Current_4 - selects the current drive capability of the TIMING_OUT_4 pin. Set this bit HIGH for high current drive. Otherwise, the current drive will be low. Reference: <a href="#">Section 3.8.4 on page 71</a>	R/W	0
	46h	3-0	This register is used to select one of the 10 pre-programmed or 4 user programmed timing signals available for output on the TIMING_OUT_4 pin. See <a href="#">Table 3-11</a> for more details. Note: The default setting of this register is 0100b, which corresponds to V Blanking. Reference: <a href="#">Section 3.8.4 on page 71</a>	R/W	0100b
Output_Select_5	47h	15-5	Reserved. Set these bits to zero when writing to 47h.	–	–
	47h	4	Current_5 - selects the current drive capability of the TIMING_OUT_5 pin. Set this bit HIGH for high current drive. Otherwise, the current drive will be low. Reference: <a href="#">Section 3.8.4 on page 71</a>	R/W	0
	47h	3-0	This register is used to select one of the 10 pre-programmed or 4 user programmed timing signals available for output on the TIMING_OUT_5 pin. See <a href="#">Table 3-11</a> for more details. Note: The default setting of this register is 0101b, which corresponds to F Sync. Reference: <a href="#">Section 3.8.4 on page 71</a>	R/W	0101b

**Table 3-13: Configuration and Status Registers (Continued)**

Register Name	Address	Bit	Description	R/W	Default
Output_Select_6	48h	15-5	Reserved. Set these bits to zero when writing to 48h.	–	–
	48h	4	Current_6 - selects the current drive capability of the TIMING_OUT_6 pin. Set this bit HIGH for high current drive. Otherwise, the current drive will be low. Reference: <a href="#">Section 3.8.4 on page 71</a>	R/W	0
	48h	3-0	This register is used to select one of the 10 pre-programmed or 4 user programmed timing signals available for output on the TIMING_OUT_6 pin. See <a href="#">Table 3-11</a> for more details. Note: The default setting of this register is 0110b, which corresponds to F Digital. Reference: <a href="#">Section 3.8.4 on page 71</a>	R/W	0110b
Output_Select_7	49h	15-5	Reserved. Set these bits to zero when writing to 49h.	–	–
	49h	4	Current_7 - selects the current drive capability of the TIMING_OUT_7 pin. Set this bit HIGH for high current drive. Otherwise, the current drive will be low. Reference: <a href="#">Section 3.8.4 on page 71</a>	R/W	0
	49h	3-0	This register is used to select one of the 10 pre-programmed or 4 user programmed timing signals available for output on the TIMING_OUT_7 pin. See <a href="#">Table 3-11</a> for more details. Note: The default setting of this register is 0111b, which corresponds to 10FID. Reference: <a href="#">Section 3.8.4 on page 71</a>	R/W	0111b
Output_Select_8	4Ah	15-5	Reserved. Set these bits to zero when writing to 4Ah.	–	–
	4Ah	4	Current_8 - selects the current drive capability of the TIMING_OUT_8 pin. Set this bit HIGH for high current drive. Otherwise, the current drive will be low. Reference: <a href="#">Section 3.8.4 on page 71</a>	R/W	0
	4Ah	3-0	This register is used to select one of the 10 pre-programmed or 4 user programmed timing signals available for output on the TIMING_OUT_8 pin. See <a href="#">Table 3-11</a> for more details. Note: The default setting of this register is 1000b, which corresponds to Display Enable (DE). Reference: <a href="#">Section 3.8.4 on page 71</a>	R/W	1000b
RSVD	4Bh	–	Reserved.	–	–

**Table 3-13: Configuration and Status Registers (Continued)**

Register Name	Address	Bit	Description	R/W	Default
Video_Control	4Ch	15-5	Reserved. Set these bits to zero when writing to 4Ch.	–	–
	4Ch	4	10FID_F_pulse - set this bit HIGH to stretch the 10FID pulse duration from 1 line to 1 field. Reference: <a href="#">Section 3.8.1 on page 67</a>	R/W	0
	4Ch	3-2	Reserved. Set these bits to zero when writing to 4Ch.	–	–
	4Ch	1	Host_VID_STD - set this bit HIGH to select the output video standard using register 4Dh instead of the external VID_STD[5:0] pins. The external VID_STD[5:0] pins will be ignored, but should not be left floating. Reference: <a href="#">Section 1.4 on page 20</a>	R/W	0
	4Ch	0	Reserved. Set this bit to zero when writing to 4Ch.	–	–
VID_STD[5:0]	4Dh	15-6	Reserved. Set these bits to zero when writing to 4Dh.	–	–
	4Dh	5-0	Replaces the external VID_STD[5:0] pins when VID_From_Host (bit 1 of address 4Ch) is HIGH. Reference: <a href="#">Section 1.4 on page 20</a>	R/W	00h
Clocks_Per_Line	4Eh	15-0	Contains the number of output video clock cycles per line for the selected output timing format. If VID_STD[5:0] = 62, this register may be set by the user when programming custom output timing signals. Otherwise, this register is read-only. Reference: <a href="#">Section 3.10 on page 74</a>	R/W	–
Clocks_Per_Hsync	4Fh	15-0	Contains the number of output video clock cycles in the active H Sync interval for the selected output timing format. If VID_STD[5:0] = 62, this register may be set by the user when programming custom output timing signals. Otherwise, this register is read-only. Reference: <a href="#">Section 3.10 on page 74</a>	R/W	–
Hsync_To_SAV	50h	15-0	Contains the number of output video clock cycles from the start of H Sync to the start of active video for the selected output timing format. If VID_STD[5:0] = 62, this register may be set by the user when programming custom output timing signals. Otherwise, this register is read-only. Reference: <a href="#">Section 3.10 on page 74</a>	R/W	–
Hsync_To_EAV	51h	15-0	Contains the number of output video clock cycles from the start of H Sync to the end of active video for the selected output timing format. If VID_STD[5:0] = 62, this register may be set by the user when programming custom output timing signals. Otherwise, this register is read-only. Reference: <a href="#">Section 3.10 on page 74</a>	R/W	–

**Table 3-13: Configuration and Status Registers (Continued)**

Register Name	Address	Bit	Description	R/W	Default
Lines_Per_Field	52h	15-0	<p>Contains the number of lines per field for the selected output timing format.</p> <p>This register is 15.1 encoded (i.e. bit 0 represents 0.5 when set HIGH and 0 when set LOW).</p> <p>If VID_STD[5:0] = 62, this register may be set by the user when programming custom output timing signals. Otherwise, this register is read-only.</p> <p>NOTE: When bit 0 of this register is programmed HIGH, the device assumes an interlaced output. Otherwise it assumes a progressive output. For example, programming '262.5'd will result in an interlaced output standard with 525 lines per frame. Programming '525'd will result in a progressive output with 525 lines per frame.</p> <p>Reference: <a href="#">Section 3.10 on page 74</a></p>	R/W	–
Lines_Per_Vsync	53h	15-0	<p>Contains the number of lines per active V Sync interval for the selected output timing format.</p> <p>This register is 15.1 encoded (i.e. bit 0 represents '0.5' when set HIGH and '0' when set LOW).</p> <p>If VID_STD[5:0] = 62, this register may be set by the user when programming custom output timing signals. Otherwise, this register is read-only.</p> <p>Reference: <a href="#">Section 3.10 on page 74</a></p>	R/W	–
Vsync_To_First_Active_Line	54h	15-0	<p>Contains the number of lines from the start of V Sync to the start of active video for the selected output timing format.</p> <p>This register is 15.1 encoded (i.e. bit 0 represents '0.5' when set HIGH and '0' when set LOW).</p> <p>If VID_STD[5:0] = 62, this register may be set by the user when programming custom output timing signals. Otherwise, this register is read-only.</p> <p>NOTE1: The value programmed in this register will be increased by 1 by the device such that V Blanking signal generated will be one line longer than programmed.</p> <p>NOTE2: For the pre-programmed output video standards 3, 5, and 7, the value contained in this register is incorrectly reported as 17 lines, although the actual timing produced is correct at 16 lines.</p> <p>Reference: <a href="#">Section 3.10 on page 74</a></p>	R/W	–

**Table 3-13: Configuration and Status Registers (Continued)**

Register Name	Address	Bit	Description	R/W	Default
Vsync_To_Last_Active_Line	55h	15-0	<p>Contains the number of lines from the start of V Sync to the end of active video for the selected output timing format.</p> <p>This register is 15.1 encoded (i.e. bit 0 represents '0.5' when set HIGH and '0' when set LOW).</p> <p>If VID_STD[5:0] = 62, this register may be set by the user when programming custom output timing signals. Otherwise, this register is read-only.</p> <p>NOTE: The user cannot specify a custom vertical blanking signal to end in the middle of a line. If this occurs, the device will automatically adjust the timing of the signal to fall at the beginning of the next line.</p> <p>Reference: <a href="#">Section 3.10 on page 74</a></p>	R/W	–

**Table 3-13: Configuration and Status Registers (Continued)**

Register Name	Address	Bit	Description	R/W	Default
Polarity	56h	15-10	Reserved. Set these bits to zero when writing to 56h.	–	–
	56h	9	AFS (GS4911B only)- set this bit HIGH to invert the polarity of the AFS timing output signal. By default, the AFS signal is HIGH for the duration of the first line of the n'th video frame to indicate that the ACLK dividers have been reset at the start of line 1 of that frame. NOTE: The GS4910B does not generate an AFS pulse and will ignore the setting of this bit. Reference: <a href="#">Table 1-3</a>	R/W	0
	56h	8	10FID - set this bit HIGH to invert the polarity of the 10FID timing output signal. By default, the 10FID signal will go HIGH for one line at the start of the 10-field sequence. Reference: <a href="#">Table 1-3</a>	R/W	0
	56h	7	DE - set this bit HIGH to invert the polarity of the DE timing output signal. By default, the DE signal will be HIGH whenever pixel information is to be displayed on the display device Reference: <a href="#">Table 1-3</a>	R/W	0
	56h	6	Reserved. Set this bit to zero when writing to 56h.	–	–
	56h	5	F_Digital - set this bit HIGH to invert the polarity of the F Digital timing output signal. By default, the F Digital signal will be LOW for the entire period of field 1. Reference: <a href="#">Table 1-3</a>	R/W	0
	56h	4	F_Sync - set this bit HIGH to invert the polarity of the F Sync timing output signal. By default, the F Sync signal will be HIGH for the entire period of field 1. Reference: <a href="#">Table 1-3</a>	R/W	0
	56h	3	V_Blanking - set this bit HIGH to invert the polarity of the V Blanking timing output signal. By default, the V Blanking signal will be LOW for the portion of the field/frame containing valid video data. Reference: <a href="#">Table 1-3</a>	R/W	0

**Table 3-13: Configuration and Status Registers (Continued)**

Register Name	Address	Bit	Description	R/W	Default
	56h	2	V_Sync - set this bit HIGH to invert the polarity of the V Sync timing output signal. By default, the V Sync signal is active LOW. Reference: <a href="#">Table 1-3</a>	R/W	0
	56h	1	H_Blanking - set this bit HIGH to invert the polarity of the H Blanking timing output signal. By default, the H Blanking signal will be LOW for the portion of the video line containing valid video samples. Reference: <a href="#">Table 1-3</a>	R/W	0
	56h	0	H_Sync - set this bit HIGH to invert the polarity of the H Sync timing output signal. By default, the H Sync signal is active LOW. Reference: <a href="#">Table 1-3</a>	R/W	0
H_Start_1	57h	15-0	The value programmed in this register indicates the pixel start point for the leading edge of the user-programmed H Sync signal USER1_H. NOTE: The value programmed in this register must be less than the value programmed in H_Stop_1. Reference: <a href="#">Section 3.8.3 on page 69</a>	R/W	0
H_Stop_1	58h	15-0	The value programmed in this register indicates the pixel end point for the trailing edge of the user-programmed H Sync signal USER1_H. NOTE: The value programmed in this register must not exceed the maximum number of clock periods per line of the outgoing standard. Reference: <a href="#">Section 3.8.3 on page 69</a>	R/W	0
V_Start_1	59h	15	Reserved. Set this bit to zero when writing to 59h.	–	–
	59h	14-0	The value programmed in this register indicates the start line number of the leading edge of the user-programmed V Sync signal USER1_V. For interlaced output standards, this value corresponds to the odd field number. NOTE: The value programmed in this register must be less than the value programmed in V_Stop_1. Reference: <a href="#">Section 3.8.3 on page 69</a>	R/W	0
V_Stop_1	5Ah	15	Reserved. Set this bit to zero when writing to 5Ah.	–	–
	5Ah	14-0	The value programmed in this register indicates the end line number of the trailing edge of the user-programmed V Sync signal USER1_V. For interlaced output standards, this value corresponds to the odd field number. NOTE: The value programmed in this register must not exceed the maximum number of lines per field of the outgoing standard. Reference: <a href="#">Section 3.8.3 on page 69</a>	R/W	0

**Table 3-13: Configuration and Status Registers (Continued)**

Register Name	Address	Bit	Description	R/W	Default
Operator_Polarity_1	5Bh	15-4	Reserved. Set these bits to zero when writing to 5Bh.	–	–
	5Bh	3	Polarity_1 - Use this bit to invert the polarity of the final USER1 signal. By default, the polarity of the user programmed signals is active LOW. The polarity may be switched to active HIGH by setting this bit LOW. Reference: <a href="#">Section 3.8.3 on page 69</a>	R/W	1
	5Bh	2	AND_1 - logical operator: USER1_H AND USER1_V Set this bit HIGH to output a signal that is only active when both USER1_H and USER1_V are active. When this bit is HIGH, bit 1 and bit 0 of this register will be ignored. Reference: <a href="#">Section 3.8.3 on page 69</a>	R/W	0
	5Bh	1	OR_1 - logical operator: USER1_H OR USER1_V Set this bit HIGH to output a signal that is active whenever USER1_H or USER1_V are active. When this bit is HIGH bit 0 of this register will be ignored. Reference: <a href="#">Section 3.8.3 on page 69</a>	R/W	0
	5Bh	0	XOR_1 - logical operator: USER1_H XOR USER1_V Set this bit HIGH to output a signal with the following attributes: Signal becomes active when either USER1_H or USER1_V is active. Signal is inactive when USER1_H and USER1_V are both active or both inactive. Reference: <a href="#">Section 3.8.3 on page 69</a>	R/W	0
H_Start_2	5Ch	15-0	The value programmed in this register indicates the pixel start point for the leading edge of the user-programmed H Sync signal USER2_H. NOTE: The value programmed in this register must be less than the value programmed in H_Stop_2 Reference: <a href="#">Section 3.8.3 on page 69</a>	R/W	0
H_Stop_2	5Dh	15-0	The value programmed in this register indicates the pixel end point for the trailing edge of the user-programmed H Sync signal USER2_H. NOTE: The value programmed in this register must not exceed the maximum number of clock periods per line of the outgoing standard. Reference: <a href="#">Section 3.8.3 on page 69</a>	R/W	0



**Table 3-13: Configuration and Status Registers (Continued)**

Register Name	Address	Bit	Description	R/W	Default
V_Start_2	5Eh	15	Reserved. Set this bit to zero when writing to 5Eh.	–	–
	5Eh	14-0	The value programmed in this register indicates the start line number of the leading edge of the user-programmed V Sync signal USER2_V. For interlaced output standards, this value corresponds to the odd field line number.  NOTE: The value programmed in this register must be less than the value programmed in V_Stop_2. Reference: <a href="#">Section 3.8.3 on page 69</a>	R/W	0
V_Stop_2	5Fh	15	Reserved. Set this bit to zero when writing to 5Fh.	–	–
	5Fh	14-0	The value programmed in this register indicates the end line number of the trailing edge of the user-programmed V Sync signal USER2_V. For interlaced output standards, this value corresponds to the odd field line number.  NOTE: The value programmed in this register must not exceed the maximum number of lines per field of the outgoing standard. Reference: <a href="#">Section 3.8.3 on page 69</a>	R/W	0
Operator_Polarity_2	60h	15-4	Reserved. Set these bits to zero when writing to 60h.	–	–
	60h	3	Polarity_2 - Use this bit to invert the polarity of the final USER2 signal.  By default, the polarity of the user programmed signals is active LOW. The polarity may be switched to active HIGH by setting this bit LOW. Reference: <a href="#">Section 3.8.3 on page 69</a>	R/W	1
	60h	2	AND_2 - logical operator: USER2_H AND USER2_V  Set this bit HIGH to output a signal that is only active when both USER2_H and USER2_V are active. When this bit is HIGH, bit 1 and bit 0 of this register will be ignored. Reference: <a href="#">Section 3.8.3 on page 69</a>	R/W	0
	60h	1	OR_2 - logical operator: USER2_H OR USER2_V  Set this bit HIGH to output a signal that is active whenever USER2_H or USER2_V are active. When this bit is HIGH bit 0 of this register will be ignored. Reference: <a href="#">Section 3.8.3 on page 69</a>	R/W	0
	60h	0	XOR_2 - logical operator: USER2_H XOR USER2_V  Set this bit HIGH to output a signal with the following attributes: Signal becomes active when either USER2_H or USER2_V is active. Signal is inactive when USER2_H and USER2_V are both active or both inactive. Reference: <a href="#">Section 3.8.3 on page 69</a>	R/W	0

**Table 3-13: Configuration and Status Registers (Continued)**

Register Name	Address	Bit	Description	R/W	Default
H_Start_3	61h	15-0	The value programmed in this register indicates the pixel start point for the leading edge of the user-programmed H Sync signal USER3_H. NOTE: The value programmed in this register must be less than the value programmed in H_Stop_3. Reference: <a href="#">Section 3.8.3 on page 69</a>	R/W	0
H_Stop_3	62h	15-0	The value programmed in this register indicates the pixel end point for the trailing edge of the user-programmed H Sync signal USER3_H. NOTE: The value programmed in this register must not exceed the maximum number of clock periods per line of the outgoing standard. Reference: <a href="#">Section 3.8.3 on page 69</a>	R/W	0
V_Start_3	63h	15	Reserved. Set this bit to zero when writing to 63h.	–	–
	63h	14-0	The value programmed in this register indicates the start line number of the leading edge of the user-programmed V Sync signal USER3_V. For interlaced output standards, this value corresponds to the odd field line number. NOTE: The value programmed in this register must be less than the value programmed in V_Stop_3. Reference: <a href="#">Section 3.8.3 on page 69</a>	R/W	0
V_Stop_3	64h	15	Reserved. Set this bit to zero when writing to 64h.	–	–
	64h	14-0	The value programmed in this register indicates the end line number of the trailing edge of the user-programmed V Sync signal USER3_V. For interlaced output standards, this value corresponds to the odd field line number. NOTE: The value programmed in this register must not exceed the maximum number of lines per field of the outgoing standard. Reference: <a href="#">Section 3.8.3 on page 69</a>	R/W	0

**Table 3-13: Configuration and Status Registers (Continued)**

Register Name	Address	Bit	Description	R/W	Default
Operator_Polarity_3	65h	15-4	Reserved. Set these bits to zero when writing to 65h.	–	–
	65h	3	Polarity_3 - Use this bit to invert the polarity of the final USER3 signal. By default, the polarity of the user programmed signals is active LOW. The polarity may be switched to active HIGH by setting this bit LOW. Reference: <a href="#">Section 3.8.3 on page 69</a>	R/W	1
	65h	2	AND_3 - logical operator: USER3_H AND USER3_V Set this bit HIGH to output a signal that is only active when both USER3_H and USER3_V are active. When this bit is HIGH, bit 1 and bit 0 of this register will be ignored. Reference: <a href="#">Section 3.8.3 on page 69</a>	R/W	0
	65h	1	OR_3 - logical operator: USER3_H OR USER3_V Set this bit HIGH to output a signal that is active whenever USER3_H or USER3_V are active. When this bit is HIGH bit 0 of this register will be ignored. Reference: <a href="#">Section 3.8.3 on page 69</a>	R/W	0
	65h	0	XOR_3 - logical operator: USER3_H XOR USER3_V Set this bit HIGH to output a signal with the following attributes: Signal becomes active when either USER3_H or USER3_V is active. Signal is inactive when USER3_H and USER3_V are both active or both inactive. Reference: <a href="#">Section 3.8.3 on page 69</a>	R/W	0
H_Start_4	66h	15-0	The value programmed in this register indicates the pixel start point for the leading edge of the user-programmed H Sync signal USER4_H. NOTE: The value programmed in this register must be less than the value programmed in H_Stop_4. Reference: <a href="#">Section 3.8.3</a>	R/W	0
H_Stop_4	67h	15-0	The value programmed in this register indicates the pixel end point for the trailing edge of the user-programmed H Sync signal USER4_H. NOTE: The value programmed in this register must not exceed the maximum number of clock periods per line of the outgoing standard. Reference: <a href="#">Section 3.8.3 on page 69</a>	R/W	0

**Table 3-13: Configuration and Status Registers (Continued)**

Register Name	Address	Bit	Description	R/W	Default
V_Start_4	68h	15	Reserved. Set this bit to zero when writing to 68h.	–	–
	68h	14-0	The value programmed in this register indicates the start line number of the leading edge of the user-programmed V Sync signal USER4_V. For interlaced output standards, this value corresponds to the odd field line number.  NOTE: The value programmed in this register must be less than the value programmed in V_Stop_4. Reference: <a href="#">Section 3.8.3 on page 69</a>	R/W	0
V_Stop_4	69h	15	Reserved. Set this bit to zero when writing to 69h.	–	–
	69h	14-0	The value programmed in this register indicates the end line number of the trailing edge of the user-programmed V Sync signal USER4_V. For interlaced output standards, this value corresponds to the odd field line number.  NOTE: The value programmed in this register must not exceed the maximum number of lines per field of the outgoing standard. Reference: <a href="#">Section 3.8.3 on page 69</a>	R/W	0
Operator_Polarity_4	6Ah	15-4	Reserved. Set these bits to zero when writing to 6Ah.	–	–
	6Ah	3	Polarity_4 - Use this bit to invert the polarity of the final USER4 signal.  By default, the polarity of the user programmed signals is active LOW. The polarity may be switched to active HIGH by setting this bit LOW. Reference: <a href="#">Section 3.8.3 on page 69</a>	R/W	1
	6Ah	2	AND_4 - logical operator: USER4_H AND USER4_V  Set this bit HIGH to output a signal that is only active when both USER4_H and USER4_V are active. When this bit is HIGH, bit 1 and bit 0 of this register will be ignored. Reference: <a href="#">Section 3.8.3 on page 69</a>	R/W	0
	6Ah	1	OR_4 - logical operator: USER4_H OR USER4_V  Set this bit HIGH to output a signal that is active whenever USER4_H or USER4_V are active. When this bit is HIGH bit 0 of this register will be ignored. Reference: <a href="#">Section 3.8.3 on page 69</a>	R/W	0
	6Ah	0	XOR_4 - logical operator: USER4_H XOR USER4_V  Set this bit HIGH to output a signal with the following attributes: Signal becomes active when either USER4_H or USER4_V is active. Signal is inactive when USER4_H and USER4_V are both active or both inactive. Reference: <a href="#">Section 3.8.3 on page 69</a>	R/W	0

**Table 3-13: Configuration and Status Registers (Continued)**

Register Name	Address	Bit	Description	R/W	Default
Ext_Audio_Mode	81h	15-0	<p>Set this register to 20C1h to enable the Extended Audio Mode of the device.</p> <p>To fully enable this mode, VID_STD[5:0] must be set to 4d, and the F_Lock_Mask and V_Lock_Mask bits [4:3] of register address 16h must be set to 1.</p> <p>NOTE: Once this register is programmed, it must be updated using bit 6 of register 16h.</p> <p>Reference: <a href="#">Section 3.11 on page 75</a></p>	R/W	0
Ln_Count_Reset	83h	15	<p>Toggle this bit to reset the line-based counters in the device.</p> <p>This is only required when locking the “f/1.001” HD output standards to the 525-line SD input reference standards, or vice-versa, AND:</p> <ol style="list-style-type: none"> <li>1. The reference has been removed and subsequently re-applied. In this case, the user should wait until the reference has been re-detected by the device, which may take up to 4 frames. See <a href="#">Section 3.5.3 on page 47</a>.</li> </ol> <p>OR</p> <ol style="list-style-type: none"> <li>2. The device is locked to blanking signals from a deserializer, and the SDI input to the deserializer has been switched upstream from the system. See <a href="#">Section 3.6.5 on page 60</a>.</li> </ol>	R/W	0
	83h	14-0	Reserved. Set these bits to zero when writing to 83h.	–	–

### 3.13 JTAG

When the JTAG/ $\overline{\text{HOST}}$  input pin of the GS4911B/GS4910B is set HIGH, the host interface port will be configured for JTAG test operation. In this mode, pins 57 through 60 become TCLK, TDI, TDO, and TMS. In addition, the  $\overline{\text{RESET}}$  pin will operate as the test reset pin.

Boundary scan testing using the JTAG interface will be enabled in this mode.

There are two methods in which JTAG can be used on the GS4911B/GS4910B:

1. As a stand-alone JTAG interface to be used at in-circuit ATE (Automatic Test Equipment) during PCB assembly; or
2. Under control of the host for applications such as system power on self tests.

When the JTAG tests are applied by ATE, care must be taken to disable any other devices driving the digital I/O pins. If the tests are to be applied only at ATE, this can be accomplished with high-impedance buffers used in conjunction with the JTAG/ $\overline{\text{HOST}}$  input signal. This is shown in [Figure 3-19](#).

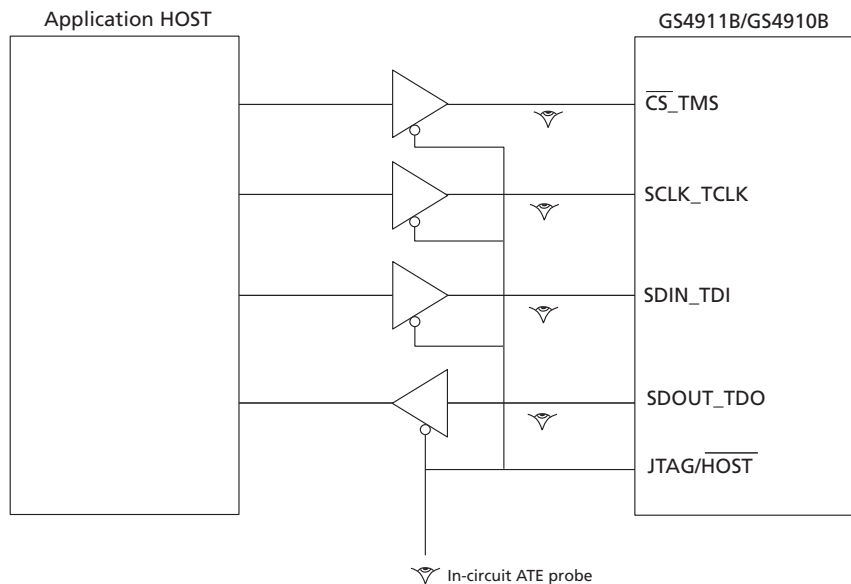

Figure 3-19: In-Circuit JTAG

Alternatively, if the test capabilities are to be used in the system, the host may still control the JTAG/ $\overline{\text{HOST}}$  input signal, but some means for tri-stating the host must exist in order to use the interface at ATE. This is represented in [Figure 3-20](#).

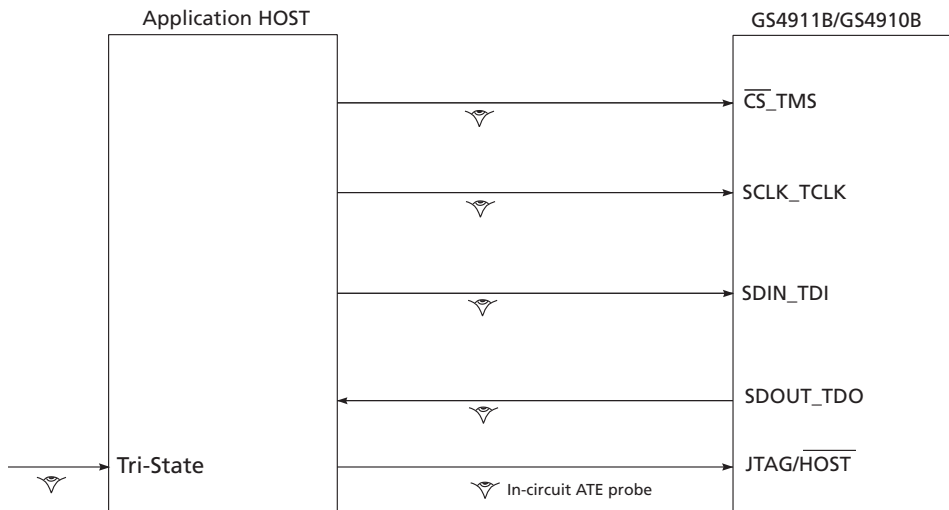

Figure 3-20: System JTAG

NOTE: When running boundary scan testing, the  $\text{TIMING\_OUT}_n$  pins should be set to high-impedance by setting  $\text{VID\_STDn}$  to 000h.

## 3.14 Device Power-Up

### 3.14.1 Power Supply Sequencing

The GS4911B/GS4910B has a recommended power supply sequence. To ensure correct power-up, the  $\text{ANALOG\_VDD}$  and  $\text{CORE\_VDD}$  power pins should be powered before  $\text{IO\_VDD}$ .

Device pins may be driven prior to power-up without causing damage.

## 3.15 Device Reset

In order to initialize operating conditions to their default states, the application layer must hold the  $\text{RESET}$  signal LOW during power up and for a minimum of 500us after the last supply has reached its operating voltage.

# 4. Application Reference Design

## 4.1 GS4911B Typical Application Circuit

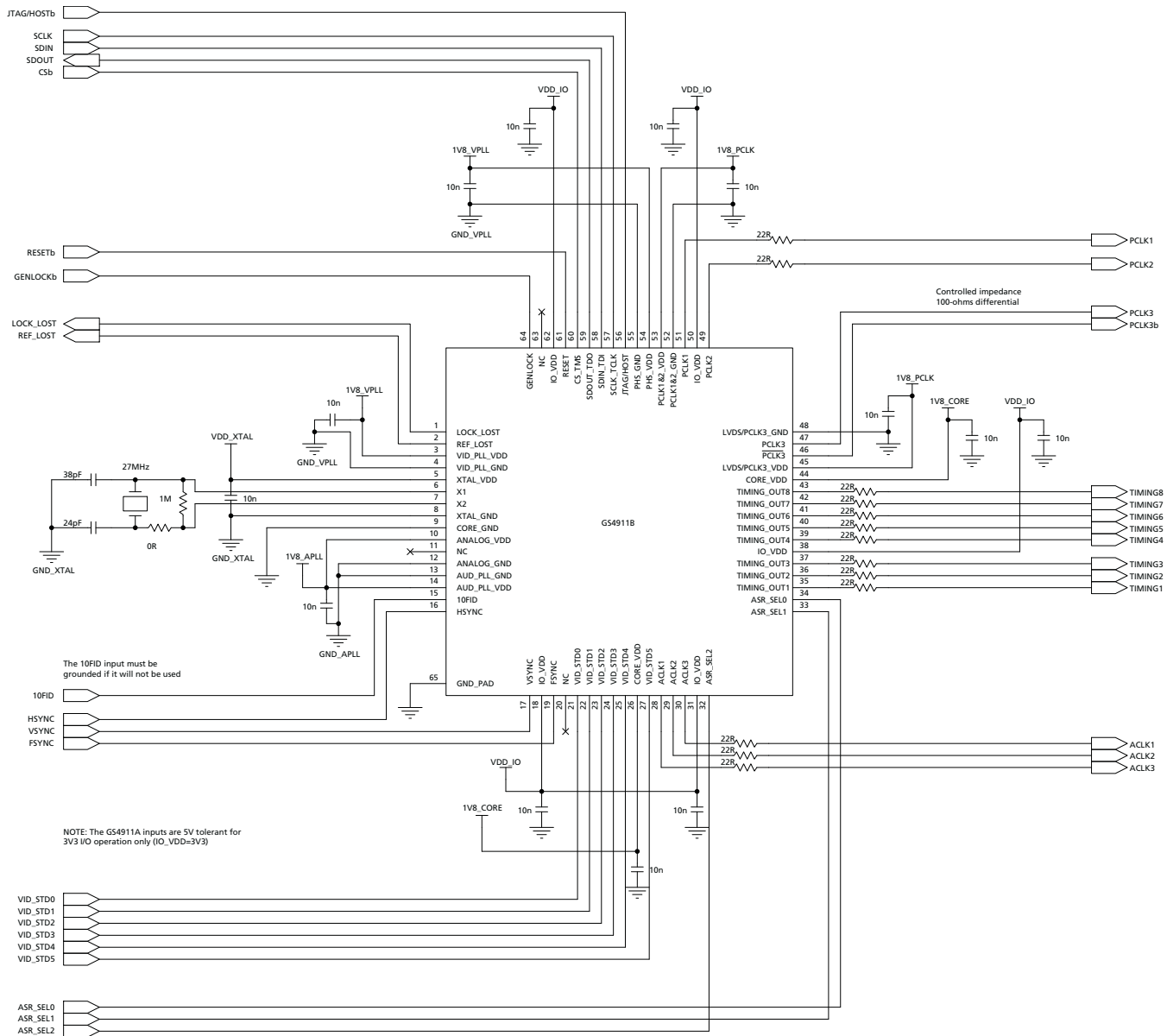

NOTE: For a solution with the lowest output jitter, the GS1531 or GS1532 serializers are recommended for use with the GS4911B/GS4910B.



## 4.2 GS4910B Typical Application Circuit

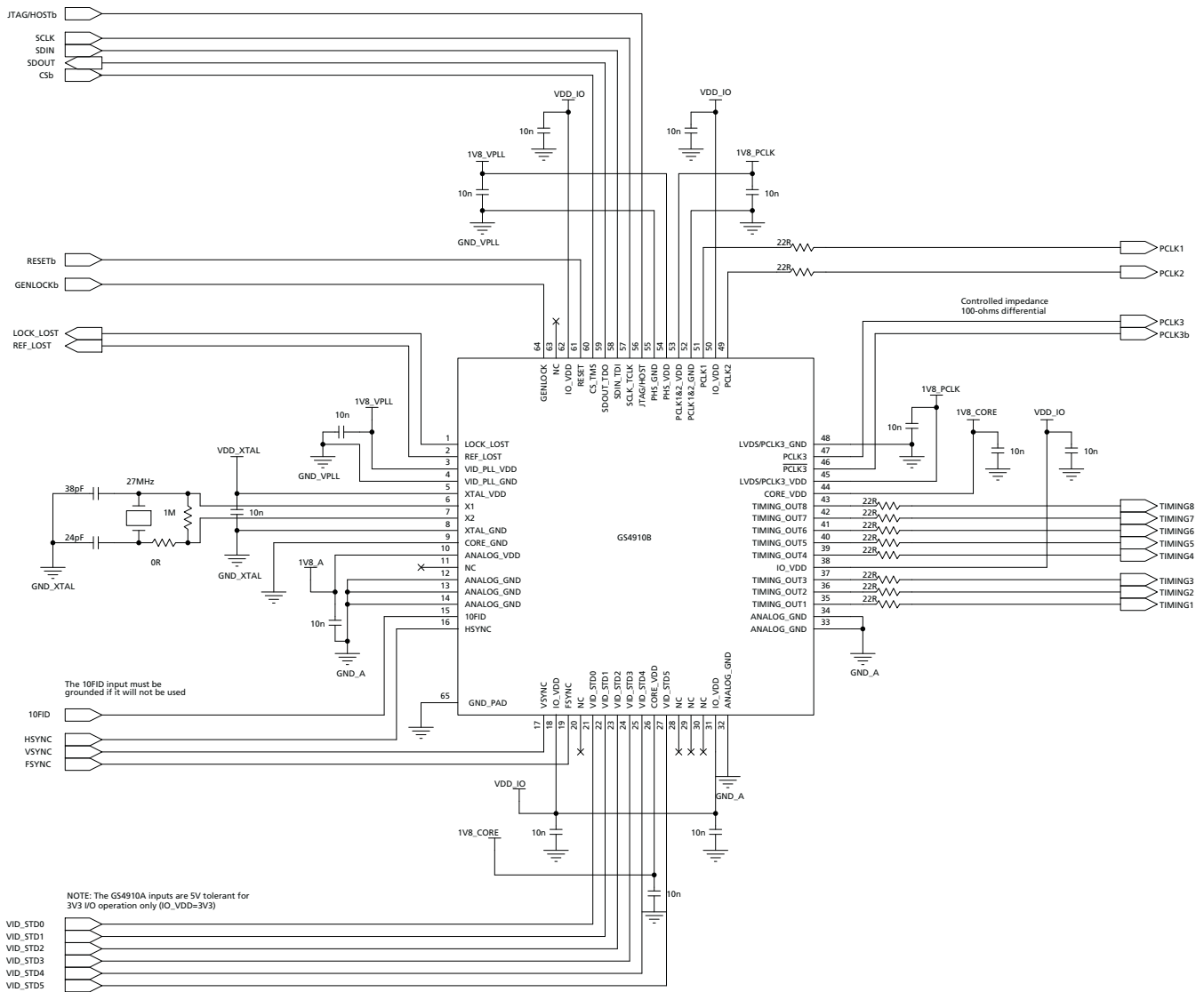

NOTE: For a solution with the lowest output jitter, the GS1531 or GS1532 serializers are recommended for use with the GS4911B/GS4910B.

# 5. References & Relevant Standards

**Table 5-1: References & Relevant Standards**

AES11-1997	Synchronization of Digital Audio Equipment in Studio Operations
SMPTE 125M-1995	Component Video Signal 4:2:2 – Bit-Parallel Digital Interface
SMPTE 170M-1999	Composite Analog Video Signal – NTSC for Studio Applications
SMPTE 244M-1995	System M/NTSC Composite Video Signals – Bit-Parallel Digital Interface
SMPTE 260M-1999	1125/60 High-Definition Production System – Digital Representation and Bit-Parallel Interface
SMPTE 267M-1995	Bit-Parallel Digital Interface – Component Video Signal 4:2:2 16x9 Aspect Ratio
SMPTE 274M-1998	1920 x 1080 Scanning and Analog and Parallel Digital Interfaces for Multiple Picture Rates
SMPTE 293M-1996	720 x 483 Active Line at 59.94-Hz Progressive Scan Production – Digital Representation
SMPTE 296M-1997	1280 x 720 Scanning, Analog and Digital Representation an Analog Interface
SMPTE 318M-1999	Synchronization of 59.94- or 50-Hz Related Video and Audio Systems in Analog and Digital Areas – Reference Signals
SMPTE 347M-2001	540 Mb/s Serial Digital Interface – Source Image Format Mapping
SMPTE RP 164-1996	Location of Vertical Interval Time Code
SMPTE RP 168-1993	Definition of Vertical Interval Switching Point for Synchronous Video Switching
SMPTE RP 211-2000	Implementation of 24P, 25P and 30P Segmented Frames for 1920 x 1080 Production Format
ITU-R BT.601-5	Studio Encoding Parameters of Digital Television for Standard 4:3 and Wide-screen 16:9 Aspect Ratios
ITU-R BT.709-4	Parameter Values for the HDTV Standards for Production and International Program Exchange ITU-R BT.799.3 Interface for Digital Component Video Signals in 525-line and 625-line Television Systems Operating at the 4:4:4 Level of Recommendation ITU-R BT.601 (PART A)
ITU-R BT.1358	Studio Parameters of 625 and 525 Line Progressive Scan Television Systems
VESA Monitor Timing Specifications	VESA and industry Standards and Guidelines for Computer Display Monitor Timing – Version 1.0, Revision 0.8 (Adoption Date: September 17, 1998)

# 6. Package & Ordering Information

## 6.1 Package Dimensions

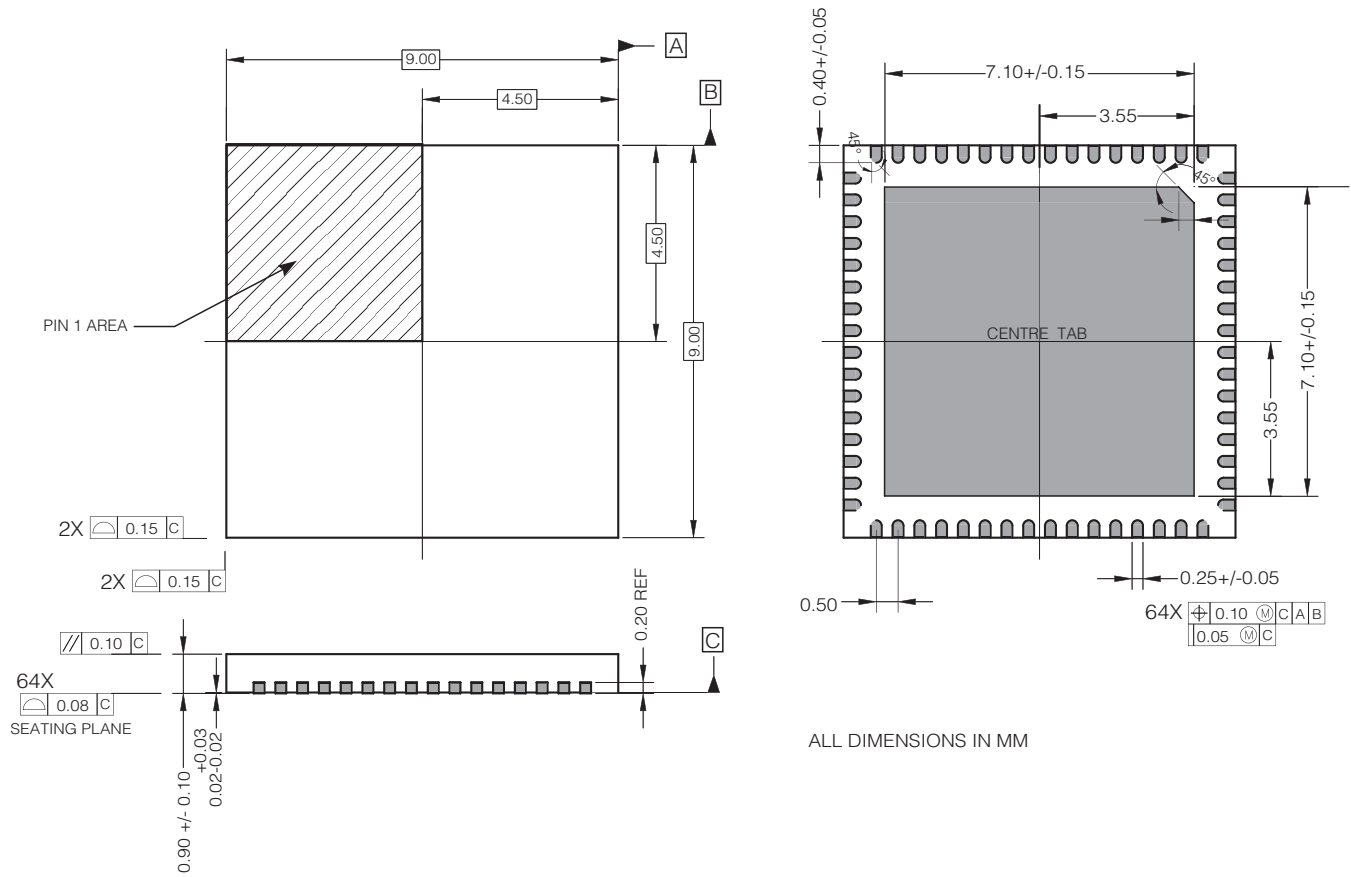

## 6.2 Solder Reflow Profiles

The device is manufactured with Matte-Sn terminations and is compatible with both standard eutectic and Pb-free solder reflow profiles. MSL qualification was performed using the maximum Pb-free reflow profile shown in Figure 6-1. The recommended standard Pb reflow profile is shown in Figure 6-2.

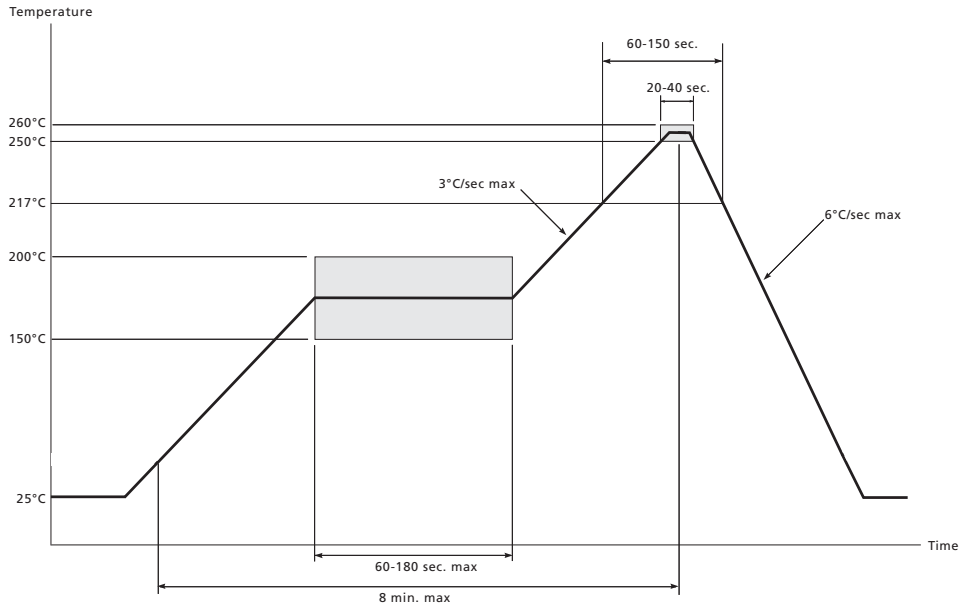

Figure 6-1: Maximum Pb-free Solder Reflow Profile (preferred)

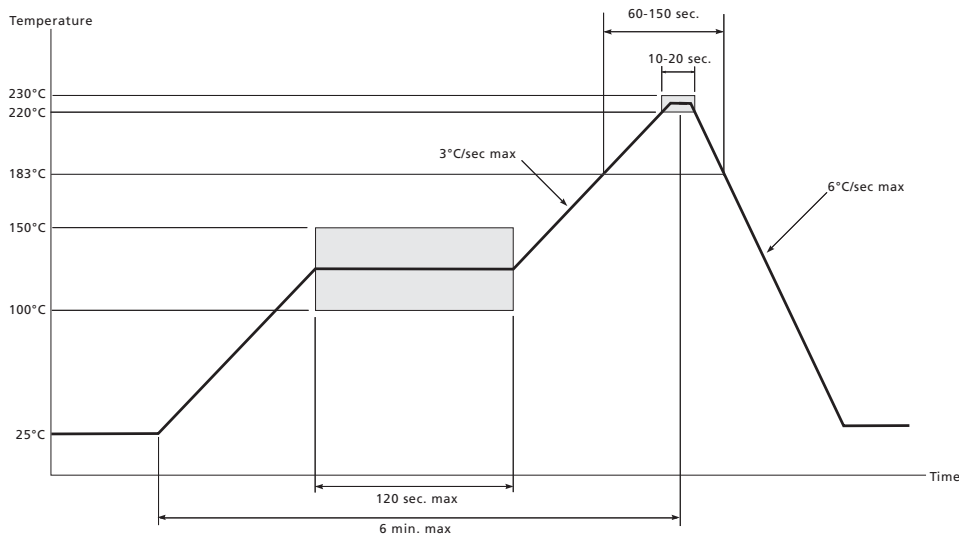
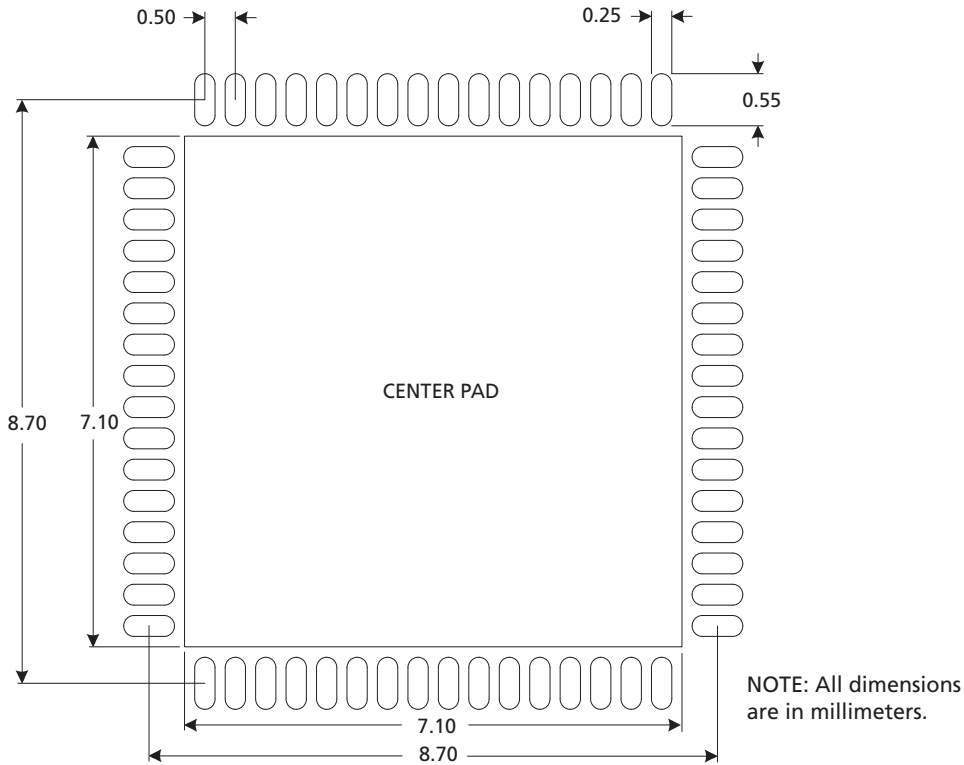

Figure 6-2: Standard Pb Solder Reflow Profile

## 6.3 Recommended PCB Footprint



The center pad of the PCB footprint should be connected to the ground plane by a minimum of 36 vias.

NOTE: Suggested dimensions only. Final dimensions should conform to customer design rules and process optimizations.

## 6.4 Packaging Data

Parameter	Value
Package Type	9mm x 9mm 64-pin QFN
Moisture Sensitivity Level	3
Junction to Case Thermal Resistance, $\theta_{j-c}$	9.3°C/W
Junction to Air Thermal Resistance, $\theta_{j-a}$ (at zero airflow)	24.6°C/W
Psi, $\psi$	0.2°C/W
Pb-free and RoHS Compliant	Yes

## 6.5 Ordering Information

Part	Video Clocks	Graphics Clocks	Audio Clocks	Full Programmability	Max PCLK Rate
GS4911B	√	√	√	√	165MHz
GS4910B	√	√	–	√	165MHz

Part Number	Package	Temperature Range
GS4911BCNE3	Pb-free 64-pin QFN	0°C to 70°C
GS4910BCNE3	Pb-free 64-pin QFN	0°C to 70°C

---

**DOCUMENT IDENTIFICATION  
DATA SHEET**

The product is in production. Gennum reserves the right to make changes to the product at any time without notice to improve reliability, function or design, in order to provide the best product possible.

**CAUTION**

ELECTROSTATIC SENSITIVE DEVICES  
DO NOT OPEN PACKAGES OR HANDLE EXCEPT AT A  
STATIC-FREE WORKSTATION



---

**GENNUM CORPORATE HEADQUARTERS**

4281 Harvester Road, Burlington, Ontario L7L 5M4 Canada

Phone: +1 (905) 632-2996

E-mail: [corporate@gennum.com](mailto:corporate@gennum.com)

Fax: +1 (905) 632-2055

[www.gennum.com](http://www.gennum.com)

---

**OTTAWA**

232 Herzberg Road, Suite 101  
Kanata, Ontario K2K 2A1  
Canada

Phone: +1 (613) 270-0458

Fax: +1 (613) 270-0429

**CALGARY**

3553 - 31st St. N.W., Suite 210  
Calgary, Alberta T2L 2K7  
Canada

Phone: +1 (403) 284-2672

**UNITED KINGDOM**

North Building, Walden Court  
Parsonage Lane,  
Bishop's Stortford Hertfordshire, CM23 5DB  
United Kingdom

Phone: +44 1279 714170

Fax: +44 1279 714171

**INDIA**

#208(A), Nirmala Plaza,  
Airport Road, Forest Park Square  
Bhubaneswar 751009  
India

Phone: +91 (674) 653-4815

Fax: +91 (674) 259-5733

**SNOWBUSH IP - A DIVISION OF GENNUM**

439 University Ave. Suite 1700  
Toronto, Ontario M5G 1Y8  
Canada

Phone: +1 (416) 925-5643

Fax: +1 (416) 925-0581

E-mail: [sales@snowbush.com](mailto:sales@snowbush.com)

Web Site: <http://www.snowbush.com>

**MEXICO**

288-A Paseo de Maravillas  
Jesus Ma., Aguascalientes  
Mexico 20900

Phone: +1 (416) 848-0328

**JAPAN KK**

Shinjuku Green Tower Building 27F  
6-14-1, Nishi Shinjuku  
Shinjuku-ku, Tokyo, 160-0023  
Japan

Phone: +81 (03) 3349-5501

Fax: +81 (03) 3349-5505

E-mail: [gennum-japan@gennum.com](mailto:gennum-japan@gennum.com)

Web Site: <http://www.gennum.co.jp>

**TAIWAN**

6F-4, No.51, Sec.2, Keelung Rd.  
Sinyi District, Taipei City 11502  
Taiwan R.O.C.

Phone: (886) 2-8732-8879

Fax: (886) 2-8732-8870

E-mail: [gennum-taiwan@gennum.com](mailto:gennum-taiwan@gennum.com)

**GERMANY**

Hainbuchenstraße 2  
80935 Muenchen (Munich), Germany

Phone: +49-89-35831696

Fax: +49-89-35804653

E-mail: [gennum-germany@gennum.com](mailto:gennum-germany@gennum.com)

**NORTH AMERICA WESTERN REGION**

Bayshore Plaza  
2107 N 1st Street, Suite #300  
San Jose, CA 95131  
United States

Phone: +1 (408) 392-9454

Fax: +1 (408) 392-9427

E-mail: [naw\\_sales@gennum.com](mailto:naw_sales@gennum.com)

**NORTH AMERICA EASTERN REGION**

4281 Harvester Road  
Burlington, Ontario L7L 5M4  
Canada

Phone: +1 (905) 632-2996

Fax: +1 (905) 632-2055

E-mail: [nae\\_sales@gennum.com](mailto:nae_sales@gennum.com)

**KOREA**

8F Jinnex Lakeview Bldg.  
65-2, Bangidong, Songpagu  
Seoul, Korea 138-828

Phone: +82-2-414-2991

Fax: +82-2-414-2998

E-mail: [gennum-korea@gennum.com](mailto:gennum-korea@gennum.com)

---

Gennum Corporation assumes no liability for any errors or omissions in this document, or for the use of the circuits or devices described herein. The sale of the circuit or device described herein does not imply any patent license, and Gennum makes no representation that the circuit or device is free from patent infringement.

All other trademarks mentioned are the properties of their respective owners.

GENNUM and the Gennum logo are registered trademarks of Gennum Corporation.

© Copyright 2005 Gennum Corporation. All rights reserved.

[www.gennum.com](http://www.gennum.com)

## X-ON Electronics

Largest Supplier of Electrical and Electronic Components

*Click to view similar products for [Clock Generators & Support Products](#) category:*

*Click to view products by [Semtech](#) manufacturer:*

Other Similar products are found below :

[5P49V5901A748NLGI](#) [5P49V5901B680NLGI](#) [5P49V5901B744NLGI](#) [5P49V5929B502NLGI](#) [5P49V5935B520LTGI](#) [5V49EE903-116NLGI](#)  
[CV183-2TPAG](#) [82P33814ANLG/W](#) [8T49N004A-002NLGI](#) [8T49N004A-039NLGI](#) [9FGV0631CKLF](#) [9FGV0641AKLFT](#) [9LRS3197AKLF](#)  
[9UMS9633BFILF](#) [9VRS4450AKLF](#) [NB3N51132DTR2G](#) [8N3Q001EG-0035CDI](#) [932SQ426AKLF](#) [950810CGLF](#) [9DBV0531AKILF](#)  
[9DBV0741AKILF](#) [9FGV0641AKLF](#) [9UMS9633BKLF](#) [9VRS4420DKILF](#) [9VRS4420DKLF](#) [9VRS4420DKLFT](#) [CY25404ZXI226](#)  
[CY25422SXI-004](#) [5P49V5901B712NLGI](#) [NB3H5150-01MNTXG](#) [6INT61041NDG](#) [PL602-20-K52TC](#) [PL613-51QC](#) [8N3Q001FG-1114CDI](#)  
[9FGV0641AKILF](#) [ZL30314GKG2](#) [ZL30253LDG1](#) [ZL30251LDG1](#) [ZL30250LDG1](#) [ZL30169LDG1](#) [ZL30142GGG2](#) [9UMS9633BKILFT](#)  
[9FGV0631CKLFT](#) [9FGV0631CKILF](#) [5P49V5935B536LTGI](#) [PI6LC48P0101LIE](#) [DS1099U-ST+](#) [MAX24305EXG+](#) [PI6LC48H02-01LIE](#)  
[82P33814ANLG](#)