

## FEATURES

- HIGH CURRENT, SMALL SIZE (UP TO 8.6 AMPS)
- SURFACE MOUNTABLE CONSTRUCTION
- HIGH INDUCTANCE (UP TO 1000 $\mu$ H)
- TAPED AND REELED FOR AUTOMATIC INSERTION
- FOR USE IN DC/DC CONVERTERS

**RoHS Compliant**  
includes all homogeneous materials



\*See Part Number System for Details

## CHARACTERISTICS

Case Size	NPI16W	NPI31W	NPI34W	NPI52W
Inductance Range	1 ~ 1000 $\mu$ H	1.0 ~ 3300 $\mu$ H	10 ~ 1000 $\mu$ H	1 ~ 1000 $\mu$ H
Ambient Operating Temperature Range	-40°C ~ +85°C*			
Maximum Component Temperature (Ambient + Self-Heating)	+125°C*			
Temperature Rise at Irms	40°C max.			
Inductance Change at Isat	-10% typical			
Inductance Tolerance	20% (M)			
Resistance to Solder Heat	260°C for 10 seconds			

## DIMENSIONS (mm)

Series	A	B	C	D	E	F	G (Ref)	H (Ref)	I (Ref)
NPI16W	4.45 Max	6.60 Max	2.92 Max	1.02 $\pm$ 0.2	1.27 $\pm$ 0.2	4.32 $\pm$ 0.3	4.06	3.56	1.4
NPI31W	9.30 $\pm$ 0.2	12.80 $\pm$ 0.2	5.00 $\pm$ 0.3	2.40 $\pm$ 0.2	2.50 $\pm$ 0.2	7.60 $\pm$ 0.3	7.3	2.8	3
NPI34W	9.30 $\pm$ 0.2	12.80 $\pm$ 0.2	11.0 $\pm$ 0.5	2.40 $\pm$ 0.2	2.50 $\pm$ 0.2	7.60 $\pm$ 0.3	7.3	2.8	3
NPI52W	15.0 $\pm$ 0.3	18.40 $\pm$ 0.3	7.00 $\pm$ 0.5	2.40 $\pm$ 0.2	2.20 $\pm$ 0.2	13.30 $\pm$ 0.3	12.7	2.8	3

## PART NUMBER SYSTEM

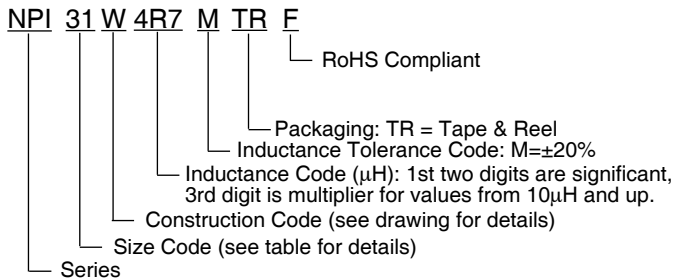

## CONSTRUCTION

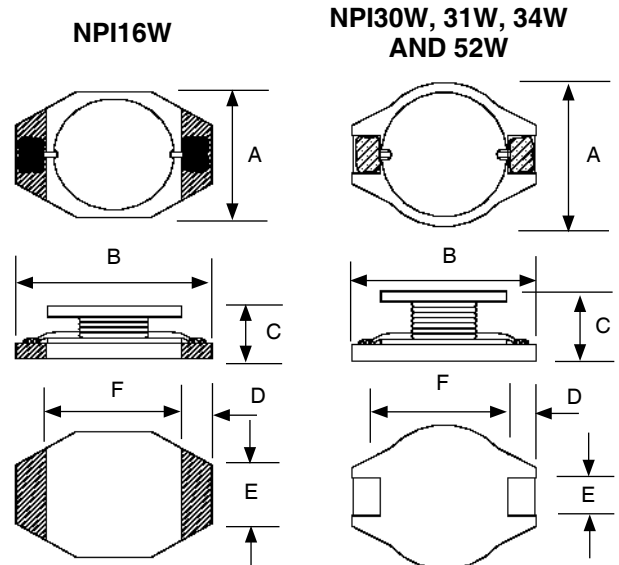

## LAND PATTERN

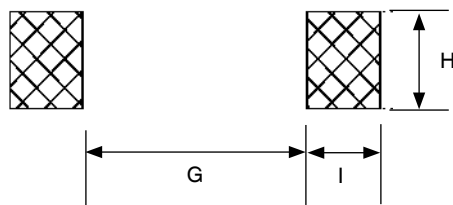

\*Specifications reflect recent product changes. For more information refer to PCN announcement [Link]

Part Number	STANDARD VALUES - CASE SIZE 16 (4.45 x 6.6 x 2.92mm)					Test Frequency
	Inductance Value (μH)	SRF (Typical) MHz	DC Resistance (Ω)	DC Current I <sub>rms</sub> (Amps)	DC Current I <sub>sat</sub> (Amps)	
NPI16W1R0MTRF	1.0 ± 20%	130	0.05	2.9	2.9	100KHz
NPI16W1R5MTRF	1.5 ± 20%	115	0.05	2.8	2.6	
NPI16W2R2MTRF	2.2 ± 20%	90	0.07	2.4	2.3	
NPI16W3R3MTRF	3.3 ± 20%	70	0.08	2.0	2.0	
NPI16W4R7MTRF	4.7 ± 20%	50	0.09	1.5	1.5	
NPI16W6R8MTRF	6.8 ± 20%	45	0.13	1.4	1.2	
NPI16W100MTRF	10 ± 20%	35	0.16	1.1	1.1	
NPI16W150MTRF	15 ± 20%	30	0.23	1.0	0.90	
NPI16W220MTRF	22 ± 20%	20	0.37	0.80	0.70	
NPI16W330MTRF	33 ± 20%	15	0.51	0.60	0.58	
NPI16W470MTRF	47 ± 20%	14	0.64	0.50	0.50	
NPI16W680MTRF	68 ± 20%	11	0.86	0.40	0.50	
NPI16W101MTRF	100 ± 20%	9.0	1.27	0.30	0.31	
NPI16W151MTRF	150 ± 20%	6.0	2.00	0.25	0.27	
NPI16W221MTRF	220 ± 20%	5.5	3.11	0.20	0.22	
NPI16W331MTRF	330 ± 20%	5.0	3.80	0.16	0.18	
NPI16W471MTRF	470 ± 20%	4.0	6.78	0.15	0.16	
NPI16W681MTRF	680 ± 20%	3.0	9.20	0.12	0.14	
NPI16W102MTRF	1000 ± 20%	2.0	13.8	0.07	0.10	

Maximum +40°C temperature rise at I<sub>rms</sub>. Typical -10% inductance change at I<sub>sat</sub>.

Part Number	STANDARD VALUES - CASE SIZE 31 (10.0 x 12.7 x 5.0mm)					Test Frequency
	Inductance Value (μH)	SRF (Typical) MHz	DC Resistance (Ω)	DC Current I <sub>rms</sub> (Amps)	DC Current I <sub>sat</sub> (Amps)	
NPI31W1R0MTRF	1.0 ± 20%	150	0.009	6.8	9.0	100KHz
NPI31W1R5MTRF	1.5 ± 20%	100	0.010	6.4	8.0	
NPI31W2R2MTRF	2.2 ± 20%	85	0.012	6.1	7.0	
NPI31W3R3MTRF	3.3 ± 20%	60	0.015	5.4	5.8	
NPI31W4R7MTRF	4.7 ± 20%	45	0.018	4.8	5.2	
NPI31W6R8MTRF	6.8 ± 20%	35	0.027	4.4	4.3	
NPI31W100MTRF	10 ± 20%	25	0.038	3.9	3.4	
NPI31W150MTRF	15 ± 20%	20	0.046	3.1	3.0	
NPI31W220MTRF	22 ± 20%	18	0.085	2.7	2.5	
NPI31W330MTRF	33 ± 20%	14	0.10	2.1	2.0	
NPI31W470MTRF	47 ± 20%	11	0.14	1.8	1.8	
NPI31W680MTRF	68 ± 20%	10	0.20	1.5	1.4	
NPI31W101MTRF	100 ± 20%	7.0	0.28	1.3	1.2	
NPI31W151MTRF	150 ± 20%	6.5	0.40	1.0	0.9	
NPI31W221MTRF	220 ± 20%	5.0	0.61	0.8	0.8	
NPI31W331MTRF	330 ± 20%	4.0	1.02	0.6	0.6	
NPI31W471MTRF	470 ± 20%	3.0	1.27	0.5	0.5	
NPI31W681MTRF	680 ± 20%	2.5	2.02	0.4	0.4	

**NPI31W values continue on next page**

Maximum +40°C temperature rise at I<sub>rms</sub>. Typical -10% inductance change at I<sub>sat</sub>.



Part Number	STANDARD VALUES - CASE SIZE 31 (10.0 x 12.7 x 5.0mm)					Test Frequency
	Inductance Value (µH)	SRF (Typical) MHz	DC Resistance (Ω)	DC Current Irms (Amps)	DC Current Isat (Amps)	
NPI31W102MTRF	1000 ± 20%	2.0	3.00	0.3	0.3	100KHz
NPI31W152MTRF	1500 ± 20%	1.3	4.49	0.27	0.29	
NPI31W222MTRF	2200 ± 20%	1.23	8.50	0.20	0.25	
NPI31W332MTRF	3300 ± 20%	0.87	11.20	0.17	0.19	

Maximum +40°C temperature rise at Irms. Typical -10% inductance change at Isat.

Part Number	STANDARD VALUES - CASE SIZE 34 (10.0 x 12.7 x 11mm)					Test Frequency
	Inductance Value (µH)	SRF (Typical) MHz	DC Resistance (Ω)	DC Current Irms (Amps)	DC Current Isat (Amps)	
NPI34W100MTRF	10 ± 20%	23	0.040	3.50	7.0	100KHz
NPI34W150MTRF	15 ± 20%	14	0.050	3.20	5.8	
NPI34W220MTRF	22 ± 20%	8.5	0.066	2.90	4.8	
NPI34W330MTRF	33 ± 20%	7.0	0.080	2.35	3.8	
NPI34W470MTRF	47 ± 20%	6.5	0.110	2.10	3.4	
NPI34W680MTRF	68 ± 20%	4.5	0.170	1.90	2.7	
NPI34W101MTRF	100 ± 20%	4.0	0.220	1.55	2.2	
NPI34W151MTRF	150 ± 20%	3.0	0.340	1.35	1.9	
NPI34W221MTRF	220 ± 20%	2.5	0.440	1.00	1.5	
NPI34W331MTRF	330 ± 20%	2.3	0.700	0.90	1.3	
NPI34W471MTRF	470 ± 20%	2.0	0.950	0.75	1.0	
NPI34W681MTRF	680 ± 20%	1.5	1.20	0.55	0.9	
NPI34W102MTRF	1000 ± 20%	1.3	2.00	0.50	0.7	

Maximum +40°C temperature rise at Irms. Typical -10% inductance change at Isat.

Part Number	STANDARD VALUES - CASE SIZE 52 (15.0 x 18.4 x 7.0mm)					Test Frequency
	Inductance Value (µH)	SRF (Typical) MHz	DC Resistance (Ω)	DC Current Irms (Amps)	DC Current Isat (Amps)	
NPI52W1R0MTRF	1.0 ± 20%	140	0.009	8.6	20	100KHz
NPI52W1R5MTRF	1.5 ± 20%	110	0.012	7.5	18	
NPI52W2R2MTRF	2.2 ± 20%	75	0.014	7.1	16	
NPI52W3R3MTRF	3.3 ± 20%	70	0.018	6.2	14	
NPI52W4R7MTRF	4.7 ± 20%	55	0.019	5.8	13	
NPI52W5R6MTRF	5.6 ± 20%	45	0.020	5.3	12	
NPI52W8R2MTRF	8.2 ± 20%	23	0.025	4.7	11	
NPI52W100MTRF	10 ± 20%	21	0.031	4.3	10	
NPI52W150MTRF	15 ± 20%	16	0.036	4.0	8.0	
NPI52W220MTRF	22 ± 20%	13	0.047	3.5	7.0	
NPI52W330MTRF	33 ± 20%	11	0.066	3.0	5.5	

**NPI52W values continue on next page**

Maximum +40°C temperature rise at Irms. Typical -10% inductance change at Isat.



Part Number	STANDARD VALUES - CASE SIZE 52 (15.0 x 18.4 x 7.0mm)					Test Frequency
	Inductance Value (μH)	SRF (Typical) MHz	DC Resistance (Ω)	DC Current Irms (Amps)	DC Current Isat (Amps)	
NPI52W470MTRF	47 ± 20%	9.0	0.086	2.6	4.5	100KHz
NPI52W680MTRF	68 ± 20%	6.5	0.13	2.3	3.5	
NPI52W101MTRF	100 ± 20%	5.7	0.19	1.8	3.0	
NPI52W151MTRF	150 ± 20%	4.5	0.25	1.5	2.6	
NPI52W221MTRF	220 ± 20%	3.7	0.38	1.2	2.4	
NPI52W331MTRF	330 ± 20%	3.0	0.56	1.0	1.9	
NPI52W471MTRF	470 ± 20%	2.7	0.85	0.82	1.4	
NPI52W681MTRF	680 ± 20%	2.2	1.10	0.72	1.2	
NPI52W102MTRF	1000 ± 20%	2.0	1.80	0.56	1.0	
NPI52W472MTRF	4700 ± 20%	-	7.50	0.25	0.35	

Maximum +40°C temperature rise at Irms. Typical -10% inductance change at Isat.

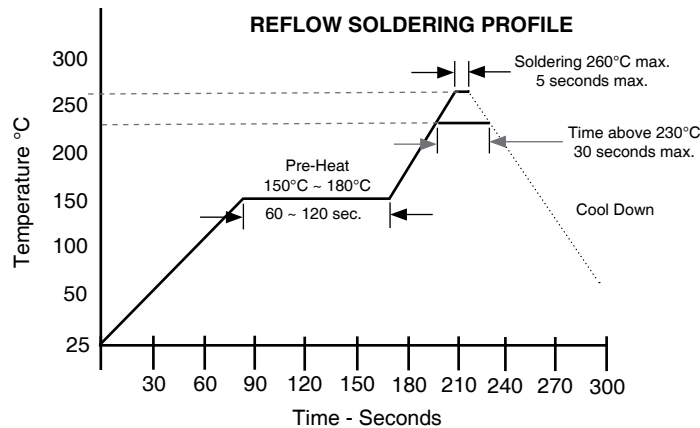

Case Size	TAPING DIMENSIONS (mm)					
	Ao	Bo	Co	Ko	W	Po
NPI16W	4.60	6.70	4.25	3.20	12.0	8.0
NPI31W	10.00	13.50	11.50	5.60	24.0	12.0
NPI34W	10.00	13.50	11.50	11.6	24.0	20.0
NPI52W	15.40	18.70	14.25	7.60	32.0	20.0

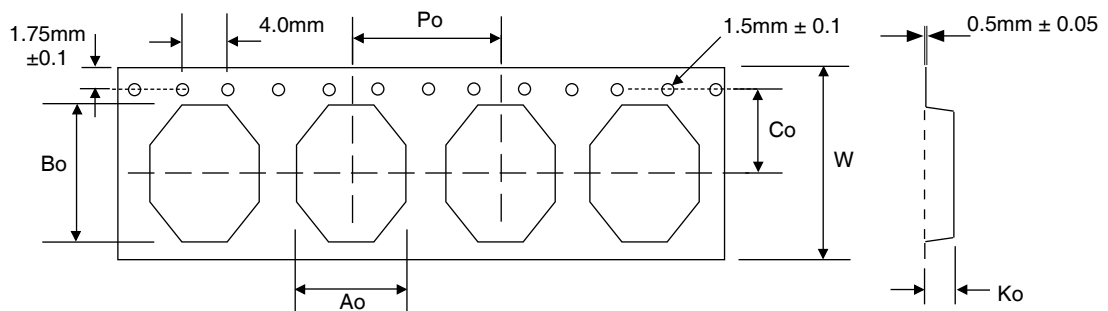

Size	REEL QUANTITY PER CASE SIZE				
	NPI16W	NPI22W	NPI31W	NPI34W	NPI52W
Quantity per reel	2500	1000	500	225	250
Tape Width	16mm	24mm	24mm	32mm	32mm

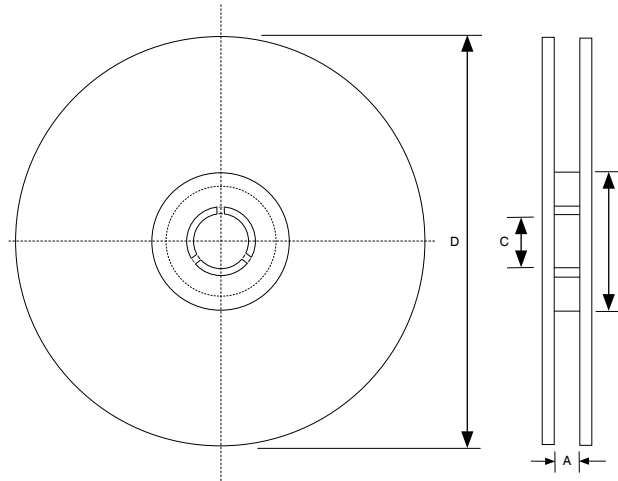

Tape Width	REEL DIMENSIONS (mm)			
	A(mm)	B(mm)	C(mm)	D(mm)
16mm	16.5±0.1	100±1	13±0.5	330
24mm	24.5±0.1			
32mm	32.5±0.1			

## X-ON Electronics

Largest Supplier of Electrical and Electronic Components

*Click to view similar products for [nic manufacturer](#):*

Other Similar products are found below :

[NMC0603NPO0R6B50TRPF](#) [NMC0603NPO270J100TRPF](#) [NMC1206X5R226K6.3TRPLP2KF](#) [NRE-S100M25V4X7F](#) [NRE-  
HS102M25V12.5X16F](#) [NRCA12F1001TRQYF](#) [NRC-S06F2212TRF](#) [NCD180J1KVNPOJTRF](#) [NRC-S06F1692TRF](#)  
[NCD102M1KVZ5U.250STRF](#) [NTC-T105K20TRAF](#) [NMC-P1206X7R104K100TRPF](#) [NMC-H1206NPO471K1KVTRPLPF](#) [NML04J9N1TRF](#)  
[NRSNA4I4J150TR40KF](#) [NCC0805F261HTRF](#) [NRWA470M35V6.3X11TBF](#) [NACE221M16V6.3X8TR13F](#) [NRSS332M50V18X35.5F](#)  
[NDTM106K25F1TRF](#) [NACZ221M50V10X10.5TR13F](#) [NCM15X7R103K50F](#) [NCD103M1KVZ5UF](#) [NRSS682M25V18X35.5F](#)  
[NEXC224Z5.5V10.5X8.5TRF](#) [NRLRW221M450V30X35SF](#) [NDTM225K50F2TRF](#) [NRSZ471M50V12.5X20F](#) [NTCL106K35TRDF](#)  
[NRWA331M25V10X12.5F](#) [NRSY472M25V16X31.5F](#) [NEXS105Z5.5V28.5X14F](#) [NRLR181M400V25X30SF](#) [NRSZ102M25V12.5X20F](#)  
[NUVA33T385TRF](#) [NUVA33V405TRF](#) [NRLMW331M250V30X25F](#) [NRLF103M25V35X20F](#) [NDTM106K35F](#) [NRLMW102M200V35X35F](#)  
[NPIS43LS220MTRF](#) [NDTM476K35F2F](#) [NTC-T475K50TRDF](#) [NCD222M1KVZ5UKF](#) [NRLR472M63V25X40SF](#) [NTP157M10TRD\(40\)F](#)  
[NPIM74C3R3MTRF](#) [NPI104C100MTRF](#) [NRLM102M100V25X25F](#) [NRLM223M50V 35X50F](#)