

General-purpose CMOS Logic IC Series (BU4S,BU4000B Series)

High Voltage CMOS Logic ICs <Function Logic>



**BU4015B,BU4015BF,BU4021B,BU4021BF,
BU4094BC,BU4094BCF,BU4094BCFV,BU4538B,BU4028B**

No.09050EAT04

●Description

BU4015B series ICs are 4-stage static shift registers, each consisting of 2 circuits. The D flip-flops of each stage share a common reset input, enabling asynchronous reset at any time.

BU4021B series ICs are 8-bit static shift registers configured with 8 register cells, each of which has parallel input. Control of the parallel/serial input (P/S) enables serial input/output with clock synchronization and well as parallel input/serial output conversions.

BU4094BC series ICs are shift/store registers, each consisting of an 8-bit shift register and an 8-bit latch. Output can be held in the data transfer mode because the data read into the shift register can be latched by the asynchronous strobe input, The BU4538B IC is a monostable multivibrator that can be reset and retrigged from either edge of an input pulse. A wide range of accurate output pulse widths is available because the output pulse width and accuracy are determined by the external timing constants Cx an Rx.

The BU4028B IC is a decoder which converts BCD signals into decimal signals.
Of the 10 outputs (Q0 ~ Q9), those corresponding to the input codes A-D are set to "H", while the others are set to "L".

●Features

- 1) Low power consumption
- 2) Wide operating supply voltage range
- 3) High impedance
- 4) High fan out
- 5) L-TTL2 and LS-TTL1 inputs can be driven directly.

●Applications

BU4015B: serial / parallel data conversion and ring counter.

BU4021B: control circuits, timing circuits and as a general purpose register requiring high degree of noise tolerance.

BU4094BC: series/parallel data conversion and data receivers.

BU4538B: can obtain the output pulse amplitude with improved accuracy by external capacity and resistance.

BU4028B: code conversion, address decoding, memory selection control, demultiplexing or readout and decoding, etc.

●Lineup

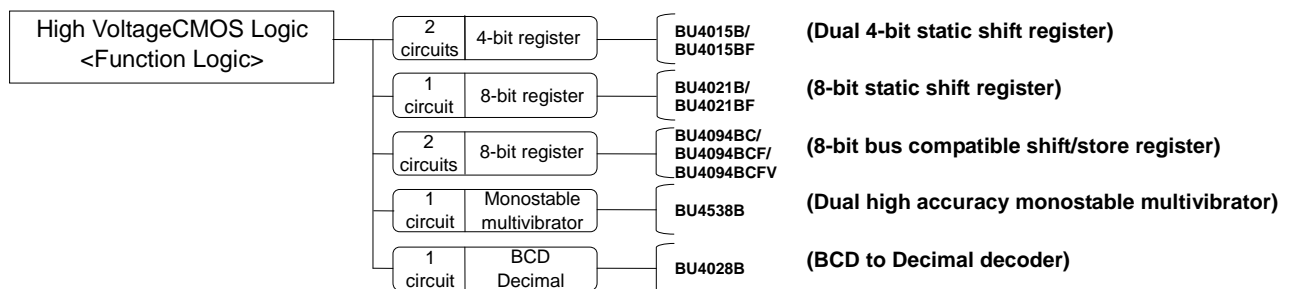

● Absolute Maximum Ratings

Parameter	Symbol	Limit					Unit
		BU4015B	BU4021B	BU4094BC	BU4538B	BU4028B	
Power Supply Voltage	VDD	-0.3 to 18					V
Supply Current	Iin	±10					mA
Operating Temperature	Topr	-40 to 85					°C
Storage Temperature	Tstg	-55 to 150					°C
Input Voltage	VIN	-0.3 to VDD+0.3					V
Maximum Junction Temperature	Tjmax	150					°C

● Recommended Operating Conditions

Parameter	Symbol	Limit					Unit
		BU4015B	BU4021B	BU4094BC	BU4538B	BU4028B	
Operating Power Supply	VDD	3 to 16 (3 to 18V @BU4094BC)					V
Input Voltage	VIN	0 to VDD					V

● Thermal Derating Curve

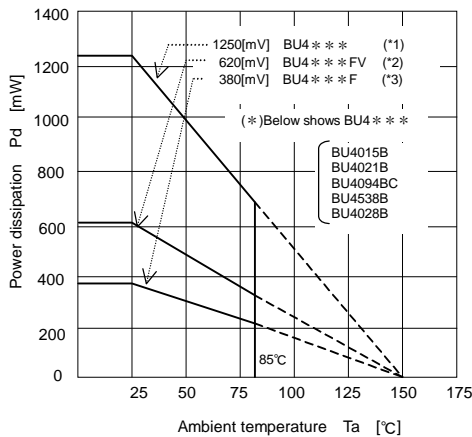

(*1)	(*2)	(*3)	Unit
10.0	5.0	3.1	mW/°C

When used at Ta=25°C or higher the value above is reduced per 1°C. Power Dissipation is measured by using the sample mounted on a 70mmx70mmx1.6mm FR4 glass-epoxy PCB (copper area is less than 3%)

● Input / Output Equivalent Circuits

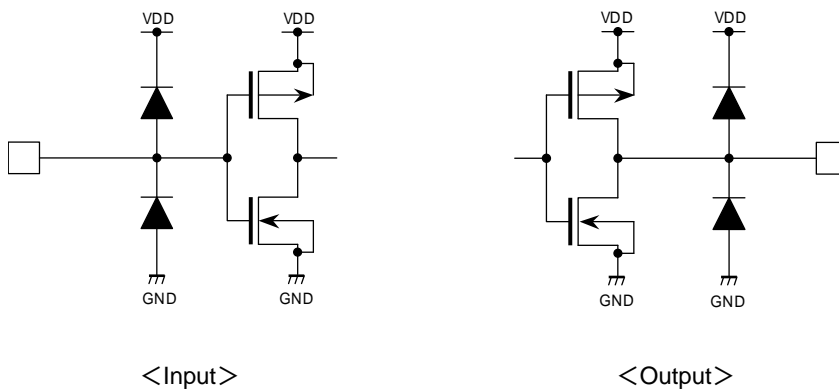

● Electrical Characteristics (BU4015B)

DC Characteristics (Unless otherwise noted VSS=0[V], Ta=25[°C])

Parameter	Symbol	Limits			Unit	VDD[V]	Condition	Fig.No
		Min	Typ	Max				
Input 'H' voltage	VIH	3.5	—	—	V	5	—	—
		7.0	—	—		10		
		11.0	—	—		15		
Input 'L' voltage	VIL	—	—	1.5	V	5	—	—
		—	—	3.0		10		
		—	—	4.0		15		
Input 'H' current	I _{IH}	—	—	0.3	μA	15	VIH=15[V]	—
Input 'L' current	I _{IL}	—	—	-0.3	μA	15	VIL=0[V]	—
Output 'H' voltage	VOH	4.95	—	—	V	5	IO=0[mA]	1
		9.95	—	—		10		
		14.95	—	—		15		
Output 'L' voltage	VOL	—	—	0.05	V	5	IO=0[mA]	2
		—	—	0.05		10		
		—	—	0.05		15		
Output 'H' current	IOH	-0.16	—	—	mA	5	VOH=4.6[V]	1
		-0.4	—	—		5	VOH=9.5[V]	
		-1.2	—	—		15	VOH=13.5[V]	
Output 'L' current	IOL	0.44	—	—	mA	5	VOL=0.4[V]	2
		1.1	—	—		10	VOL=0.5[V]	
		3.0	—	—		15	VOL=1.5[V]	
Static supply current	IDD	—	—	20	μA	5	VI=VSS or GND	—
		—	—	40		10		
		—	—	80		15		

Switching Characteristics (Unless otherwise noted VSS=0[V], Ta=25[°C], CL=50[pF])

Parameter	Symbol	Limits			Unit	VDD[V]	Condition	Fig.No
		Min	Typ	Max				
Output rising time	t _{TLH}	—	180	—	ns	5	—	—
		—	90	—		10		
		—	65	—		15		
Output falling time	T _T HL	—	100	—	ns	5	—	—
		—	50	—		10		
		—	40	—		15		
Propagation delay time CLOCK, D→Q	t _{PLH} t _{PHL}	—	310	—	ns	5	—	3 · 4
		—	125	—		10		
		—	90	—		15		
Propagation delay time RESET→Q	t _{PLH} t _{PHL}	—	460	—	ns	5	—	5 · 6
		—	180	—		10		
		—	120	—		15		
Set up time	T _{su}	—	100	—	ns	5	—	7 · 8
		—	50	—		10		
		—	40	—		15		
Minimum clock pulse width	t _W (CLK)	—	185	—	ns	5	—	9
		—	85	—		10		
		—	55	—		15		
Minimum reset pulse width	t _W (RST)	—	200	—	ns	5	—	10
		—	80	—		10		
		—	60	—		15		
Maximum clock frequency	f (CLK) Max.	—	20	—	MHz	5	—	—
		—	6.0	—		10		
		—	7.5	—		15		
Maximum clock rising/falling time	tr(CLK) tf(CLK)	—	100	—	μs	5	—	—
		—	40	—		10		
		—	15	—		15		
Input capacitance	C _{IN}	—	5	—	pF	—	—	—

● Electrical Characteristics (BU4021B)

DC Characteristics (Unless otherwise noted VSS=0[V], Ta=25[°C])

Parameter	Symbol	Limits			Unit	VDD[V]	Condition	Fig.No
		Min	Typ	Max				
Input 'H' voltage	VIH	3.5	—	—	V	5	—	—
		7.0	—	—		10		
		11.0	—	—		15		
Input 'L' voltage	VIL	—	—	1.5	V	5	—	—
		—	—	3.0		10		
		—	—	4.0		15		
Input 'H' current	I _{IH}	—	—	0.3	μA	15	VIH=15[V]	—
Input 'L' current	I _{IL}	—	—	-0.3	μA	15	VIL=0[V]	—
Output 'H' voltage	VOH	4.95	—	—	V	5	IO=0[mA]	11
		9.95	—	—		10		
		14.95	—	—		15		
Output 'L' voltage	VOL	—	—	0.05	V	5	IO=0[mA]	12
		—	—	0.05		10		
		—	—	0.05		15		
Output 'H' current	IOH	-0.16	—	—	mA	5	VOH=4.6[V]	11
		-0.4	—	—		5	VOH=9.5[V]	
		-1.2	—	—		15	VOH=13.5[V]	
Output 'L' current	IOL	0.44	—	—	mA	5	VOL=0.4[V]	12
		1.1	—	—		10	VOL=0.5[V]	
		3.0	—	—		15	VOL=1.5[V]	
Static supply current	IDD	—	—	20	μA	5	VI=VDD or GND	—
		—	—	40		10		
		—	—	80		15		

Switching Characteristics (Unless otherwise noted VSS=0[V], Ta=25[°C], CL=50[pF])

Parameter	Symbol	Limits			Unit	VDD[V]	Condition	Fig.No
		Min	Typ	Max				
Output rising time	t _{TLH}	—	180	—	ns	5	—	—
		—	90	—		10		
		—	65	—		15		
Output falling time	t _{THL}	—	100	—	ns	5	—	—
		—	50	—		10		
		—	40	—		15		
“L” to “H” Propagation delay time CLOCK→Q P/S→Q	t _{PLH}	—	400	—	ns	5	—	13 · 15
		—	170	—		10		
		—	115	—		15		
“H” to “L” Propagation delay time CLOCK→Q P/S→Q	t _{PHL}	—	400	—	ns	5	—	14 · 16
		—	170	—		10		
		—	115	—		15		
Set up time	t _{su}	—	150	—	ns	5	—	17
		—	50	—		10		
		—	30	—		15		
Minimum clock pulse width	t _w (CLK)	—	150	—	ns	5	—	19
		—	75	—		10		
		—	40	—		15		
Maximum clock frequency	f (CLK) Max.	—	3.0	—	MHz	5	—	—
		—	6.0	—		10		
		—	8.0	—		15		
Maximum clock rising/falling time	t _r (CLK) t _f (CLK)	—	—	15	μs	5	—	—
		—	—	5.0		10		
		—	—	4.0		15		
Minimum P/S Control pulse width	t _w (P/S)	—	150	—	ns	5	—	20
		—	75	—		10		
		—	40	—		15		
Input capacitance	C _{IN}	—	5	—	pF	—	—	—

● Electrical Characteristics (BU4094BC)

DC Characteristics (Unless otherwise noted VSS=0[V], Ta=25[°C])

Parameter	Symbol	Limits			Unit	VDD[V]	Condition	Fig.No
		Min	Typ	Max				
Input 'H' voltage	VIH	3.5	—	—	V	5	—	—
		7.0	—	—		10		
		11.0	—	—		15		
Input 'L' voltage	VIL	—	—	1.5	V	5	—	—
		—	—	3.0		10		
		—	—	4.0		15		
Input 'H' current	I _{IH}	—	—	0.3	μA	15	VIH=15[V]	—
Input 'L' current	I _{IL}	—	—	-0.3	μA	15	VIL=0[V]	—
Output 'H' voltage	VOH	4.95	—	—	V	5	IO=0[mA]	21
		9.95	—	—		10		
		14.95	—	—		15		
Output 'L' voltage	VOL	—	—	0.05	V	5	IO=0[mA]	22
		—	—	0.05		10		
		—	—	0.05		15		
Output 'H' current	IOH	-0.44	—	—	mA	5	VOH=4.6[V]	21
		-1.1	—	—		5	VOH=9.5[V]	
		-3.0	—	—		15	VOH=13.5[V]	
Output 'L' current	IOL	0.44	—	—	mA	5	VOL=0.4[V]	22
		1.1	—	—		10	VOL=0.5[V]	
		3.0	—	—		15	VOL=1.5[V]	
Static supply current	IDD	—	—	5	μA	5	VI=VDD or GND	—
		—	—	10		10		
		—	—	20		15		

Switching Characteristics (Unless otherwise noted VSS=0[V], Ta=25[°C], CL=50[pF])

Parameter	Symbol	Limits			Unit	VDD[V]	Condition	Fig.No
		Min	Typ	Max				
Output rising time	t _{TLH}	—	100	200	ns	5	—	—
		—	50	100		10		
		—	40	80		15		
Output falling time	t _{THL}	—	100	200	ns	5	—	—
		—	50	100		10		
		—	40	80		15		
Propagation delay time CLOCK→QS	t _{PLH} t _{PHL}	—	350	600	ns	5	—	23
		—	125	250		10		
		—	95	190		15		
Propagation delay time CLOCK→Q'S	t _{PLH} t _{PHL}	—	230	460	ns	5	—	24
		—	110	220		10		
		—	75	150		15		
Propagation delay time CLOCK→QN	t _{PLH} t _{PHL}	—	420	840	ns	5	—	25
		—	195	390		10		
		—	135	270		15		
Propagation delay time STROBE→QN	t _{PLH} t _{PHL}	—	290	580	ns	5	—	26
		—	145	290		10		
		—	100	200		15		
3state Propagation delay time Output Enable→QN	t _{PHZ} t _{PZH}	—	140	280	ns	5	RL=1[kΩ]	27
		—	75	150		10		
		—	55	110		15		
3 state Propagation delay time Output Enable→QN	t _{PLZ} t _{PZL}	—	140	280	ns	5	RL=1[kΩ]	28
		—	75	150		10		
		—	55	110		15		
Minimum set up time DATA→CLOCK	tsu	—	20	125	ns	5	—	29
		—	8	55		10		
		—	6	35		15		
Minimum hold time CLOCK →DATA	tH	—	10	40	ns	5	—	30
		—	10	20		10		
		—	5	15		15		
Minimum clock pulse width	tW(CLK)	—	100	200	ns	5	—	31
		—	50	100		10		
		—	40	80		15		
Maximum clock rising/falling time	tr(CL) tf(CL)	NO Limit			μs	5	—	—
						10		
						15		
Maximum clock frequency	f _{CL}	1.25	2.5	—	MHz	—	—	—
		2.5	5	—		—		
		3.0	12.5	—		—		
Minimum strobe pulse width	T _{wH}	—	100	200	ns	—	—	—
		—	40	80		—		
		—	35	70		—		
Input capacitance	C _{IN}	—	5	—	pF	—	—	—

● Electrical Characteristics (BU4538B)

DC Characteristics (Unless otherwise noted VSS=0[V], Ta=25[°C])

Parameter	Symbol	Limits			Unit	VDD[V]	Condition	Fig.No
		Min	Typ	Max				
Input 'H' voltage	VIH	3.5	—	—	V	5	—	—
		7.0	—	—		10		
		11.0	—	—		15		
Input 'L' voltage	VIL	—	—	1.5	V	5	—	—
		—	—	3.0		10		
		—	—	4.0		15		
Input 'H' current	I _{IH}	—	—	0.3	μA	15	VIH=15[V]	—
Input 'L' current	I _{IL}	—	—	-0.3	μA	15	VIL=0[V]	—
Output 'H' voltage	VOH	4.95	—	—	V	5	IO=0[mA]	—
		9.95	—	—		10		
		14.95	—	—		15		
Output 'L' voltage	VOL	—	—	0.05	V	5	IO=0[mA]	—
		—	—	0.05		10		
		—	—	0.05		15		
Output 'H' current	IOH	-0.16	—	—	mA	5	VOH=4.6[V]	—
		-0.4	—	—		5	VOH=9.5[V]	
		-1.2	—	—		15	VOH=13.5[V]	
Output 'L' current	IOL	0.44	—	—	mA	5	VOL=0.4[V]	—
		1.1	—	—		10	VOL=0.5[V]	
		3.0	—	—		15	VOL=1.5[V]	
Static supply current	IDD	—	—	20	μA	5	VI=VDD or GND	—
		—	—	40		10		
		—	—	80		15		

Switching Characteristics (Unless otherwise noted VSS=0[V], Ta=25[°C], CL=50[pF])

Parameter	Symbol	Limits			Unit	VDD[V]	Condition	Fig.No
		Min	Typ	Max				
Output rising time	t _{TLH}	—	100	—	ns	5	—	—
		—	50	—		10		
		—	40	—		15		
Output falling time	t _{THL}	—	100	—	ns	5	—	—
		—	50	—		10		
		—	40	—		15		
Propagation delay time A, B → Q, Q̄	t _{PLH} t _{PHL}	—	300	—	ns	5	—	32 · 33
		—	150	—		10		
		—	100	—		15		
Propagation delay time CD → Q, Q̄	t _{PLH} t _{PHL}	—	250	—	ns	5	—	34 · 35
		—	125	—		10		
		—	95	—		15		
Minimum input pulse width	t _{WIN}	—	50	—	ns	5	—	36
		—	30	—		10		
		—	25	—		15		
Output pulse width 1	t _{WOUT1}	185	200	215	μs	5	CX=2000[pF] RX=100[kΩ]	38
		185	200	215		10		
		185	200	215		15		
Output pulse width 2	t _{WOUT2}	8.8	9.4	10.0	ms	5	CX=0.1[μF] RX=100[kΩ]	39
		8.8	9.4	10.0		10		
		8.8	9.4	10.0		15		
Minimum trigger time	t _{rr}	—	0	—	ns	5	—	—
		—	0	—		10		
		—	0	—		15		
Input capacitance	C _{IN}	—	5	—	pF	—	—	—

● Electrical Characteristics (BU4028B)

DC Characteristics (Unless otherwise noted VSS=0[V], Ta=25[°C])

Parameter	Symbol	Limits			Unit	VDD[V]	Condition	Fig.No
		Min	Typ	Max				
Input 'H' voltage	VIH	3.5	—	—	V	5	—	—
		7.0	—	—		10		
		11.0	—	—		15		
Input 'L' voltage	VIL	—	—	1.5	V	5	—	—
		—	—	3.0		10		
		—	—	4.0		15		
Input 'H' current	I _{IH}	—	—	0.3	μA	15	VIH=15[V]	—
Input 'L' current	I _{IL}	—	—	-0.3	μA	15	VIL=0[V]	—
Output 'H' voltage	VOH	4.95	—	—	V	5	IO=0[mA]	40
		9.95	—	—		10		
		14.95	—	—		15		
Output 'L' voltage	VOL	—	—	0.05	V	5	IO=0[mA]	41
		—	—	0.05		10		
		—	—	0.05		15		
Output 'H' current	IOH	-0.16	—	—	mA	5	VOH=4.6[V]	40
		-0.4	—	—		5	VOH=9.5[V]	
		-1.2	—	—		15	VOH=13.5[V]	
Output 'L' current	IOL	0.44	—	—	mA	5	VOL=0.4[V]	41
		1.1	—	—		10	VOL=0.5[V]	
		3.0	—	—		15	VOL=1.5[V]	
Static supply current	IDD	—	—	1	μA	5	VI=VDD or GND	—
		—	—	2		10		
		—	—	4		15		

Switching Characteristics (Unless otherwise noted VSS=0[V], Ta=25[°C], CL=50[pF])

Parameter	Symbol	Limits			Unit	VDD[V]	Condition	Fig.No
		Min	Typ	Max				
Output rising time	t _{TLH}	—	180	—	ns	5	—	42
		—	90	—		10		
		—	65	—		15		
Output falling time	t _{THL}	—	100	—	ns	5	—	43
		—	50	—		10		
		—	40	—		15		
“L” to “H” Propagation delay time	t _{PLH}	—	300	—	ns	5	—	44
		—	130	—		10		
		—	90	—		15		
“H” to “L” Propagation delay time	t _{PHL}	—	300	—	ns	5	—	45
		—	130	—		10		
		—	90	—		15		
Input capacitance	C _{IN}	—	5	—	pF	—	—	—

● Electrical Characteristics Curves (BU4015B)

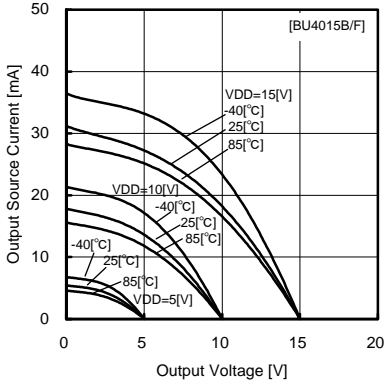

Fig.1 Output source current - voltage

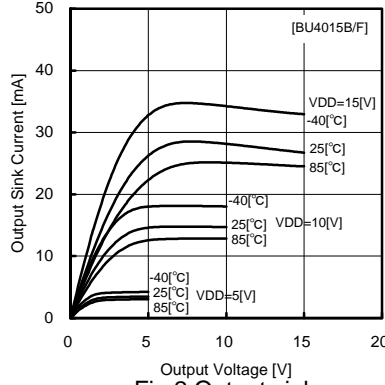

Fig.2 Output sink current - voltage

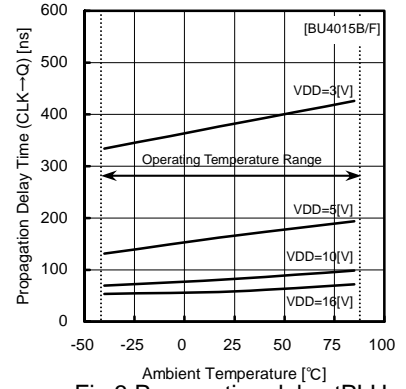

Fig.3 Propagation delay tPLH CLK→Q

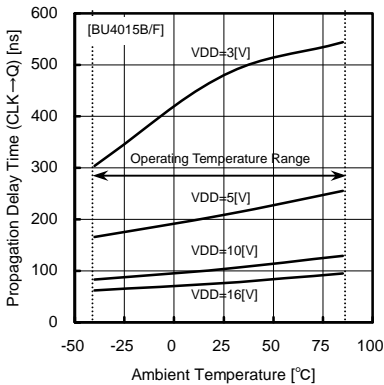

Fig.4 Propagation delay tPHL CLK→Q

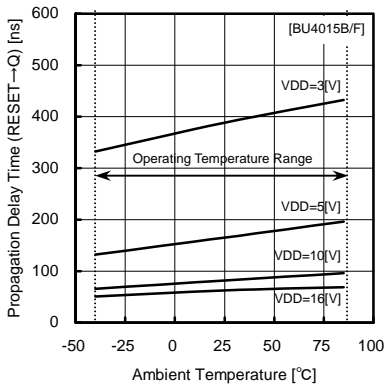

Fig.5 Propagation delay tPLH RESET→Q

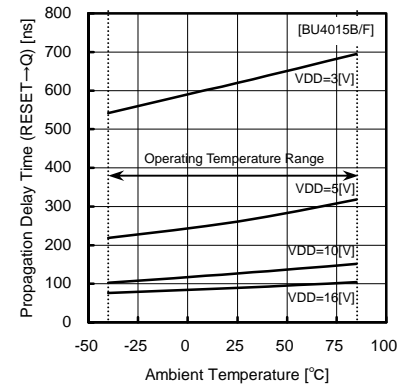

Fig.6 Propagation delay tPHL RESET→Q

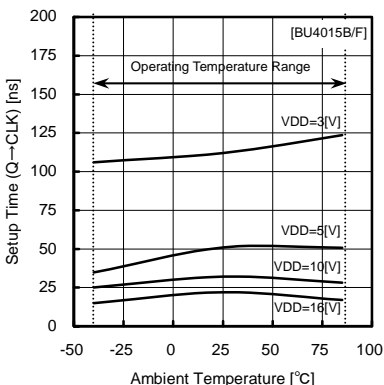

Fig.7 Set up time tsu Q→CLK

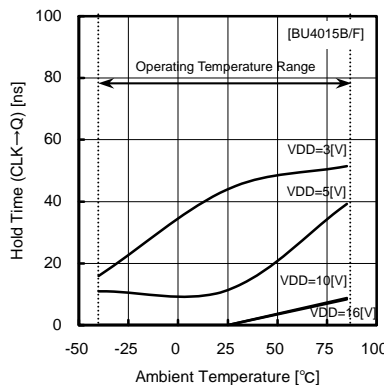

Fig.8 Hold time th CLK→Q

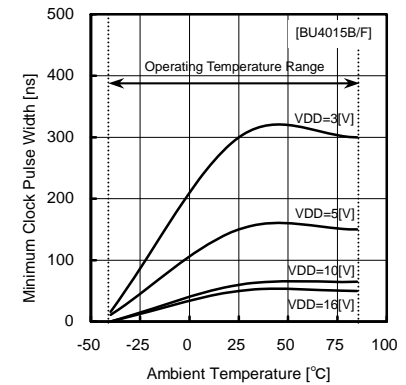

Fig.9 Minimum CLK pulse width

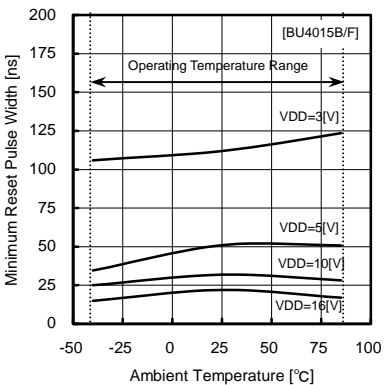
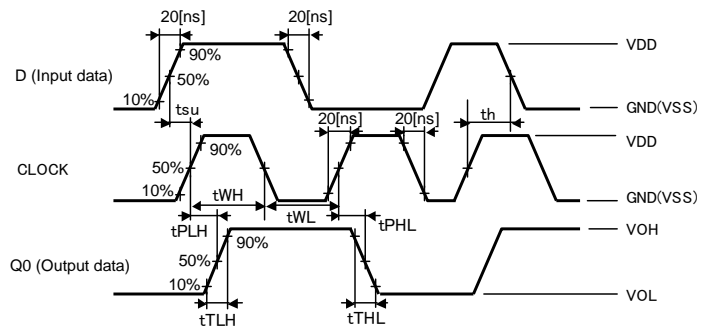

Fig.10 Minimum RESET pulse width

○ Switching characteristics



● Electrical Characteristics Curves (BU4021B)

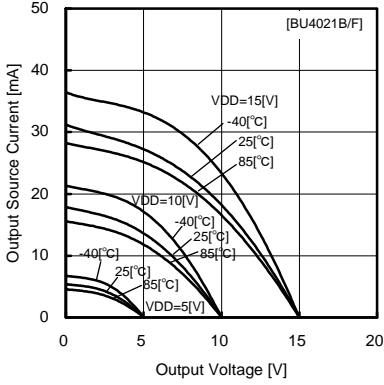

Fig. 11 Output source current - voltage

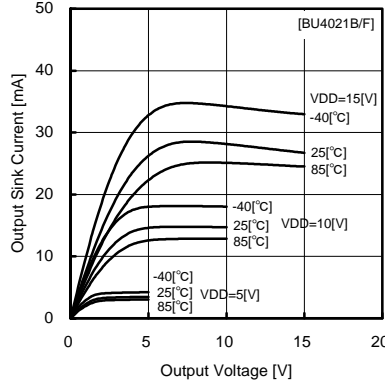

Fig. 12 Output sink current - voltage

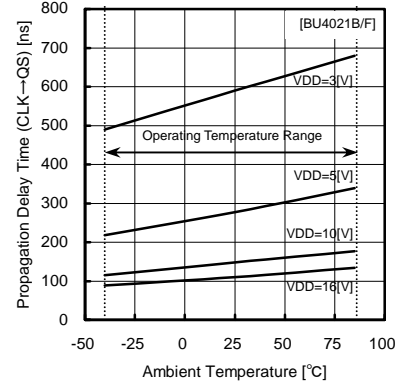

Fig. 13 Propagation delay tPLH CLK → QS

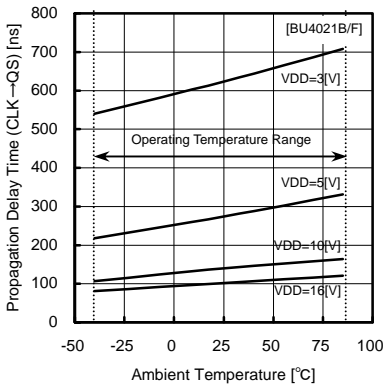

Fig. 14 Propagation delay tPHL CLK → QS

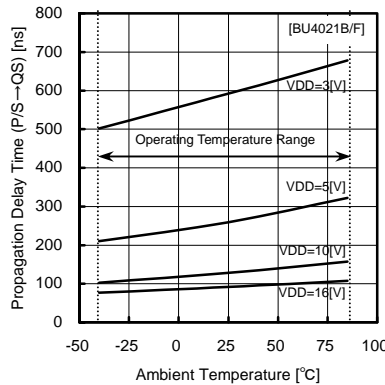

Fig. 15 Propagation delay tPLH P/S → QS

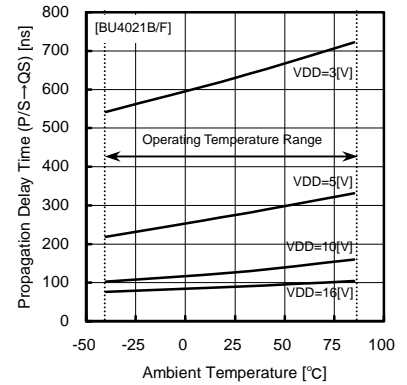

Fig. 16 Propagation delay tPHL P/S → QS

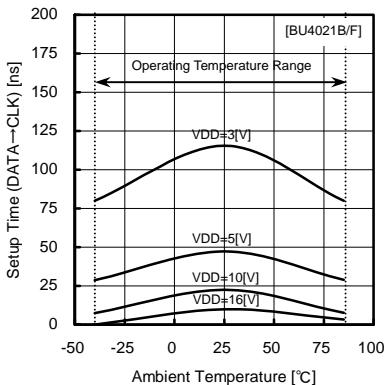

Fig. 17 Set up time tsu Q → CLK

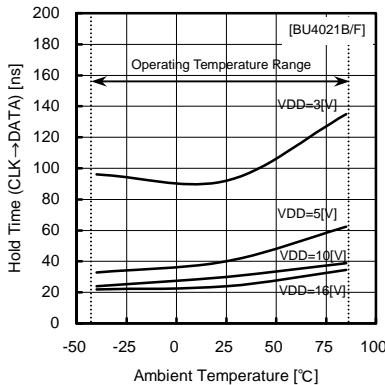

Fig. 18 Hold time th CLK → Q

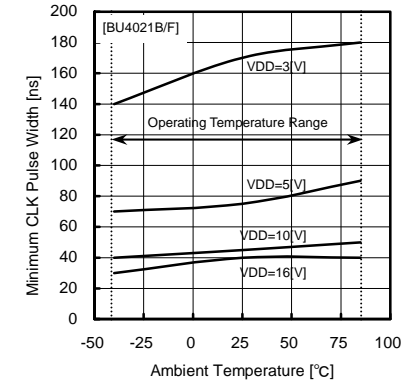

Fig. 19 Minimum CLK pulse width

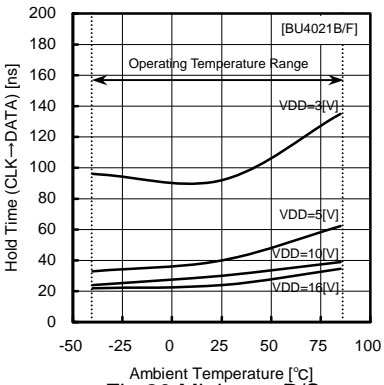
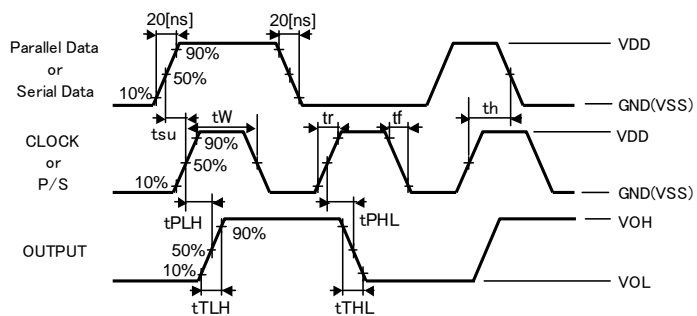

Fig. 20 Minimum P/S pulse width

○ Switching characteristics



● Electrical Characteristics Curves (BU4094BC)

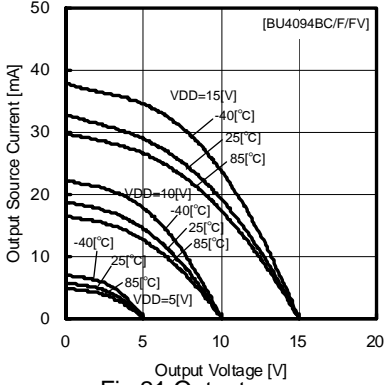

Fig.21 Output source current - voltage

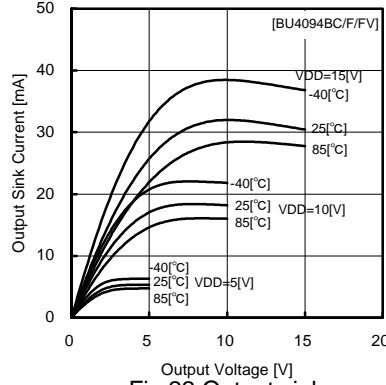

Fig.22 Output sink current - voltage

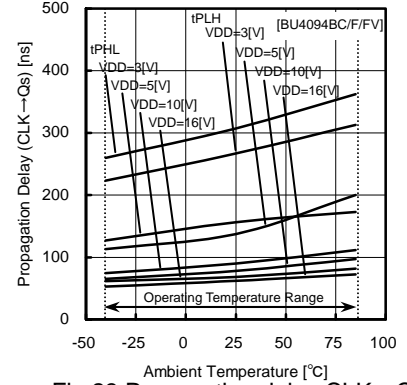

Fig.23 Propagation delay CLK -> QS

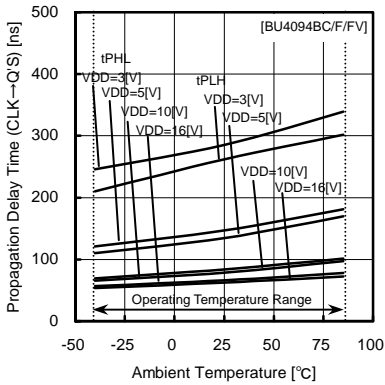

Fig.24 Propagation delay CLK -> Q'S

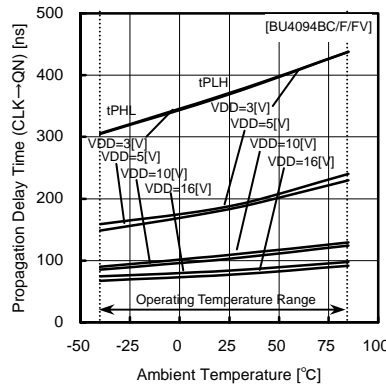

Fig.25 Propagation delay CLK -> QN

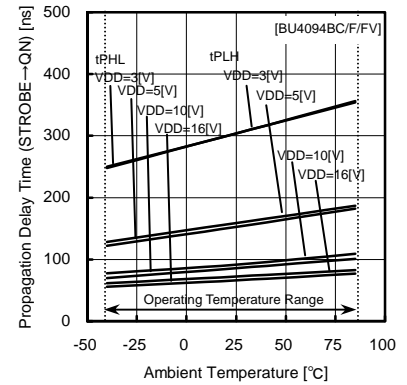

Fig.26 Propagation delay STROBE -> QN

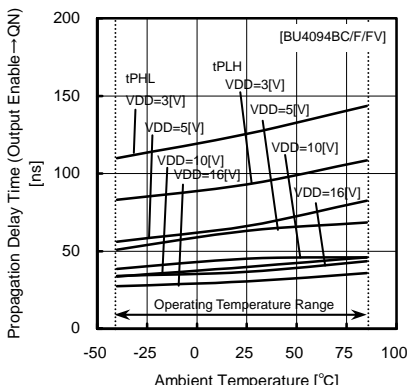

Fig.27 Propagation delay tPHZ Output Enable -> QN

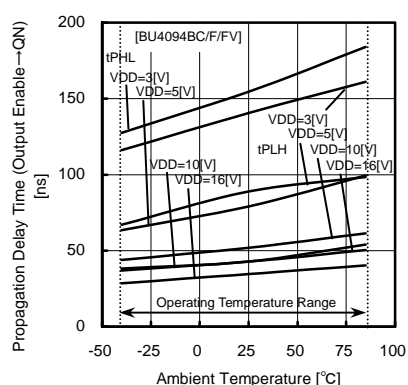

Fig.28 Propagation delay tPLZ Output Enable -> QN

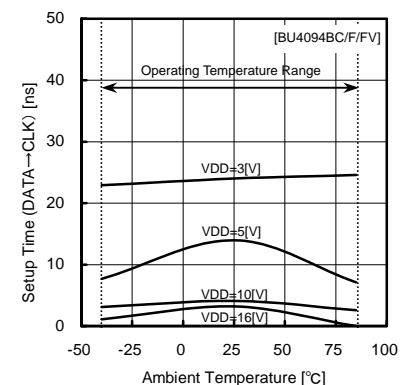

Fig.29 Set up time tsu DATA -> CLK

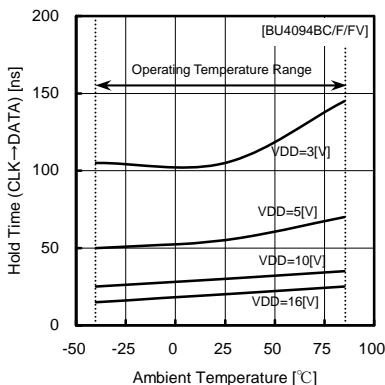

Fig.30 Hold time tH CLK -> DATA

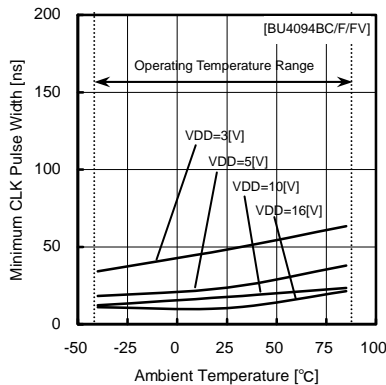

Fig.31 Minimum CLK pulse width tW(CLK)

○ Switching characteristics are stated on page 14.

● Electrical Characteristics Curves (BU4538B)

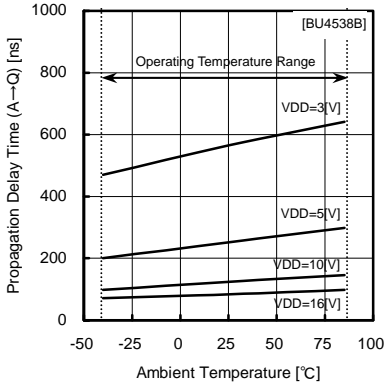

Fig.32 Propagation delay tPLH A→Q

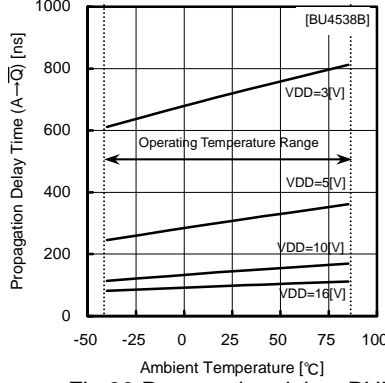

Fig.33 Propagation delay tPHL A→Q

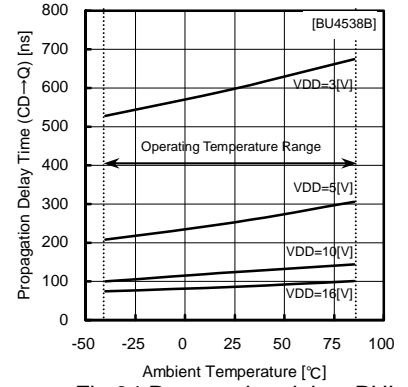

Fig.34 Propagation delay tPHL CD→Q

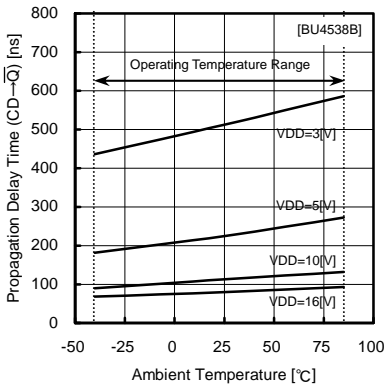

Fig.35 Propagation delay tPLH CD→Q

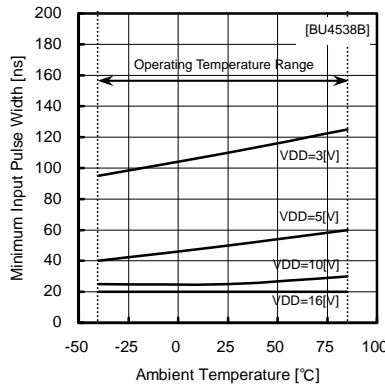

Fig.36 Minimum input pulse width tWIN

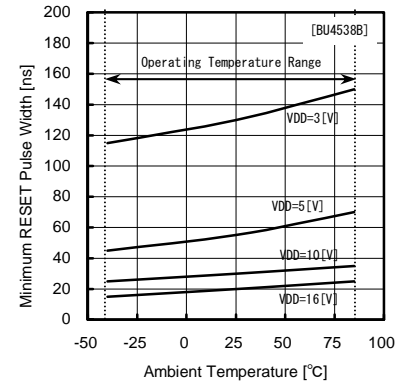

Fig.37 Minimum RESET pulse width tRESET

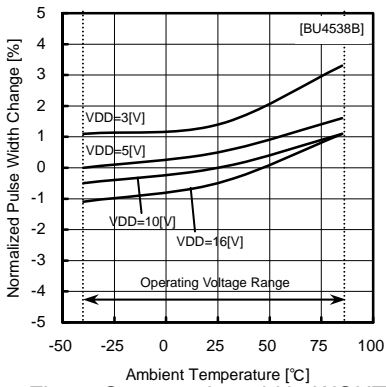

Fig.38 Output pulse width tWOUT1 (CX=2000[pF], RX=100[kΩ])

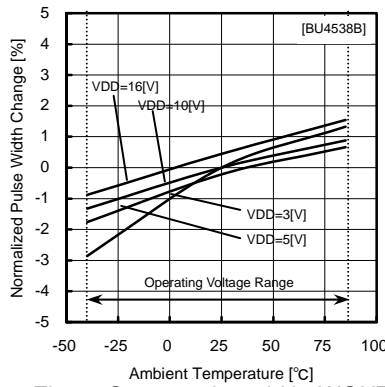
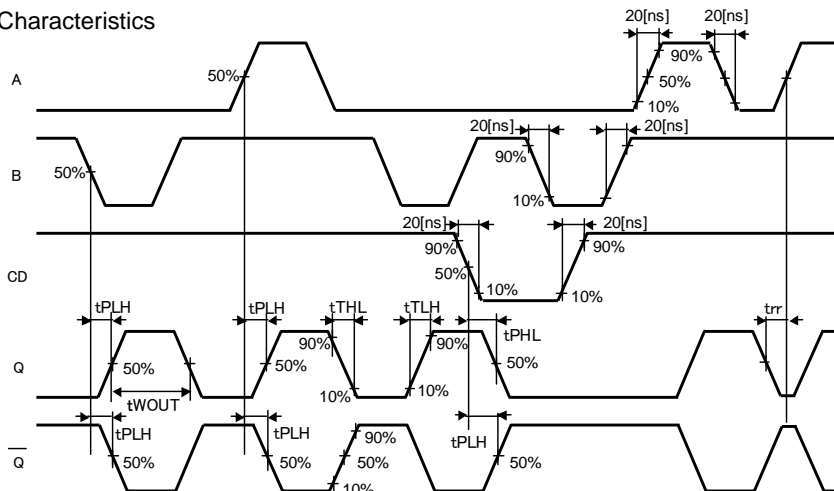

Fig.39 Output pulse width tWOUT2 (CX=0.1[μF], RX=100[kΩ])

○ Switching Characteristics



●Reference data(BU4028B)

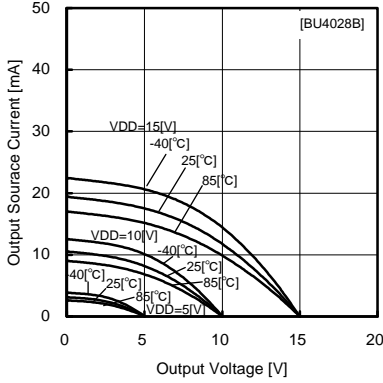

Fig.40 Output source current - voltage

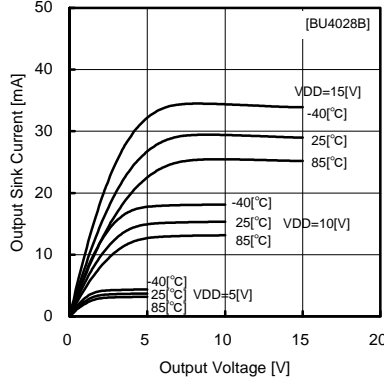

Fig.41 Output sink current - voltage

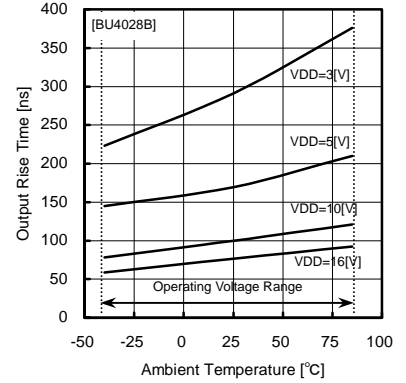

Fig.42 Propagation delay tTLH

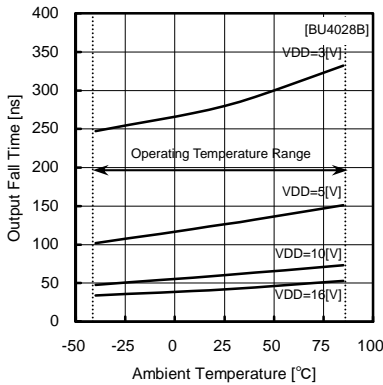

Fig.43 Propagation delay tTHL

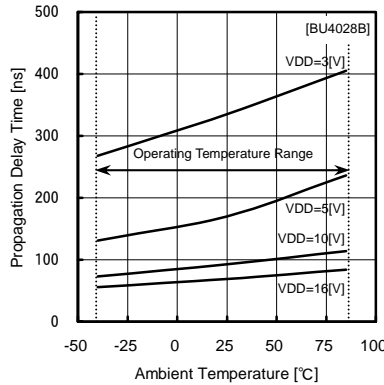

Fig.44 Propagation delay tPLH

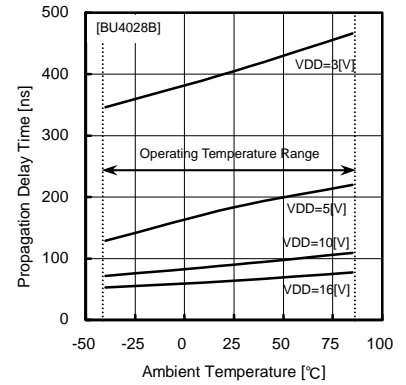

Fig.45 Propagation delay tPHL

(*) Switching characteristics is shown in P15.

●Description of BU4015B series model

Function : Dual 4-bit static shift register

1) Description of operation

Dual 4-bit static shift register of BU4015B is configured with 2 independent serial input/parallel output registers of the same 4-state. Each register is provided with an independent clock and reset input having one series data input. Register state is the D type master/slave flip-flop. Data is shifted to the next stage during the rise time of the clock. Each register can be cleared by addition of "H" level to reset.

PIN arrangement

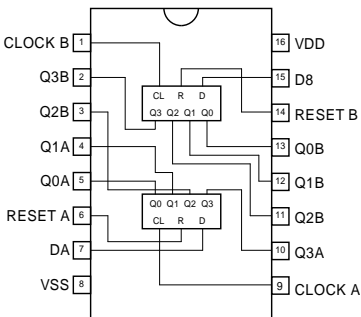

Block diagram

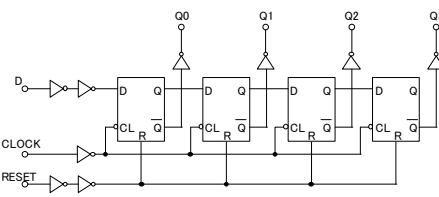

PIN description

PIN No.	Symbol	I/O	Function
1	CLOCKB	I	Clock input (CHB)
2	Q3B	O	Output 3 (CHB)
3	Q2A	O	Output 2 (CHA)
4	Q1A	O	Output 1 (CHB)
5	Q0A	O	Output 0 (CHA)
6	RESETA	I	Reset input (CHA)
7	DA	I	Data input (CHA)
8	VSS	—	Power supply(-)
9	CLOCKA	I	Clock input (CHA)
10	Q3A	O	Output 3 (CHA)
11	Q2B	O	Output 2 (CHB)
12	Q1B	O	Output 1 (CHB)
13	Q0B	O	Output 0 (CHB)
14	RESETB	I	Reset input (CHB)
15	DB	I	Data input (CHB)
16	VDD	—	Power supply(+)

Truth table

CLOCK	D	RESET	Q0	Q1	Q2	Q3
↑	L	L	L	Q0	Q1	Q2
↑	H	L	H	Q0	Q1	Q2
↓	X	L	L	No Change		
X	X	H	L	L	L	L

X: Don't Care

●Description of BU4021B series model

Function: 8-stage static shift register

1)Description of operation

BU4021B is an 8-bit static shift register capable of parallel input/series output and series input/series output. In parallel operation, DS (data) being asynchronous with the clock is inputted into each F/F and obtained at output.

In series operation, DS (data) is triggered by clock.

When P/S input level is "H", parallel operation is effective, and when P/S input level is "L", series operation is effective.

PIN arrangement

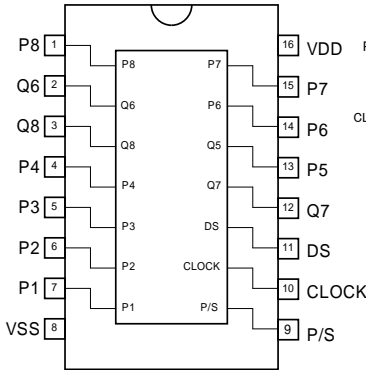

Block diagram

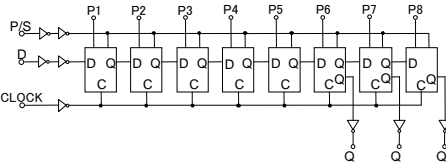

PIN description

PIN No.	Symbol	I/O	Function
1	P8	I	Parallel data input 8
2	Q6	O	Output 6
3	Q8	O	Output 8
4	P4	I	Parallel data input 4
5	P3	I	Parallel data input 3
6	P2	I	Parallel data input 2
7	P1	I	Parallel data input 1
8	VSS	—	Power supply(-)
9	P/S	I	Parallel/Serial
10	CLOCK	I	Clock input
11	DS	I	Serial data input
12	Q7	O	Output 7
13	P5	I	Parallel data input 5
14	P6	I	Parallel data input 6
15	P7	I	Parallel data input 7
16	VDD	—	Power supply (+)

Truth table

CLOCK	D	RESET	Q0	Q1	Q2	Q3
↓	L	L	L	Q0	Q1	Q2
↓	H	L	H	Q0	Q1	Q2
↓	X	L	No Change			
X	X	H	L	L	L	L

CLOCK	DS	P/S	Dm	Qm*
↓	X	H	L	L
↓	X	H	H	H

X: Don't Care
*: Q6, Q7, Q8: outside

X: Don't Care

●Description of BU4094BC series model

Function: Dual 4-bit static shift register

1)Description of operation

BU4094BC is an 8-stage shift/store register provided in each stage with a data latch with 3-state output. Data read into shift register is read into the latch during the fall time of asynchronous STROBE input, and in the data transfer mode, output can be held. Data is passed through the latch and outputted when the STROBE is in "H" level. Because the parallel output becomes high impedance when the OUTPUT ENABLE terminal is set to "L" level by 3-state, the parallel output can be connected directly with the 8-bit pass line.

PIN arrangement

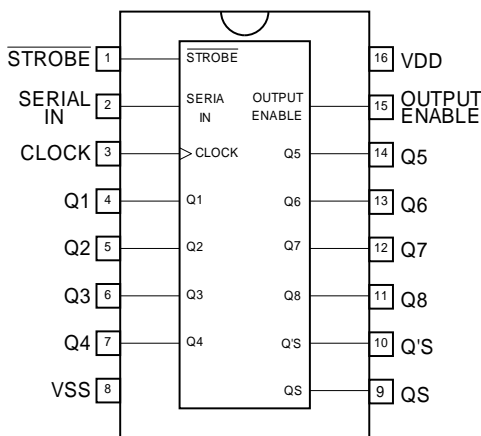

PIN description

PIN No.	Symbol	I/O	Function
1	STROBE	I	Latch input
2	SERIALIN	I	Data input
3	CLOCK	I	Clock input
4	Q1	O	Parallel data input Q1
5	Q2	O	Parallel data input Q2
6	Q3	O	Parallel data input Q3
7	Q4	O	Parallel data input Q4
8	VSS	—	Power supply(-)
9	Q5	O	Serial data output Q5
10	Q'S	O	Serial data output Q'S
11	Q8	O	Parallel data output Q8
12	Q7	O	Parallel data output Q7
13	Q6	O	Parallel data output Q6
14	Q5	O	Parallel data output Q5
15	ENABLE	I	Output enable
16	VDD	—	Power supply (+)

Block diagram

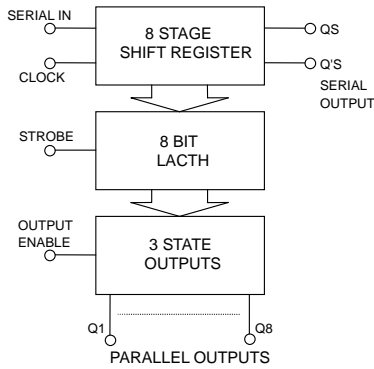

Truth table

CLOCK	OUTPUT ENABLE	STROBE	SERIAL IN	Parallel Output		Serial Output	
				Q1	Qn-1	Qs	Q's
↓	H	H	L	L	Qn-1	Q7	NC
↓	H	H	H	H	Qn-1	Q7	NC
↓	H	L	X	NC	NC	Q7	NC
↓	L	X	X	Z	Z	Q7	NC
↓	H	X	X	NC	NC	NC	Qs
↓	H	H	X	Z	Z	NC	Qs

○ Switching characteristics

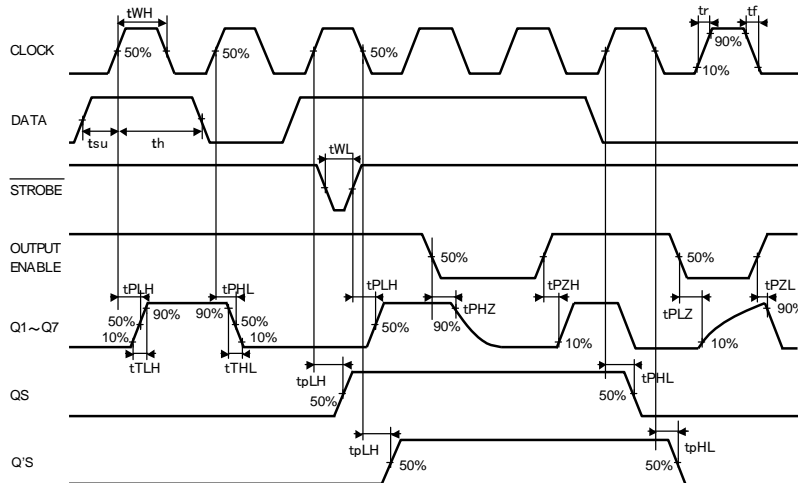

● Description of BU4538B series model

Function: Dual high accuracy monostable multivibrator

1) Description of operation

BU4538B is a re-triggerable monostable multi vibrator. Triggering is possible from either edge of the rise time and fall time of input pulse. Output pulse setting is determined by the time constant ($R_x \cdot C_x$) of external R_x and C_x .

Recommended output pulse amplitude is 200[μ s]~1[s].

(Cautions on use: In case of system power down, etc., electric charge accumulated in the capacity C_x is discharged to the VDD terminal through protective diode of 2 pins of 14 pins. When the electric current due to accumulated electric charge exceeds 10[mA], IC may be destructed. When a large capacity C_x is used, electric current flowing into the IC can be restricted by inserting the diode D_x .)

PIN arrangement

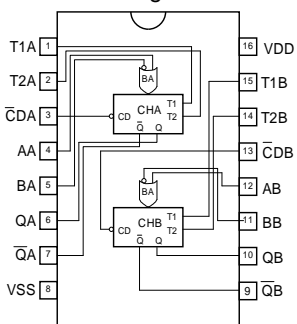

Block diagram

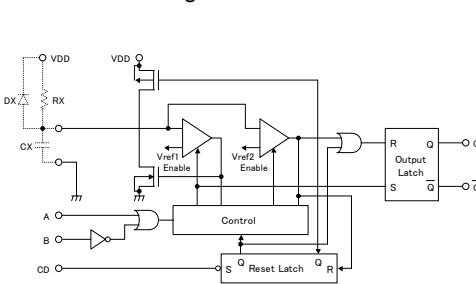

Truth table

INPUT			OUTPUT	
A	B	CD	Q	\bar{Q}
↓	H	H	↓	↑
↓	L	H	L	H
H	↓	H	L	H
L	↓	H	↓	↑
X	H	L	L	H

X: Don't Care

PIN description

PIN No.	Symbol	I/O	Function
1	T1A	—	Passive component connection pin 1(CHA)
2	T2A	—	Passive component connection pin 2(CHA)
3	CDA	I	Reset input (CHA)
4	AA	I	Input A(CHA)
5	BA	I	Input B(CHA)
6	QA	O	Output Q(CHA)
7	QAB	O	Output QB(CHA)
8	VSS	—	Power supply(-)
9	QBB	O	Output QB(CHB)
10	QB	O	Output Q(CHB)
11	BB	I	Input B(CHB)
12	AB	I	Input A(CHB)
13	CCB	I	Reset input (CHB)
14	T2B	—	Passive component connection pin 1(CHB)
15	T1B	—	Passive component connection pin 2(CHB)
16	VDD	—	Power supply (+)

● Ordering part number

B	U		4	0	1	5	B		F	V	-	E	2
Part No.		Part No.						Package			Packaging and forming specification		
		4015B		4538B				None: DIP16			E2: Embossed tape and reel		
		4021B		4028B				F : SOP16			None: Tray, Tube		
		4094BC						FV : SSOP-B16					

SOP16

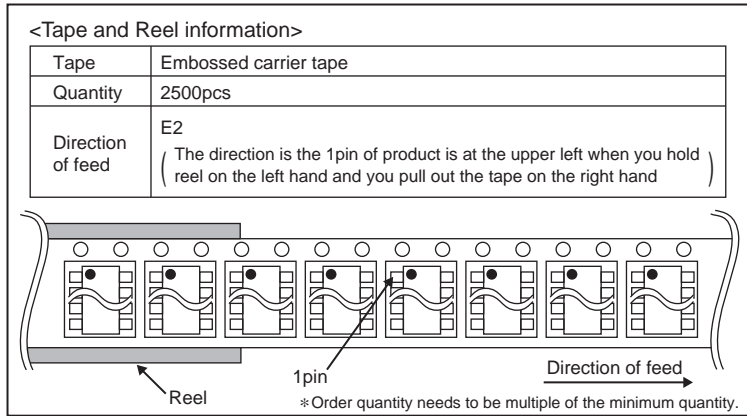
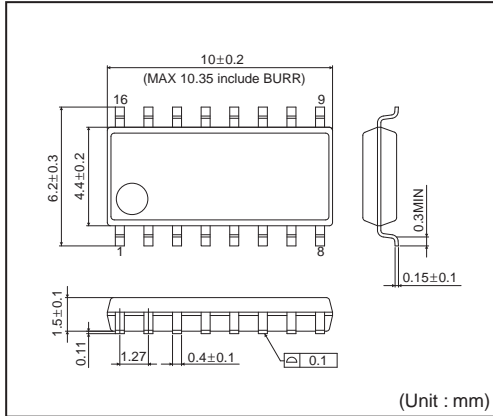

SSOP-B16

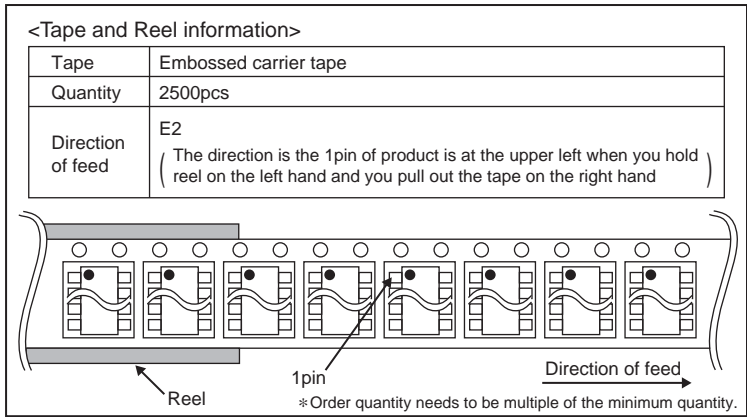
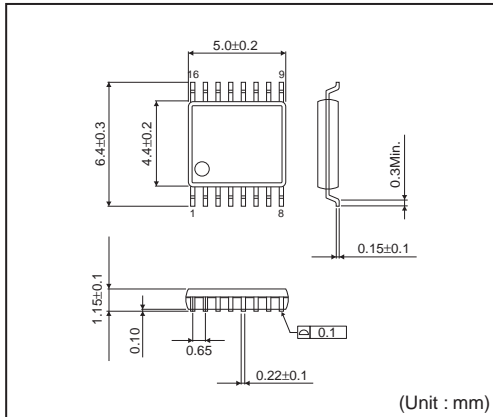

DIP16

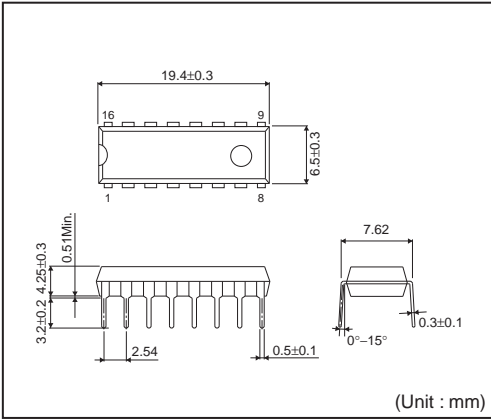

<Tape and Reel information>

Container	Tube
Quantity	1000pcs
Direction of feed	Direction of products is fixed in a container tube

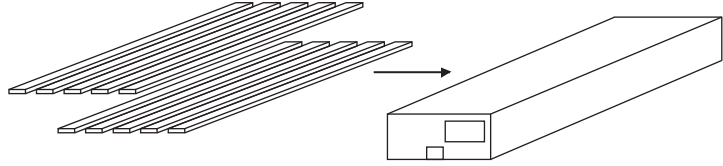

* Order quantity needs to be multiple of the minimum quantity.

Notice

Precaution on using ROHM Products

- Our Products are designed and manufactured for application in ordinary electronic equipments (such as AV equipment, OA equipment, telecommunication equipment, home electronic appliances, amusement equipment, etc.). If you intend to use our Products in devices requiring extremely high reliability (such as medical equipment ^(Note 1), transport equipment, traffic equipment, aircraft/spacecraft, nuclear power controllers, fuel controllers, car equipment including car accessories, safety devices, etc.) and whose malfunction or failure may cause loss of human life, bodily injury or serious damage to property ("Specific Applications"), please consult with the ROHM sales representative in advance. Unless otherwise agreed in writing by ROHM in advance, ROHM shall not be in any way responsible or liable for any damages, expenses or losses incurred by you or third parties arising from the use of any ROHM's Products for Specific Applications.

(Note1) Medical Equipment Classification of the Specific Applications

JAPAN	USA	EU	CHINA
CLASS III	CLASS III	CLASS II b	CLASS III
CLASS IV		CLASS III	

- ROHM designs and manufactures its Products subject to strict quality control system. However, semiconductor products can fail or malfunction at a certain rate. Please be sure to implement, at your own responsibilities, adequate safety measures including but not limited to fail-safe design against the physical injury, damage to any property, which a failure or malfunction of our Products may cause. The following are examples of safety measures:
 - Installation of protection circuits or other protective devices to improve system safety
 - Installation of redundant circuits to reduce the impact of single or multiple circuit failure
- Our Products are designed and manufactured for use under standard conditions and not under any special or extraordinary environments or conditions, as exemplified below. Accordingly, ROHM shall not be in any way responsible or liable for any damages, expenses or losses arising from the use of any ROHM's Products under any special or extraordinary environments or conditions. If you intend to use our Products under any special or extraordinary environments or conditions (as exemplified below), your independent verification and confirmation of product performance, reliability, etc. prior to use, must be necessary:
 - Use of our Products in any types of liquid, including water, oils, chemicals, and organic solvents
 - Use of our Products outdoors or in places where the Products are exposed to direct sunlight or dust
 - Use of our Products in places where the Products are exposed to sea wind or corrosive gases, including Cl₂, H₂S, NH₃, SO₂, and NO₂
 - Use of our Products in places where the Products are exposed to static electricity or electromagnetic waves
 - Use of our Products in proximity to heat-producing components, plastic cords, or other flammable items
 - Sealing or coating our Products with resin or other coating materials
 - Use of our Products without cleaning residue of flux (even if you use no-clean type fluxes, cleaning residue of flux is recommended); or Washing our Products by using water or water-soluble cleaning agents for cleaning residue after soldering
 - Use of the Products in places subject to dew condensation
- The Products are not subject to radiation-proof design.
- Please verify and confirm characteristics of the final or mounted products in using the Products.
- In particular, if a transient load (a large amount of load applied in a short period of time, such as pulse. is applied, confirmation of performance characteristics after on-board mounting is strongly recommended. Avoid applying power exceeding normal rated power; exceeding the power rating under steady-state loading condition may negatively affect product performance and reliability.
- De-rate Power Dissipation (Pd) depending on Ambient temperature (Ta). When used in sealed area, confirm the actual ambient temperature.
- Confirm that operation temperature is within the specified range described in the product specification.
- ROHM shall not be in any way responsible or liable for failure induced under deviant condition from what is defined in this document.

Precaution for Mounting / Circuit board design

- When a highly active halogenous (chlorine, bromine, etc.) flux is used, the residue of flux may negatively affect product performance and reliability.
- In principle, the reflow soldering method must be used; if flow soldering method is preferred, please consult with the ROHM representative in advance.

For details, please refer to ROHM Mounting specification

Precautions Regarding Application Examples and External Circuits

1. If change is made to the constant of an external circuit, please allow a sufficient margin considering variations of the characteristics of the Products and external components, including transient characteristics, as well as static characteristics.
2. You agree that application notes, reference designs, and associated data and information contained in this document are presented only as guidance for Products use. Therefore, in case you use such information, you are solely responsible for it and you must exercise your own independent verification and judgment in the use of such information contained in this document. ROHM shall not be in any way responsible or liable for any damages, expenses or losses incurred by you or third parties arising from the use of such information.

Precaution for Electrostatic

This Product is electrostatic sensitive product, which may be damaged due to electrostatic discharge. Please take proper caution in your manufacturing process and storage so that voltage exceeding the Products maximum rating will not be applied to Products. Please take special care under dry condition (e.g. Grounding of human body / equipment / solder iron, isolation from charged objects, setting of Ionizer, friction prevention and temperature / humidity control).

Precaution for Storage / Transportation

1. Product performance and soldered connections may deteriorate if the Products are stored in the places where:
 - [a] the Products are exposed to sea winds or corrosive gases, including Cl₂, H₂S, NH₃, SO₂, and NO₂
 - [b] the temperature or humidity exceeds those recommended by ROHM
 - [c] the Products are exposed to direct sunshine or condensation
 - [d] the Products are exposed to high Electrostatic
2. Even under ROHM recommended storage condition, solderability of products out of recommended storage time period may be degraded. It is strongly recommended to confirm solderability before using Products of which storage time is exceeding the recommended storage time period.
3. Store / transport cartons in the correct direction, which is indicated on a carton with a symbol. Otherwise bent leads may occur due to excessive stress applied when dropping of a carton.
4. Use Products within the specified time after opening a humidity barrier bag. Baking is required before using Products of which storage time is exceeding the recommended storage time period.

Precaution for Product Label

QR code printed on ROHM Products label is for ROHM's internal use only.

Precaution for Disposition

When disposing Products please dispose them properly using an authorized industry waste company.

Precaution for Foreign Exchange and Foreign Trade act

Since our Products might fall under controlled goods prescribed by the applicable foreign exchange and foreign trade act, please consult with ROHM representative in case of export.

Precaution Regarding Intellectual Property Rights

1. All information and data including but not limited to application example contained in this document is for reference only. ROHM does not warrant that foregoing information or data will not infringe any intellectual property rights or any other rights of any third party regarding such information or data. ROHM shall not be in any way responsible or liable for infringement of any intellectual property rights or other damages arising from use of such information or data.:
2. No license, expressly or implied, is granted hereby under any intellectual property rights or other rights of ROHM or any third parties with respect to the information contained in this document.

Other Precaution

1. This document may not be reprinted or reproduced, in whole or in part, without prior written consent of ROHM.
2. The Products may not be disassembled, converted, modified, reproduced or otherwise changed without prior written consent of ROHM.
3. In no event shall you use in any way whatsoever the Products and the related technical information contained in the Products or this document for any military purposes, including but not limited to, the development of mass-destruction weapons.
4. The proper names of companies or products described in this document are trademarks or registered trademarks of ROHM, its affiliated companies or third parties.

General Precaution

1. Before you use our Products, you are requested to carefully read this document and fully understand its contents. ROHM shall not be in any way responsible or liable for failure, malfunction or accident arising from the use of any ROHM's Products against warning, caution or note contained in this document.
2. All information contained in this document is current as of the issuing date and subject to change without any prior notice. Before purchasing or using ROHM's Products, please confirm the latest information with a ROHM sales representative.
3. The information contained in this document is provided on an "as is" basis and ROHM does not warrant that all information contained in this document is accurate and/or error-free. ROHM shall not be in any way responsible or liable for any damages, expenses or losses incurred by you or third parties resulting from inaccuracy or errors of or concerning such information.

X-ON Electronics

Largest Supplier of Electrical and Electronic Components

Click to view similar products for [Counter Shift Registers](#) category:

Click to view products by [ROHM](#) manufacturer:

Other Similar products are found below :

[5962-8956101EA](#) [MC10E446FNG](#) [74HC195N](#) [74HC4516N](#) [74HCT182N](#) [HEF4021BD](#) [HEF4534BP](#) [MC144111P](#) [NLV74HC165ADTR2G](#)
[5962-9172201M2A](#) [MC74HC597ADG](#) [MC100EP142MNG](#) [MC100EP016AMNG](#) [5962-9172201MFA](#) [MC74HC164BDR2G](#)
[TC74HC165AP\(F\)](#) [74AHC164T14-13](#) [MC74LV594ADR2G](#) [NLV14094BDTR2G](#) [NLV74HC595ADTG](#) [MC74HC165AMNTWG](#)
[TPIC6C595PWG4](#) [74VHC164MTCX](#) [CD74HC195M96](#) [CD4073BM96](#) [CD4053BM96](#) [MM74HC595MTCX](#) [74HCT164T14-13](#)
[74HCT164S14-13](#) [74HC4094D-Q100J](#) [NLV14014BFELG](#) [NLV74HC165ADR2G](#) [NLV74HC589ADTR2G](#) [NPIC6C595D-Q100,11](#)
[NPIC6C595PW,118](#) [NPIC6C596ADJ](#) [NPIC6C596APW-Q100J](#) [NPIC6C596D-Q100,11](#) [BU4094BCF-E2](#) [BU4094BCFV-E2](#) [74HC164D14](#)
[74HC164T14-13](#) [TPIC6C596PWRG4](#) [STPIC6D595MTR](#) [STP08CP05MTR](#) [CD74HC123E](#) [74HC164D.653](#) [74HC165D.653](#)
[74HCT165D.652](#) [74HCT164D.652](#)