

M23 Connectors and cables

M23 Connectors and cables	Product Description: SAI M23 Connectors	H.2
	Contact assignment	H.7
	Technical data	H.8
	Overview	H.10
	M23 connector for signal transmission	H.12
	M23 connector for power transmission	H.18
	Moulded M23 cables	H.22
	SAI distributor M12 with M23	H.23
	SAI distributor M18 with M23	H.25
	Installation instructions – Signal connectors	H.26
	Installation instructions – Power connectors	H.31
	M23 connector	H.35

SAI M23



A comprehensive product line of connectors, distributors and cables

M23 connectors are mainly used for connecting electrical drives and servo-motors into industrial automation applications. The M23 connectors are very easy to handle and operate. In addition to the injection-moulded variants and the SAI distributors with M23 connectors, Weidmüller is now offering customisable versions and built in plugs.





The M23 built in connector

The M23 built in connector provides a custom fit solution for building directly into the device.



M23 connectors for crimping

M23 connectors are easy to handle and operate. This is supported by the type of crimping that is used.



Robust metal housing

The M23 connectors feature an extra robust design.



Solutions for power and signals

The extensive product line includes the key housing shapes, such as angled connectors, coupling connectors and device connectors.



M23 connector for signal transmission

Housings



M23 connector for signal transmission

Built in connector



M23 connector for power transmission

Housings



M23 connector for power transmission

Built-in connector



Moulded M23 cables



SAI distributors



Product Description: SAI M23 Connectors

Technology and requirements

The M23 connectors are mainly used for integrating electrical drives and servo motors into industrial automation facilities. The M23 designation is based on the thread diameter of the connector, as shown in Figures 1 and 2.

With their wide variety of inserts and housings, these connector are equally suited for applications involving signal or power transmission. Applications set in harsh industrial environments place strict requirements on the connector. Much is demanded of the housing, the inner insert and the connector contact as well. Thermal loads, physical loads, and loads from the transmitted electrical power are commonplace. M23 connectors are capable of carrying a load of up to 250/630 V at 9/30 A.

The connectors must be resistant to the penetration of all particles and substances. They must also comply with the required class of IP protection. The material used for manufacture must be resistant to acid and alkaline solutions that may be used during cleaning or production processes. Also it must not be possible for residues to accumulate in the plug which could later contaminate the production flow. It must not be possible for the plug components to loosen due to vibration. In addition, the cable and connector must have EMC shielding for some applications. This keeps external interference from influencing the signals and it also prevents the transmitted signals in the cable from interfering with other cables or components. The standards and directives (such as the German or European standards) that are followed are basically only recommendations concerning the composition of the connector. A so-called "cold standard" exists for the M23 connectors.

Variants and designs

The variants can be classified generally according to their outer design into either customisable types or plastic moulded connectors with pre connected cables. Both variants are available in male or female versions, and in straight or angled design. Different designs and inserts can be combined to fit the particular application so that an almost limitless variety of combinations is possible. The connector inserts are available in a variety of different pole counts and as either male or female versions. The pole counts also vary in that some contacts in the mating profile may have a larger cross-section than the others. Other types include the device connector variants which are used for contacting and connecting housings. These also come in a variety of designs. The metal alloy in use may differ depending on the particular type of application. For example, stainless steel is used for those variants that will be used in the food processing industry. Each connector is optionally available with EMC protection and a plastic surface.

Customisable connectors

The customisable connectors are almost all manufactured from metal alloys. Variants with plastic housings or fitting nuts are rare and then used mostly for customer-specific solutions. Customisable connectors are made up of a housing, a plastic contact carrier, and the contacts themselves. The various housing types can be equipped with the corresponding contact carriers. The carriers differ in their number of poles and the arrangement of the poles. Different types of contacts may also be used within the contact carriers. The shape of the contacts is either male or female. There are also difference in the width, material, and connection system (such as soldered, crimped or screwed).

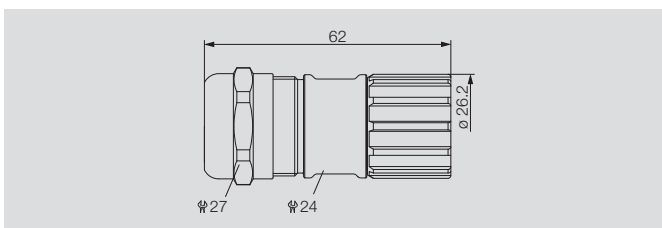

Figure 1: M23 cable connector

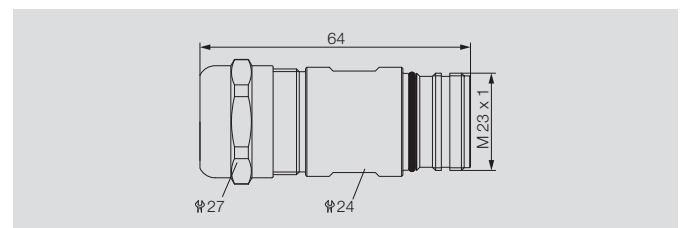

Figure 2: M23 coupling connector

This modular construction allows for a wide variety of combinations to fit any application type. Figure 3 shows the design and assembly of a M23 signal connector. Since the connector is usually put together in the field, the key requirement is that the connector is easy and reliable for the electrician to handle on-site. A good example of convenient handling is the integrated

EMC shielding. An improved shield connection results because the shielding can be connected in less steps and with fewer tools. The complete assembly process must be clear and concise, and should only take a few steps.

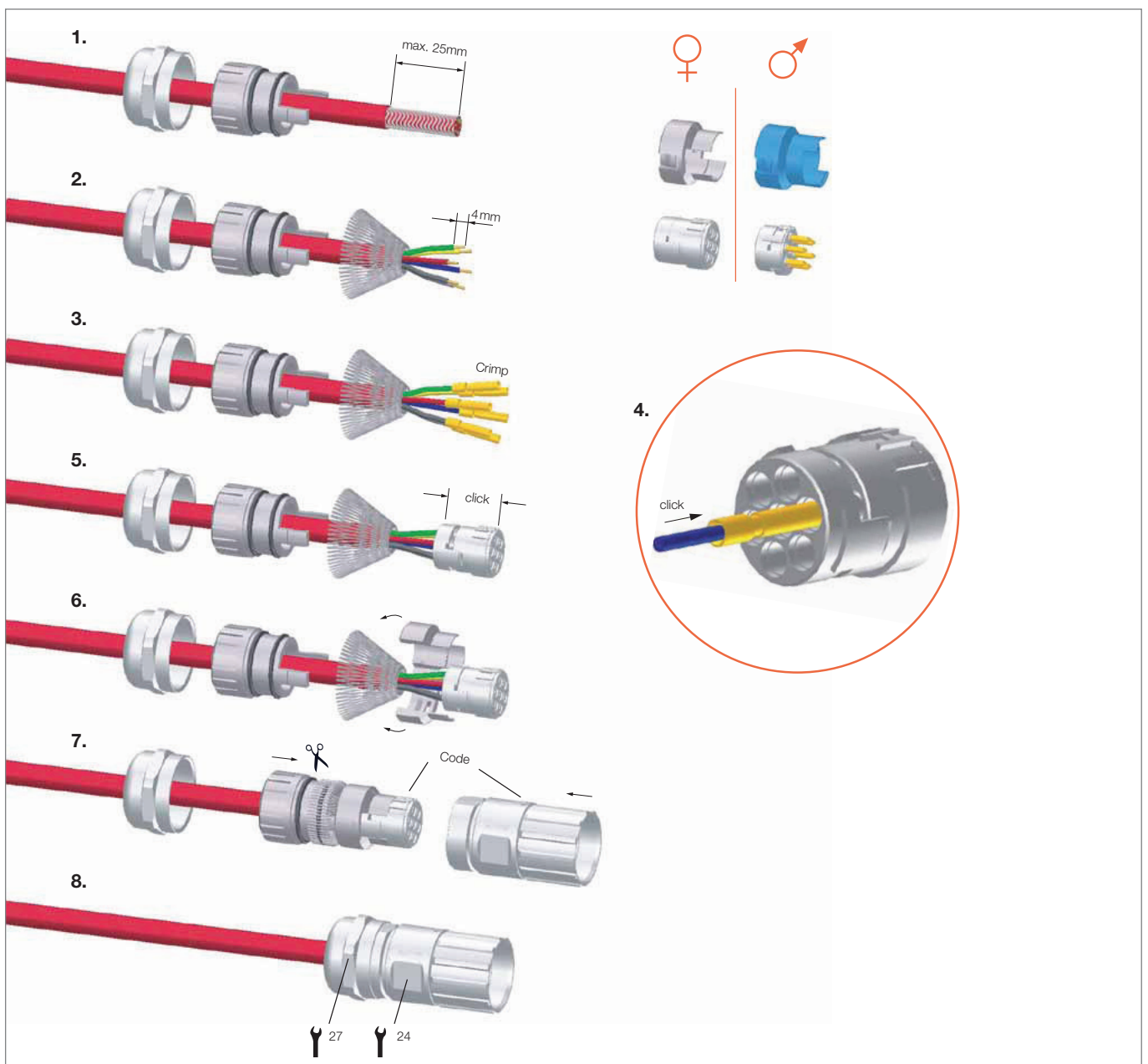

Figure 3: Design and assembly of an M23 connector

Product Description: SAI M23 Connectors

Plastic injection moulded connector with connected cable

The plastic injection moulded cables are cables that have already been fitted with connectors. First the cables are connected with the contacts and then these are mounted into the contact carrier. Next, plastic injection moulding is used to cover the cable and contact carrier with a plastic moulding. This ensures a highly stable and well sealed connector housing. The connector must be destroyed for it to be disconnected from its cable. The connector's outer form and material is arranged by a plastic processing tool.

The advantage of a moulded cable is that the connection between the cable and the connector has already been tested at



Plastic injection-moulded M23 connector

the production factory. The electrician need only adjust the length. Depending on the application, he may choose to use another connector on the open end or connect the individual cable wires directly (for example, to a terminal block). These advantages of this variant type includes the inexpensive assembly of large batches, the high degree of automation and minimal amount of material used. High reliability and an excellent seal are two additional advantages.

Connector usage and application

M23 connectors are mainly used for integrating within machine and facility construction applications. These applications require connections with a long life span and high reliability. The failure of a single connector could lead to the failure of the entire production line. It's important to avoid facility outages caused by a connector malfunction, so the machine and facility construction industry relies on connectors with the advantages listed above. Both signals and power must be transferred in such applications. The connector and the cable must be able to withstand harsh industrial conditions. Cables may be under stress from constant motion, in particular for applications involving robotics or dragline chains. Special cables with a specific maximum

bending radius are used for such applications (for example, the bending radius may be 10d, i.e., ten times the cable diameter). When constructing a facility, a variety of connection scenarios are possible based on the particular conditions or adaptations on existing facilities. The length or configuration of the cable must be adapted to fit these conditions. If space is constricted, for instance, it may be necessary to replace a straight connector with an angled one.

Cables can be equipped with both a moulded (extruded) connector and a customizable connector. This ensures proper functionality while providing the flexibility to adapt to changing conditions on location. Safe connections can thus be established with any possible connector combination or at any protective class

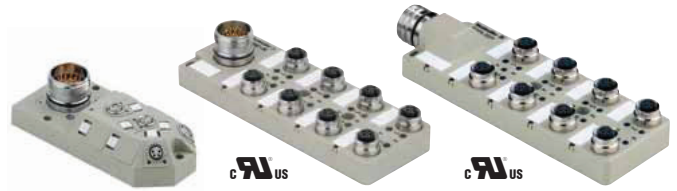

SAI distributor with M23 connector

required. This gives the facility planner the safety he needs. And the electrician on-site can set up the facility properly because he has sufficient flexibility to adapt to uncertain conditions. For sensor systems, connectors with high pole counts are often used on SAI distributors. Individual sensors are connected to the distributors where the signals are then centralized. They are then transferred to the controller using a cable with an M23 connector. The most common use for transmitting power involves the connection of servo-motors in machines. M23 connectors are used for this purpose because of their sturdy and compact design and their high power-carrying capacities. Because of the size of the M23 connector, it can also be used in a hybrid version for transmitting both signals and power. The signal-carrying contacts are then shielded within the connector to ensure that the transmitted voltages do not interfere with the signals.

Contact assignment SAI M23

M23 12- and 19-pole, for SAI distributors and cables

12-pole

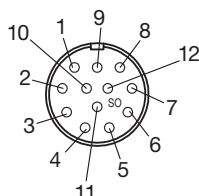
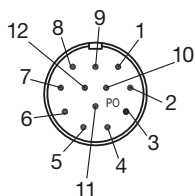

Pole	Colour code	Plug-in station	Contact M12
1	white	1	4
2	green	2	4
3	yellow	3	4
4	grey	4	4
5	pink	5	4
6	red	6	4
7	black	7	4
8	violet	8	4
9	blue (-)	1-8	3
10	blue (-)	1-8	3
11	brown (+)	1-8	1
12	green-yellow (PE)	1-8	5

19-pole

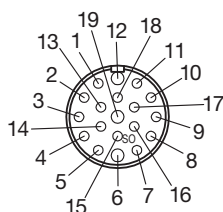
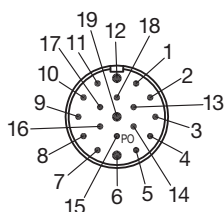

Pole	Colour code	Plug-in station	Contact M12
1	violet	8	4
2	red	6	4
3	grey	4	4
4	red/blue	2	2
5	green	2	4
7	grey/pink	1	2
8	white/green	3	2
9	white/yellow	5	2
10	white/grey	7	2
11	black	7	4
13	yellow/brown	6	2
14	brown/green	4	2
15	white	1	4
16	yellow	3	4
17	pink	5	4
18	grey/brown	8	2
6	blue (-)	1-8	3
12	green-yellow (PE)	1-8	5
19	brown (+)	1-8	1

Description code

Housing	
G	Inner thread
K	Outer thread
W	angled
S	Signal connectors
L	Power connectors
7/12	Cable passage
Inserts	
BE	Female insert
SE	Male insert
4/4	Number of contacts, here for 4 sensor and 4 power contacts
Contacts	
KBC	Female contact
Wire cross-section	
0.08/0.56	0.08 mm ² – 0.56 mm ²
0.25/1.0	0.25 mm ² – 1.0 mm ²
0.75/2.5	0.75 mm ² – 2.5 mm ²
Moulded M23 cables	
SAIS	Cable with male plug
SAIB	Cable with female plug
12p	12-pole
19p	19-pole
AN	angled
ST	straight
...M	Length in metres

Contact partitioning

Signal connectors			
Type	1 mm contact	1.5 mm contact	2 mm contact
6-pole			6
7-pole			7
9-pole	8		1
12-pole	12		
16-pole	16		
17-pole	17		
19-pole	16	3	
Power connectors			
Type	1 mm contact	1.5 mm contact	2 mm contact
6-pole			6
4+4-pole	4		4

Contacts for signal plugs cannot be used in inserts for power plugs and vice versa.

Technical data

Signal connectors

Technical data

Mechanical data										
Housing		Copper-Zinc alloy Die Casting								
Housing surface		Nickel plated brass other surface upon request								
Inserts (for contacts)		Thermoplastic Polyamid PA 6 (Nylon 6/6), PBT / Fire protection class V-0								
Contacts		Brass Alloy								
Contact surface at point of contact		Nickel and gold plated (0.25 µm Au)								
Minimum mating cycles		> 1000								
Seals / O-Rings		Buna-N standard optional Viton® (Viton is a registered trademark of DuPont)								
Temperature range		-40 °C – 125 °C								
Type of contacts		Crimp, solder, dip-solder (PCB)								
Protection		IP 67 / IP 69 K per EN 60 529 (connected)								
Cable diameter range		3 – 17 mm								
Electrical Data										
Number of positions		6	7	9	12	16	17	19		
Number of contacts		6	7	8	1	12	16	17	16	3
Contact-Ø	mm	2	2	1	2	1	1	1	1	1.5
Nominal current	A	20	20	8	20	8	8	8	8	10
Nominal voltage at pollution degree 2	V~	630	630	500	500	400	400	400	320	
Nominal voltage at pollution degree 3	V~	300	300	200	200	160	160	160	100	
Test voltage	V~	2500	2500	2500	2500	1500	1500	1500	1500	
Insulation resistance	MΩ	> 10 ¹⁰	> 10 ¹⁰	> 10 ¹⁰	> 10 ¹⁰	> 10 ⁶	> 10 ⁶	> 10 ⁶	> 10 ⁶	
Max. contact resistance	mΩ	3	3	3	3	3	3	3	3	

Derating curve

Straight Connectors male + female M 23, 12-pole,
wires 12 x AWG17

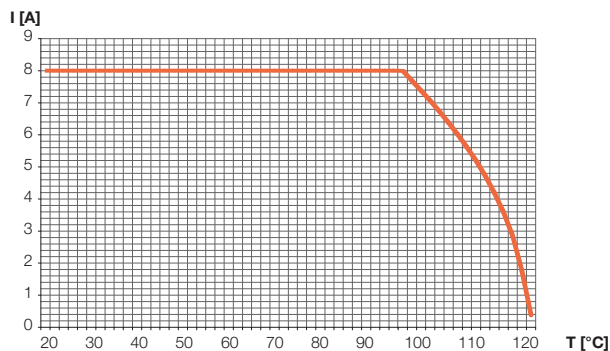

Power connectors

Technical data

Mechanical data	
Housing	Copper-Zinc alloy Die Casting
Housing surface	Nickel plated brass other surface upon request
Inserts (for contacts)	Thermoplastic Polyamid PA 6 (Nylon 6/6), PBT / Fire protection class V-0
Contacts	Brass Alloy
Contact surface at point of contact	Nickel and gold plated (0.25 µm Au)
Minimum mating cycles	> 1000
Seals / O-Rings	Buna-N standard optional Viton® (Viton is a registered trademark of DuPont)
Temperature range	-40 °C – 125 °C
Type of contacts	Crimp
Protection	IP 67 / IP 69 K per EN 60 529 (connected)
Cable diameter range	7 – 17 mm

Electrical Data		5 + PE		4/4	
Number of positions		5 + PE		4/4	
Number of contacts		6		4	4
Contact-Ø	mm	2		1	2
Nominal current	A	28		8	28
Nominal voltage at pollution degree 2	V~	800		300	800
Nominal voltage at pollution degree 3	V~	600		300	600
Test voltage	V~	4000		2500	4000
Insulation resistance	MΩ	> 10 ¹³		> 10 ¹³	
Max. Max. contact resistance	mΩ	3		3	

Derating curve



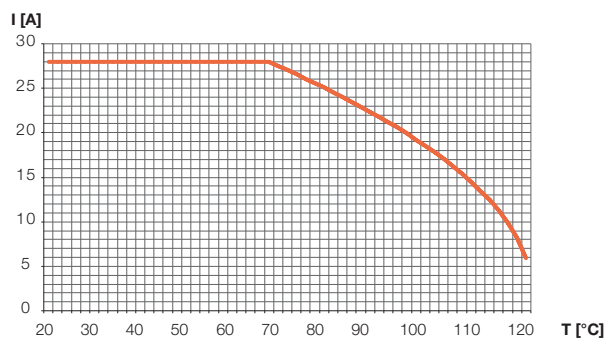























Straight connectors male + female M 23, 5 + PE,
wires 5 x AWG12





















Overview

M23 connector for signal transmission

All customizable connectors can also be assembled together with shielded cables.

Housing	Contact inserts*	Contacts
Cable connector 	6-pole 	Crimp pin 1 mm rotated 0.08 – 0.56 mm ² 
Coupling connector 	7-pole 	Crimp pin 1 mm rotated 0.14 – 1.00 mm ² 
Angled connector 	9-pole 	Crimp pin 1 mm rotated 1.00 – 1.50 mm ² 
Angled connector (coupling) 	12-pole 	Crimp socket 1 mm rotated 0.08 – 0.56 mm ² 
Device connector (front panel) 	16-pole 	Crimp socket 1 mm rotated 0.14 – 1.00 mm ² 
Device connector with knurled nut 	17-pole 	Crimp socket 1 mm rotated 1.00 – 1.50 mm ² 
Device connector (single-hole mount) 	19-pole 	Crimp pin 2 mm rotated 0.14 – 0.56 mm ² 
Device connector (angled) 		Crimp socket 2 mm rotated 0.56 – 1.00 mm ² 
Device connector (back panel) 		Crimp pin 2 mm rotated 0.75 – 2.50 mm ² 
		Crimp socket 2 mm rotated 0.75 – 2.50 mm ² 
	* Solder and crimp inserts	

M23 connector for power transmission

Housing	Contact inserts*	Contacts
Cable connector 	6 x Male 2 mm 	Crimp pin 1 mm turned 0.25 – 1.00 mm ² 
Coupling connector 	6 x Socket 2 mm 	Crimp socket 1 mm turned 0.25 – 1.00 mm ² 
Angled connector 	4 x Male 1 mm 4 x Male 2 mm 	Crimp pin 2 mm turned 0.75 – 2.50 mm ² 
Angled connector (coupling) 	4 x Socket 1 mm 4 x Socket 2 mm 	Crimp pin 2 mm turned 2.50 – 4.00 mm ² 
Device connector (front panel) 		Crimp socket 2 mm turned 0.75 – 2.50 mm ² 
Device connector with knurled nut 		Crimp socket 2 mm turned 2.50 – 4.00 mm ² 
Device connector (back panel) 		
Device connector (back panel) 		
Device connector (angled) 		
	* Crimp inserts	

Moulded M23 cables

Housing
Cable connector
Coupling connector
Angled connector
Angled connector (coupling)



M23 connector for signal transmission

Housing

For cables with outer diameter of: 7–12 mm

Cable connector

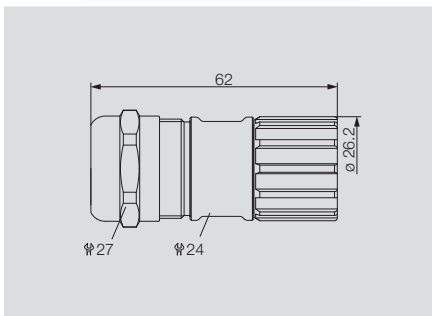

Coupling connector

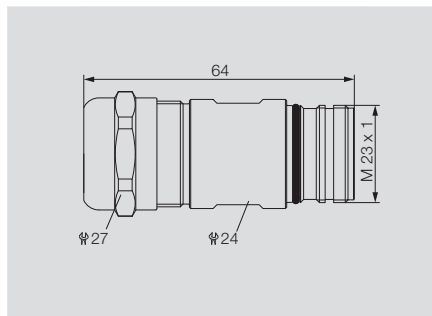

Ordering data

Type	Qty.	Order No.
SAI-M23-GS-7/12	1	1995840000

Ordering data

Type	Qty.	Order No.
SAI-M23-KS-7/12	1	1169900000

Angled connector

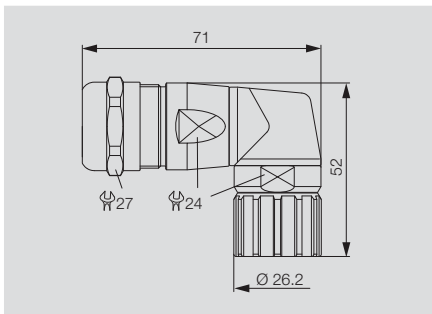

Angled connector (coupling)

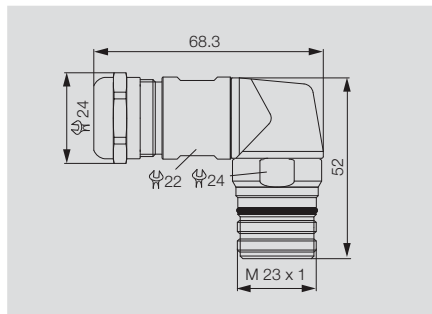

Ordering data

Type	Qty.	Order No.
SAIL-M23-GS-S-7/12	1	1169920000

Ordering data

Type	Qty.	Order No.
SAIL-M23-KSW-7/12	1	1169930000

Built-in connector

With 3.2-mm mounting holes

Device connector (front panel)

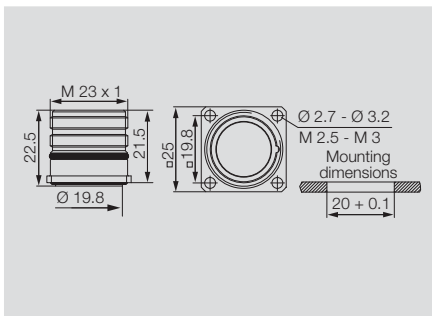

Ordering data

Type	Qty.	Order No.
SAIE-M23-S-VW	1	1169940000

Device connector with knurled nut

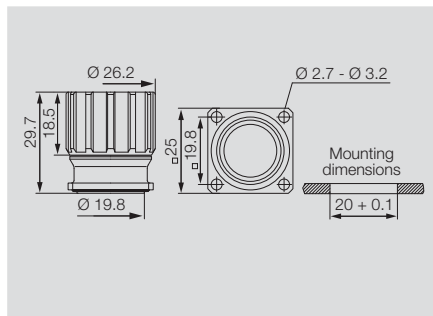

Ordering data

Type	Qty.	Order No.
SAIE-M23-S-RM	1	1169950000

Device connector (single-hole mount)

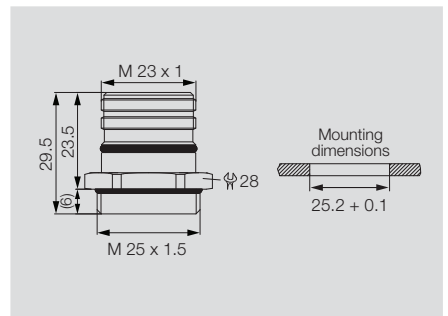

Ordering data

Type	Qty.	Order No.
SAIE-M23-S-EM	1	1169970000

H

Device connector (angled)

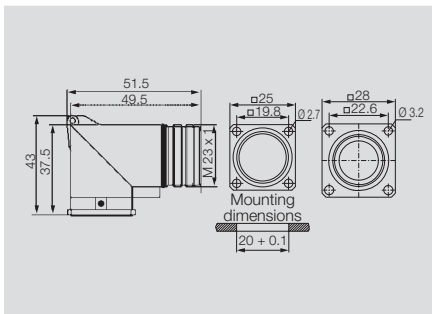

Ordering data

Type	Qty.	Order No.
SAIE-M23-S-W	1	1169980000

Device connector (back panel)

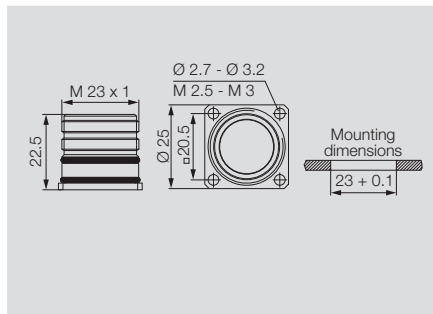

Ordering data

Type	Qty.	Order No.
SAIE-M23-S-HW	1	1169990000

M23 connector for signal transmission

Inserts

6-pole

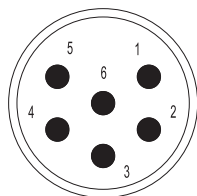
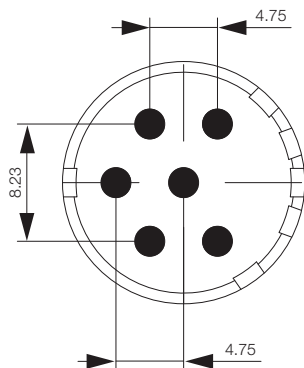

Male insert on plug side

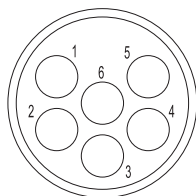

Female insert on plug side

Ordering data

	Type	Qty.	Order No.
Insert 6-pole male	SAI-M23-SE-6	1	1170000000
Insert 6-pole socket	SAI-M23-BE-6	1	1170020000

9-pole

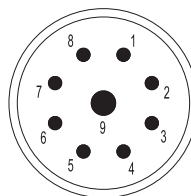
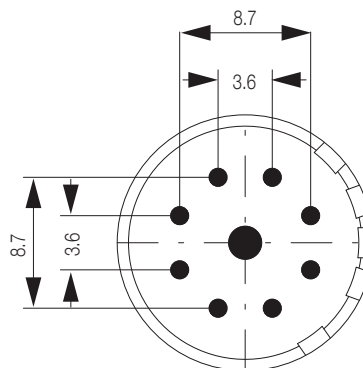

Male insert on plug side

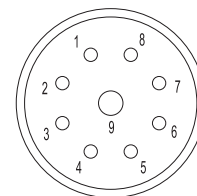

Female insert on plug side

Ordering data

	Type	Qty.	Order No.
Insert 9-pole male	SAI-M23-SE-9	1	1170050000
Insert 9-pole socket	SAI-M23-BE-9	1	1170060000

7-pole

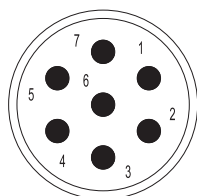
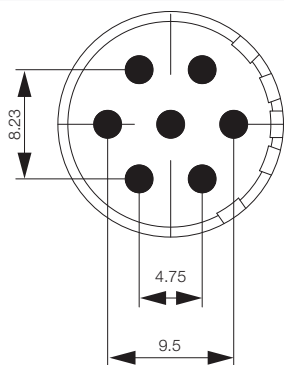

Male insert on plug side

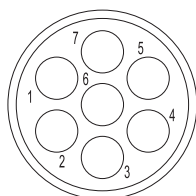

Female insert on plug side

Ordering data

	Type	Qty.	Order No.
Insert 7-pole male	SAI-M23-SE-7	1	1170030000
Insert 7-pole socket	SAI-M23-BE-7	1	1170040000

12-pole

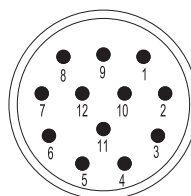
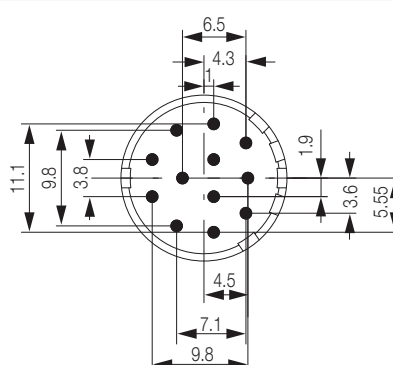

Male insert on plug side

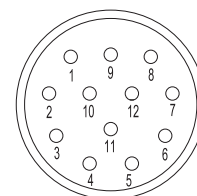

Female insert on plug side

Ordering data

	Type	Qty.	Order No.
Insert 12-pole male	SAI-M23-SE-12	1	1170070000
Insert 12-pole socket	SAI-M23-BE-12	1	1995850000

16-pole

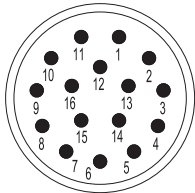
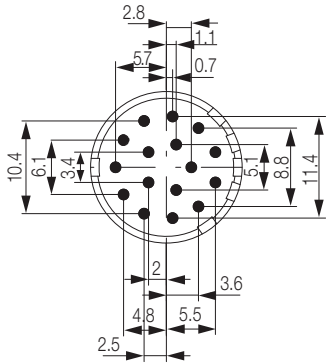

Male insert on plug side

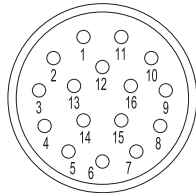

Female insert on plug side

Ordering data

	Type	Qty.	Order No.
Insert 16-pole male	SAI-M23-SE-16	1	1170080000
Insert 16-pole socket	SAI-M23-BE-16	1	1170090000

19-pole

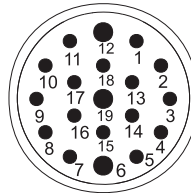
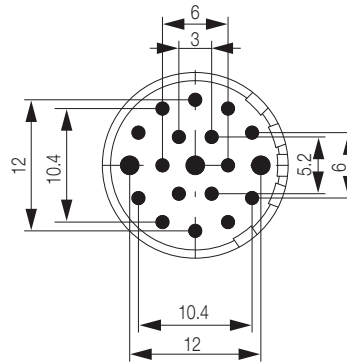

Male insert on plug side

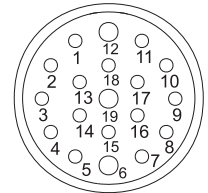

Female insert on plug side

Ordering data

	Type	Qty.	Order No.
Insert 19-pole male	SAI-M23-SE-19	1	1170120000
Insert 19-pole socket	SAI-M23-BE-19	1	1170130000

17-pole

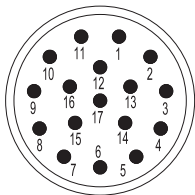
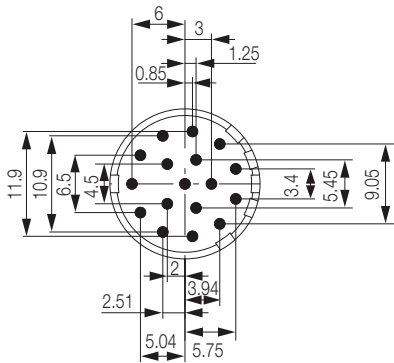

Male insert on plug side

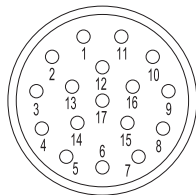

Female insert on plug side

Ordering data

	Type	Qty.	Order No.
Insert 17-pole male	SAI-M23-SE-17	1	1170100000
Insert 17-pole socket	SAI-M23-BE-17	1	1170110000

M23 connector for signal transmission

Contacts

Male, 1 mm

0.08-0.56

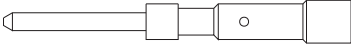

0.14-1.00

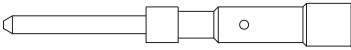

1.00-1.50

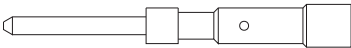

Female, 1 mm

0.08-0.56

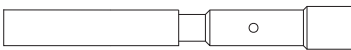

0.34-1.00

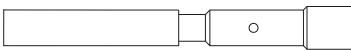

1.00-1.50

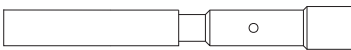

Male, 1.5 mm

0.14-1.00

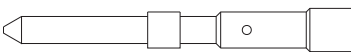

Female, 1.5 mm

0.14-0.56

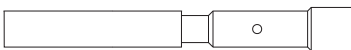

0.56-1.00

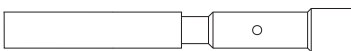

Ordering data

	Type	Qty.	Order No.
1.0 mm Male (0.08-0.56)	SAI-M23-KSC-0.08/0.56	50	1170140000

1.0 mm Male (0.14-1.00)	SAI-M23-KSC-0.14/1.00	50	1170150000
-------------------------	-----------------------	----	------------

1.0 mm Male (1.00-1.50)	SAI-M23-KSC-1.00-1.5	50	1170170000
-------------------------	----------------------	----	------------

Ordering data

	Type	Qty.	Order No.
1.0 mm Socket (0.08-0.56)	SAI-M23-KBC-0.08/0.56	50	1995860000

1.0 mm Socket (0.34-1.00)	SAI-M23-KBC-0.34/1.00	50	1170180000
---------------------------	-----------------------	----	------------

1.0 mm Male (1.00-1.50)	SAI-M23-KBC-1.00-1.5	50	1170210000
-------------------------	----------------------	----	------------

Ordering data

	Type	Qty.	Order No.
1.5 mm Male (0.14-1.00)	SAI-M23-KSC-1.5-0.14-1	50	1170220000

Ordering data

	Type	Qty.	Order No.
1.5 mm Socket (0.14-0.56)	SAI-M23-KBC-1.5-.14-.56	50	1170230000

1.5 mm Socket (0.56-1.00)	SAI-M23-KBC-1.5-.56-1.0	50	1170240000
---------------------------	-------------------------	----	------------

Male, 2 mm

0.75-2.00

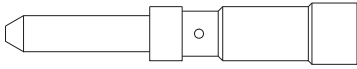

Ordering data

	Type	Qty.	Order No.
2.0 mm Male (0.75-2.00)	SAI-M23-KSC-2-0.75-2.00	50	1170250000

Female, 2 mm

0.75-2.00

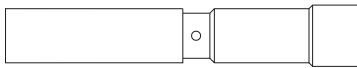

Ordering data

	Type	Qty.	Order No.
2.0 mm Socket (0.75-2.00)	SAI-M23-KBC-2-0.75-2.00	50	1170260000

Technical data

Number of positions	6	7	9	12	16	17	19			
Number of contacts	6	7	8	1	12	16	17	16	3	
Contact-Ø	mm	2	2	1	2	1	1	1	1	1.5

M23 connector for power transmission

Housing

For cables with outer diameter of: 7–12 mm

Cable connector

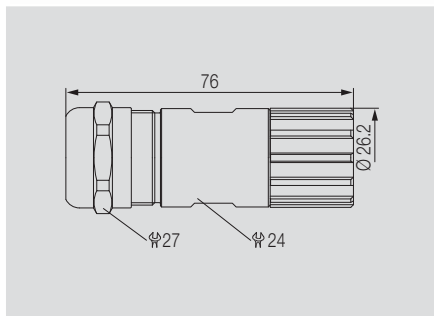

Coupling connector

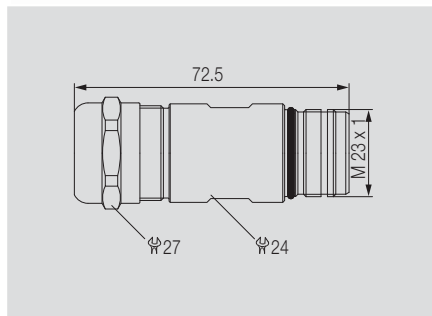

Ordering data

Type	Qty.	Order No.
SAI-M23-GS-L-7/12	1	1995800000

Ordering data

Type	Qty.	Order No.
SAI-M23-KS-L-7/12	1	1170270000

Angled connector

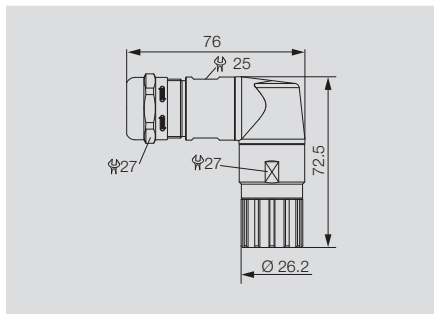

Angled connector (coupling)

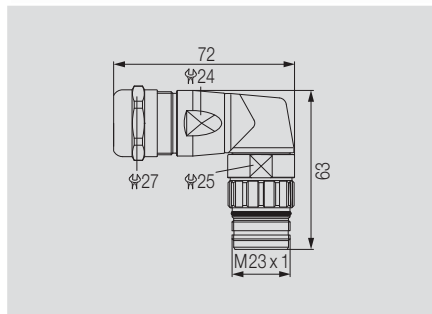

Ordering data

Type	Qty.	Order No.
SAIL-M23-GSW-L-7/12	1	1170280000

Ordering data

Type	Qty.	Order No.
SAIL-M23-KSW-L-7/12	1	1170290000

Built-in connector

With 3.2-mm mounting holes

Device connector (front panel)

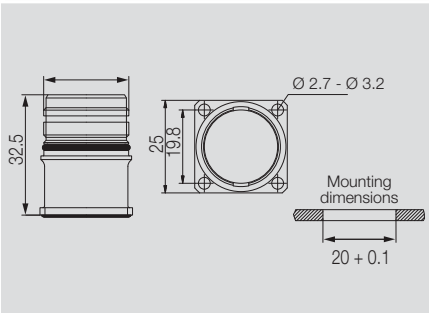

Ordering data

Type	Qty.	Order No.
SAIE-M23-L-VW	1	117030000

Device connector with knurled nut

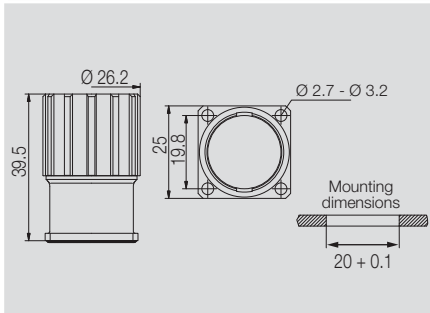

Ordering data

Type	Qty.	Order No.
SAIE-M23-L-RM	1	117031000

Device connector (single-hole mount)

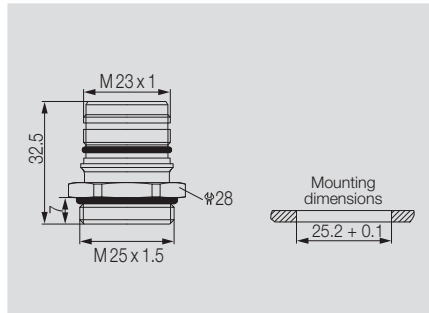

Ordering data

Type	Qty.	Order No.
SAIE-M23-L-EM	1	117032000

H

Device connector (angled)

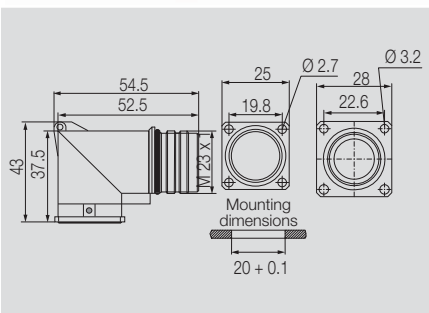

Ordering data

Type	Qty.	Order No.
SAIE-M23-L-W	1	117033000

Device connector (back panel)

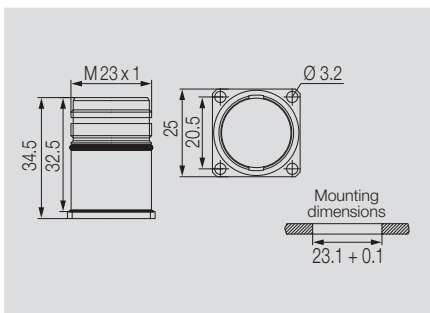

Ordering data

Type	Qty.	Order No.
SAIE-M23-L-HW	1	117034000

M23 connector for power transmission

Inserts

5 + PE

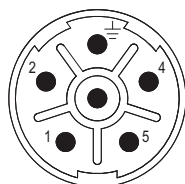
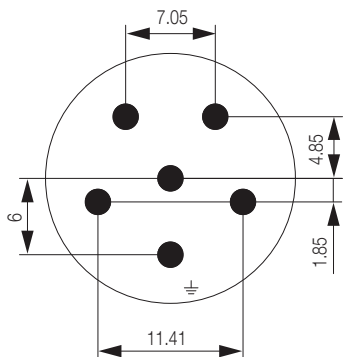

6 times male, 2 mm

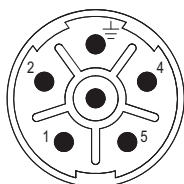

6 times female, 2 mm

4/4

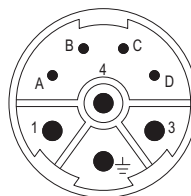
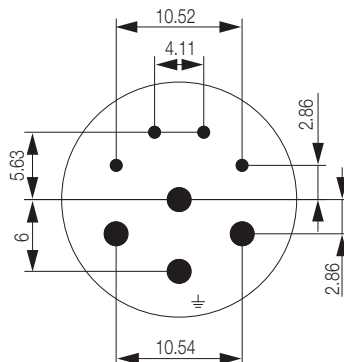

4 times 1-mm male and 4 times 2-mm male

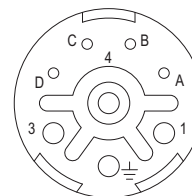

4 times 1-mm female and 4 times 2-mm female

Ordering data

	Type	Qty.	Order No.
6 times male, 2 mm	SAI-M23-SE-L-6	1	1170350000
6 times female, 2 mm	SAI-M23-BE-L-6	1	1170370000

Ordering data

	Type	Qty.	Order No.
4 times 1-mm male and 4 times 2-mm male	SAI-M23-SE-L-4/4	1	1170380000
4 times 1-mm female and 4 times 2-mm female	SAI-M23-BE-L-4/4	1	1995810000

Contacts

Male, 1 mm

0.25 - 1.00



Ordering data

	Type	Qty.	Order No.
1 mm Male (0.25-1.00)	SAI-M23-KSC-0,25-1.0	50	1170390000

Female, 1 mm

0.25 - 1.00

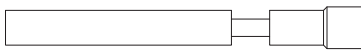

Ordering data

	Type	Qty.	Order No.
1 mm Socket (0.25-1.00)	SAI-M23-KBC-0,25-1.0	50	1995830000

Male, 2 mm

0.75 - 2.5

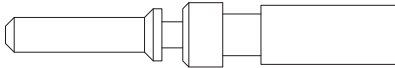

Ordering data

	Type	Qty.	Order No.
2 mm Male (0.75-2.5)	SAI-M23-KSC-L-0,75-2.5	50	1170400000

2.5 - 4.00

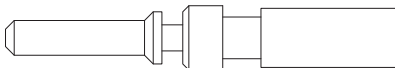

2 mm Male (2.5-4.00)	SAI-M23-KSC-L-2,5-4.0	50	1170410000
----------------------	-----------------------	----	------------

Female, 2 mm

0.75 - 2.5

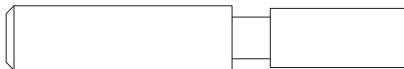

Ordering data

	Type	Qty.	Order No.
2 mm Socket (0.75-2.5)	SAI-M23-KBC-L-0,75-2,5	50	1995820000

2.5 - 4.00



2 mm Socket (2.5-4.00)	SAI-M23-KBC-L-2,5-4,0	50	1170420000
------------------------	-----------------------	----	------------

Technical data

Number of positions	5 + PE	4/4	
Number of contacts	6	4	4
Contact-Ø	mm	2	2

Moulded M23 cables

M23 cables

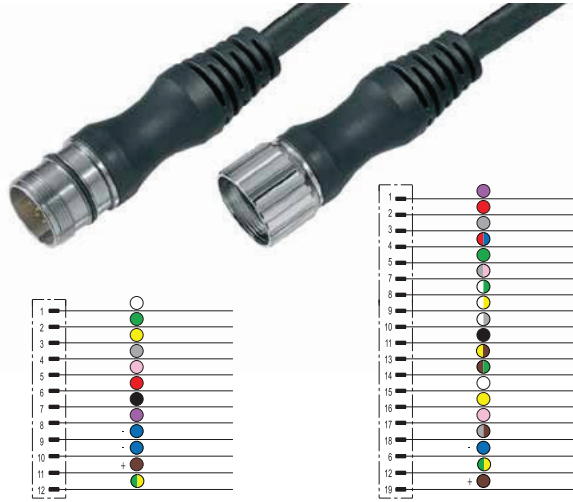
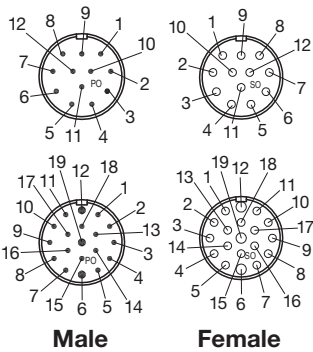

Ordering data

Male, straight	1 m
Male, angled	1 m
Female, straight	1 m
Female, angled	1 m
Note	

12-pole	
Type	Order No.
SAIS-M23-12P-AN-1,0M	1906290100
SAIS-M23-12P-ST-1,0M	1906280100
SAIB-M23-12P-AN-1,0M	1877440100
SAIB-M23-12P-ST-1,0M	1886440100

ST = straight
AN = 90° elbow

19-pole	
Type	Order No.
SAIS-M23-19P-AN-1,0M	1818090100
SAIS-M23-19P-ST-1,0M	1818160100
SAIB-M23-19P-AN-1,0M	1818140100
SAIB-M23-19P-ST-1,0M	1818180100

Other versions on request

Standard cable lengths

All cables listed under the ordering data have a length of 1.5 metres. The last four ordering digits must be changed when ordering other standard cable lengths.	1.5 m	xxxxxx0150
	3.0 m	xxxxxx0300
	5.0 m	xxxxxx0500
	10.0 m	xxxxxx1000

Technical data

Rated current	8 A
Protection class	IP 67
Core cross-section	0.75 mm ²
Contact surface	gold-plated
Temperature range of housing	-25...+85 °C
Rated voltage	150 V
(acc. to VDE standard 0110 ISO group C)	

Chapter W includes additional technical specifications for the cable

Dimensioned drawing

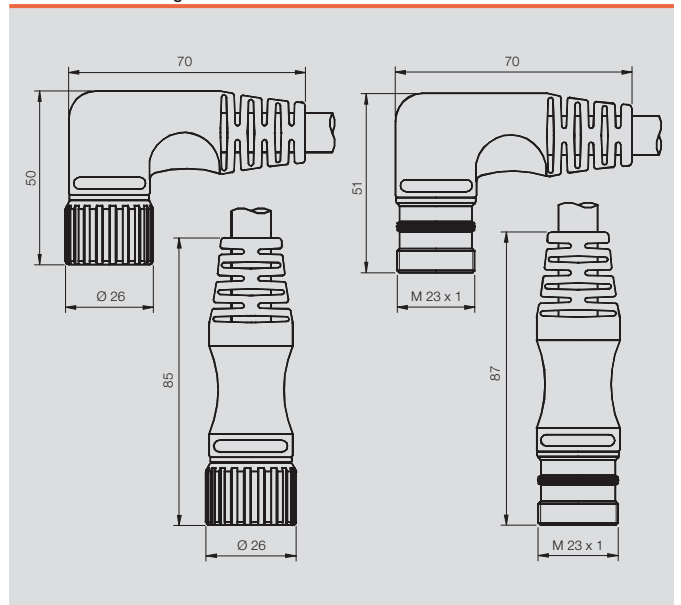

with M23 outlet

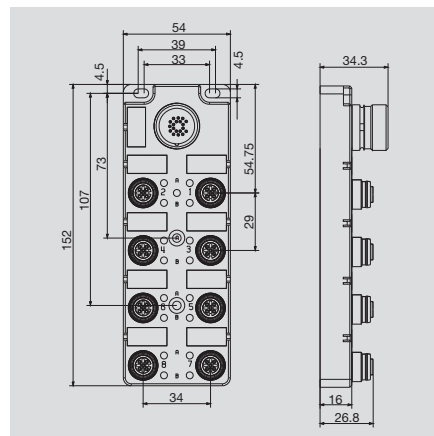

Ordering data

Complete modules	
	4 channel
	8 channel
Note	

SAI-4/8-S

4-pole

Type	Qty.	Order No.
SAI-4-S 4P FC	1	1847960000
SAI-8-S 4P FC	1	1847920000
Other versions on request		

SAI-4/8-S

5-pole

Type	Qty.	Order No.
SAI-4-S 5P FC	1	1847970000
SAI-8-S 5P FC	1	1848040000
Other versions on request		

Technical data

Operating voltage	10...30 V
Current of continuous busbars	2 A
max. current-carrying capacity per slot	4 A
Total current	9 A
Pollution severity	3
Protection class	IP 67
Ambient temperature range	-25...+80 °C
Housing main material	PA 6 GF
Contact carrier material	PBT UL 94 V0
Base material of contacts	CuZn, pre-nickeled, gold-plated
screw socket	CuZn, nickel-plated
Housing colour	grey, RAL 7032
Flammability class UL 94	V-0
Clamping range of hood-version	
Suitable for dragline cable (fixed cable connection)	

Wiring diagram

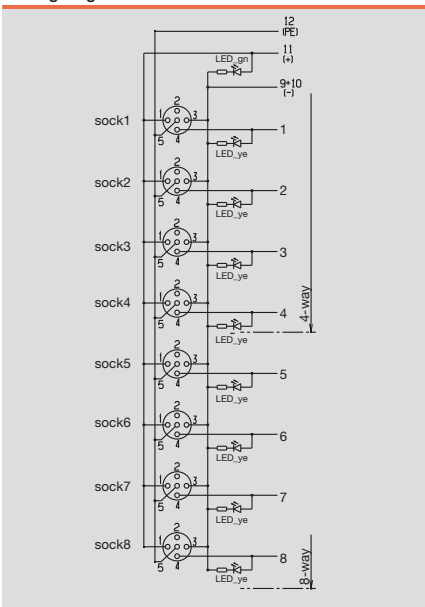

Wiring diagram

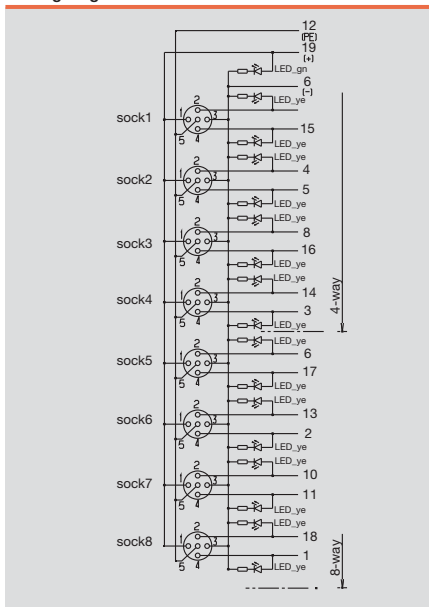

SAI distributor M12 with M23

with M23 outlet on front

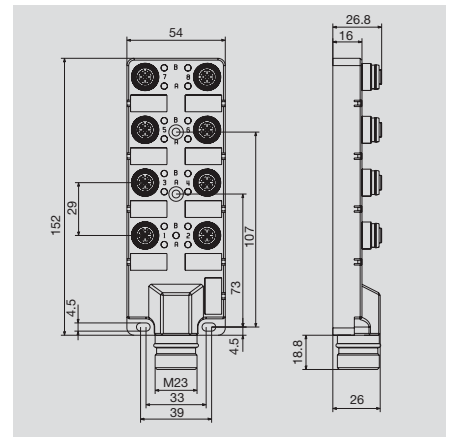

Ordering data

Complete modules	
	4 channel
	8 channel
Note	

SAI-4/8-SH

4-pole

Type	Qty.	Order No.
SAI-4-SH 4P FC	1	1859110000
SAI-8-SH 4P FC	1	1859120000

SAI-4/8-SH

5-pole

Type	Qty.	Order No.
SAI-4-SH 5P FC	1	1859130000
SAI-8-SH 5P FC	1	1859140000

Technical data

Operating voltage	10...30 V
Current of continuous busbars	2 A
max. current-carrying capacity per slot	4 A
Total current	9 A
Pollution severity	3
Protection class	IP 67
Ambient temperature range	-25...+80 °C
Housing main material	PA 6 GF
Contact carrier material	PBT UL 94 V0
Base material of contacts	CuZn, pre-nickeled, gold-plated
screw socket	CuZn, nickel-plated
Housing colour	grey, RAL 7032
Flammability class UL 94	V-0
Clamping range of hood-version	
Suitable for dragline cable (fixed cable connection)	

Wiring diagram

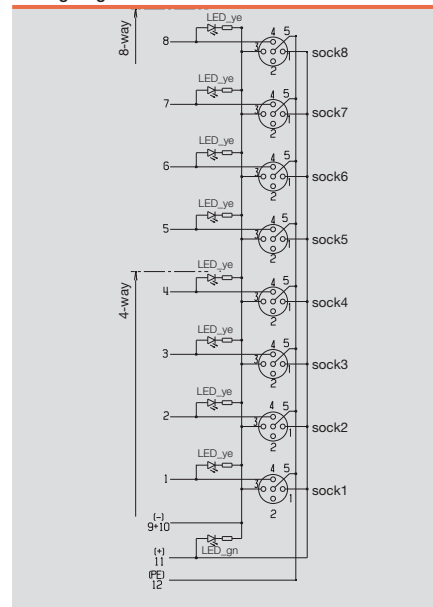

Wiring diagram

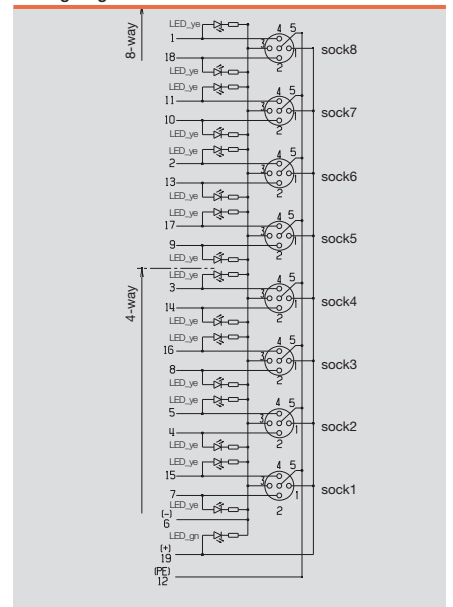

With M23/ M16 outlet

SAI-4/8-M23

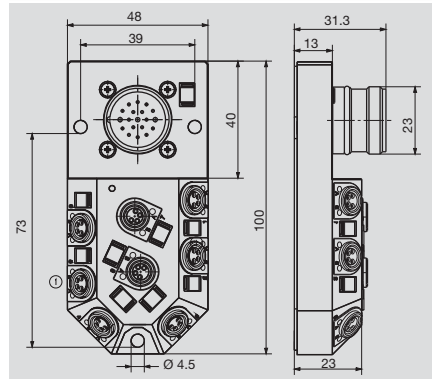

Ordering data

3-pole	8 channel
4-pole	4 channel
	8 channel
Note	

SAI-4/8-M23

M23

Type	Qty.	Order No.
SAI-4-M23 4P M8	1	1784660000
SAI-8-M23 4P M8	1	1784650000
Other versions on request		

Technical data

Operating voltage	10...30 V
Current of continuous busbars	2 A
max. current-carrying capacity per slot	2 A
Total current	8 A
Pollution severity	3
Protection class	IP 68
Ambient temperature range	-20...+90 °C
Housing main material	Pocan
Contact carrier material	PBT UL 94 V0
Base material of contacts	CuZn, pre-nickeled, gold-plated
screw socket	CuZn, nickel-plated
Housing colour	grey, RAL 7032
Flammability class UL 94	V-0
Clamping range of hood-version	
Suitable for dragline cable (fixed cable connection)	

Wiring diagram

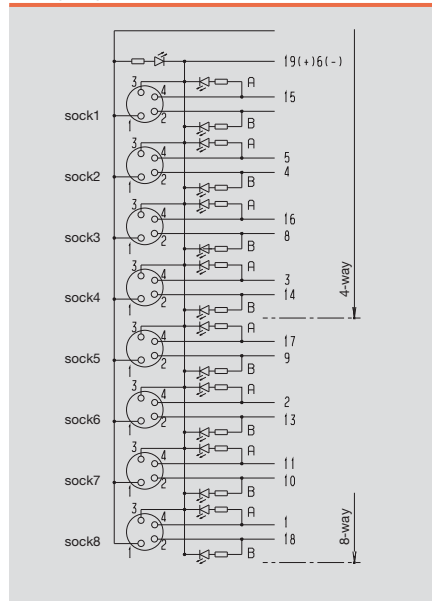

Cable connector

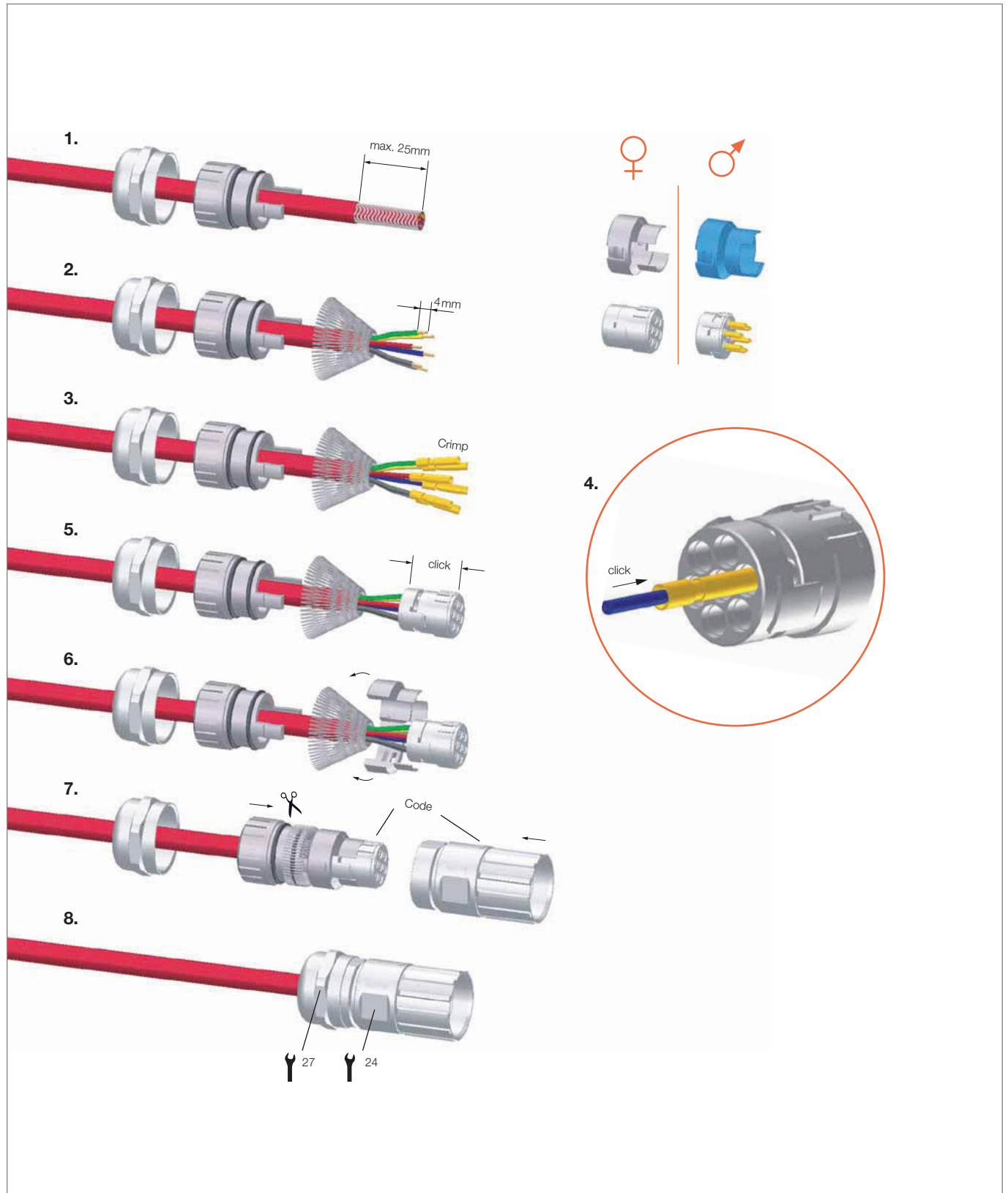

Angled connector

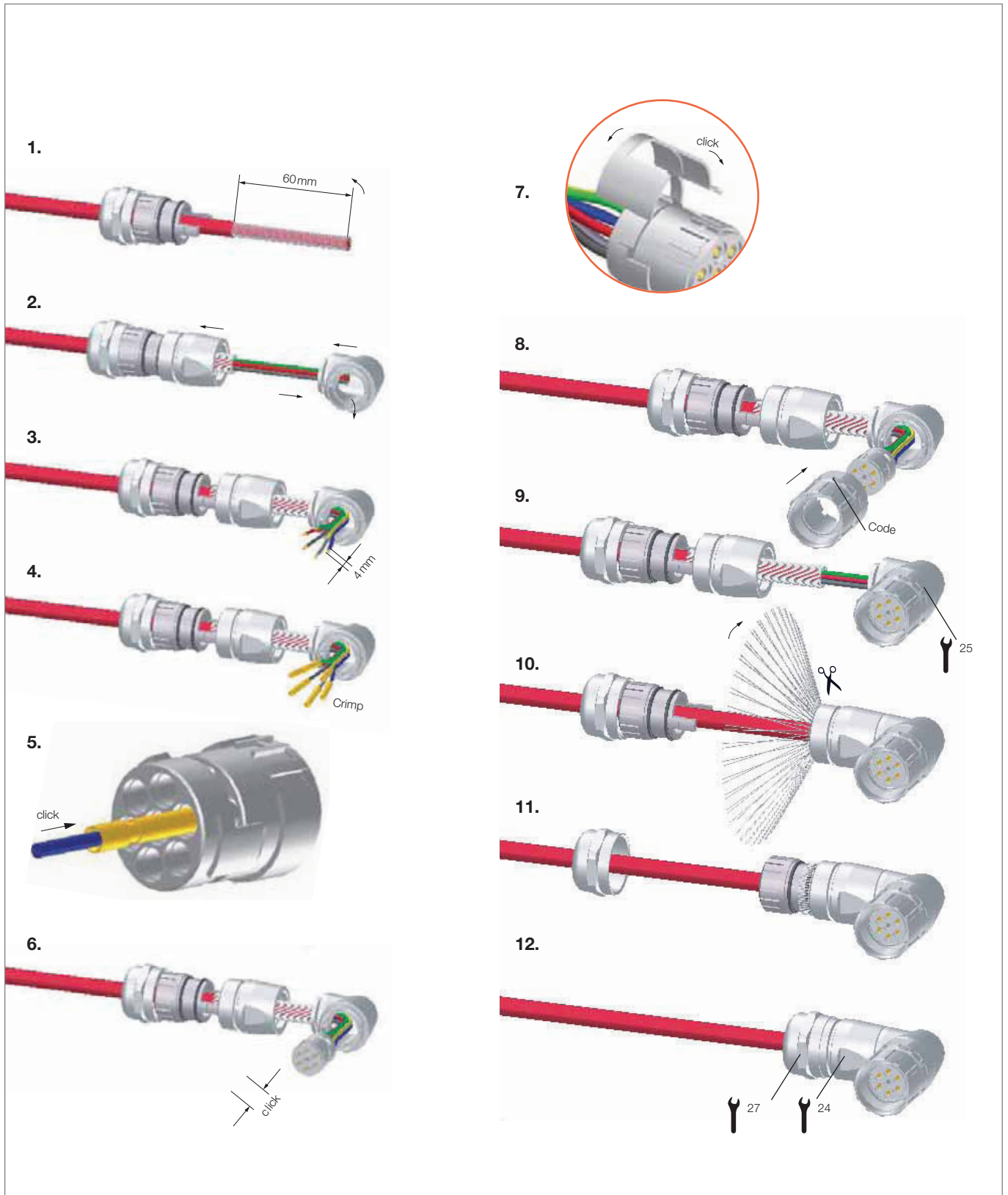

Device connector with knurled nut

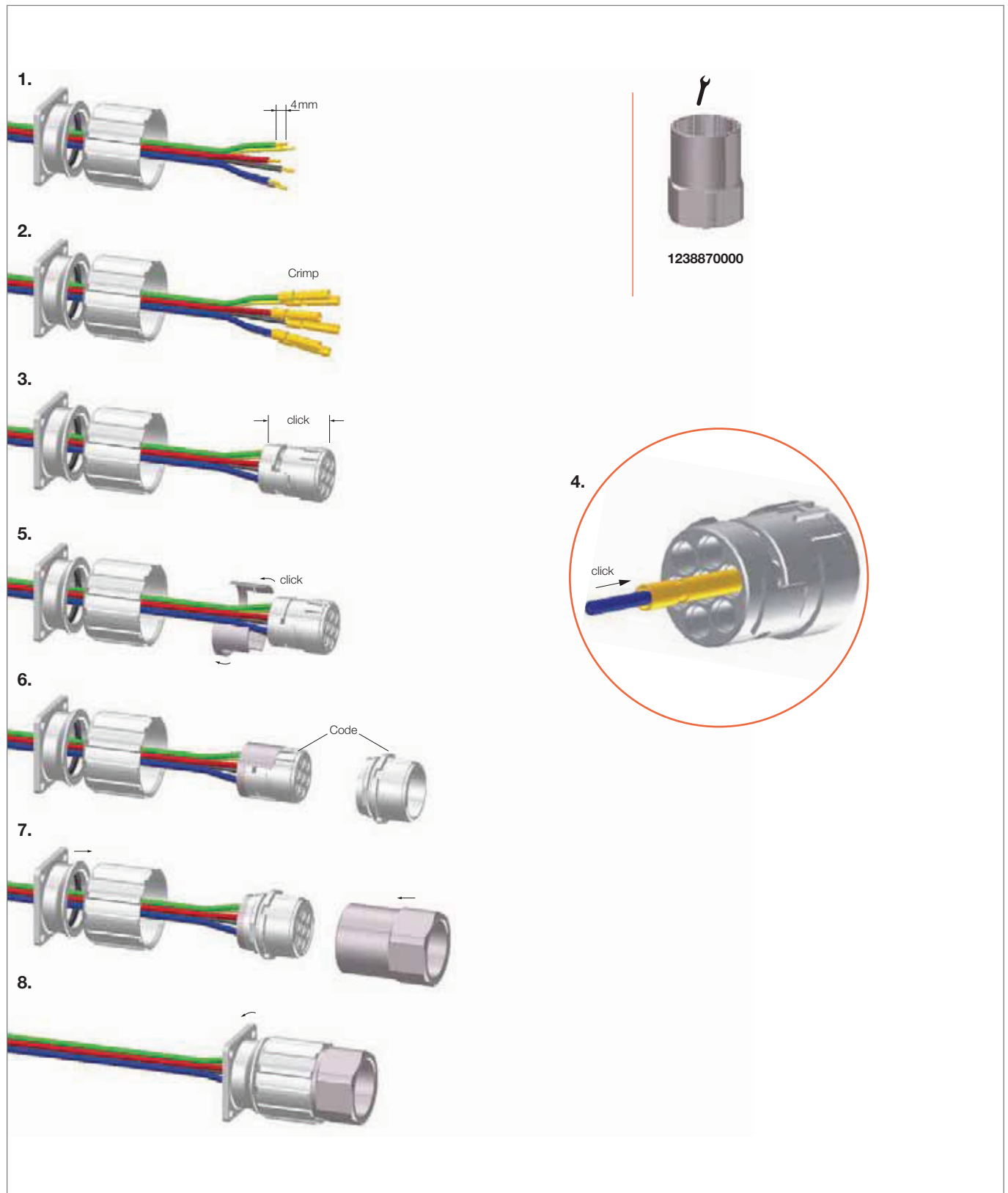

Device connector, male

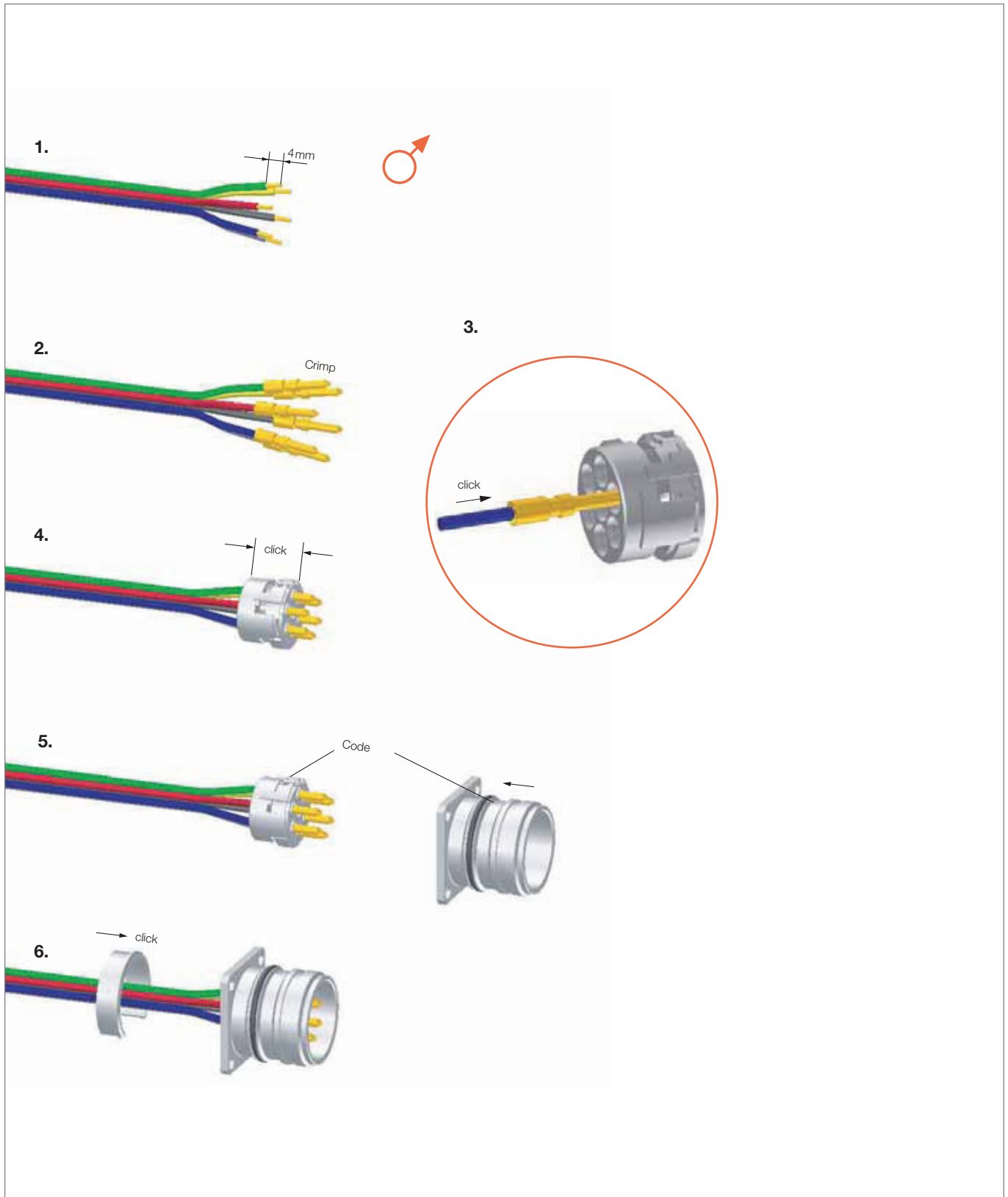

H

Device connector, female

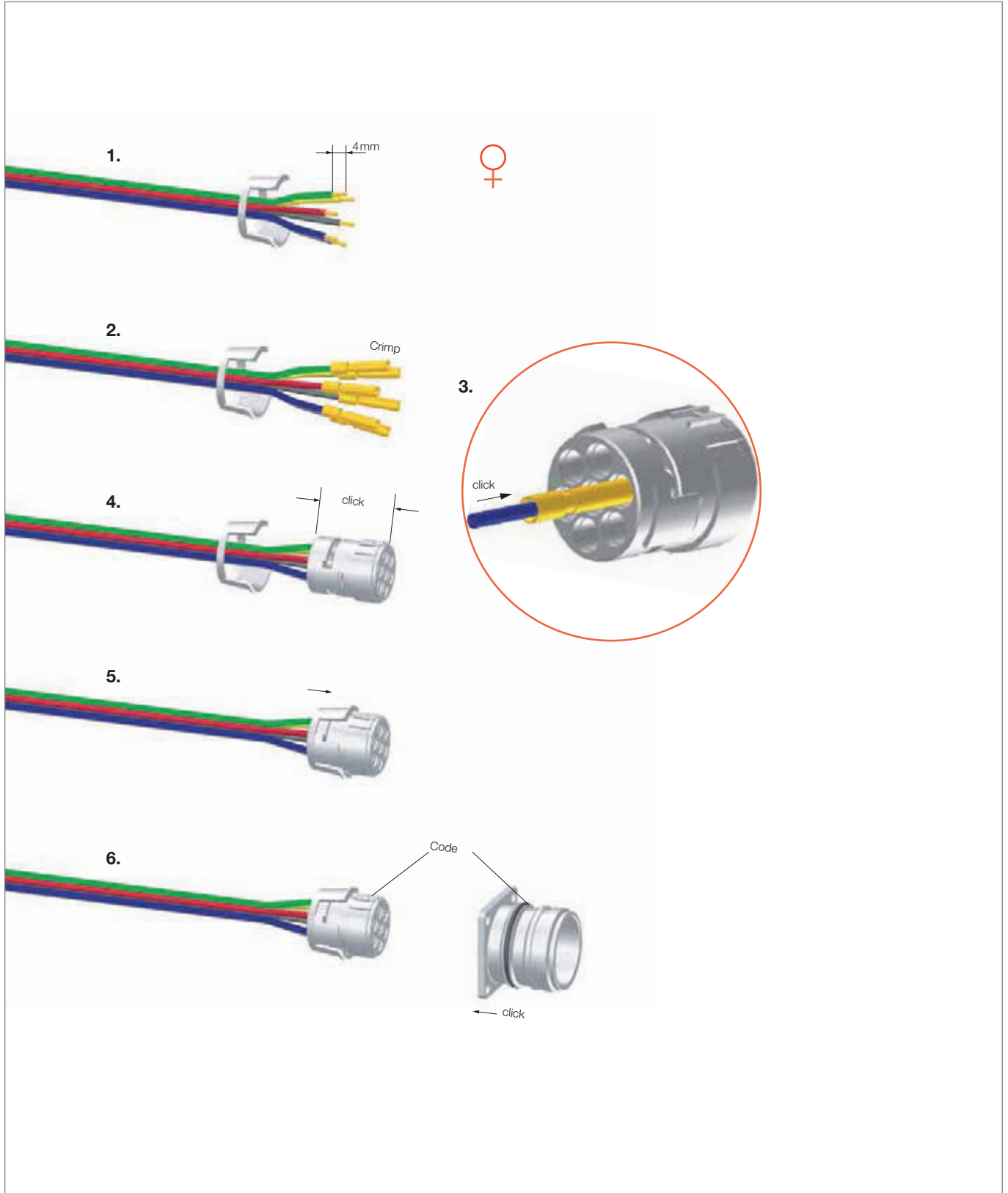

Cable connector

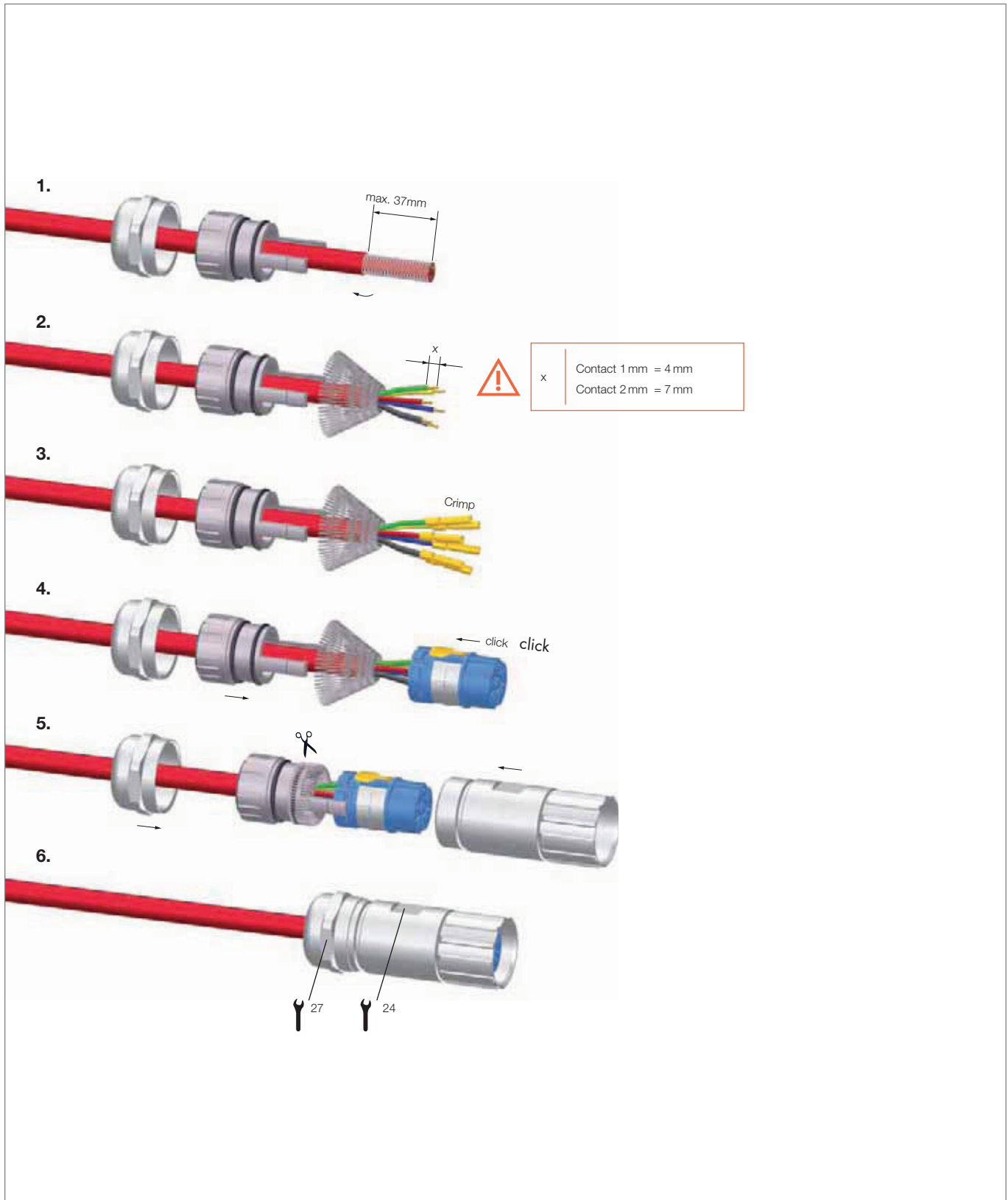

H

Device connector

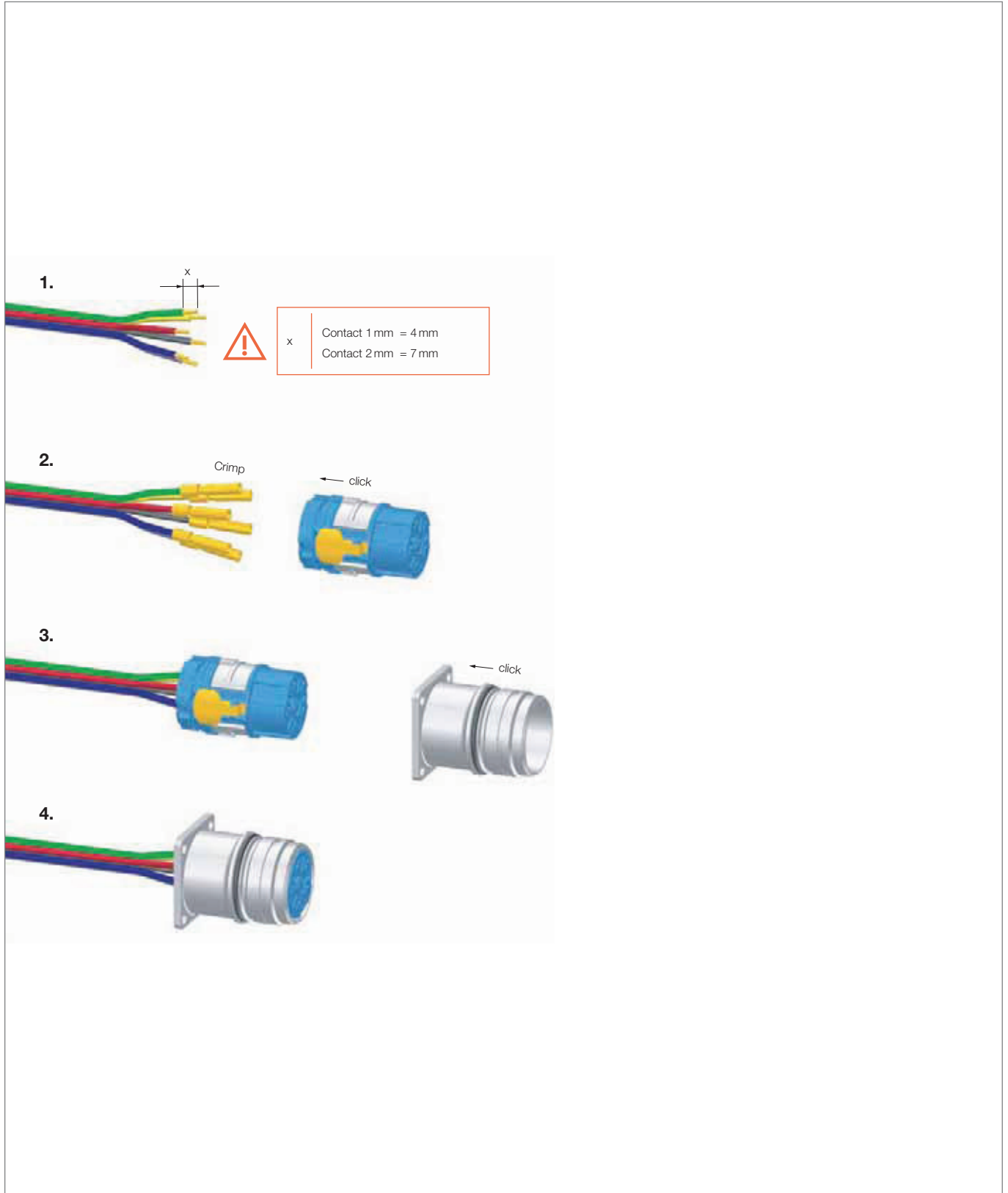

Device connector

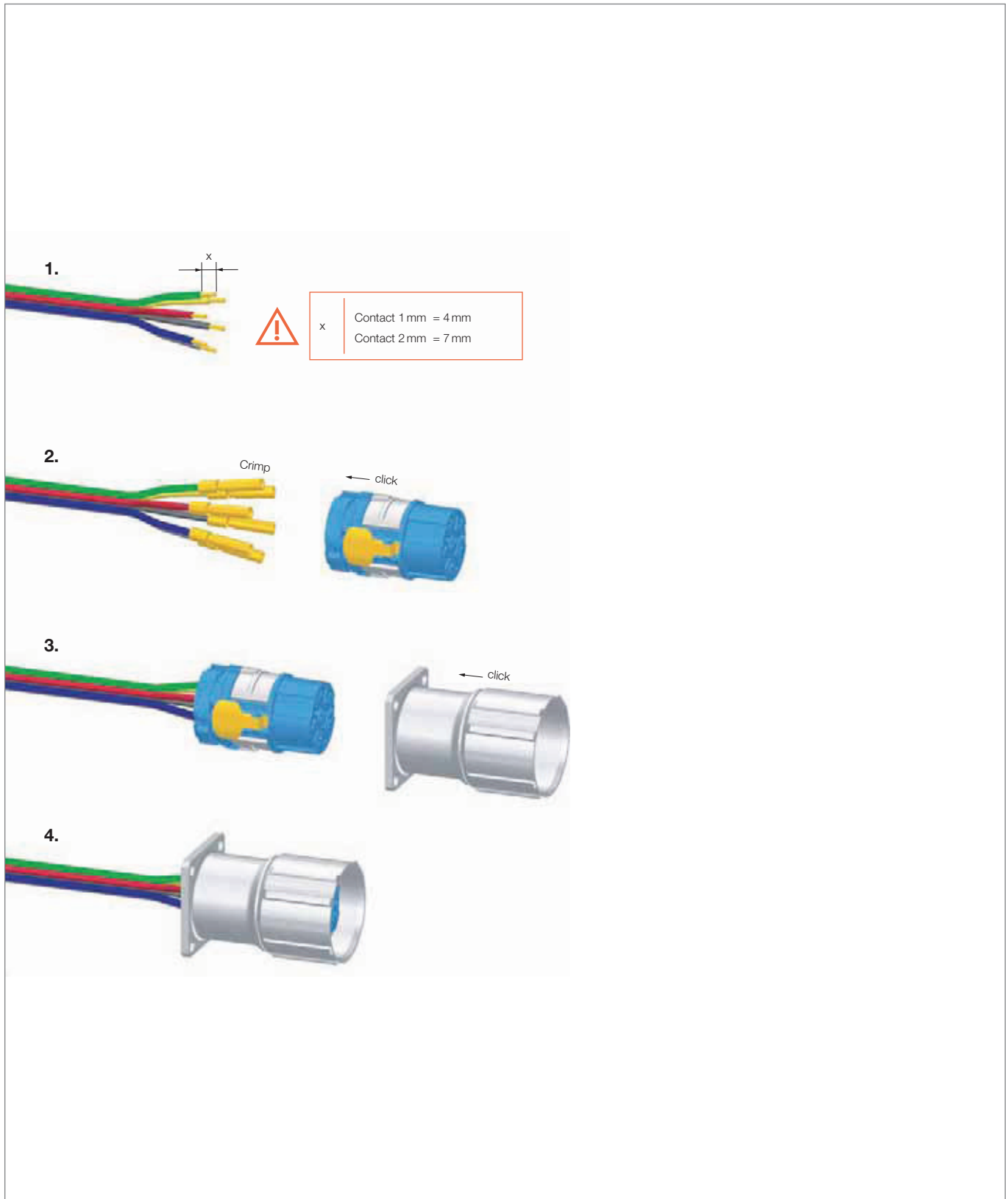

Device connector, single-hole mount

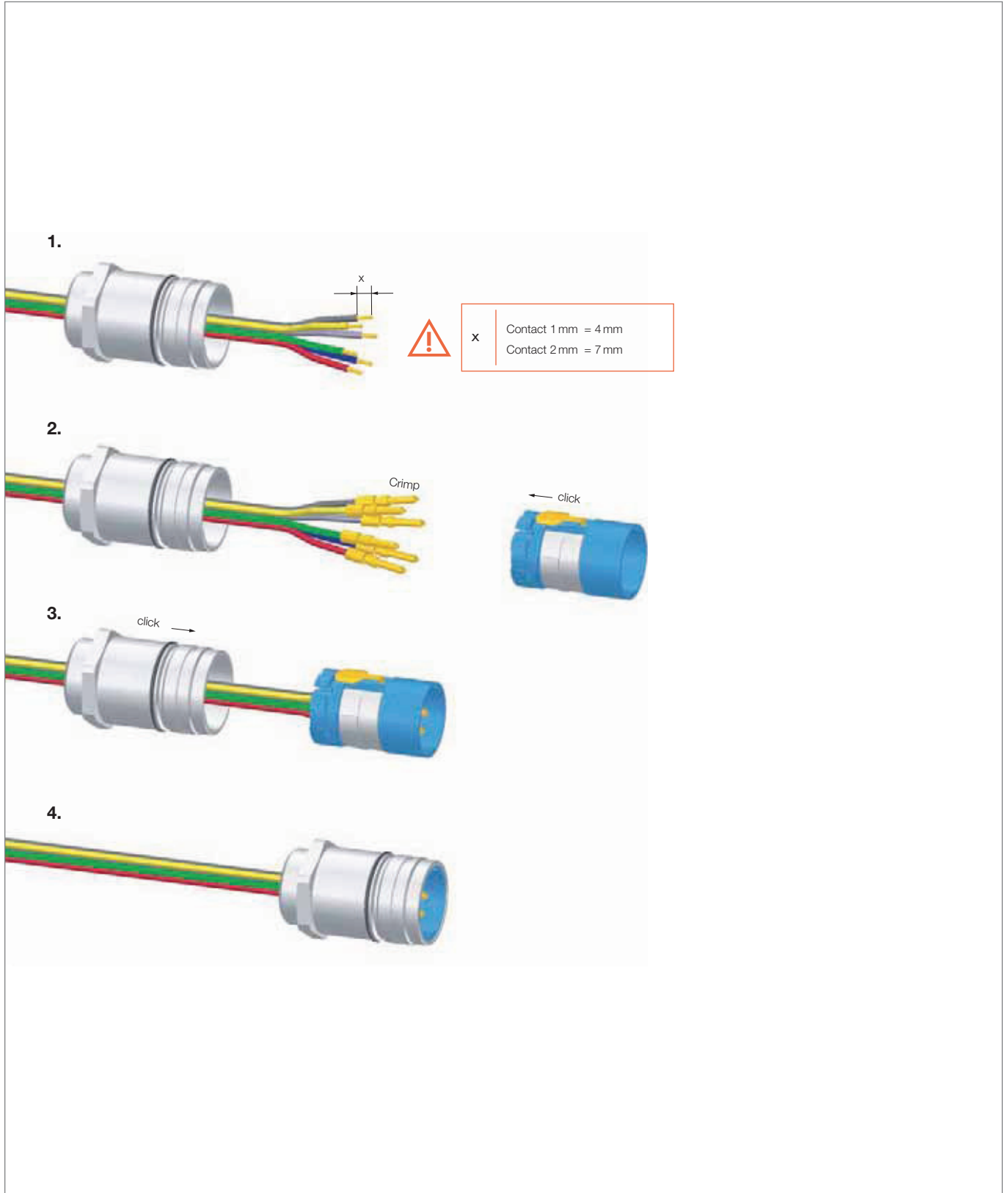

M23 connector

Easy to assemble

- An integrated approach for all plug sizes
- A patented assembly module consisting of terminal insert and insulating body
- Assembly and shield connection combined into one step
- Simple, quick and safe assembly in the housing



Flexibility



Total modularity means flexibility. Male or female inserts can even be used with any of the housing types for the M23 power connectors.



The concise layout of this connector range and the reduced number of individual parts has clear benefits for the user – speedier assembly and easier installation.



The spacer sleeves are colour-coded for the male and female inserts.



Assembly and shield connection are combined into one step.



The snap-on terminal insert protects the cable outlet from getting twisted.



The variable shield connection ensures secure EMC protection for both light and heavy shielding braid.

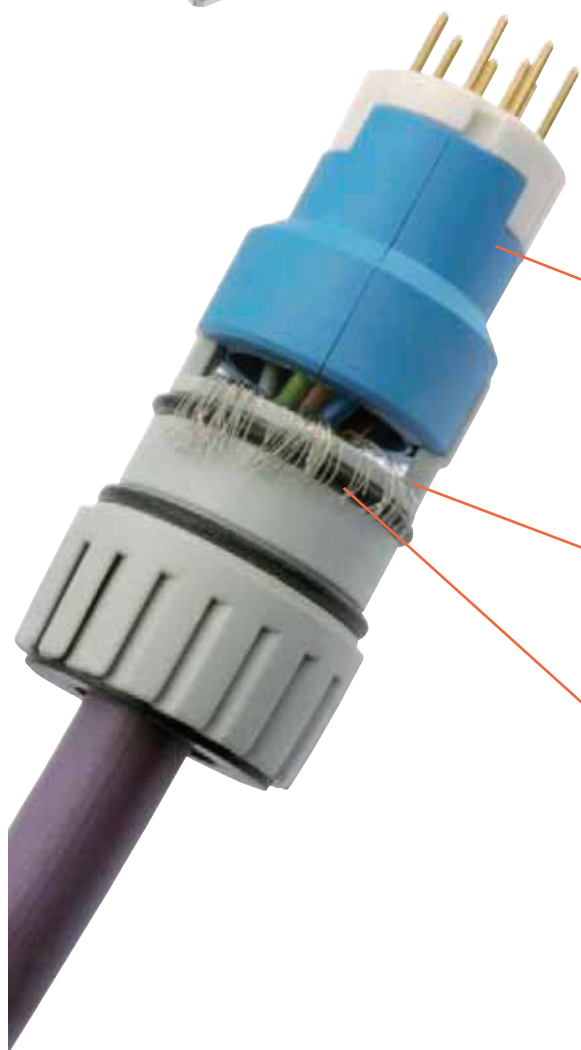

M23 connector

Secure contact with SLS® technology

The new, premium-grade contact – the spring-loaded socket (SLS®) system

- Integrated spring takes the pin contact and clasps it radially
- Outstanding electrical characteristics with the most secure contact
- Quick assembly: solder contacts already tin-plated

H

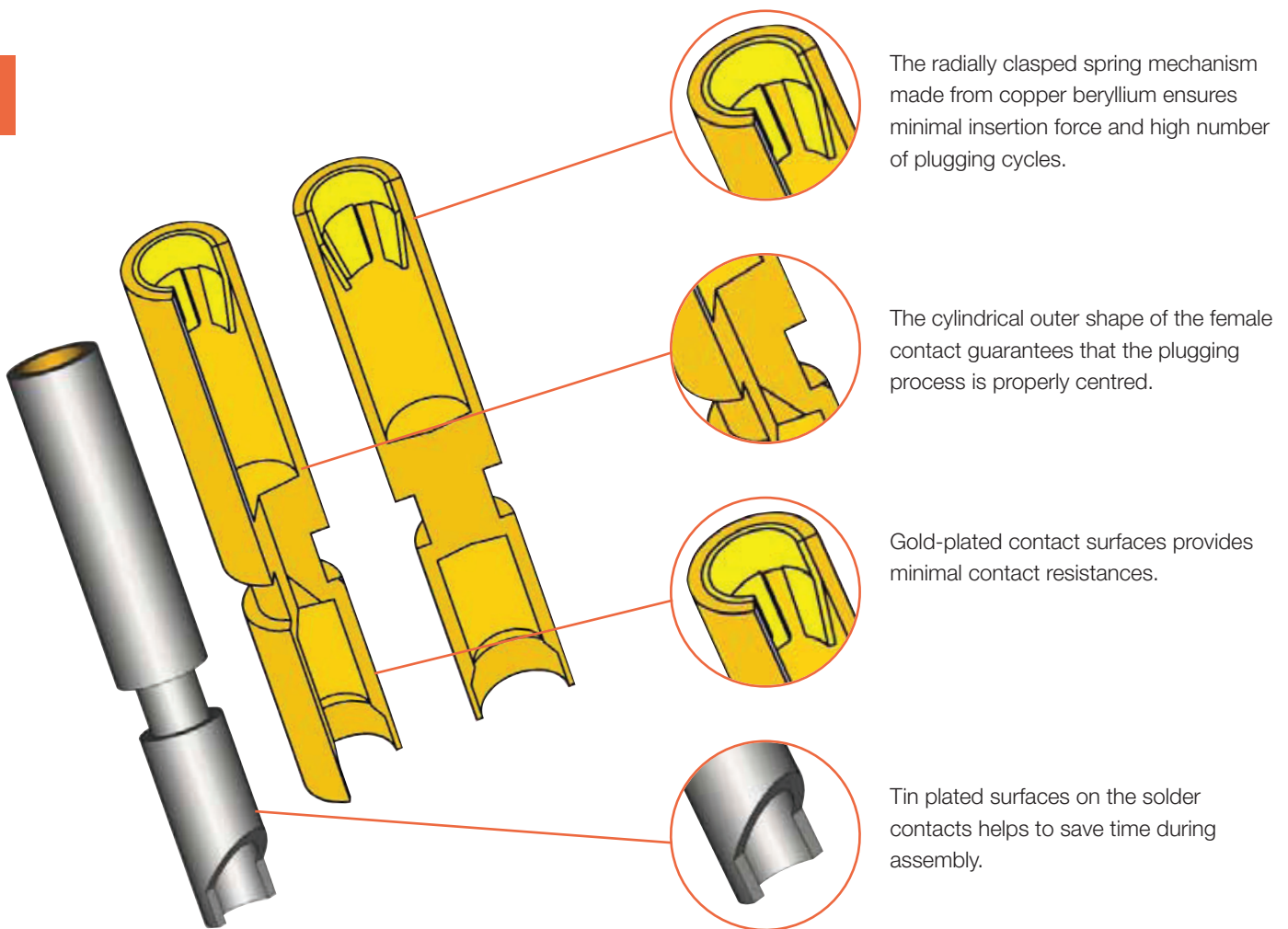

Euro-Lock system® for a secure mount

Euro-Lock system® – the patented interlock system

- The integrated support clip locks the contacts into the insulating body
- Contacts are easy to install and remove
- No special tool is required

High-quality cable gland

- Replaceable male or female inserts in each type of housing
- Integrated strain relief mechanism with patented HSK cable gland
- Internationally certified, with proven and established quality

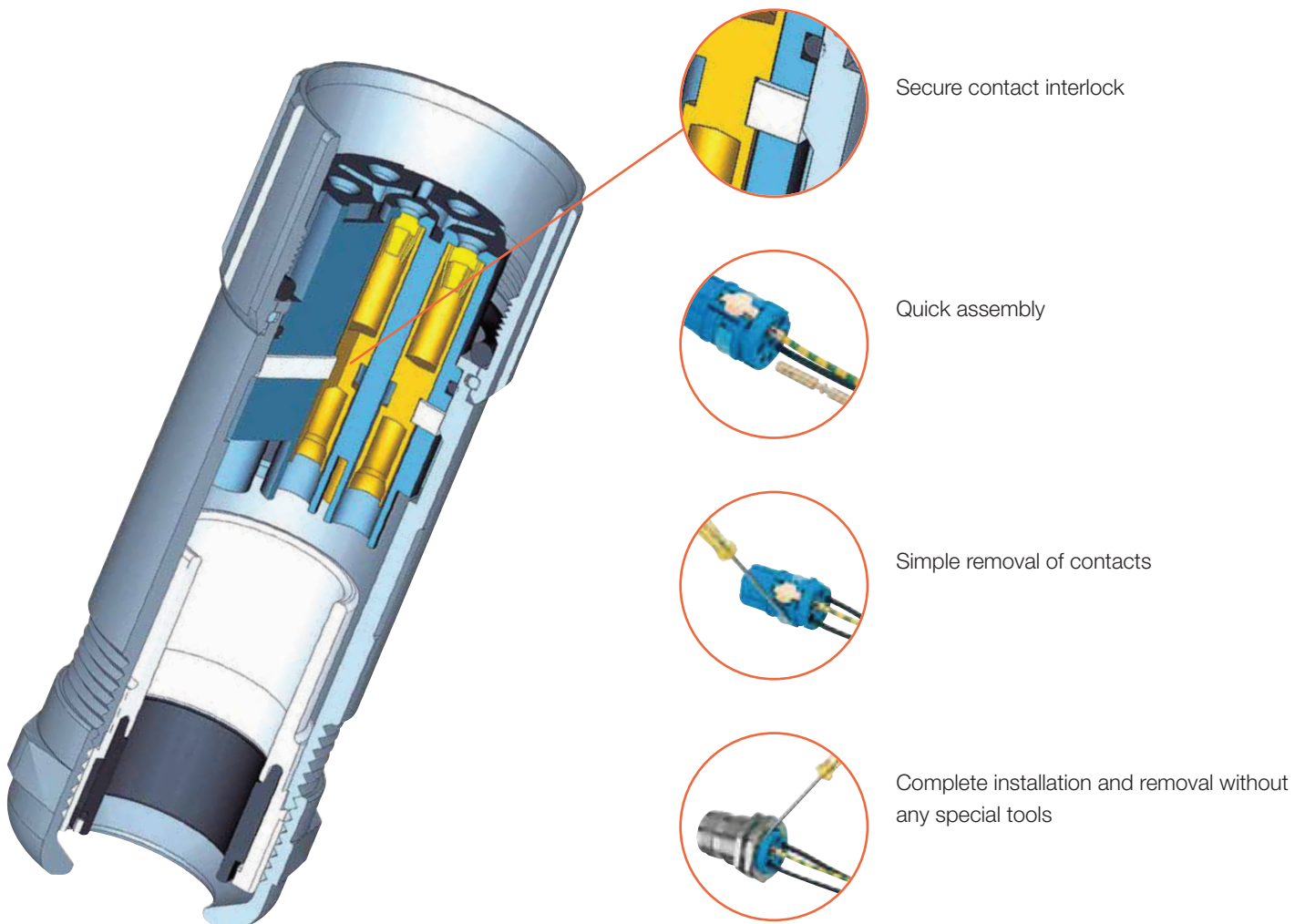

Secure contact interlock

Quick assembly

Simple removal of contacts

Complete installation and removal without any special tools

X-ON Electronics

Largest Supplier of Electrical and Electronic Components

Click to view similar products for [weidmuller](#) manufacturer:

Other Similar products are found below :

[8924550000](#) [56956](#) [0133660000](#) [6720000227](#) [6720005111](#) [68676](#) [69718](#) [EXO24CH](#) [7760056106](#) [7760056348](#) [7940000218](#) [8005181001](#)
[8008180000](#) [8432240000](#) [8463580000](#) [8545830000](#) [8689870000](#) [8705640000](#) [9001080000](#) [9003720000](#) [9004250000](#) [9004780000](#)
[9013260000](#) [9014100000](#) [9019040000](#) [9026010000](#) [9028630000](#) [903708](#) [9037350000](#) [9046290000](#) [9129643500](#) [913155](#) [9159530000](#)
[919656](#) [919764](#) [9202230000](#) [9202850000](#) [9456750000](#) [9457913000](#) [980811](#) [980826](#) [9912800003](#) [9916080000](#) [9916280012](#) [9918380000](#)
[9919371205](#) [9919371224](#) [9925710000](#) [9927480024](#) [1166660000](#)