

Application Note

Multifunctional 2-Channel Amplifier Board

Introduction

In most applications of visible blind uv-detectors such as the **twlux** TW30-series only very small photocurrents are generated. These currents ranging from a microampere down to some picoampere cannot be measured by commonly available multimeters – an amplifier is needed.

We provide a small multifunctional amplifier board for developers to simplify and support application development.

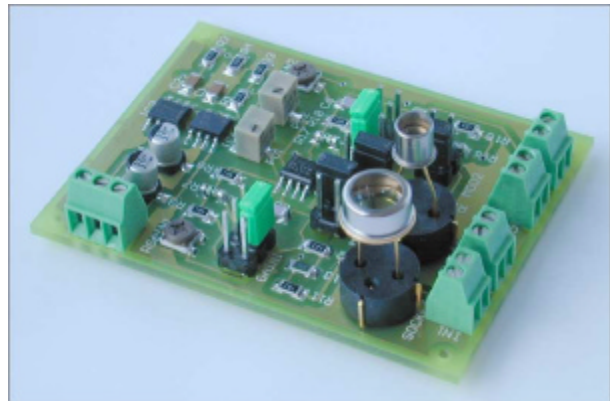

Note: The board is shipped without any photodiodes.

Basics

Photocurrents can be converted to voltages by transimpedance amplifiers (TIA) or switched integrating amplifiers (SIA). Our board utilizes the first type because it does not require digital timing signals. The complete schematic of our board is shown in Appendix B.

For basic knowledge about this device please refer for instance to application notes for device OPA128 from TI at <http://www.ti.com/>. The SIA type is preferably for applications using micro controllers and DSPs – for further information please refer to datasheets and application notes as for instance from <http://www.ti.com/> for device IVC102.

Specifications

The supplied board consists of two independent amplifier channels with adjustable gain. By using jumpers one can select the amplifier type (voltage or transimpedance amplifier) and configuration (two independent amplifiers or single two-stage amplifier) as well as the gain.

The board provides current gain in the range 10^5 V/A... 10^7 V/A and voltage gain from 2...1000 V/V in single-stage configuration. Additionally to the fixed gain factors are potentiometers for custom gain factors in the range 10^4 V/A... 10^6 V/A. By two stages one may reach gains of 10^{10} V/A respectively 10^5 V/V if offsets are carefully adjusted. The maximum usable output voltage range is ± 4 V and must be considered while calculating gain factors.

The circuit is ideally operated with a dual power supply of ± 9 V... ± 24 V. For lower performance measurements a single supply of 24 V...36 V may be used. In both cases stabilisation is not required.

Note: Applying operating voltage with a wrong polarity will destroy the board.

The photodiodes plug directly into sockets or are externally connected via screw terminals. The output voltages are available on screw terminals.

The boards dimensions are 45 mm x 60 mm and the height is about 12 mm without photodiodes.

Application Note

Multifunctional 2-Channel Amplifier Board

Starting

The index “x” in names relates to the channel number, for positions and pin numbers please refer to the picture on the right.

- Choose operation modes and configuration by setting jumpers MODx and STAGES; refer to Appendix A, tables 2 and 3.
- Set required gains with jumpers GAINx and/or potentiometers RGAINx; again refer to Appendix A, table 4.
- Connect arbitrary voltmeter(s) to screw terminals OUTx. Right pin (#1) is the output, left pin (#2) equals to GND.
- Connect the power supply to screw terminal PWR. For dual power supply use top terminal (#3) for negative, middle (#2) for GND and bottom terminal (#1) for positive voltage. A single supply must be connected with positive pole to bottom pin (#1) and supply GND to top pin (#3), middle pin is left open. **Note:** In case of single supply there is a floating virtual ground on the middle terminal to which the inputs and outputs relate and which must not be connected to power supply GND.

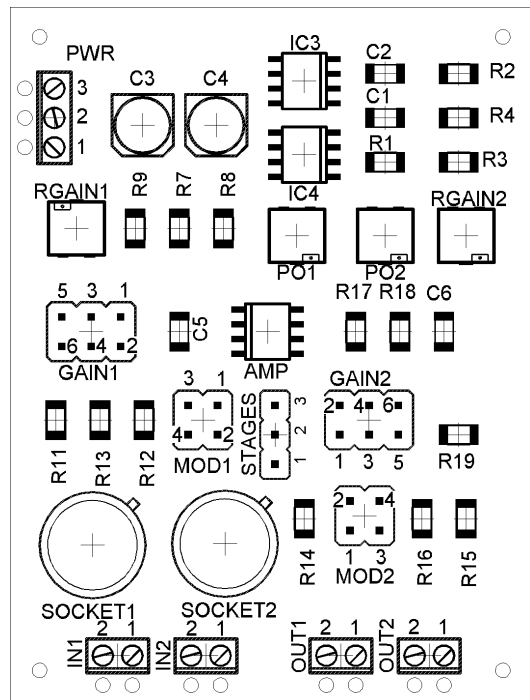

- Adjust offsets for all channels. To do this shorten inputs for voltage amplifiers and leave inputs open (or insert photodiodes and darken them to compensate dark currents as well) for transimpedance stages. Now adjust the output voltages to 1mV or less by potentiometers POx.
- Connect photodiode(s) to either terminal INx or SOCKETx. The right pins (#1) of screw terminals INx are the inputs, the left pins (#2) equal to GND. If using the sockets the upper pinhole is the input and must be plugged with one photodiode pin in any case. Other pinholes are grounded and may be used as required. Polarity of the photodiodes within sockets depends only on desired output voltage polarity.

Application Note

Multifunctional 2-Channel Amplifier Board

Examples

Problem:

- Compare photocurrents of two different photodiodes of types TW30SX and TW30DZ to show effect of higher visible blindness. This task requires two identical channels. The predicted photocurrents under sun radiation are $2.2 \mu\text{A}$ / $1.6 \mu\text{A}$. The output voltage shall be 1...2 V giving a suitable gain of $1 \text{ V}/\mu\text{A} = 10^6 \text{ V/A}$.

Solution:

- ✓ set jumper STAGES to position 1-2 (two channel mode), set MOD1 and MOD2 to position 1-2 (transimpedance amplifier)
- ✓ set GAIN1 and GAIN2 to position 2-4 (transimpedance gain 10^6 V/A)
- ✓ connect and turn on power supply
- ✓ insert photodiodes, darken them, compensate offsets (and dark currents) by adjusting PO1 and PO2
- ✓ illuminate photodiodes with visible and ultraviolet light, compare voltages on terminals OUT1 and OUT2

Problem:

- Convert a photocurrent of 1 nA to a voltage of 2.0 Volts. This requires a total gain of $2 \text{ V/nA} = 2 \cdot 10^9 \text{ V/A}$, which can be provided by two amplifier stages. The first stage converts the current to a voltage of 10mV with a gain 10^7 V/A , which is then boosted to 0.2 V by the second voltage amplifier stage with a gain of 20 V/V. This voltage can be displayed easily by a standard digital panel voltmeter.
- Hint: You can replace the gain jumpers of stage 1 by a multi stage switch to obtain fast and easy range adjustment. The second contact layer of this switch may be used for decimal point shifting on the panel voltmeter.

Solution:

- ✓ set jumper STAGES to position 2-3 (two channel mode)
- ✓ set MOD1 to position 1-2 (transimpedance amplifier) and GAIN1 to position 1-3 giving 10^7 V/A in the first stage
- ✓ open MOD2 (voltage amplifier, pre-gain 2) and set GAIN2 to position 1-3 (giving overall voltage amplification of 200 in stage two)
- ✓ connect and turn on power supply
- ✓ insert photodiode into SOCKET1 and darken it; first compensate offset of first stage by adjusting PO1 until voltage on OUT1 is below 1 mV; then compensate offset of second stage by adjusting PO2 until voltage on OUT2 is below 1 mV
- ✓ illuminate photodiode and measure voltage on terminal OUT1

Application Note

Multifunctional 2-Channel Amplifier Board

Appendix A

Table 1: pin, terminal and other assignments

	Pin 1	Pin 2	Pin 3
PWR	+8 V ... +24 V	GND	-8 V ... -24 V
IN1	input terminal channel 1	GND	
SOCKET1	input socket channel 1	GND	GND
OUT1	output terminal channel 1	GND	
PO1	offset compensation channel 1		
IN2	input terminal channel 2	GND	
SOCKET2	input socket channel 2	GND	GND
OUT2	output terminal channel 2	GND	
PO2	offset compensation channel 2		

Table 2: channel configuration

STAGES	Function
1-2	two independent amplifier channels
2-3	single two-stage amplifier; note: channel two must be configured as voltage amplifier by setting MOD2 in any position but 1-2

Table 3: amplifier mode

MODx	Function
1-2	transimpedance amplifier
1-3	voltage amplifier pre-gain 10
3-4	voltage amplifier pre-gain 5
Open	voltage amplifier pre-gain 2

Table 4: gain factor setting

GAINx	transimpedance gain [V/A]	voltage gain (multiply by voltage pre-gain to get total voltage gain) [V/V]
1-3	10^7	100
2-4	10^6	10
3-5	10^5	1
4-6	adjustable by potentiometer RGAINx in range $10^4 \dots 10^6$	0.1...10

Application Note

Multifunctional 2-Channel Amplifier Board

Appendix B

Schematic:

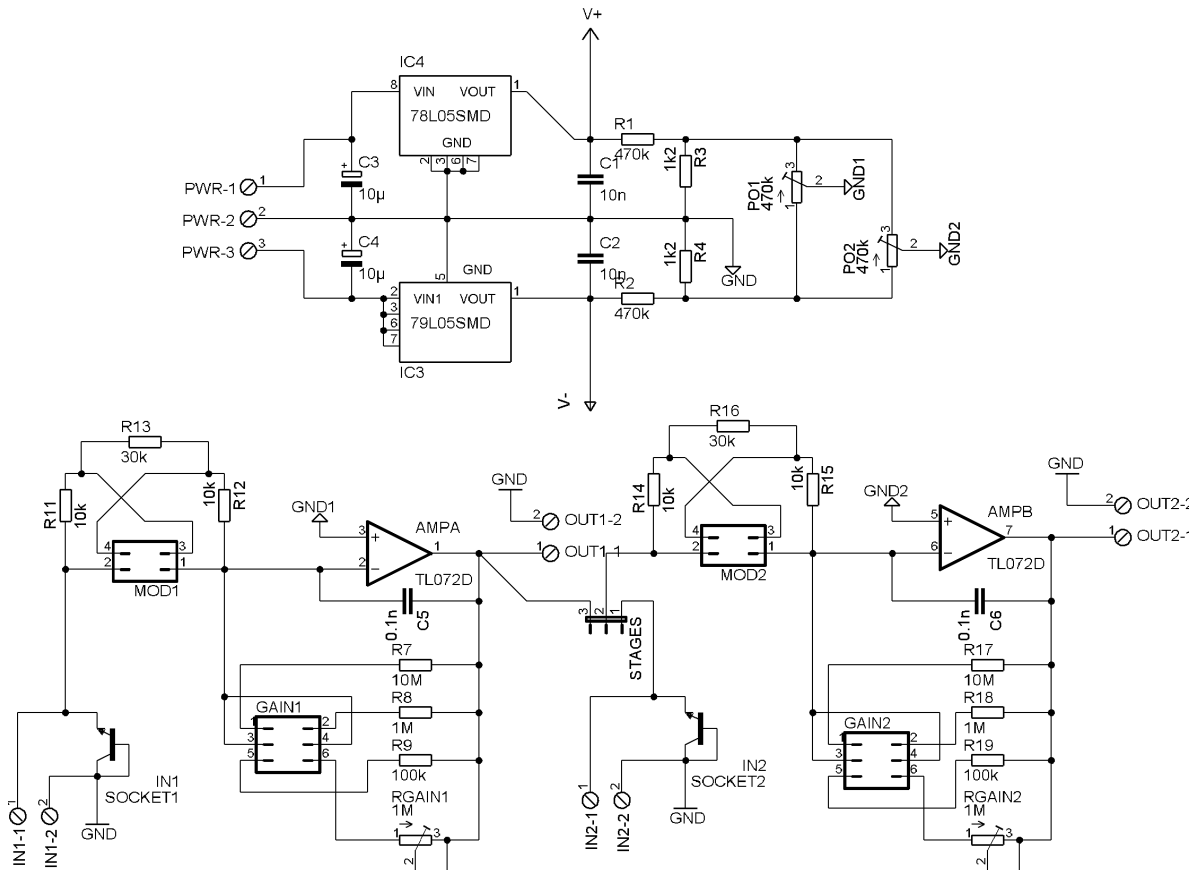

X-ON Electronics

Largest Supplier of Electrical and Electronic Components

Click to view similar products for [sglux](#) manufacturer:

Other Similar products are found below :

[SG01L-18](#)