

Staying tough at the top



When it comes to professional connecting devices with machined precision contacts (read: IC-sockets, PCB connectors and allied products) you can consider Preci-Dip as one of the top addresses in the world.

Preci-Dip's skill and manufacturing experience, combined with a strongly dedicated sales organisation, offer you total security, all over the world. Security in terms of quality. Of timely deliveries. And last but not least: of price.

Play it safe and call the top address for your needs of Sockets and Strips, of Carriers, PGAs and PCB Connectors and of customized products – for YOUR security and peace of mind.

PRECI-DIP

DURTAL

Thanks to the highly automated precision machining division at the Preci-Dip production plant, most Preci-Dip products come with high quality machined contacts for additional safety and durability.

Machined precision contacts

Preci-Dip's contact technology for receptacles uses three, four or six finger clips made of CuBe and housed in a machined brass sleeve. Platings can be different for both parts, e.g. tin for the sleeve, gold for the clip.

Contact clips are produced on modern, high speed precision stamping machines and inserted – after plating of both parts – into the sleeve on fully automatic assembly lines. Receptacles made by Preci-Dip are of extremely good reliability and have excellent performances with respect to shock and vibration, number of matings, contact resistance, etc...

One of the most important features, however, is the closed design of the sleeve which makes it absolutely safe against flux wicking during the soldering process.



Insertion diameter and contact point

Insertion diameter and contact point of the receptacles may vary depending on contact type.

These relevant values are normally indicated on each catalog drawing representing a receptacle:

- insertable pin diameter (0.40–0.56 mm) or rectangle (0.25 × 0.45 mm) is shown on top of part
- distance between contact point and upper edge of receptacle (2.4 mm) is shown on left side of part.

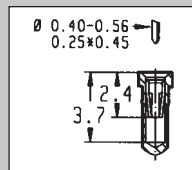

Male contacts

Male contacts have cylindrical, machined pins. In comparison to pins with square or rectangular section, this provides for smoother insertion/extraction with more constant forces, longer life and higher reliability.

The terminations of machined contacts are rugged and accurately positioned; bending of leads by inadvertance is almost excluded which makes handling very easy.

Interconnect components

Machined pins are ideally suited for all kinds of board-to-board interconnecting applications. Their ruggedness and precision are major advantages when reliability and sturdiness of the mechanical assembly are major requirements.

Interconnect contacts are available in a variety of different lengths to suit a maximum number of applications.

They are mostly fitted to single or double row strip insulators but they are also available on dual-in-line or other body styles.

The fact of these contacts being machined allows to manufacture customer specific lengths with no or very little tooling cost.

Insulator bodies

Precision injection molded insulator bodies are made of temperature resistant thermoplastic material, to withstand soldering heat and climatic requirements. All the plastic materials used on Preci-Dip products are UL 94-V0 rated.



Contact strips have a notched design. The insulators are thus easy to cut to any length – in most cases without any loss of contact.

Carriers

Disposable insulators made of recycled plastic material with carrier pins and plugged-on contacts are used on Preci-Dip's unique carrier sockets and strips.

These carriers are rugged and have the same rigidity and precision as the standard sockets and strips. In comparison to flexible carrier solution, Preci-Dip carriers are as easy to handle as normal precision sockets and strips.

All styles of insulator bodies including PGAs can be equipped for carrier applications.

Products with stamped contacts

Some Preci-Dip product lines come with stamped contact versions. Please refer to respective product pages for detailed information.

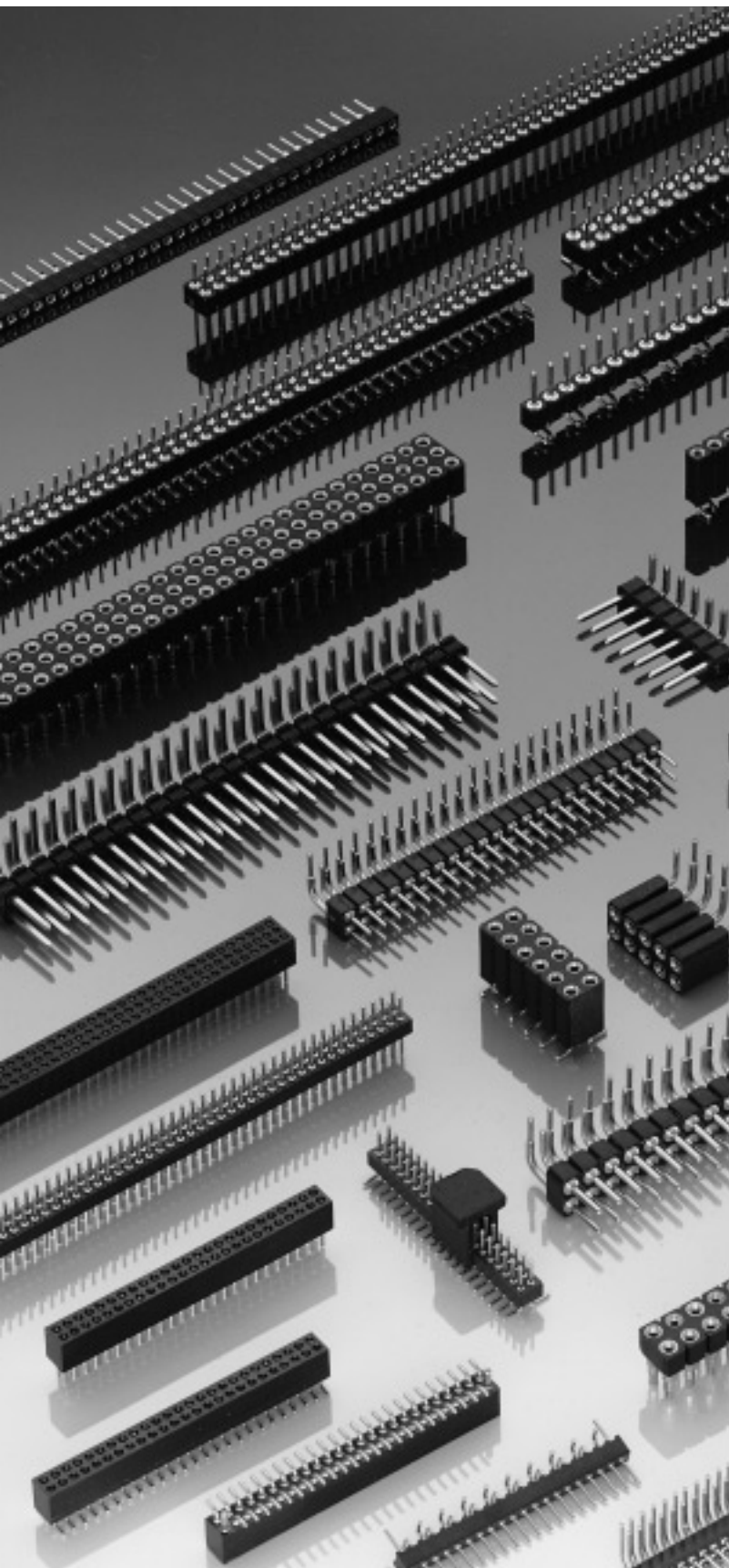

Technical specifications

Materials

- Insulator: Glass filled thermoplastic polyester, self extinguishing UL 94 V-0, colour black, resistant to mineral acids, solvents, greases, oils (short time).
- Receptacle contact:
 - Sleeve: Screw-machined brass (QQ-B-626), gold or tin-lead plated (90/10) over 2–3 µm nickel
 - Clip: Stamped beryllium-copper (QQ-C-533), gold or tin-lead (90/10) plated over 2–3 µm nickel
- Pin contact: Screw-machined brass (QQ-B-626) or phosphor bronze (QQ-B-750), gold or tin-lead plated (90/10) over 2–3 µm nickel

	Series			
	850	830	800	300/400/700

Mechanical data

- | | | | | |
|------------------------------|-----------------|------|----------------|------|
| - Insertion characteristics* | | | | |
| - Gauge diameter (mm): | 0.43 | 0.46 | 0.76
(1 mm) | 0.46 |
| - Insertion force (N): | 1.2 | 1 | 1.2 | 1.8 |
| - Withdrawal force (N): | 0.6 | 0.5 | 0.6 | 1 |
| - Mechanical life: | min. 500 cycles | | | |
- * (measured with a polished steel gauge, typical values)

Electrical data

- | | | | | |
|------------------------------------|--|-----|----------|-----|
| - Rated current (A): | 1 | 3 | 3 | 1 |
| - Rated voltage: | 100 V _{RMS} / 150 V _{DC} | | | |
| - Max contact resistance (mΩ): | 20 | 10 | 10 | 10 |
| - Insulation resistance: | 10 000 MΩ min. | | | |
| - Dielectric strength: | 1000 V _{RMS} min. | | | |
| - Air and creepage distances (mm): | 0.4/0.5 | 0.5 | 0.85/0.7 | 0.7 |
| - Capacitance (pF): | 1 | 1 | 1 | 0.8 |

Environmental data

- | | |
|---|------------------------------------|
| - Operating temperature: | -55/+125 °C |
| - Vibration (10–2000 Hz, 15 g): | no electrical discontinuity > 1 µs |
| - Shock: (50 g): | no electrical discontinuity > 1 µs |
| - Solderability (IEC 68-2-54 Ta): | 235 °C, 5 s |
| - Resistance to soldering heat: (IEC 68-2-20 Tb): | 260 °C, 5 s |
| - Resistance to atmospheric corrosion: | IEC 68-2-42 and 43 |
| - Climatic category (IEC): | 55/125/21 |

PRECI-DIP

DURTAL

Series 850

PCB connectors 1.27 mm

Single row / double row / triple row

Solder tail

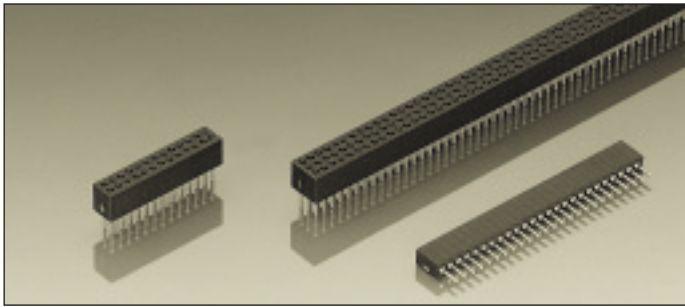

Ultraminiature PCB receptacles, solder tail

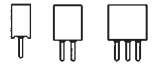



Grid spacing 1.27×1.27 mm

Receptacle for pins

Ø 0.35–0.45 mm

For corresponding pin connectors see pages 13, 14 and 15

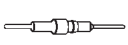
Platings	Sleeve 	Clip 	Pin 
91	5 µm Sn Pb	0.25 µm Au	
93	5 µm Sn Pb	0.75 µm Au	
99	5 µm Sn Pb	5 µm Sn Pb	

Ordering information

Replace **xxx** with the number of poles, e.g. 853-91-**xxx**-10-001 for a double row version with 8 pins per row becomes:
853-91-**016**-10-001

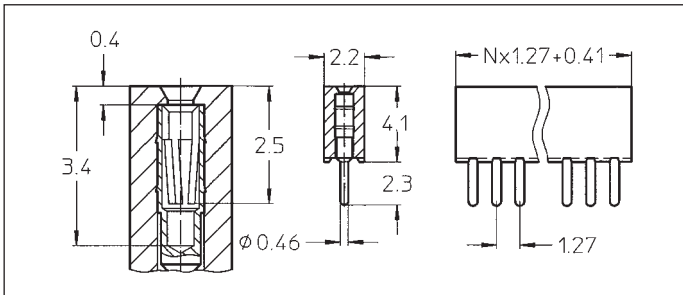

- 851-91-xxx-10-001
- 851-93-xxx-10-001
- 851-99-xxx-10-001

Straight receptacle: solder tail, single row

Availability from: 1 to 50 contacts
Standard number of contacts 25 and 50

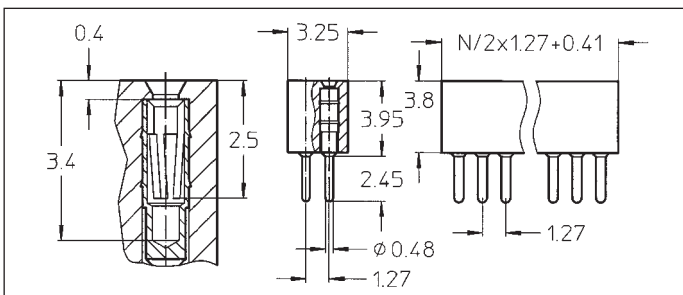

- 853-91-xxx-10-001
- 853-93-xxx-10-001
- 853-99-xxx-10-001

Straight receptacle: solder tail, double row

Availability from: 4 to 100 contacts
Standard number of contacts 50 and 100

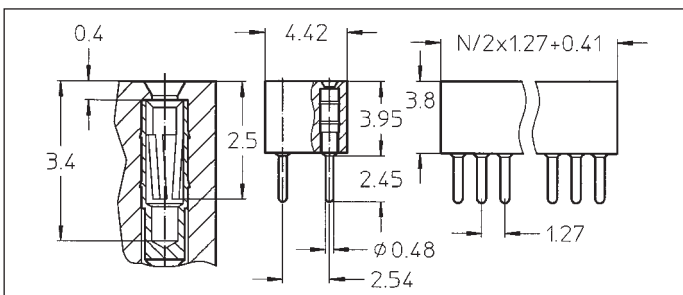

- 853-91-xxx-10-002
- 853-93-xxx-10-002
- 853-99-xxx-10-002

Straight receptacle: solder tail, double row with 2.54 mm row to row distance

Availability from: 4 to 100 contacts
Standard number of contacts 100

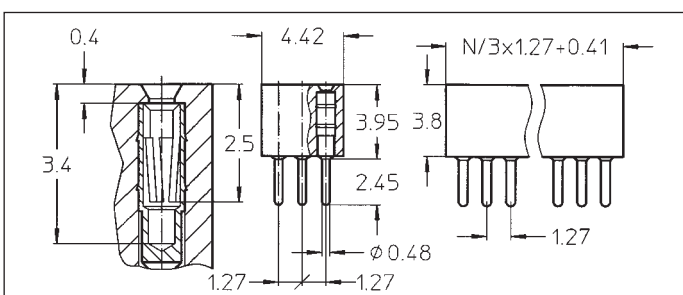

- 855-91-xxx-10-001
- 855-93-xxx-10-001
- 855-99-xxx-10-001

Straight receptacle: solder tail, triple row

Availability from: 9 to 150 contacts
Standard number of contacts 150

Series 850

PCB connectors 1.27 mm

Single row / double row / triple row

Solder tail

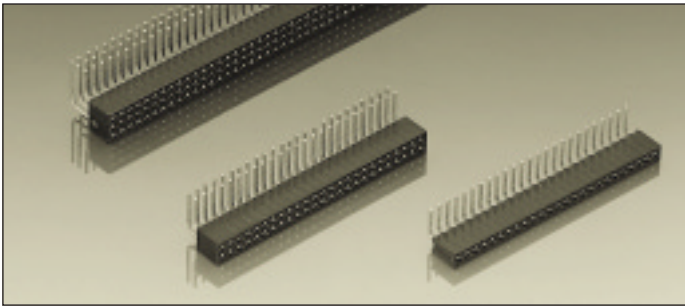

Ultraminiature PCB receptacles, solder tail

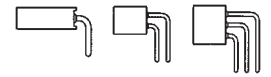



Grid spacing 1.27×1.27 mm

Receptacle for pins

Ø 0.35–0.45 mm

For corresponding pin connectors see pages 13, 14 and 15

Platings	Sleeve 	Clip 	Pin 
91	5 µm Sn Pb	0.25 µm Au	
93	5 µm Sn Pb	0.75 µm Au	
99	5 µm Sn Pb	5 µm Sn Pb	

Ordering information

Replace **xxx** with the number of poles, e.g. 853-91-**xxx**-20-001 for a double row version with 8 pins per row becomes:

853-91-**016**-20-001

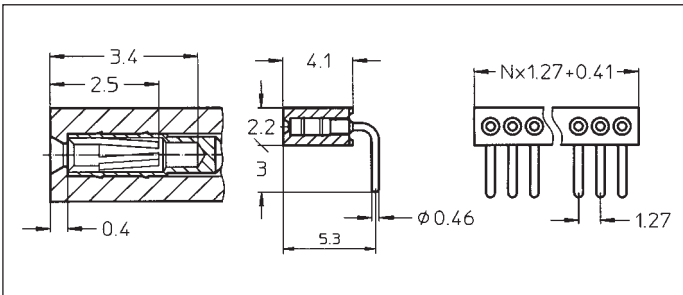

851-91-xxx-20-001
851-93-xxx-20-001
851-99-xxx-20-001

Right angle receptacle: solder tail, single row

Availability from: 1 to 50 contacts
Standard number of contacts 25 and 50

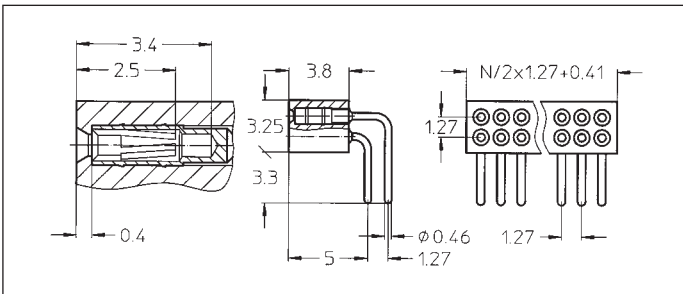

853-91-xxx-20-001
853-93-xxx-20-001
853-99-xxx-20-001

Right angle receptacle: solder tail, double row

Availability from: 4 to 100 contacts
Standard number of contacts 50 and 100

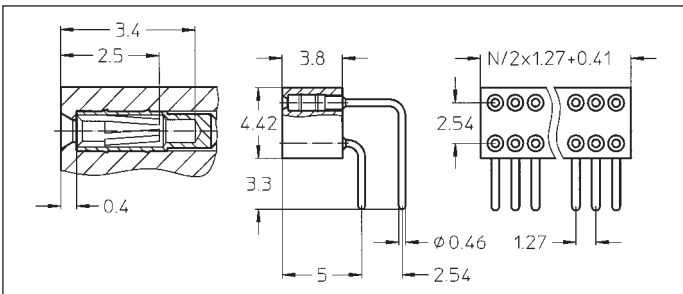

853-91-xxx-20-002
853-93-xxx-20-002
853-99-xxx-20-002

Right angle receptacle: solder tail, double row with 2.54 mm row to row distance

Availability from: 4 to 100 contacts
Standard number of contacts 100

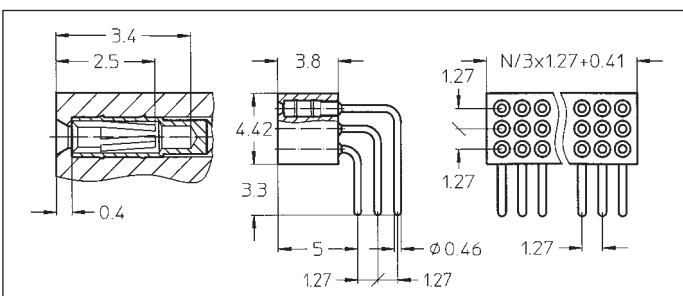

855-91-xxx-20-001
855-93-xxx-20-001
855-99-xxx-20-001

Right angle receptacle: solder tail, triple row

Availability from: 6 to 150 contacts
Standard number of contacts 150

Series 850

PCB connectors 1.27 mm
Single row / double row
Surface mount

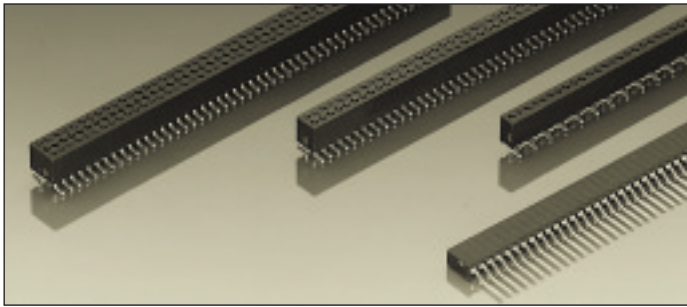



Ultraminiature PCB receptacles, surface mount



Grid spacing 1.27×1.27 mm
Receptacles for pins Ø 0.35–0.45 mm

For corresponding connectors see pages 13, 14 and 15

Platings	Sleeve 	Clip 	Pin 
91	5 µm Sn Pb	0.25 µm Au	
93	5 µm Sn Pb	0.75 µm Au	
99	5 µm Sn Pb	5 µm Sn Pb	

Ordering information

Replace **xxx** with the number of poles, e.g. 853-91-**xxx**-30-001 for a double row version with 8 pins per row becomes:
853-91-**016**-30-001

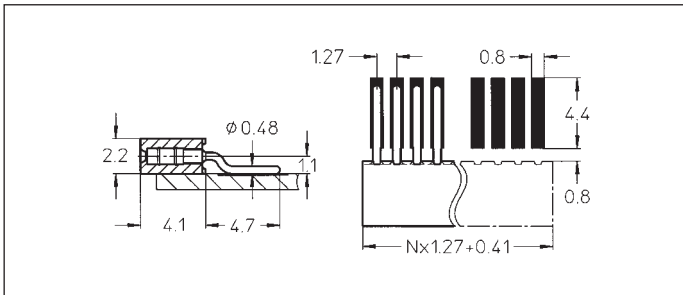

- 851-91-xxx-40-001
- 851-93-xxx-40-001
- 851-99-xxx-40-001

SMD receptacle: single row, parallel mount
Availability from: 1 to 50 contacts
Standard number of contacts 25 and 50

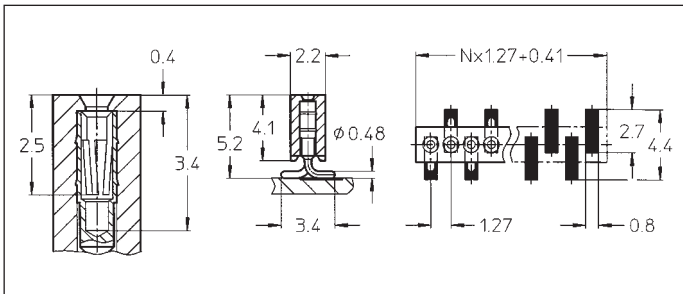

- 851-91-xxx-30-001
- 851-93-xxx-30-001
- 851-99-xxx-30-001

SMD receptacle: single row, perpendicular mount
Availability from: 3 to 50 contacts
Standard number of contacts single row: 25 and 50

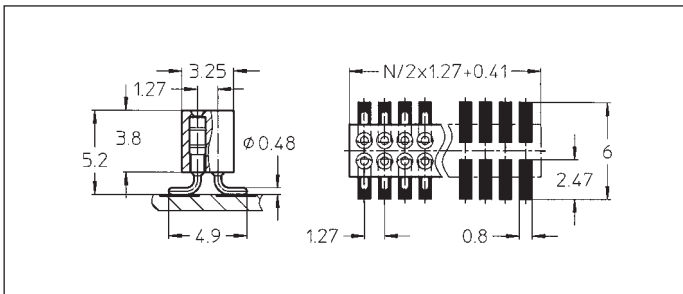

- 853-91-xxx-30-001
- 853-93-xxx-30-001
- 853-99-xxx-30-001

SMD receptacle: double row, perpendicular mount
Availability from: 4 to 100 contacts
Standard number of contacts 50 and 100

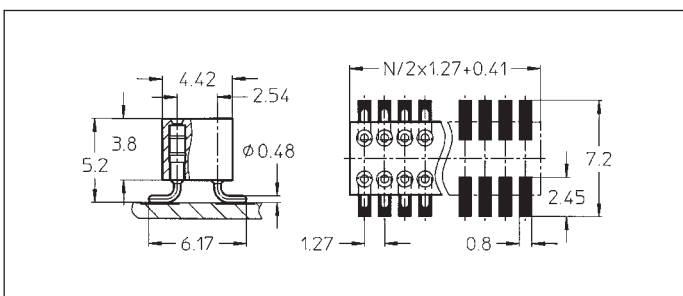

- 853-91-xxx-30-002
- 853-93-xxx-30-002
- 853-99-xxx-30-002

SMD receptacle: double row with 2.54 mm distance, perpendicular row to row mount
Availability from: 4 to 100 contacts
Standard number of contacts 100
On request with positioning pins

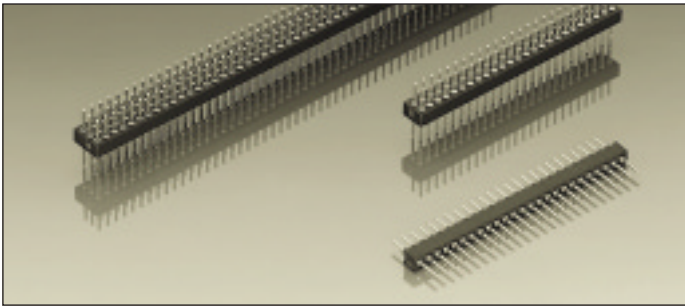

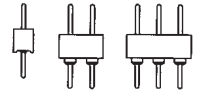

Ultraminiature PCB pin connectors, solder tail

Grid spacing 1.27×1.27 mm
Screw-machined pin Ø 0.43 mm



For corresponding receptacles see pages 10, 11 and 12

Platings	Sleeve 	Clip 	Pin 
10 90			0.25 µm Au 5 µm Sn Pb

Ordering information

Replace **xxx** with the number of poles, e.g. 852-10-**xxx**-10-001 for a double row version with 8 pins per row becomes:
852-10-**016**-10-001

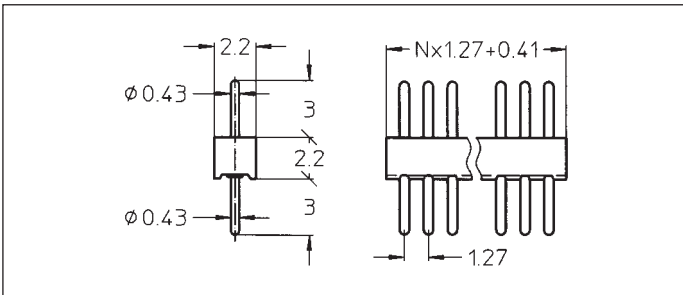

850-10-xxx-10-001
850-90-xxx-10-001

Straight pin connector: solder tail, single row
Availability from: 1 to 50 contacts
Standard number of contacts 25 and 50

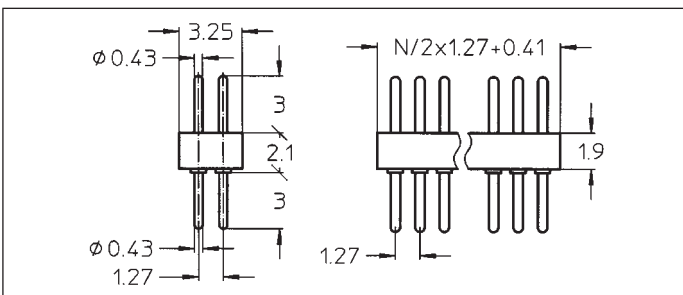

852-10-xxx-10-001
852-90-xxx-10-001

Straight pin connector: solder tail, double row
Availability from: 4 to 100 contacts
Standard number of contacts 50 and 100

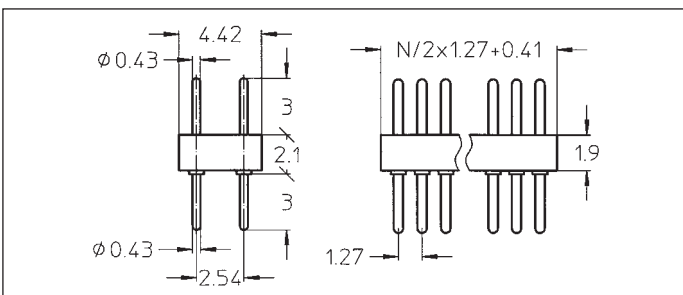

852-10-xxx-10-002
852-90-xxx-10-002

Straight pin connector: solder tail, double row with 2.54 mm row to row distance
Availability from: 4 to 100 contacts
Standard number of contacts 100

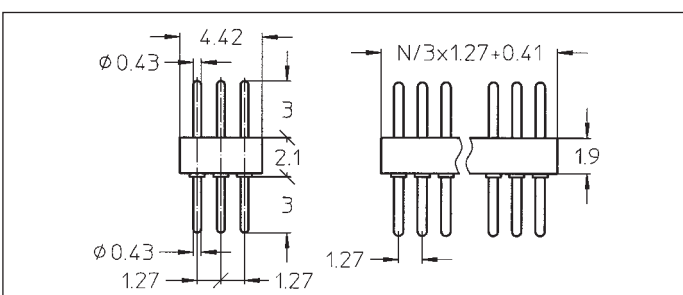

854-10-xxx-10-001
854-90-xxx-10-001

Straight pin connector: solder tail, triple row
Availability from: 9 to 150 contacts
Standard number of contacts 150

Series 850

PCB connectors 1.27 mm

Single row / double row / triple row

Solder tail

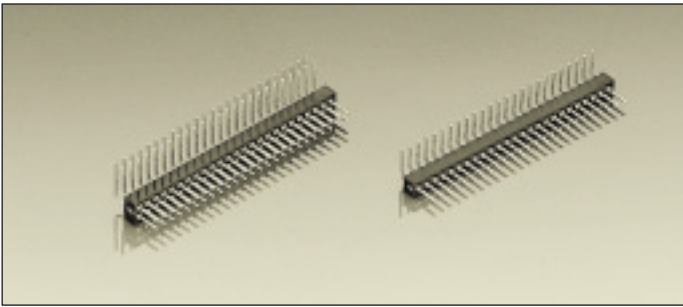

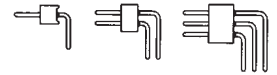

Ultraminiature PCB pin connectors, solder tail

Grid spacing 1.27×1.27 mm
Screw-machined pin \varnothing 0.43 mm

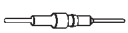

For corresponding receptacles see pages 10, 11 and 12

Platings	Sleeve 	Clip 	Pin 
10 90			0.25 μ m Au 5 μ m Sn Pb

Ordering information

Replace **xxx** with the number of poles, e.g. 852-10-**xxx**-20-001 for a double row version with 8 pins per row becomes:
852-10-**016**-20-001

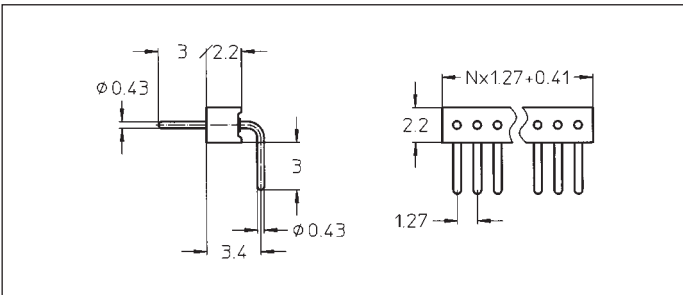

850-10-xxx-20-001
850-90-xxx-20-001

Right angle pin connector: solder tail, single row

Availability from: 1 to 50 contacts
Standard number of contacts 25 and 50

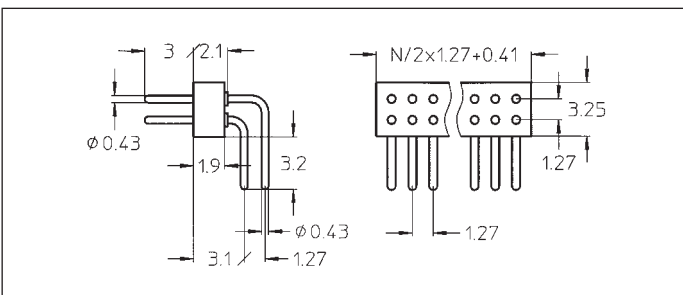

852-10-xxx-20-001
852-90-xxx-20-001

Right angle pin connector: solder tail, double row

Availability from: 4 to 100 contacts
Standard number of contacts 50 and 100

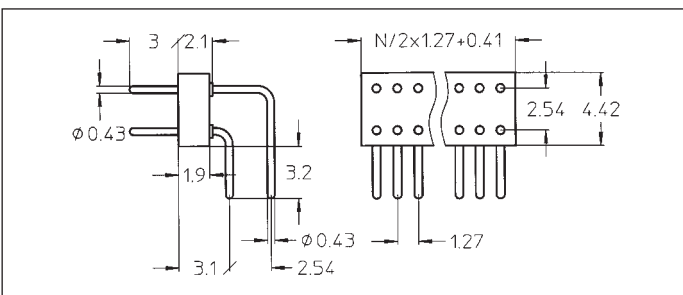

852-10-xxx-20-002
852-90-xxx-20-002

Right angle pin connector: solder tail, double row with 2.54 mm row to row distance

Availability from: 4 to 100 contacts
Standard number of contacts 100

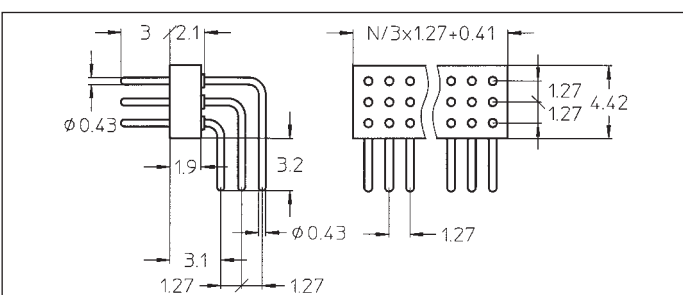

854-10-xxx-20-001
854-90-xxx-20-001

Right angle pin connector: solder tail, triple row

Availability from: 6 to 150 contacts
Standard number of contacts 150

Series 850

PCB connectors 1.27 mm
Single row / double row
Surface mount

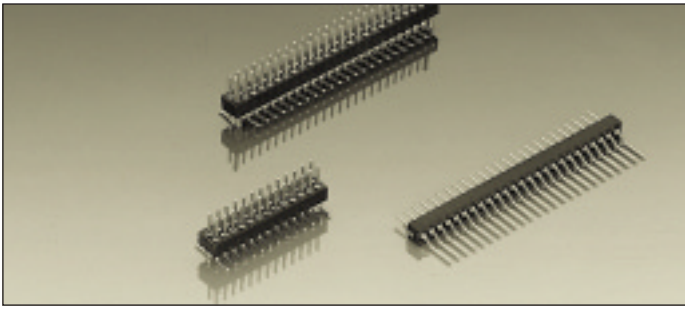

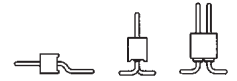

Ultraminiature PCB pin connectors, surface mount

Grid spacing 1.27x1.27 mm



Pin connectors with screw-machined pin \varnothing 0.43 mm

For corresponding connectors see pages 10, 11 and 12

Platings	Sleeve 	Clip 	Pin 
10 90			0.25 μ m Au 5 μ m Sn Pb

Ordering information

Replace **xxx** with the number of poles, e.g. 852-10-**xxx**-30-001 for a double row version with 8 pins per row becomes:
852-10-**016**-30-001

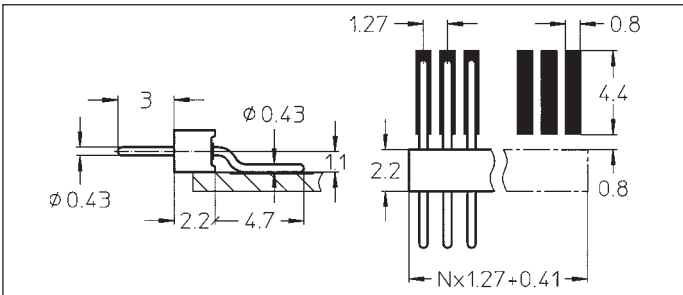

850-10-xxx-40-001
850-90-xxx-40-001

SMD pin connector: single row, parallel mount

Availability from: 1 to 50 contacts
Standard number of contacts 25 and 50

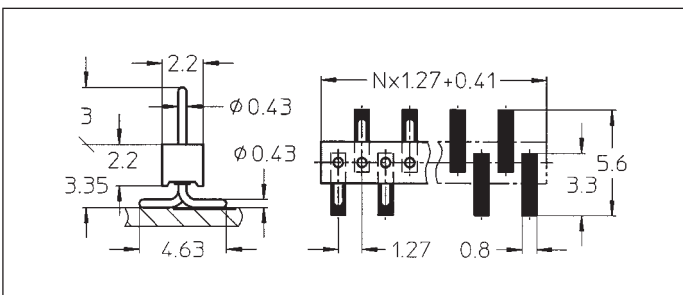

850-10-xxx-30-001
850-90-xxx-30-001

SMD pin connector: single and double row, perpendicular mount

Availability from: 3 to 50 contacts
Standard number of contacts 25 and 50

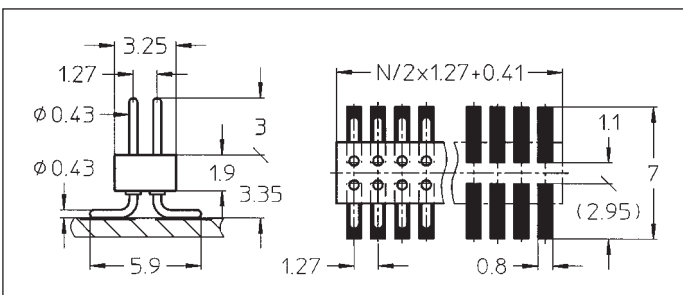

852-10-xxx-30-001
852-90-xxx-30-001

SMD pin connector: double row, perpendicular mount

Availability from: 4 to 100 contacts
Standard number of contacts 50 and 100

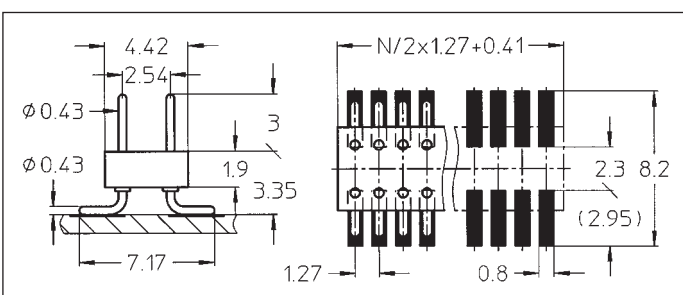

852-10-xxx-30-002
852-90-xxx-30-002

SMD pin connector: double row with 2.54 mm row to row distance, perpendicular mount

Availability from: 4 to 100 contacts
Standard number of contacts 100
On request with positioning pins

CONNECTOR WITH SPRING LOADED CONTACTS

Preci-Dip is introducing a new type of contact that can be proposed for connectors with very high cycle count in the range of 10 000 or more. The electrical connection is made with a spring loaded contact pin that is pressed against a fixed plate. The basic design is made to be easily adapted to various requirements of contact force and stroke, contact pitch and height of the connector.

Two different contact types are currently available:

- the original design for small pitch implementation down to 1.25 mm, and with solder tail
- a “very-low-profile” design with about 4.5 mm height with a working stroke of about 1mm; the min pitch is 2.54 mm and SMD termination.

Typical field of application:

- mobile phone, radio telephone and other portable telecom equipment
- battery loader for appliance, audio and video equipment
- portable computer (note book) and portable data acquisition and processing equipment
- test equipment.

Availability:

Samples for evaluation and functional tests available now.

Custom specific connector with new housing and/or particular connection side, but with the standard contact elements, please consult.

Contact with other specifications like stroke/force characteristics or electrical values on request.

Operating principle:

The electrical connection is made from the moving, spring actuated pin or plunger ① to the fixed wiring end of the connector ② by a multifinger sliding contact ③. The moving contact pin is actuated by a compression spring ④ assuring pressure against the fixed contact counterpart ⑤. Parts ① to ④ are fixed together by the plastic connector housing ⑥. Standard wiring is for PCB through hole soldering, but SMD version will be available.

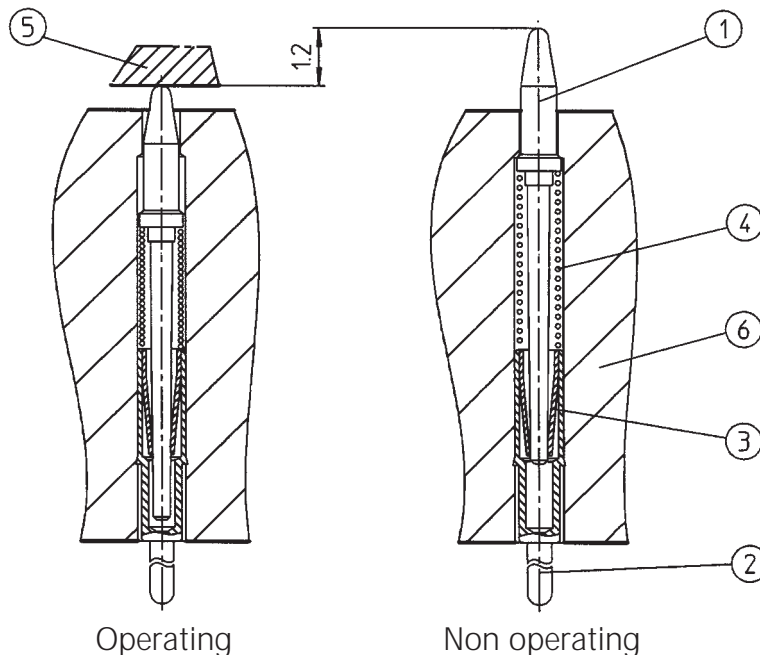

Series 317 / 350

PCB connectors 1.778 and 1.8 mm

Single row

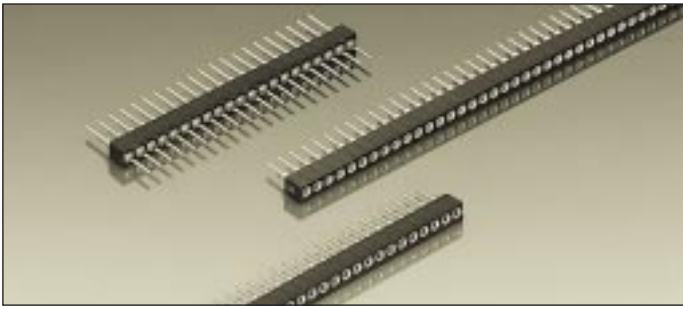

Solder tail



Receptacles and pin connectors, solder tail

With reduced grid spacing 1.778 and 1.8 mm

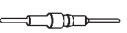

Platings	Sleeve 	Clip 	Pin 
91	5 µm Sn Pb	0,25 µm Au	0,25 µm Au 5 µm Sn Pb
93	5 µm Sn Pb	0,75 µm Au	
97	5 µm Sn Pb	Goldflash	
99	5 µm Sn Pb	5 µm Sn Pb	
10			
90			

Ordering information

Replace **xx** with the number of poles, e.g. 317-91-1**xx**-41-005 for a single row version with 8 contacts per row becomes: 317-91-**108**-41-005

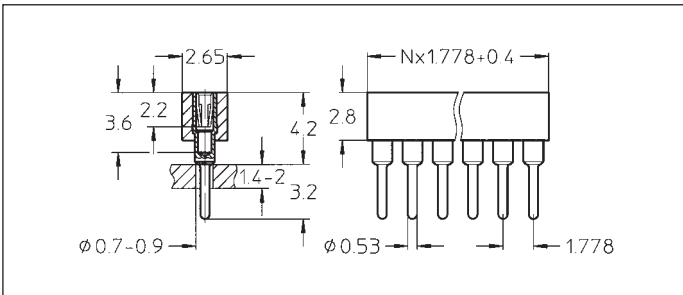

- 317-91-1xx-41-005
- 317-93-1xx-41-005
- 317-97-1xx-41-005
- 317-99-1xx-41-005

Straight receptacle: single row, accepts pin Ø 0.40–0.56 mm, grid spacing 1.778 mm

Availability from: 1 to 38 contacts
Standard number of contacts 21 and 38

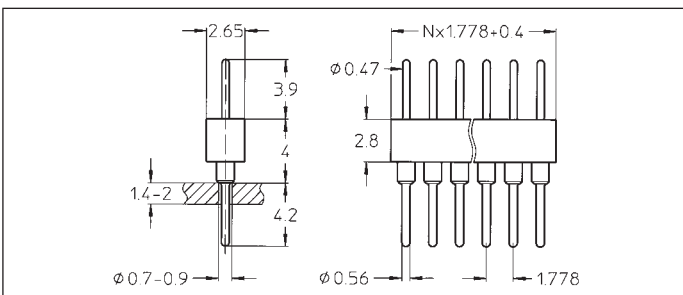

- 350-10-1xx-00-012
- 350-90-1xx-00-012

Straight pin connector: single row, grid spacing 1.778 mm, screw-machined pin Ø 0.47 mm

Availability from: 1 to 38 contacts
Standard number of contacts 21 and 38

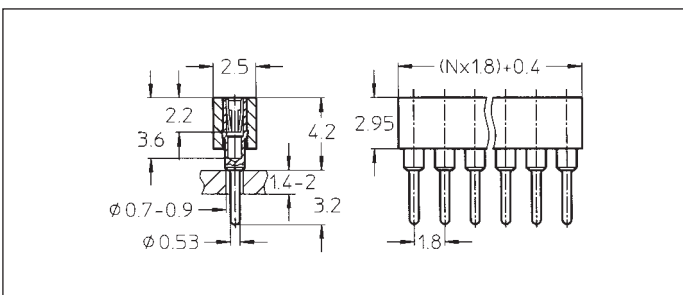

- 317-91-1xx-01-687
- 317-93-1xx-01-687
- 317-99-1xx-01-687

Straight receptacle: single row, accepts pin Ø 0.40–0.56 mm, grid spacing 1.8 mm for LCD-displays

Availability from: 1 to 42 contacts
Standard number of contacts 42

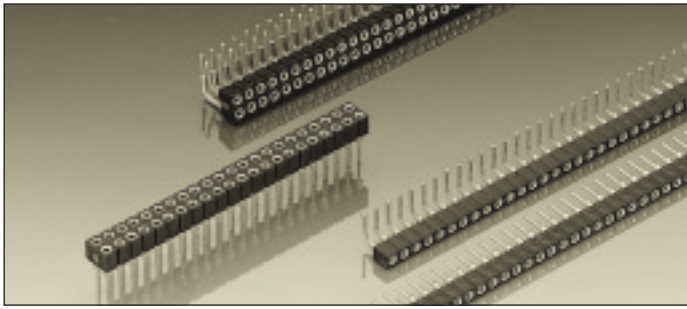

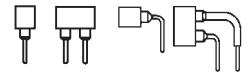

"Hard metric" PCB receptacles solder tail



Grid spacing 2.0x2.0 mm
 Receptacle for pins
 Ø 0.40-0.56 mm

For corresponding pin connectors see pages 19 and 20

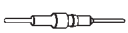
Platings	Sleeve 	Clip 	Pin 
91	5 µm Sn Pb	0.25 µm Au	
93	5 µm Sn Pb	0.75 µm Au	
99	5 µm Sn Pb	5 µm Sn Pb	

Ordering information

Replace **xxx** with the number of poles, e.g. 833-93-**xxx**-10-001 for a double row version with 8 pins per row becomes:
 833-93-**016**-10-001

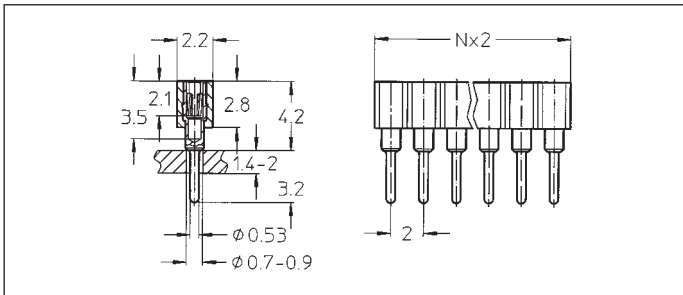

- 831-91-xxx-10-001
- 831-93-xxx-10-001
- 831-99-xxx-10-001

Straight receptacle: solder tail, single row
 Availability from: 1 to 50 contacts
 Standard number of contacts 50

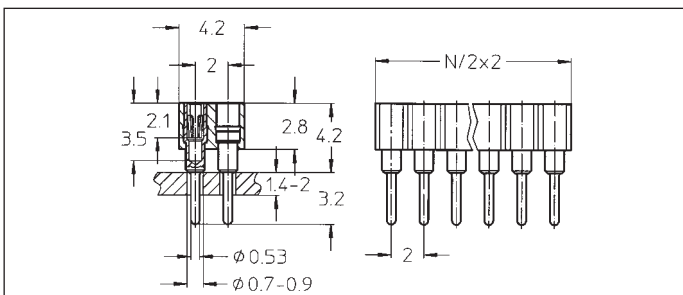

- 833-91-xxx-10-001
- 833-93-xxx-10-001
- 833-99-xxx-10-001

Straight receptacle: solder tail, double row
 Availability from: 4 to 100 contacts
 Standard number of contacts 100

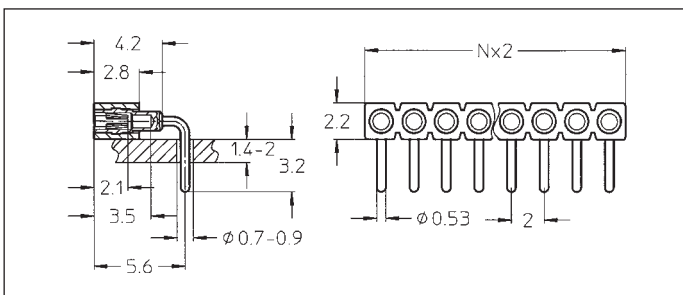

- 831-91-xxx-20-001
- 831-93-xxx-20-001
- 831-99-xxx-20-001

Right angle receptacle: solder tail, single row
 Availability from: 1 to 50 contacts
 Standard number of contacts 50

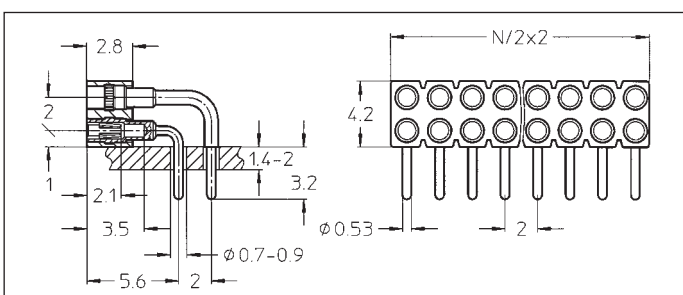

- 833-91-xxx-20-001
- 833-93-xxx-20-001
- 833-99-xxx-20-001

Right angle receptacle: solder tail, double row
 Availability from: 4 to 100 contacts
 Standard number of contacts 100

Series 830

PCB connectors 2.0 mm

Single row / double row

Solder tail

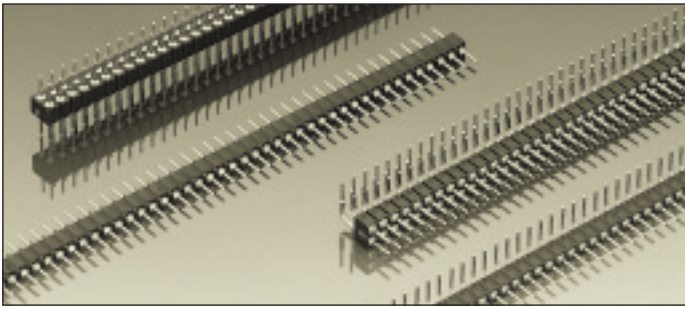

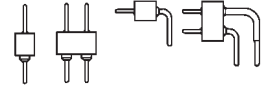

"Hard metric" PCB pin connectors, solder tail

Grid spacing 2.0×2.0 mm
Screw-machined pins
Ø 0.46–0.47 mm

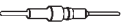

For corresponding receptacles see pages 18, 20 and 21

Platings	Sleeve 	Clip 	Pin 
10 90			0.25 µm Au 5 µm Sn Pb

Ordering information

Replace **xxx** with the number of poles, e.g. 832-10-**xxx**-20-001 for a double row version with 8 pins per row becomes:
832-10-**016**-20-001

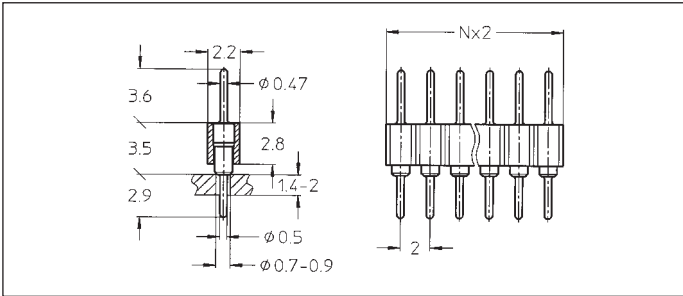

830-10-xxx-10-001
830-90-xxx-10-001

Straight pin connector: solder tail, single row
Availability from: 1 to 50 contacts
Standard number of contacts 50

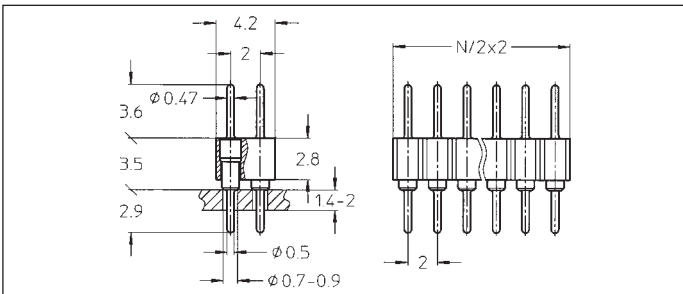

832-10-xxx-10-001
832-90-xxx-10-001

Straight pin connector: solder tail, double row
Availability from: 4 to 100 contacts
Standard number of contacts 100

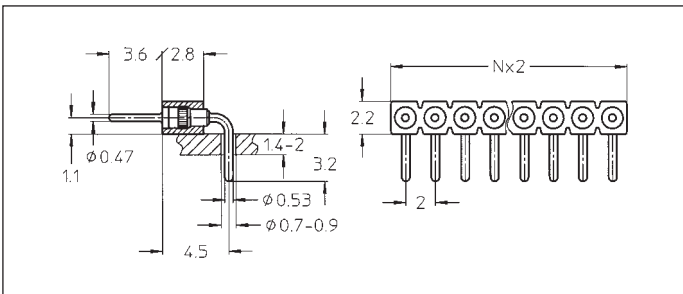

830-10-xxx-20-001
830-90-xxx-20-001

Right angle pin connector: solder tail, single row
Availability from: 1 to 50 contacts
Standard number of contacts 50

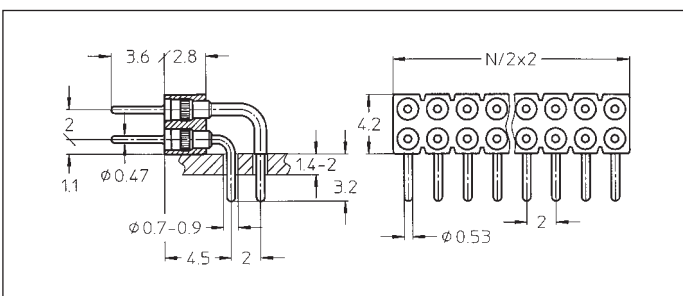

832-10-xxx-20-001
832-90-xxx-20-001

Right angle pin connector: solder tail, double row
Availability from: 4 to 100 contacts
Standard number of contacts 100

Series 830

PCB connectors 2.0 mm
Single row / double row
Surface mount

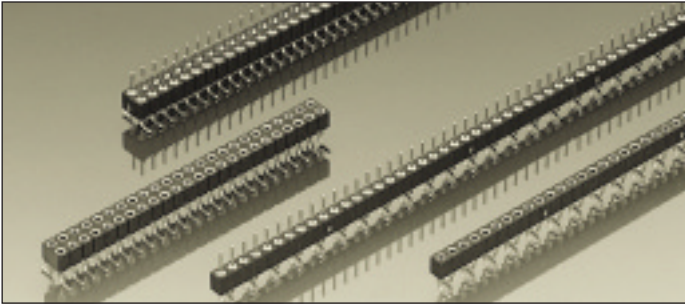

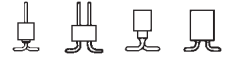

"Hard metric" PCB receptacles and pin connectors, surface mount



Grid spacing 2.0×2.0 mm
Receptacles for pins
Ø 0.40–0.56 mm

Screw machined pins Ø 0.46–0.47 mm

For corresponding connectors see pages 18, 19 and 21

Platings	Sleeve 	Clip 	Pin 
10			0.25 µm Au
90			5 µm Sn Pb
91	5 µm Sn Pb	0.25 µm Au	
93	5 µm Sn Pb	0.75 µm Au	
99	5 µm Sn Pb	5 µm Sn Pb	

Ordering information

Replace **xxx** with the number of poles, e.g. 833-91-**xxx**-30-001 for a double row version with 8 pins per row becomes:
833-91-**016**-30-001

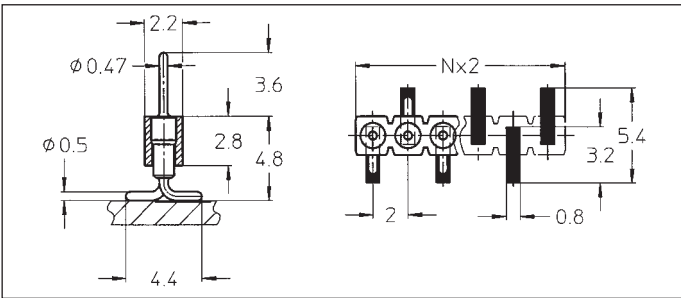

830-10-xxx-30-001
830-90-xxx-30-001

SMD pin connector: single row, perpendicular mount
Availability from: 3 to 50 contacts
Standard number of contacts 50

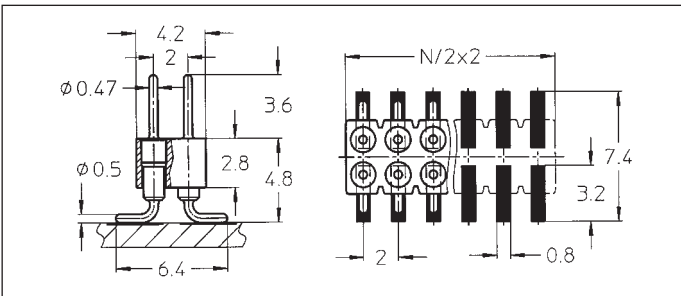

832-10-xxx-30-001
832-90-xxx-30-001

SMD pin connector: double row, perpendicular mount
Availability from: 4 to 100 contacts
Standard number of contacts 100

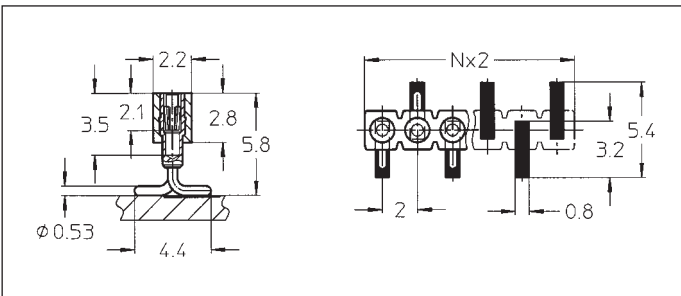

831-91-xxx-30-001
831-93-xxx-30-001
831-99-xxx-30-001

SMD receptacle: single row, perpendicular mount
Availability from: 3 to 50 contacts
Standard number of contacts 50

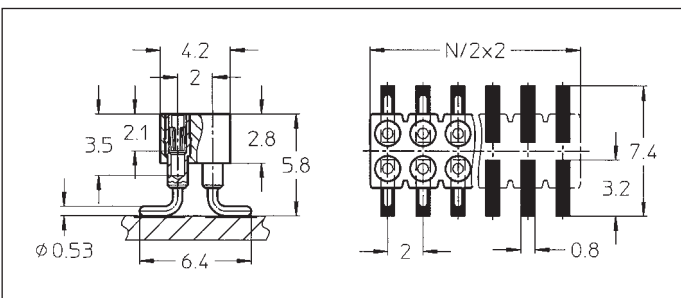

833-91-xxx-30-001
833-93-xxx-30-001
833-99-xxx-30-001

SMD receptacle: double row, perpendicular mount
Availability from: 4 to 100 contacts
Standard number of contacts 100

Series 830

PCB connectors 2.0 mm

Single row / double row

Press-fit

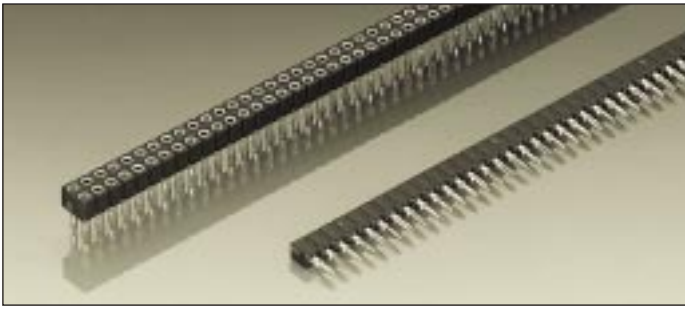

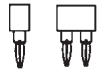

“Hard metric” PCB receptacles press-fit

Grid spacing 2.0×2.0 mm
 Receptacle for pins
 Ø 0.40–0.56 mm



For solderless mount into PCB with 1.5–2.4 mm thickness for plated thru-holes Ø 0.71±0.06 mm

For corresponding pin connectors see pages 19 and 20

Platings	Sleeve 	Clip 	Pin 
91	5 µm Sn Pb	0.25 µm Au	
93	5 µm Sn Pb	0.75 µm Au	
99	5 µm Sn Pb	5 µm Sn Pb	

Ordering information

Replace **xxx** with the number of poles, e.g. 833-93-**xxx**-64-001 for a double row version with 8 pins per row becomes:
 833-93-**016**-64-001

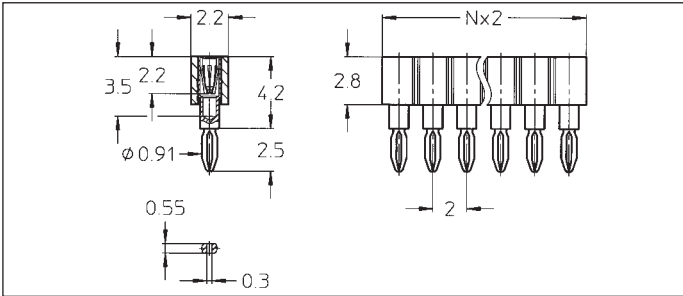

- 831-91-xxx-64-001
- 831-93-xxx-64-001
- 831-99-xxx-64-001

Straight receptacle: press-fit, single row
 Availability from: 1 to 50 contacts
 Standard number of contacts 50

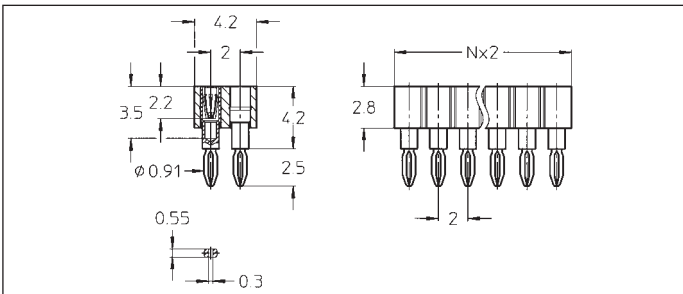

- 833-91-xxx-64-001
- 833-93-xxx-64-001
- 833-99-xxx-64-001

Straight receptacle: press-fit, double row
 Availability from: 4 to 100 contacts
 Standard number of contacts 100

Series 800

PCB connectors 2.54 mm

Single row / double row / triple row

Solder tail

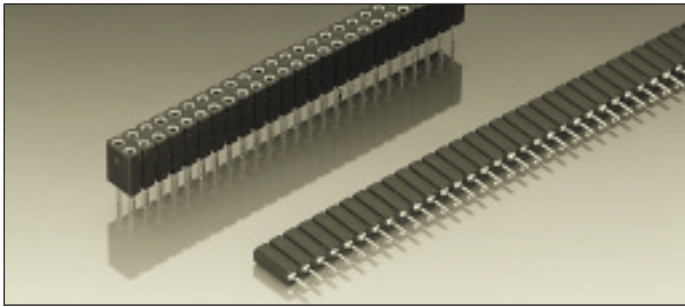

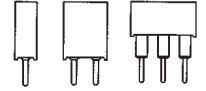

Receptacles, solder tail

Accept square pins $\square 0.635$ mm
and round pins $\varnothing 0.70-0.80$ mm

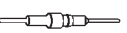

For corresponding pin connectors see
pages 30 to 35

Platings	Sleeve 	Clip 	Pin 
91	5 μ m Sn Pb	0.25 μ m Au	
93	5 μ m Sn Pb	0.75 μ m Au	
99	5 μ m Sn Pb	5 μ m Sn Pb	

Ordering information

Replace **xxx** with the number of poles, e.g. 803-91-**xxx**-10-001
for a double row version with 8 pins per row becomes:
803-91-**016**-10-001

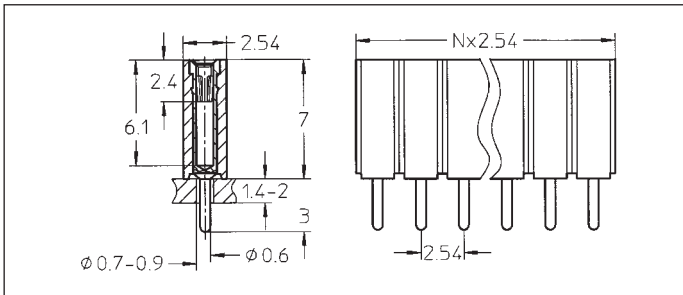

- 801-91-xxx-10-001
- 801-93-xxx-10-001
- 801-99-xxx-10-001

Straight receptacle: solder tail,
single row

Availability from: 1 to 50 contacts
Standard number of contacts 24,
28, 29, 30, 36, 42, 48, 50

Option
On request with clinched
(right/left) solder tails

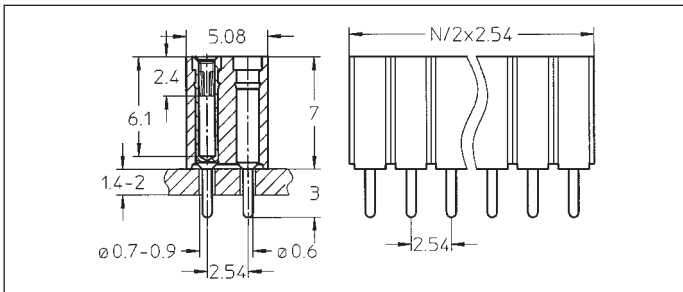

- 803-91-xxx-10-001
- 803-93-xxx-10-001
- 803-99-xxx-10-001

Straight receptacle: solder tail,
double row

Availability from: 4 to 100
contacts
Standard number of contacts 72
and 100

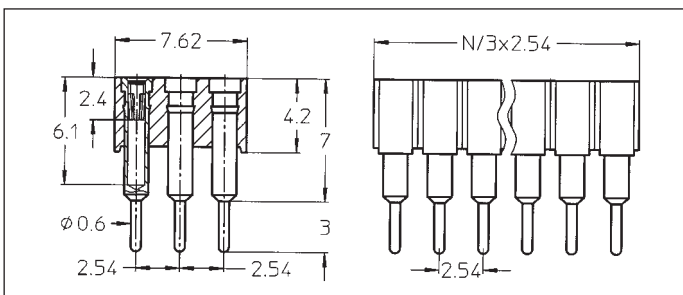

- 805-91-xxx-10-001
- 805-93-xxx-10-001
- 805-99-xxx-10-001

Straight receptacle: solder tail,
triple row

Availability from: 9 to 96 contacts
Standard number of contacts 96

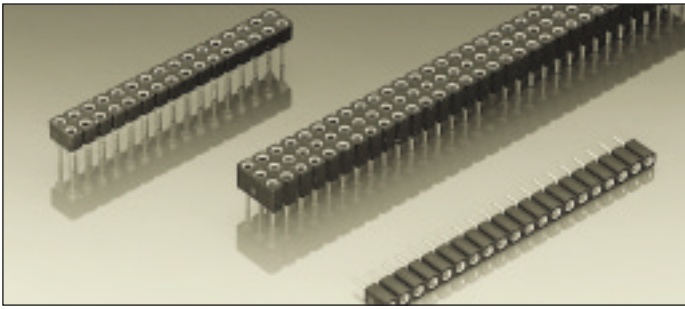

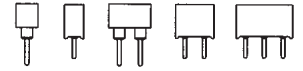

Receptacles, solder tail

Accept square pins $\square 0.635$ mm
and round pins $\varnothing 0.70-0.80$ mm

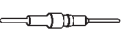

For corresponding pin connectors see
pages 30 to 35

Platings	Sleeve 	Clip 	Pin 
91	5 μ m Sn Pb	0.25 μ m Au	
93	5 μ m Sn Pb	0.75 μ m Au	
99	5 μ m Sn Pb	5 μ m Sn Pb	

Ordering information

Replace **xxx** with the number of poles, e.g. 803-91-**xxx**-10-012
for a double row version with 8 pins per row becomes:
803-91-**016**-10-012

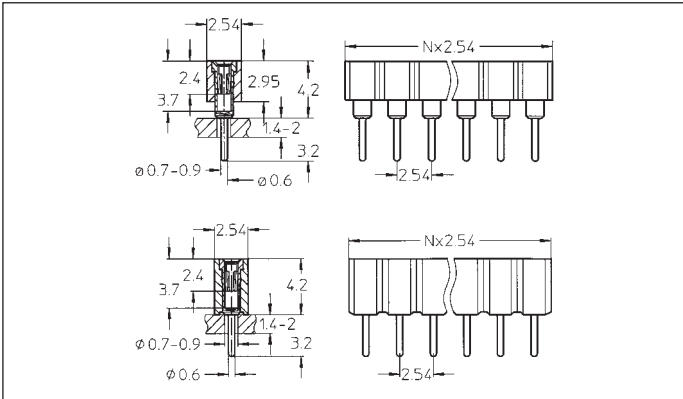

- 801-91-xxx-10-002 **B**
- 801-93-xxx-10-002 **B**
- 801-99-xxx-10-002 **B**

Straight receptacle: solder tail,
single row, low profile
h = 4.2 mm

...-002: Availability from: 1 to 64
contacts
Standard number of contacts 64

- 801-91-xxx-10-012
- 801-93-xxx-10-012
- 801-99-xxx-10-012

...-012: Availability from: 1 to 32
contacts
Standard number of contacts 14,
20 and 32

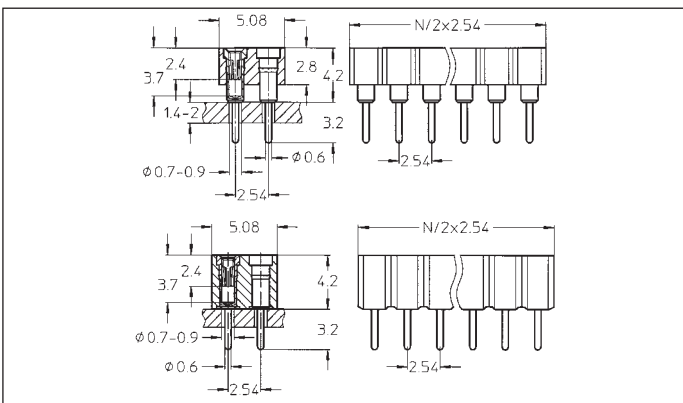

- 803-91-xxx-10-002 **B**
- 803-93-xxx-10-002 **B**
- 803-99-xxx-10-002 **B**

Straight receptacle: solder tail,
double row, low profile
h = 4.2 mm

...-002: Availability from: 4 to 72
contacts
Standard number of contacts 40,
44, 56, 64 and 72

- 803-91-xxx-10-012
- 803-93-xxx-10-012
- 803-99-xxx-10-012

...-012: Availability from: 4 to 64
contacts
Standard number of contacts 64

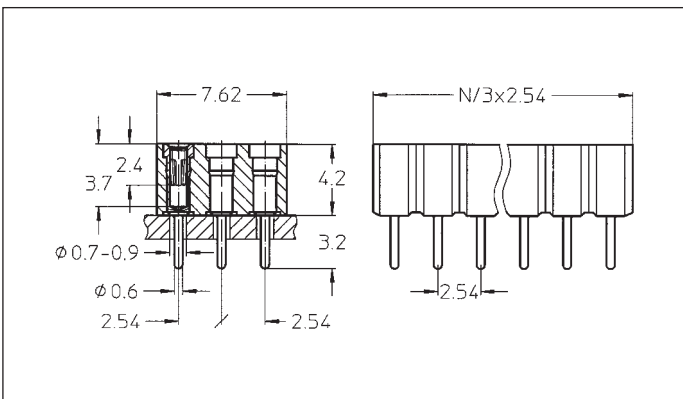

- 805-91-xxx-10-012
- 805-93-xxx-10-012
- 805-99-xxx-10-012

Straight receptacle: solder tail,
triple row, low profile
h = 4.2 mm

Availability from: 9 to 96 contacts
Standard number of contacts 96

Series 800

PCB connectors 2.54 mm
Single row / double row
Solder tail

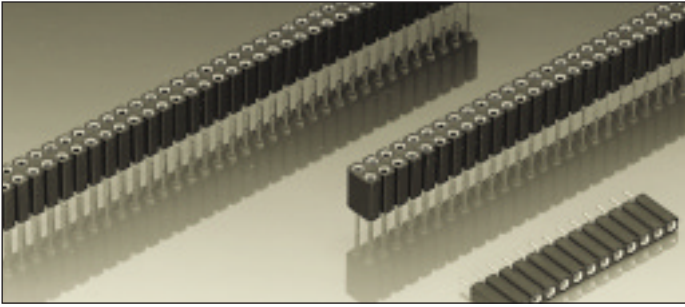

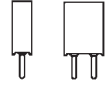

Receptacles, solder tail

Accept square pins \square 0.635 mm
and round pins \varnothing 0.70–0.80 mm

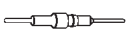

For corresponding pin connectors see pages 30 to 35

Platings	Sleeve 	Clip 	Pin 
91	5 μ m Sn Pb	0.25 μ m Au	
93	5 μ m Sn Pb	0.75 μ m Au	
99	5 μ m Sn Pb	5 μ m Sn Pb	

Ordering information

Replace **xxx** with the number of poles, e.g. 803-91-**xxx**-10-003
for a double row version with 8 pins per row becomes:
803-91-**016**-10-003

Option:

Triple row on request

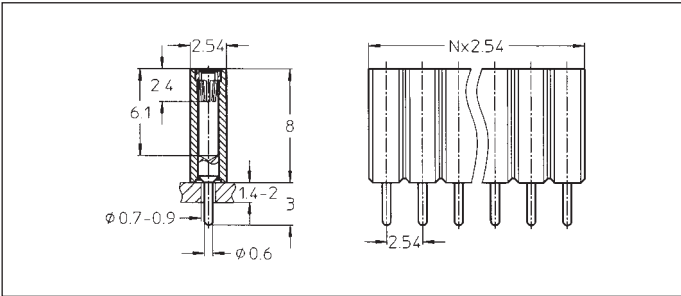

- 801-91-xxx-10-003
- 801-93-xxx-10-003
- 801-99-xxx-10-003

Straight receptacle height 8 mm:
solder tail, single row
Availability from: 1 to 36 contacts
Standard number of contacts 36

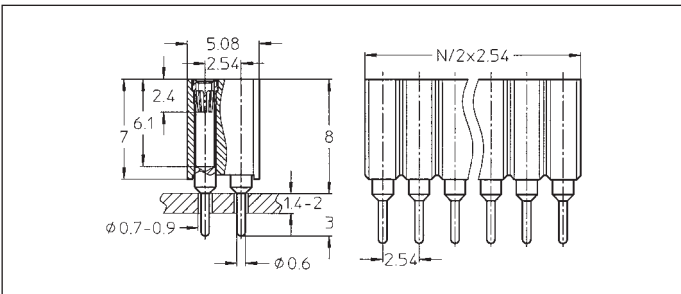

- 803-91-xxx-10-003
- 803-93-xxx-10-003
- 803-99-xxx-10-003

Straight receptacle height 8 mm:
solder tail, double row
Availability from: 4 to 100
contacts
Standard number of contacts 72
and 100

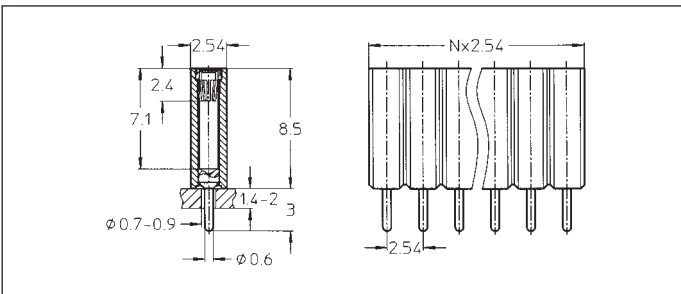

- 801-91-xxx-10-005
- 801-93-xxx-10-005
- 801-99-xxx-10-005

Straight receptacle height
8.5 mm: solder tail, single row
Availability from: 1 to 36 contacts
Standard number of contacts 36

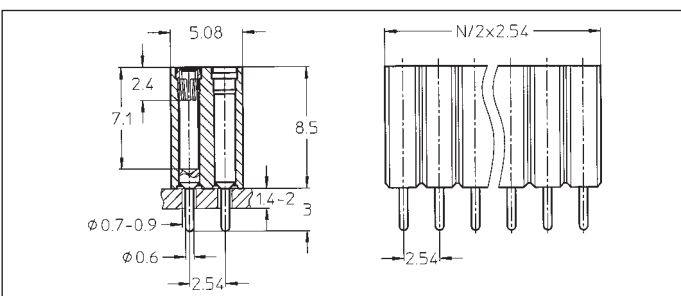

- 803-91-xxx-10-005
- 803-93-xxx-10-005
- 803-99-xxx-10-005

Straight receptacle height
8.5 mm: solder tail, double row
Availability from: 4 to 100
contacts
Standard number of contacts 100

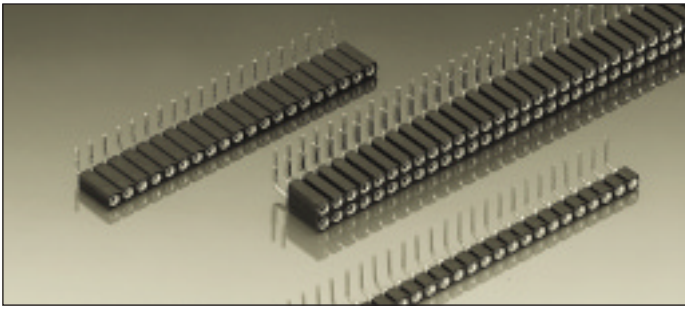

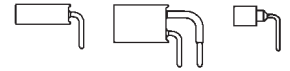

Right angle receptacles, solder tail



Receptacles accept square pins \square 0.635 mm and round pins \varnothing 0.70–0.80 mm

For corresponding receptacle connectors see pages 30 to 35

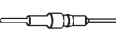
Platings	Sleeve 	Clip 	Pin 
91	5 μ m Sn Pb	0.25 μ m Au	
93	5 μ m Sn Pb	0.75 μ m Au	
99	5 μ m Sn Pb	5 μ m Sn Pb	

Ordering information

Replace **xxx** with the number of poles, e.g. 803-91-**xxx**-20-001 for a double row version with 8 pins per row becomes: 803-91-**016**-20-001

Option:

Triple row right angle receptacles on request

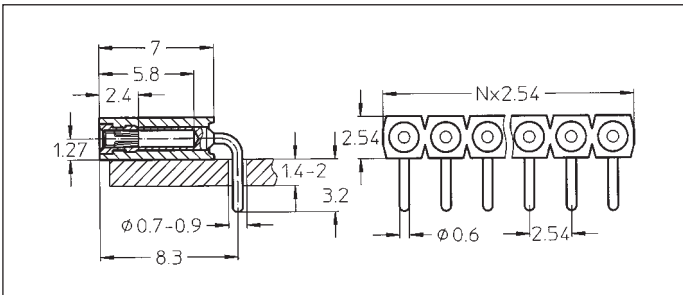

801-91-xxx-20-001
801-93-xxx-20-001
801-99-xxx-20-001

Right angle receptacle: solder tail, single row

Availability from: 1 to 50 contacts
Standard number of contacts 24, 28, 29, 30, 36, 42, 48, 50

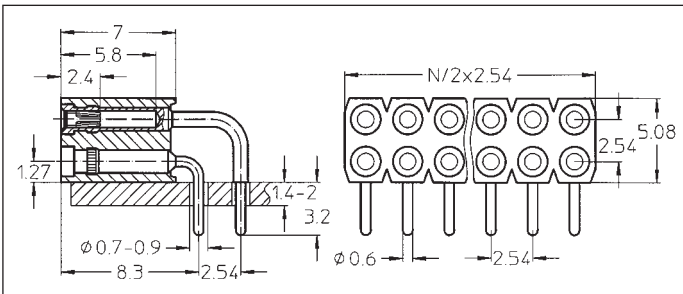

803-91-xxx-20-001
803-93-xxx-20-001
803-99-xxx-20-001

Right angle receptacle: solder tail, double row

Availability from: 4 to 100 contacts
Standard number of contacts 72 and 100

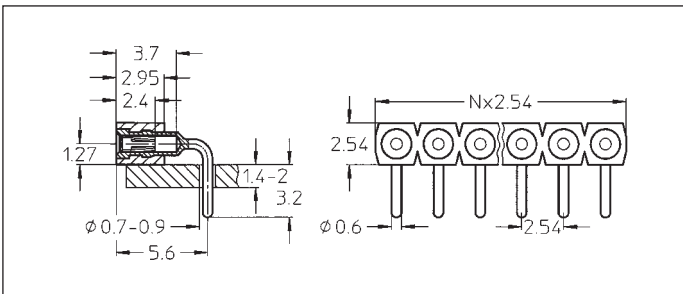

801-91-xxx-20-002
801-93-xxx-20-002
801-99-xxx-20-002

Right angle short receptacle: solder tail, single row

Availability from: 1 to 64 contacts
Standard number of contacts: 64

Right angle short receptacle: solder tail, double row available on request
Please consult

Series 800

PCB connectors 2.54 mm
Single row / double row
Surface mount

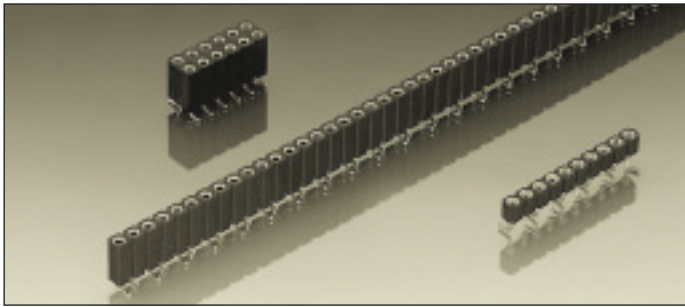

Receptacles, surface mount

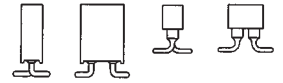

Accept square pins \square 0.635 mm
and round pins \varnothing 0.70–0.80 mm



For corresponding pin connectors see
pages 30 to 35

Ordering information

Replace **xxx** with the number of poles, e.g. 803-91-**xxx**-30-001
for a double row version with 8 pins per row becomes:
803-91-**016**-30-001

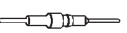
Platings	Sleeve 	Clip 	Pin 
91	5 μ m Sn Pb	0.25 μ m Au	
93	5 μ m Sn Pb	0.75 μ m Au	
99	5 μ m Sn Pb	5 μ m Sn Pb	

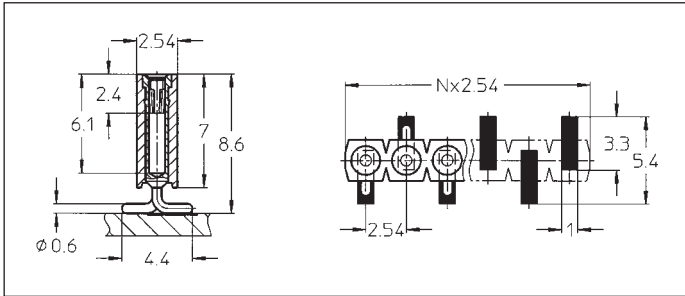

- 801-91-xxx-30-001
- 801-93-xxx-30-001
- 801-99-xxx-30-001

SMD receptacle: single row
perpendicular mount

Availability from: 3 to 50 contacts
Standard number of contacts 24,
28, 29, 30, 36, 42, 48 and 50

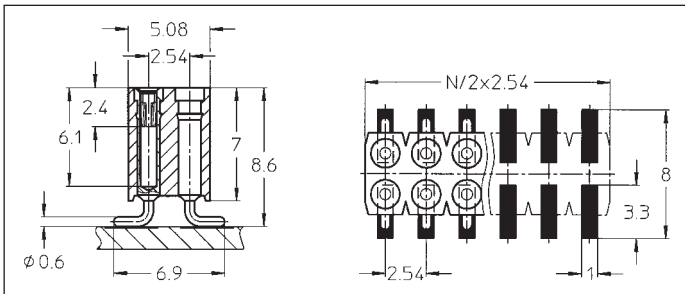

- 803-91-xxx-30-001
- 803-93-xxx-30-001
- 803-99-xxx-30-001

SMD receptacle: double row
perpendicular mount

Availability from: 4 to 100
contacts
Standard number of contacts 72
and 100

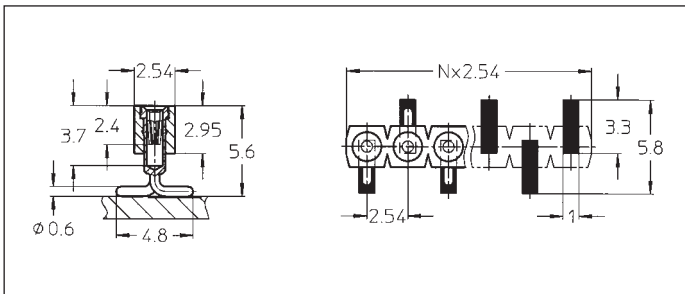

- 801-91-xxx-30-002
- 801-93-xxx-30-002
- 801-99-xxx-30-002

SMD receptacle: single row, low
profile, perpendicular mount

Availability from: 3 to 32 contacts
Standard number of contacts 32

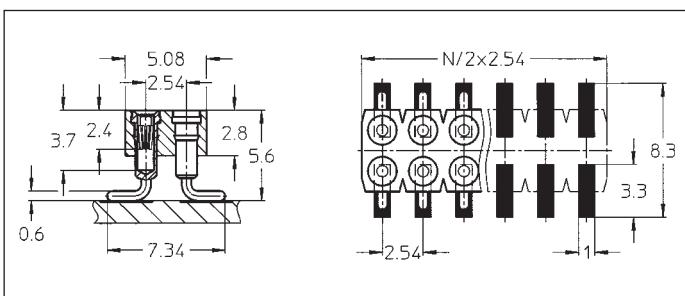

- 803-91-xxx-30-002
- 803-93-xxx-30-002
- 803-99-xxx-30-002

SMD receptacle: double row, low
profile, perpendicular mount

Availability from: 4 to 72 contacts
Standard number of contacts 40,
44, 56, 64 and 72

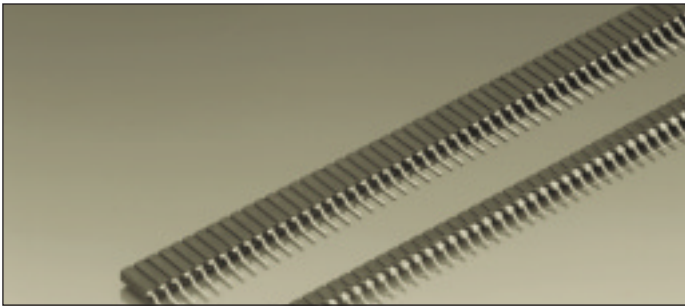



Receptacles, surface mount



Accept square pins \square 0.635 mm
and round pins \varnothing 0.70–0.80 mm

For corresponding pin connectors see
pages 30 to 35

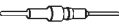
Platings	Sleeve 	Clip 	Pin 
91	5 μ m Sn Pb	0.25 μ m Au	
93	5 μ m Sn Pb	0.75 μ m Au	
99	5 μ m Sn Pb	5 μ m Sn Pb	

Ordering information

Replace **xxx** with the number of poles, e.g. 803-91-**xxx**-40-001
for a double row version with 8 pins per row becomes:
803-91-**016**-40-001

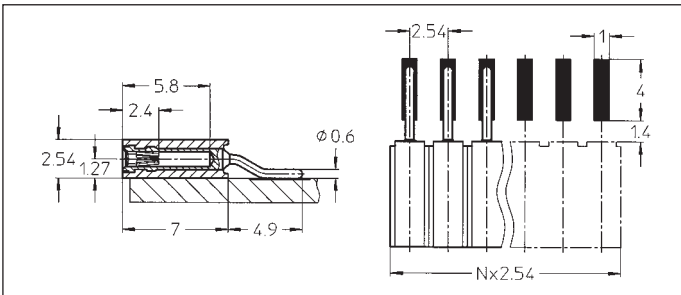

- 801-91-xxx-40-001
- 801-93-xxx-40-001
- 801-99-xxx-40-001

SMD receptacle: single row
parallel mount

Availability from: 1 to 50 contacts
Standard number of contacts 24,
28, 29, 30, 36, 42, 48 and 50

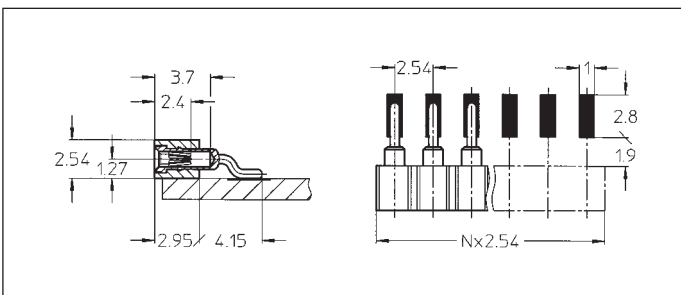

- 801-91-xxx-40-002
- 801-93-xxx-40-002
- 801-99-xxx-40-002

SMD receptacle: single row, low
profile, parallel mount

Availability from: 1 to 32 contacts
Standard number of contacts 32

Series 800

PCB connectors 2.54 mm

Single row / double row

Press-fit

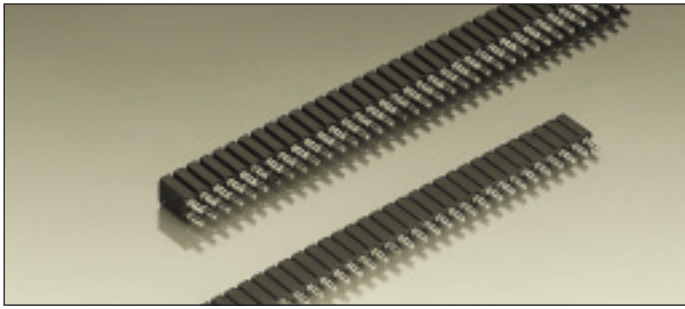

Receptacles connectors, press-fit

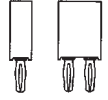

Receptacles accept square pins
 \square 0.635 mm, and round pins \varnothing 0.70–0.80 mm



With compliant pin for solderless mount into PCB
 plated-thru holes \varnothing 1 mm + 0.09/–0.06 mm

For corresponding connectors see pages 30 to 35

New version with modified eye of the needle pin

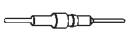
Platings	Sleeve 	Clip 	Pin 
91	5 μ m Sn Pb	0.25 μ m Au	
93	5 μ m Sn Pb	0.75 μ m Au	
99	5 μ m Sn Pb	5 μ m Sn Pb	

Ordering information

Replace **xxx** with the number of poles, e.g. 803-93-**xxx**-65-001
 for a double row version with 8 pins per row becomes:
 803-93-**016**-65-001

(Older versions 801/803-...-61/62/63-001 please consult)

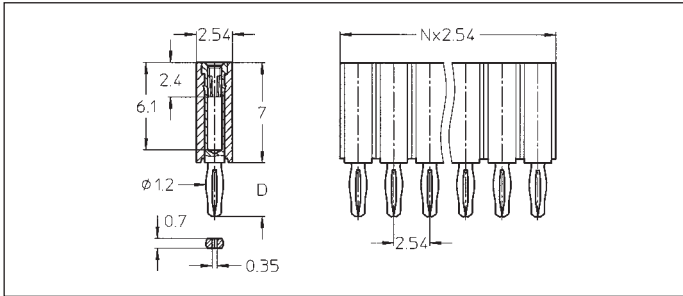

for PCB thickness 1.5 to 2.0 mm D = 2.80 mm
 801-91-xxx-65-001
 801-93-xxx-65-001
 801-99-xxx-65-001

for PCB thickness 2.1 to 3.2 mm D = 3.80 mm
 801-91-xxx-66-001
 801-93-xxx-66-001
 801-99-xxx-66-001

Press-fit receptacle: single row
 Availability from: 1 to 50 contacts
 Standard number of contacts 24,
 28, 29, 30, 36, 42, 48, 50

New version with modified eye of the needle pin

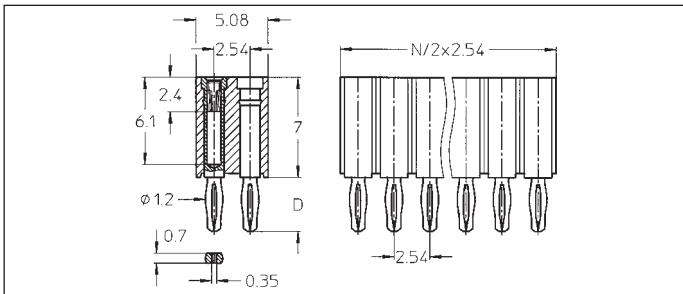

for PCB thickness 1.5 to 2.0 mm D = 2.80 mm
 803-91-xxx-65-001
 803-93-xxx-65-001
 803-99-xxx-65-001

for PCB thickness 2.1 to 3.2 mm D = 3.80 mm
 803-91-xxx-66-001
 803-93-xxx-66-001
 803-99-xxx-66-001

Press-fit receptacle: double row
 Availability from: 4 to 100 contacts
 Standard number of contacts 72
 and 100

New version with modified eye of the needle pin

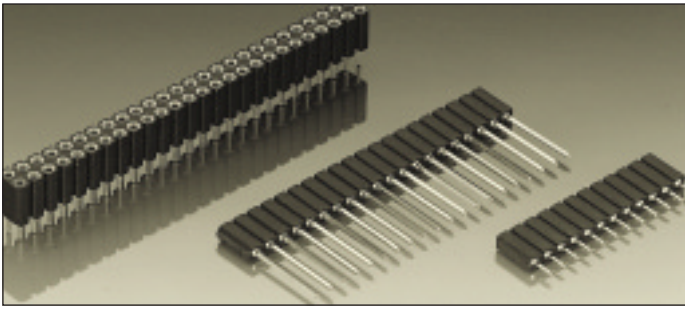

PCB receptacles with wire-wrap posts

Accept square pins \square 0.635 mm
and round pins \varnothing 0.70–0.80 mm

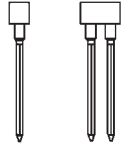

For corresponding pin connectors see pages
30 to 35

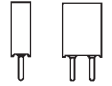

Receptacles, solder tail

for pins \varnothing 0.95–1.05 mm



Platings	Sleeve 	Clip 	Pin 
91	5 μ m Sn Pb	0.25 μ m Au	
93	5 μ m Sn Pb	0.75 μ m Au	
99	5 μ m Sn Pb	5 μ m Sn Pb	

Ordering information

Replace **xxx** with the number of poles, e.g. 803-91-**xxx**-10-004
for a double row version with 8 pins per row becomes:
803-91-**016**-10-004

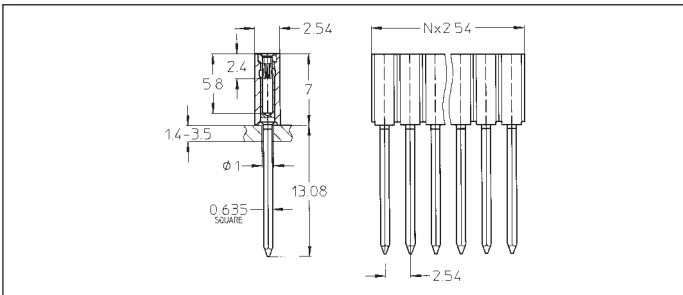

801-91-xxx-53-001 **B**
801-93-xxx-53-001

Wire-wrap receptacle: single row,
3 levels

Availability from: 1 to 50 contacts
Standard number of contacts 24,
28, 29, 30, 36, 42, 48, 50

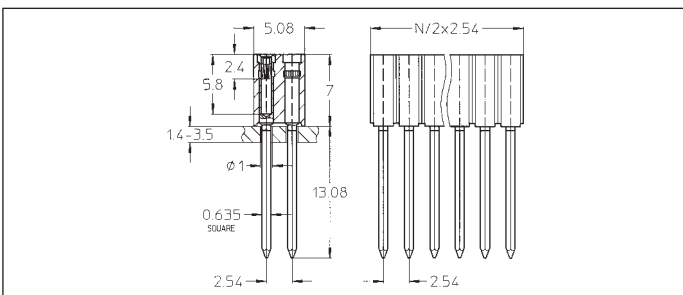

803-91-xxx-53-001 **B**
803-93-xxx-53-001

Wire-wrap receptacle: double
row, 3 levels

Availability from: 4 to 100
contacts
Standard number of contacts 72
and 100

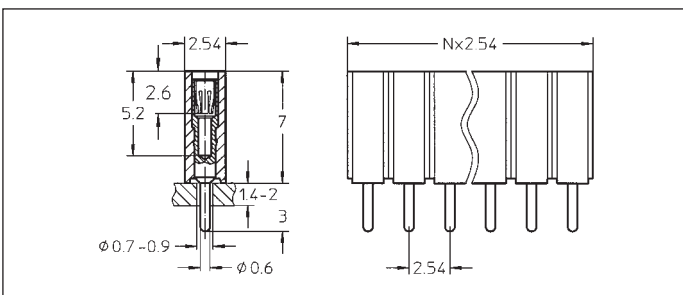

801-91-xxx-10-004
801-93-xxx-10-004
801-99-xxx-10-004

Straight receptacle: single row,
accepts pin
 \varnothing 0.95–1.05 mm

Availability from: 1 to 50 contacts
Standard number of contacts 24,
28, 29, 30, 36, 42, 48, 50

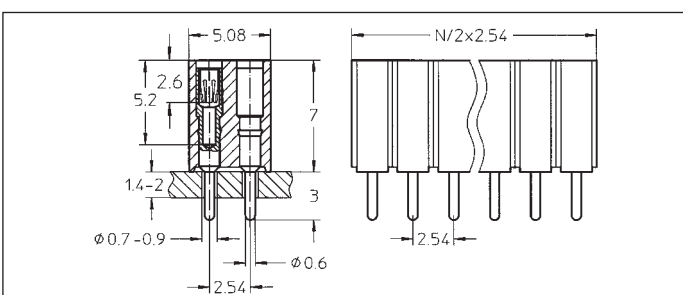

803-91-xxx-10-004
803-93-xxx-10-004
803-99-xxx-10-004

Straight receptacle: double row,
accepts pin
 \varnothing 0.95–1.05 mm

Availability from: 4 to 100
contacts
Standard number of contacts 72
and 100

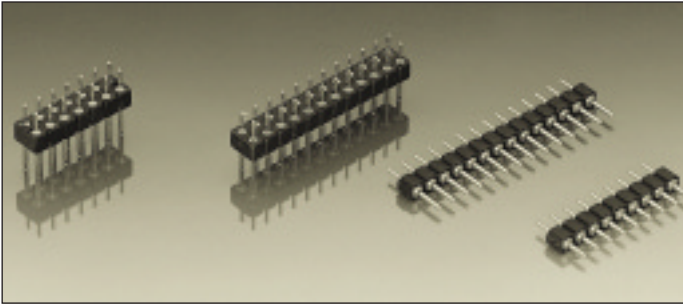

Pin connectors, solder tail

Screw-machined pins $\varnothing 0.76$ mm





For corresponding receptacles see pages 22 to 29

New:

Pin connectors with selective plated precision screw machined pin, plating code Z1.

Connecting side 1: gold plated
soldering/PCB side 2: tin plated

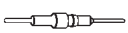
Platings	Sleeve 	Clip 	Pin 
10 90 Z1			0.25 μ m Au 5 μ m Sn Pb 1: 0.25 μ m Au 2: 5 μ m Sn Pb

Ordering information

Replace **xx** with the number of poles, e.g. 802-10-**0xx**-10-001 for a double row version with 8 pins per row becomes:
802-10-**016**-10-001

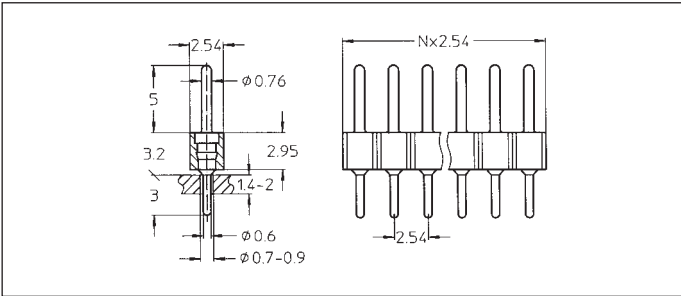

800-10-0xx-10-001
800-90-0xx-10-001
800-Z1-0xx-10-001

Straight pin connector: solder tail, single row

Availability from: 1 to 64 contacts
Standard number of contacts 5, 6, 8, 10, 14, 16, 20, 21, 25, 30, 32, 48, 56, 60, 64

Option
On request with clinched (right/left) solder tails

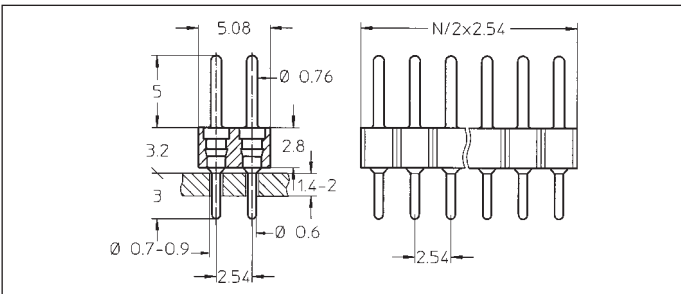

802-10-0xx-10-001
802-90-0xx-10-001
802-Z1-0xx-10-001

Straight pin connector: solder tail, double row

Availability from: 4 to 72 contacts
Standard number of contacts 40, 44, 56, 64, 72

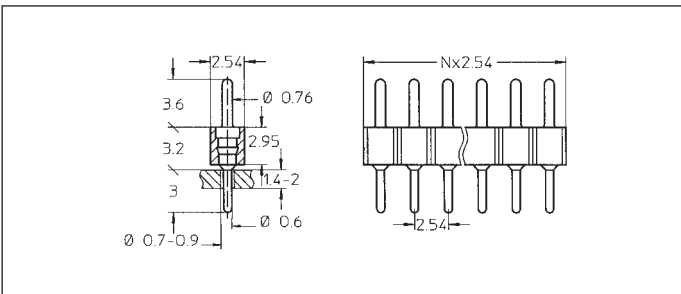

800-10-0xx-10-002
800-90-0xx-10-002
800-Z1-0xx-10-002

Straight pin connector: solder tail, single row, short pin

Availability from: 1 to 64 contacts
Standard number of contacts 5, 6, 8, 10, 14, 16, 20, 21, 25, 30, 32, 48, 56, 60, 64

Option
On request with clinched (right/left) solder tails

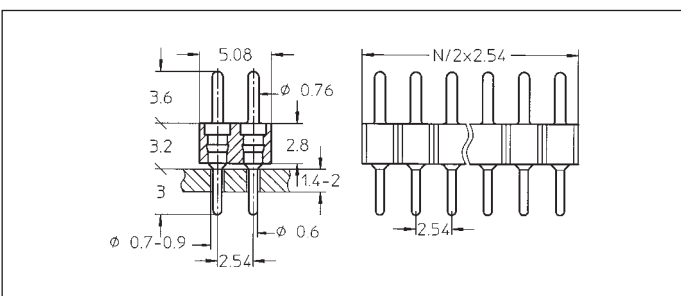

802-10-0xx-10-002
802-90-0xx-10-002
802-Z1-0xx-10-002

Straight pin connector: solder tail, double row, short pin

Availability from: 4 to 72 contacts
Standard number of contacts 40, 44, 56, 64, 72

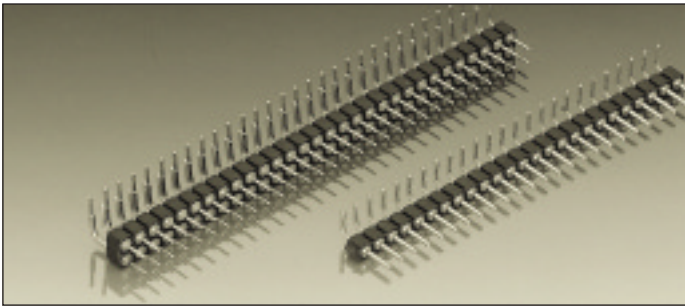

Right angle pin connectors, solder tail

Screw-machined pins \varnothing 0.76 mm

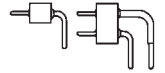



For corresponding receptacles see pages 22 to 29

New:

Pin connectors with selective plated precision screw machined pin, plating code Z1.

Connecting side 1: gold plated
soldering/PCB side 2: tin plated

Platings	Sleeve 	Clip 	Pin 
10 90 Z1			0.25 μ m Au 5 μ m Sn Pb 1: 0.25 μ m Au 2: 5 μ m Sn Pb

Ordering information

Replace **xx** with the number of poles, e.g. 802-10-**0xx**-20-001 for a double row version with 8 pins per row becomes:
802-10-**016**-20-001

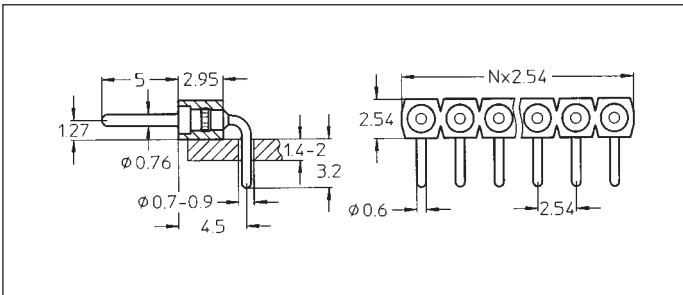

800-10-0xx-20-001
800-90-0xx-20-001
800-Z1-0xx-20-001

Right angle pin connector: solder tail, single row

Availability from: 1 to 64 contacts
Standard number of contacts 5, 6, 8, 10, 14, 16, 20, 21, 25, 30, 32, 48, 56, 60, 64

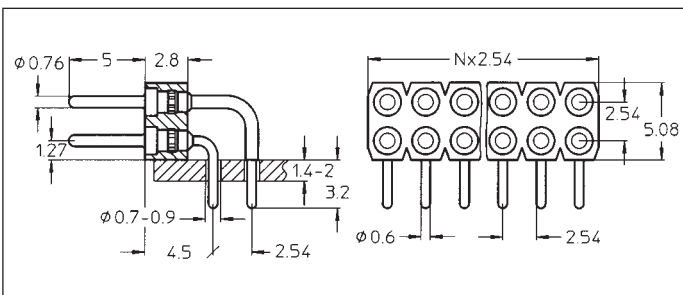

802-10-0xx-20-001
802-90-0xx-20-001
802-Z1-0xx-20-001

Right angle pin connector: solder tail, double row

Availability from: 4 to 72 contacts
Standard number of contacts 40, 44, 56, 64, 72

Series 800

PCB connectors 2.54 mm

Single row / double row

Surface mount

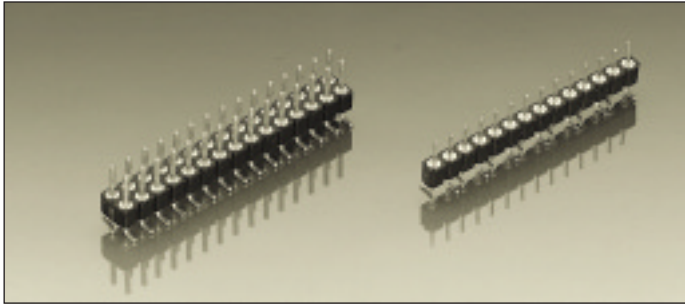

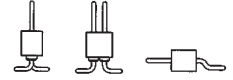

Pin connectors, surface mount

Screw-machined pins \varnothing 0.76 mm
For corresponding receptacles see pages 22 to 29



New:

Pin connectors with selective plated precision screw machined pin, plating code Z1.
Connecting side 1: gold plated
soldering/PCB side 2: tin plated

Platings	Sleeve 	Clip 	Pin 
10 90 Z1			0.25 μ m Au 5 μ m Sn Pb 1: 0.25 μ m Au 2: 5 μ m Sn Pb

Ordering information

Replace **xx** with the number of poles, e.g. 802-10-**0xx**-30-001 for a double row version with 8 pins per row becomes: 802-10-**016**-30-001

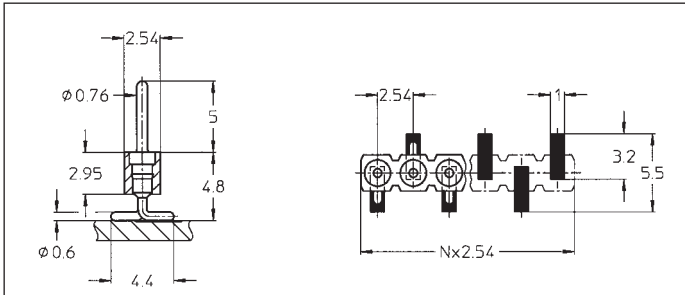

- 800-10-0xx-30-001
- 800-90-0xx-30-001
- 800-Z1-0xx-30-001

SMD pin connector: single row, perpendicular mount
Availability from: 3 to 64 contacts
Standard number of contacts 5, 6, 8, 10, 14, 16, 20, 21, 25, 30, 32, 48, 56, 60, 64

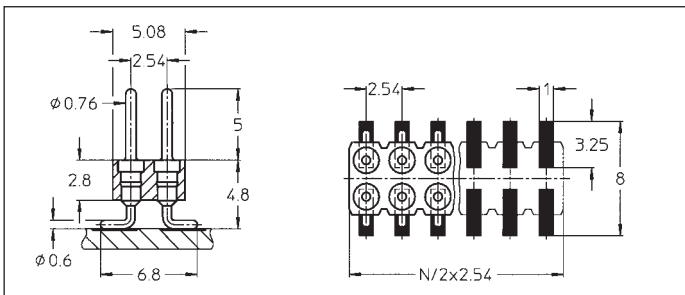

- 802-10-0xx-30-001
- 802-90-0xx-30-001
- 802-Z1-0xx-30-001

SMD pin connector: double row, perpendicular mount
Availability from: 4 to 72 contacts
Standard number of contacts 40, 44, 56, 64, 72

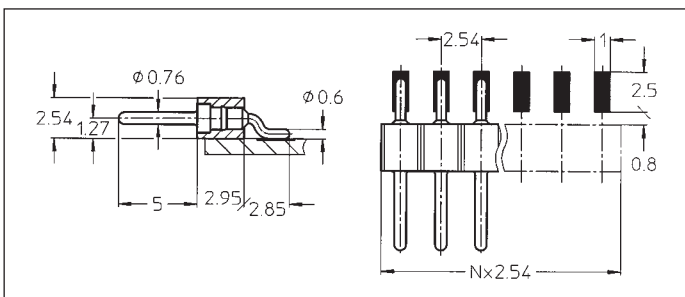

- 800-10-0xx-40-001
- 800-90-0xx-40-001
- 800-Z1-0xx-40-001

SMD pin connector: single row, parallel mount
Availability from: 2 to 64 contacts
Standard number of contacts 5, 6, 8, 10, 14, 16, 20, 21, 25, 30, 32, 48, 56, 60, 64

Series 800

PCB connectors 2.54 mm

Single row / double row

Press-fit

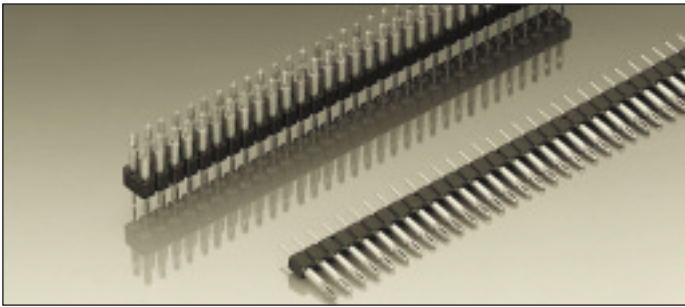

Pin connectors, press-fit

Pin connectors with screw-machined pin $\varnothing 0.76$ mm

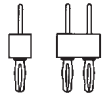

With compliant pin for solderless mount into PCB plated-thru holes $\varnothing 1$ mm +0.09/-0.06 mm



For corresponding connectors see pages 22 to 29

New version with modified eye of the needle pin

Ordering information

Replace **xxx** with the number of poles, e.g. 802-10-**xxx**-65-001 for a double row version with 8 pins per row becomes: 802-10-**016**-65-001

(Older versions 800/802-...-61/62-001 please consult)

Platings	Sleeve 	Clip 	Pin 
10 90			0.25 μ m Au 5 μ m Sn Pb

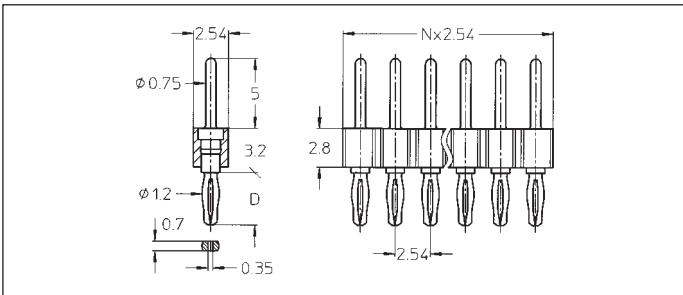

for PCB thickness 1.5 to 2.0 mm D = 2.80 mm

800-10-xxx-65-001

800-90-xxx-65-001

for PCB thickness 2.1 to 3.2 mm D = 3.80 mm

800-10-xxx-66-001

800-90-xxx-66-001

Press-fit pin connector: single row

Availability from: 1 to 64 contacts
Standard number of contacts 5, 6, 8, 10, 14, 16, 20, 21, 25, 30, 32, 48, 56, 60, 64

New version with modified eye of the needle pin

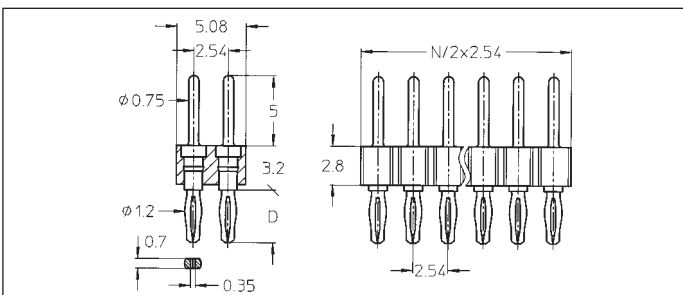

for PCB thickness 1.5 to 2.0 mm D = 2.80 mm

802-10-xxx-65-001

802-90-xxx-65-001

for PCB thickness 2.1 to 3.2 mm D = 3.80 mm

802-10-xxx-66-001

802-90-xxx-66-001

Press-fit pin connector: double row

Availability from: 4 to 72 contacts
Standard number of contacts 40, 44, 56, 64, 72

New version with modified eye of the needle pin

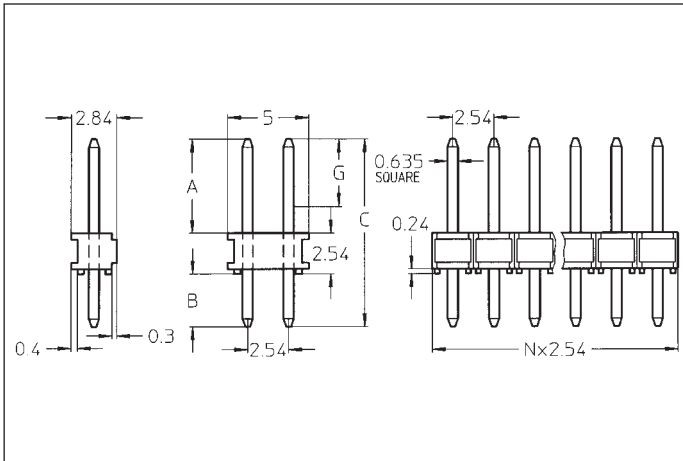





Series 890 / 892 square pin headers are cost efficient thanks to selective gold plating on pins made of copper alloy

They come with various pin lengths to suit many different applications

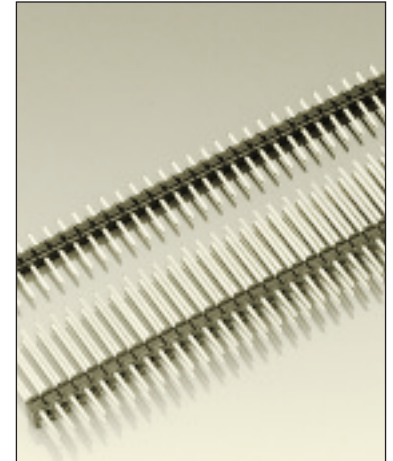
When used with series 999 female jumpers, these connectors may serve as a practical, simple means for coding purposes

For corresponding receptacles see pages 22 to 29



Platings	Sleeve 	Clip 	Pin 
19 39 90			0.25 µm Au/Sn Pb* 0.75 µm Au/Sn Pb* Sn Pb * selective

Ordering information

Replace **xxx** with required number of poles, e.g. 892-39-xxx-10-802 for a double row version with 12 pins per row becomes: 892-39-**024**-10-802

Availability:

single row: 1 to 36 contacts, standard 36 contacts
double row: 4 to 72 contacts, standard 72 contacts

Order Codes			Dimensions			
Plating 19	Plating 39 B	Plating 90	Solder side B ± 0.2	Connector side A ± 0.2	Total length C ± 0.1	Min. length of gold plating G
Single row						
890-19-xxx-10-802	890-39-xxx-10-802	890-90-xxx-10-802	2.56	5.7	10.8	4.5
890-19-xxx-10-809	890-39-xxx-10-809	890-90-xxx-10-809	2.46	8.5	13.5	7.3
890-19-xxx-10-803	890-39-xxx-10-803	890-90-xxx-10-803	2.96	5.8	11.3	4.6
890-19-xxx-10-000	890-39-xxx-10-000	890-90-xxx-10-000	2.96	7.0	12.5	5.8
890-19-xxx-10-800	890-39-xxx-10-800	890-90-xxx-10-800	3.26	6.7	12.5	5.5
890-19-xxx-10-804	890-39-xxx-10-804	890-90-xxx-10-804	3.46	5.8	11.8	4.6
890-19-xxx-10-811	890-39-xxx-10-811	890-90-xxx-10-811	3.06	15.4	21.0	14.2
890-19-xxx-10-805	890-39-xxx-10-805	890-90-xxx-10-805	4.96	6.0	13.5	4.8
890-19-xxx-10-807	890-39-xxx-10-807	890-90-xxx-10-807	10.06	5.7	18.3	4.5
890-19-xxx-10-808	890-39-xxx-10-808	890-90-xxx-10-808	12.76	5.7	21.0	4.5
Double row						
892-19-xxx-10-802	892-39-xxx-10-802	892-90-xxx-10-802	2.56	5.7	10.8	4.5
892-19-xxx-10-809	892-39-xxx-10-809	892-90-xxx-10-809	2.46	8.5	13.5	7.3
892-19-xxx-10-803	892-39-xxx-10-803	892-90-xxx-10-803	2.96	5.8	11.3	4.6
892-19-xxx-10-000	892-39-xxx-10-000	892-90-xxx-10-000	2.96	7.0	12.5	5.8
892-19-xxx-10-800	892-39-xxx-10-800	892-90-xxx-10-800	3.26	6.7	12.5	5.5
892-19-xxx-10-804	892-39-xxx-10-804	892-90-xxx-10-804	3.46	5.8	11.8	4.6
892-19-xxx-10-811	892-39-xxx-10-811	892-90-xxx-10-811	3.06	15.4	21.0	14.2
892-19-xxx-10-805	892-39-xxx-10-805	892-90-xxx-10-805	4.96	6.0	13.5	4.8
892-19-xxx-10-807	892-39-xxx-10-807	892-90-xxx-10-807	10.06	5.7	18.3	4.5
892-19-xxx-10-808	892-39-xxx-10-808	892-90-xxx-10-808	12.76	5.7	21.0	4.5

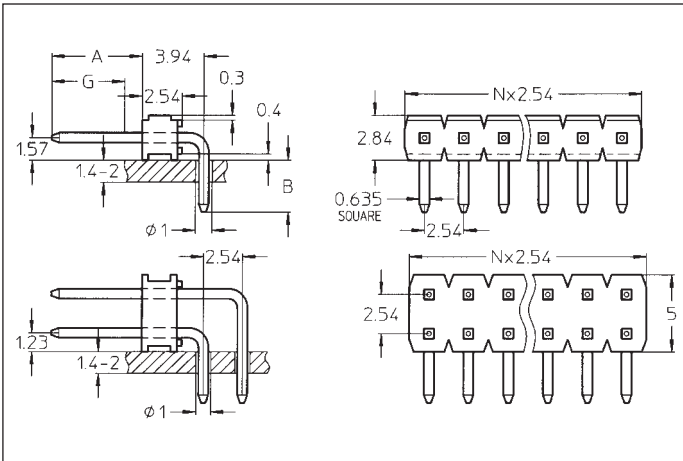





Series 890/892 square pin headers are cost efficient thanks to selective gold plating on pins made of copper alloy

They come with various pin lengths to suit many different applications

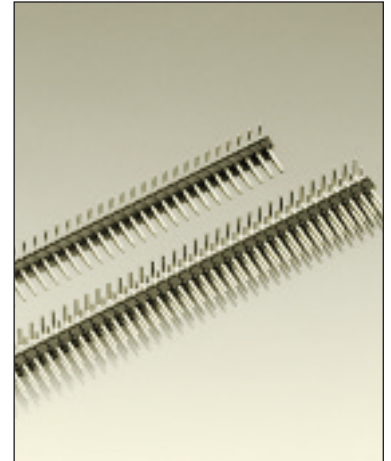
When used with series 999 female jumpers, these connectors may serve as a practical, simple means for coding purposes

For corresponding receptacles see pages 22 to 29



Platings	Sleeve 	Clip 	Pin 
19 39 90			0.25 μm Au/Sn Pb* 0.75 μm Au/Sn Pb* Sn Pb * selective

Ordering information

Replace **xxx** with required number of poles, e.g. 892-39-xxx-20-902 for a double row version with 12 pins per row becomes: 892-39-**024**-20-902

Availability:

single row: 1 to 36 contacts, standard 36 contacts
double row: 4 to 72 contacts, standard 72 contacts

Order Codes			Dimensions		
Plating 19	Plating 39 B	Plating 90	Solder side B ± 0.2	Connector side A ± 0.2	Min. length of gold plating G
Single row					
890-19-xxx-20-902	890-39-xxx-20-902	890-90-xxx-20-902	2.5	5.7	4.5
890-19-xxx-20-000	890-39-xxx-20-000	890-90-xxx-20-000	2.9	7.0	5.8
890-19-xxx-20-901	890-39-xxx-20-901	890-90-xxx-20-901	3.2	6.7	5.5
890-19-xxx-20-903	890-39-xxx-20-903	890-90-xxx-20-903	3.4	5.8	4.6
890-19-xxx-20-904	890-39-xxx-20-904	890-90-xxx-20-904	5.1	5.7	4.5
Double row					
892-19-xxx-20-902	892-39-xxx-20-902	892-90-xxx-20-902	2.5	5.7	4.5
892-19-xxx-20-000	892-39-xxx-20-000	892-90-xxx-20-000	2.9	7.0	5.8
892-19-xxx-20-901	892-39-xxx-20-901	892-90-xxx-20-901	3.2	6.7	5.5
892-19-xxx-20-903	892-39-xxx-20-903	892-90-xxx-20-903	3.4	5.8	4.6

For other pin and solder tail lengths, triple row headers, double body board spacer (Sandwich) headers and SMT or press-fit terminations please consult.

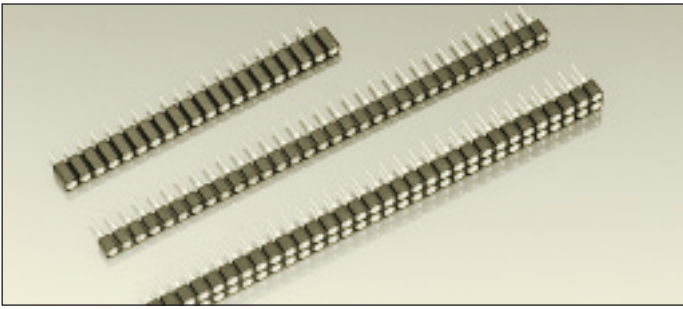



Receptacles, solder tail

Accept pins \varnothing 0.40–0.56 mm

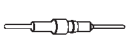

For corresponding pin connectors see pages 43 to 46

Platings	Sleeve 	Clip 	Pin 
13	0.25 μ m Au	0.75 μ m Au	
91	5 μ m Sn Pb	0.25 μ m Au	
93	5 μ m Sn Pb	0.75 μ m Au	
97	5 μ m Sn Pb	Goldflash	
99	5 μ m Sn Pb	5 μ m Sn Pb	

Ordering information

Replace **xx** with the number of poles, e.g. 410-91-2**xx**-41-001 for a double row version with 8 pins per row becomes:
410-91-2**16**-41-001

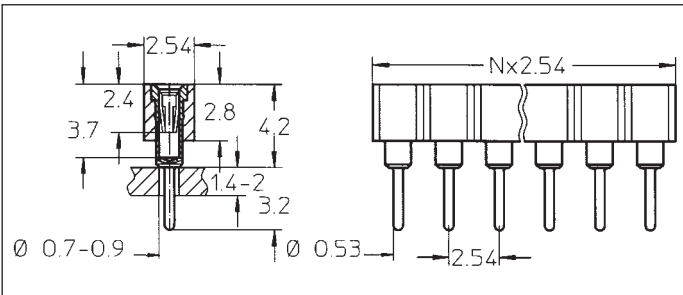

- 310-13-1xx-41-001 **B**
- 310-91-1xx-41-001
- 310-93-1xx-41-001
- 310-97-1xx-41-001
- 310-99-1xx-41-001

Straight receptacle: solder tail, single row

Availability from: 1 to 64 contacts
Standard number of contacts 5, 6, 8, 10, 14, 16, 20, 21, 25, 30, 32, 48, 56, 60, 64

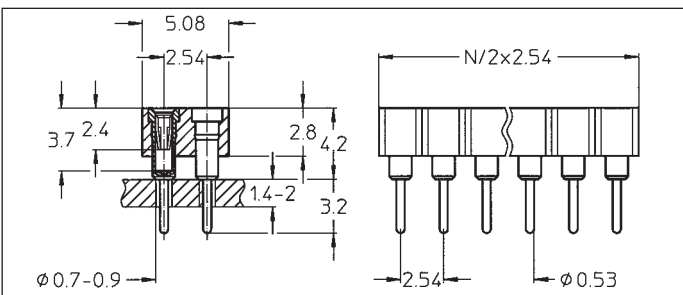

- 410-13-2xx-41-001 **B**
- 410-91-2xx-41-001
- 410-93-2xx-41-001
- 410-97-2xx-41-001
- 410-99-2xx-41-001

Straight receptacle: solder tail, double row

Availability from: 4 to 72 contacts
Standard number of contacts 40, 44, 56, 64, 72

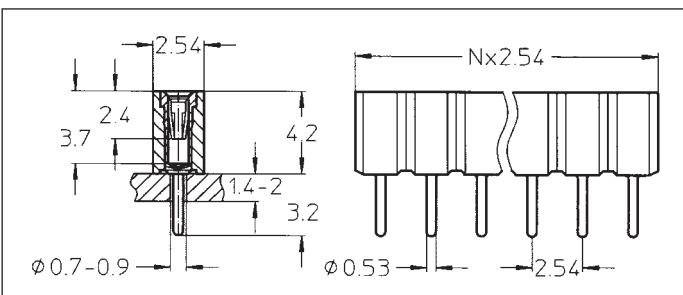

- 310-91-1xx-01-640
- 310-93-1xx-01-640
- 310-97-1xx-01-640
- 310-99-1xx-01-640

Straight receptacle: solder tail, single row, with standoff

Availability from: 1 to 32 contacts
Standard number of contacts 14, 20, 32

Option
On request double and triple row

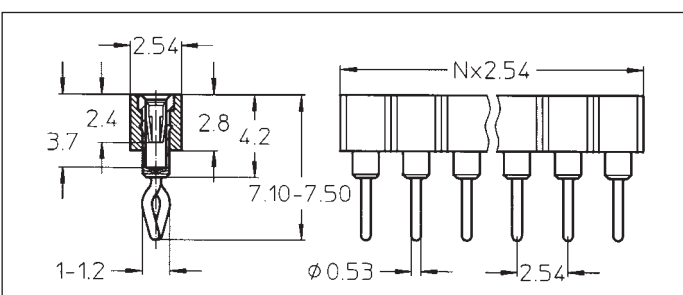

- 310-91-1xx-01-666
- 310-93-1xx-01-666
- 310-97-1xx-01-666
- 310-99-1xx-01-666

Straight receptacle: with clinched (right/left) solder tails, single row

Availability from: 3 to 64 contacts
Standard number of contacts 5, 6, 8, 10, 14, 16, 20, 21, 25, 30, 32, 48, 56, 60, 64



Receptacles, solder tail



Accept pins \varnothing 0.40–0.56 mm



For corresponding pin connectors see pages 43 to 46

Ordering information

Replace **xx** with the number of poles, e.g. 411-91-2**xx**-41-001 for a double row version with 8 pins per row becomes: 411-91-2**16**-41-001

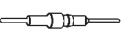
Platings	Sleeve 	Clip 	Pin 
91	5 μ m Sn Pb	0.25 μ m Au	
93	5 μ m Sn Pb	0.75 μ m Au	
97	5 μ m Sn Pb	Goldflash	
99	5 μ m Sn Pb	5 μ m Sn Pb	

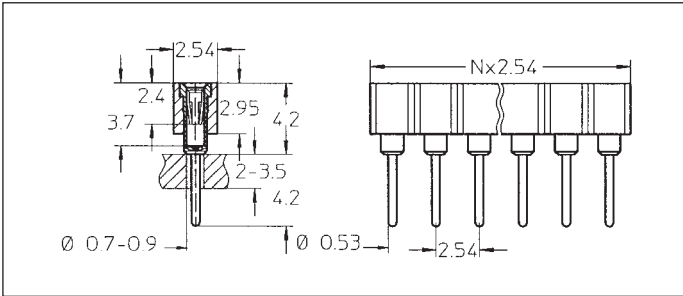

- 311-91-1xx-41-001 **B**
- 311-93-1xx-41-001 **B**
- 311-99-1xx-41-001 **B**

Straight receptacle: solder tail, long, single row
 Availability from: 1 to 64 contacts
 Standard number of contacts 5, 6, 8, 10, 14, 16, 20, 21, 25, 30, 32, 48, 56, 60, 64

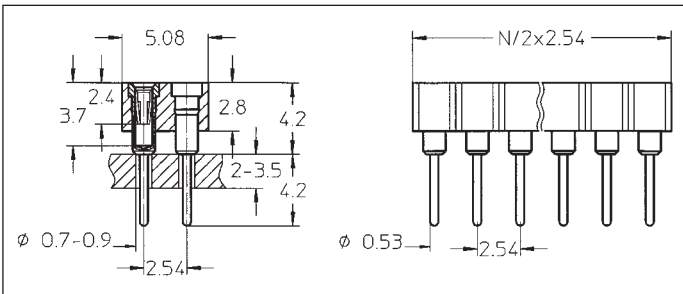

- 411-91-2xx-41-001 **B**
- 411-93-2xx-41-001 **B**
- 411-99-2xx-41-001 **B**

Straight receptacle: solder tail, long, double row
 Availability from: 4 to 72 contacts
 Standard number of contacts 40, 44, 56, 64, 72

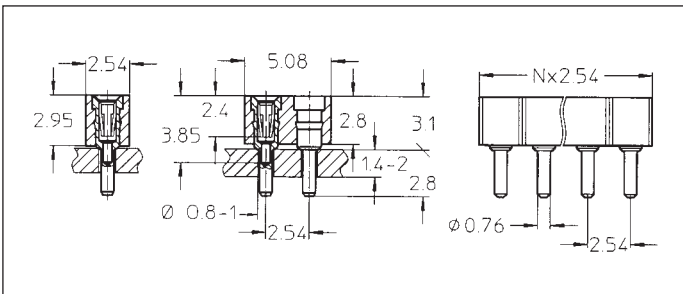

- Very low profile:
- 315-91-1xx-41-001
 - 315-93-1xx-41-001
 - 315-99-1xx-41-001
 - 415-91-2xx-41-001
 - 415-93-2xx-41-001
 - 415-99-2xx-41-001

Straight receptacle: solder tail, single row, low profile
 Availability from: 1 to 64 contacts
 Standard number of contacts 5, 6, 8, 10, 14, 16, 20, 21, 25, 30, 32, 48, 56, 60, 64
 Straight receptacle: solder tail, double row, low profile
 Availability from: 4 to 72 contacts
 Standard number of contacts 40, 44, 56, 64, 72

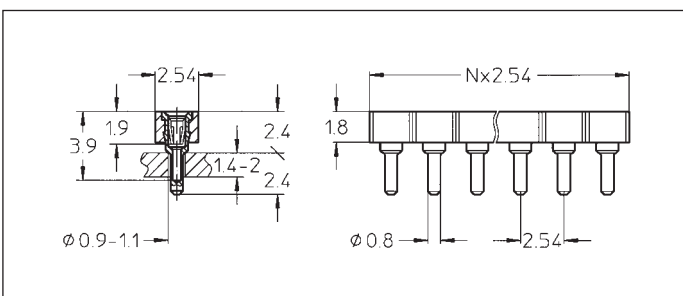

- Ultra low profile:
- 315-91-1xx-41-003
 - 315-93-1xx-41-003
 - 315-97-1xx-41-003
 - 315-99-1xx-41-003

Straight receptacle: solder tail, single row, ultra low profile
 Availability from: 1 to 64 contacts
 Standard number of contacts 20, 56 and 64
 Ultra low version not available as double row

Series 316 / 416

PCB connectors 2.54 mm
Single row / double row
Solder tail

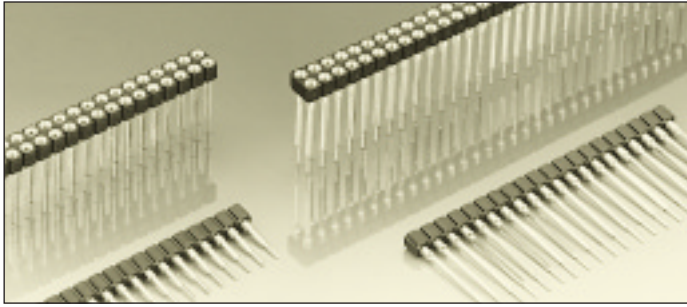



Interconnect receptacles, solder tail

Receptacles accept pins \varnothing 0.40–0.56 mm

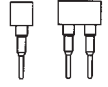
For corresponding pin connectors see pages 43 to 46



Platings	Sleeve 	Clip 	Pin 
93	5 μ m Sn Pb	0.75 μ m Au	

Ordering information

Replace **xx** with the number of poles, e.g. 416-93-2**xx**-41-006 for a double row version with 8 pins per row becomes: 416-93-2**16**-41-006

Option:

On request triple row

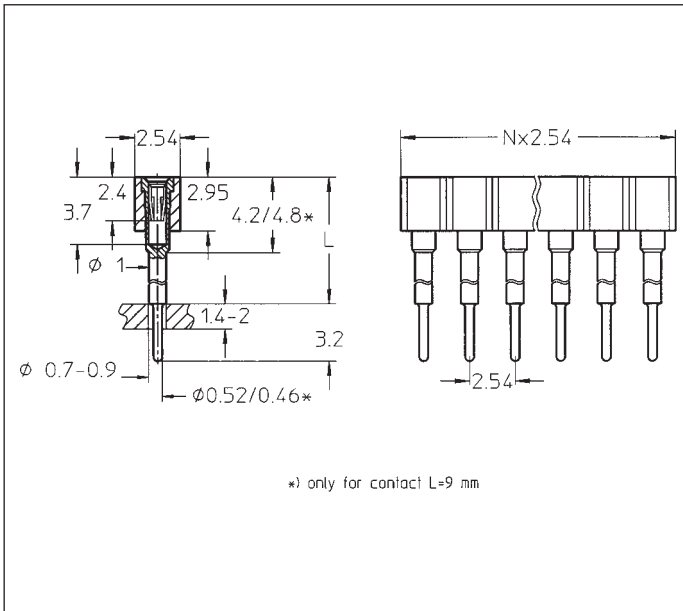

L =	
6 mm	316-93-1xx-41-006
8 mm	316-93-1xx-41-003
9 mm	316-93-1xx-41-012
10 mm	316-93-1xx-41-007
12 mm	316-93-1xx-41-008
13 mm	316-93-1xx-41-009
15 mm	316-93-1xx-41-001
18 mm	316-93-1xx-41-011
22 mm	316-93-1xx-41-004
33 mm	316-93-1xx-41-013

Interconnect receptacle: solder tail, single row

Availability from: 1 to 64 contacts
Standard number of contacts 5, 6, 8, 10, 14, 16, 20, 21, 25, 30, 32, 48, 56, 60, and 64

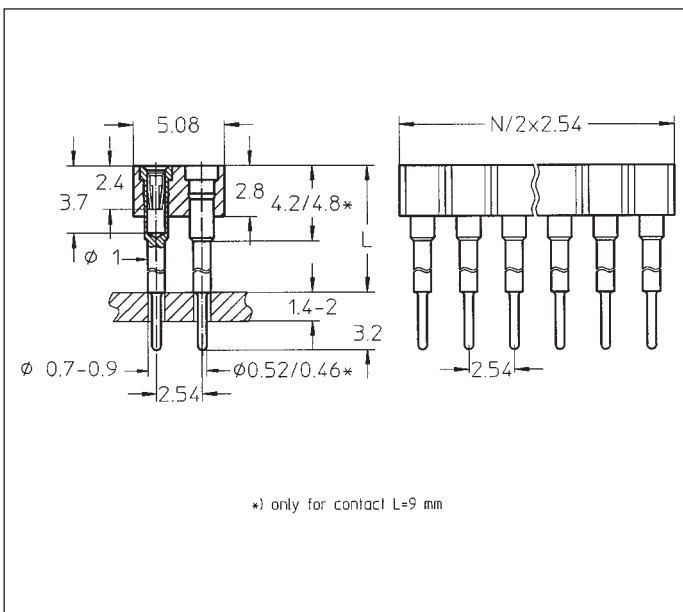

L =	
6 mm	416-93-2xx-41-006
8 mm	416-93-2xx-41-003
9 mm	416-93-2xx-41-012
10 mm	416-93-2xx-41-007
12 mm	416-93-2xx-41-008
13 mm	416-93-2xx-41-009
15 mm	416-93-2xx-41-001
18 mm	416-93-2xx-41-011
22 mm	416-93-2xx-41-004
33 mm	416-93-2xx-41-013

Interconnect receptacle: solder tail, double row

Availability from: 4 to 72 contacts
Standard number of contacts 40, 44, 56, 64 and 72

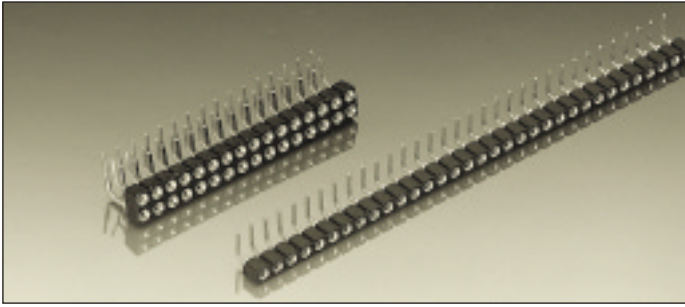



Right angle receptacles, solder tail

Receptacles accept pins
Ø 0.40–0.56 mm



For corresponding connectors see pages 43 to 46

Platings	Sleeve 	Clip 	Pin 
91	5 µm Sn Pb	0,25 µm Au	
93	5 µm Sn Pb	0,75 µm Au	

Ordering information

Replace **xx** with the number of poles, e.g. 499-93-2**xx**-10-003
for a double row version with 8 pins per row becomes:
499-93-2**16**-10-003

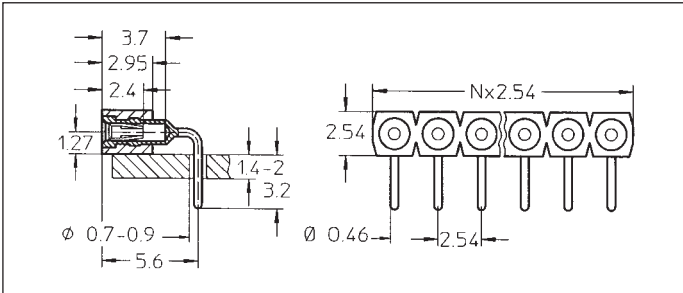

399-91-1xx-10-003
399-93-1xx-10-003

Right angle receptacle: single row

Availability from: 1 to 64 contacts
Standard number of contacts 5, 6, 8, 10, 14, 16, 20, 21, 25, 30, 32, 48, 56, 60, 64

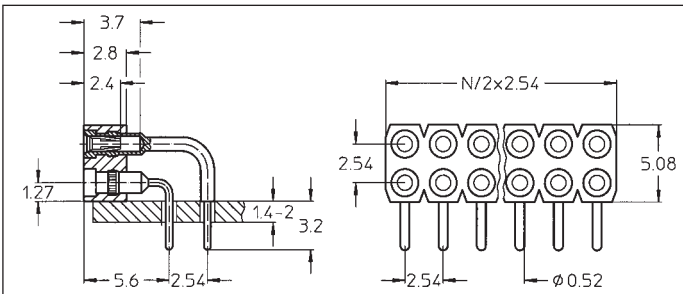

499-91-2xx-10-003
499-93-2xx-10-003

Right angle receptacle: double row

Availability from: 4 to 72 contacts
Standard number of contacts 40, 44, 56, 64, 72

Series 310 / 410

PCB connectors 2.54 mm
Single row / double row
Surface mount

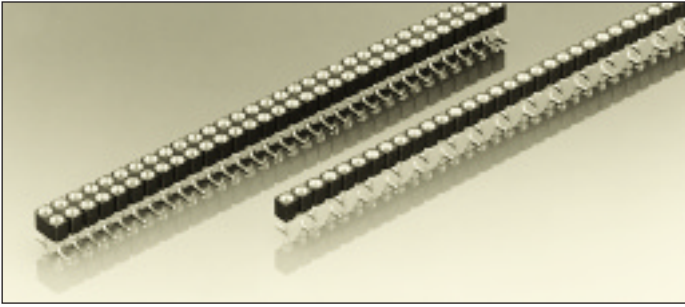



Receptacles, surface mount

Accept pins \varnothing 0.40–0.56 mm

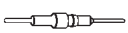

For corresponding pin connectors see pages 43 to 46

Platings	Sleeve 	Clip 	Pin 
91	5 μ m Sn Pb	0.25 μ m Au	
93	5 μ m Sn Pb	0.75 μ m Au	
97	5 μ m Sn Pb	Goldflash	
99	5 μ m Sn Pb	5 μ m Sn Pb	

Ordering information

Replace **xx** with the number of poles, e.g. 410-91-2**xx**-41-105 for a double row version with 8 pins per row becomes: 410-91-2**16**-41-105

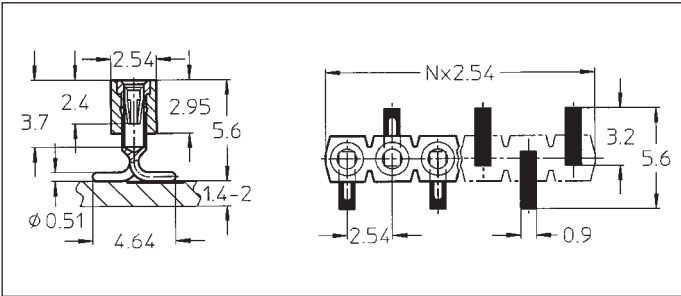

- 310-91-1xx-41-105
- 310-93-1xx-41-105
- 310-97-1xx-41-105
- 310-99-1xx-41-105

SMD receptacle: single row, perpendicular mount

Availability from: 3 to 64 contacts
Standard number of contacts 5, 6, 8, 10, 14, 16, 20, 21, 25, 30, 32, 48, 56, 60, 64

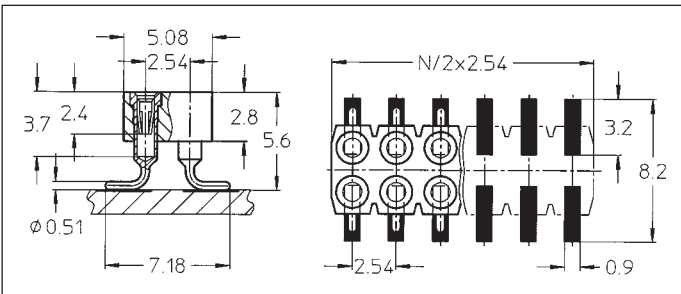

- 410-91-2xx-41-105
- 410-93-2xx-41-105
- 410-97-2xx-41-105
- 410-99-2xx-41-105

SMD receptacle: double row, perpendicular mount

Availability from: 4 to 72 contacts
Standard number of contacts 40, 44, 56, 64, 72

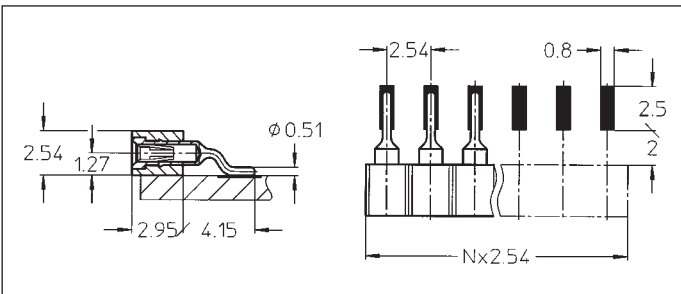

- 310-91-1xx-41-205
- 310-93-1xx-41-205
- 310-97-1xx-41-205
- 310-99-1xx-41-205

SMD receptacle: single row, parallel mount

Availability from: 1 to 64 contacts
Standard number of contacts 5, 6, 8, 10, 14, 16, 20, 21, 25, 30, 32, 48, 56, 60, 64

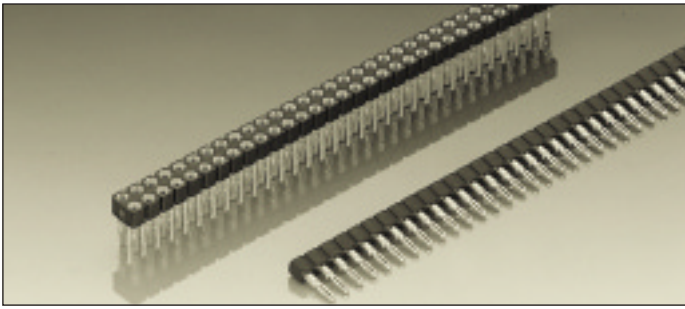

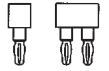

Receptacles, press-fit

For solderless mount into PCB, plated-thru holes, for pins \varnothing 0.40–0.56 mm



For corresponding pin connectors see pages 43 to 46

New version with modified eye of the needle pin

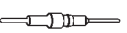
Platings	Sleeve 	Clip 	Pin 
91	5 μ m Sn Pb	0.25 μ m Au	
93	5 μ m Sn Pb	0.75 μ m Au	
99	5 μ m Sn Pb	5 μ m Sn Pb	

Ordering information

Replace **xx** with the number of poles, e.g. 346-93-1**xx**-41-035 for a single row version with 8 pins becomes: 346-93-**108**-41-035

(Older versions 346/446-...-41-012/013/019 please consult)

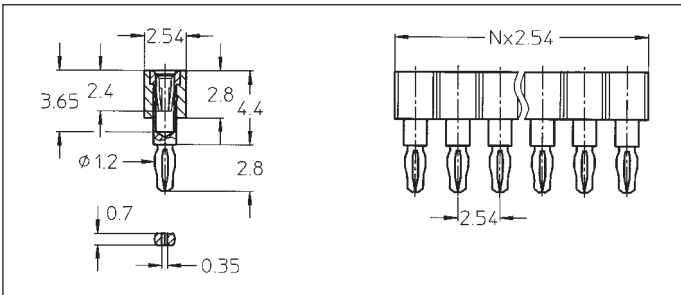

346-91-1xx-41-036
346-93-1xx-41-036
346-99-1xx-41-036

Press-fit receptacle connector:
single row, compliant pin
for plated-thru hole
 \varnothing 1 (+0.09/-0.06) mm

Availability from: 1 to 64 contacts
Standard number of contacts 5, 6, 8, 10, 14, 16, 20, 21, 25, 30, 32, 48, 56, 60, 64

For PCB thickness 1.5 to 2.0 mm

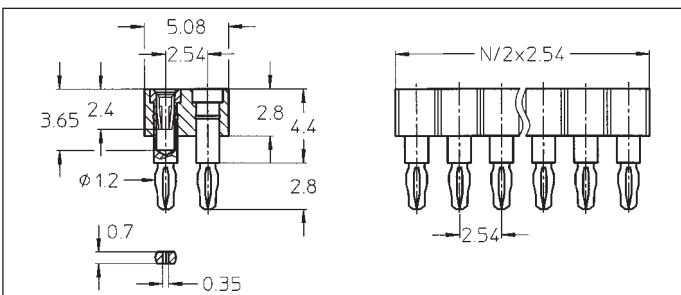

446-91-2xx-41-036
446-93-2xx-41-036
446-99-2xx-41-036

Press-fit receptacle connector:
double row, compliant pin
for plated-thru hole
 \varnothing 1 (+0.09/-0.06) mm

Availability from: 4 to 72 contacts
Standard number of contacts 40, 44, 56, 64, 72

For PCB thickness 1.5 to 2.0 mm

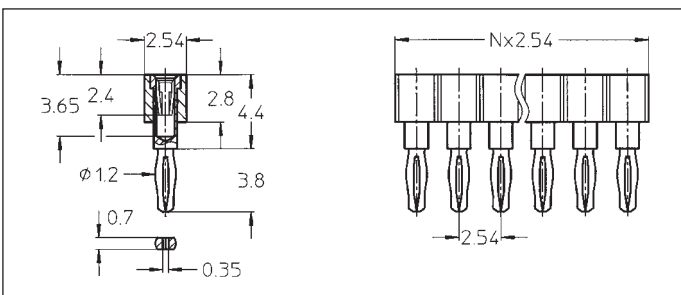

346-91-1xx-41-035
346-93-1xx-41-035
346-99-1xx-41-035

Press-fit receptacle connector:
single row, compliant pin
for plated-thru hole
 \varnothing 1 (+0.09/-0.06) mm

Availability from: 1 to 64 contacts
Standard number of contacts 5, 6, 8, 10, 14, 16, 20, 21, 25, 30, 32, 48, 56, 60, 64

For PCB thickness 2.1 to 3.2 mm

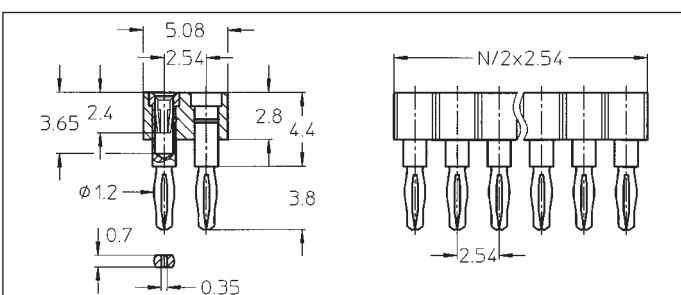

446-91-2xx-41-035
446-93-2xx-41-035
446-99-2xx-41-035

Press-fit receptacle connector:
double row, compliant pin
for plated-thru hole
 \varnothing 1 (+0.09/-0.06) mm

Availability from: 4 to 72 contacts
Standard number of contacts 40, 44, 56, 64, 72

For PCB thickness 2.1 to 3.2 mm

Series 321–326 / 421–426

PCB connectors 2.54 mm

Single row / double row / wire-wrap

1/2/3/4 level / wire-wrap solder tail

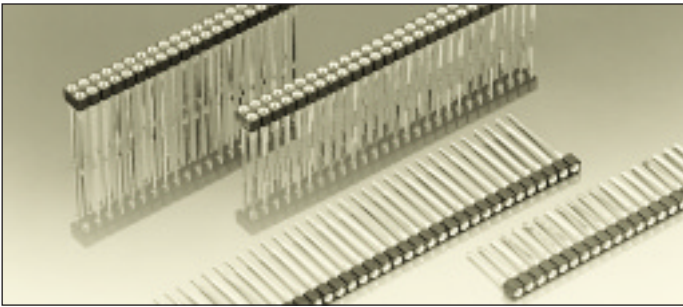



Receptacles with wire-wrap posts Interconnect receptacles with wire-wrap – solder tail combination

Accept pins \varnothing 0.40–0.56 mm

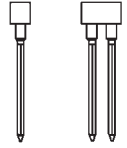
For corresponding pin connectors see pages 43 to 46

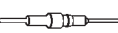

Platings	Sleeve 	Clip 	Pin 
13	0.25 μ m Au	0.75 μ m Au	
91	5 μ m Sn Pb	0.25 μ m Au	
93	5 μ m Sn Pb	0.75 μ m Au	
99	5 μ m Sn Pb	5 μ m Pb	

Ordering information

Replace **xx** with required number of poles, e.g.
423-91-**2xx**-41-001 for a double row version with 8 poles per row becomes:
423-91-**216**-41-001

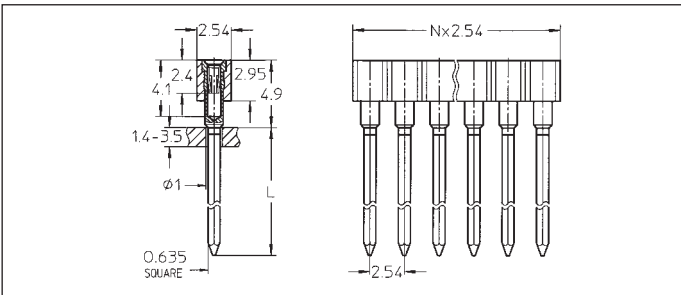

	L =
321-93-1xx-41-001 B	6.6
322-**-1xx-41-001	9.4
323-**-1xx-41-001	12.95
324-93-1xx-41-002 B	16.0

Please note: ** = all platings available; 93 = this plating only.

Wire-wrap receptacle, 1, 2, 3 and 4 level: single row

Availability from: 1 to 64 contacts
Standard number of contacts 5, 6, 8, 10, 14, 16, 20, 21, 25, 30, 32, 48, 56, 60, 64

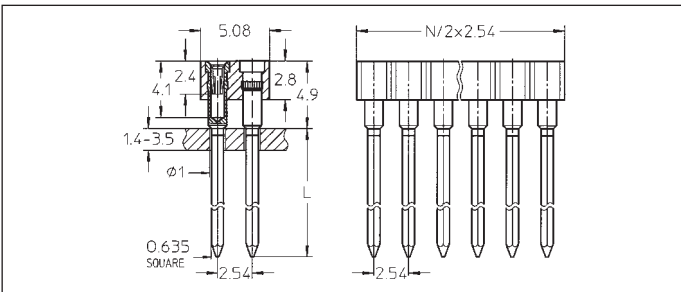

	L =
421-93-2xx-41-001 B	6.6
422-**-2xx-41-001	9.4
423-**-2xx-41-001	12.95
424-93-2xx-41-002 B	16.0

Please note: ** = all platings available; 93 = this plating only.

Wire-wrap receptacle, 1, 2, 3 and 4 level: double row

Availability from: 4 to 72 contacts
Standard number of contacts 40, 44, 56, 64, 72

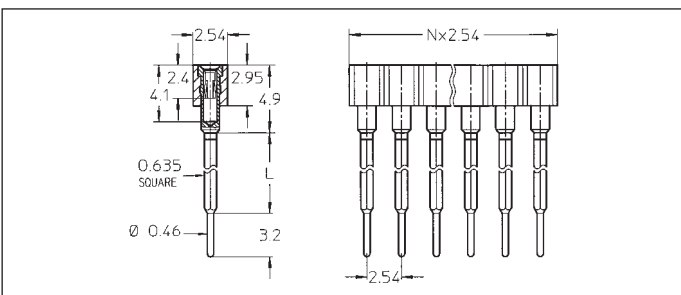

326-93-1xx-41-001	L = 5.9
326-93-1xx-41-002	L = 8.9
326-93-1xx-41-003	L = 11.9

Interconnect receptacle with wire-wrap – solder tail combination, single row

Availability from: 1 to 64 contacts
Standard number of contacts 5, 6, 8, 10, 14, 16, 20, 21, 25, 30, 32, 48, 56, 60, 64

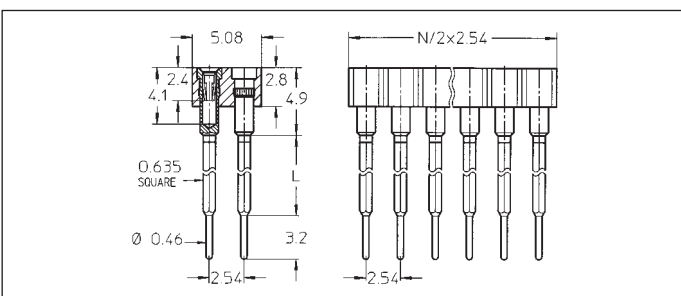

426-93-2xx-41-001	L = 5.9
426-93-2xx-41-002	L = 8.9
426-93-2xx-41-003	L = 11.9

Interconnect receptacle with wire-wrap – solder tail combination, double row

Availability from: 4 to 72 contacts
Standard number of contacts 40, 44, 56, 64, 72

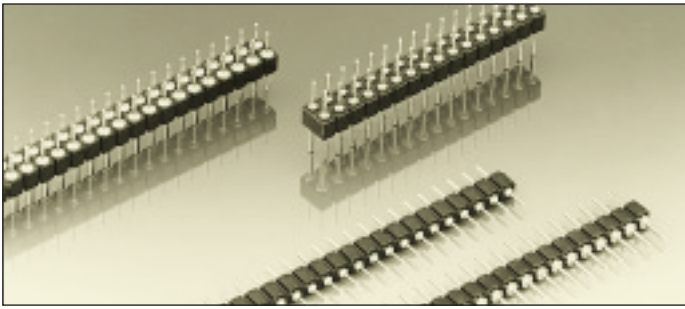

Pin connectors, solder tail

With screw-machined pins \varnothing 0.47 mm

For corresponding receptacles see pages 36 to 42 and 47, 48

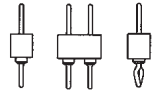



New:

Pin connectors with selective plated precision screw machined pin, plating code Z1.

Connecting side 1: gold plated
soldering/PCB side 2: tin plated

Ordering information

Replace **xx** with the number of poles, e.g. 450-10-2**xx**-00-001 for a double row version with 8 pins per row becomes: 450-10-2**16**-00-001

Platings	Sleeve 	Clip 	Pin 
10 90 Z1			0.25 μ m Au 5 μ m Sn Pb 1: 0.25 μ m Au 2: 5 μ m Sn Pb

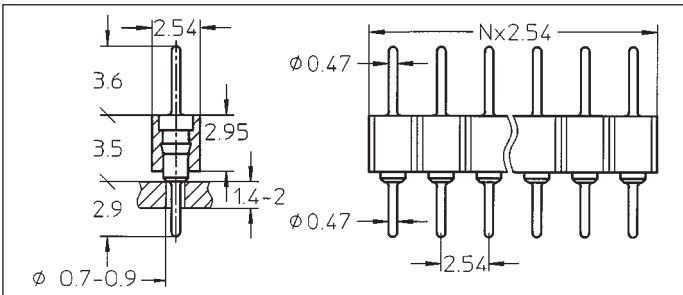

- 350-10-1xx-00-006
- 350-90-1xx-00-006
- 350-Z1-1xx-00-006

Straight pin connector: solder tail, single row

Availability from: 1 to 64 contacts
Standard number of contacts 5, 6, 8, 10, 14, 16, 20, 21, 25, 30, 32, 48, 56, 60, 64

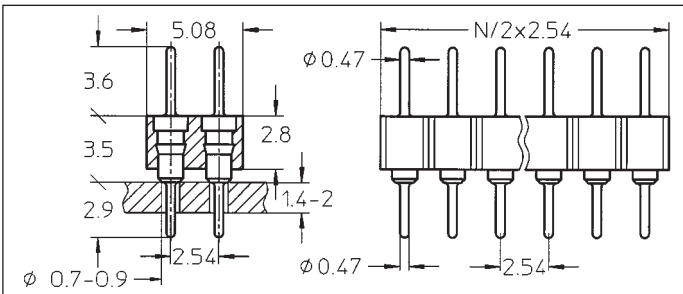

- 450-10-2xx-00-006
- 450-90-2xx-00-006
- 450-Z1-2xx-00-006

Straight pin connector: solder tail, double row

Availability from: 4 to 72 contacts
Standard number of contacts 40, 44, 56, 64, 72

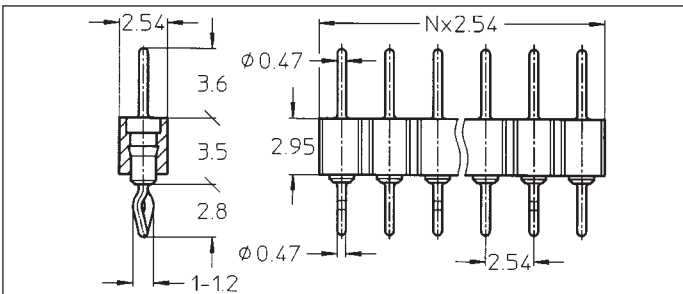

- 350-10-1xx-01-666
- 350-90-1xx-01-666
- 350-Z1-1xx-01-666

Straight pin connector with clinched (right/left) solder tails, single row

Availability from: 3 to 64 contacts
Standard number of contacts 5, 6, 8, 10, 14, 16, 20, 21, 25, 30, 32, 48, 56, 60, 64

Series 350 / 351 / 450 / 451

PCB connectors 2.54 mm

Single row / double row

Solder tail

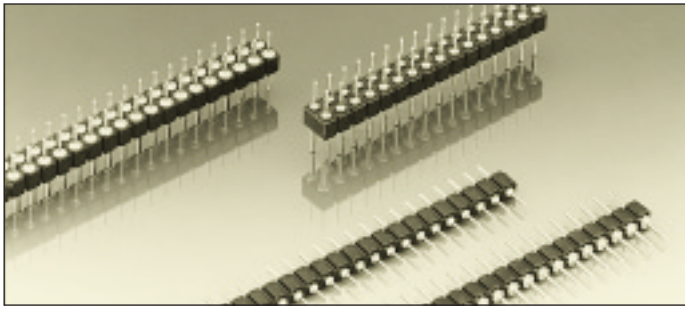



Pin connectors, solder tail

With screw-machined pins \varnothing 0.47 mm

For corresponding receptacles see pages 36 to 42 and 47, 48

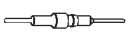

Platings	Sleeve 	Clip 	Pin 
10 90			0.25 μ m Au 5 μ m Sn Pb

Ordering information

Replace **xx** with the number of poles, e.g. 450-10-2**xx**-00-001 for a double row version with 8 pins per row becomes: 450-10-2**16**-00-001

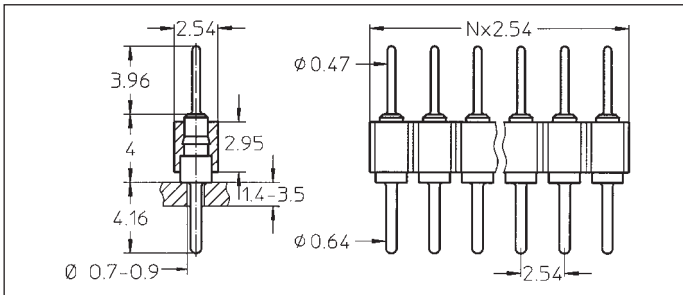

350-10-1xx-00-001
350-90-1xx-00-001

Straight pin connector: solder tail, single row

Availability from: 1 to 64 contacts
Standard number of contacts 5, 6, 8, 10, 14, 16, 20, 21, 25, 30, 32, 48, 56, 60, 64

Note:
For new designs refer to 006 version

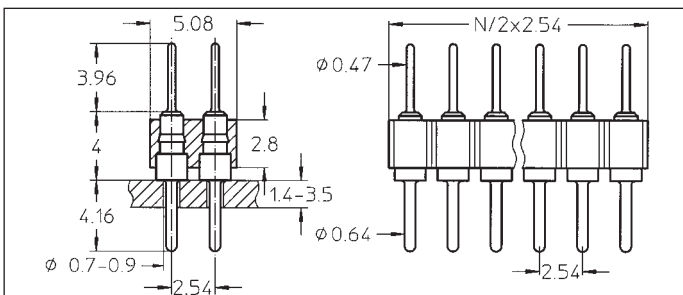

450-10-2xx-00-001
450-90-2xx-00-001

Straight pin connector: solder tail, double row

Availability from: 4 to 72 contacts
Standard number of contacts 40, 44, 56, 64, 72

Note:
For new designs refer to 006 version

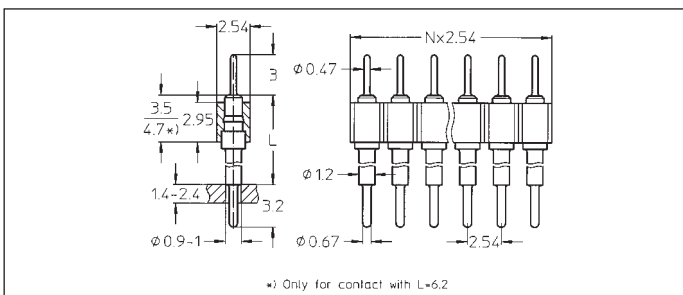

	L =
351-10-1xx-00-003	6.2 mm
351-90-1xx-00-003	
351-10-1xx-00-004	8.4 mm
351-90-1xx-00-004	
351-10-1xx-00-005	15.3 mm
351-90-1xx-00-005	
351-10-1xx-00-016	21.2 mm
351-90-1xx-00-016	
351-10-1xx-00-017	27.4 mm
351-90-1xx-00-017	

Straight interconnect pin connector solder tail, single row

Availability from: 1 to 64 contacts
Standard number of contacts 5, 6, 8, 10, 14, 16, 20, 21, 25, 30, 32, 48, 56, 60, 64

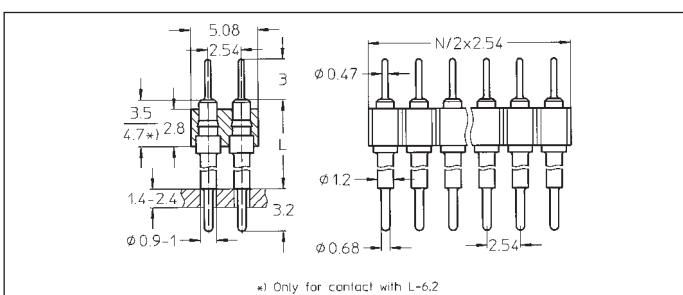

	L =
451-10-2xx-00-003	6.2 mm
451-90-2xx-00-003	
451-10-2xx-00-004	8.4 mm
451-90-2xx-00-004	
451-10-2xx-00-005	15.3 mm
451-90-2xx-00-005	
451-10-2xx-00-016	21.2 mm
451-90-2xx-00-016	
451-10-2xx-00-017	27.4 mm
451-90-2xx-00-017	

Straight interconnect pin connector solder tail, double row

Availability from: 4 to 72 contacts
Standard number of contacts 40, 44, 56, 64, 72

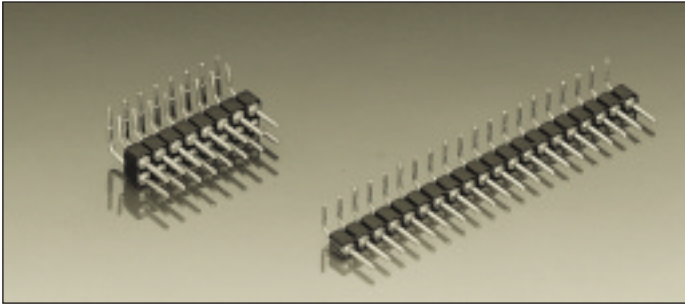

Right angle pin connectors, solder tail

Pin connectors with pins \varnothing 0.47 mm

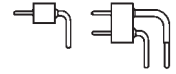



For corresponding connectors see pages 36 to 42 and 47, 48

New:

Pin connectors with selective plated precision screw machined pin, plating code Z1.

Connecting side 1: gold plated
soldering/PCB side 2: tin plated

Platings	Sleeve 	Clip 	Pin 
10 90 Z1			0,25 μ m Au 5 μ m Sn Pb 1: 0.25 μ m Au 2: 5 μ m Sn Pb

Ordering information

Replace **xx** with the number of poles, e.g. 499-93-**2xx**-10-009
for a double row version with 8 pins per row becomes:
499-93-**216**-10-009

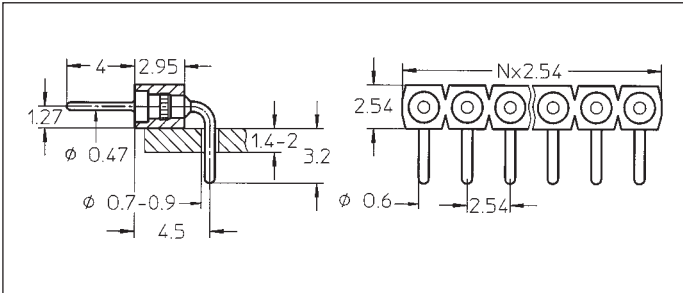

- 399-10-1xx-10-009
- 399-90-1xx-10-009
- 399-Z1-1xx-10-009

Right angle pin connector: single row
Availability from: 1 to 64 contacts
Standard number of contacts 5, 6, 8, 10, 14, 16, 20, 21, 25, 30, 32, 48, 56, 60, 64

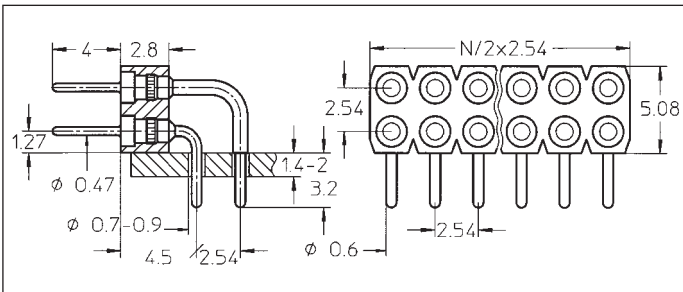

- 499-10-2xx-10-009
- 499-90-2xx-10-009
- 499-Z1-2xx-10-009

Right angle pin connector: double row
Availability from: 4 to 72 contacts
Standard number of contacts 40, 44, 56, 64, 72

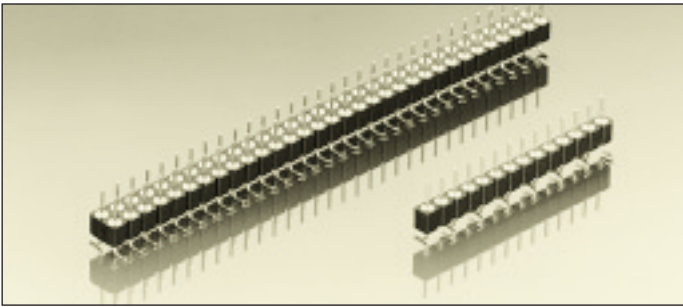

Pin connectors, surface mount

With screw machined pins $\varnothing 0.47$ mm

For corresponding receptacles see pages 36 to 42 and 47, 48

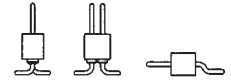



New:

Pin connectors with selective plated precision screw machined pin, plating code Z1.

Connecting side 1: gold plated
soldering/PCB side 2: tin plated

Ordering information

Replace **xx** with the number of poles, e.g. 350-10-1**xx**-00-106 for a single row version with 16 contacts becomes: 350-10-1**16**-00-106

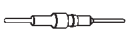
Platings	Sleeve 	Clip 	Pin 
10 90 Z1			0.25 μ m Au 5 μ m Sn Pb 1: 0.25 μ m Au 2: 5 μ m Sn Pb

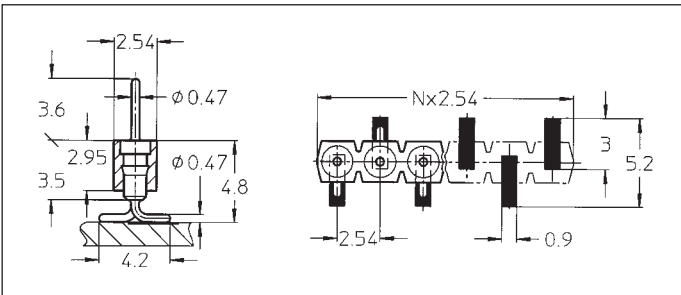

- 350-10-1xx-00-106
- 350-90-1xx-00-106
- 350-Z1-1xx-00-106

SMD pin connector: single row, perpendicular mount

Availability from: 3 to 64 contacts
Standard number of contacts 5, 6, 8, 10, 14, 16, 20, 21, 25, 30, 32, 48, 56, 60, 64

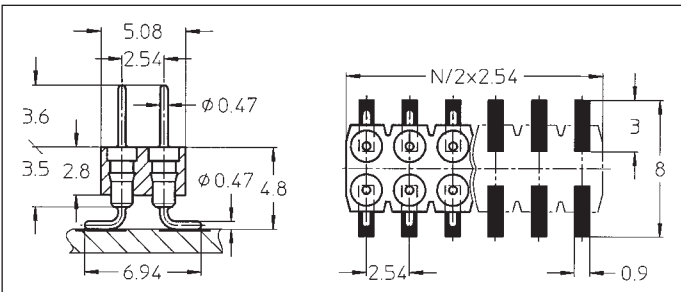

- 450-10-2xx-00-106
- 450-90-2xx-00-106
- 450-Z1-2xx-00-106

SMD pin connector: double row, perpendicular mount

Availability from: 4 to 72 contacts
Standard number of contacts 40, 44, 56, 64, 72

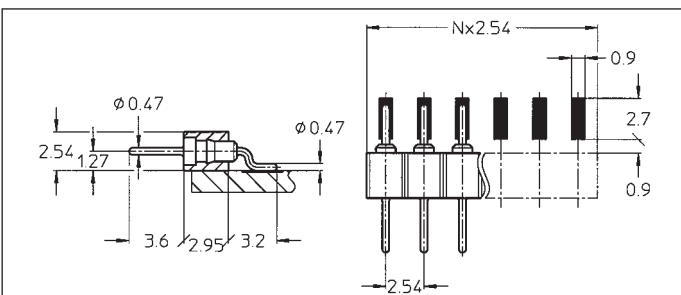

- 350-10-1xx-00-206
- 350-90-1xx-00-206
- 350-Z1-1xx-00-206

SMD pin connector: single row, parallel mount

Availability from: 1 to 64 contacts
Standard number of contacts 5, 6, 8, 10, 14, 16, 20, 21, 25, 30, 32, 48, 56, 60, 64

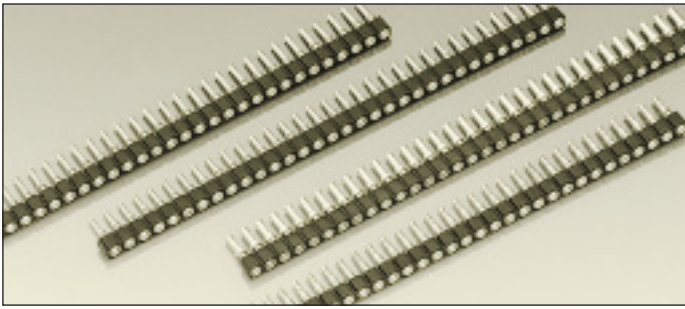

PCB "Zero profile" receptacles

Accept pins \varnothing 0.40–0.56 mm



Single receptacle contacts for solder mount into PCB, supplied on disposable carriers.



For corresponding pin connectors see pages 43 to 46

Ordering information

Replace **xx** with the number of poles, e.g. 714-91-2**xx**-41-001 for a double row version with 8 pins per row becomes: 714-91-2**16**-41-001

Option:

Double row, disposable carrier strip on request

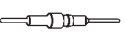
Platings	Sleeve 	Clip 	Pin 
91	5 μ m Sn Pb	0.25 μ m Au	
93	5 μ m Sn Pb	0.75 μ m Au	
99	5 μ m Sn Pb	5 μ m Sn Pb	

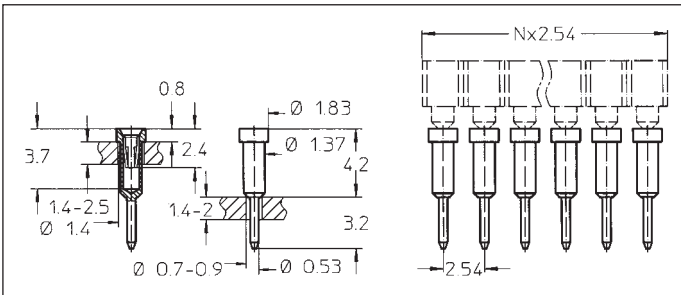

- 712-91-1xx-41-001
- 712-93-1xx-41-001
- 712-99-1xx-41-001

Straight receptacle contacts: solder mount, into PCB thickness 1.4 to 2 mm with hole \varnothing 0.7 to 0.9 mm

Availability: supplied on single row, disposable carrier strip, from 2 to 64 contacts
Standard number of contacts 5, 6, 8, 10, 14, 16, 20, 21, 25, 30, 32, 48, 56, 60, 64

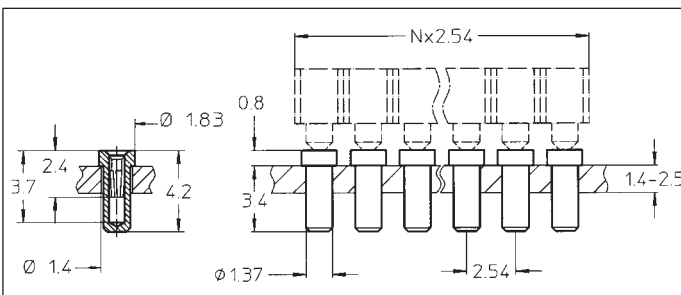

- 714-91-1xx-41-001
- 714-93-1xx-41-001
- 714-99-1xx-41-001

Straight receptacle contacts: solder mount into PCB thickness 1 to 2.6 mm with hole \varnothing 1.5 mm

Availability: supplied on single row, disposable carrier strip, from 2 to 64 contacts
Standard number of contacts 5, 6, 8, 10, 14, 16, 20, 21, 25, 30, 32, 48, 56, 60, 64

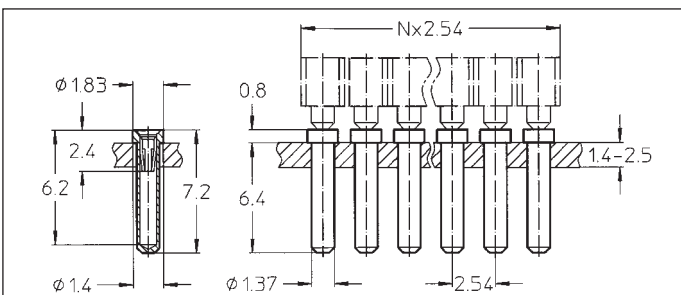

- 714-91-1xx-41-014 **B**
- 714-93-1xx-41-014 **B**
- 714-99-1xx-41-014 **B**

Straight receptacle contacts: solder mount into PCB thickness 1 to 4 mm with hole \varnothing 1.5 mm

Availability: supplied on single row, disposable carrier strip, from 2 to 64 contacts
Standard number of contacts 5, 6, 8, 10, 14, 16, 20, 21, 25, 30, 32, 48, 56, 60, 64

Series 714

PCB connectors carrier assemblies 2.54 mm

Single row / double row

Solder tail / press-fit

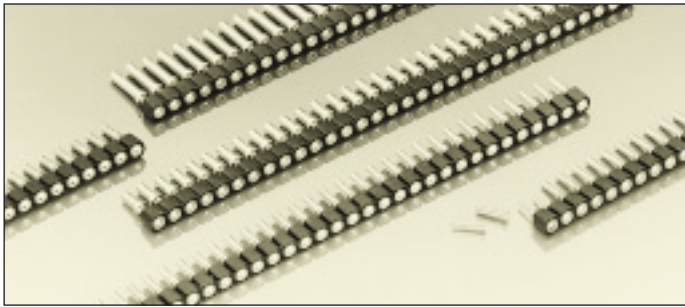

PCB "Zero profile" receptacles

Accept pins \varnothing 0.40–0.54 mm



Single receptacle contacts for solder- and press-fit solderless mount into PCB, supplied on disposable carriers



For corresponding pin connectors see pages 43 to 46

Ordering information

Replace **xx** with the number of poles, e.g. 714-91-1**xx**-31-012 for a single row version with 8 pins per row becomes: 714-91-1**08**-31-012

Option:

Double row, disposable carrier strip on request

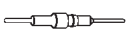
Platings	Sleeve 	Clip 	Pin 
91	5 μ m Sn Pb	0.25 μ m Au	
93	5 μ m Sn Pb	0.75 μ m Au	
99	5 μ m Sn Pb	5 μ m Sn Pb	

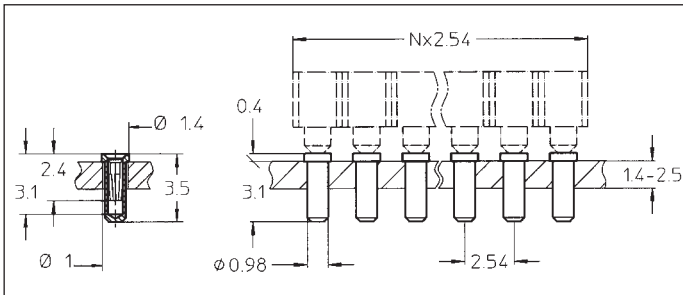

- 714-91-1xx-31-012
- 714-93-1xx-31-012
- 714-99-1xx-31-012

Straight receptacle contacts: solder mount into PCB thickness 1 to 2.4 mm with hole \varnothing 1 mm

Availability: supplied on single row, disposable carrier strip, from 2 to 64 contacts
Standard number of contacts 5, 6, 8, 10, 14, 16, 20, 21, 25, 30, 32, 48, 56, 60, 64

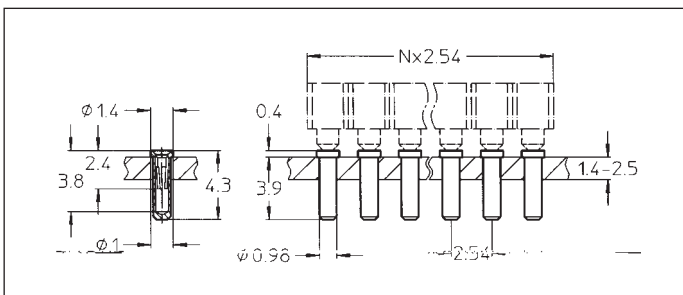

- 714-91-1xx-31-018
- 714-93-1xx-31-018
- 714-99-1xx-31-018

Straight receptacle contacts: solder mount into PCB thickness 1 to 3.4 mm with hole \varnothing 1 mm

Availability: supplied on single row, disposable carrier strip, from 2 to 64 contacts
Standard number of contacts 5, 6, 8, 10, 14, 16, 20, 21, 25, 30, 32, 48, 56, 60, 64

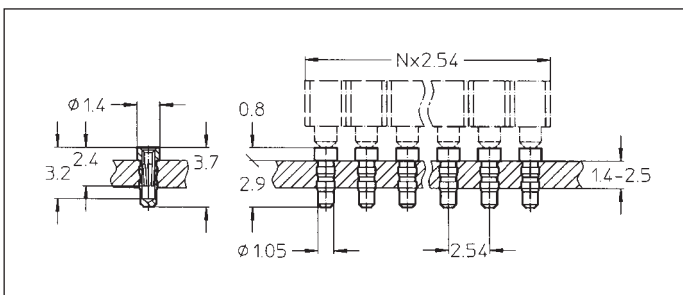

- 714-91-1xx-31-008 **B**
- 714-93-1xx-31-008 **B**
- 714-99-1xx-31-008 **B**

Straight receptacle contacts: solderless press-fit mount into PCB thickness 1.5 to 2.5 mm with plated-thru hole \varnothing 1.05 mm (\pm 0.05)

Availability: supplied on single row, disposable carrier strip, from 2 to 64 contacts
Standard number of contacts 5, 6, 8, 10, 14, 16, 20, 21, 25, 30, 32, 48, 56, 60, 64

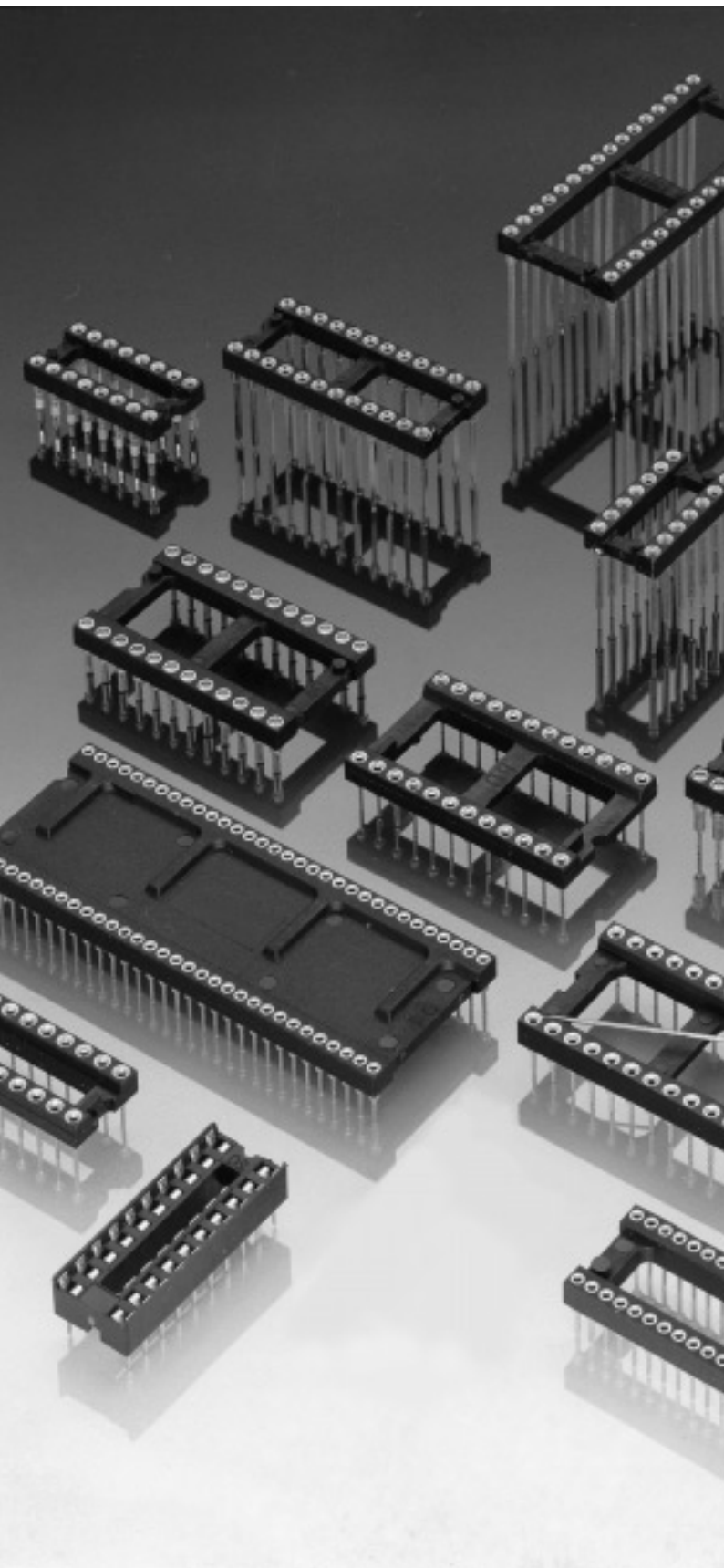

Technical specifications

Materials

- Insulator: Glass filled thermoplastic polyester, self extinguishing UL 94 V-0, colour black, resistant to mineral acids, solvents, greases, oils (short time).
- Receptacle contact:
 - Sleeve: Screw-machined brass (QQ-B-626), gold or tin-lead plated (90/10) over 2–3 μm nickel
 - Clip: Stamped beryllium-copper (QQ-C-533), gold or tin-lead (90/10) plated over 2–3 μm nickel
- Pin contact: Screw-machined brass (QQ-B-626) or phosphor bronze (QQ-B-750), gold or tin-lead plated (90/10) over 2–3 μm nickel

Mechanical data

- Insertion characteristics (measured with a polished steel gauge, typical values):
- Type of clip (finger):

4	4	3	6
standard	short		
- Gauge diameter (mm): 0.43 0.43 0.43 0.46
- Insertion force (N): 1.8 2 1 0.6
- Withdrawal force (N): 0.9 1 0.5 0.3
- Mechanical life: min. 100 cycles

Electrical data

- Rated current: 1 A
- Rated voltage: 100 V_{RMS} / 150 V_{DC}
- Contact resistance: 10 $\text{m}\Omega$ max.
- Insulation resistance: 10 000 $\text{M}\Omega$ min.
- Dielectric strength: 1000 V_{RMS} min.
(700 for Series 117 Shrink-Dip)
- Air and creepage distances: 0.6 mm
(0.3 for Series 117 Shrink-Dip)
- Capacitance: 0.3 pF max.
(1 for series 117 Shrink-Dip)

Environmental data

- Operating temperature: -55/+125 $^{\circ}\text{C}$
- Vibration (10–2000 Hz, 15 g): no electrical discontinuity > 1 μs
- Shock: (50 g): no electrical discontinuity > 1 μs
- Solderability (IEC 68-2-54 Ta): 235 $^{\circ}\text{C}$, 5 s
- Resistance to soldering heat: (IEC 68-2-20 Tb): 260 $^{\circ}\text{C}$, 5 s
- Resistance to atmospheric corrosion: IEC 68-2-42 and 43
- Climatic category (IEC): 55/125/21

PRECI-DIP

DURTAL

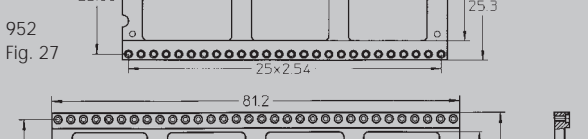
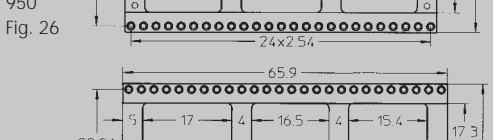
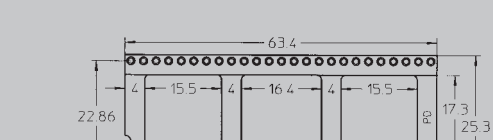
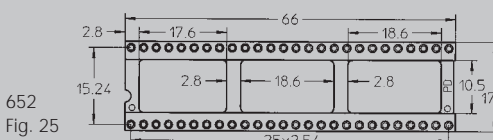
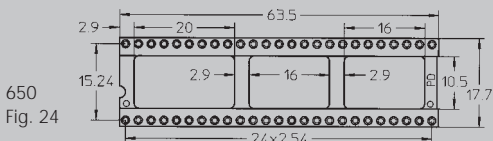
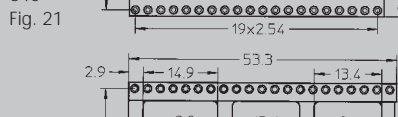
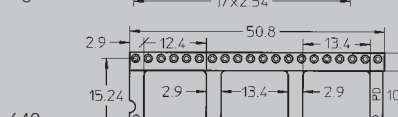
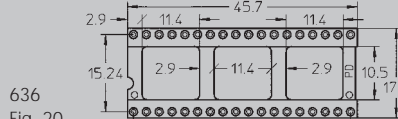
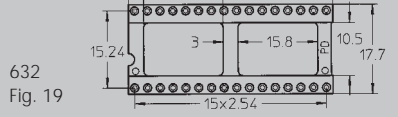
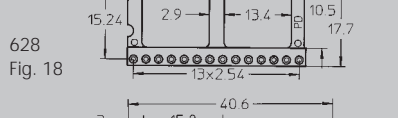
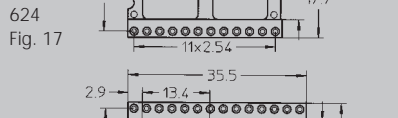
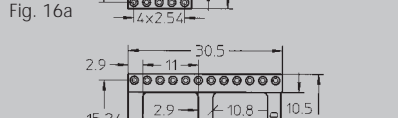
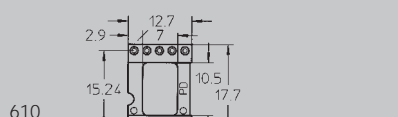
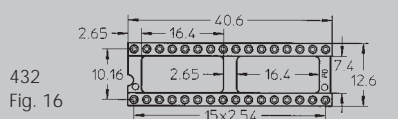
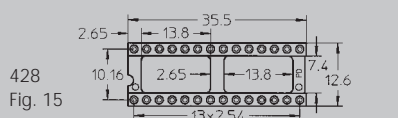
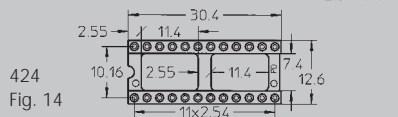
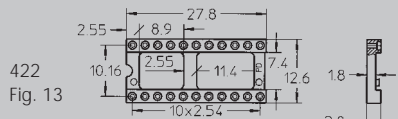
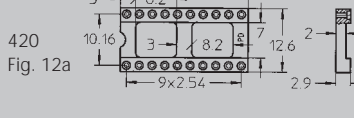
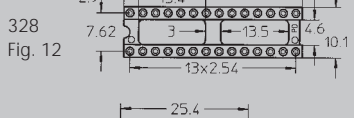
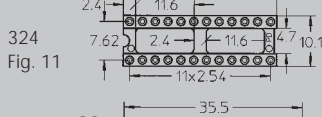
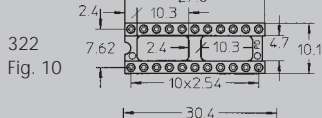
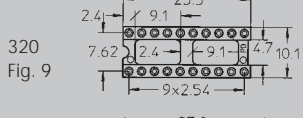
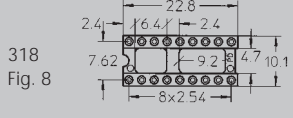
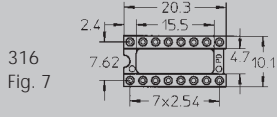
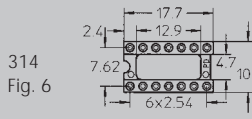
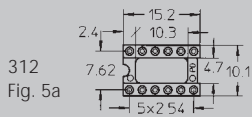
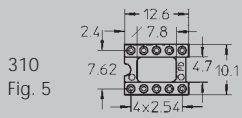
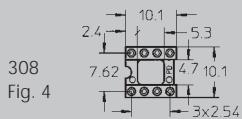
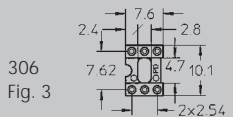
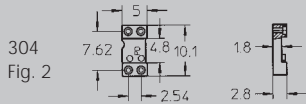
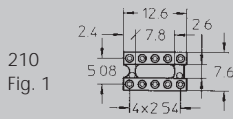

Open frame insulators 318, 320, 322, 324, 624, 628, 632, 640 and 648 available on special request without center bars.

Order number same as the corresponding socket with bars but with suffix 050 added.

Example:
110-93-628-41-001 standard
110-93-628-41-001050
Same but without center bar.

Standard, open frame

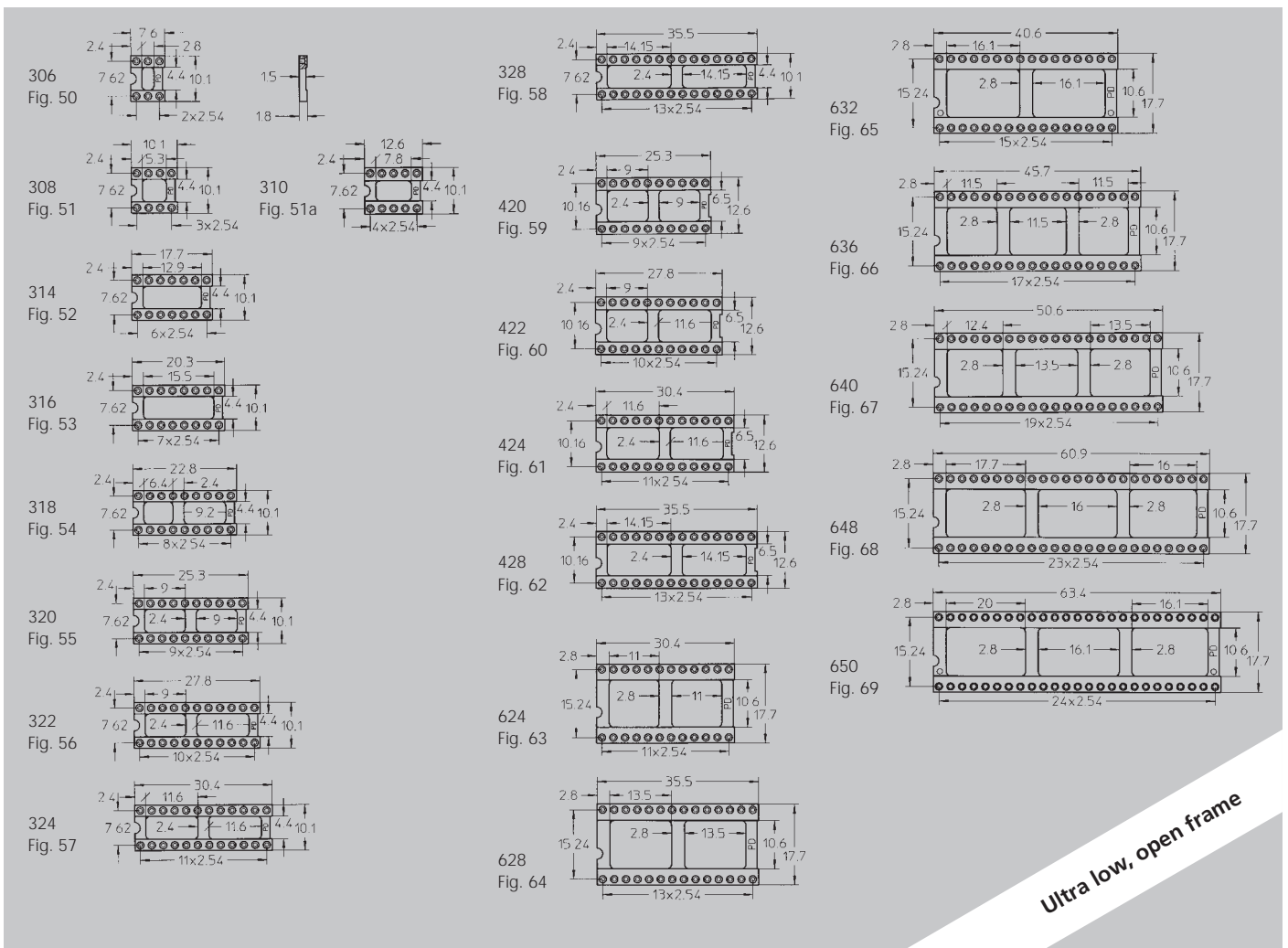
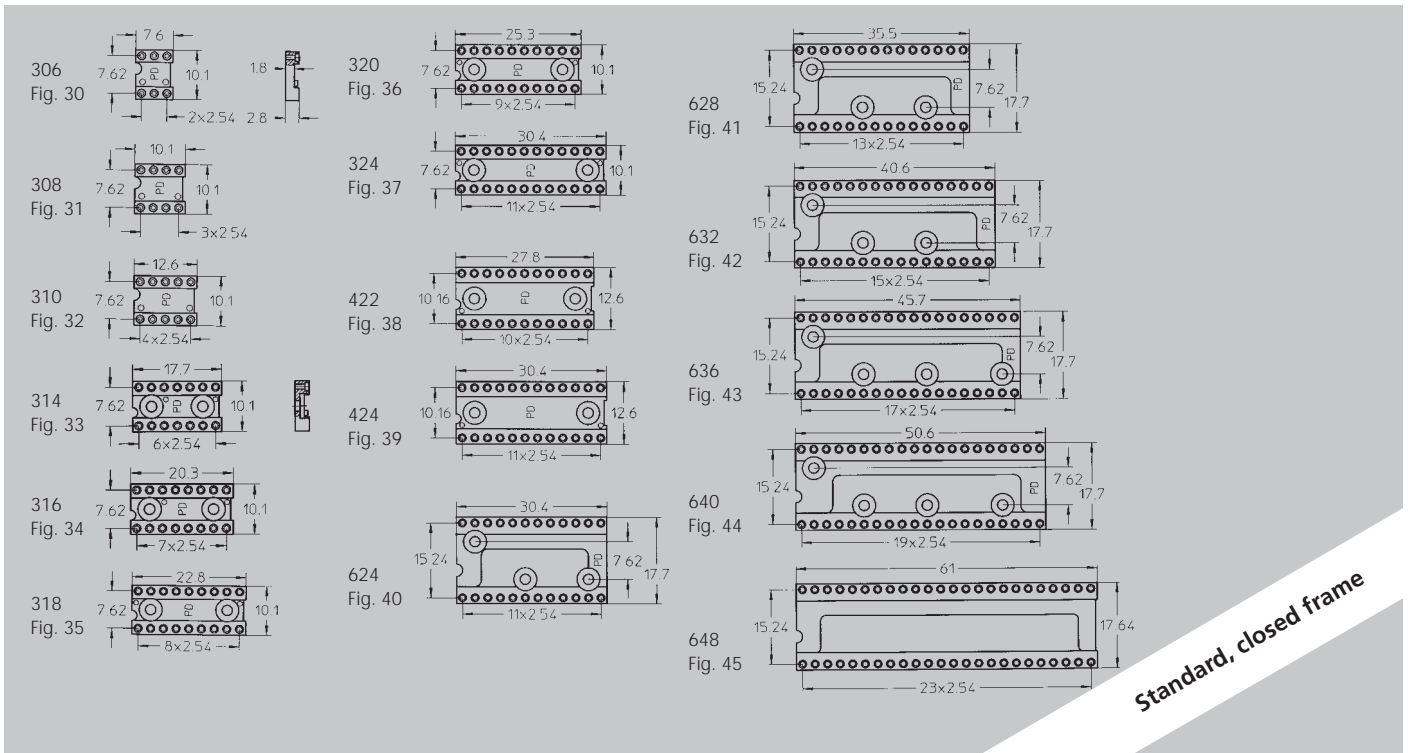

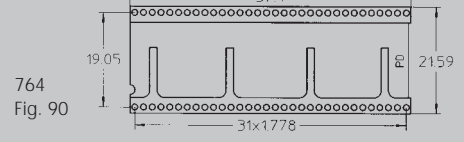
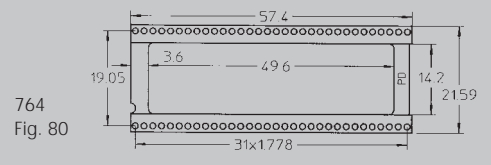
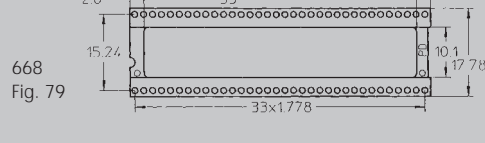
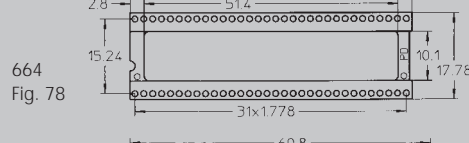
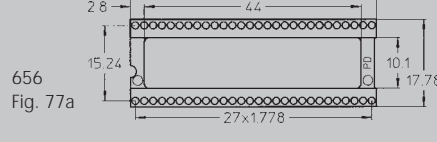
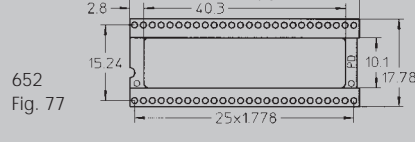
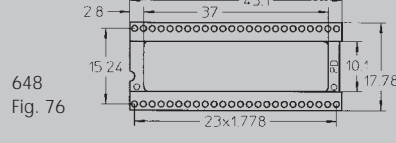
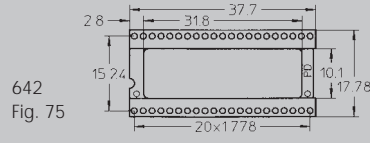
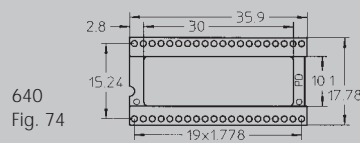
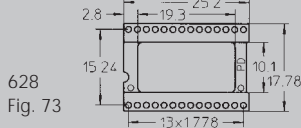
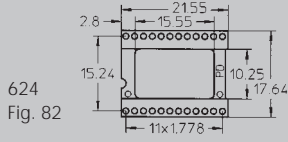
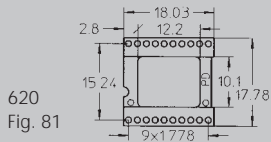
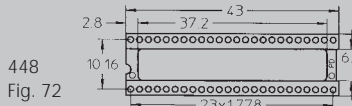
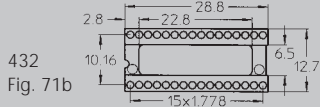
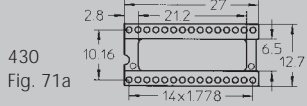
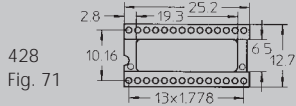
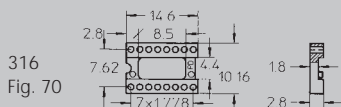

**Shrinkdip,
open and closed frame**

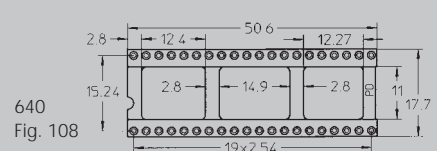
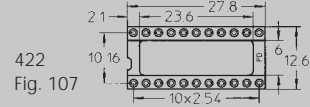
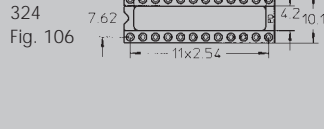
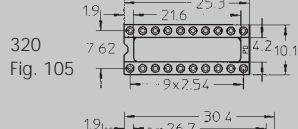
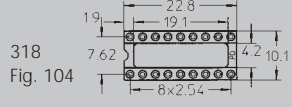
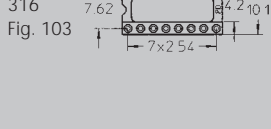
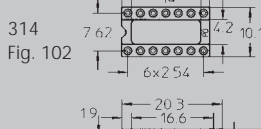
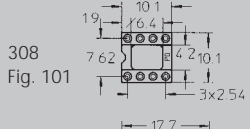
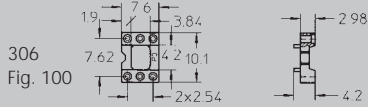

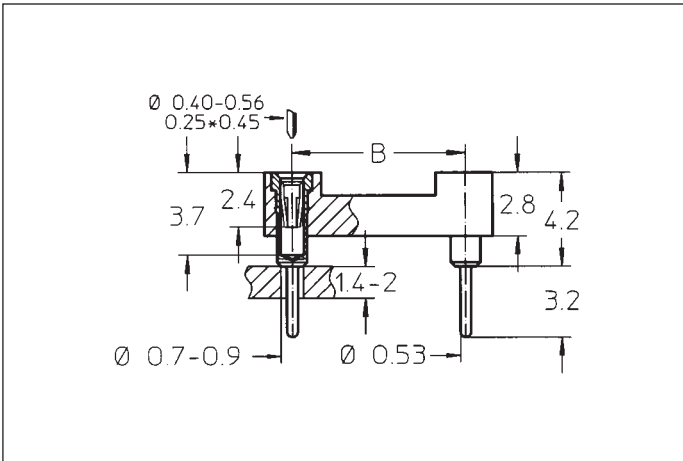

**Automatic insertion,
open frame**

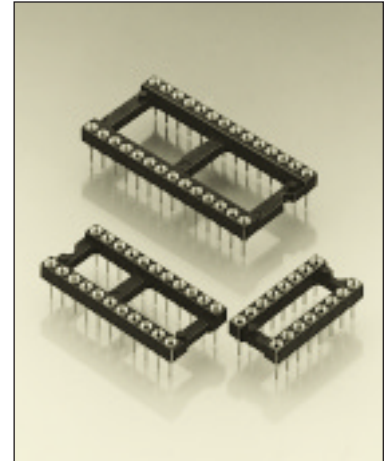

Most popular line of standard low profile IC-Sockets.
Open frame design leaves space beneath IC for improved heat dissipation, easier PCB cleaning and inspections
Insertion characteristics:
4-finger standard



Platings	Sleeve 	Clip 	Pin 
13	0.25 µm Au	0.75 µm Au	
91	5 µm Sn Pb	0.25 µm Au	
93	5 µm Sn Pb	0.75 µm Au	
97	5 µm Sn Pb	Goldflash	
99	5 µm Sn Pb	5 µm Sn Pb	

Ordering information

For standard versions see table (order codes)

Option (*):

Open frame insulators 318, 320, 322, 324, 624, 628, 632, 640 and 648 available on special request without center bars; add suffix 050 to the part number. Example: 110-93-628-41-001 becomes: 110-93-628-41-001-050

No. of poles	Order Codes					Insulator dimensions	Insulator dimensions		
	Plating 13 B	Plating 91	Plating 93	Plating 97	Plating 99		See page 50	A	B
10	110-13-210-41-001	110-91-210-41-001	110-93-210-41-001	110-97-210-41-001	110-99-210-41-001	Fig. 1	12.6	5.08	7.6
4	110-13-304-41-001	110-91-304-41-001	110-93-304-41-001	110-97-304-41-001	110-99-304-41-001	Fig. 2	5.0	7.62	10.1
6	110-13-306-41-001	110-91-306-41-001	110-93-306-41-001	110-97-306-41-001	110-99-306-41-001	Fig. 3	7.6	7.62	10.1
8	110-13-308-41-001	110-91-308-41-001	110-93-308-41-001	110-97-308-41-001	110-99-308-41-001	Fig. 4	10.1	7.62	10.1
10	110-13-310-41-001	110-91-310-41-001	110-93-310-41-001	110-97-310-41-001	110-99-310-41-001	Fig. 5	12.6	7.62	10.1
12	110-13-312-41-001	110-91-312-41-001	110-93-312-41-001	110-97-312-41-001	110-99-312-41-001	Fig. 5a	15.2	7.62	10.1
14	110-13-314-41-001	110-91-314-41-001	110-93-314-41-001	110-97-314-41-001	110-99-314-41-001	Fig. 6	17.7	7.62	10.1
16	110-13-316-41-001	110-91-316-41-001	110-93-316-41-001	110-97-316-41-001	110-99-316-41-001	Fig. 7	20.3	7.62	10.1
18*	110-13-318-41-001	110-91-318-41-001	110-93-318-41-001	110-97-318-41-001	110-99-318-41-001	Fig. 8	22.8	7.62	10.1
20*	110-13-320-41-001	110-91-320-41-001	110-93-320-41-001	110-97-320-41-001	110-99-320-41-001	Fig. 9	25.3	7.62	10.1
22*	110-13-322-41-001	110-91-322-41-001	110-93-322-41-001	110-97-322-41-001	110-99-322-41-001	Fig. 10	27.8	7.62	10.1
24*	110-13-324-41-001	110-91-324-41-001	110-93-324-41-001	110-97-324-41-001	110-99-324-41-001	Fig. 11	30.4	7.62	10.1
28	110-13-328-41-001	110-91-328-41-001	110-93-328-41-001	110-97-328-41-001	110-99-328-41-001	Fig. 12	35.5	7.62	10.1
20	110-13-420-41-001	110-91-420-41-001	110-93-420-41-001	110-97-420-41-001	110-99-420-41-001	Fig. 12a	25.3	10.16	12.6
22	110-13-422-41-001	110-91-422-41-001	110-93-422-41-001	110-97-422-41-001	110-99-422-41-001	Fig. 13	27.8	10.16	12.6
24	110-13-424-41-001	110-91-424-41-001	110-93-424-41-001	110-97-424-41-001	110-99-424-41-001	Fig. 14	30.4	10.16	12.6
28	110-13-428-41-001	110-91-428-41-001	110-93-428-41-001	110-97-428-41-001	110-99-428-41-001	Fig. 15	35.5	10.16	12.6
32	110-13-432-41-001	110-91-432-41-001	110-93-432-41-001	110-97-432-41-001	110-99-432-41-001	Fig. 16	40.6	10.16	12.6
10	110-13-610-41-001	110-91-610-41-001	110-93-610-41-001	110-97-610-41-001	110-99-610-41-001	Fig. 16a	12.6	15.24	17.7
24*	110-13-624-41-001	110-91-624-41-001	110-93-624-41-001	110-97-624-41-001	110-99-624-41-001	Fig. 17	30.4	15.24	17.7
28*	110-13-628-41-001	110-91-628-41-001	110-93-628-41-001	110-97-628-41-001	110-99-628-41-001	Fig. 18	35.5	15.24	17.7
32*	110-13-632-41-001	110-91-632-41-001	110-93-632-41-001	110-97-632-41-001	110-99-632-41-001	Fig. 19	40.6	15.24	17.7
36	110-13-636-41-001	110-91-636-41-001	110-93-636-41-001	110-97-636-41-001	110-99-636-41-001	Fig. 20	45.7	15.24	17.7
40*	110-13-640-41-001	110-91-640-41-001	110-93-640-41-001	110-97-640-41-001	110-99-640-41-001	Fig. 21	50.6	15.24	17.7
42	110-13-642-41-001	110-91-642-41-001	110-93-642-41-001	110-97-642-41-001	110-99-642-41-001	Fig. 22	53.2	15.24	17.7
48*	110-13-648-41-001	110-91-648-41-001	110-93-648-41-001	110-97-648-41-001	110-99-648-41-001	Fig. 23	60.9	15.24	17.7
50	110-13-650-41-001	110-91-650-41-001	110-93-650-41-001	110-97-650-41-001	110-99-650-41-001	Fig. 24	63.4	15.24	17.7
52	110-13-652-41-001	110-91-652-41-001	110-93-652-41-001	110-97-652-41-001	110-99-652-41-001	Fig. 25	65.9	15.24	17.7
50	110-13-950-41-001	110-91-950-41-001	110-93-950-41-001	110-97-950-41-001	110-99-950-41-001	Fig. 26	63.4	22.86	25.3
52	110-13-952-41-001	110-91-952-41-001	110-93-952-41-001	110-97-952-41-001	110-99-952-41-001	Fig. 27	65.9	22.86	25.3
64	110-13-964-41-001	110-91-964-41-001	110-93-964-41-001	110-97-964-41-001	110-99-964-41-001	Fig. 28	81.1	22.86	25.3

B Products not available from stock. Please consult PRECI-DIP.

Series 111

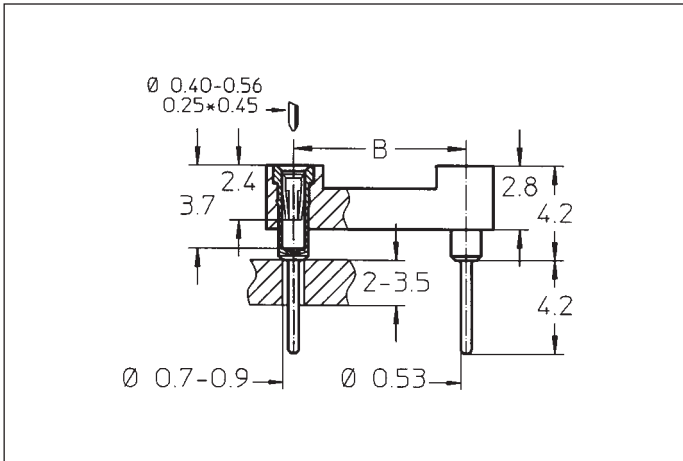

**Dual-in-line sockets for multilayer PCB
Open frame
Solder tail**

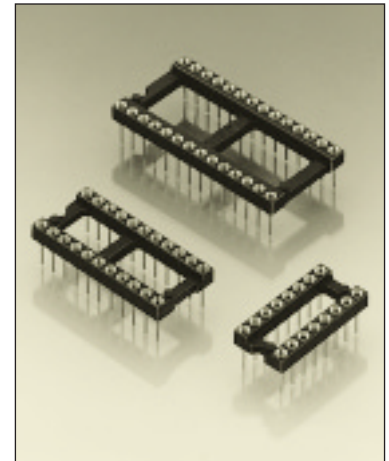

Standard Dual-in-line socket with increased solder tail length of 4.2 mm, allowing application on multilayer PCBs up to 3.4 mm thickness. Other lengths on request

Insertion characteristics:
4-finger standard



Platings	Sleeve 	Clip 	Pin 
91	5 µm Sn Pb	0.25 µm Au	
93	5 µm Sn Pb	0.75 µm Au	
99	5 µm Sn Pb	5 µm Sn Pb	

Ordering information

For complete part number see Order Codes list below

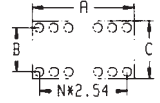
No. of poles	Order Codes			Insulator dimensions 
	Plating 91 B	Plating 93 B	Plating 99 B	
	See page 50	A	B	C
10	111-91-210-41-001	111-93-210-41-001	111-99-210-41-001	Fig. 1 12.6 5.08 7.6
4	111-91-304-41-001	111-93-304-41-001	111-99-304-41-001	Fig. 2 5.0 7.62 10.1
6	111-91-306-41-001	111-93-306-41-001	111-99-306-41-001	Fig. 3 7.6 7.62 10.1
8	111-91-308-41-001	111-93-308-41-001	111-99-308-41-001	Fig. 4 10.1 7.62 10.1
10	111-91-310-41-001	111-93-310-41-001	111-99-310-41-001	Fig. 5 12.6 7.62 10.1
12	111-91-312-41-001	111-93-312-41-001	111-99-312-41-001	Fig. 5a 15.2 7.62 10.1
14	111-91-314-41-001	111-93-314-41-001	111-99-314-41-001	Fig. 6 17.7 7.62 10.1
16	111-91-316-41-001	111-93-316-41-001	111-99-316-41-001	Fig. 7 20.3 7.62 10.1
18	111-91-318-41-001	111-93-318-41-001	111-99-318-41-001	Fig. 8 22.8 7.62 10.1
20	111-91-320-41-001	111-93-320-41-001	111-99-320-41-001	Fig. 9 25.3 7.62 10.1
22	111-91-322-41-001	111-93-322-41-001	111-99-322-41-001	Fig. 10 27.8 7.62 10.1
24	111-91-324-41-001	111-93-324-41-001	111-99-324-41-001	Fig. 11 30.4 7.62 10.1
28	111-91-328-41-001	111-93-328-41-001	111-99-328-41-001	Fig. 12 35.5 7.62 10.1
20	111-91-420-41-001	111-93-420-41-001	110-99-420-41-001	Fig. 12a 25.3 10.16 12.6
22	111-91-422-41-001	111-93-422-41-001	111-99-422-41-001	Fig. 13 27.8 10.16 12.6
24	111-91-424-41-001	111-93-424-41-001	111-99-424-41-001	Fig. 14 30.4 10.16 12.6
28	111-91-428-41-001	111-93-428-41-001	111-99-428-41-001	Fig. 15 35.5 10.16 12.6
32	111-91-432-41-001	111-93-432-41-001	111-99-432-41-001	Fig. 16 40.6 10.16 12.6
10	111-91-610-41-001	110-93-610-41-001	110-99-610-41-001	Fig. 16a 12.6 15.24 17.7
24	111-91-624-41-001	111-93-624-41-001	111-99-624-41-001	Fig. 17 30.4 15.24 17.7
28	111-91-628-41-001	111-93-628-41-001	111-99-628-41-001	Fig. 18 35.5 15.24 17.7
32	111-91-632-41-001	111-93-632-41-001	111-99-632-41-001	Fig. 19 40.6 15.24 17.7
36	111-91-636-41-001	111-93-636-41-001	111-99-636-41-001	Fig. 20 45.7 15.24 17.7
40	111-91-640-41-001	111-93-640-41-001	111-99-640-41-001	Fig. 21 50.6 15.24 17.7
42	111-91-642-41-001	111-93-642-41-001	111-99-642-41-001	Fig. 22 53.2 15.24 17.7
48	111-91-648-41-001	111-93-648-41-001	111-99-648-41-001	Fig. 23 60.9 15.24 17.7
50	111-91-650-41-001	111-93-650-41-001	111-99-650-41-001	Fig. 24 63.4 15.24 17.7
52	111-91-652-41-001	111-93-652-41-001	111-99-652-41-001	Fig. 25 65.9 15.24 17.7
50	111-91-950-41-001	111-93-950-41-001	111-99-950-41-001	Fig. 26 63.4 22.86 25.3
52	111-91-952-41-001	111-93-952-41-001	111-99-952-41-001	Fig. 27 65.9 22.86 25.3
64	111-91-964-41-001	111-93-964-41-001	111-99-964-41-001	Fig. 28 81.1 22.86 25.3

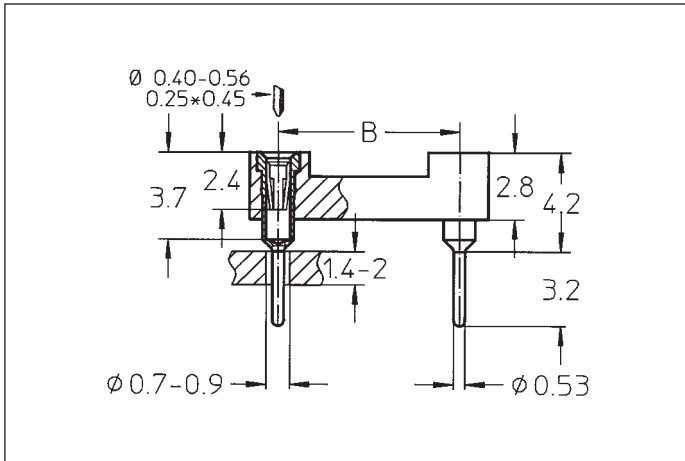

B Products not available from stock. Please consult PRECI-DIP.

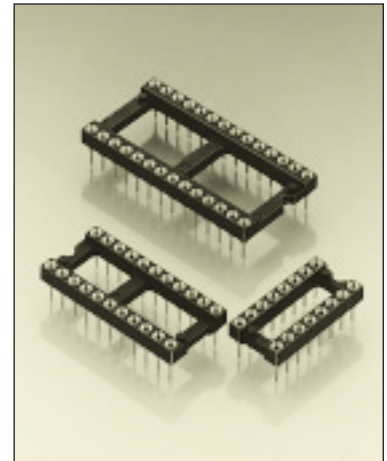

Standard dual-in-line socket with soft copper alloy machined contact allows clinching. Open frame design leaves space beneath IC for improved heat dissipation, easier PCB cleaning and inspections

Insertion characteristics:
4-finger standard



Platings	Sleeve 	Clip 	Pin 
91	5 µm Sn Pb	0.25 µm Au	
93	5 µm Sn Pb	0.75 µm Au	
97	5 µm Sn Pb	Goldflash	
99	5 µm Sn Pb	5 µm Sn Pb	

Ordering information

For standard versions see table (order codes)

Option:

On special request available with solder tail length 4.2 mm, for multilayer boards up to 3.4 mm. Part number: 111-xx-xxx-41-013

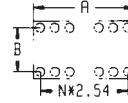
No. of poles	Order Codes				Insulator dimensions			
	Plating 91	Plating 93	Plating 97	Plating 99		See page 50	A	B
10	110-91-210-41-005	110-93-210-41-005	110-97-210-41-005	110-99-210-41-005	Fig. 1	12.6	5.08	7.6
4	110-91-304-41-005	110-93-304-41-005	110-97-304-41-005	110-99-304-41-005	Fig. 2	5.0	7.62	10.1
6	110-91-306-41-005	110-93-306-41-005	110-97-306-41-005	110-99-306-41-005	Fig. 3	7.6	7.62	10.1
8	110-91-308-41-005	110-93-308-41-005	110-97-308-41-005	110-99-308-41-005	Fig. 4	10.1	7.62	10.1
10	110-91-310-41-005	110-93-310-41-005	110-97-310-41-005	110-99-310-41-005	Fig. 5	12.6	7.62	10.1
12	110-91-312-41-005	110-93-312-41-005	110-97-312-41-005	110-99-312-41-005	Fig. 5a	15.2	7.62	10.1
14	110-91-314-41-005	110-93-314-41-005	110-97-314-41-005	110-99-314-41-005	Fig. 6	17.7	7.62	10.1
16	110-91-316-41-005	110-93-316-41-005	110-97-316-41-005	110-99-316-41-005	Fig. 7	20.3	7.62	10.1
18	110-91-318-41-005	110-93-318-41-005	110-97-318-41-005	110-99-318-41-005	Fig. 8	22.8	7.62	10.1
20	110-91-320-41-005	110-93-320-41-005	110-97-320-41-005	110-99-320-41-005	Fig. 9	25.3	7.62	10.1
22	110-91-322-41-005	110-93-322-41-005	110-97-322-41-005	110-99-322-41-005	Fig. 10	27.8	7.62	10.1
24	110-91-324-41-005	110-93-324-41-005	110-97-324-41-005	110-99-324-41-005	Fig. 11	30.4	7.62	10.1
28	110-91-328-41-005	110-93-328-41-005	110-97-328-41-005	110-99-328-41-005	Fig. 12	35.5	7.62	10.1
20	110-91-420-41-005	110-93-420-41-005	110-97-420-41-005	110-99-420-41-005	Fig. 12a	25.3	10.16	12.6
22	110-91-422-41-005	110-93-422-41-005	110-97-422-41-005	110-99-422-41-005	Fig. 13	27.8	10.16	12.6
24	110-91-424-41-005	110-93-424-41-005	110-97-424-41-005	110-99-424-41-005	Fig. 14	30.4	10.16	12.6
28	110-91-428-41-005	110-93-428-41-005	110-97-428-41-005	110-99-428-41-005	Fig. 15	35.5	10.16	12.6
32	110-91-432-41-005	110-93-432-41-005	110-97-432-41-005	110-99-432-41-005	Fig. 16	40.6	10.16	12.6
10	110-91-610-41-005	110-93-610-41-005	110-97-610-41-005	110-99-610-41-005	Fig. 16a	12.6	15.24	17.7
24	110-91-624-41-005	110-93-624-41-005	110-97-624-41-005	110-99-624-41-005	Fig. 17	30.4	15.24	17.7
28	110-91-628-41-005	110-93-628-41-005	110-97-628-41-005	110-99-628-41-005	Fig. 18	35.5	15.24	17.7
32	110-91-632-41-005	110-93-632-41-005	110-97-632-41-005	110-99-632-41-005	Fig. 19	40.6	15.24	17.7
36	110-91-636-41-005	110-93-636-41-005	110-97-636-41-005	110-99-636-41-005	Fig. 20	45.7	15.24	17.7
40	110-91-640-41-005	110-93-640-41-005	110-97-640-41-005	110-99-640-41-005	Fig. 21	50.6	15.24	17.7
42	110-91-642-41-005	110-93-642-41-005	110-97-642-41-005	110-99-642-41-005	Fig. 22	53.2	15.24	17.7
48	110-91-648-41-005	110-93-648-41-005	110-97-648-41-005	110-99-648-41-005	Fig. 23	60.9	15.24	17.7

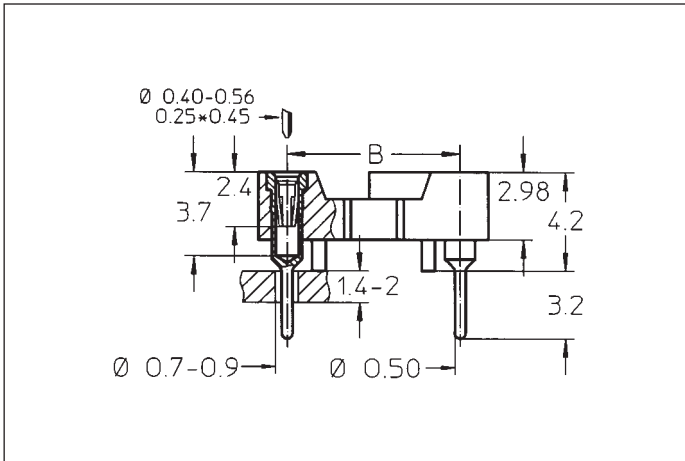



Thanks to the new design of the insulator body, this socket line is fully compatible with all standard automatic insertion equipment

- Chamfered contact entries for easy IC insertion without bent leads.
- Soft copper alloy machined contact allows clinching

Insertion characteristics:
4-finger standard

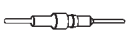

Platings	Sleeve 	Clip 	Pin 
91	5 µm Sn Pb	0.25 µm Au	
93	5 µm Sn Pb	0.75 µm Au	
97	5 µm Sn Pb	Goldflash	
99	5 µm Sn Pb	5 µm Sn Pb	

Ordering information

For standard versions see table (order codes)

Option:

For multilayer boards up to 3.4 mm, solder tail 4.2 mm, we offer series 111-xx-xxx-41-613

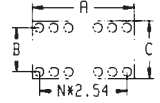
No. of poles	Order Codes				Insulator dimensions 	See page 52	A	B	C
	Plating 91	Plating 93	Plating 97	Plating 99					
6	110-91-306-41-605	110-93-306-41-605	110-97-306-41-605	110-99-306-41-605	Fig. 100	7.6	7.62	10.1	
8	110-91-308-41-605	110-93-308-41-605	110-97-308-41-605	110-99-308-41-605	Fig. 101	10.1	7.62	10.1	
14	110-91-314-41-605	110-93-314-41-605	110-97-314-41-605	110-99-314-41-605	Fig. 102	17.7	7.62	10.1	
16	110-91-316-41-605	110-93-316-41-605	110-97-316-41-605	110-99-316-41-605	Fig. 103	20.3	7.62	10.1	
18	110-91-318-41-605	110-93-318-41-605	110-97-318-41-605	110-99-318-41-605	Fig. 104	22.8	7.62	10.1	
20	110-91-320-41-605	110-93-320-41-605	110-97-320-41-605	110-99-320-41-605	Fig. 105	25.3	7.62	10.1	
24	110-91-324-41-605	110-93-324-41-605	110-97-324-41-605	110-99-324-41-605	Fig. 106	30.4	7.62	10.1	
22	110-91-422-41-605	110-93-422-41-605	110-97-422-41-605	110-99-422-41-605	Fig. 107	27.8	10.16	12.6	
24	110-91-624-41-605	110-93-624-41-605	110-97-624-41-605	110-99-624-41-605	Fig. 17	30.4	15.24	17.7	
28	110-91-628-41-605	110-93-628-41-605	110-97-628-41-605	110-99-628-41-605	Fig. 18	35.5	15.24	17.7	
32	110-91-632-41-605	110-93-632-41-605	110-97-632-41-605	110-99-632-41-605	Fig. 19	40.6	15.24	17.7	
40	110-91-640-41-605	110-93-640-41-605	110-97-640-41-605	110-99-640-41-605	Fig. 108	50.6	15.24	17.7	

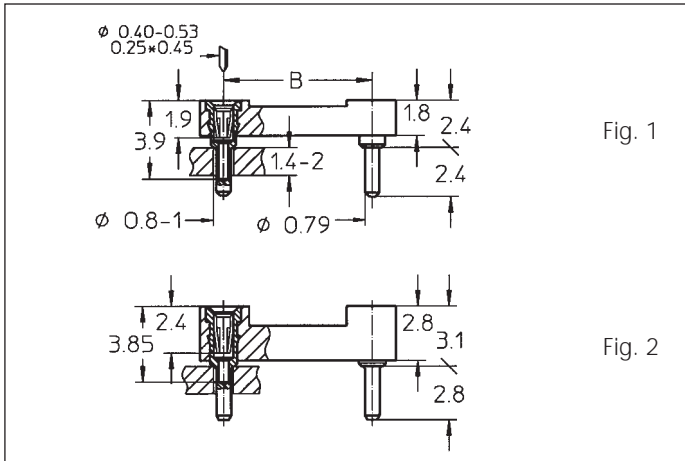
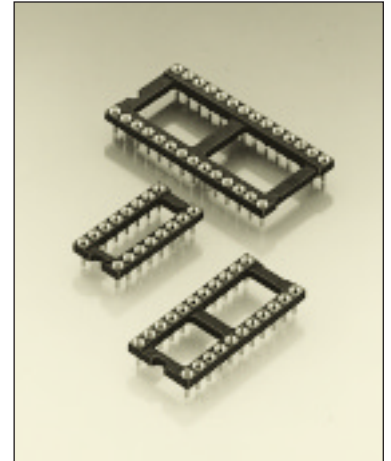





Fig. 1

Fig. 2

Preci-Dip "Very low / Ultra low profile" sockets have specially designed contacts for reduced socket height above PCB

Insertion characteristics:
4-finger standard (very low)
4-finger short (ultra low)



Platings	Sleeve 	Clip 	Pin 
91	5 µm Sn Pb	0.25 µm Au	
93	5 µm Sn Pb	0.75 µm Au	
97	5 µm Sn Pb	Goldflash	
99	5 µm Sn Pb	5 µm Sn Pb	

Ordering information

For standard version (ultra low) (Fig. 1) see table

Option:

Very low version (Fig. 2) is optional; change suffix 003 to 001. Insulator body dimensions see page 50 Fig. 1 to 28. Same number of poles as standard series 110.

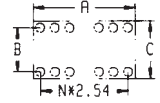
No. of poles	Order Codes					Insulator dimensions 	See page 51		
	Plating 91	Plating 93 B	Plating 97	Plating 99 B	A		B	C	
6	115-91-306-41-003	115-93-306-41-003	115-97-306-41-003	115-99-306-41-003	Fig. 50	7.6	7.62	10.1	
8	115-91-308-41-003	115-93-308-41-003	115-97-308-41-003	115-99-308-41-003	Fig. 51	10.1	7.62	10.1	
10	115-91-310-41-003	115-93-310-41-003	115-97-310-41-003	115-99-310-41-003	Fig. 51a	12.6	7.62	10.1	
14	115-91-314-41-003	115-93-314-41-003	115-97-314-41-003	115-99-314-41-003	Fig. 52	17.7	7.62	10.1	
16	115-91-316-41-003	115-93-316-41-003	115-97-316-41-003	115-99-316-41-003	Fig. 53	20.3	7.62	10.1	
18	115-91-318-41-003	115-93-318-41-003	115-97-318-41-003	115-99-318-41-003	Fig. 54	22.8	7.62	10.1	
20	115-91-320-41-003	115-93-320-41-003	115-97-320-41-003	115-99-320-41-003	Fig. 55	25.3	7.62	10.1	
22	115-91-322-41-003	115-93-322-41-003	115-97-322-41-003	115-99-322-41-003	Fig. 56	27.8	7.62	10.1	
24	115-91-324-41-003	115-93-324-41-003	115-97-324-41-003	115-99-324-41-003	Fig. 57	30.4	7.62	10.1	
28	115-91-328-41-003	115-93-328-41-003	115-97-328-41-003	115-99-328-41-003	Fig. 58	35.5	7.62	10.1	
20	115-91-420-41-003	115-93-420-41-003	115-97-420-41-003	115-99-420-41-003	Fig. 59				
22	115-91-422-41-003	115-93-422-41-003	115-97-422-41-003	115-99-422-41-003	Fig. 60	27.8	10.16	12.6	
24	115-91-424-41-003	115-93-424-41-003	115-97-424-41-003	115-99-424-41-003	Fig. 61	30.4	10.16	12.6	
28	115-91-428-41-003	115-93-428-41-003	115-97-428-41-003	115-99-428-41-003	Fig. 62	35.5	10.16	12.6	
24	115-91-624-41-003	115-93-624-41-003	115-97-624-41-003	115-99-624-41-003	Fig. 63	30.4	15.24	17.7	
28	115-91-628-41-003	115-93-628-41-003	115-97-628-41-003	115-99-628-41-003	Fig. 64	35.5	15.24	17.7	
32	115-91-632-41-003	115-93-632-41-003	115-97-632-41-003	115-99-632-41-003	Fig. 65	40.6	15.24	17.7	
36	115-91-636-41-003	115-93-636-41-003	115-97-636-41-003	115-99-636-41-003	Fig. 66	45.7	15.24	17.7	
40	115-91-640-41-003	115-93-640-41-003	115-97-640-41-003	115-99-640-41-003	Fig. 67	50.6	15.24	17.7	
48	115-91-648-41-003	115-93-648-41-003	115-97-648-41-003	115-99-648-41-003	Fig. 68	60.9	15.24	17.7	
50	115-91-650-41-003	115-93-650-41-003	115-97-650-41-003	115-99-650-41-003	Fig. 69	63.5	15.24	17.7	

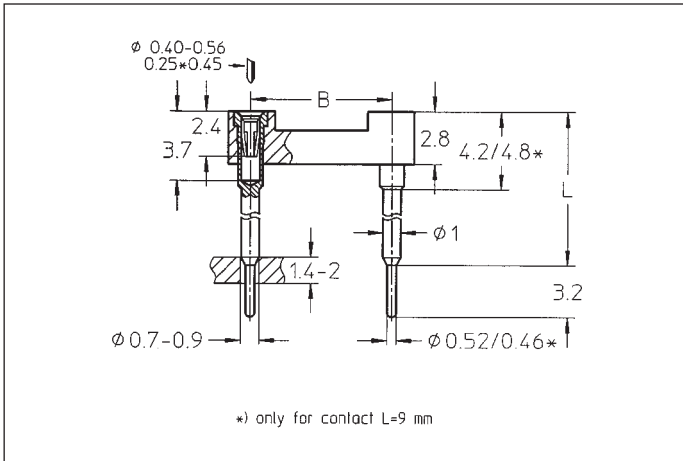



For mechanical and electrical interconnection and stacking of PCBs

Other platings and heights on request

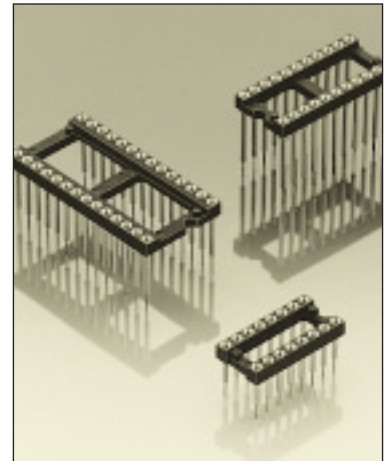
Insertion characteristics:
4-finger standard



Platings	Sleeve 	Clip 	Pin 
93	5 µm Sn Pb	0.75 µm Au	

Ordering information
For complete part number replace **xxx** with the code given in the column corresponding to the required figure for L

No. of poles	Order Codes											Insulator dimensions	Insulator dimensions		
	Plating 93												See page 50	A	B
L =	6 mm	8 mm	9 mm	10 mm	12 mm	13 mm	15 mm	18 mm	22 mm	33 mm					
10	116-93-210-41-xxx	006	003	012	007	008	009	001	011	004	013	Fig. 1	12.6	5.08	7.6
4	116-93-304-41-xxx	006	003	012	007	008	009	001	011	004	013	Fig. 2	5.0	7.62	10.1
6	116-93-306-41-xxx	006	003	012	007	008	009	001	011	004	013	Fig. 3	7.6	7.62	10.1
8	116-93-308-41-xxx	006	003	012	007	008	009	001	011	004	013	Fig. 4	10.1	7.62	10.1
10	116-93-310-41-xxx	006	003	012	007	008	009	001	011	004	013	Fig. 5	12.6	7.62	10.1
12	116-93-312-41-xxx	006	003	012	007	008	009	001	011	004	013	Fig. 5a	15.2	7.62	10.1
14	116-93-314-41-xxx	006	003	012	007	008	009	001	011	004	013	Fig. 6	17.7	7.62	10.1
16	116-93-316-41-xxx	006	003	012	007	008	009	001	011	004	013	Fig. 7	20.3	7.62	10.1
18	116-93-318-41-xxx	006	003	012	007	008	009	001	011	004	013	Fig. 8	22.8	7.62	10.1
20	116-93-320-41-xxx	006	003	012	007	008	009	001	011	004	013	Fig. 9	25.3	7.62	10.1
22	116-93-322-41-xxx	006	003	012	007	008	009	001	011	004	013	Fig. 10	27.8	7.62	10.1
24	116-93-324-41-xxx	006	003	012	007	008	009	001	011	004	013	Fig. 11	30.4	7.62	10.1
28	116-93-328-41-xxx	006	003	012	007	008	009	001	011	004	013	Fig. 12	35.5	7.62	10.1
20	116-93-420-41-xxx	006	003	012	007	008	009	001	011	004	013	Fig. 12a	25.3	10.16	12.6
22	116-93-422-41-xxx	006	003	012	007	008	009	001	011	004	013	Fig. 13	27.8	10.16	12.6
24	116-93-424-41-xxx	006	003	012	007	008	009	001	011	004	013	Fig. 14	30.4	10.16	12.6
28	116-93-428-41-xxx	006	003	012	007	008	009	001	011	004	013	Fig. 15	35.5	10.16	12.6
32	116-93-432-41-xxx	006	003	012	007	008	009	001	011	004	013	Fig. 16	40.6	10.16	12.6
10	116-93-610-41-xxx	006	003	012	007	008	009	001	011	004	013	Fig. 16a	12.6	15.24	17.7
24	116-93-624-41-xxx	006	003	012	007	008	009	001	011	004	013	Fig. 17	30.4	15.24	17.7
28	116-93-628-41-xxx	006	003	012	007	008	009	001	011	004	013	Fig. 18	35.5	15.24	17.7
32	116-93-632-41-xxx	006	003	012	007	008	009	001	011	004	013	Fig. 19	40.6	15.24	17.7
36	116-93-636-41-xxx	006	003	012	007	008	009	001	011	004	013	Fig. 20	45.7	15.24	17.7
40	116-93-640-41-xxx	006	003	012	007	008	009	001	011	004	013	Fig. 21	50.6	15.24	17.7
42	116-93-642-41-xxx	006	003	012	007	008	009	001	011	004	013	Fig. 22	53.2	15.24	17.7
48	116-93-648-41-xxx	006	003	012	007	008	009	001	011	004	013	Fig. 23	60.9	15.24	17.7
50	116-93-650-41-xxx	006	003	012	007	008	009	001	011	004	013	Fig. 24	63.4	15.24	17.7
52	116-93-652-41-xxx	006	003	012	007	008	009	001	011	004	013	Fig. 25	65.9	15.24	17.7
50	116-93-950-41-xxx	006	003	012	007	008	009	001	011	004	013	Fig. 26	63.4	22.86	25.3
52	116-93-952-41-xxx	006	003	012	007	008	009	001	011	004	013	Fig. 27	65.9	22.86	25.3
64	116-93-964-41-xxx	006	003	012	007	008	009	001	011	004	013	Fig. 28	81.1	22.86	25.3

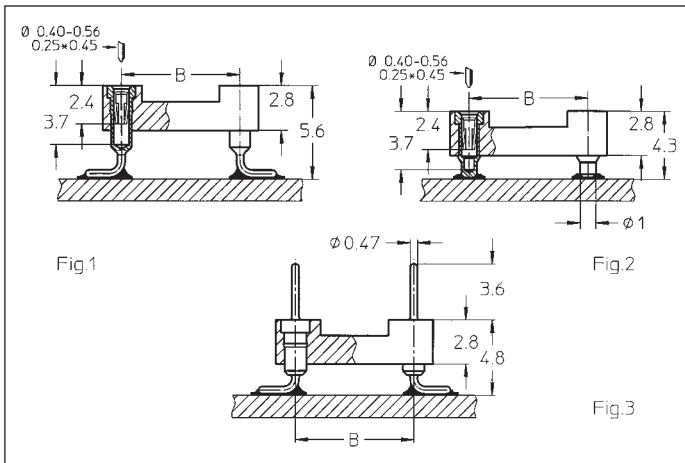



Specially designed for reflow soldering including vapor phase.

Insertion characteristics: receptacle 4-finger standard

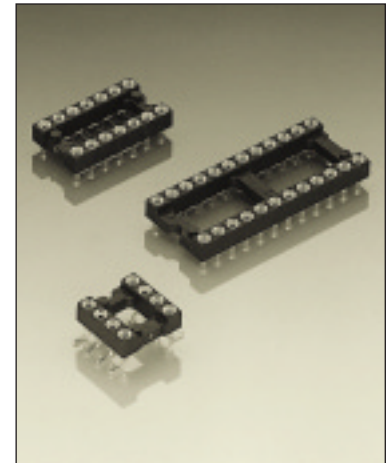
New:
Pin connectors with selective plated precision screw machined pin, plating code Z1.
Connecting side 1: gold plated
soldering/PCB side 2: tin plated



Platings	Sleeve 	Clip 	Pin 
91	5 µm Sn Pb	0.25 µm Au	5 µm Sn Pb 1: 0.25 µm Au 2: 5 µm Sn Pb
99	5 µm Sn Pb	5 µm Sn Pb	
90			
Z1			

Ordering information

Replace **xx** with required plating code. Other platings on request

Series 110-xx-xxx-41-105 and 150-xx-xxx-00-106 with gull wing terminals for maximum strength and easy in-circuit test

Series 114-xx-xxx-41-117 with floating contacts compensate effects of unevenly dispensed solder paste

No. of poles	Order Codes			Insulator dimensions	Insulator dimensions		
	Fig. 1	Fig. 2	Fig. 3		See page 50	A	B
	Plating: see ordering information						
10	110-xx-210-41-105	114-xx-210-41-117	150-xx-210-00-106	Fig. 1	12.6	5.08	7.6
4	110-xx-304-41-105	114-xx-304-41-117	150-xx-304-00-106	Fig. 2	5.0	7.62	10.1
6	110-xx-306-41-105	114-xx-306-41-117	150-xx-306-00-106	Fig. 3	7.6	7.62	10.1
8	110-xx-308-41-105	114-xx-308-41-117	150-xx-308-00-106	Fig. 4	10.1	7.62	10.1
10	110-xx-310-41-105	114-xx-310-41-117	150-xx-310-00-106	Fig. 5	12.6	7.62	10.1
14	110-xx-314-41-105	114-xx-314-41-117	150-xx-314-00-106	Fig. 6	17.7	7.62	10.1
16	110-xx-316-41-105	114-xx-316-41-117	150-xx-316-00-106	Fig. 7	20.3	7.62	10.1
18	110-xx-318-41-105	114-xx-318-41-117	150-xx-318-00-106	Fig. 8	22.8	7.62	10.1
20	110-xx-320-41-105	114-xx-320-41-117	150-xx-320-00-106	Fig. 9	25.3	7.62	10.1
22	110-xx-322-41-105	114-xx-322-41-117	150-xx-322-00-106	Fig. 10	27.8	7.62	10.1
24	110-xx-324-41-105	114-xx-324-41-117	150-xx-324-00-106	Fig. 11	30.4	7.62	10.18
28	110-xx-328-41-105	114-xx-328-41-117	150-xx-328-00-106	Fig. 12	35.5	7.62	10.1
22	110-xx-422-41-105	114-xx-422-41-117	150-xx-422-00-106	Fig. 13	27.8	10.16	12.6
24	110-xx-424-41-105	114-xx-424-41-117	150-xx-424-00-106	Fig. 14	30.4	10.16	12.6
28	110-xx-428-41-105	114-xx-428-41-117	150-xx-428-00-106	Fig. 15	35.5	10.16	12.6
32	110-xx-432-41-105	114-xx-432-41-117	150-xx-432-00-106	Fig. 16	40.6	10.16	12.6
24	110-xx-624-41-105	114-xx-624-41-117	150-xx-624-00-106	Fig. 17	30.4	15.24	17.7
28	110-xx-628-41-105	114-xx-628-41-117	150-xx-628-00-106	Fig. 18	35.5	15.24	17.7
32	110-xx-632-41-105	114-xx-632-41-117	150-xx-632-00-106	Fig. 19	40.6	15.24	17.7
36	110-xx-636-41-105	114-xx-636-41-117	150-xx-636-00-106	Fig. 20	45.7	15.24	17.7
40	110-xx-640-41-105	114-xx-640-41-117	150-xx-640-00-106	Fig. 21	50.6	15.24	17.7
42	110-xx-642-41-105	114-xx-642-41-117	150-xx-642-00-106	Fig. 22	53.2	15.24	17.7
48	110-xx-648-41-105	114-xx-648-41-117	150-xx-648-00-106	Fig. 23	60.9	15.24	17.7

For PCB Layout see page 60:
Fig. 4 Series 110 / 150,
Fig. 5 Series 114

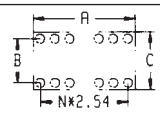

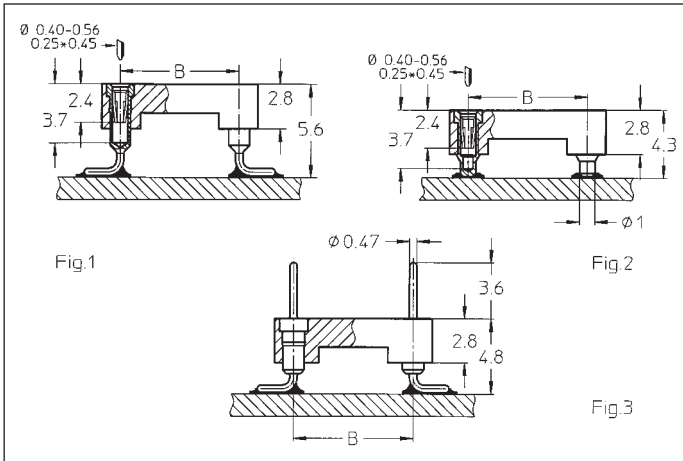



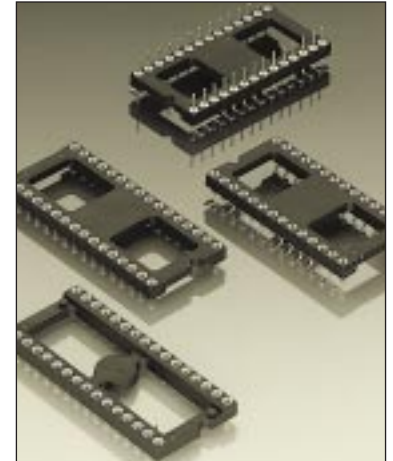

Specially designed for reflow soldering including vapor phase.

Insertion characteristics: receptacle 4-finger standard

New:
Pin connectors with selective plated precision screw machined pin,
plating code Z1.
Connecting side 1:
gold plated
soldering/PCB side 2:
tin plated



Platings	Sleeve 	Clip 	Pin 
91 90 Z1	5 µm Sn Pb	0.25 µm Au	5 µm Sn Pb 1: 0.25 µm Au 2: 5 µm Sn Pb

Ordering information

Replace **xx** with required plating code. Other platings on request

Other pin counts please consult

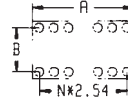
No. of poles	Order Codes				Insulator dimensions 					
	Plating: see ordering information				See	A	B	C	E	G
	Fig. 1 / Fig. 4	Fig. 2 / Fig. 5	Fig. 3 / Fig. 4							
8	110-xx-308-41-105161	114-xx-308-41-134161	150-xx-308-00-106161		Fig. 6	10.1	7.62	10.1		10.1
14	110-xx-314-41-105161	114-xx-314-41-134161	150-xx-314-00-106161		Fig. 6	17.8	7.62	10.1		5.3
16	110-xx-316-41-105161	114-xx-316-41-134161	150-xx-316-00-106161		Fig. 6	20.3	7.62	10.1		5.3
18	110-xx-318-41-105161	114-xx-318-41-134161	150-xx-318-00-106161		Fig. 6	22.9	7.62	10.1		5.3
20	110-xx-320-41-105161	114-xx-320-41-134161	150-xx-320-00-106161		Fig. 6	25.4	7.62	10.1		8.3
24	110-xx-324-41-105161	114-xx-324-41-134161	150-xx-324-00-106161		Fig. 6	30.4	7.62	10.1		8.3
28	110-xx-328-41-105161	114-xx-328-41-134161	150-xx-328-00-106161		Fig. 6	35.6	7.62	10.1		8.3
24	110-xx-624-41-105161	114-xx-624-41-117161	150-xx-624-00-106161		Fig. 7	30.4	15.24	17.7	7	
28	110-xx-628-41-105161	114-xx-628-41-134161	150-xx-628-00-106161		Fig. 6	35.5	15.24	17.7		10
32	110-xx-632-41-105161	114-xx-632-41-134161	150-xx-632-00-106161		Fig. 6	40.6	15.24	17.7		10
40	110-xx-640-41-105161	114-xx-640-41-134161	150-xx-640-00-106161		Fig. 6	50.8	15.24	17.7		10

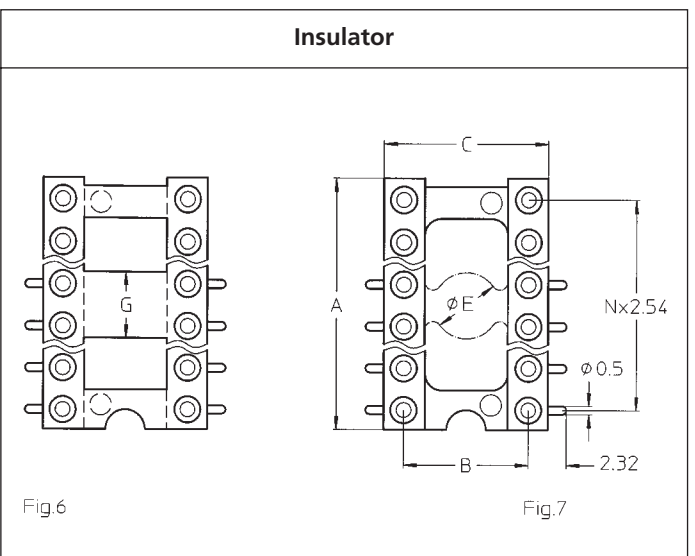
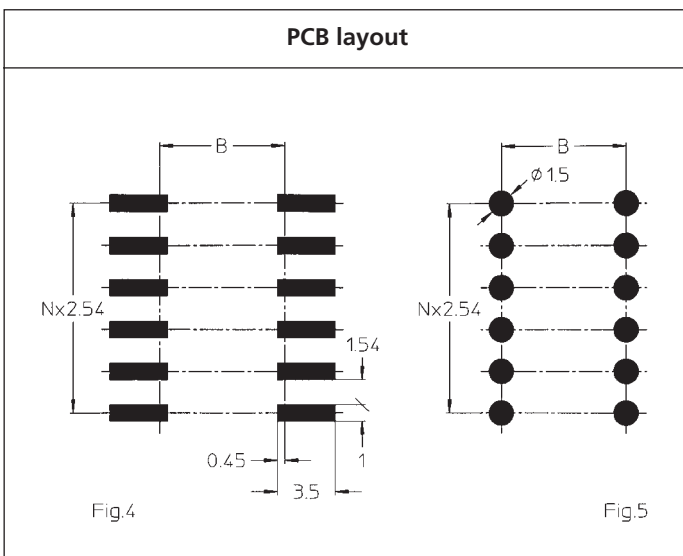

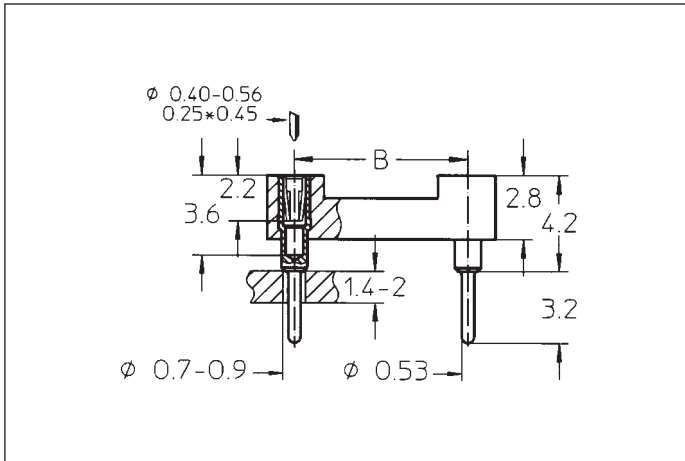

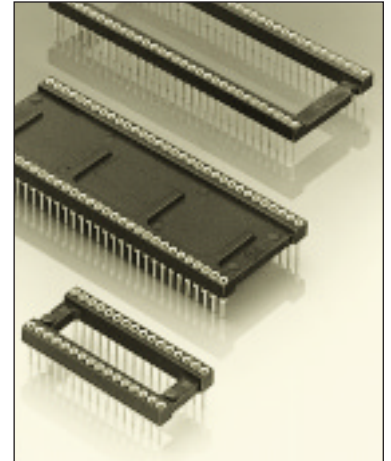

High density Dual-in-line sockets for devices featuring 0.07" (1.778 mm) lead spacing. Four-finger beryllium copper contact meets high vibration and shock requirements

Insertion characteristics:
4-finger standard



Platings	Sleeve 	Clip 	Pin 
91	5 µm Sn Pb	0.25 µm Au	
93	5 µm Sn Pb	0.75 µm Au	
97	5 µm Sn Pb	Goldflash	
99	5 µm Sn Pb	5 µm Sn Pb	

Ordering information

For complete part number see Order Codes list below

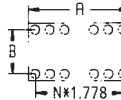
No. of poles	Order Codes				Insulator dimensions 	See page 52	A	B	C
	Plating 91	Plating 93	Plating 97	Plating 99 B					
	Open frame 117								
16	117-91-316-41-005	117-93-316-41-005	117-97-316-41-005	117-99-316-41-005	Fig. 70	14.6	7.62	10.16	
28	117-91-428-41-005	117-93-428-41-005	117-97-428-41-005	117-99-428-41-005	Fig. 71	25.2	10.16	12.7	
30	117-91-430-41-005	117-93-430-41-005	117-97-430-41-005	117-99-430-41-005	Fig. 71a	27.0	10.16	12.7	
32	117-91-432-41-005	117-93-432-41-005	117-97-432-41-005	117-99-432-41-005	Fig. 71b	28.8	10.16	12.7	
48	117-91-448-41-005	117-93-448-41-005	117-97-448-41-005	117-99-448-41-005	Fig. 72	43.0	10.16	12.7	
20	117-91-620-41-005	117-93-620-41-005	117-97-620-41-005	117-99-620-41-005	Fig. 81	18.1	15.24	17.78	
24	117-91-624-41-005	117-93-624-41-005	117-97-624-41-005	117-99-624-41-005	Fig. 82	21.55	15.24	17.64	
28	117-91-628-41-005	117-93-628-41-005	117-97-628-41-005	117-99-628-41-005	Fig. 73	25.2	15.24	17.78	
40	117-91-640-41-005	117-93-640-41-005	117-97-640-41-005	117-99-640-41-005	Fig. 74	35.9	15.24	17.78	
42	117-91-642-41-005	117-93-642-41-005	117-97-642-41-005	117-99-642-41-005	Fig. 75	37.7	15.24	17.78	
48	117-91-648-41-005	117-93-648-41-005	117-97-648-41-005	117-99-648-41-005	Fig. 76	43.1	15.24	17.78	
52	117-91-652-41-005	117-93-652-41-005	117-97-652-41-005	117-99-652-41-005	Fig. 77	46.6	15.24	17.78	
56	117-91-656-41-005	117-93-656-41-005	117-97-656-41-005	117-99-656-41-005	Fig. 77a	50.0	15.24	17.78	
64	117-91-664-41-005	117-93-664-41-005	117-97-664-41-005	117-99-664-41-005	Fig. 78	57.2	15.24	17.78	
68	117-91-668-41-005	117-93-668-41-005	117-97-668-41-005	117-99-668-41-005	Fig. 79	60.8	15.24	17.78	
64	117-91-764-41-005	117-93-764-41-005	117-97-764-41-005	117-99-764-41-005	Fig. 80	57.4	19.05	21.59	
	Closed frame 217								
64	217-91-764-41-005	217-93-764-41-005	217-97-764-41-005	217-99-764-41-005	Fig. 90	57.4	19.05	21.59	

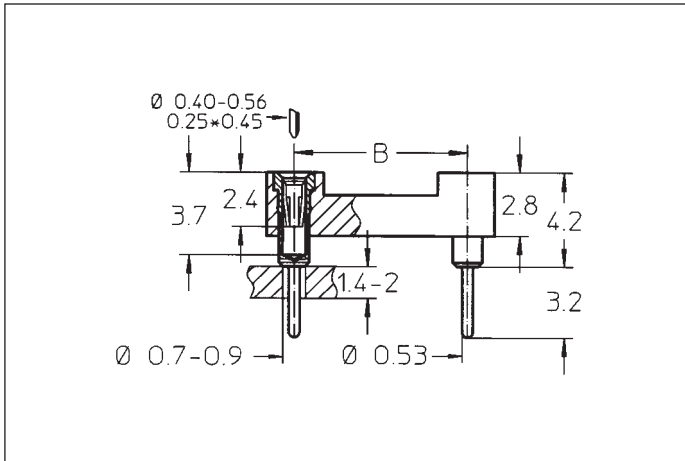



Closed frame "solid" insulator withstands high mechanical impact. Low profile

Available with series 10 standard pins, other types on request

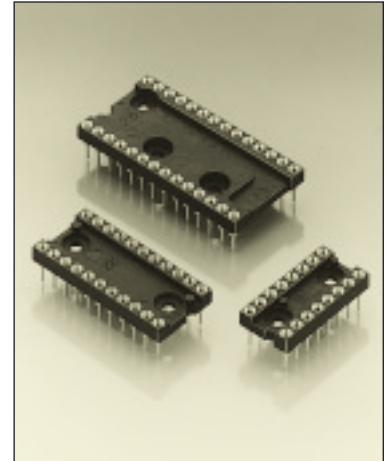
Insertion characteristics:
4-finger standard



Platings	Sleeve 	Clip 	Pin 
91	5 µm Sn Pb	0.25 µm Au	
93	5 µm Sn Pb	0.75 µm Au	
97	5 µm Sn Pb	Goldflash	
99	5 µm Sn Pb	5 µm Sn Pb	

Ordering information

For complete part number see Order Codes list below

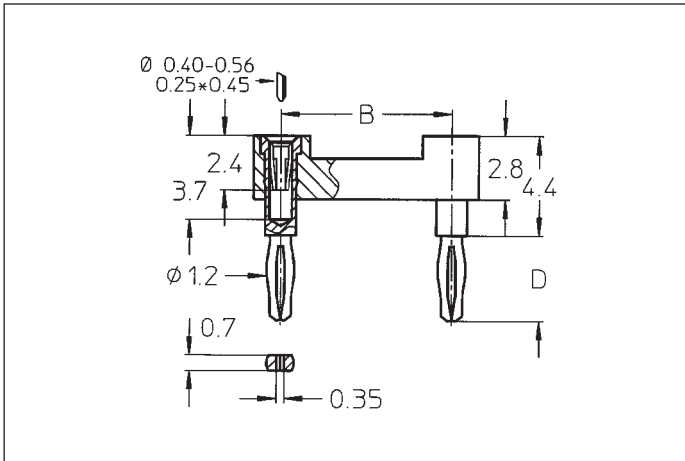

No. of poles	Order Codes				Insulator dimensions	Insulator dimensions		
	Plating 91 B	Plating 93 B	Plating 97 B	Plating 99 B		See page 51	A	B
6	210-91-306-41-001	210-93-306-41-001	210-97-306-41-001	210-99-306-41-001	Fig. 30	7.6	7.62	10.1
8	210-91-308-41-001	210-93-308-41-001	210-97-308-41-001	210-99-308-41-001	Fig. 31	10.1	7.62	10.1
10	210-91-310-41-001	210-93-310-41-001	210-97-310-41-001	210-99-310-41-001	Fig. 32	12.6	7.62	10.1
14	210-91-314-41-001	210-93-314-41-001	210-97-314-41-001	210-99-314-41-001	Fig. 33	17.7	7.62	10.1
16	210-91-316-41-001	210-93-316-41-001	210-97-316-41-001	210-99-316-41-001	Fig. 34	20.3	7.62	10.1
18	210-91-318-41-001	210-93-318-41-001	210-97-318-41-001	210-99-318-41-001	Fig. 35	22.8	7.62	10.1
20	210-91-320-41-001	210-93-320-41-001	210-97-320-41-001	210-99-320-41-001	Fig. 36	25.3	7.62	10.1
24	210-91-324-41-001	210-93-324-41-001	210-97-324-41-001	210-99-324-41-001	Fig. 37	30.4	7.62	10.1
22	210-91-422-41-001	210-93-422-41-001	210-97-422-41-001	210-99-422-41-001	Fig. 38	27.8	10.16	12.6
24	210-91-424-41-001	210-93-424-41-001	210-97-424-41-001	210-99-424-41-001	Fig. 39	30.4	10.16	12.6
24	210-91-624-41-001	210-93-624-41-001	210-97-624-41-001	210-99-624-41-001	Fig. 40	30.4	15.24	17.7
28	210-91-628-41-001	210-93-628-41-001	210-97-628-41-001	210-99-628-41-001	Fig. 41	35.5	15.24	17.7
32	210-91-632-41-001	210-93-632-41-001	210-97-632-41-001	210-99-632-41-001	Fig. 42	40.6	15.24	17.7
36	210-91-636-41-001	210-93-636-41-001	210-97-636-41-001	210-99-636-41-001	Fig. 43	45.7	15.24	17.7
40	210-91-640-41-001	210-93-640-41-001	210-97-640-41-001	210-99-640-41-001	Fig. 44	50.6	15.24	17.7
48	210-91-648-41-001	210-93-648-41-001	210-97-648-41-001	210-99-648-41-001	Fig. 45	61.0	15.24	17.64

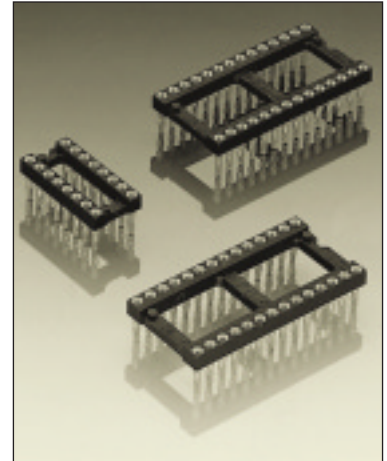

Press-fit sockets for solderless mount into PCB.
For plated-thru-holes
Ø 1 (+0.09/-0.06) mm
Compliant pins

New press-fit receptacle with modified eye of the needle which eliminates damage to the plated-thru-holes

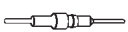

Platings	Sleeve 	Clip 	Pin 
91	5 µm Sn Pb	0.25 µm Au	
93	5 µm Sn Pb	0.75 µm Au	
99	5 µm Sn Pb	5 µm Sn Pb	

Ordering information

For standard versions see table (order codes)

Option:

Platings 91, 93 and 99 available for all versions

Replace **xx** with requested plating code

(Older versions 146...012/013/019 please consult)

No. of poles	Order Codes		Insulator dimensions	Insulator dimensions		
	For PCB thickness 1.5 to 2.0 mm	For PCB thickness 2.1 to 3.2 mm		A	B	C
	D = 2.80 mm	D = 3.80 mm	See page 44			
6	146-xx-306-41-036	146-xx-306-41-035	Fig. 3	7.6	7.62	10.1
8	146-xx-308-41-036	146-xx-308-41-035	Fig. 4	10.1	7.62	10.1
14	146-xx-314-41-036	146-xx-314-41-035	Fig. 6	17.7	7.62	10.1
16	146-xx-316-41-036	146-xx-316-41-035	Fig. 7	20.3	7.62	10.1
18	146-xx-318-41-036	146-xx-318-41-035	Fig. 8	22.8	7.62	10.1
20	146-xx-320-41-036	146-xx-320-41-035	Fig. 9	25.3	7.62	10.1
22	146-xx-422-41-036	146-xx-422-41-035	Fig. 13	27.8	10.16	12.6
24	146-xx-624-41-036	146-xx-624-41-035	Fig. 17	30.4	15.24	17.7
28	146-xx-628-41-036	146-xx-628-41-035	Fig. 18	35.5	15.24	17.7
32	146-xx-632-41-036	146-xx-632-41-035	Fig. 19	40.6	15.24	17.7
40	146-xx-640-41-036	146-xx-640-41-035	Fig. 21	50.6	15.24	17.7

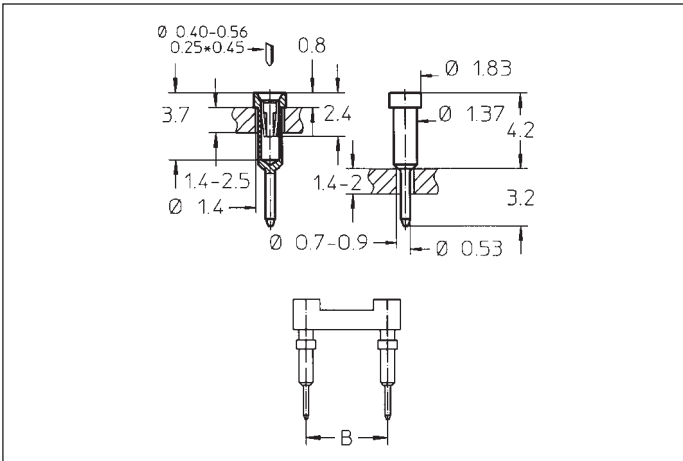



Pin carrier assemblies assure maximum ventilation and better visibility for inspection and repair

Easy mounting due to the disposable plastic carrier. No solder or flux wicking problems

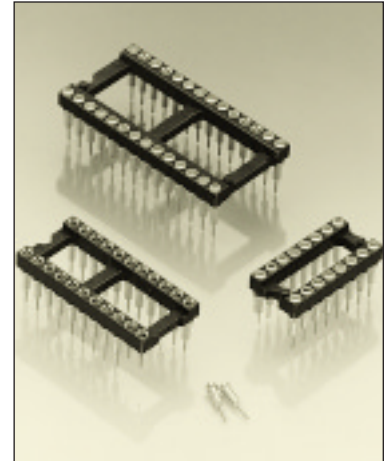
Insertion characteristics:
4-finger standard



Platings	Sleeve 	Clip 	Pin 
91	5 μ m Sn Pb	0.25 μ m Au	
93	5 μ m Sn Pb	0.75 μ m Au	
99	5 μ m Sn Pb	5 μ m Sn Pb	

Ordering information

For complete part number see Order Codes list below

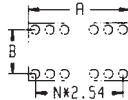
No. of poles	Order Codes			Insulator dimensions 	See page 50	A	B	C
	Plating 91	Plating 93	Plating 99					
10	612-91-210-41-001	612-93-210-41-001	612-99-210-41-001		Fig. 1	12.6	5.08	7.6
4	612-91-304-41-001	612-93-304-41-001	612-99-304-41-001		Fig. 2	5.0	7.62	10.1
6	612-91-306-41-001	612-93-306-41-001	612-99-306-41-001		Fig. 3	7.6	7.62	10.1
8	612-91-308-41-001	612-93-308-41-001	612-99-308-41-001		Fig. 4	10.1	7.62	10.1
10	612-91-310-41-001	612-93-310-41-001	612-99-310-41-001		Fig. 5	12.6	7.62	10.1
12	612-91-312-41-001	612-93-312-41-001	612-99-312-41-001		Fig. 5a	15.2	7.62	10.1
14	612-91-314-41-001	612-93-314-41-001	612-99-314-41-001		Fig. 6	17.7	7.62	10.1
16	612-91-316-41-001	612-93-316-41-001	612-99-316-41-001		Fig. 7	20.3	7.62	10.1
18	612-91-318-41-001	612-93-318-41-001	612-99-318-41-001		Fig. 8	22.8	7.62	10.1
20	612-91-320-41-001	612-93-320-41-001	612-99-320-41-001		Fig. 9	25.3	7.62	10.1
22	612-91-322-41-001	612-93-322-41-001	612-99-322-41-001		Fig. 10	27.8	7.62	10.1
24	612-91-324-41-001	612-93-324-41-001	612-99-324-41-001		Fig. 11	30.4	7.62	10.1
28	612-91-328-41-001	612-93-328-41-001	612-99-328-41-001		Fig. 12	35.5	7.62	10.1
20	612-91-420-41-001	612-93-420-41-001	612-99-420-41-001		Fig. 12a	25.3	10.16	12.6
22	612-91-422-41-001	612-93-422-41-001	612-99-422-41-001		Fig. 13	27.8	10.16	12.6
24	612-91-424-41-001	612-93-424-41-001	612-99-424-41-001		Fig. 14	30.4	10.16	12.6
28	612-91-428-41-001	612-93-428-41-001	612-99-428-41-001		Fig. 15	35.5	10.16	12.6
32	612-91-432-41-001	612-93-432-41-001	612-99-432-41-001		Fig. 16	40.6	10.16	12.6
10	612-91-610-41-001	612-93-610-41-001	612-99-610-41-001		Fig. 16a	12.6	15.24	17.7
24	612-91-624-41-001	612-93-624-41-001	612-99-624-41-001		Fig. 17	30.4	15.24	17.7
28	612-91-628-41-001	612-93-628-41-001	612-99-628-41-001		Fig. 18	35.5	15.24	17.7
32	612-91-632-41-001	612-93-632-41-001	612-99-632-41-001		Fig. 19	40.6	15.24	17.7
36	612-91-636-41-001	612-93-636-41-001	612-99-636-41-001		Fig. 20	45.7	15.24	17.7
40	612-91-640-41-001	612-93-640-41-001	612-99-640-41-001		Fig. 21	50.6	15.24	17.7
42	612-91-642-41-001	612-93-642-41-001	612-99-642-41-001		Fig. 22	53.2	15.24	17.7
48	612-91-648-41-001	612-93-648-41-001	612-99-648-41-001		Fig. 23	60.9	15.24	17.7
50	612-91-650-41-001	612-93-650-41-001	612-99-650-41-001		Fig. 24	63.4	15.24	17.7
52	612-91-652-41-001	612-93-652-41-001	612-99-652-41-001		Fig. 25	65.9	15.24	17.7
50	612-91-950-41-001	612-93-950-41-001	612-99-950-41-001		Fig. 26	63.4	22.86	25.3
52	612-91-952-41-001	612-93-952-41-001	612-99-952-41-001		Fig. 27	65.9	22.86	25.3
64	612-91-964-41-001	612-93-964-41-001	612-99-964-41-001		Fig. 28	81.1	22.86	25.3

Series 614

Dual-in-line pin carrier assemblies
Low profile / low profile ultra thin
Solder tail

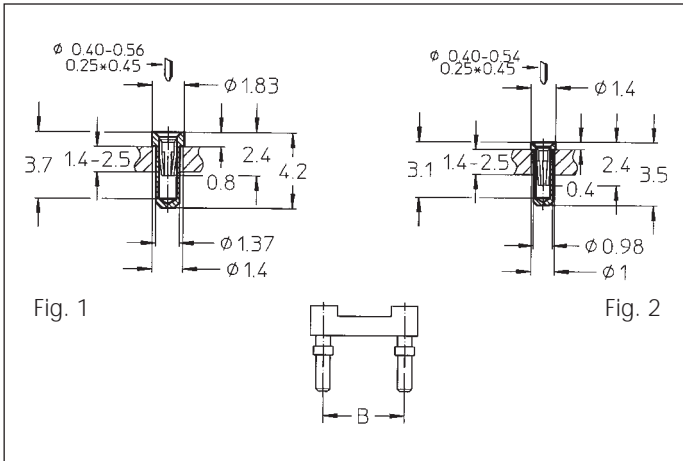





Pin carrier assemblies assure maximum ventilation and better visibility for inspection and repair

Easy mounting due to the disposable plastic carrier. No solder or flux wicking problems

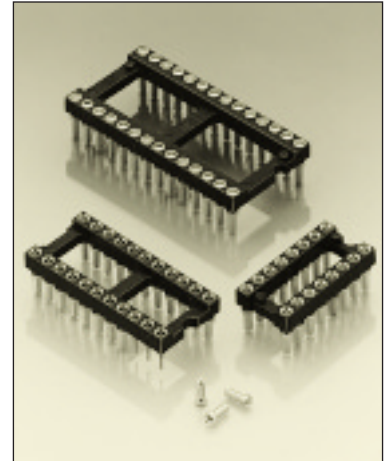
Low profile:
Insertion characteristics:
4-finger standard

Low profile ultra thin:
Requires 1 mm diameter holes in PCB.
Insertion characteristics:
3-finger



Platings	Sleeve 	Clip 	Pin 
91	5 µm Sn Pb	0.25 µm Au	
93	5 µm Sn Pb	0.75 µm Au	
99	5 µm Sn Pb	5 µm Sn Pb	

Ordering information

For standard versions see table (order codes)

Platings available:

Low profile: 614...-41-001: 91, 93, 99

Ultra thin: 614...-31-012: 91, 93, 99

Replace **xx** with required plating code

No. of poles	Order Codes				Insulator dimensions	Insulator dimensions		
	Platings: see ordering information					See page 50	A	B
	Fig. 1	Fig. 2						
10	614-xx-210-41-001	614-xx-210-31-012			Fig. 1	12.6	5.08	7.6
4	614-xx-304-41-001	614-xx-304-31-012			Fig. 2	5.0	7.62	10.1
6	614-xx-306-41-001	614-xx-306-31-012			Fig. 3	7.6	7.62	10.1
8	614-xx-308-41-001	614-xx-308-31-012			Fig. 4	10.1	7.62	10.1
10	614-xx-310-41-001	614-xx-310-31-012			Fig. 5	12.6	7.62	10.1
12	614-xx-312-41-001	614-xx-312-31-012			Fig. 5a	15.2	7.62	10.1
14	614-xx-314-41-001	614-xx-314-31-012			Fig. 6	17.7	7.62	10.1
16	614-xx-316-41-001	614-xx-316-31-012			Fig. 7	20.3	7.62	10.1
18	614-xx-318-41-001	614-xx-318-31-012			Fig. 8	22.8	7.62	10.1
20	614-xx-320-41-001	614-xx-320-31-012			Fig. 9	25.3	7.62	10.1
22	614-xx-322-41-001	614-xx-322-31-012			Fig. 10	27.8	7.62	10.1
24	614-xx-324-41-001	614-xx-324-31-012			Fig. 11	30.4	7.62	10.1
28	614-xx-328-41-001	614-xx-328-31-012			Fig. 12	35.5	7.62	10.1
20	614-xx-420-41-001	614-xx-420-31-012			Fig. 12a	25.3	10.16	12.6
22	614-xx-422-41-001	614-xx-422-31-012			Fig. 13	27.8	10.16	12.6
24	614-xx-424-41-001	614-xx-424-31-012			Fig. 14	30.4	10.16	12.6
28	614-xx-428-41-001	614-xx-428-31-012			Fig. 15	35.5	10.16	12.6
32	614-xx-432-41-001	614-xx-432-31-012			Fig. 16	40.6	10.16	12.6
10	614-xx-610-41-001	614-xx-610-31-012			Fig. 16a	12.6	15.24	17.7
24	614-xx-624-41-001	614-xx-624-31-012			Fig. 17	30.4	15.24	17.7
28	614-xx-628-41-001	614-xx-628-31-012			Fig. 18	35.5	15.24	17.7
32	614-xx-632-41-001	614-xx-632-31-012			Fig. 19	40.6	15.24	17.7
36	614-xx-636-41-001	614-xx-636-31-012			Fig. 20	45.7	15.24	17.7
40	614-xx-640-41-001	614-xx-640-31-012			Fig. 21	50.6	15.24	17.7
42	614-xx-642-41-001	614-xx-642-31-012			Fig. 22	53.2	15.24	17.7
48	614-xx-648-41-001	614-xx-648-31-012			Fig. 23	60.9	15.24	17.7
50	614-xx-650-41-001	614-xx-650-31-012			Fig. 24	63.4	15.24	17.7
52	614-xx-652-41-001	614-xx-652-31-012			Fig. 25	65.9	15.24	17.7
50	614-xx-950-41-001	614-xx-950-31-012			Fig. 26	63.4	22.86	25.3
52	614-xx-952-41-001	614-xx-952-31-012			Fig. 27	65.9	22.86	25.3
64	614-xx-964-41-001	614-xx-964-31-012			Fig. 28	81.1	22.86	25.3

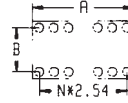

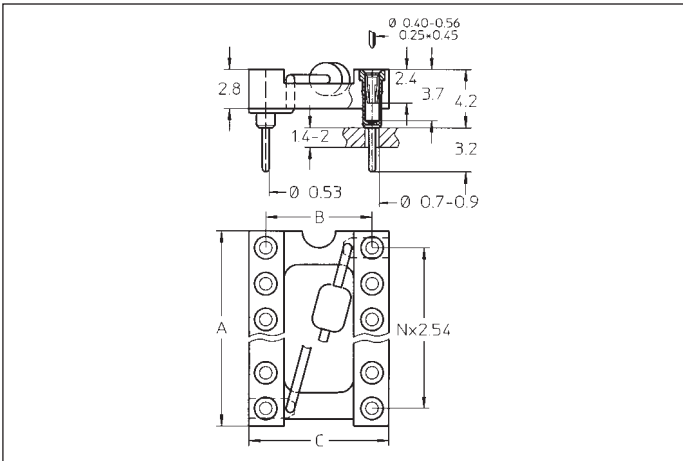



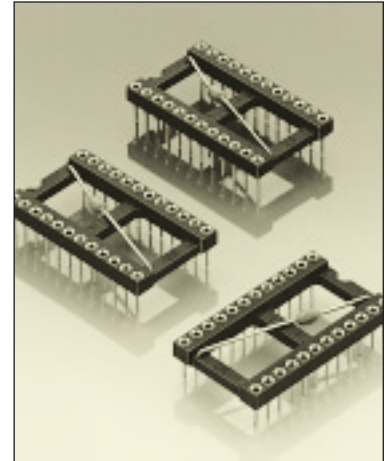

With ceramic multilayer decoupling capacitor 100 nF ± 20% / 50 V, epoxy encapsulated

Temperature range: -25°C to +85°C

Insertion characteristics: 4-finger standard



Platings	Sleeve 	Clip 	Pin 
93	5 µm Sn Pb	0.75 µm Au	

Ordering information

For standard versions see table (order codes)

Option:

3 level wrapposts (please consult)

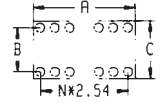
No. of poles	Order Codes					Insulator dimensions			
	Plating 93						See page 50	A	B
8	110-93-308-41-801					Fig. 4	10.1	7.62	10.1
14	110-93-314-41-801					Fig. 6	17.7	7.62	10.1
16	110-93-316-41-801					Fig. 7	20.3	7.62	10.1
18	110-93-318-41-801					Fig. 8	22.8	7.62	10.1
20	110-93-320-41-801					Fig. 9	25.3	7.62	10.1
22	110-93-322-41-801					Fig. 10	27.8	7.62	10.1
24	110-93-324-41-801					Fig. 11	30.4	7.62	10.1
22	110-93-422-41-801					Fig. 13	27.8	10.16	12.6
24	110-93-624-41-801					Fig. 17	30.4	15.24	17.7
28	110-93-628-41-801					Fig. 18	35.5	15.24	17.7
32	110-93-632-41-801					Fig. 19	40.6	15.24	17.7
40	110-93-640-41-801					Fig. 21	50.6	15.24	17.7

NEW COMPLIANT PRESS-FIT TECHNOLOGY

Based on an adaptation of the well known «eye-of-the-needle» principle, Preci-Dip's new compliant press-fit contact terminations introduce major improvements to this increasingly popular, cost-effective technology.

The solid, precision machined contacts are made of special bronze alloy, and have a very smooth surface with a homogeneous, carefully controlled tin protection. They fully comply with IEC 352 T5.

Thanks to the optimised geometry, Preci-Dip press-fit contacts offer a reduced insertion force without losing specific pressure in the contact zone, making a reliable, gas-tight connection to the PCB hole metallisation, without peeling off effect. With 1.5 mm PCB the average push-in forces are about 50 N and the average push-out forces about 45 N, both measured with a 1 mm diameter hole.

The standard contacts are available for hole diameters $1 +0.09/-0.06$ mm, and PCB thickness from 1.5 to 4.5 mm. Version for smaller holes, especially suitable for reduced pitch applications like 2 mm connectors or interstitial PGAs are now available; they fit with hole dimensions $0.9 +0.07/-0.05$ mm and $0.71 +/-0.06$ mm.

The specific manufacturing process allow us to make press-fit tails on almost all our product lines for socket contacts and pin contacts; these one are available in a selective plated version with contact body and press-fit tail tin plated and connecting pin gold plated.

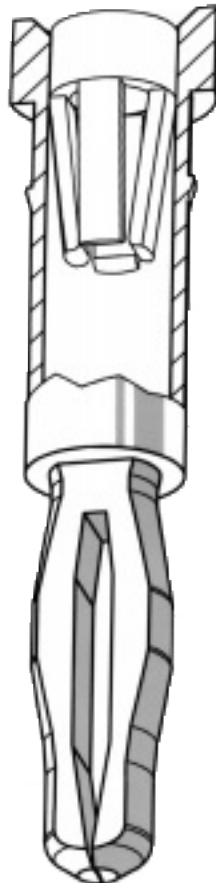

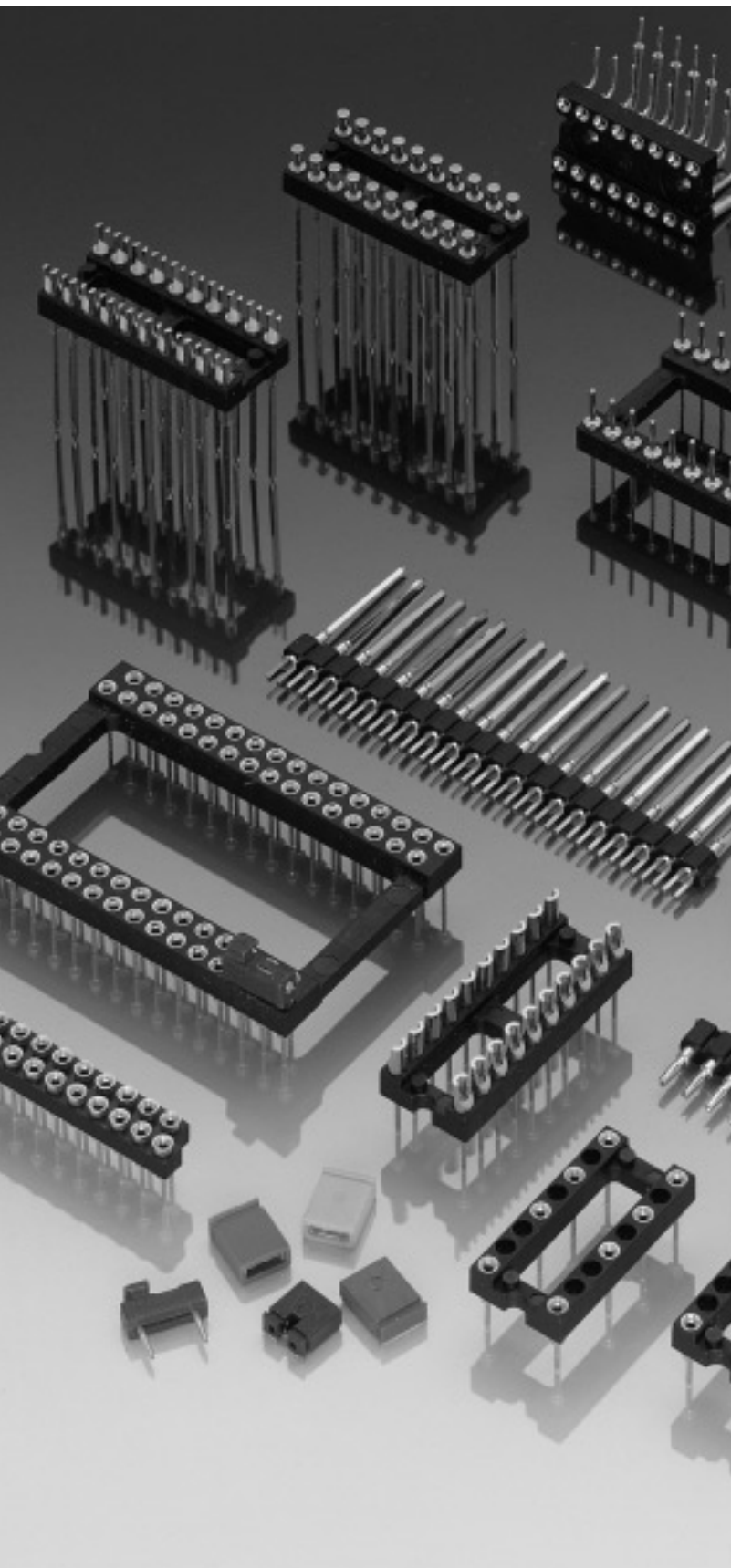

Technical specifications

Materials

- Insulator: Glass filled thermoplastic polyester, self extinguishing UL 94 V-0, colour black, resistant to mineral acids, solvents, greases, oils (short time).
- Receptacle contact:
 - Sleeve: Screw-machined brass (QQ-B-626), gold or tin-lead plated (90/10) over 2-3 μm nickel
 - Clip: Stamped beryllium-copper (QQ-C-533), gold or tin-lead (90/10) plated over 2-3 μm nickel
- Pin contact: Screw-machined brass (QQ-B-626) or phosphor bronze (QQ-B-750), gold or tin-lead plated (90/10) over 2-3 μm nickel

Mechanical data

- Insertion characteristics (measured with a polished steel gauge, typical values):
- Type of clip (finger):

	4	6
	standard	low force
- Gauge diameter (mm):

	0.43	0.46
--	------	------
- Insertion force (N):

	1.8	0.6
--	-----	-----
- Withdrawal force (N):

	0.9	0.3
--	-----	-----
- Mechanical life:

	min. 100 cycles	
--	-----------------	--

Electrical data

- Rated current: 1 A
- Rated voltage: 100 V_{RMS} / 150 V_{DC}
- Contact resistance: 10 $\text{m}\Omega$ max.
- Insulation resistance: 10 000 $\text{M}\Omega$ min.
- Dielectric strength: 1000 V_{RMS} min.
- Air and creepage distances: 0.6 mm
- Capacitance: 0.3 pF max.

Environmental data

- Operating temperature: -55/+125 $^{\circ}\text{C}$
- Vibration (10-2000 Hz, 15 g): no electrical discontinuity > 1 μs
- Shock: (50 g): no electrical discontinuity > 1 μs
- Solderability (IEC 68-2-54 Ta): 235 $^{\circ}\text{C}$, 5 s
- Resistance to soldering heat: (IEC 68-2-20 Tb): 260 $^{\circ}\text{C}$, 5 s
- Resistance to atmospheric corrosion: IEC 68-2-42 and 43
- Climatic category (IEC): 55/125/21

PRECI-DIP

DURTAL

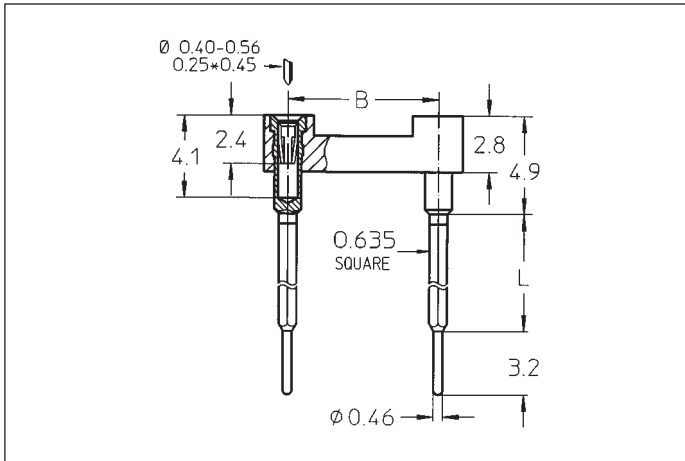



This socket is equipped with contacts combining two connection techniques: up to three-level wrapping plus PCB soldering

Also suitable for use as an interconnect socket with intermediate wire-wrap connections. Custom lengths on request

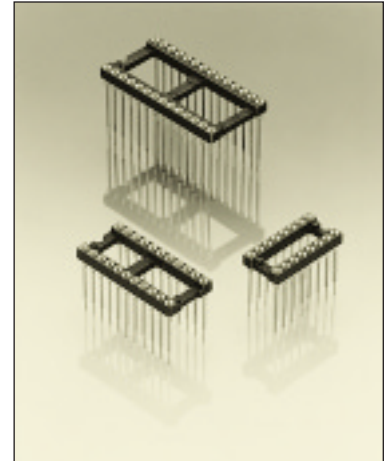
Insertion characteristics:
4-finger standard

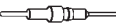

Platings	Sleeve 	Clip 	Pin 
93	5 µm Sn Pb	0.75 µm Au	

Ordering information

For complete part number see Order Codes list below

No. of poles	Order Codes			Insulator dimensions	Insulator dimensions		
	Plating 93 B	Plating 93 B	Plating 93 B		See page 50	A	B
	L = 5.9 1 Level	L = 8.9 2 Level	L = 11.9 3 Level				
10	126-93-210-41-001	126-93-210-41-002	126-93-210-41-003	Fig. 1	12.6	5.08	7.6
4	126-93-304-41-001	126-93-304-41-002	126-93-304-41-003	Fig. 2	5.0	7.62	10.1
6	126-93-306-41-001	126-93-306-41-002	126-93-306-41-003	Fig. 3	7.6	7.62	10.1
8	126-93-308-41-001	126-93-308-41-002	126-93-308-41-003	Fig. 4	10.1	7.62	10.1
10	126-93-310-41-001	126-93-310-41-002	126-93-310-41-003	Fig. 5	12.6	7.62	10.1
12	126-93-312-41-001	126-93-312-41-002	126-93-312-41-003	Fig. 5a	15.2	7.62	10.1
14	126-93-314-41-001	126-93-314-41-002	126-93-314-41-003	Fig. 6	17.7	7.62	10.1
16	126-93-316-41-001	126-93-316-41-002	126-93-316-41-003	Fig. 7	20.3	7.62	10.1
18	126-93-318-41-001	126-93-318-41-002	126-93-318-41-003	Fig. 8	22.8	7.62	10.1
20	126-93-320-41-001	126-93-320-41-002	126-93-320-41-003	Fig. 9	25.3	7.62	10.1
22	126-93-322-41-001	126-93-322-41-002	126-93-322-41-003	Fig. 10	27.8	7.62	10.1
24	126-93-324-41-001	126-93-324-41-002	126-93-324-41-003	Fig. 11	30.4	7.62	10.1
28	126-93-328-41-001	126-93-328-41-002	126-93-328-41-003	Fig. 12	35.5	7.62	10.1
20	126-93-420-41-001	126-93-420-41-002	126-93-420-41-003	Fig. 12a	25.3	10.16	12.6
22	126-93-422-41-001	126-93-422-41-002	126-93-422-41-003	Fig. 13	27.8	10.16	12.6
24	126-93-424-41-001	126-93-424-41-002	126-93-424-41-003	Fig. 14	30.4	10.16	12.6
28	126-93-428-41-001	126-93-428-41-002	126-93-428-41-003	Fig. 15	35.5	10.16	12.6
32	126-93-432-41-001	126-93-432-41-002	126-93-432-41-003	Fig. 16	40.6	10.16	12.6
10	126-93-610-41-001	126-93-610-41-002	126-93-610-41-003	Fig. 16a	12.6	15.24	17.7
24	126-93-624-41-001	126-93-624-41-002	126-93-624-41-003	Fig. 17	30.4	15.24	17.7
28	126-93-628-41-001	126-93-628-41-002	126-93-628-41-003	Fig. 18	35.5	15.24	17.7
32	126-93-632-41-001	126-93-632-41-002	126-93-632-41-003	Fig. 19	40.6	15.24	17.7
36	126-93-636-41-001	126-93-636-41-002	126-93-636-41-003	Fig. 20	45.7	15.24	17.7
40	126-93-640-41-001	126-93-640-41-002	126-93-640-41-003	Fig. 21	50.6	15.24	17.7
42	126-93-642-41-001	126-93-642-41-002	126-93-642-41-003	Fig. 22	53.2	15.24	17.7
48	126-93-648-41-001	126-93-648-41-002	126-93-648-41-003	Fig. 23	60.9	15.24	17.7
50	126-93-650-41-001	126-93-650-41-002	126-93-650-41-003	Fig. 24	63.4	15.24	17.7
52	126-93-652-41-001	126-93-652-41-002	126-93-652-41-003	Fig. 25	65.9	15.24	17.7
50	126-93-950-41-001	126-93-950-41-002	126-93-950-41-003	Fig. 26	63.4	22.86	25.3
52	126-93-952-41-001	126-93-952-41-002	126-93-952-41-003	Fig. 27	65.9	22.86	25.3
64	126-93-964-41-001	126-93-964-41-002	126-93-964-41-003	Fig. 28	81.1	22.86	25.3

Series 150 / 151

Dual-in-line pin headers

Open frame

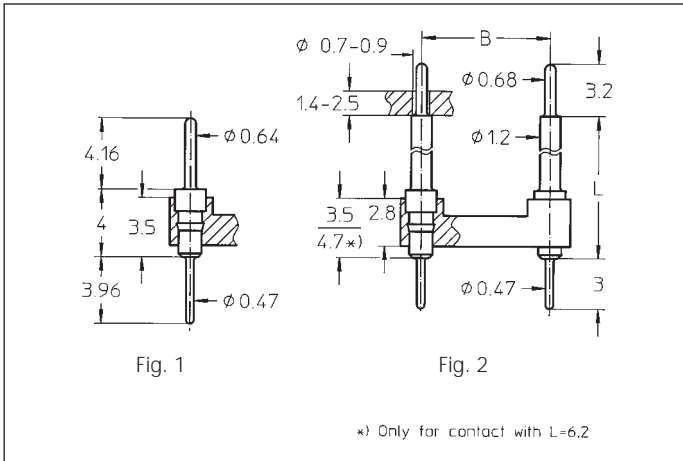

Interconnect

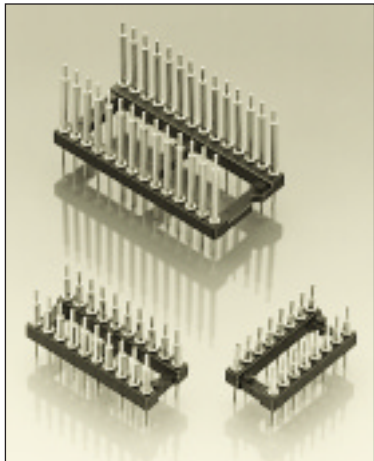

Series 15X header sockets are equipped with 0.47–0.48 mm male contacts, pluggable into standard female contacts

Sockets have 0.64–0.68 mm dia. solder pin



Platings	Sleeve 	Clip 	Pin 
10 90			0.25 µm Au 5 µm Sn Pb

Ordering information
For standard versions see table (order codes)

Option:
Pin diameter 0.47 mm at both ends available with
L = 6.2 mm: 151-xx-xxx-00-009
L = 8.4 mm: 151-xx-xxx-00-010
L = 15.3 mm: 151-xx-xxx-00-011
Plating: replace **xx** with requested plating code

No. of poles	Order Codes							Insulator dimensions	Insulator dimensions		
	Platings: see ordering information								See page 50	A	B
	Fig. 1 L = 4.0 mm	Fig. 2 L =	6.2 mm B	8.4 mm B	15.3 mm B	21.2 mm B	27.4 mm B				
10	150-xx-210-00-001	151-xx-210-00-xxx	003	004	005	016	017	Fig. 1	12.6	5.08	7.6
4	150-xx-304-00-001	151-xx-304-00-xxx	003	004	005	016	017	Fig. 2	5.0	7.62	10.1
6	150-xx-306-00-001	151-xx-306-00-xxx	003	004	005	016	017	Fig. 3	7.6	7.62	10.1
8	150-xx-308-00-001	151-xx-308-00-xxx	003	004	005	016	017	Fig. 4	10.1	7.62	10.1
10	150-xx-310-00-001	151-xx-310-00-xxx	003	004	005	016	017	Fig. 5	12.6	7.62	10.1
12	150-xx-312-00-001	151-xx-312-00-xxx	003	004	005	016	017	Fig. 5a	15.2	7.62	10.1
14	150-xx-314-00-001	151-xx-314-00-xxx	003	004	005	016	017	Fig. 6	17.7	7.62	10.1
16	150-xx-316-00-001	151-xx-316-00-xxx	003	004	005	016	017	Fig. 7	20.3	7.62	10.1
18	150-xx-318-00-001	151-xx-318-00-xxx	003	004	005	016	017	Fig. 8	22.8	7.62	10.1
20	150-xx-320-00-001	151-xx-320-00-xxx	003	004	005	016	017	Fig. 9	25.3	7.62	10.1
22	150-xx-322-00-001	151-xx-322-00-xxx	003	004	005	016	017	Fig. 10	27.8	7.62	10.1
24	150-xx-324-00-001	151-xx-324-00-xxx	003	004	005	016	017	Fig. 11	30.4	7.62	10.1
28	150-xx-328-00-001	151-xx-328-00-xxx	003	004	005	016	017	Fig. 12	35.5	7.62	10.1
20	150-xx-420-00-001	151-xx-420-00-xxx	003	004	005	016	017	Fig. 12a	25.3	10.16	12.6
22	150-xx-422-00-001	151-xx-422-00-xxx	003	004	005	016	017	Fig. 13	27.8	10.16	12.6
24	150-xx-424-00-001	151-xx-424-00-xxx	003	004	005	016	017	Fig. 14	30.4	10.16	12.6
28	150-xx-428-00-001	151-xx-428-00-xxx	003	004	005	016	017	Fig. 15	35.5	10.16	12.6
32	150-xx-432-00-001	151-xx-432-00-xxx	003	004	005	016	017	Fig. 16	40.6	10.16	12.6
10	150-xx-610-00-001	151-xx-610-00-xxx	003	004	005	016	017	Fig. 16a	12.6	15.24	17.7
24	150-xx-624-00-001	151-xx-624-00-xxx	003	004	005	016	017	Fig. 17	30.4	15.24	17.7
28	150-xx-628-00-001	151-xx-628-00-xxx	003	004	005	016	017	Fig. 18	35.5	15.24	17.7
32	150-xx-632-00-001	151-xx-632-00-xxx	003	004	005	016	017	Fig. 19	40.6	15.24	17.7
36	150-xx-636-00-001	151-xx-636-00-xxx	003	004	005	016	017	Fig. 20	45.7	15.24	17.7
40	150-xx-640-00-001	151-xx-640-00-xxx	003	004	005	016	017	Fig. 21	50.6	15.24	17.7
42	150-xx-642-00-001	151-xx-642-00-xxx	003	004	005	016	017	Fig. 22	53.2	15.24	17.7
48	150-xx-648-00-001	151-xx-648-00-xxx	003	004	005	016	017	Fig. 23	60.9	15.24	17.7
50	150-xx-650-00-001	151-xx-650-00-xxx	003	004	005	016	017	Fig. 24	63.4	15.24	17.7
52	150-xx-652-00-001	151-xx-652-00-xxx	003	004	005	016	017	Fig. 25	65.9	15.24	17.7
50	150-xx-950-00-001	151-xx-950-00-xxx	003	004	005	016	017	Fig. 26	63.4	22.86	25.3
52	150-xx-952-00-001	151-xx-952-00-xxx	003	004	005	016	017	Fig. 27	65.9	22.86	25.3
64	150-xx-964-00-001	151-xx-964-00-xxx	003	004	005	016	017	Fig. 28	81.1	22.86	25.3

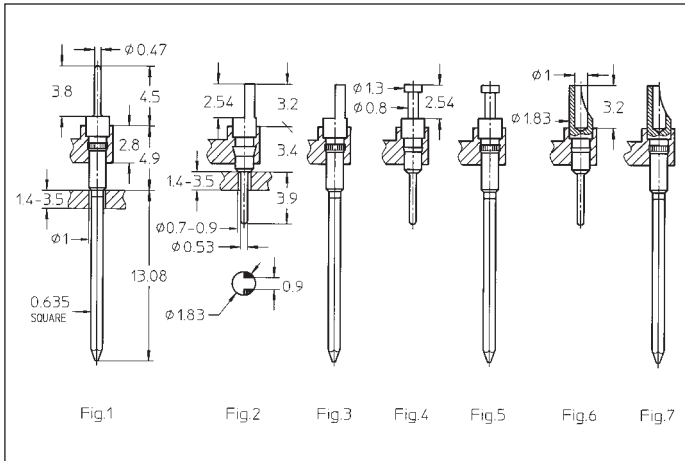

B Products not available from stock. Please consult PRECI-DIP.

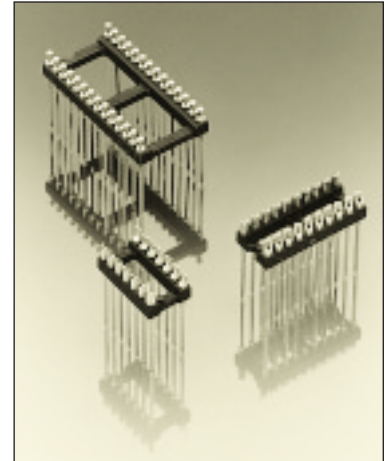

Series 153 pin headers with 3 level wrappost (Pin headers with solder tail see page 72)

Series 160 / 163 with slotted heads to accept wires or component leads, series 170 / 173 with turret heads and series 180 / 183 with solder cups for wiring applications, are with solder tail or 3 level wrappost



Platings	Sleeve 	Clip 	Pin 
10 90			0.25 µm Au 5 µm Sn Pb

Ordering information

For standard versions see table (order codes)
Platings 10 and 90 available for all versions. Replace **xx** with required plating code

Option:

2 level wrapposts (please consult)

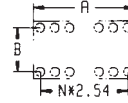
No. of poles	Order Codes								Insulator dimensions 	See page 50	A	B	C
	Fig. 1 B	Fig. 2 B	Fig. 3 B	Fig. 4 B	Fig. 5 B	Fig. 6 B	Fig. 7 B						
10	153-xx	160-xx	163-xx	170-xx	173-xx	180-xx	183-xx	-210-00-001	Fig. 1	12.6	5.08	7.6	
4	153-xx	160-xx	163-xx	170-xx	173-xx	180-xx	183-xx	-304-00-001	Fig. 2	5.0	7.62	10.1	
6	153-xx	160-xx	163-xx	170-xx	173-xx	180-xx	183-xx	-306-00-001	Fig. 3	7.6	7.62	10.1	
8	153-xx	160-xx	163-xx	170-xx	173-xx	180-xx	183-xx	-308-00-001	Fig. 4	10.1	7.62	10.1	
10	153-xx	160-xx	163-xx	170-xx	173-xx	180-xx	183-xx	-310-00-001	Fig. 5	12.6	7.62	10.1	
12	153-xx	160-xx	163-xx	170-xx	173-xx	180-xx	183-xx	-312-00-001	Fig. 5a	15.2	7.62	10.1	
14	153-xx	160-xx	163-xx	170-xx	173-xx	180-xx	183-xx	-314-00-001	Fig. 6	17.7	7.62	10.1	
16	153-xx	160-xx	163-xx	170-xx	173-xx	180-xx	183-xx	-316-00-001	Fig. 7	20.3	7.62	10.1	
18	153-xx	160-xx	163-xx	170-xx	173-xx	180-xx	183-xx	-318-00-001	Fig. 8	22.8	7.62	10.1	
20	153-xx	160-xx	163-xx	170-xx	173-xx	180-xx	183-xx	-320-00-001	Fig. 9	25.3	7.62	10.1	
22	153-xx	160-xx	163-xx	170-xx	173-xx	180-xx	183-xx	-322-00-001	Fig. 10	27.8	7.62	10.1	
24	153-xx	160-xx	163-xx	170-xx	173-xx	180-xx	183-xx	-324-00-001	Fig. 11	30.4	7.62	10.1	
28	153-xx	160-xx	163-xx	170-xx	173-xx	180-xx	183-xx	-328-00-001	Fig. 12	35.5	7.62	10.1	
20	153-xx	160-xx	163-xx	170-xx	173-xx	180-xx	183-xx	-420-00-001	Fig. 12a	25.3	10.16	12.6	
22	153-xx	160-xx	163-xx	170-xx	173-xx	180-xx	183-xx	-422-00-001	Fig. 13	27.8	10.16	12.6	
24	153-xx	160-xx	163-xx	170-xx	173-xx	180-xx	183-xx	-424-00-001	Fig. 14	30.4	10.16	12.6	
28	153-xx	160-xx	163-xx	170-xx	173-xx	180-xx	183-xx	-428-00-001	Fig. 15	35.5	10.16	12.6	
32	153-xx	160-xx	163-xx	170-xx	173-xx	180-xx	183-xx	-432-00-001	Fig. 16	40.6	10.16	12.6	
10	153-xx	160-xx	163-xx	170-xx	173-xx	180-xx	183-xx	-610-00-001	Fig. 16a	12.6	15.24	17.7	
24	153-xx	160-xx	163-xx	170-xx	173-xx	180-xx	183-xx	-624-00-001	Fig. 17	30.4	15.24	17.7	
28	153-xx	160-xx	163-xx	170-xx	173-xx	180-xx	183-xx	-628-00-001	Fig. 18	35.5	15.24	17.7	
32	153-xx	160-xx	163-xx	170-xx	173-xx	180-xx	183-xx	-632-00-001	Fig. 19	40.6	15.24	17.7	
36	153-xx	160-xx	163-xx	170-xx	173-xx	180-xx	183-xx	-636-00-001	Fig. 20	45.7	15.24	17.7	
40	153-xx	160-xx	163-xx	170-xx	173-xx	180-xx	183-xx	-640-00-001	Fig. 21	50.6	15.24	17.7	
42	153-xx	160-xx	163-xx	170-xx	173-xx	180-xx	183-xx	-642-00-001	Fig. 22	53.2	15.24	17.7	
48	153-xx	160-xx	163-xx	170-xx	173-xx	180-xx	183-xx	-648-00-001	Fig. 23	60.9	15.24	17.7	
50	153-xx	160-xx	163-xx	170-xx	173-xx	180-xx	183-xx	-650-00-001	Fig. 24	63.4	15.24	17.7	
52	153-xx	160-xx	163-xx	170-xx	173-xx	180-xx	183-xx	-652-00-001	Fig. 25	65.9	15.24	17.7	
50	153-xx	160-xx	163-xx	170-xx	173-xx	180-xx	183-xx	-950-00-001	Fig. 26	63.4	22.86	25.3	
52	153-xx	160-xx	163-xx	170-xx	173-xx	180-xx	183-xx	-952-00-001	Fig. 27	65.9	22.86	25.3	
64	153-xx	160-xx	163-xx	170-xx	173-xx	180-xx	183-xx	-964-00-001	Fig. 28	81.1	22.86	25.3	

Series 353–383 / 453–483

PCB Header Strips
Single row / double row
Wire-wrap / solder tail

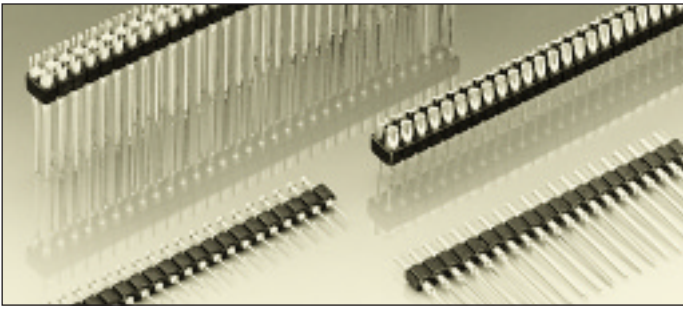



Headers

With pin / slotted / turret / solder cup head

Solder tail or wrapost

Solder tail pin \varnothing 0.53 mm

Wrapost termination \square 0.63 square

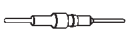
Platings	Sleeve 	Clip 	Pin 
10 90			0.25 μ m Au 5 μ m Sn Pb

Ordering information

Replace **xx** with the number of poles. e.g. 460-10-2**xx**-00-001 for a double row version with 8 pins per row becomes: 460-10-2**16**-00-001

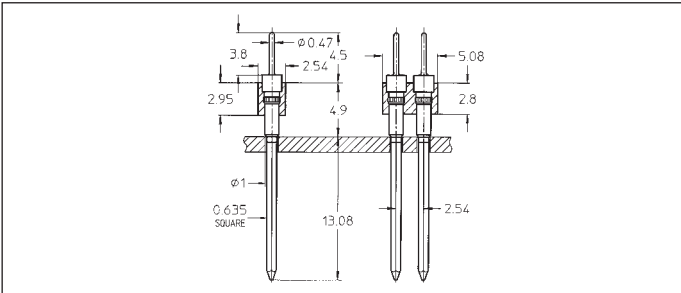

353-10-1xx-00-001 **B**

353-90-1xx-00-001

453-10-2xx-00-001 **B**

453-90-2xx-00-001

Pin header strip, wrapost, single row / double row. Solder tail see page 44

Single row, availability from: 1 to 64 contacts
Standard number of contacts 5, 6, 8, 10, 14, 16, 20, 21, 25, 30, 32, 48, 56, 60 and 64

Double row, availability from 4 to 72 contacts
Standard number of contacts 40, 44, 56, 64 and 72

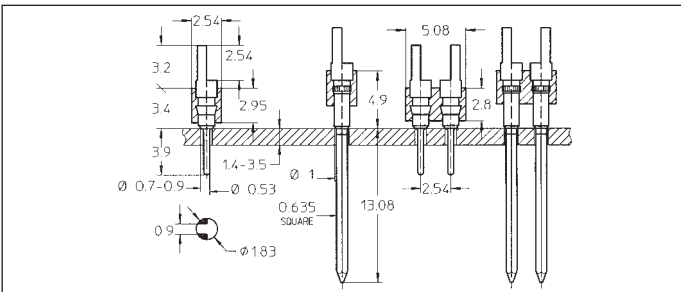

360-10-1xx-00-001 **B**

360-90-1xx-00-001

363-10-1xx-00-001 **B**

363-90-1xx-00-001

460-10-2xx-00-001 **B**

460-90-2xx-00-001

463-10-2xx-00-001 **B**

463-90-2xx-00-001

Slotted head strip, solder tail or wrapost, single row / double row

Single row, availability from: 1 to 64 contacts
Standard number of contacts 5, 6, 8, 10, 14, 16, 20, 21, 25, 30, 32, 48, 56, 60 and 64

Double row, availability from 4 to 72 contacts
Standard number of contacts 40, 44, 56, 64 and 72

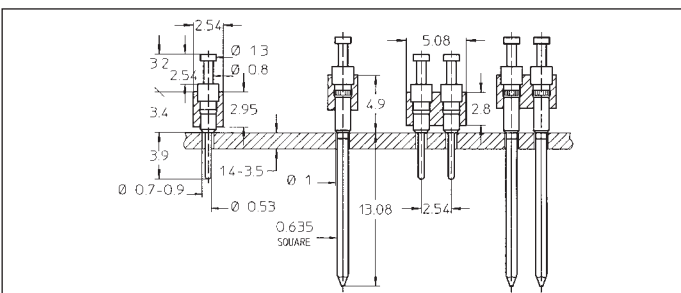

370-10-1xx-00-001 **B**

370-90-1xx-00-001

373-10-1xx-00-001 **B**

373-90-1xx-00-001

470-10-2xx-00-001 **B**

470-90-2xx-00-001

473-10-2xx-00-001 **B**

473-90-2xx-00-001

Turret head strip, solder tail or wrapost, single row / double row

Single row, availability from: 1 to 64 contacts
Standard number of contacts 5, 6, 8, 10, 14, 16, 20, 21, 25, 30, 32, 48, 56, 60 and 64

Double row, availability from 4 to 72 contacts
Standard number of contacts 40, 44, 56, 64 and 72

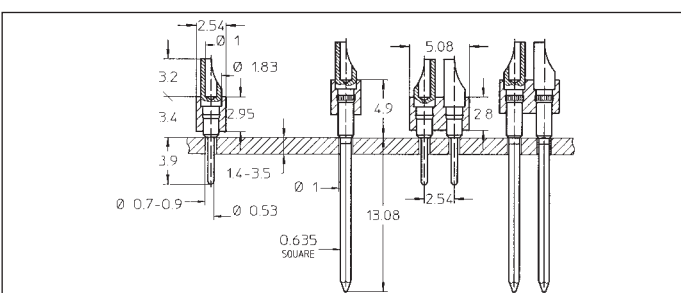

380-10-1xx-00-001 **B**

380-90-1xx-00-001

383-10-1xx-00-001 **B**

383-90-1xx-00-001

480-10-2xx-00-001 **B**

480-90-2xx-00-001

483-10-2xx-00-001 **B**

483-90-2xx-00-001

Solder cup strip, solder tail or wrapost, single row / double row

Single row, availability from: 1 to 64 contacts
Standard number of contacts 5, 6, 8, 10, 14, 16, 20, 21, 25, 30, 32, 48, 56, 60 and 64

Double row, availability from 4 to 72 contacts
Standard number of contacts 40, 44, 56, 64 and 72

Series 299

Dual-in-line sockets / right angle version

Closed frame

Solder tail

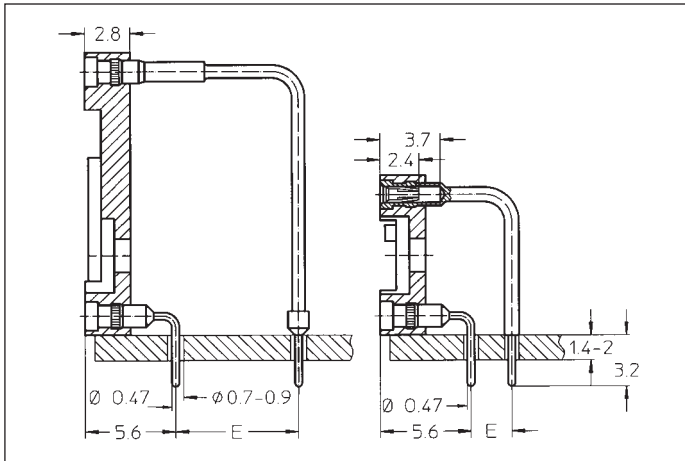



Series 299 DIL sockets with closed frame insulator are designed for components to be mounted perpendicularly to the PCB, such as LED displays

Right angle solder-tails are available with either 7.62 mm (standard) or 2.54 mm row spacing

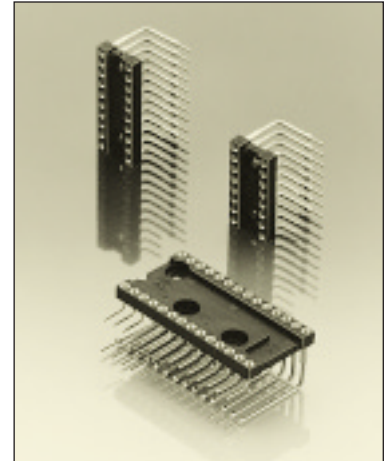
Insertion characteristics:
4-finger standard



Platings	Sleeve 	Clip 	Pin 
93 91	5 µm Sn Pb 5 µm Sn Pb	0.75 µm Au 0.25 µm Au	

Ordering information

For complete part number see Order Codes list below

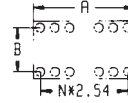

No. of poles	Order Codes				Insulator dimensions			
	Plating 93 B	Plating 93 B	Plating 91 B	Plating 91 B		See page 51	A	B
	E = 7.62	E = 2.54	E = 7.62	E = 2.54				
6	299-93-306-10-001	299-93-306-11-001	299-91-306-10-001	299-91-306-11-001		7.6	7.62	10.1
8	299-93-308-10-001	299-93-308-11-001	299-91-308-10-001	299-91-308-11-001		10.1	7.62	10.1
10	299-93-310-10-001	299-93-310-11-001	299-91-310-10-001	299-91-310-11-001		12.6	7.62	10.1
12	299-93-312-10-001	299-93-312-11-001	299-91-312-10-001	299-91-312-11-001		15.2	7.62	10.1
14	299-93-314-10-001	299-93-314-11-001	299-91-314-10-001	299-91-314-11-001		17.7	7.62	10.1
16	299-93-316-10-001	299-93-316-11-001	299-91-316-10-001	299-91-316-11-001		20.3	7.62	10.1
18	299-93-318-10-001	299-93-318-11-001	299-91-318-10-001	299-91-318-11-001		22.8	7.62	10.1
20	299-93-320-10-001	299-93-320-11-001	299-91-320-10-001	299-91-320-11-001		25.3	7.62	10.1
24	299-93-324-10-001	299-93-324-11-001	299-91-324-10-001	299-91-324-11-001		30.4	7.62	10.1
8	299-93-608-10-002		299-91-608-10-002			10.1	15.24	17.7
10	299-93-610-10-002		299-91-610-10-002			12.6	15.24	17.7
12	299-93-612-10-002		299-91-612-10-002			15.2	15.24	17.7
14	299-93-614-10-002		299-91-614-10-002			17.7	15.24	17.7
16	299-93-616-10-002		299-91-616-10-002			20.1	15.24	17.7
18	299-93-618-10-002		299-91-618-10-002			22.8	15.24	17.7
20	299-93-620-10-002		299-91-620-10-002			25.3	15.24	17.7
22	299-93-622-10-002		299-91-622-10-002			27.8	15.24	17.7
24	299-93-624-10-002		299-91-624-10-002			30.4	15.24	17.7
26	299-93-626-10-002		299-91-626-10-002			33.0	15.24	17.7
28	299-93-628-10-002		299-91-628-10-002			35.5	15.24	17.7
30	299-93-630-10-002		299-91-630-10-002			38.0	15.24	17.7
32	299-93-632-10-002		299-91-632-10-002			40.6	15.24	17.7
36	299-93-636-10-002		299-91-636-10-002			45.7	15.24	17.7
40	299-93-640-10-002		299-91-640-10-002			50.6	15.24	17.7

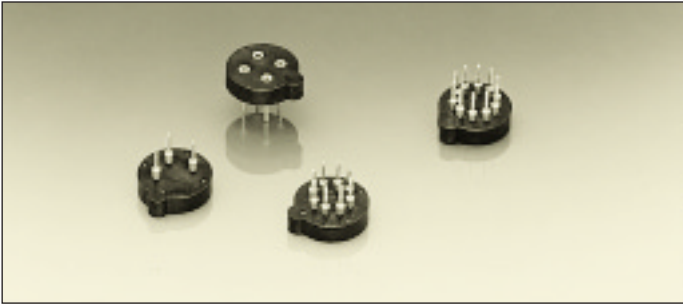
Series 917
TO sockets
Solder tail



Series 917 TO package sockets exist with 3, 4, 8 and 10 contacts. Two 8 pin versions feature pin centers either on a 5.08 mm or a 5.84 mm circle

Insertion characteristics:
4-finger standard

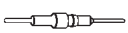
Platings	Sleeve 	Clip 	Pin 
91 B	5 µm Sn Pb	0.25 µm Au	
93	5 µm Sn Pb	0.75 µm Au	
97 B	5 µm Sn Pb	Goldflash	
99 B	5 µm Sn Pb	5 µm Sn Pb	

Ordering information

Replace **xx** with code of required plating, e.g.
917-xx-103-41-005 becomes: 917-**99**-103-41-005 with 5 µm tin on sleeve and clip

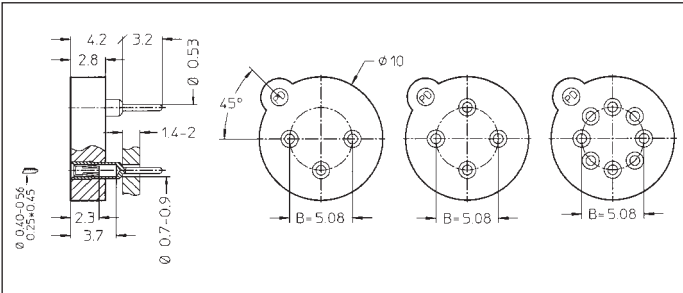

- 917-xx-103-41-005
- 917-xx-104-41-005
- 917-xx-108-41-005

Series 917 sockets for TO 5 package
Contacts arranged on 5.08 mm circle diameter

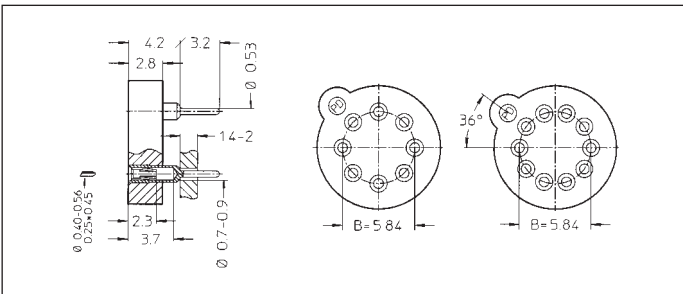

- 917-xx-208-41-005
- 917-xx-210-41-005



Series 917 sockets for TO 100 package
Contacts arranged on 5.84 mm circle diameter



Series 999 jumpers are available

With insulators in various colors for easier identification

Male version will fit standard receptacles; female version with open or closed body fits square pin headers

Platings	Sleeve 	Clip 	Pin 
19 39 90			0.25 μm Au* 0.75 μm Au* 5 μm Sn Pb * selective

Ordering information

Replace **xx** with required plating code
Applies to jumpers for square pin headers only

Option:

Wire dia 0.50 mm instead of 0.56 mm. Change second group of figures into 51. Example: 999-11-113-10 becomes 999-**51**-113-10. (Applies only to jumpers for receptacle connectors without insulator)

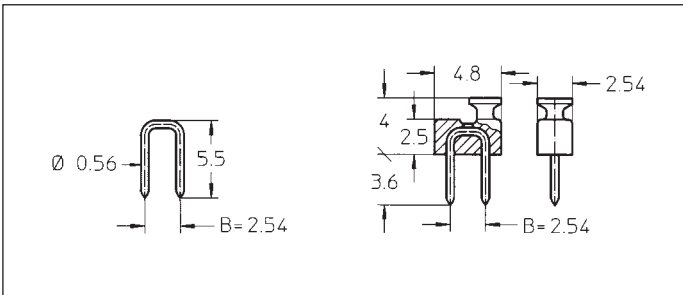

Platings:
0.25 μm Au 5 μm Sn Pb

999-11-110-10	999-11-110-90
999-11-210-10	999-11-210-90
999-11-210-11	999-11-210-91

Jumpers for receptacle connectors. B = 2.54 mm

Insulator:
none
black
red

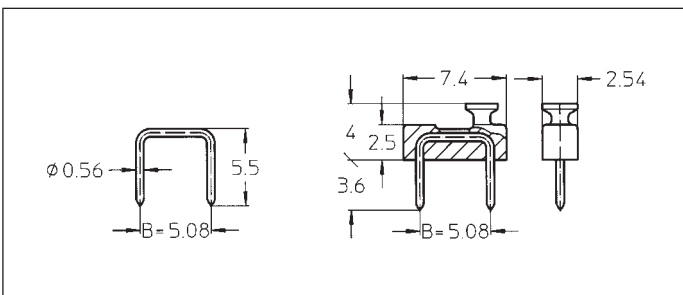

Platings:
0.25 μm Au 5 μm Sn Pb

999-11-112-10	999-11-112-90
999-11-220-10	999-11-220-90
999-11-220-11	999-11-220-91

Jumpers for receptacle connectors. B = 5.08 mm

Insulator:
none
black
red

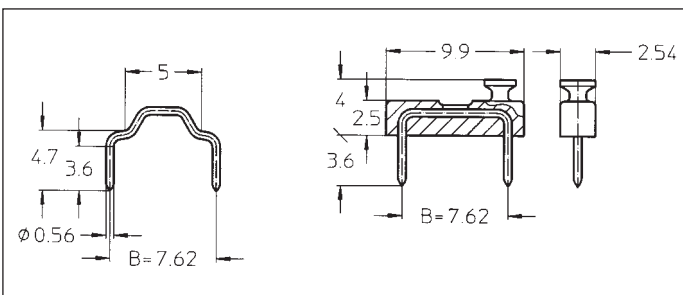

Platings:
0.25 μm Au 5 μm Sn Pb

999-11-113-10	999-11-113-90
999-11-230-10	999-11-230-90
999-11-230-11	999-11-230-91

Jumpers for receptacle connectors. B = 7.62 mm

Insulator:
none
black
red

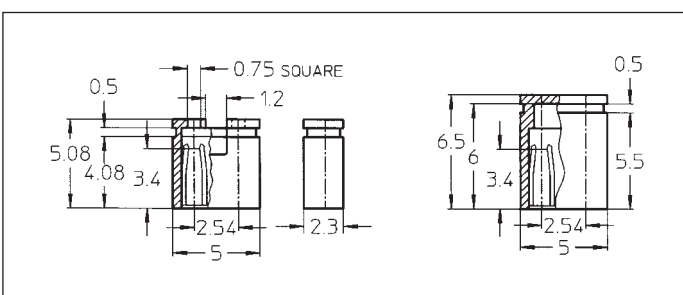

Body style
Open body Closed body

999-xx-310-00	999-xx-210-00
999-xx-310-02	999-xx-210-02
999-xx-310-06	999-xx-210-06

Female jumpers for 2.54 mm square pin headers:

black
red
blue

NEW ADAPTER SOCKET FOR BGA COMPONENTS

The new BGA (Ball Grid Array) technology was designed for high pin count packages and direct SMT assembly on the PCB. BGA components have small tin balls instead of soldering pins and are thus suitable for direct reflow soldering on SMT circuit boards.

The contacts are arranged in a grid pattern with a pitch of 1.5 mm or 1.27 mm.

This type of package allows cost and dimensional reductions, but there is a soldering problem as connections in the center of the array cannot be inspected visually.

The new adapter under design at Preci-Dip consists of two parts:

1. the socket: standard type PGA socket with female contacts for soldering or SMT connections.
2. the carrier: has metal pad on one side for SMT soldering of the BGA component. On the other side male contacts allow plugging in the socket.

The design of the insulator body is adapted to the use of automatic or manual insertion/extraction equipment. Orientation and/or position marks required by automatic equipment available on request.

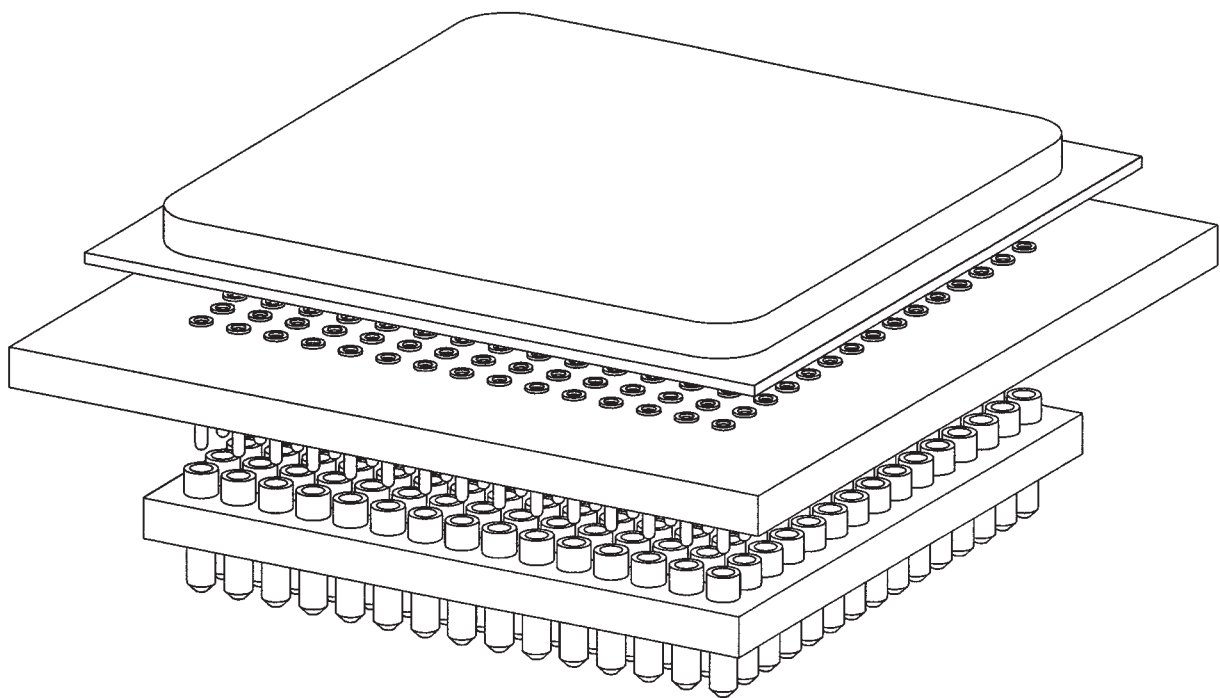

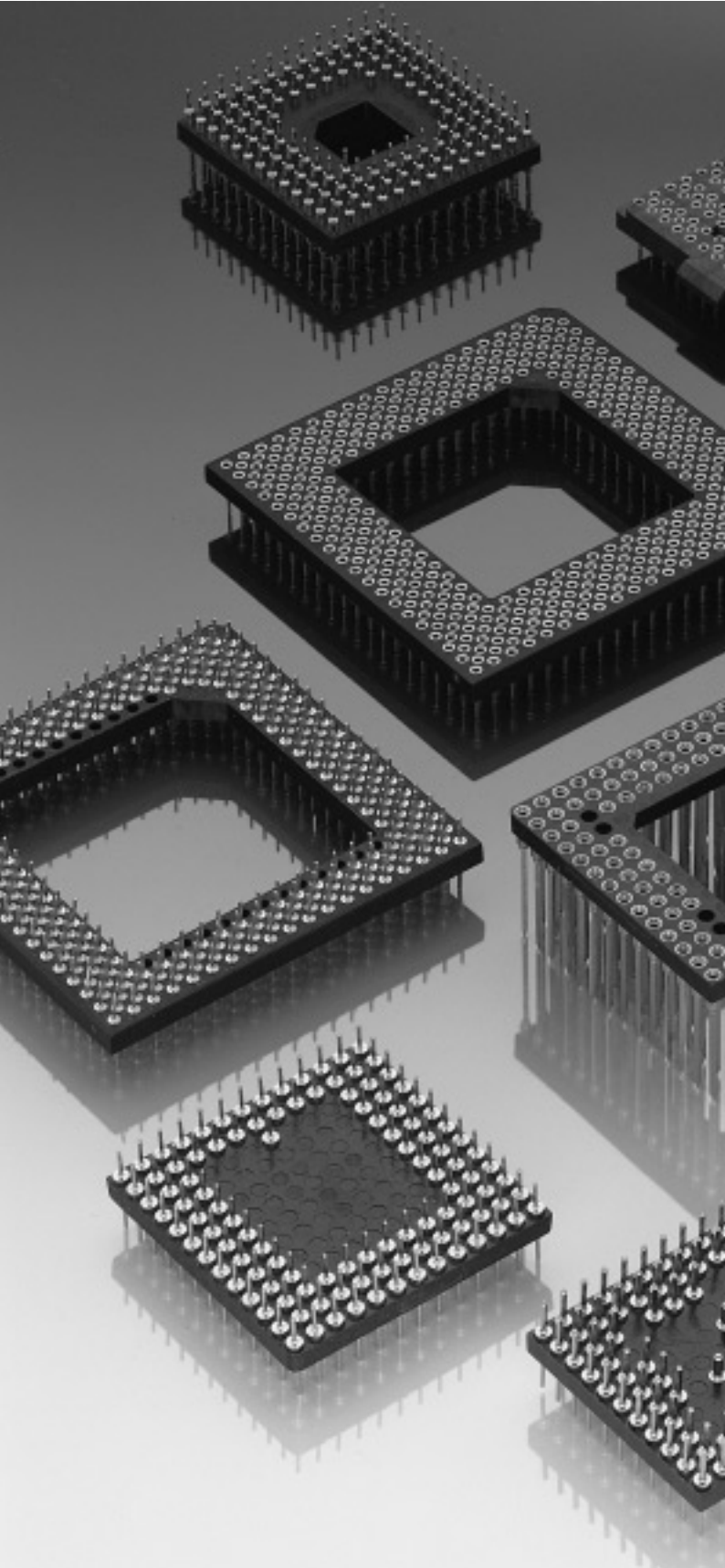

Technical specifications

Materials

- Insulator: Glass filled thermoplastic polyester, self extinguishing UL 94 V-0, colour black, resistant to mineral acids, solvents, greases, oils (short time).
- Receptacle contact:
 - Sleeve: Screw-machined brass (QQ-B-626), gold or tin-lead plated (90/10) over 2–3 μm nickel
 - Clip: Stamped beryllium-copper (QQ-C-533), gold or tin-lead (90/10) plated over 2–3 μm nickel
- Pin contact: Screw-machined brass (QQ-B-626) or phosphor bronze (QQ-B-750), gold or tin-lead plated (90/10) over 2–3 μm nickel

Mechanical data

- Insertion characteristics (measured with a polished steel gauge, typical values):

– Type of clip (finger):	6	6	6	3*
– Insertion characteristics:	low	very low	ultra low	low
– Gauge diameter (mm):	0.46	0.46	0.46	0.46
– Insertion force (N):	0.6	0.35	0.20	0.7
– Withdrawal force (N):	0.3	0.20	0.10	0.3
– Mechanical life:	min. 100 cycles			* Series 614 only

Electrical data

- Rated current: 1 A
- Rated voltage: 100 V_{RMS} / 150 V_{DC}
- Contact resistance: 10 $\text{m}\Omega$ max.
- Insulation resistance: 10 000 $\text{M}\Omega$ min.
- Dielectric strength: 1000 V_{RMS} min. (700 for Series 517 Interstitial PGA)
- Air and creepage distances: 0.6 mm (0.3 for Series 517)
- Capacitance: 0.3 pF max. (1 for series 517)

Environmental data

- Operating temperature: $-55/+125^\circ\text{C}$
- Vibration (10–2000 Hz, 15 g): no electrical discontinuity > 1 μs
- Shock: (50 g): no electrical discontinuity > 1 μs
- Solderability (IEC 68-2-54 Ta): 235 $^\circ\text{C}$, 5 s
- Resistance to soldering heat: 260 $^\circ\text{C}$, 10 s (IEC 68-2-20 Tb)
- Atmospheric corrosion: IEC 68-2-42 and 43
- Climatic category (IEC): 55/125/21

Dimensional data

Calculate with n_1 = number of contacts in one line ($5 \leq n_1 \leq 21$) and n_2 = characteristic size of the window ($3 \leq n_2 \leq 10$) for polyester bodies

$$A = n_1 \times 2.54$$

$$B = (n_1 - 1) \times 2.54$$

$$C = (n_2 \times 2.54) - 0.40$$

for glass-epoxy bodies

$$A = n_1 \times 2.54 + 1.27$$

$$B = (n_1 - 1) \times 2.54$$

$$C = (n_2 \times 2.54) - 0.40$$

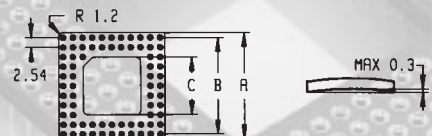

PRECI-DIP

DURTAL

Series 510 / 511 / 515

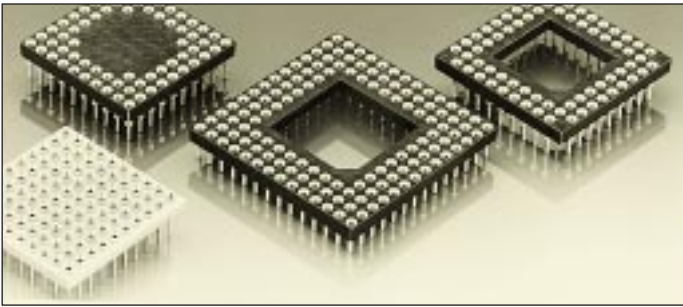

Pin grid array sockets Solder tail



Pin grid array sockets, standard solder version

PGA sockets are high density connecting devices equipped with machined precision contacts with soft contact clips assuring low insertion/withdrawal forces. Over 200 standard pinouts are available; inquiries for custom varieties are welcome

Insertion characteristics: 6-finger low, very low or ultra low force

Platings	Sleeve 	Clip 	Pin 
13	0.25 µm Au	0.75 µm Au	
91	5.0 µm Sn	0.25 µm Au	
93	5.0 µm Sn	0.75 µm Au	
97	5.0 µm Sn	Goldflash	
99	5.0 µm Sn	5.0 µm Sn	

Ordering information

Replace **xxx-xx-xxx** with the number of poles, body size and layout numbers as indicated on pages 88 to 92. For example, a 12x12 pin configuration with window and 108 standard soldering contacts as shown on page 88 becomes: 510-93-**108-12-051**-001

Machined epoxy insulator for extra sturdiness and low profile applications; solder and wire-wrap terminations only; please consult for availability and specifications

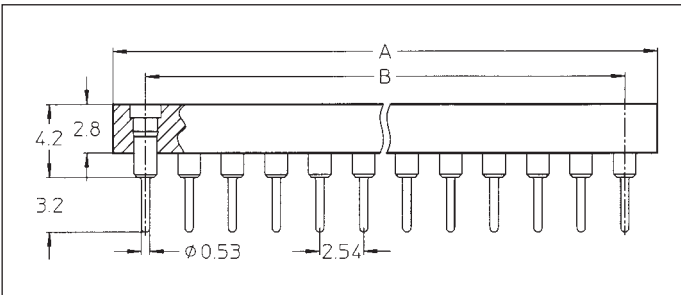

510-13-xxx-xx-xxx-001 **B**

510-91-xxx-xx-xxx-001

510-93-xxx-xx-xxx-001

510-97-xxx-xx-xxx-001

510-99-xxx-xx-xxx-001

510-93Bxxx-xx-xxx-001 **B**

510-97Bxxx-xx-xxx-001 **B**

510-93Cxxx-xx-xxx-001 **B**

510-97Cxxx-xx-xxx-001 **B**

PGA sockets with standard solder tails, length 3.2 mm

Option: **B**

PGA sockets with optional stand-offs, please consult for availability

Option: **B**

PGA sockets with standard solder tail length 3.2 mm and very low force (B) or ultra low force (C) clips

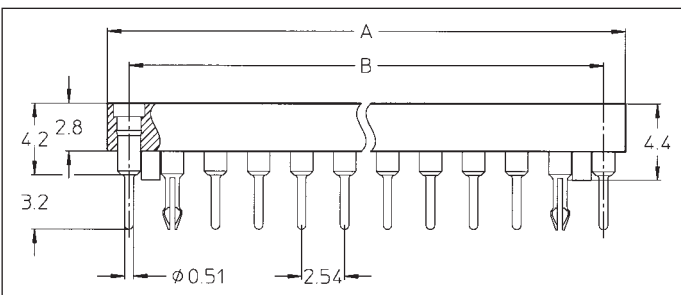

510-13-xxx-xx-xxx-001 **B**

510-91-xxx-xx-xxx-001 **B**

510-93-xxx-xx-xxx-001 **B**

510-97-xxx-xx-xxx-001 **B**

510-99-xxx-xx-xxx-001 **B**

Option: **B**

PGA sockets with standard solder tails, length 3.2 mm, four optional self-clinching snap-in pins, and four optional stand-offs.

Add **70** to fourth group of figures in standard reference number, e.g. 510-93-108-12-051-001 becomes: 510-93-108-**82**-051-001

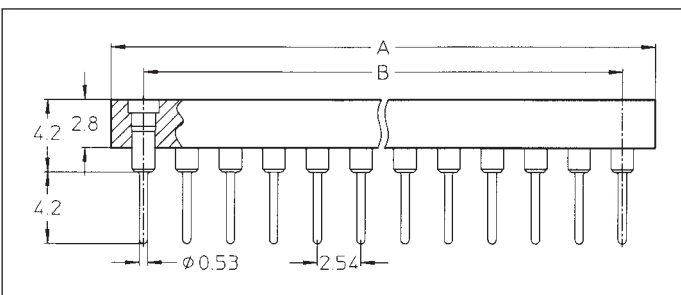

511-13-xxx-xx-xxx-001 **B**

511-91-xxx-xx-xxx-001 **B**

511-93-xxx-xx-xxx-001 **B**

511-97-xxx-xx-xxx-001 **B**

511-99-xxx-xx-xxx-001 **B**

PGA sockets with standard solder tails, length 4.2 mm

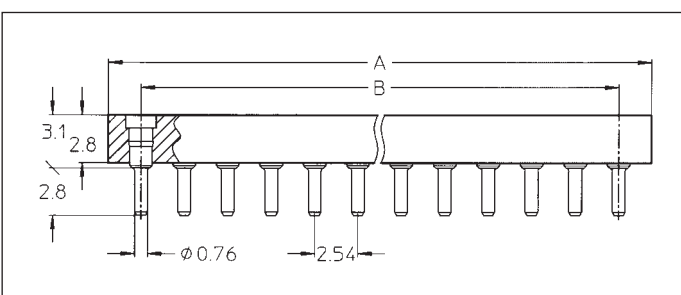

515-13-xxx-xx-xxx-001 **B**

515-91-xxx-xx-xxx-001

515-93-xxx-xx-xxx-001

515-97-xxx-xx-xxx-001

515-99-xxx-xx-xxx-001

PGA sockets with low profile contacts and solder tails of 2.8 mm length

PGA sockets with ultra low profile contacts please consult

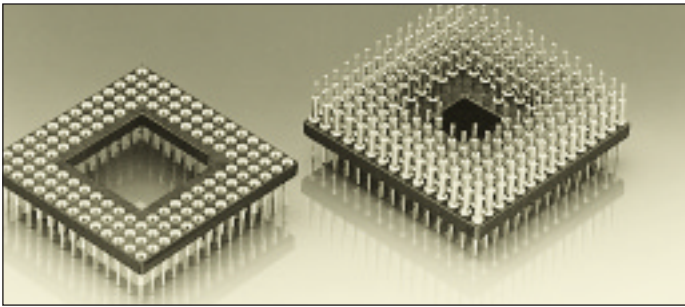



Pin grid array sockets, interconnect receptacle and pin, solder tail, receptacle with wire-wrap posts

Series 516, 521, 522, 523, 550 and 551 PGA sockets are high density connecting devices equipped with machined precision male or female contacts.

Receptacles have soft contact clips assuring low insertion/withdrawal forces. Over 200 standard pinouts are available; inquiries for custom varieties are welcome

Insertion characteristics: receptacle 6-finger low force

Platings	Sleeve 	Clip 	Pin 
10 13 90	0.25 µm Au	0.75 µm Au	0.25 µm Au
91 93 97 99	5.0 µm Sn Pb 5.0 µm Sn Pb 5.0 µm Sn Pb 5.0 µm Sn Pb	0.25 µm Au 0.75 µm Au Goldflash 5.0 µm Sn Pb	5.0 µm Sn Pb

Ordering information

Replace **xxx-xx-xxx** with the number of poles, body size and layout numbers as indicated on pages 88 to 92. For example, a 12x12 pin configuration with window and 108 interconnect contacts as shown on page 88 becomes: 516-93-**108-12-051**-003 or 551-90-**108-12-051**-003

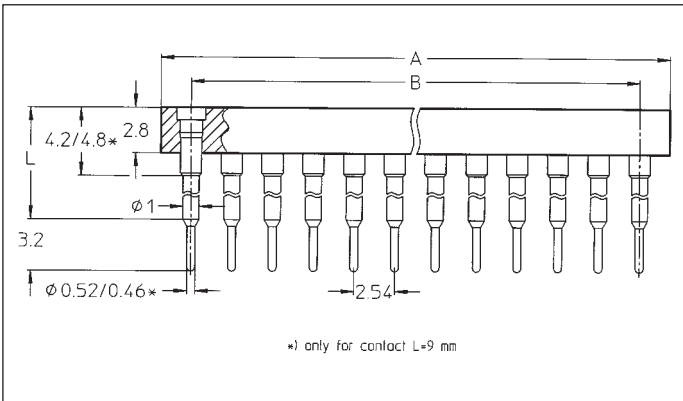

	L =
516-93-xxx-xx-xxx-006	6 B
516-93-xxx-xx-xxx-003	8 B
516-93-xxx-xx-xxx-012	9 B
516-93-xxx-xx-xxx-007	10 B
516-93-xxx-xx-xxx-008	12 B
516-93-xxx-xx-xxx-009	13 B
516-93-xxx-xx-xxx-001	15 B
516-93-xxx-xx-xxx-011	18 B
516-93-xxx-xx-xxx-004	22 B
516-93-xxx-xx-xxx-013	33 B

PGA interconnect sockets; solder tail

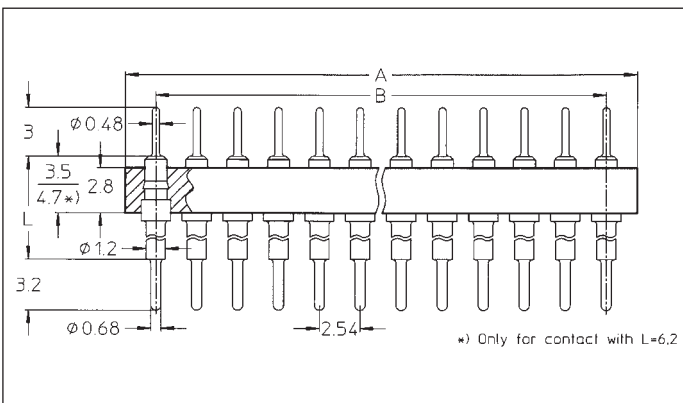

	L =
550-10-xxx-xx-xxx-001	4.0 mm
550-90-xxx-xx-xxx-001	
551-10-xxx-xx-xxx-003	6.2 mm B
551-90-xxx-xx-xxx-003	
551-10-xxx-xx-xxx-004	8.4 mm B
551-90-xxx-xx-xxx-004	
551-10-xxx-xx-xxx-005	15.3 mm B
551-90-xxx-xx-xxx-005	
551-10-xxx-xx-xxx-016	21.2 mm B
551-90-xxx-xx-xxx-016	
551-10-xxx-xx-xxx-017	27.4 mm B
551-90-xxx-xx-xxx-017	

PGA interconnect sockets; solder tail

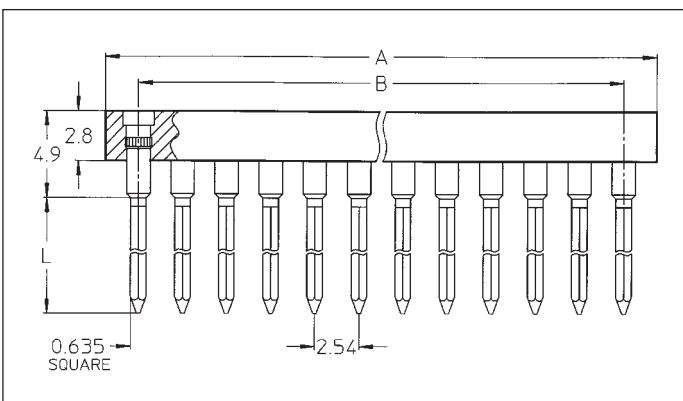

52x-13-xxx-xx-xxx-001	B
52x-91-xxx-xx-xxx-001	B
52x-93-xxx-xx-xxx-001	B
52x-97-xxx-xx-xxx-001	B
52x-99-xxx-xx-xxx-001	B

1 level L = 6.60 mm = 521-...
2 level L = 9.40 mm = 522-...
3 level L = 12.95 mm = 523-...

PGA sockets with wire-wrap terminations

Dimensions of wrapost 0.635 square

Series 517 / 614

Pin grid array sockets and carrier with interstitial contact rows Solder tail

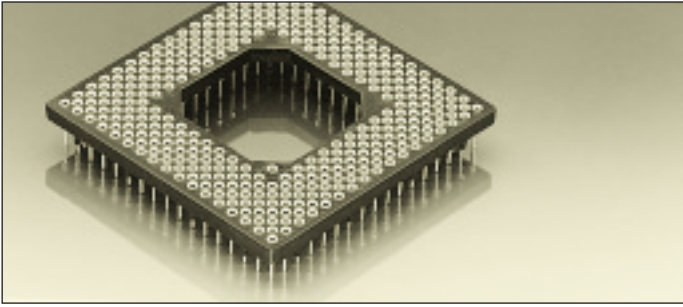



Pin grid array sockets with interstitial contact rows

These sockets of a very compact design have interstitial contact rows with a staggered contact arrangement and row distances of 1.27 mm. Their contact density is nearly double as compared to PGAs based on a standard 2.54 mm grid pattern

They are equipped with machined precision contacts with extra-soft contact clips assuring low insertion/withdrawal forces

Insertion characteristics: 6-finger very low

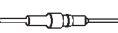
Platings	Sleeve 	Clip 	Pin 
91	5 µm Sn	0.25 µm Au	
93	5 µm Sn	0.75 µm Au	
97	5 µm Sn	Goldflash	

Ordering information

Replace **xxx-xx-xxx** with number of poles, body size and layout numbers as indicated on pages 91 and 92. For example, a 18x18 pin configuration with 17x17 interstitial rows and standard soldering tails becomes: 517-93-**391-18-101111**

Options:

For other sizes and layouts please consult

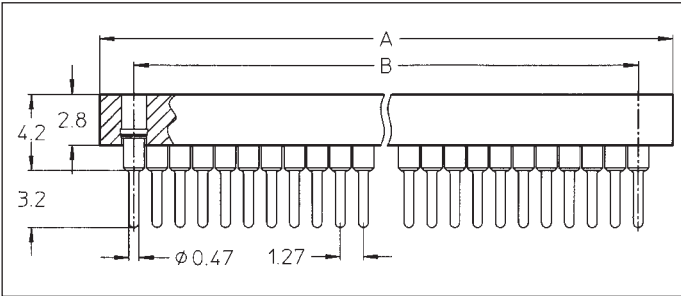

517-91-xxx-xx-xxx-111

517-93-xxx-xx-xxx-111

517-97-xxx-xx-xxx-111 **B**

PGA sockets with interstitial rows and standard solder tails, length 3.2 mm

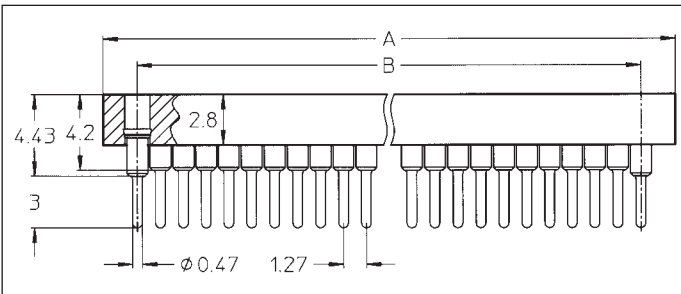

517-91-xxx-xx-xxx-111 **B**

517-93-xxx-xx-xxx-111 **B**

517-97-xxx-xx-xxx-111 **B**

Interstitial PGA socket with standard solder tails and 4 elevating contacts located at the corners for better soldering and cleaning

Add 50 to the fourth group of figures in standard reference number, e.g. 517-93-391-18-101111 becomes 517-93-391-68-101111

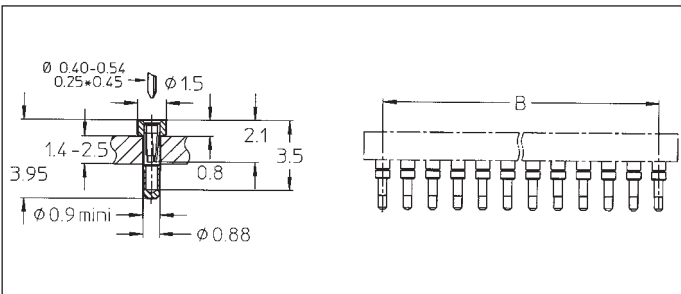

614-91-xxx-xx-xxx-144 **B**

614-93-xxx-xx-xxx-144 **B**

614-97-xxx-xx-xxx-144 **B**

PGA carrier socket with disposable plastic body and carrier pins. Low profile ultra thin contacts are plugged-on

Solder terminations Ø 0.88 mm total length of contact 3.9 mm Requires Ø min. 0.9 mm holes in PCB

Series 546 Pin Grid Array sockets Press-fit terminations

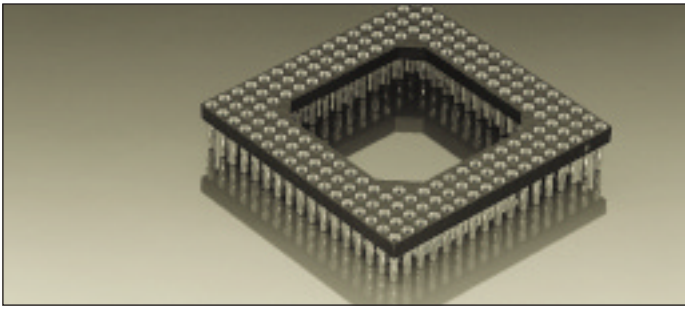



Pin Grid Array sockets with press-fit terminations

PGA sockets are high density connecting devices equipped with machined precision contacts with soft contact clips assuring low insertion/withdrawal forces. Over 200 standard pinouts are available; inquiries for custom varieties are welcome

New compliant press-fit terminations with modified eye of the needle for solderless mount into PCBs with through plated holes guarantee gas-tight contact zones

Insertion characteristics: 6 finger low force

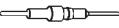
Platings	Sleeve 	Clip 	Pin 
91	5 µm Sn Pb	0.25 µm Au	
93	5 µm Sn Pb	0.75 µm Au	
99	5 µm Sn Pb	5 µm Sn Pb	

Ordering information

Replace **xxx-xx-xxx** with the number of poles, body size and layout numbers as indicated on pages 88 to 92. For example, a 12x12 pin configuration with window and 108 standard soldering contacts as shown on page 88 becomes:
546-93-**108-12-101**-028

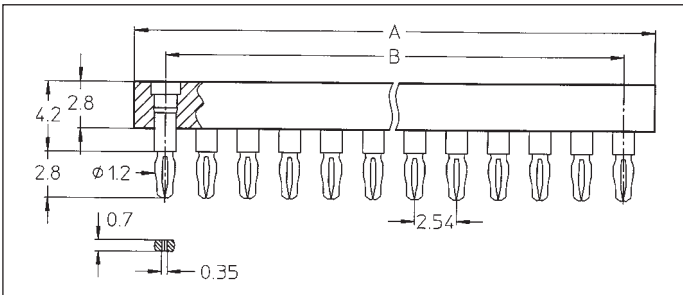

- 546-91-xxx-xx-xxx-036
- 546-93-xxx-xx-xxx-036
- 546-99-xxx-xx-xxx-036

PGA sockets with press-fit terminations for 1.5 to 2.0 mm PCB thickness. Hole diameter 1 (+0.09/-0.06) mm

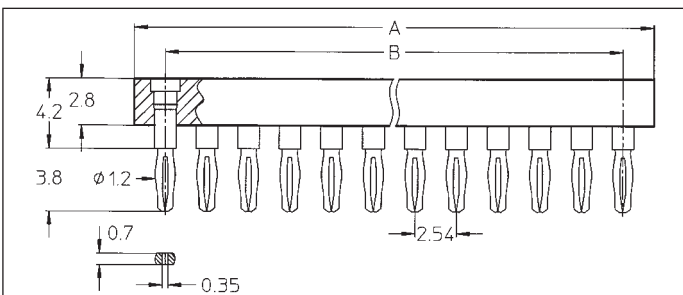

- 546-91-xxx-xx-xxx-035
- 546-93-xxx-xx-xxx-035
- 546-99-xxx-xx-xxx-035

PGA sockets with press-fit terminations for 2.1 to 3.2 mm PCB thickness. Hole diameter 1 (+0.09/-0.06) mm

NEW!

Series 546 PGA sockets with press-fit terminations are now available in all standard **interstitial pinouts**.

For more details consult:

Page 68:

Pages 79 & 83:

Pages 91/92:

product info on press-fit technology
dimensional data
interstitial socket layouts

Series 612 / 614

Pin grid array sockets Carrier types

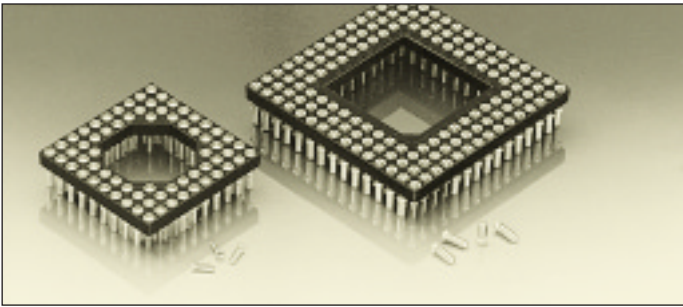



Pin grid array sockets, carrier types

PGA carrier sockets are high density connecting devices having a disposable plastic body equipped with carrier pins. Machined precision contacts with soft contact clips assuring low insertion/withdrawal forces are plugged-on. Over 200 standard pinouts are available; inquiries for custom varieties are welcome

Insertion characteristics: 6 finger low force or 3 finger low force for part number termination 012

Ordering information

Replace **xxx-xx-xxx** with the number of poles, body size and layout numbers as indicated on pages 88 to 92. For example, a 12x12 pin configuration with window and 108 standard soldering contacts as shown on page 88 becomes: 612-93-**108-12-051**-001.

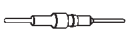
Platings	Sleeve 	Clip 	Pin 
13	0.25 µm Au	0.75 µm Au	
91	5.0 µm Sn Pb	0.25 µm Au	
93	5.0 µm Sn Pb	0.75 µm Au	
97	5.0 µm Sn Pb	Goldflash	
99	5.0 µm Sn Pb	5.0 µm Sn Pb	

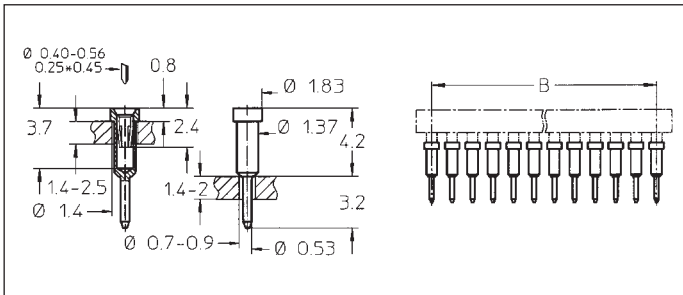

612-13-xxx-xx-xxx-101 **B**

612-91-xxx-xx-xxx-101

612-93-xxx-xx-xxx-101

612-97-xxx-xx-xxx-101

612-99-xxx-xx-xxx-101

PGA carrier sockets with disposable plastic body and carrier pins. Standard contacts are plugged-on

Solder terminations Ø 0.53 mm, length 3.2 mm

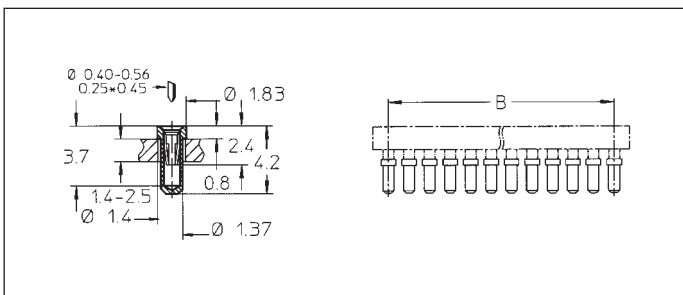

614-13-xxx-xx-xxx-101 **B**

614-91-xxx-xx-xxx-101

614-93-xxx-xx-xxx-101

614-97-xxx-xx-xxx-101

614-99-xxx-xx-xxx-101

PGA carrier sockets with disposable plastic body and carrier pins. Low profile contacts are plugged-on

Solder terminations Ø 1.37 mm, total length of contact 4.2 mm

Requires Ø 1.4 mm holes in PCB

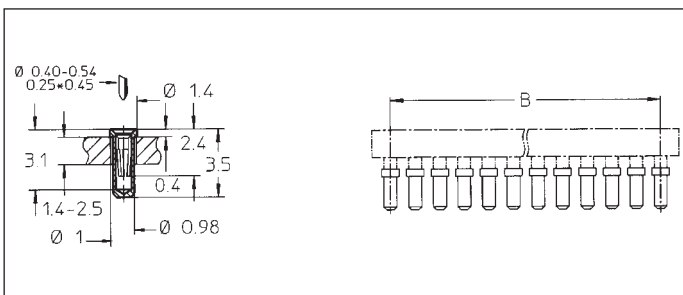

614-13-xxx-xx-xxx-112 **B**

614-91-xxx-xx-xxx-112

614-93-xxx-xx-xxx-112

614-97-xxx-xx-xxx-112

614-99-xxx-xx-xxx-112

PGA carrier sockets with disposable plastic body and carrier pins. Low profile ultra thin contacts are plugged-on

Solder terminations Ø 0.98 mm, total length of contact 3.5 mm

Requires Ø 1 mm holes in PCB

10	01	Solder	80
11	01	Solder	80
12	01	Carrier	84
14	01	Carrier	84
14	12	Carrier	84
15	01	Solder	80
15	03	Solder	80
16	..	Interconnect	81
17	11	Interstitial	82
2x	.1	Wire-wrap	81
46	..	Press-Fit	83
5.	..	Interconnect	81

XX XX page:



5 Standard PGA
6 Carrier PGA

Insertion characteristics:
- standard
B very low
C ultra low

size of window:
see pages 88 to 92
for most popular
footprints.

	plating: sleeve (pin)	clips
10	0.25 µm Au	-
13	0.25 µm Au	0.75 µm Au
90	5 µm Sn	-
91	5 µm Sn	0.25 µm Au
93	5 µm Sn	0.75 µm Au
97	5 µm Sn	Goldflash
99	5 µm Sn	5 µm Sn

total number of pins

Size of body:									
Polyester	05	06	07	08	09	10	11	12	13
	5x5	6x6	7x7	8x8	9x9	10x10	11x11	12x12	13x13
Epoxy	14	15	16	17	18	19	20	21	
	14x14	15x15	16x16	17x17	18x18	19x19	20x20	21x21	
Polyester and stand offs	35	36	37	38	39	40	41	42	43
	5x5	6x6	7x7	8x8	9x9	10x10	11x11	12x12	13x13
Polyester and self clinching snap-in pins	44	45	46	47	48	49	50	51	
	14x14	15x15	16x16	17x17	18x18	19x19	20x20	21x21	
	55	56	57	58	59	60	61	62	63
	5x5	6x6	7x7	8x8	9x9	10x10	11x11	12x12	13x13
	64	65	66	67	68	69	70	71	
	14x14	15x15	16x16	17x17	18x18	19x19	20x20	21x21	
	75	76	77	78	79	80	81	82	83
	5x5	6x6	7x7	8x8	9x9	10x10	11x11	12x12	13x13
	84	85	86	87	88	89	90	91	
	14x14	15x15	16x16	17x17	18x18	19x19	20x20	21x21	

If the desired footprint does not exist in this catalogue, please photocopy this page, complete it and send it to your PRECI-DIP agent.

Your address ►

Ordering information

1 Type of PGA

2 Type of pin

See opposite page

3 Plating

 Sleeve

 Contact (clips)

4 Size of body

 ×

5 Semiconductor device used

6 Quantity

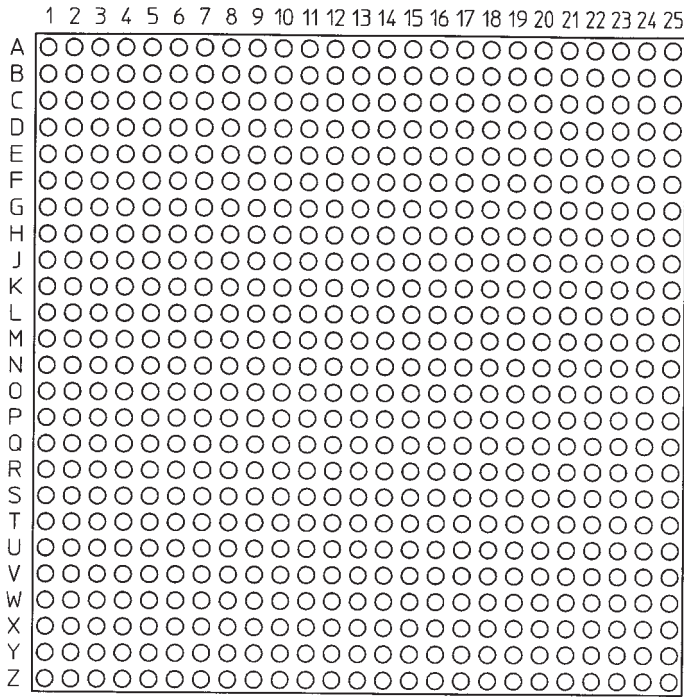

Top view

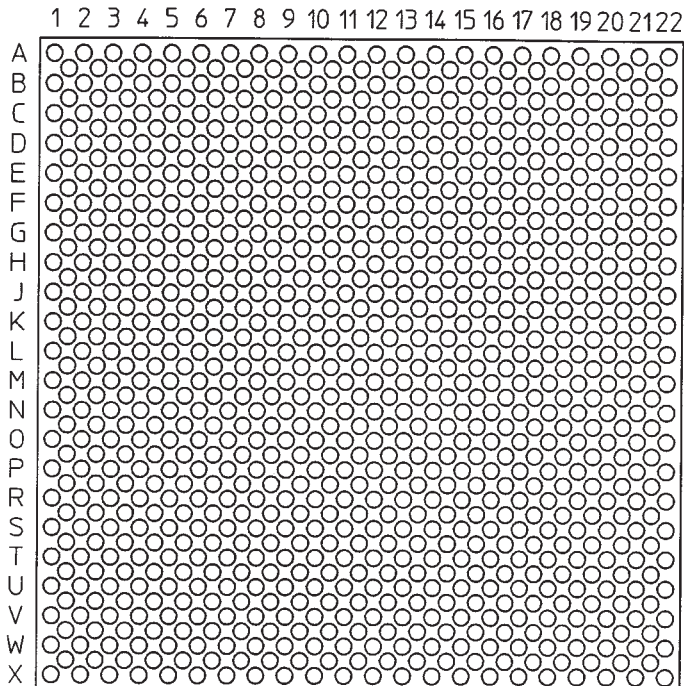

Example:

Fill in the position of pins

Mark of the window

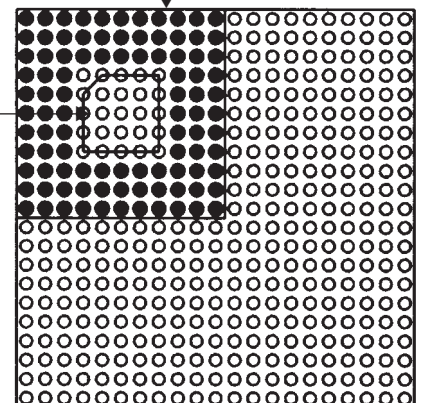

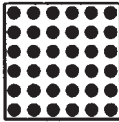
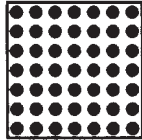
					TOP VIEW
5x5 xxx-xx-022-05-001		6x6 xxx-xx-036-06-000		7x7 xxx-xx-049-07-000	

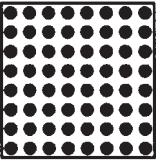
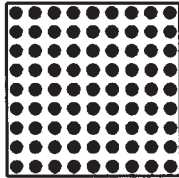
					
8x8 xxx-xx-064-08-000		9x9 xxx-xx-081-09-000			

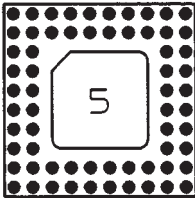
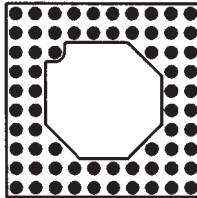
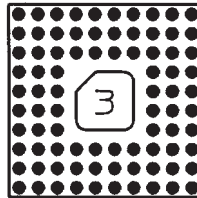
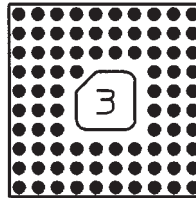
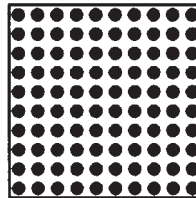
					
10x10 xxx-xx-037-10-061	10x10 xxx-xx-064-10-051	10x10 xxx-xx-068-10-061	10x10 xxx-xx-084-10-031	10x10 xxx-xx-085-10-031	10x10 xxx-xx-100-10-000

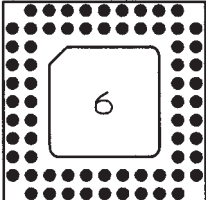
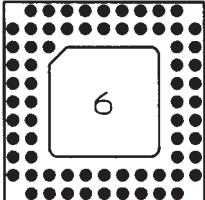
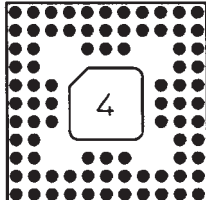
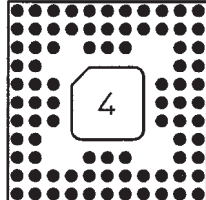
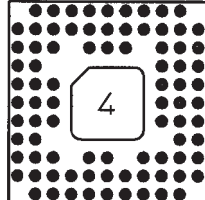
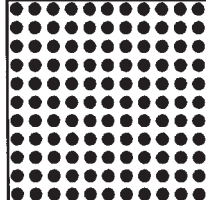
					
11x11 xxx-xx-068-11-061	11x11 xxx-xx-069-11-061	11x11 xxx-xx-084-11-042	11x11 xxx-xx-085-11-041	11x11 xxx-xx-085-11-045	11x11 xxx-xx-121-11-000

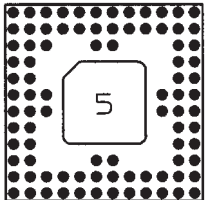
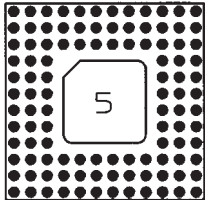
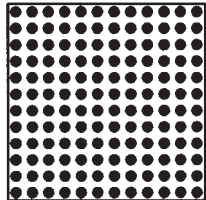
					
12x12 xxx-xx-089-12-051	12x12 xxx-xx-108-12-051	12x12 xxx-xx-144-12-000			

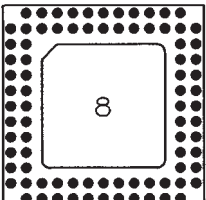
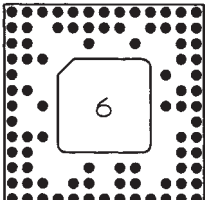
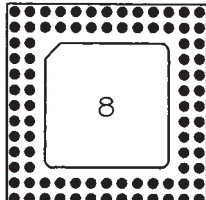
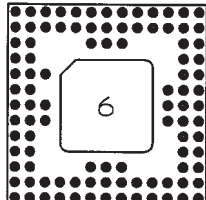
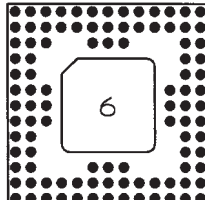
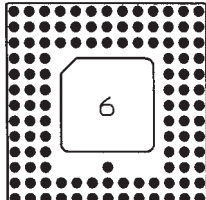
					
13x13 xxx-xx-084-13-081	13x13 xxx-xx-088-13-062	13x13 xxx-xx-088-13-081	13x13 xxx-xx-100-13-063	13x13 xxx-xx-101-13-061	13x13 xxx-xx-114-13-061

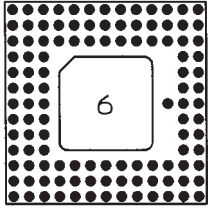
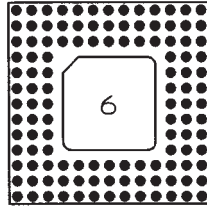
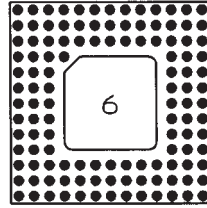
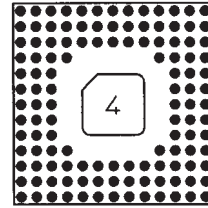
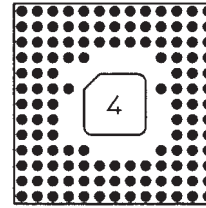
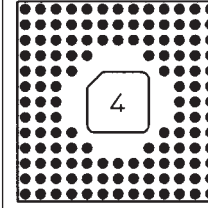
					
13x13	13x13	13x13	13x13	13x13	13x13
xxx-xx-114-13-062	xxx-xx-120-13-061	xxx-xx-121-13-061	xxx-xx-124-13-041	xxx-xx-128-13-041	xxx-xx-132-13-041

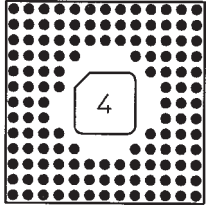
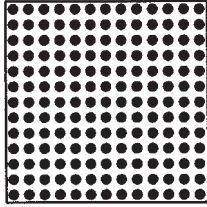
					
13x13	13x13				TOP VIEW
xxx-xx-133-13-041	xxx-xx-169-13-000				

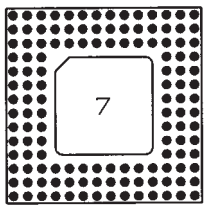
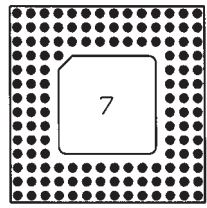
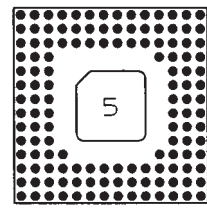
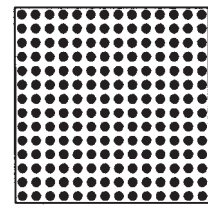
					
14x14	14x14	14x14	14x14		
xxx-xx-132-14-071	xxx-xx-133-14-071	xxx-xx-135-14-051	xxx-xx-196-14-000		

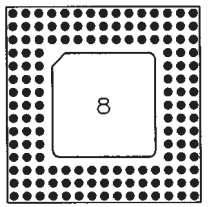
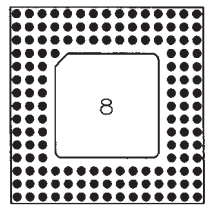
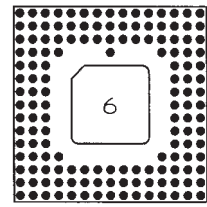
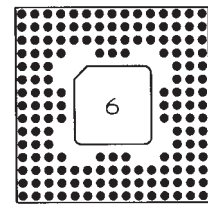
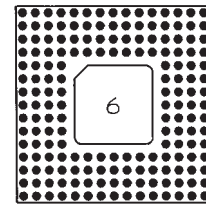
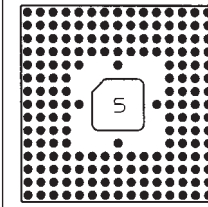
					
15x15	15x15	15x15	15x15	15x15	15x15
xxx-xx-144-15-081	xxx-xx-145-15-081	xxx-xx-149-15-063	xxx-xx-160-15-061	xxx-xx-176-15-061	xxx-xx-181-15-051

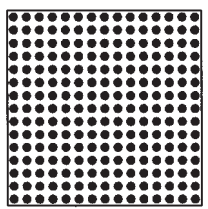
					
15x15					
xxx-xx-225-15-000					

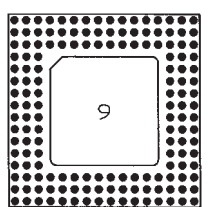
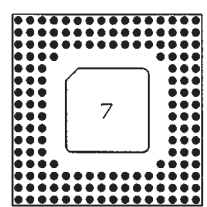
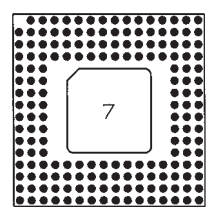
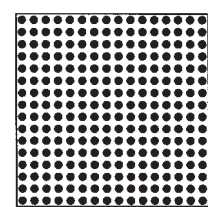
					
16x16	16x16	16x16	16x16		
xxx-xx-156-16-091	xxx-xx-160-16-071	xxx-xx-175-16-072	xxx-xx-256-16-000		

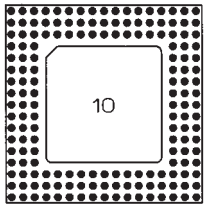
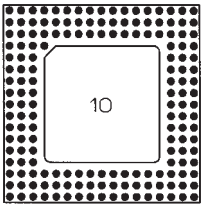
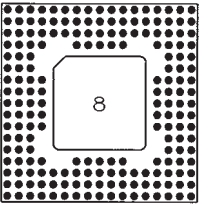
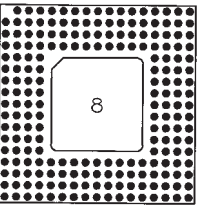
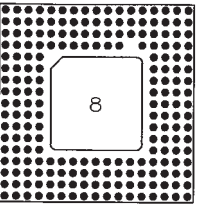
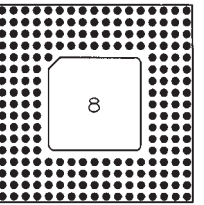
					
17x17	17x17	17x17	17x17	17x17	17x17
xxx-xx-168-17-101	xxx-xx-169-17-101	xxx-xx-192-17-081	xxx-xx-207-17-081	xxx-xx-207-17-082	xxx-xx-209-17-081

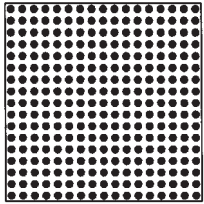
					TOP VIEW
17x17					
xxx-xx-289-17-000					

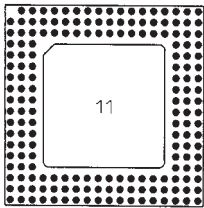
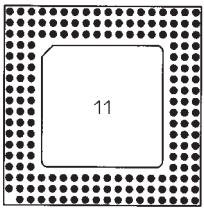
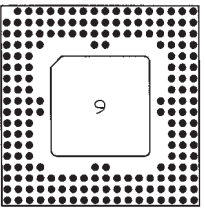
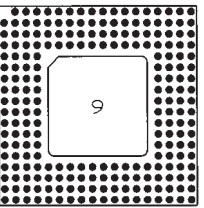
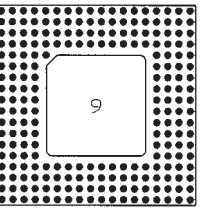
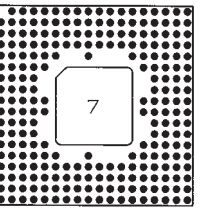
					
18x18	18x18	18x18	18x18	18x18	18x18
xxx-xx-179-18-111	xxx-xx-179-18-112	xxx-xx-191-18-091	xxx-xx-223-18-091	xxx-xx-225-18-091	xxx-xx-241-18-071

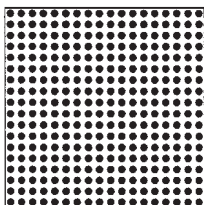
					
18x18					
xxx-xx-324-18-000					

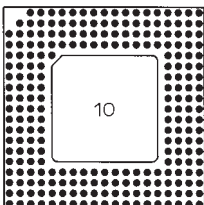
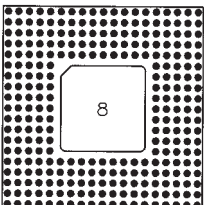
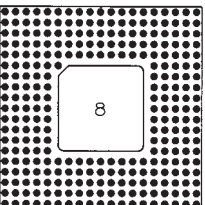
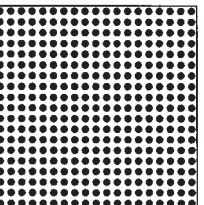
					
19x19	19x19	19x19	19x19		
xxx-xx-238-19-101	xxx-xx-280-19-081	xxx-xx-281-19-081	xxx-xx-361-19-000		

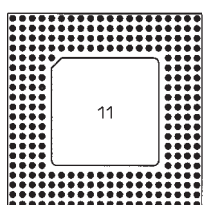
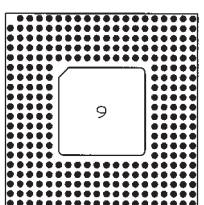
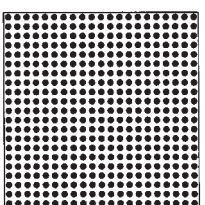
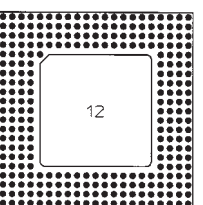
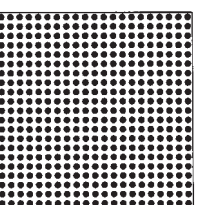
					
20x20	20x20	20x20		21x21	21x21
xxx-xx-257-20-111	xxx-xx-299-20-091	xxx-xx-400-20-000		xxx-xx-273-21-121	xxx-xx-441-21-000

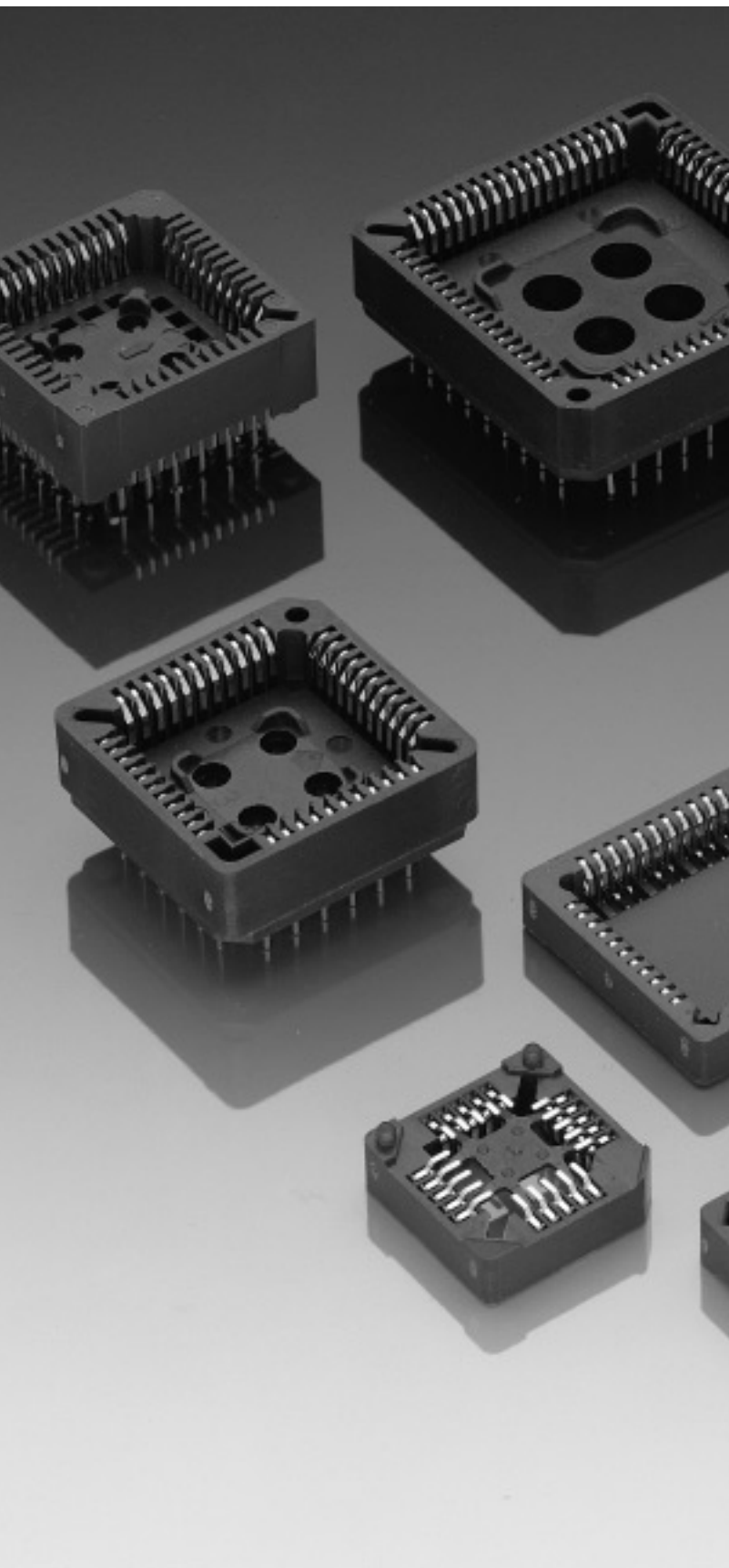

Technical specifications

	Series 540	504
--	---------------	-----

Materials

- Insulator: Glass filled thermoplastic, self extinguishing UL 94 V-0,
- Contact: Plated Copper alloy overall nickel underplating, finish:

	tin/lead	tin/lead
active contact area	tin/lead	tin/lead
termination area	tin/lead	tin/lead

Mechanical data

- Contact pressure (per contact) (N min.):

1.5	1.2
-----	-----
- Mechanical life (cycles):

50	25
----	----

Electrical data

- Rated current (A):

	1	-
SMD types	1	-
Thru-hole types	2	1
- Contact resistance: 20 mΩ max.
- Insulation resistance: 5000 MΩ min.
- Dielectric strength: 600 V_{RMS} min.
- Capacitance: 2 pF max.

Environmental data

- Operating temperature: -55/+125 °C
- Vibration (10–2000 Hz, 15 g): no electrical discontinuity > 1 μs
- Climatic category (IEC): 55/85/21

PRECI-DIP

DURTAL

Series 540

Sockets for Plastic Leaded Chip Carriers (PLCC)
Solder tail

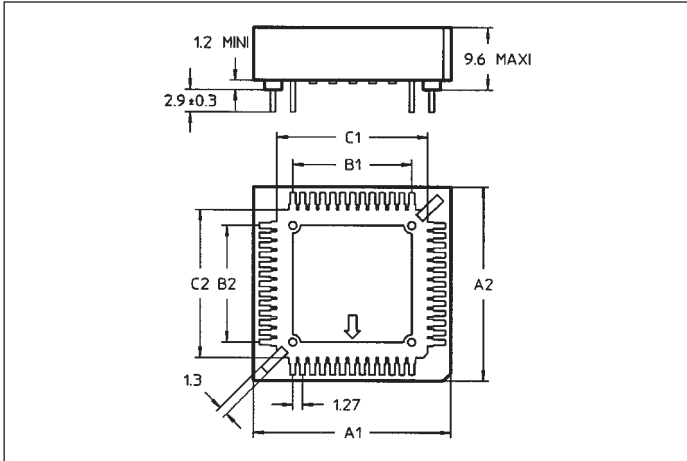

Series 540 PLCC sockets are designed to accept JEDEC type leaded plastic substrates

The insulator body has polarizing features for both substrate and PCB insertion

Contacts of highly reliable design guarantee safe component retention thanks to positive spring action

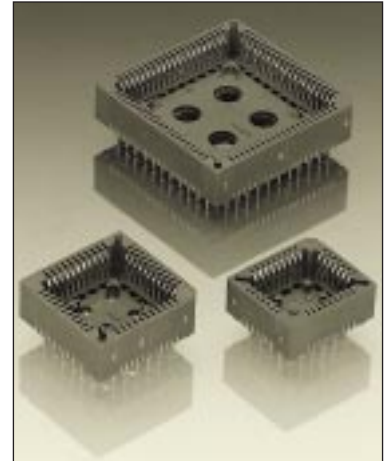

Plating	Stamped contacts
99	tin-lead over nickel Please note: 99 is only plating available for this product.

Ordering information
For standard part numbers, please refer to table "Order Codes"
For PCB hole patterns see below

No. of poles	Order Codes	Dimensions					
		A ₁	A ₂	B ₁	B ₂	C ₁	C ₂
20	540-99-020-24-000-1	14.98	14.98	5.08	5.08	9.14	9.14
28	540-99-028-24-000-1	17.52	17.52	7.62	7.62	11.68	11.68
32*	540-99-032-24-000-1	17.52	20.06	7.62	10.16	11.78	14.32
44	540-99-044-24-000-1	22.60	22.60	12.70	12.70	16.76	16.76
52	540-99-052-24-000-1	25.15	25.15	15.24	15.24	19.30	19.30
68	540-99-068-24-000-1	30.22	30.22	20.32	20.32	24.38	24.38
84	540-99-084-24-000-1	35.31	35.31	25.40	25.40	29.46	29.46

* rectangular

PCB hole patterns thru-hole types Series 540 / 504

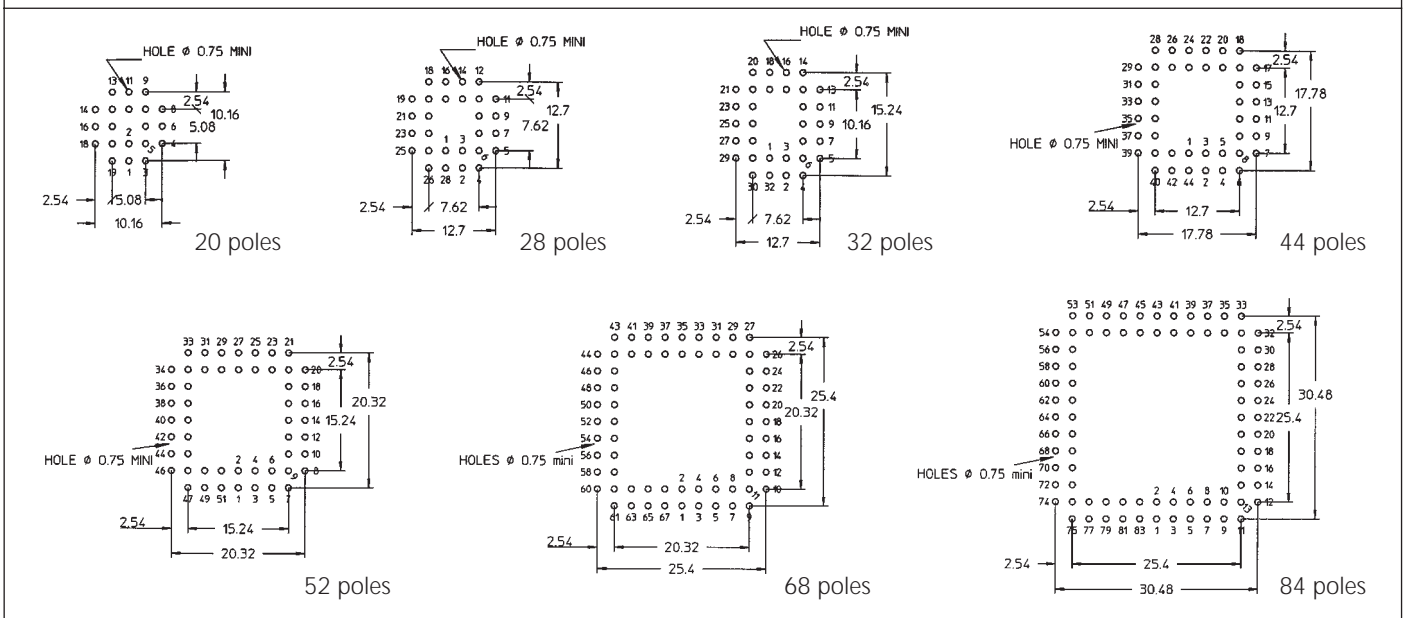

Series 540

Sockets for Plastic Leaded Chip Carriers (PLCC)

SMT terminations

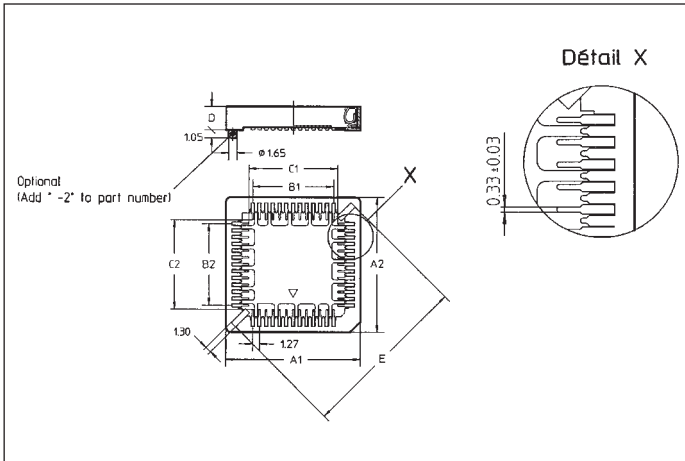

Series 540 PLCC sockets with SMT terminations come with square sizes for IC-packages according to JEDEC MO-047, rectangular size (32) according to JEDEC MO-052 = low profile

Solder tail width 0.33 mm

Guaranteed coplanarity tolerance of SMT terminations max. 0.10 mm

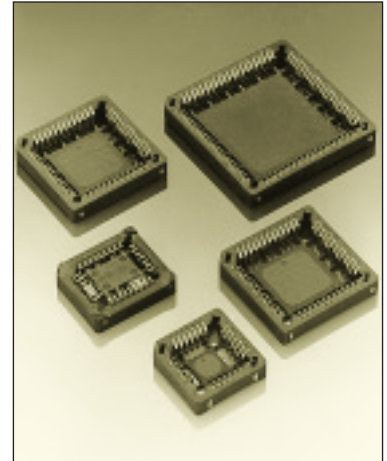

Plating	Stamped contacts
99	tin-lead over nickel Please note: 99 is only plating available for this product.

Ordering information
Please refer to table Order Codes
Standard packaging: tube

Packaging options:
Tape on reel (add suffix TR, ex 540-99-020-17-400-TR)
For PCB layout see below

No. of poles	Order Codes		Dimensions							
	Standard parts:	Parts with 2 positioning pegs:	A ₁	A ₂	B ₁	B ₂	C ₁	C ₂	D	E
20	540-99-020-17-400	540-99-020-17-400-2	14.86	14.86	5.08	5.08	7.26	7.26	4.60	16.00
28	540-99-028-17-400	540-99-028-17-400-2	17.40	17.40	7.62	7.62	9.80	9.80	4.60	19.70
32*	540-99-032-17-400	540-99-032-17-400-2	16.90	19.45	7.62	10.16	9.61	12.16	3.90	22.00
44	540-99-044-17-400	540-99-044-17-400-2	22.48	22.48	12.70	12.70	14.88	14.88	4.60	27.00
52	540-99-052-17-400	540-99-052-17-400-2	25.40	25.40	15.24	15.24	17.50	17.50	4.60	30.80
68	540-99-068-17-400	540-99-068-17-400-2	30.54	30.54	20.32	20.32	22.50	22.50	4.60	37.65
84	540-99-084-17-400	540-99-084-17-400-2	35.56	35.56	25.40	25.40	27.62	27.62	4.60	45.10

* rectangular

PCB layout SMD types Series 540...

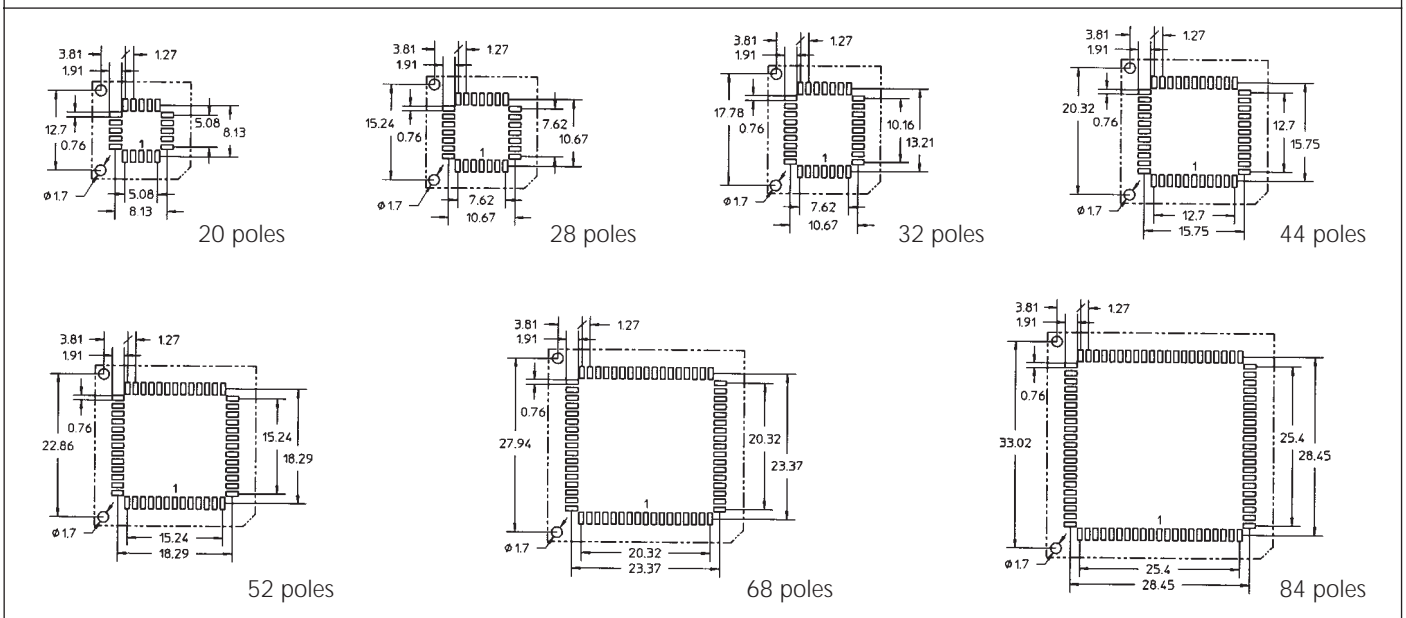

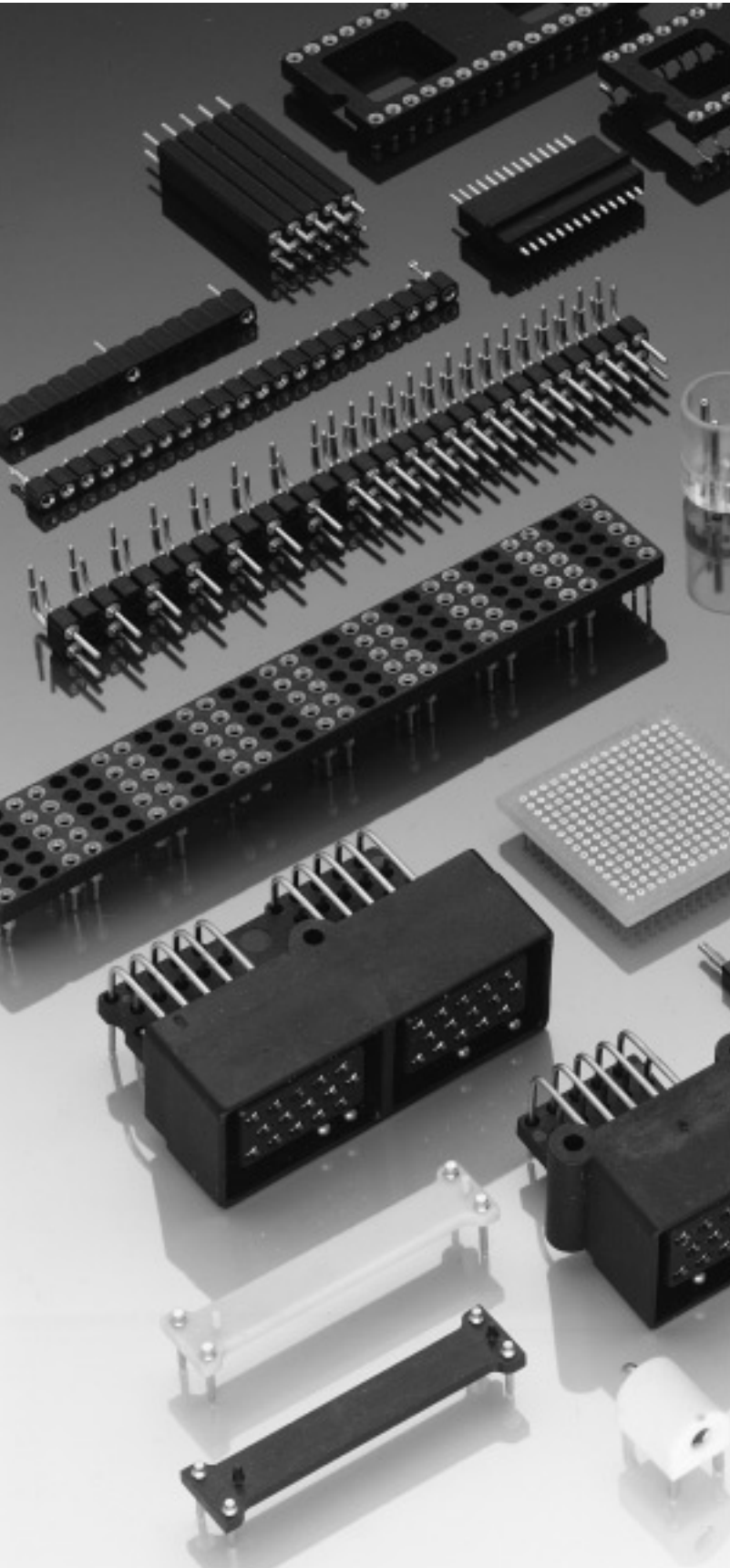

Know-how and flexibility

Manufacturing customized product requires above average knowledge and experience. Excellent design capabilities are necessary and a powerful production unit, capable of fulfilling high quality standards. Professionals with an open mind to new design ideas and the ability to turn these ideas into reality quickly at reasonable cost – that is the Preci-Dip crew.

In-house production

Preci-Dip's in-house production capability is practically total, from the raw material to the finished part. It includes precision machining, clip stamping and electroplating of the contact as well as injection molding of the insulator body and automatic assembly.

High quality level

Total control over all important steps of production and a fully integrated Q.A. system allow to guarantee a constantly high quality level. Raw products coming from external sources undergo stringent inspections before they are accepted at Preci-Dip's manufacturing.

Reliability

One of our main goals is reliability. Reliability of the product. Reliability in serving our customers. Reliability in assuring fair prices and delivery times. You may find out for yourself the day you try us.

PRECIP-DIP – people who care

PRECIP-DIP

DURTAL

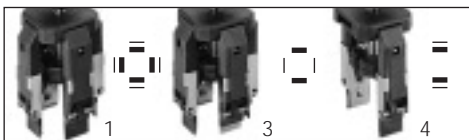
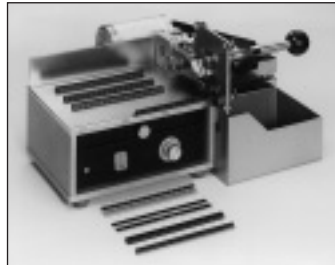

Tools

Cutter / strip saw / PLCC extractor / PGA inserter and extractor

Professional header cutter

Cutting of straight and right angle pin headers and strips

Adjustable plate locator accepts 2.54–10 mm headers.
Blade height adjustable with adjustment screw, replacement blades, blade straight action of 12 mm.
Application range: Cutting of straight and right angle headers without contact loss. Capability to cut one, two and three row headers with 1.0–10 mm height.

Order No. 0200-0108

Strip saw

Please consult

Universal PLCC Extractor Tool

All parts are electrically conductive in order to avoid damage due to electrostatic discharges.

Order No. 9946

Insertion tool for PGA devices from 13×13 to 24×24.

Easy to use, safe and accurate

This tool does not require any prior adjustment and the device can be easily inserted into the socket without damage. The fine adjustment to the size of the socket and insertion are done in one simple operation. In order to avoid electrostatic damage, all materials used are electrically conductive.

Two pressing dies are supplied with the tool.

Type 1 suitable for PGAs 13×13 to 24×24

Type 2 suitable for PGAs 17×17 to 24×24

Operation of tool

Place PGA device correctly aligned on socket. By turning the knob towards the "closed" marker, the claws will grip under the socket and the pressing die will gently insert the device into the socket. To remove tool turn the knob towards the "open" mark, the claws expand and the tool can be removed from the socket.

Order No. 8980200

Extraction tool for PGA devices from 10×10 to 24×24.

Easy to use, safe and accurate

This tool does not require prior adjustment and the PGA device can be extracted easily from its socket without damage. The fine adjustment to the size of the device and the extraction are done in one simple operation. In order to avoid electrostatic damage all material used are electrically conductive.

During the extraction process, the jaws of the tool grip the device firmly. There is no danger of slipping off and damaging the component.

Minimum space requirements between two adjacent components is 2 to 4 mm (.78" to 1.57").

Operation of tool

By turning the knob towards the "closed" marker, the claws grip under the device and extract it from the socket without damage. To remove the device from tool, the claws are expanded by turning the knob towards the "open" mark: the device can now be removed.

Order No. 8980101 tool 1: 4 jaws, 4 rests

8980103 tool 3: 2 jaws, 2 rests

8980104 tool 4: 2 jaws, 2 rests

Reference	page
110...01-505	70
110...10-00	70
110...41-001	53
110...41-005	55
110...41-105	59
110...41-105161	60
110...41-605	56
110...41-801	67
111...41-001	54
114...41-117	59
114...41-1..161	60
115...41-00.	57
116...41-0..	58
117...41-005	61
121...41-001	62
122...41-001	62
123...41-001	62
124...41-002	62
126...41-00.	71
146...41-0..	64
150...00-001	72
150...00-106	59
150...00-106161	60
151...00-0..	72
153...00-001	73
160...00-001	73
163...00-001	73
170...00-001	73
173...00-001	73
180...00-001	73
183...00-001	73
210...41-001	63
217...41-005	61
299...10-00.	75
299...11-001	75
310...01-640	36
310...01-666	36
310...41-001	36
310...41-105	40
310...41-205	40
311...41-001	37
315...41-001	37
315...41-003	37
316...41-0..	38
317...01-687	17
317...41-005	17
321...41-001	42
322...41-001	42
323...41-001	42
324...41-002	42
326...41-00.	42
346...41-0..	41

Reference	page
350...00-001	44
350...00-006	43
350...00-012	17
350...00-106	46
350...00-206	46
350...01-666	43
351...00-0	44
353...00-001	74
360...00-001	74
363...00-001	74
370...00-001	74
373...00-001	74
380...00-001	74
383...00-001	74
399...10-003	39
399...10-009	45
410...10-00.	70
410...41-001	36
410...41-105	40
411...41-001	37
415...41-001	37
416...41-0..	38
421...41-001	42
422...41-001	42
423...41-001	42
424...41-002	42
426...41-00.	42
446...41-0..	41
450...00-001	44
450...00-006	43
450...00-106	46
451...00-0..	44
453...00-001	74
460...00-001	74
463...00-001	74
470...00-001	74
473...00-001	74
480...00-001	74
483...00-001	74
499...10-003	39
499...10-009	45
504...24-000	95
507...	85
510...	80
511...	80
515...	80
516...	81
517...	82
521...	81
522...	81
523...	81
540...17-400	96
540...24-000	94

Reference	page
546...	83
550...	81
551...	81
612...PGA	84
612...41-001	65
614...PGA	84
614...144 PGA	82
614...31-012	66
614...41-001	66
712...41-001	47
714...31-0..	48
714...41-0..	47
800...10-001	30
800...10-002	30
800...20-001	31
800...30-001	32
800...40-001	32
800...65-001	33
800...66-001	33
801...10-001	22
801...10-002	23
801...10-003	24
801...10-004	29
801...10-005	24
801...10-012	23
801...20-001	25
801...20-002	25
801...30-001	26
801...30-002	26
801...40-001	27
801...40-002	27
801...53-001	29
801...65-001	28
801...66-001	28
802...10-001	30
802...10-002	30
802...20-001	31
802...30-001	32
802...65-001	33
802...66-001	33
803...10-001	22
803...10-002	23
803...10-003	24
803...10-004	29
803...10-005	24
803...10-012	23
803...10-227	27
803...20-001	25
803...30-001	26
803...30-002	26
803...53-001	29
803...65-001	28
803...66-001	28
805...10-001	22
805...10-012	23
830...10-001	19
830...20-001	19
830...30-001	20

Reference	page
831...10-001	18
831...20-001	18
831...30-001	20
831...64-001	21
832...10-001	19
832...20-001	19
832...30-001	20
833...10-001	18
833...20-001	18
833...30-001	20
833...64-001	21
850...10-001	13
850...20-001	14
850...30-001	15
850...40-001	15
851...10-001	10
851...20-001	11
851...30-001	12
851...40-001	12
852...10-001	13
852...10-002	13
852...20-001	14
852...20-002	14
852...30-001	15
853...10-001	10
853...10-002	10
853...20-001	11
853...20-002	11
853...30-001	12
854...10-001	13
854...20-001	14
854...30-001	15
855...10-001	10
855...20-001	11
855...30-001	12
890...10-...	34
890...20-...	35
892...10-...	34
892...20-...	35
917...41-005	76
999...	77
Tools	98

New products for:

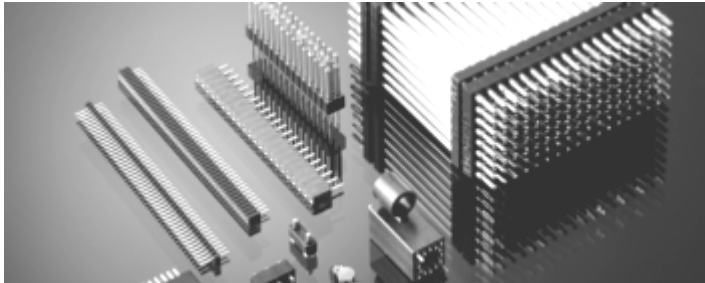

- Telecommunications

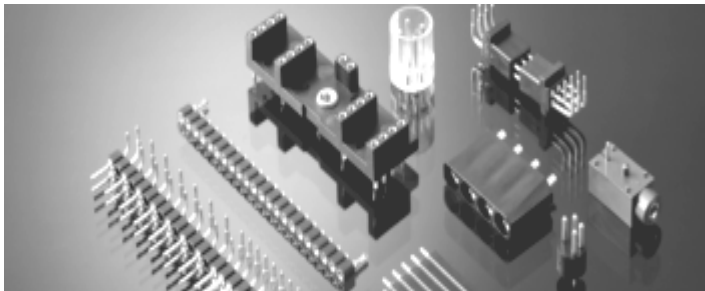

- Industrial electronics

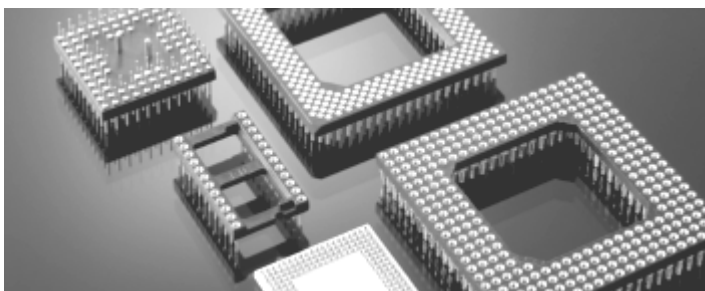

- Computer industry

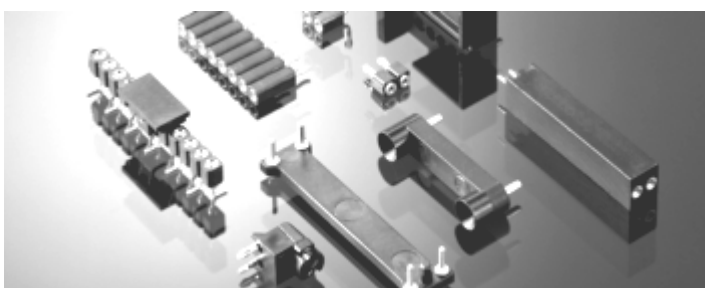

- Automotive industry

Product Description	File Nbr	Page
PCB Connectors		
1 mm PCB Socket Connector Series 861	IP9901.01	101
1 mm PCB Pin Connector Series 860	IP9901.04	103
PCB Connector 1.27 mm SMD, automatic assembly Series 850, 851	IP0001.04	105
PCB Socket Connector 2 mm SMD, automatic assembly Series 831	IP0001.03	107
2 mm polarised PCB Socket Connector Series 831 / 833	IP0003.01	109
2 mm shrouded PCB Pin Connector Series 830 / 832	IP0003.02	113
PCB Socket Connector 2.54 mm SMD, automatic assembly Series 310, 410	IP0001.01	117
PCB Socket Connector 2.54 mm SMD, automatic assembly Series 801, 803	IP0001.02	119
PCB Pin Connector 2.54 mm SMD, automatic assembly Series 350	IP0003.04	121
Shrouded Pin Connector 2.54 mm, machined contacts Series 800 to 804	IP0000.01	123
DIL Sockets		
DIL Socket SMD, automatic assembly Series 110 / 114	IP0001.05	127
PGA, BGA Sockets		
Interstitial PGA Socket SMD Series 514	IP9901.02	130
Interstitial PGA Socket solderless Press-Fit Series 546	IP9901.03	132
BGA Adapter Socket SMD Series 514 / 550	IP9901.05	134
Spring loaded Contacts and Connectors		
Springloaded Contact low profile	IP0002.01	136
Springloaded Contact ultra thin	IP0002.02	138
Modular low profile Springloaded Connector Series 811 and 813	IP0000.02	140
Springloaded Chip Card Connector	IP0000.03	142
Spring Manufacturing		144

1 mm Socket Connector with precision machined Contacts Series 861

1. Description and general features

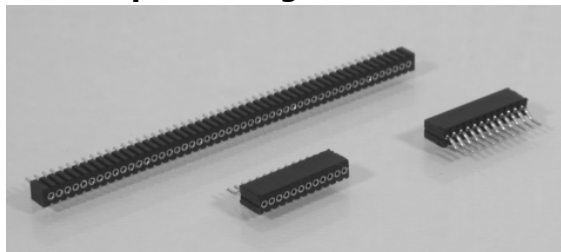

1.1 General description

Series 860 connectors, introduced exclusively by Preci-Dip to its metric product line, are equipped with machined contacts in a pitch of 1 mm.

They come in a single row version with 50 poles maximum and have a very low profile insulator withstanding reflow soldering temperatures. The connector is suitable for through hole or SMD soldering to the PCB.

The female contacts have a screw-machined outer contact sleeve equipped with an inserted four finger contact clip. This clip is a new design and was optimised by FEM "Finite Elements Modelling".

1.2 Advantages

Metric 1 mm pitch saves approximately 30% of

space per surface unit when compared with 1.27mm pitch.

Very low profile insulator allows interconnection of PCBs with a stacking distance of only 4 mm when used with trough-hole soldering tails.

Thanks to the new clip design, male contacts with 0.4 mm diameter can be used and guarantee mechanical strength, combined with low insertion/extraction forces (specially important with high pin counts).

1.3 Applications

Specially recommended for applications with extremely little space in surface and/or height, and high requirements in electrical quality and mechanical strength, such as:

- Industrial sensors, remote control transceivers
- Medical equipment, systems with embedded microprocessors
- Portable terminals, mobile phones, professional mobile radios

1.4 Optional versions

Currently none

2. Technical Specifications

2.1 Environmental

Operating temperature	-55 ... + 125°C
Climatic Category (IEC)	55 / 125 / 21
Solderability	235°C, 5s
Resistance to soldering heat	280°C, 10s

2.2 Materials

Contact body	Machined brass, tin plating 5 µm SnPb over 2.5 µm Ni
Contact spring	BeCu, gold plated (0.25 or 0.75 µm) over Ni
Insulator	Glass fibre reinforced liquid crystal polymer LCP, self-extinguishing UL94V-0, colour black

2.3 Mechanical Characteristics

Accepts pins	Diameter 0.40 to 0.46 mm
Solder tail	Cylindrical, diameter 0.40 mm
Mechanical life	min.500 cycles
Coplanarity SMD terminations	0.1 mm

2.4 Electrical Characteristics

Operating voltage	50 V _{RMS} / 60 V _{DC}
Continuous operating current	max. 1 A per terminal
Contact resistance	max 10 mΩ
Insulation resistance	10'000 MΩ (after climatic tests)
Dielectric strength	500 V _{RMS}
Air and creepage distances	0.20 mm
Capacitance	1 pF max.

3. Ordering Information

3.1 Dimensions, Order Code Numbers and Packaging Information

Contact Plating Code -PP-: **-91-** **Body: tin, Clip: gold 0.25 um**
 -93- **Body: tin, Clip: gold 0.75 um**

Code for number of contacts –ONN-: (example for a 26 poles connector: -026-)

Packaging: version with straight solder pins: in box
 SMD versions: Tape & Reel packaging

3.1.1 Socket Connector, single row, straight solder pin, PN 861-PP-ONN-10-001101

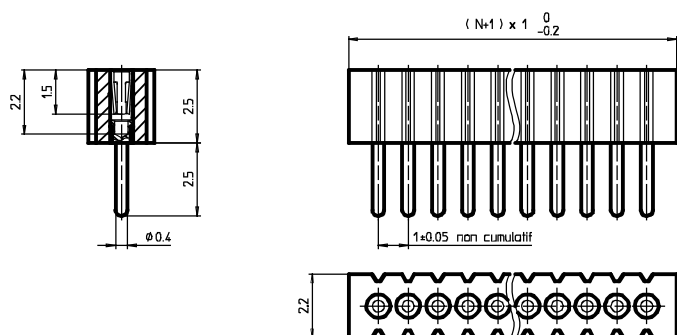

Available number of pins: 2 to 50

3.1.2 Socket Connector, single row, SMD horizontal mount, PN 861-PP-ONN-40-001191

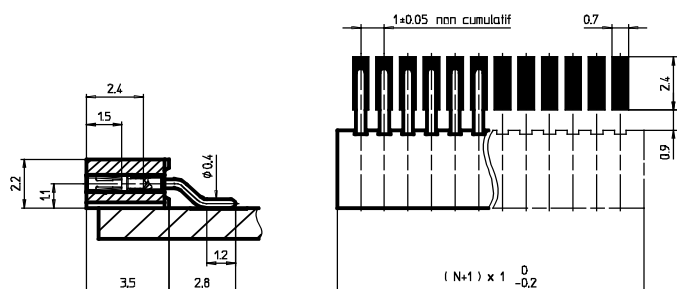

Available number of pins: 6 to 12

Packaging:	6 to 8 poles	10 to 12 poles
Tape width	16 mm	24 mm
Pitch on tape	12 mm	12 mm
Reel diameter	330 mm	330 mm
Number of pcs per reel:	2000	2000
Number of pcs per box:	10'000	6000

3.2 Availability

Now

1 mm Pin Connector with Precision machined Contacts Series 860

1. Description and general features

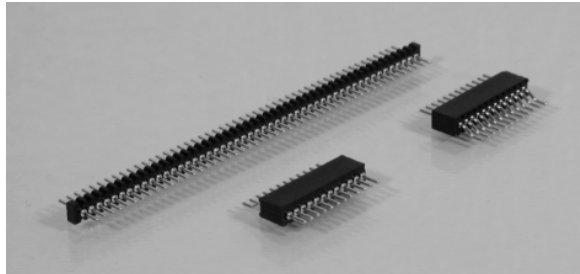

1.1 General description

Series 860 connectors, introduced exclusively by Preci-Dip to its metric product line, are equipped with machined contacts in a pitch of 1 mm.

They come in a single row version with 50 poles maximum and have a very low profile insulator withstanding reflow soldering temperatures. The connector is suitable for through hole or SMD soldering to the PCB

1.2 Advantages

Metric 1 mm pitch saves approximately 30% of space per surface unit when compared with 1.27mm pitch.

Very low profile insulator allows interconnection of PCBs with a stacking distance of only 4 mm when used with trough-hole soldering tails.

1.3 Applications

Specially recommended for applications with extremely little space in surface and/or height, and high requirements in electrical quality and mechanical strength, such as:

- Industrial sensors, remote control transceivers
- Medical equipment, systems with embedded microprocessors
- Portable terminals, mobile phones, professional mobile radios

1.4 Optional versions

Currently none

2. Technical Specifications

2.1 Environmental

Operating temperature	-55 ... + 125°C
Climatic Category (IEC)	55 / 125 / 21
Solderability	235°C, 5s
Resistance to soldering heat	280°C, 10s

2.2 Materials

Contact	Machined brass, gold plated 0.25 μm Au or tin plated 5 μm SnPb over 2.5 μm Ni
Insulator	Glass fibre reinforced liquid crystal polymere LCP, self-extinguishing UL94V-0, colour black

2.3 Mechanical Characteristics

Contact pin	Cylindrical, diameter 0.40 mm
Solder tail	Cylindrical, diameter 0.40 mm
Mechanical life	min.500 cycles
Coplanarity SMD terminations	0.1 mm

2.4 Electrical Characteristics

Operating voltage	50 V _{RMS} / 60 V _{DC}
Continuous operating current	max. 1 A per terminal
Insulation resistance	10'000 M Ω (after climatic tests)
Dielectric strength	500 V _{RMS}
Air and creepage distances	min. 0.20 mm
Capacitance	max. 1 pF

3. Ordering Information

3.1 Dimensions, Order Code Numbers and Packaging Information

Contact Plating Code -PP-: -10- Gold 0.25 um
 -90- Tin

Code for number of contacts –ONN-: (example for a 26 poles connector: -026-)

Packaging: version with straight solder pins: in box
 SMD versions: Tape & Reel packaging

3.1.1 Pin Connector, single row, straight solder pin, PN 860-PP-0NN-10-001101

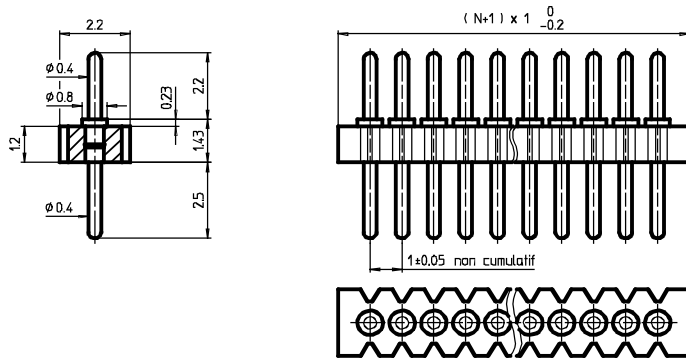

Available number of pins: 2 to 50

3.1.2 Pin Connector, single row, SMD horizontal mount, PN 860-PP-0NN-40-001191

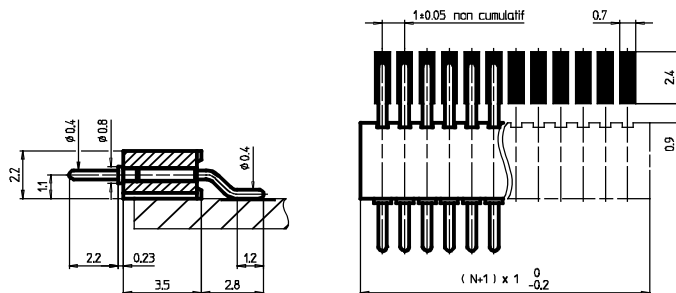

Available number of pins: 6 to 12

Packaging:	6 to 8 poles	10 to 12 poles
Tape width	16 mm	24 mm
Pitch on tape	12 mm	12 mm
Reel diameter	330 mm	330 mm
Number of pcs per reel:	2000	2000
Number of pcs per box:	10'000	6000

3.2 Availability

Now

PCB Connector Strip 1.27 mm SMD for automatic assembly Series 850/851

1. Description and general feature

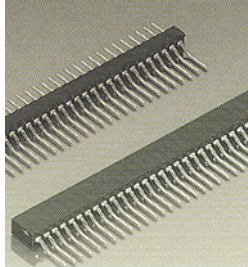

1.1 General description

The 1.27 mm connectors for SMD mount Series 850-...- 40.251191 (pin) and Series 851-...-40-252191 (receptacle) are now available from PRECI-DIP with Tape & Reel packaging acc. to EIA 481 Standard and with modified plastic body for automatic assembly on the PCB.

They come in single row version with min. 6 and max. 12 poles.

The max. number of poles is given by the coplanarity limitations and the tape width of the existing tapes.

1.2 Advantages

The modified plastic body with enlarged width makes automatic assembly with standard vacuum nozzle possible.

1.3 Applications

Specially recommended for high volume applications on automatic PCB assembly lines.

1.4 Optional versions

Same connector strips also available without Tape & Reel packaging and plastic cap, please see PRECI-DIP catalogue 10.

2. Technical Specifications

2.1 Environmental

Operating temperature	-55 ... + 125°C
Climatic Category (IEC)	55 / 125 / 21
Solderability	235°C, 5s
Resistance to soldering heat	280°C, 10s

2.2 Materials

Contact body and contact pin	Machined brass, plating 5 µm SnPb or 025 µm gold over 2.5 µm Ni
Contact spring	BeCu, plated 5 µm SnPb or gold (0.25 or 0.75 µm) over Ni
Insulator	Glass fibre reinforced high temperature polyester PCT, self-extinguishing UL94V-0, colour black

2.3 Mechanical Characteristics

Pin diameter	Diameter 0.43 mm
SMD solder tail	Cylindrical 0.53 mm diameter
Coplanarity SMD Terminations	0.1 mm
Mechanical life	min. 500 cycles

2.4 Electrical Characteristics

Operating voltage	50 V _{RMS} / 75 V _{DC}
Continuous operating current	max. 1 A per terminal
Contact resistance	max. 20 mΩ
Insulation resistance	10'000 MΩ (after climatic tests)
Dielectric strength	500 V _{RMS}
Air and creepage distances	min. 0.5 mm
Capacitance	max. 1 pF

3. Ordering Information

3.1 Dimensions, Order Number Codes and Packaging Information

Code for number of contacts –ONN- (Example for a 12 poles connector: -012-)

**3.1.1 Connector PN 850-PP-0NN-40-251191,
Contact Plating Code –PP-:**

- 10- Gold 0.25 um
- 90- SnPb

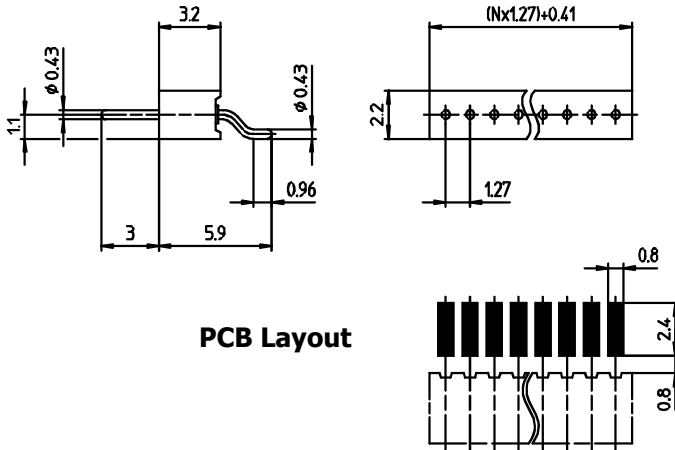

PCB Layout

Available number of pins: 6 to 12

Packaging:	6 to 8 poles	10 to 12 poles
Tape width	16 mm	24 mm
Pitch on tape	12 mm	12 mm
Reel diameter	330 mm	330 mm
Number of pcs per reel:	2000	2000
Number of pcs per box:	10'000	6000

3.1.2 Receptacle Connector PN 851-PP-0NN-40-252191

Contact Plating Code –PP-:

- | | body | spring |
|------|-------------|---------------|
| -91- | SnPb | Gold 0.25 um |
| -93- | SnPb | Gold 0.75 um |
| -99- | SnPb | SnPb |

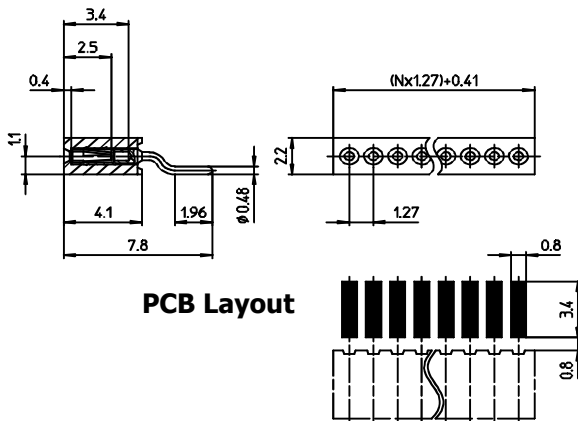

PCB Layout

Available number of pins: 6 to 12

Packaging:	6 to 8 poles	10 to 12 poles
Tape width	16 mm	24 mm
Pitch on tape	12 mm	12 mm
Reel diameter	330 mm	330 mm
Number of pcs per reel:	2000	2000
Number of pcs per box:	10'000	6000

3.2 Availability

Now

PCB Connector Strip 2 mm SMD for automatic assembly Series 831

1. Description and general features

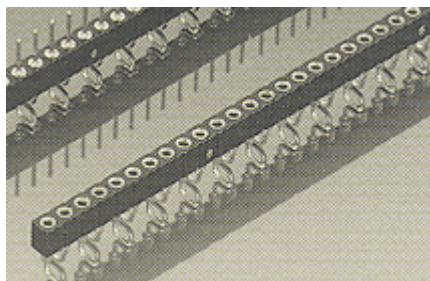

1.1 General description

The 2 mm receptacle connectors for SMD mount Series 831-...-30-001191 are now available from PRECI-DIP with Tape & Reel packaging acc. to EIA 481 Standard and with removable plastic cap for automatic assembly on the PCB.

They come in single row version with min. 3 and max. 16 poles.

The max. number of poles is given by the coplanarity limitations and the width of the existing tape 44 mm.

1.2 Advantages

With the additional plastic cap, automatic assembly with standard vacuum nozzle is made possible.

1.3 Applications

Specially recommended for high volume applications on automatic PCB assembly lines.

1.4 Optional versions

Same connector strips also available without Tape & Reel packaging and plastic cap, please see PRECI-DIP catalogue 10.

2. Technical Specifications

2.1 Environmental

Operating temperature	-55 ... + 125°C
Climatic Category (IEC)	55 / 125 / 21
Solderability	235°C, 5s
Resistance to soldering heat	280°C, 10s

2.2 Materials

Contact body	Machined brass, plating 5 µm SnPb over 2.5 µm Ni
Contact spring	BeCu, plated 5 µm SnPb or gold (0.25 or 0.75 µm) over Ni
Insulator	Glass fibre reinforced high temperature polyester PCT, self-extinguishing UL94V-0, colour black

2.3 Mechanical Characteristics

Accepts pins	Diameter 0.40 to 0.56 mm and 0.50 mm square
SMD solder tail	Cylindrical 0.53 mm diameter
Coplanarity SMD Terminations	0.1 mm (0.15 mm for connectors with more than 25 mm total length)
Mechanical life	min. 500 cycles

2.4 Electrical Characteristics

Operating voltage	100 V _{RMS} / 150 V _{DC}
Continuous operating current	max. 1 A per terminal
Contact resistance	max. 10 mΩ
Insulation resistance	10'000 MΩ (after climatic tests)
Dielectric strength	1000 V _{RMS}
Air and creepage distances	min. 0.5 mm
Capacitance	max. 1 pF

3. Ordering Information

3.1 Dimensions, Order Number Codes and Packaging Information

Contact Plating Code –PP-:	body	spring
-91-	SnPb	Gold 0.25 um
-93-	SnPb	Gold 0.75 um
-99-	SnPb	SnPb

Code for number of contacts –ONN- or (Example for 12 poles connector: -012-)

3.1.1 Connector PN 831-PP-0NN-30-001191,

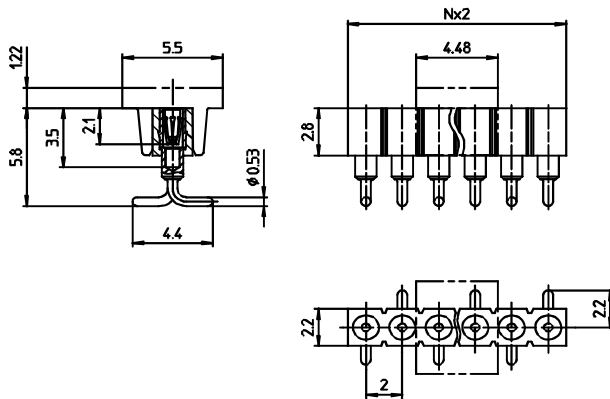

Available number of pins: 3 to 16

Packaging:
Tape width 44 mm
Pitch on tape 12 mm
Reel diameter 330 mm
Number of pcs per reel: 750
Number of pcs per box: 3000

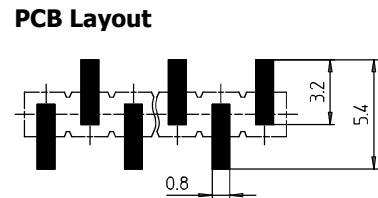

3.2 Availability

Now

2 mm polarised Socket Connector with precision machined Contacts Series 831 and 833

1. Description and general features

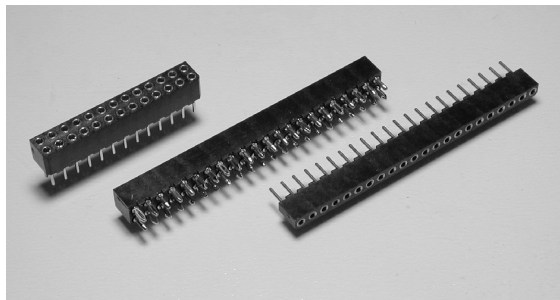

1.1 General description

The series 831 and 833 polarised metric socket connectors, introduced by PRECI-DIP to complete its comprehensive range of PCB connectors with 2 mm pitch, are equipped with machined pins. Polarisation is given, when mated with the corresponding shrouded pin connector Series 830 and 832, by the asymmetric form of the insulator body.

They are available today in single row version with 22 poles and in double row version with 26 and 44 poles.

The terminations are straight through hole solder pins, SMD pads, and solderless compliant press-fit pins.

1.2 Advantages

This socket connectors have same characteristics as the standard metric ones presented in Preci-Dip catalog No 10 with additional advantages of polarisation and easier mating.

1.3 Applications

Specially recommended for miniature applications with limited available space and demanding mechanical requirements. Design helps connector mating in place with no direct sight on the connector, such as:

- Equipment for industrial and process control
- Medical equipment
- Automotive electronics

1.4 Optional versions

For other pin count, between min. 2 and max. 22 per row, please consult.

2. Technical Specifications

2.1 Environmental

Operating temperature	-55 ... + 125°C
Climatic Category (IEC)	55 / 125 / 21
Solderability	235°C, 5s
Resistance to soldering heat	280°C, 10s

2.2 Materials

Contact body	Machined brass, tin plating 5 µm SnPb over 2.5 µm Ni
Press-Fit contact	Machined bronze, 1-2 µm SnPb over 2.5 µm Ni
Contact spring	BeCu, plated 5 µm SnPb or gold (0.25 or 0.75 µm) over Ni
Insulator	Glass fibre reinforced liquid crystal polymer LCP, self-extinguishing UL94V-0, colour black

2.3 Mechanical Characteristics

Accepts pins	Diameter 0.40 to 0.56 mm, or square pins 0.5 x 0.5 mm
Solder tail	Cylindrical, diameter 0.53 mm
Mechanical life	min.500 cycles
Coplanarity SMD terminations	0.1 mm (0.15 mm for connectors with more than 25 mm total length)

2.4 Electrical Characteristics

Operating voltage	100 V _{RMS} / 150 V _{DC}
Continuous operating current	max. 3 A per terminal
Contact resistance	max 10 mΩ
Insulation resistance	10'000 MΩ (after climatic tests)
Dielectric strength	700 V _{RMS}
Air and creepage distances	0.50 mm
Capacitance	1 pF max.

3. Ordering Information

3.1 Dimensions, Order Code Numbers and Packaging Information

Contact Plating Code -PP-:	-91-	Body: tin, Clip: gold 0.25 um
	-93-	Body: tin, Clip: gold 0.75 um
	-99-	Body and Clip: tin

Code for number of contacts –0NN-: (example for a 26 poles connector: -026-)

Packaging: **Standard packaging:** in box: replace xxx by suffix 101 to part number
Tape & Reel packaging: with plastic cap for automatic assembly with vacuum nozzle available on request for SMD mount version only (min. quantity 10'000 pcs): replace xxx by suffix 191 to part number

3.1.1 Socket Connector, single row, straight solder pin, PN 831-PP-0NN-10-242xxx

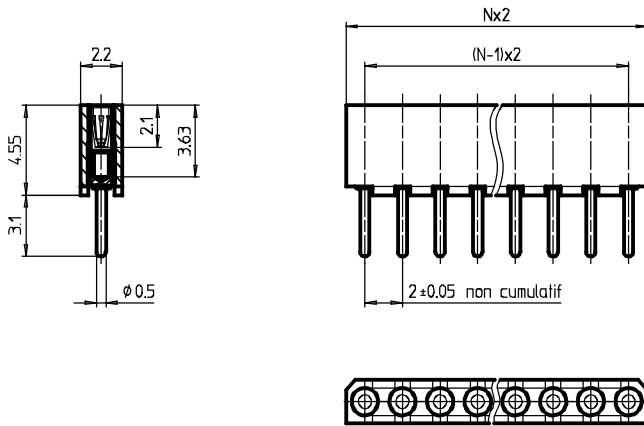

Available number of pins: 22

3.1.2 Socket Connector, double row, straight solder pin, PN 833-PP-0NN-10-245xxx

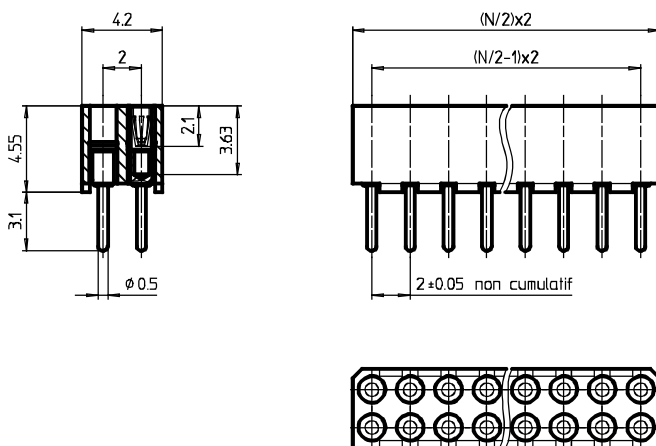

Available number of pins: 26 and 44

3.1.3 Socket Connector, single row, SMD vertical mount, PN 831-PP-0NN-30-242xxx

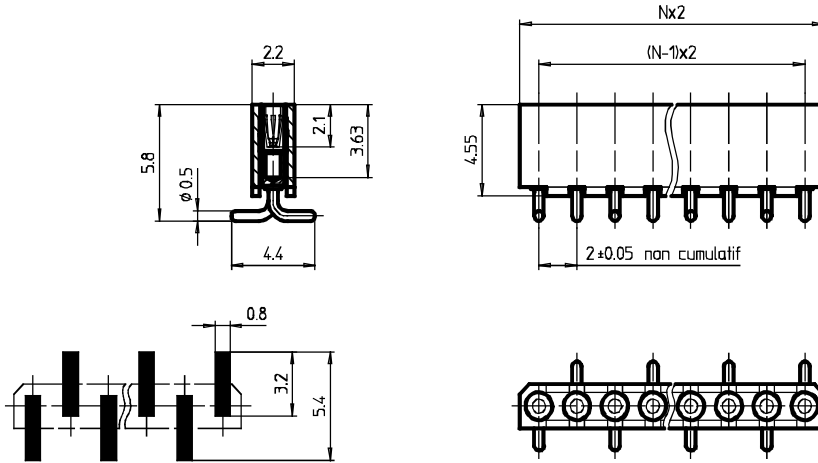

Available number of pins: 22

PCB layout

3.1.4 Socket connector, double row, SMD mount, PN 833-PP-0NN-30-245xxx

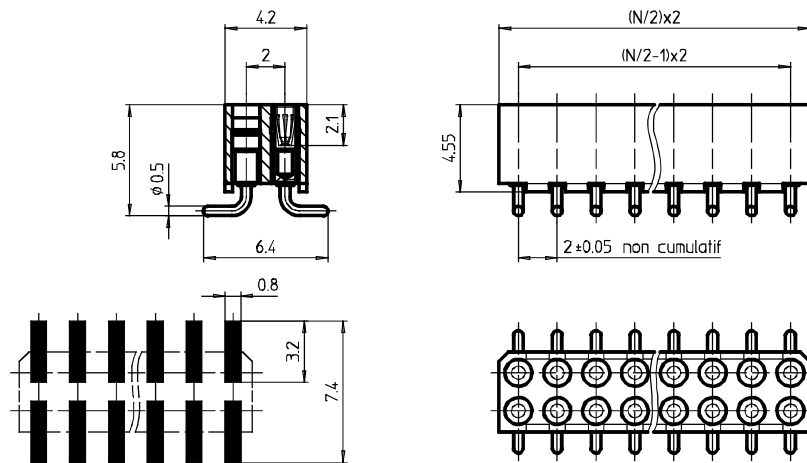

Available number of pins: 26 and 44

PCB layout

3.1.5 Socket Connector, single row, press-fit mount, PN 831-PP-0NN-64-242xxx

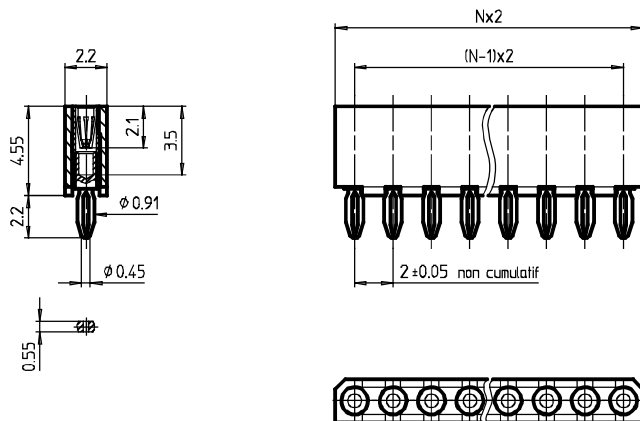

PCB and plated-through hole requirements:

- PCB material Epoxy glass laminate
FR4 or equivalent
- Thickness 1.5 to 2 mm
- Hole diameter 0.71 mm +/- 0.06 mm
- Hole metallisation min. 5 um SnPb over
min. 25 um Cu

Available number of pins: 22

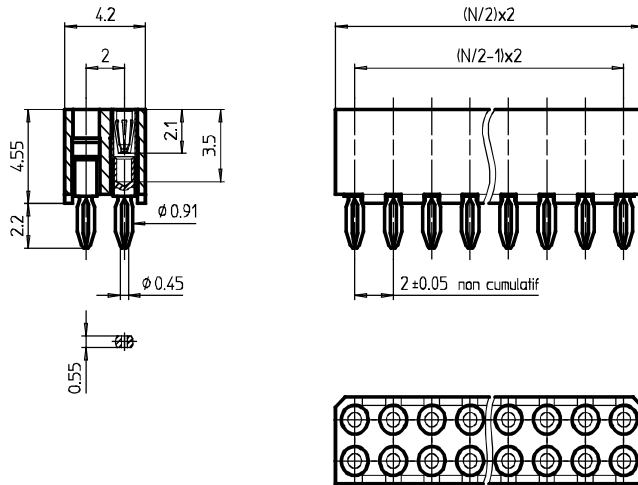
3.1.6 Socket Connector, double row, press-fit mount, PN 833-PP-0NN-64-245xxx**PCB and plated-through hole requirements:**

- PCB material Epoxy glass laminate FR4 or equivalent
- Thickness 1.5 to 2 mm
- Hole diameter 0.71 mm +/- 0.06 mm
- Hole metallisation min. 5 um SnPb over min. 25 um Cu

Available number of pins: 26 and 44**3.2 Availability**

Samples:

Second quarter 2001

Volume quantities:

Second quarter 2001

2 mm shrouded Pin Connector with Precision machined Contacts Series 830 and 832

1. Description and general features

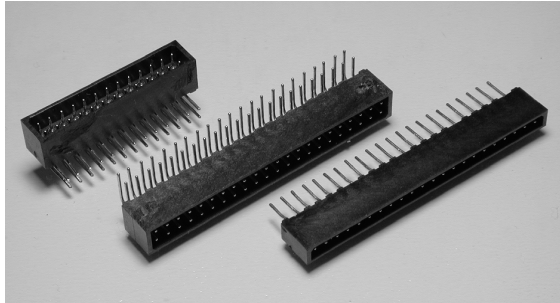

1.1 General description

The series 830 and 832 shrouded metric pin connectors, introduced by PRECI-DIP to complete its comprehensive range of PCB connectors with 2 mm pitch, are equipped with machined pins. Polarisation is given, when mated with corresponding receptacle connectors Series 831-...-242 and 833-...-245 with asymmetric form of the insulator body.

They are available today in single row version with 22 poles and in double row version with 26 and 44 poles.

The terminations are straight and right angle through hole solder pins and SMD solder pads.

1.2 Advantages

This pin connectors have all advantages of the machined pins that show a smooth surface in the contact area allowing a high mechanical life, combined with the improved mechanical characteristics of shrouded connector body.

The contacts are available with gold or tin (SnPb 90/10) plating.

1.3 Applications

Specially recommended for miniature applications with limited available space and demanding mechanical requirements. Design helps connector mating in place with no direct sight on the connector, such as:

- Equipment for industrial and process control
- Medical equipment
- Automotive electronics

1.4 Optional versions

For other pin count, between min. 2 and max. 22 per row, please consult.

2. Technical Specifications

2.1 Environmental

Operating temperature	-55 ... + 125°C
Climatic Category (IEC)	55 / 125 / 21
Solderability	235°C, 5s
Resistance to soldering heat	280°C, 10s

2.2 Materials

Contact	Machined brass, gold plated 0.25 µm Au or tin plated 5 µm SnPb over 2.5 µm Ni
Insulator	Glass fibre reinforced liquid crystal polymere LCP, self-extinguishing UL94V-0, colour black

2.3 Mechanical Characteristics

Contact pin	Cylindrical, diameter 0.47 mm
Solder tail	Cylindrical, diameter 0.50 mm
Mechanical life	min.500 cycles
Coplanarity SMD terminations	0.1 mm (0.15 mm for connectors with more than 25 mm total length)

2.4 Electrical Characteristics

Operating voltage	100 V _{RMS} / 150 V _{DC}
Continuous operating current	max. 3 A per terminal
Insulation resistance	10'000 MΩ (after climatic tests)
Dielectric strength	700 V _{RMS}
Air and creepage distances	min. 0.50 mm
Capacitance	max. 1 pF

3. Ordering Information

3.1 Dimensions, Order Code Numbers and Packaging Information

Contact Plating Code -PP-: **-10-** **Gold 0.25 um**
 -90- **Tin**

Code for number of contacts –0NN-: (example for a 26 poles connector: -026-)

Packaging: **Standard packaging:** in box: replace xxx by suffix 101 to part number
 Tape & Reel packaging: with plastic cap for automatic assembly with vacuum nozzle available on request for SMD mount version only (min. quantity 10'000 pcs): replace xxx by suffix 191 to part number

3.1.1 Pin Connector, single row, straight solder pin, PN 830-PP-0NN-12-002xxx

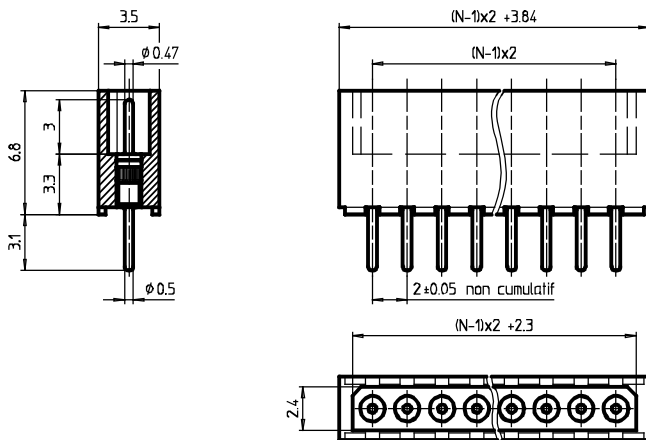

Available number of pins: 22

3.1.2 Pin Connector, double row, straight solder pin, PN 832-PP-0NN-12-002xxx

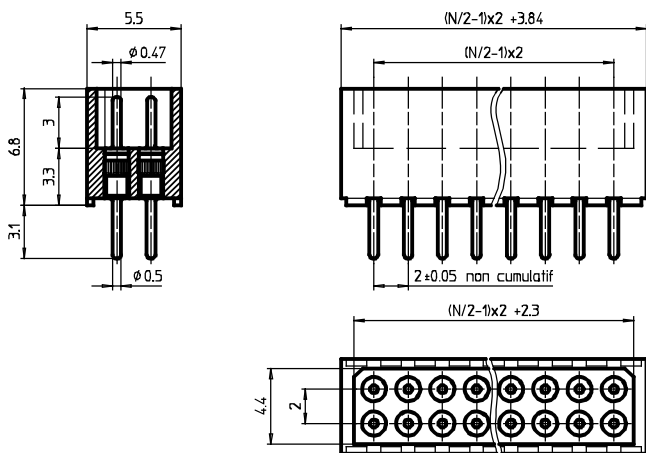

Available number of pins: 26 and 44

3.1.3 Pin Connector, single row, right angle solder pin, PN 830-PP-0NN-22-002xxx

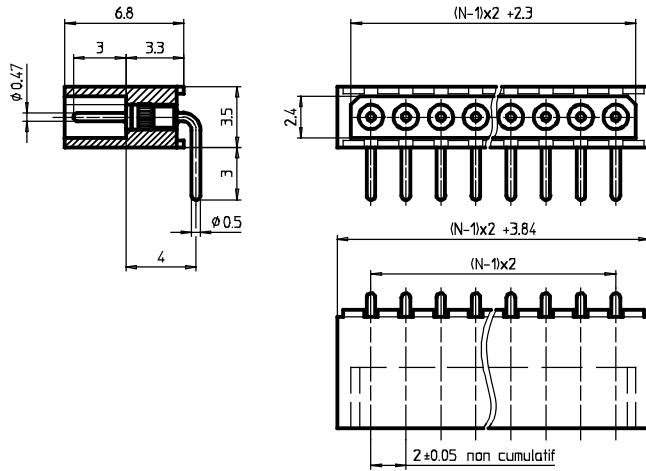

Available number of pins: 22

3.1.4 Pin Connector, double row, right angle solder pin, PN 832-PP-0NN-22-002xxx

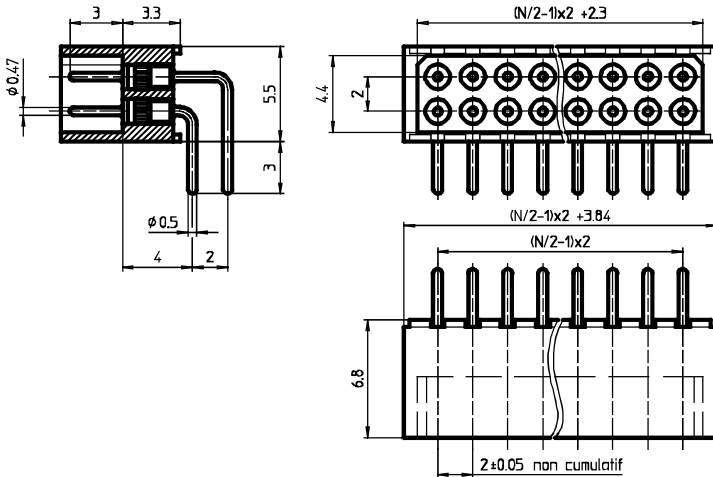

Available number of pins: 26 and 44

3.1.5 Pin Connector, single row, SMD vertical mount, PN 830-PP-0NN-32-002xxx

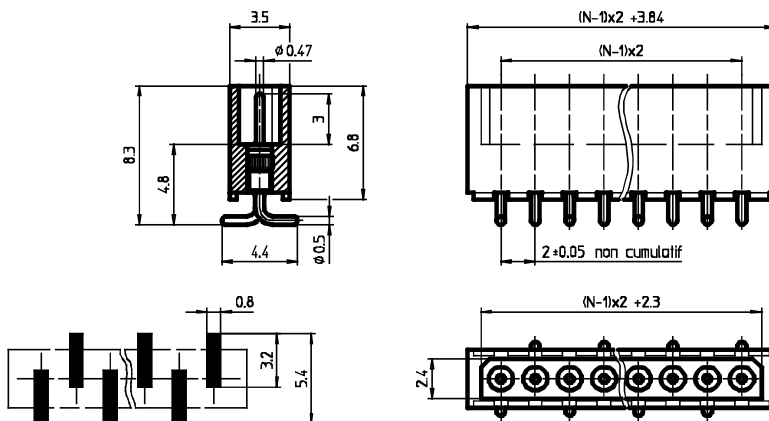

Available number of pins: 22

PCB layout

3.1.6 Pin Connector, double row, SMD vertical mount, PN 832-PP-0NN-32-002xxx

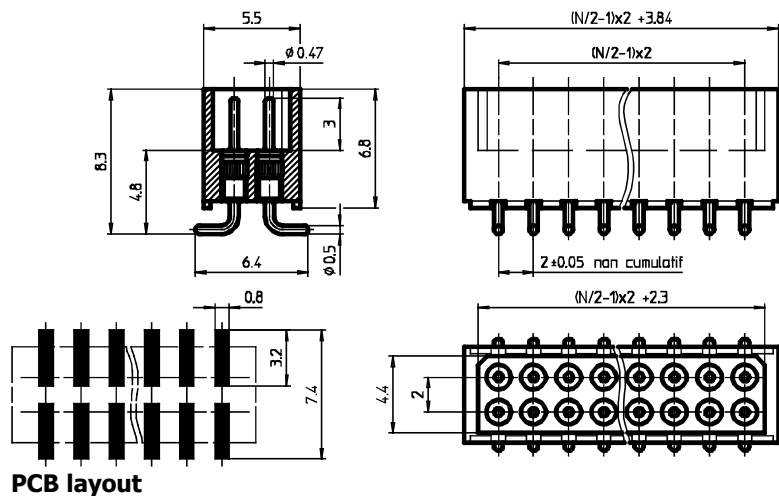

Available number of pins: 26 and 44

3.2 Availability

Samples: Second quarter 2001
Volume quantities: Second quarter 2001

PCB Connector Strip 2.54 mm SMD for automatic assembly Series 310 and 410

1. Description and general features

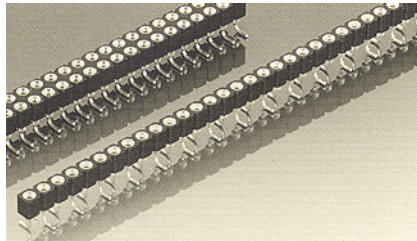

1.1 General description

The Series 310-... , 410-...-105191 and 310-...-205191 receptacle connectors for SMD mount are now available from PRECI-DIP with Tape & Reel packaging acc. to EIA 481 Standard. The vertical mount series with PN ending with -105191 are with removable plastic cap for automatic assembly on the PCB. The horizontal mount series, with PN ending with -205191, are with a specific insulator without notch on the upper side.

They come in single row version with min 2 (min 3 poles for vertical mount version) to max 12 poles, and in double row version (only vertical mount) with min 10 and max 34 poles.

The max. possible number of poles is given by the coplanarity limitations and the tape width of 56 mm, maximum size that PRECI-DIP can process.

1.2 Advantages

With the specific insulator or the additional plastic cap, automatic assembly with standard vacuum nozzle is made possible.

1.3 Applications

Specially recommended for high volume applications on automatic PCB assembly lines.

1.4 Optional versions

Same connector strips also available without Tape & Reel packaging and plastic cap, please see PRECI-DIP catalogue 10.

2. Technical Specifications

2.1 Environmental

Operating temperature	-55 ... + 125°C
Climatic Category (IEC)	55 / 125 / 21
Solderability	235°C, 5s
Resistance to soldering heat	280°C, 10s

2.2 Materials

Contact body	Machined brass, plating 5 µm SnPb over 2.5 µm Ni
Contact spring	BeCu, plated 5 µm SnPb or gold (0.1, 0.25 or 0.75 µm) over Ni
Insulator	Glass fibre reinforced high temperature polyester PCT, self-extinguishing UL94V-0, colour black

2.3 Mechanical Characteristics

Accepts pins	Diameter 0.45 to 0.56 mm
SMD solder tail	Cylindrical 0.52 mm diameter
Coplanarity SMD Terminations	0.1 mm (0.15 mm for connectors with more than 25 mm total length)
Mechanical life	min. 500 cycles

2.4 Electrical Characteristics

Operating voltage	100 V _{RMS} / 150 V _{DC}
Continuous operating current	max. 1 A per terminal
Contact resistance	max. 10 mΩ
Insulation resistance	10'000 MΩ (after climatic tests)
Dielectric strength	1000 V _{RMS}
Air and creepage distances	min. 0.7 mm
Capacitance	max. 0.3 pF

3. Ordering Information

3.1 Dimensions, Order Number Codes and Packaging Information

Contact Plating Code –PP-:	body	spring
-91-	SnPb	Gold 0.25 um
-93-	SnPb	Gold 0.75 um
-97-	SnPb	Flash gold
-99-	SnPb	SnPb

Code for number of contacts –1NN- or -2NN- (Example for a single row 12 poles connector: -112-)

3.1.1 Connector PN 310-PP-1NN-01-105191

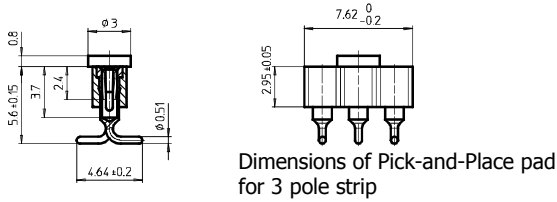

Available number of pins: 3 to 12
Packaging:

	3 poles	4 to 9 poles	10 to 17 poles
Tape width	16 mm	32 mm	56 mm
Pitch on tape	12 mm	12 mm	12 mm
Reel diameter	330 mm	330 mm	330 mm
Number of pcs per reel:	850	650	650
Number of pcs per box:	4250	1950	1950

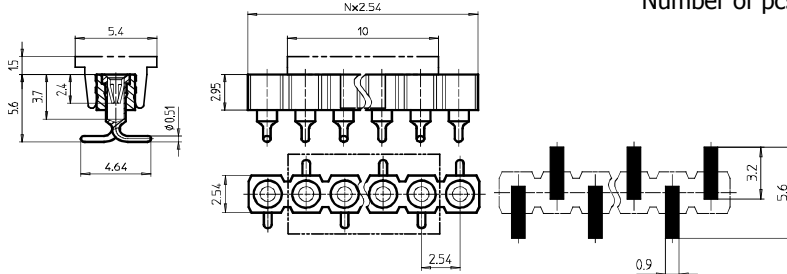

3.1.2 Connector PN 310-PP-1NN-41-205191

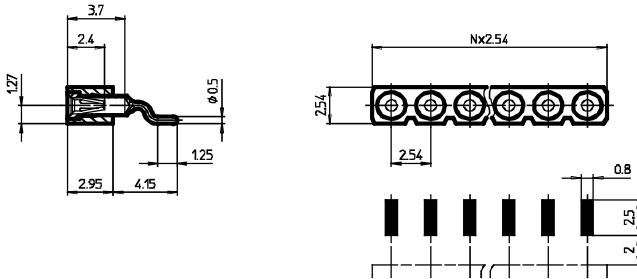

Available number of pins: 2 to 8
Packaging:

Tape width	32 mm
Pitch on tape	16 mm
Reel diameter	330 mm
Number of pcs per reel:	1500
Number of pcs per box:	4500

PCB Layout

3.1.3 Connector PN 410-PP-2NN-41-105191

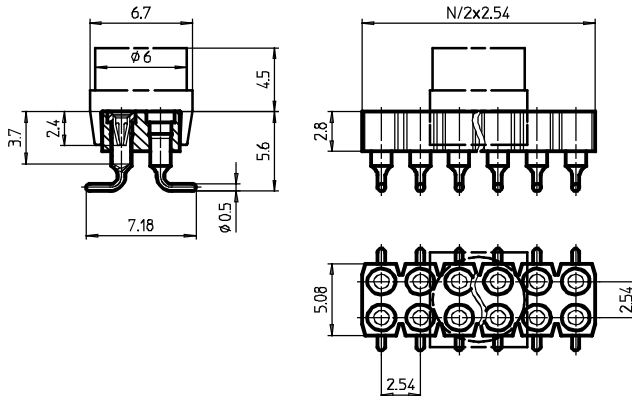

Available number of pins: 10 to 34
Packaging:

Tape width	56 mm
Pitch on tape	16 mm
Reel diameter	330 mm
Number of pcs per reel:	350
Number of pcs per box:	1050

PCB Layout

3.2 Availability

Now

Preci-Dip Durtal SA

CH-2800 Delémont / Switzerland
phone +41 (32) 421 04 00 - fax +41 (32) 421 04 01
mail:sales@precidip.com – www.precidip.com

PCB Connector Strip 2.54 mm SMD for automatic assembly Series 801 and 803

1. Description and general features

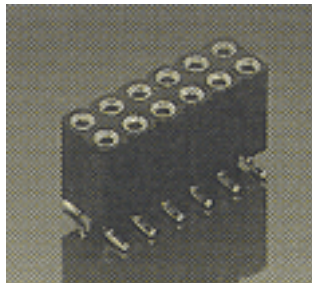

1.1 General description

The SMD receptacle connectors Series 801 / 803 are now available from PRECI-DIP with Tape & Reel packaging acc. to EIA 481 Standard.

The horizontal mount Series 801-...-40-001191 are with a specific insulator without notch on the upper side, and the vertical mount Series 803-...-30-001191 (height over PCB = 8.6 mm) and 803-...-30-002191 (height over PCB = 5.6 mm) are with removable plastic cap for automatic assembly on the PCB.

They come in single row version from min. 2 to max. 8 poles and in double row version with min. 10 and max. 34 poles.

The max. possible number of poles is given by the coplanarity limitations and the tape width of 56 mm, maximum size that PRECI-DIP can process.

1.2 Advantages

With the specific insulator body or the additional plastic cap, automatic assembly with standard vacuum nozzle is made possible.

1.3 Applications

Specially recommended for high volume applications on automatic PCB assembly lines.

1.4 Optional versions

Same connector strips also available without Tape & Reel packaging and plastic cap, please see PRECI-DIP catalogue 10.

2. Technical Specifications

2.1 Environmental

Operating temperature	-55 ... + 125°C
Climatic Category (IEC)	55 / 125 / 21
Solderability	235°C, 5s
Resistance to soldering heat	280°C, 10s

2.2 Materials

Contact body	Machined brass, plating 5 µm SnPb over 2.5 µm Ni
Contact spring	BeCu, plated 5 µm SnPb or gold (0.25 or 0.75 µm) over Ni
Insulator	Glass fibre reinforced high temperature polyester PCT, self-extinguishing UL94V-0, colour black

2.3 Mechanical Characteristics

Accepts pins	Diameter 0.70 to 0.80 mm and 0.635 mm square
SMD solder tail	Cylindrical 0.60 mm diameter
Coplanarity SMD Terminations	0.1 mm (0.15 mm for connectors with more than 25 mm total length)
Mechanical life	min. 500 cycles

2.4 Electrical Characteristics

Operating voltage	100 V _{RMS} / 150 V _{DC}
Continuous operating current	max. 3 A per terminal
Contact resistance	max. 10 mΩ
Insulation resistance	10'000 MΩ (after climatic tests)
Dielectric strength	1000 V _{RMS}
Air and creepage distances	min. 0.7 mm
Capacitance	max. 0.3 pF

3. Ordering Information

3.1 Dimensions, Order Number Codes and Packaging Information

Contact Plating Code –PP-:	body	spring
-91-	SnPb	Gold 0.25 um
-93-	SnPb	Gold 0.75 um
-99-	SnPb	SnPb

Code for number of contacts –ONN- (Example for 12 poles connector: -012-)

3.1.1 Connector PN 801-PP-0NN-40-001191

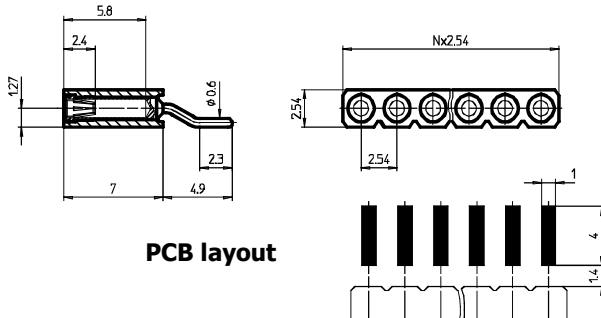

PCB layout

Available number of pins: 2 to 8

Packaging:
Tape width 32 mm
Pitch on tape 16 mm
Reel diameter 330 mm
Number of pcs per reel: 1300
Number of pcs per box: 3900

3.1.2 Connector PN 803-PP-0NN-30-001191

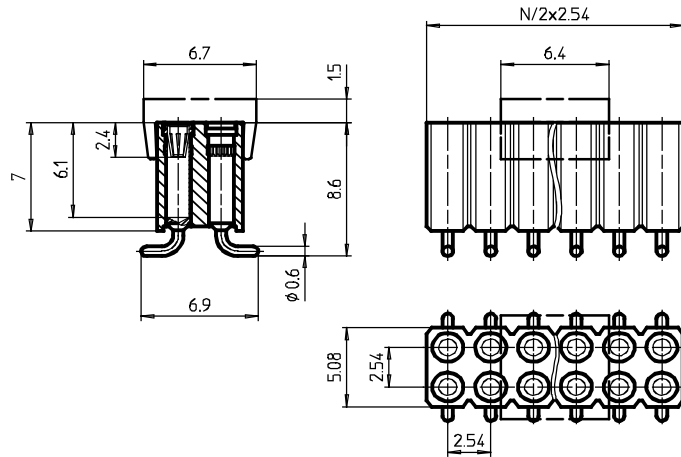

PCB layout

Available number of pins: 10 to 34

Packaging:
Tape width 56 mm
Pitch on tape 16 mm
Reel diameter 330 mm
Number of pcs per reel: 350
Number of pcs per box: 1050

3.1.3 Connector PN 803-PP-0NN-30-002191

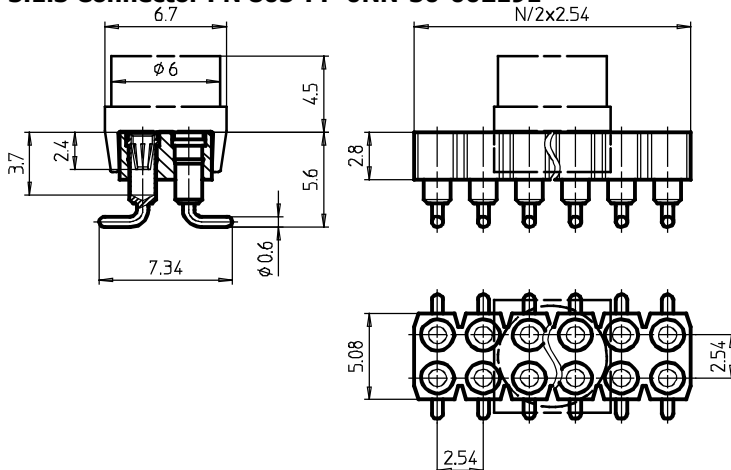

PCB layout

Available number of pins: 10 to 34

Packaging:
Tape width 56 mm
Pitch on tape 16 mm
Reel diameter 330 mm
Number of pcs per reel: 350
Number of pcs per box: 1050

3.2 Availability

Now

Preci-Dip Durtal SA

CH-2800 Delémont / Switzerland
phone +41 (32) 421 04 00 - fax +41 (32) 421 04 01
mail:sales@precidip.com – www.precidip.com

Pin Connector with Precision machined Contacts for SMD mount Series 350

1. Description and general features

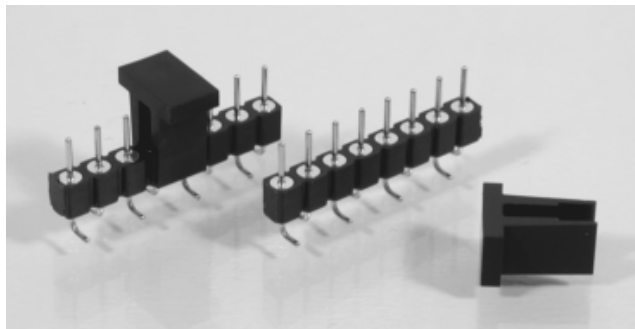

1.1 General description

The Series 350-...-106191 receptacle connectors for vertical SMD mount are now available from PRECI-DIP with Tape & Reel packaging acc. to EIA 481 Standard, and with removable plastic cap for automatic assembly on the PCB.

They come with min 3 poles to max 10 poles. The max. possible number of poles is given by the coplanarity limitations and the tape width of 56 mm, maximum size that PRECI-DIP can process. Further to gold and tin plated version, the connectors are available with Preci-Dip original Bi-Bloc selective plated contacts.

1.2 Advantages

With the additional plastic cap, automatic assembly with standard vacuum nozzle is made possible.

1.3 Applications

Specially recommended for high volume applications on automatic PCB assembly lines.

1.4 Optional versions

Same connector strips also available without Tape & Reel packaging and plastic cap, please see PRECI-DIP catalogue 10.

2. Technical Specifications

2.1 Environmental

Operating temperature	-55 ... + 125°C
Climatic Category (IEC)	55 / 125 / 21
Solderability	235°C, 5s
Resistance to soldering heat	280°C, 10s

2.2 Materials

Contact	Machined brass, gold plated 0.25 µm Au or tin plated 5 µm SnPb over 2.5 µm Ni
Insulator	Glass fibre reinforced high temperature polyester PCT, self-extinguishing UL94V-0, colour black

2.3 Mechanical Characteristics

Contact pin	Cylindrical, diameter 0.47 mm
Solder tail	Cylindrical, diameter 0.47 mm
Mechanical life	min.500 cycles
Coplanarity SMD terminations	0.1 mm

2.4 Electrical Characteristics

Operating voltage	100 V _{RMS} / 150 V _{DC}
Continuous operating current	max. 3 A per terminal
Insulation resistance	10'000 MΩ (after climatic tests)
Dielectric strength	10'00 V _{RMS}
Air and creepage distances	min. 0.70 mm
Capacitance	max. 0.3 pF

3. Ordering Information

3.1 Dimensions, Order Code Numbers and Packaging Information

Contact Plating Code -PP-:	-10-	Gold 0.25 um	
	-90-	Tin	
	-Z1-	Selective plating:	contacting area gold 0.25 um solder pin, body: tin

Code for number of contacts -1NN-: (example for a 6 poles connector: -106-)

3.1.1 Pin Connector, single row, straight solder pin, PN 350-PP-1NN-00-106191

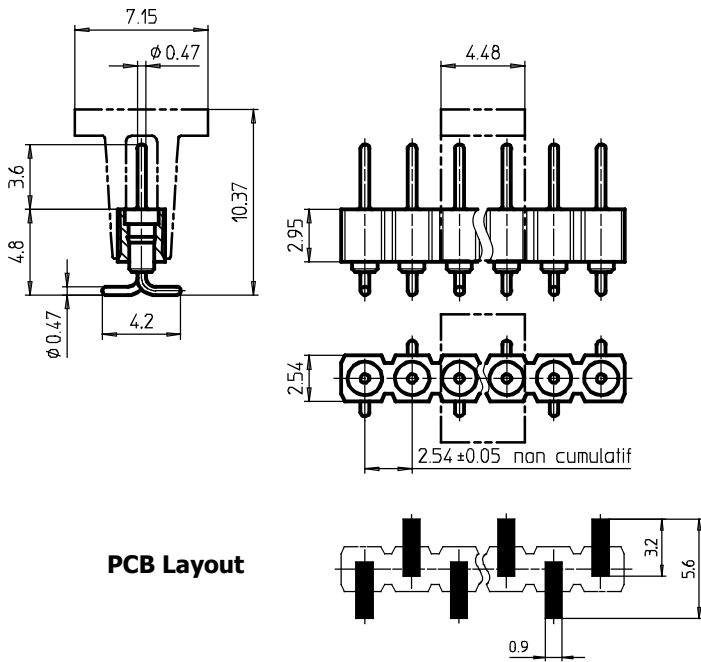

Available number of pins: 3 to 10
Packaging:

- Tape width 44 mm
- Pitch on tape 12 mm
- Reel diameter 330 mm
- Number of pcs per reel: 550
- Number of pcs per box: 1100

3.2 Availability

Now

Shrouded Pin Header/Connector with Precision Machined Contacts Series 800 to 804

1. Description and general features

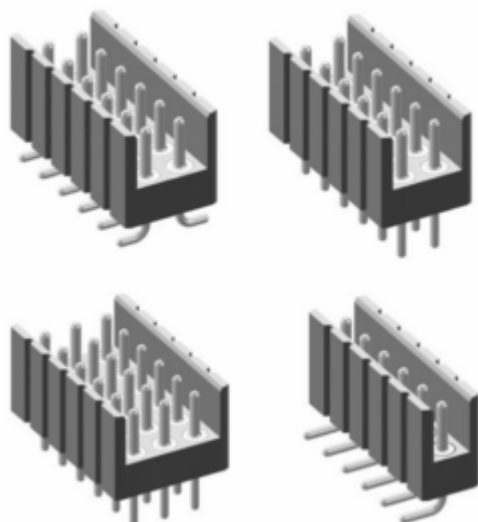

1.1 General description

The series 800 to 804 shrouded pin connectors, introduced by PRECI-DIP to complete its comprehensive range of PCB connectors with 2.54 mm pitch, are equipped with machined pins.

They come in single, double and triple row version with max 32 poles per row.

The available terminations are straight and right angle solder pins, SMD and press-fit solderless.

1.2 Advantages

This pin connectors have all advantages of the machined pins that show a smooth surface in the contact area allowing a high mechanical life, combined with the improved mechanical characteristics of shrouded connector body.

The contacts are available with the original PRECI-DIP selective plating system for machined contacts.

1.3 Applications

Specially recommended for applications with higher mechanical requirements and to help connector mating in places with no direct sight on the connector, such as:

- Equipment for industrial and process control
- Medical equipment
- Automotive electronics

1.4 Optional versions

Currently none

2. Technical Specifications

2.1 Environmental

Operating temperature	-55 ... + 125°C
Climatic Category (IEC)	55 / 125 / 21
Solderability	235°C, 5s
Resistance to soldering heat	280°C, 10s (280 °c, 10 S for SMD versions)

2.2 Materials

Contact	Machined brass, 4-5 µm SnPb or 0.25 µm Au over 2.5 µm Ni
Press-Fit contact	Machined bronze, 1-2µm SnPb or 0.25 µm Au over 2.5 µm Ni
Insulator	Glass fibre reinforced high temperature polyester PCT, self-extinguishing UL94V-0, black

2.3 Mechanical Characteristics

Contact pin	Cylindrical, diameter 0.75 mm
Solder tail	Cylindrical, diameter 0.60 mm
Mechanical life	min.500 cycles
Press-Fit compliant pin	Modified "eye of the needle" for PCB holes 1 + 0.09 / - 0.04 mm

2.4 Electrical Characteristics

Operating voltage	100 V _{RMS} / 150 V _{DC}
Continuous operating current	max. 3 A per terminal
Insulation resistance	10'000 MΩ (after climatic tests)
Dielectric strength	1000 V _{RMS}
Air and creepage distances	min. 0.70 / 0.85 mm
Capacitance	max. 1 pF

3. Ordering Information

3.1 Dimensions, Order Number Codes and Packaging Information

Contact plating code –PP–:

-10- Gold 0.25 um

-90- SnPb

-Z1- selective "Bi-bloc" Gold 0.25 um contacting pin / SnPb termination

Code for number of contacts: -NNN- (example for a 50 poles connector –050–)

Packaging: Standard in box

for SMD connectors, Tape & Reel Packaging on request (min. quantity per order 10'000 pcs)

3.1.1 Pin connector, solder tail

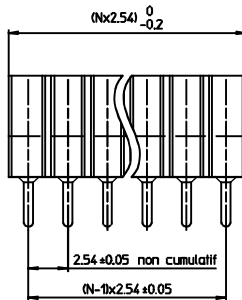
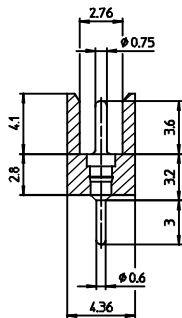

Single row PN 800-PP-NNN-12-002101

Available from 2 to 32 pins

Standard number of pins: 32

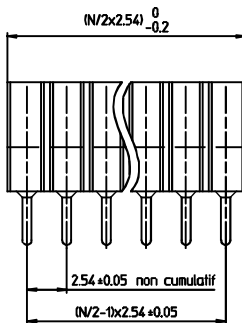
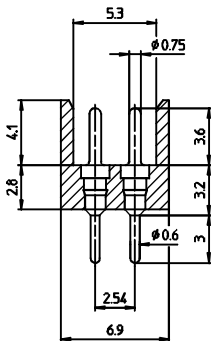

Double row PN 802-PP-NNN-12-002101

Available from 4 to 64 pins

Standard number of pins: 64

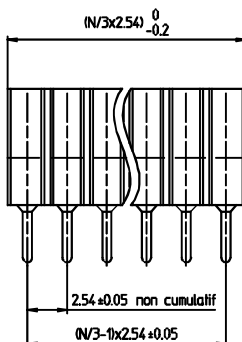
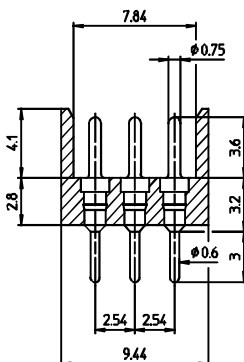

Triple row PN 804-PP-NNN-12-002101

Available from 9 to 96 pins

Standard number of pins: 96

3.1.2 Pin connector right angle solder tail

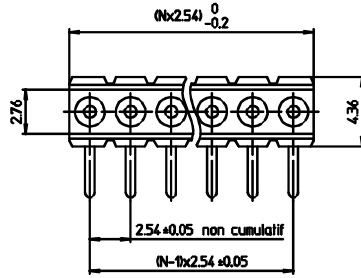
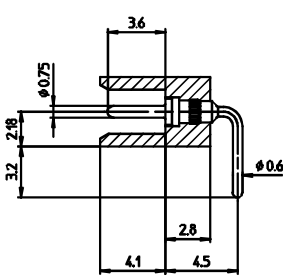

Single row PN 800-PP-NNN-22-002101

Available from 2 to 32 pins
Standard number of pins: 32

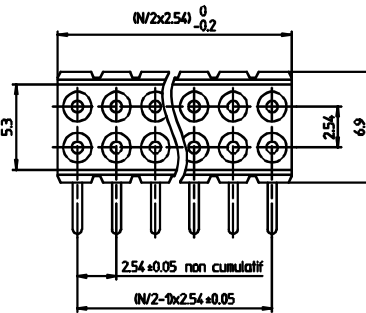
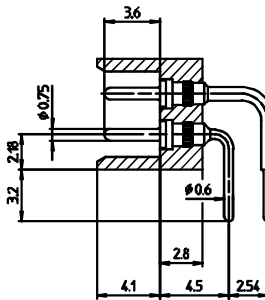

Double row PN 802-PP-NNN-22-002101

Available from 4 to 64 pins
Standard number of pins: 64

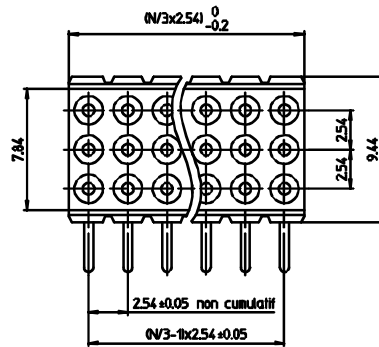
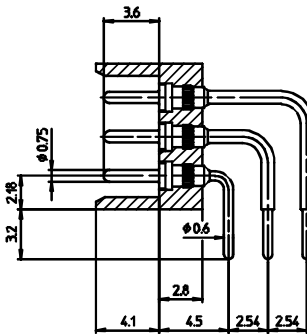

Triple row PN 804-PP-NNN-22-002101

Available from 9 to 96 pins
Standard number of pins: 96

3.1.3 Pin connector SMD vertical mount

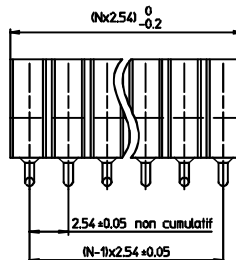
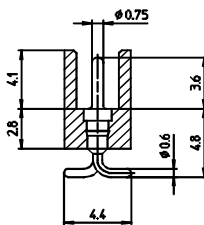

Single row PN 800-PP-NNN-32-002101

Available from 3 to 32 pins
Standard number of pins: 32

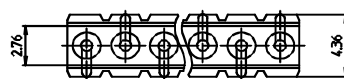

PCB Layout

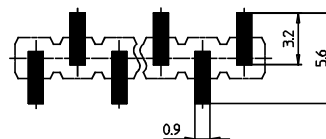

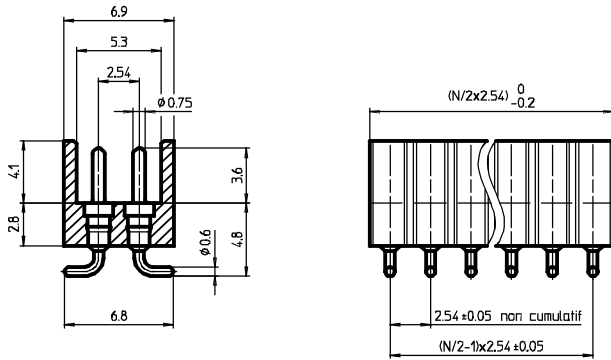

Double row PN 802-PP-NNN-32-002101

Available from 4 to 64 pins
Standard number of pins 64

PCB Layout

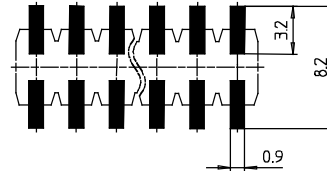

3.1.4 Pin connector Press-Fit compliant pin

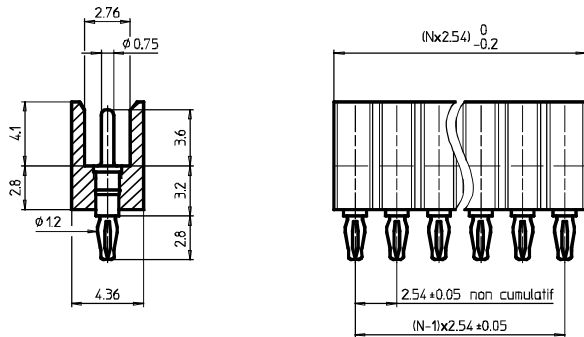

PCB and plated-through hole requirements:

- PCB Material Epoxy-glass laminate FR4 or equivalent
- Thickness 1.5 to 2 mm
- Hole diameter 1 mm + 0.09/-0.06 mm
- Hole metallisation min. 5 um SnPb over min. 25 um Cu

Single row PN 800-PP-NNN-6B-002101

Available from 2 to 32 pins
Standard number of pins 32

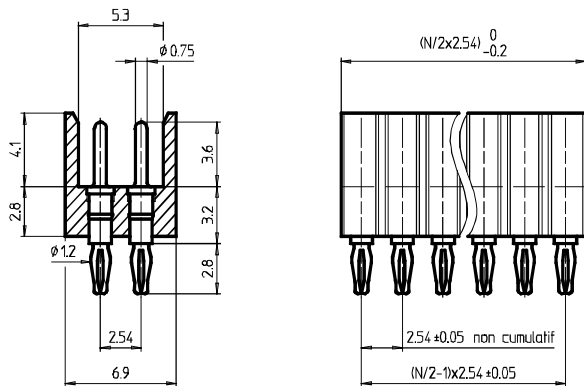

Double row PN 802-PP-NNN-6B-002101

Available from 4 to 64 pins
Standard number of pins 64

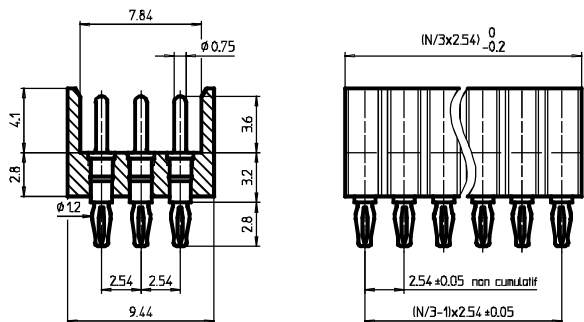

Triple row PN 804-PP-NNN-6B-002101

Available from 9 to 96 pins
Standard number of pins 96

3.2 Availability

Now

Preci-Dip Durtal SA

CH-2800 Delémont / Switzerland
phone +41 (32) 421 04 00 - fax +41 (32) 421 04 01
mail:sales@precidip.com - www.precidip.com

DIL socket SMD for automatic assembly Series 110 and 114

1. Description and general features

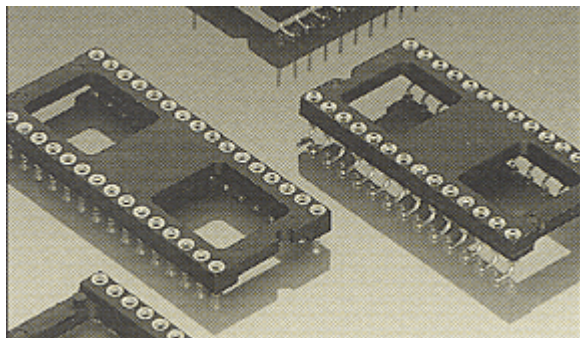

1.1 General description

The DIL sockets for SMD mount Series 110-...-105191 (with "gull wing" terminations) and 114-...-134191 (with floating pin design) are now available from PRECI-DIP with Tape & Reel packaging acc. to EIA 481 Standard for automatic assembly on the PCB.

The Series 110 come with min. 8 and max. 20 poles and row distance .3" (7.62 mm). The Series 114 come with 8 to 28 poles for row distance .3" (7.62 mm) and 28 poles for row distance .6" (15.24 mm).

The max. possible number of poles is given, for the Series 110 by the coplanarity limitations, and for the Series 114 by the tape width of 56 mm, maximum size that PRECI-DIP can process.

1.2 Advantages

The plastic body with the wide center bar, placed at the top of the socket, is optimised for automatic assembly with standard vacuum nozzle.

1.3 Applications

Specially recommended for high volume applications on automatic PCB assembly lines.

1.4 Optional versions

Same sockets also available without Tape & Reel packaging, please see PRECI-DIP catalogue 10.

2. Technical Specifications

2.1 Environmental

Operating temperature	-55 ... + 125°C
Climatic Category (IEC)	55 / 125 / 21
Solderability	235°C, 5s
Resistance to soldering heat	280°C, 10s

2.2 Materials

Contact body	Machined brass, plating 5 µm SnPb over 2.5 µm Ni
Contact spring	BeCu, plated 5 µm SnPb or gold (0.1, 0.25 or 0.75 µm) over Ni
Insulator	Glass fibre reinforced high temperature polyester PCT, self-extinguishing UL94V-0, colour black

2.3 Mechanical Characteristics

Accepts pins	Diameter 0.40 to 0.56 mm
SMD solder tail	Gull wing: cylindrical 0.52 mm diameter Floating pin: diameter 1 mm
Coplanarity SMD Terminations	Gull wing: 0.1 mm The floating pins are self-aligning within 0.3 mm to the surface of the PCB
Mechanical life	min. 500 cycles

2.4 Electrical Characteristics

Operating voltage	100 V _{RMS} / 150 V _{DC}
Continuous operating current	max. 1 A per terminal
Contact resistance	max. 10 mΩ
Insulation resistance	10'000 MΩ (after climatic tests)
Dielectric strength	1000 V _{RMS}
Air and creepage distances	min. 0.6 mm
Capacitance	max. 0.3 pF

3. Ordering Information

3.1 Dimensions, Order Number Codes and Packaging Information

Contact Plating Code –PP-:	body	spring
-91-	SnPb	Gold 0.25 um
-93-	SnPb	Gold 0.75 um
-99-	SnPb	SnPb

3.1.1 SMD socket Gull-wing PN 110-PP-3NN-41-105191

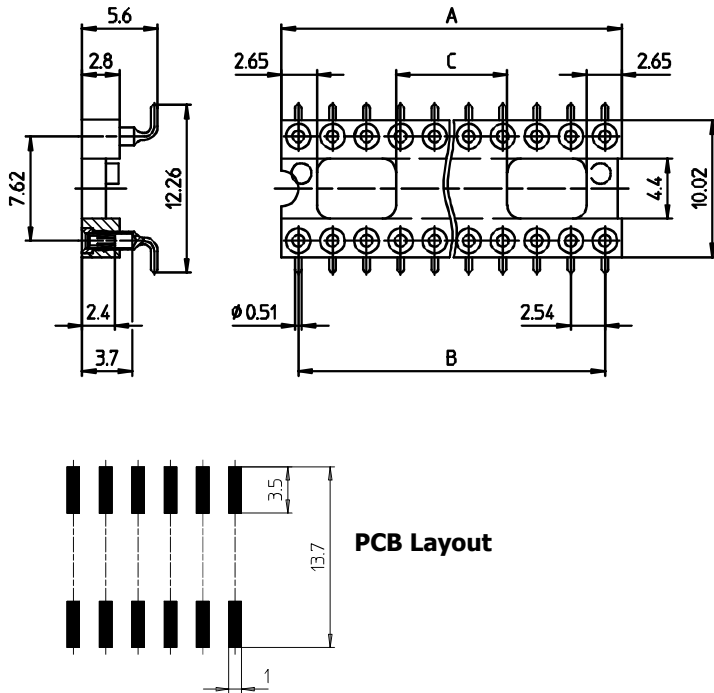

Available number of pins: 8, 14, 16, 18 and 20

Code Number of Contacts –3NN-

Dimensions[mm]:

Number of pins	A	B	C
308	10.1	3 x 2.54	10.1
314	17.8	6 x 2.54	5.3
316	20.3	7 x 2.54	5.3
318	22.9	8 x 2.54	5.3
320	25.4	9 x 2.54	8.3

Packaging:

	308	314 to 320
Tape width	24 mm	44 mm
Pitch on tape	16 mm	20 mm
Reel diameter	330 mm	330 mm
Number of pcs per reel:	700	550
Number of pcs per box:	2100	2200

3.1.2 SMD socket floating-pin PN 114-PP-3NN-41-134191

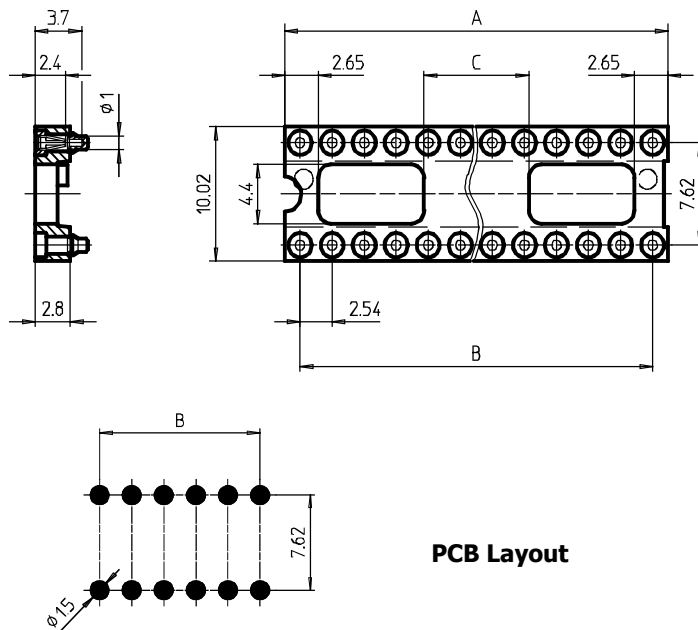

Available number of pins: 8, 14, 16, 18, 20, 24 and 28

Code Number of Contacts –3NN-

Dimensions[mm]:

Number of pins	A	B	C
308	10.1	3 x 2.54	10.1
314	17.8	6 x 2.54	5.3
316	20.3	7 x 2.54	5.3
318	22.9	8 x 2.54	5.3
320	25.4	9 x 2.54	8.3
324	30.4	11 x 2.54	8.3
328	35.6	13 x 2.54	8.3

Packaging:

	308 to 328
Tape width	56 mm
Pitch on tape	16 mm
Reel diameter	330 mm
Number of pcs per reel:	800
Number of pcs per box:	2400

3.13 SMD socket floating pin PN 114-PP-6NN-41-134191

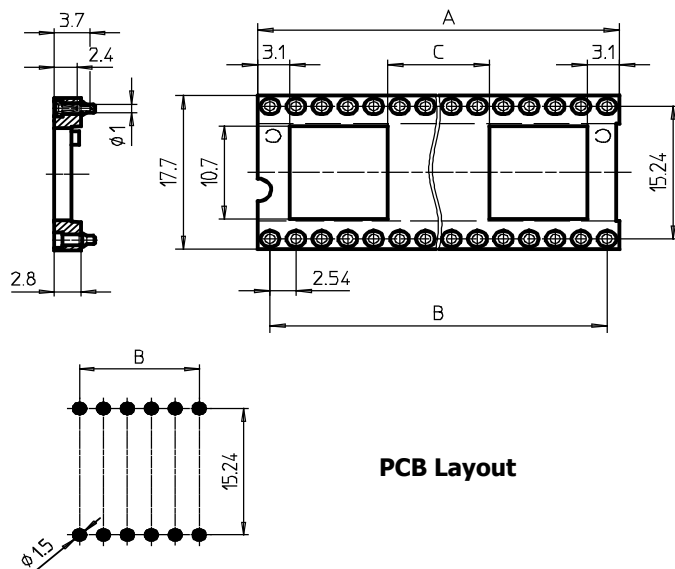

PCB Layout

Available number of pins: 28

Code Number of Contacts –6NN–

Dimensions[mm]:

Number of pins	A	B	C
628	35.5	13 x 2.54	10

Packaging:

- Tape width 56 mm
- Pitch on tape 24 mm
- Reel diameter 330 mm
- Number of pcs per reel: 400
- Number of pcs per box: 1200

3.2 Availability

Now

SMD Sockets for interstitial Pin Grid Arrays Series 514-...154

1. Description and general features

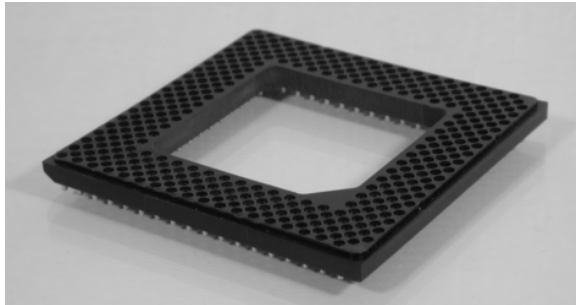

1.1 General description

Interstitial PGA sockets come with floating SMD contacts which are self-adjusting with the solder pads, even with slightly distorted PCBs.

The contact diameter at the soldering end is 0.8 mm, allowing solder pads of 0.9 mm diameter which leaves sufficient space between the connections for the conductive paths of the circuit.

1.2 Advantages

Interstitial PGA sockets are adapted to new Pin Grid Array microcircuit packages with high contact density and make an optimal interface connection to SMD PCBs, avoiding the combination of SMD components with parts requiring through hole connections on the same circuit. This greatly improves the efficiency of the assembling and soldering processes.

1.3 Applications

SMD printed circuit assemblies of all kinds requiring integration of components having PGA packages. Specially recommended for manufacturing equipment with high production rates.

1.4 Optional versions

Optional version with positioning pins available on request

2. Technical Specifications

2.1 Environmental

Operating temperature	-55 ... + 125°C
Climatic Category (IEC)	55 / 125 / 21
Solderability	235°C, 10s
Resistance to soldering heat	280°C, 10s

2.2 Materials

Contact body	Machined brass, plating 5 µm SnPb over 2.5 µm Ni
Contact spring	BeCu, gold plated (0.1, 0.25 or 0.75 µm) over Ni
Insulator	Glass fibre reinforced high temperature polyester PCT, self-extinguishing UL94V-0, colour black

2.3 Mechanical Characteristics

Insertion force (initial)	0.6 N max. / 0.35 N typical, with polished steel gauge Ø 0.46 mm
Withdrawal force (initial)	0.15 N min / 0.2 N typical with polished steel gauge Ø 0.46 mm
Contact spring (clip) retention	40 N minimum
Mechanical life	100 cycles

2.4 Electrical Characteristics

Operating voltage	100 V _{RMS} / 150 V _{DC}
Continuous operating current	max. 1 A per terminal
Contact resistance	max. 10 mΩ
Insulation resistance	10'000 MΩ (after climatic tests)
Dielectric strength	700 V _{RMS}
Air and creepage distances	min. 0.3 mm
Capacitance	max. 1 pF
Self inductance	2 nH max.

3. Ordering Information

3.1 Dimensions, Order Code Numbers and Packaging Information

Contact Plating Code –PP-:	body	spring
-91-	SnPb	Gold 0.25 um
-93-	SnPb	Gold 0.75 um
-97-	SnPb	Flash gold

Code for number of contacts –NNN- = total number of contacts

Code for wafer size –XX-: available for 14 and from 17 to 22

Code for contact arrangement and window size –YYY-: see Preci-Dip catalog

3.1.1 PGA socket PN 514-PP-NNN-XX-YYY154

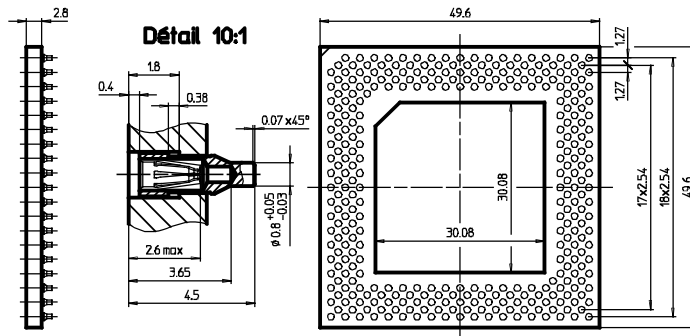

3.3 Availability

Now

Press-fit Mount Sockets for Interstitial Pin Grid Arrays Series 546-...147

1. Description and general features

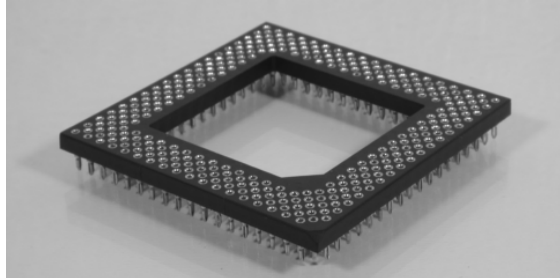

1.1 General description

Press-fit mount interstitial PGA sockets come with solderless press-fit terminations. This product line is based on the standard press-fit PGA sockets.

The press-fit terminations are a modified version of the «eye of the needle» technology, but adapted to PCB plated through holes with 0.7 mm diameter after metallisation.

1.2 Advantages

With only 0.85 mm drill dia. the space available for the conductive paths passing between contacts increases by 30% which greatly facilitates the PCB layout.

2. Technical Specifications

2.1 Environmental

Operating temperature	-55 ... + 125°C
Climatic Category (IEC)	55 / 125 / 21
Solderability	NA
Resistance to soldering heat	NA

2.2 Materials

Contact body	Machined bronze, plating 5 µm SnPb over 2.5 µm Ni
Contact spring	BeCu, gold plated (0.1, 0.25 or 0.75 µm) over Ni
Insulator	Glass fibre reinforced high temperature polyester PCT, self-extinguishing UL94V-0, colour black

Assembly of this new PGA is as easy as with the other press-fit versions and the tooling requirements are quite simple: a tool head of the flat rock type, and a support plate with the same hole configuration as the PCB.

Solderless press-fit technology eliminates the second soldering process normally necessary on PCBs with mixed technology which means that thermal stress on the components is cut to half.

Press-fit connections have excellent long term stability and are recommended for use under difficult environmental conditions.

1.3 Applications

Most benefits when used in SMD electronic assemblies and sub-assemblies where components in PGA packages cannot be replaced.

Covers all of the currently used interstitial PGA configurations, particularly those of the Pentium microprocessor family and the most common ASICs

1.4 Optional versions

Sockets with press-fit terminations for PCB holes of 0.9 +0.07/-0.05 mm diameter are available on request.

2.3 Mechanical Characteristics

Insertion force (initial)	0.6 N max. / 0.35 N typical, with polished steel gauge Ø 0.46 mm
Withdrawal force (initial)	0.15 N min / 0.2 N typical with polished steel gauge Ø 0.46 mm
Contact spring (clip) retention	40 N minimum
Mechanical life	100 cycles

2.4 Electrical Characteristics

Operating voltage	100 V _{RMS} / 150 V _{DC}
Continuous operating current	max. 1 A per terminal
Contact resistance	max. 10 mΩ
Insulation resistance	10'000 MΩ (after climatic tests)
Dielectric strength	700 V _{RMS}
Air and creepage distances	min. 0.3 mm
Capacitance	max. 1 pF

3. Ordering Information

3.1 Dimensions, Order Code Numbers and Packaging Information

Contact Plating Code –PP-:	body	spring
-91-	SnPb	Gold 0.25 µm
-93-	SnPb	Gold 0.75 µm
-97-	SnPb	Flash gold

Code for number of contacts –NNN- = total number of contacts

Code for wafer size –XX-: available for 14 and from 17 to 22

Code for contact arrangement and window size –YYY-: see Preci-Dip catalog

3.1.1 PGA socket PN 546-PP-NNN-XX-YYY147

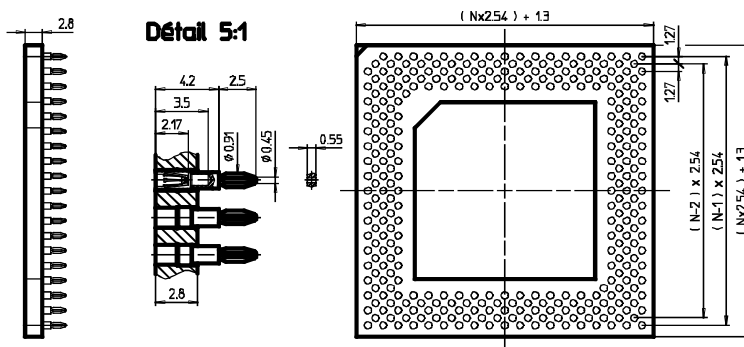

Press-fit characteristics

(PCB and plated trough-hole specification)

PCB material: Epoxy-glass laminate FR4 or equivalent

Board thickness 1.2 – 2.5 mm

Drill diameter 0.85 +/- 0.025 mm

Hole diameter 0.7 + 0.07 / - 0.05 mm after metallisation

Hole metallisation 5 µm min. SnPb over 25 µm Cu

Push-in force 50 N average with 0.7 mm diameter hole; 80 N max. with min. diameter hole

Push-out force 25 N average with 0.7 mm diameter hole; 10 N min. with max diameter hole

3.2 Availability

Now

Socket and adapter for 1.27 mm Ball Grid Array Series 514, 550 and 558

1. Description and general features

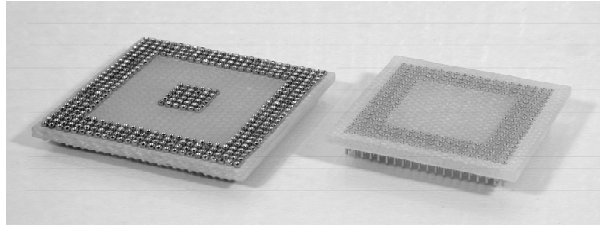

1.1 General description

The BGA adapter is a two part socket design for applications where direct soldering of the device cannot be accepted. The two components are:

- a SMD socket with floating contacts with the same footprint as the BGA device.
- an adapter with solder pads for the balls on the top side and pins on the bottom side.

The BGA is soldered on the adapter and then can be plugged into the sockets attached to the PCB.

For interconnect applications, the SMD PCB adapter is soldered to the daughter board, making it pluggable into the socket soldered to the mother board

1.2 Advantages

The best way to make BGA pluggable on PCB without layout design change.

The socket and PCB adapter provide a high density and low profile board interconnect system.

1.3 Applications

For testing, debugging and pre-productions runs of boards with BGA devices, and for PCB interconnection.

1.4 Optional versions

BGA socket and adapter with 1.50 mm grid.

PCB adapter with through hole terminations and 1.27 mm grid Series 558-...-101.

2. Technical Specifications

2.1 Environmental

Operating temperature	-55 ... + 125°C
Climatic Category (IEC)	55 / 125 / 21
Solderability	235°C, 10s
Resistance to soldering heat	280°C, 10s

2.2 Materials

Socket contact body	Machined brass, plating 5 µm SnPb over 2.5 µm Ni
Contact spring	BeCu, gold plated gold (0.25 or 0.75 µm) over Ni
Adapter pin	Machined brass, plating 0.25 µm gold over 2.5 µm Ni
Insulator	Glass-epoxy laminate FR4, self-extinguishing UL94V-0

2.3 Mechanical Characteristics

Insertion force (initial)	0.3 N max. / 0.2 N typical, with polished steel gauge Ø 0.43 mm
Withdrawal force (initial)	0.07 N min / 0.1 N typical with polished steel gauge Ø 0.43 mm
Contact spring (clip) retention	20 N minimum
Mechanical life	100 cycles
Coplanarity	0.1 mm

2.4 Electrical Characteristics

Operating voltage	50 V _{RMS} / 60 V _{DC}
Cont. operating current	max. 1 A per terminal
Contact resistance	max. 10 mΩ
Insulation resistance	10'000 MΩ (after climatic tests)
Dielectric strength	500 V _{RMS}
Air and creepage distances	min. 0.17 mm
Capacitance	max. 1 pF
Self inductance	2 nH max.

3. Ordering Information

3.1 Dimensions, Order Code Numbers and Packaging Information

Code for number of contacts –NNN- = total number of contacts
 Code for wafer size –XX-: available from 16 to 35
 Code for contact arrangement –YYY-: please consult

3.1.1 BGA socket PN 514-PP-NNNMXX-YYY148

Contact Plating Code –PP-:

	body	spring
-91-	SnPb	Gold 0.25 um
-93-	SnPb	Gold 0.75 um

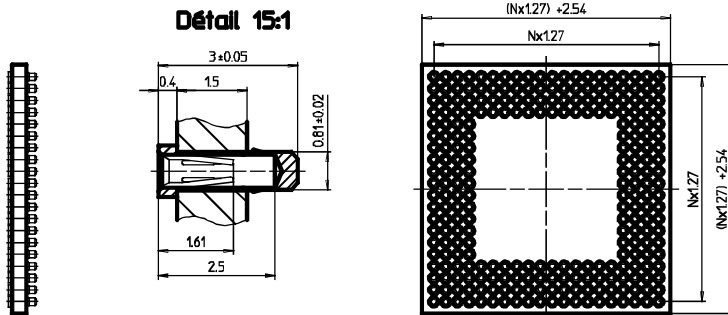

3.1.2 BGA adapter PN 550-PP-NNNMXX-YYY166

Contact Plating Code –PP-:

-10-	pin	Gold 0.25 um
------	------------	--------------

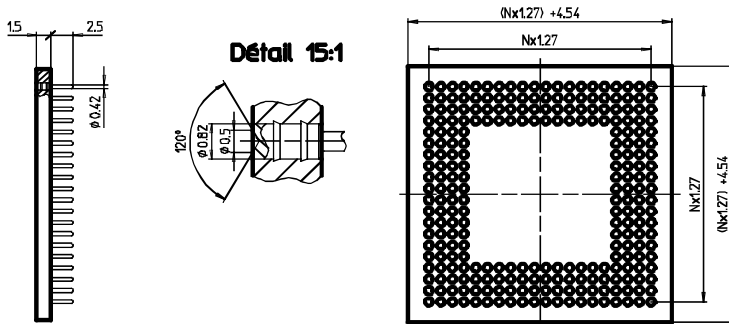

3.1.3 PCB adapter PN 558-PP-NNNMXX-YYY104

Contact plating code –PP-:

-10-	pin	Gold 0.25 um
------	------------	--------------

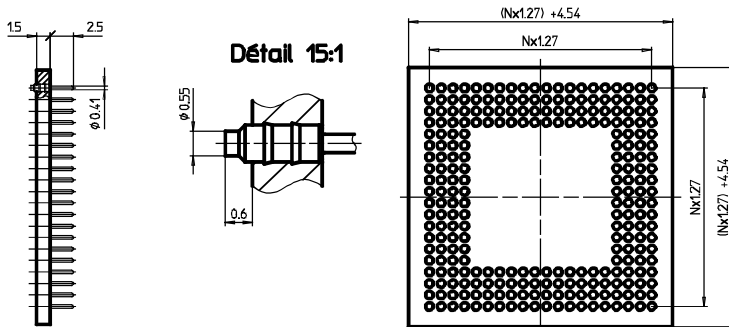

3.2 Availability

Now

Preci-Dip Durtal SA

CH-2800 Delémont / Switzerland
 phone +41 (32) 421 04 00 - fax +41 (32) 421 04 01
 mail:sales@precidip.com – www.precidip.com

Low Profile Spring Loaded Contact

1. Description and general features

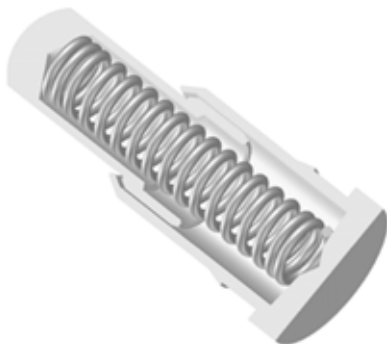

1.1 General description

Miniature, low profile, spring loaded SMD contact for applications demanding high current capacity, low electrical contact resistance and high cycle count.

Contact height available from 3.50 to 7.5 mm at initial position.

1.2 Advantages

Screw-machined pogo contact design optimised for low electrical contact resistance and high current capacity.
SMD contact with min. PCB space requirements.
Long working stroke (1.4 mm) despite of low profile.

1.3 Applications

Best solution for battery or battery loader connector for:

- mobile telephone and radio
- portable data processing and data acquisition equipment
- medical equipment
- test and measurement equipment
-

1.4 Optional versions

Currently none

2. Technical Specifications

2.1 Environmental

Operating temperature	-55 ... + 85°C
Climatic Category (IEC)	55 / 85 / 21
Solderability	235°C, 5s
Resistance to soldering heat	280°C, 10s

2.2 Materials

Contact piston	Machined brass, plating 0.5 µm Au over 2.5 µm Ni
Contact termination	Machined brass, plating 0.5 µm Au over 2.5 µm Ni
Spring	Music wire, plating Flash Au

2.3 Mechanical Characteristics

Total working travel	1.4 mm 1.15 mm for initial height 4.5 mm
Spring force (initial)	0.25 N
Spring force (at nominal position)	0.60 N at 0.7 mm stroke
Mechanical life	min. 40'000 cycles

2.4 Electrical Characteristics

Operating voltage	100 V _{RMS} / 150 V _{DC}
Operating current (per terminal)	max. 2 A continuous max. 3 A peak
Contact resistance	max. 20 mΩ

3. Ordering Information

3.1 Dimensions, Order Code Numbers and Packaging Information

Contact Plating Code: only available in the above given combination as standard

Packaging: Standard packaging: in box

3.1.1 Low profile SMD spring loaded Contact PN 900xx-AS

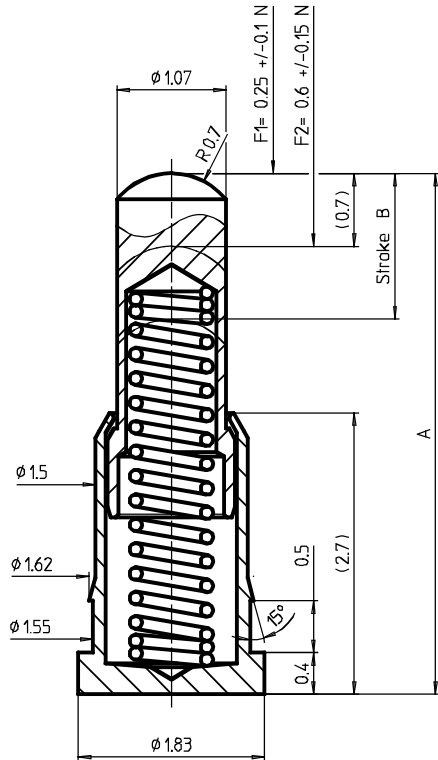

Initial height A [mm]	Stroke B [mm]	Part Number
3.50	1.00	90041-AS
4.25	1.40	90022-AS
4.5	1.40	90023-AS
5	1.40	90024-AS
5.5	1.40	90025-AS
6	1.40	90026-AS
6.5	1.40	90027-AS
7	1.40	90028-AS
7.5	1.40	90029-AS

3.2 Availability

Now

Spring Loaded Contact

1. Description and general features



1.1 General description

Miniature spring loaded contact with minimum diameter for applications demanding high current capacity, low electrical contact resistance and high cycle count.

Outside diameter smaller than 1 mm allowing contact arrangement on pitch as small as 1.25 mm for multiway connector.

1.2 Advantages

Screw-machined pogo contact design with internal sliding contact spring, optimised for low electrical contact resistance and high current capacity.

Contact termination PCB solder pin and solder cup for wire attachment.

Long working stroke: 1.4 mm.

1.3 Applications

Best solution for miniature high cycle count connectors in mobile and portable applications:

- mobile telephone and radio
- portable data processing and data acquisition equipment
- medical equipment
- test and measurement equipment
-

1.4 Optional versions

Currently none

2. Technical Specifications

2.1 Environmental

Operating temperature	-55 ... + 85°C
Climatic Category (IEC)	55 / 85 / 21
Solderability	235°C, 5s
Resistance to soldering heat	280°C, 10s

2.2 Materials

Contact piston	Machined brass, plating 0.5 µm Au over 2.5 µm Ni
Contact termination	Machined brass, plating 5 µm SnPb over 2.5 µm Ni
Spring	Stainless steel

2.3 Mechanical Characteristics

Total working travel	1.4 mm
Spring force (initial)	0.25 N
Spring force (at nominal position)	min. 0.80 N at 1 mm stroke
Mechanical life	min. 40'000 cycles

2.4 Electrical Characteristics

Operating voltage	100 V _{RMS} / 150 V _{DC}
Operating current (per terminal)	max. 1 A continuous max. 2 A peak
Contact resistance	max. 20 mΩ

3. Ordering Information

3.1 Dimensions, Order Code Numbers and Packaging Information

Contact Plating Code: only available in the above given combination as standard

Packaging: Standard packaging: box

3.1.1 Spring loaded Contact, ultra thin with straight solder pin termination PN 90014-AS

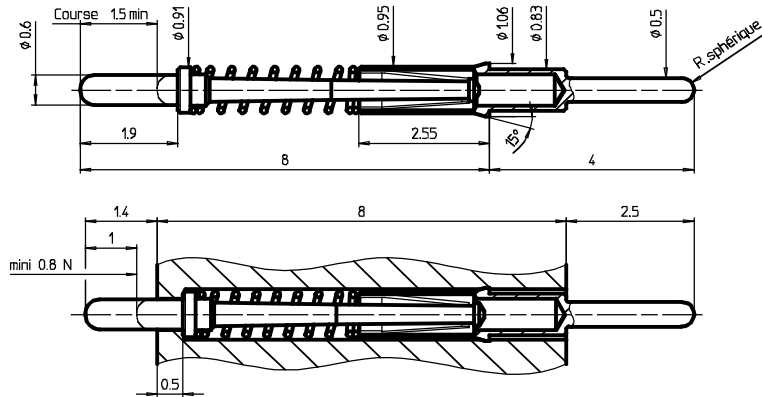

Main dimensions

Recommendation for contact cavity

3.1.2 Spring loaded Contact, ultra thin with solder cup termination PN 90049-AS

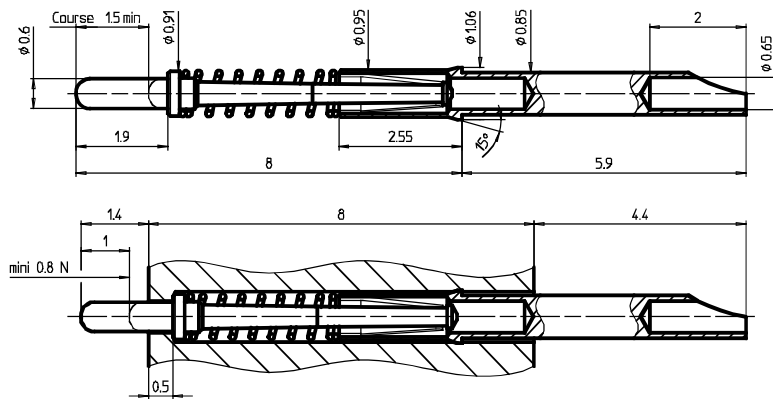

Main dimensions

Recommendation for contact cavity

3.2 Availability

Now

Modular Low Profile Spring Loaded Connector Series 811 and 813

1. Description and general features

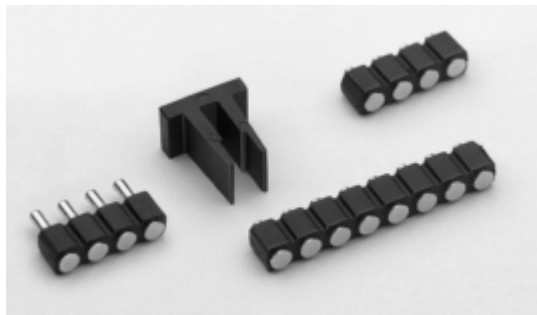

1.1 General description

Miniature spring loaded connector for applications demanding high current capacity, low electrical contact resistance and high cycle count.

Protected pogo contacts with high mechanical strength.

Modular systems with a contact pitch of 2.54 mm, with max. 10 contacts on one row or max. 20 contacts on a double row arrangement.

Connector height available from 4.5 to 7.5 mm at initial position.

Available with Tape & Reel packaging and plastic cap for automatic assembly with vacuum nozzle.

1.2 Advantages

Screw-machined pogo contact design optimised for low electrical contact resistance and high current capacity.

SMD connector with min. PCB space requirements.

Long working stroke (1.4 mm) despite of low profile.

1.3 Applications

The modular design makes these connectors the ideal solution for low to medium volume applications.

Best solution for battery or battery loader connector for:

- mobile telephone and radio
- portable data processing and data acquisition equipment
- medical equipment
- test and measurement equipment

1.4 Optional versions

Currently none

2. Technical Specifications

2.1 Environmental

Operating temperature	-55 ... + 85°C
Climatic Category (IEC)	55 / 85 / 21
Solderability	235°C, 5s
Resistance to soldering heat	280°C, 10s

2.3 Mechanical Characteristics

Total working travel	1.4 mm 1.15 mm for initial height 4.5 mm
Spring force (initial)	0.25 N
Spring force (at nominal position)	0.60 N at 0.7 mm stroke
Coplanarity SMD terminations	0.1 mm
Mechanical life	min. 40'000 cycles

2.2 Materials

Contact piston	Machined brass, plating 0.5 µm Au over 2.5 µm Ni
Contact termination	Machined brass, plating 0.5 µm Au over 2.5 µm Ni
Spring	Music wire, plating Flash Au
Insulator	Glass fibre reinforced high temperature polyester PCT, self-extinguishing UL94V-0, colour black

2.4 Electrical Characteristics

Operating voltage	100 V _{RMS} / 150 V _{DC}
Operating current (per terminal)	max. 2 A continuous max. 3 A peak
Contact resistance	max. 20 mΩ
Insulation resistance	10'000 MΩ (after climatic tests)
Dielectric strength	700 V _{RMS}
Air and creepage distances	min. 0.7 mm
Capacitance	max. 1 pF

3. Ordering Information

3.1 Dimensions, Order Code Numbers and Packaging Information

Contact Plating Code: only available in the above given combination as standard

Code for number of contacts: -0NN- (example for an 8 poles connector: -008-)

Packaging: **Standard packaging:** in box: replace xxx by suffix 101 to part number
Tape & Reel packaging: with plastic cap for automatic assembly with vacuum nozzle: replace xxx by suffix 191 to part number. Available number of pins see below. Other number of pins on request (min. quantity 10'000pcs)

3.1.1 Single row SMD mount Connector 811-SS-0NN-30-00xxx

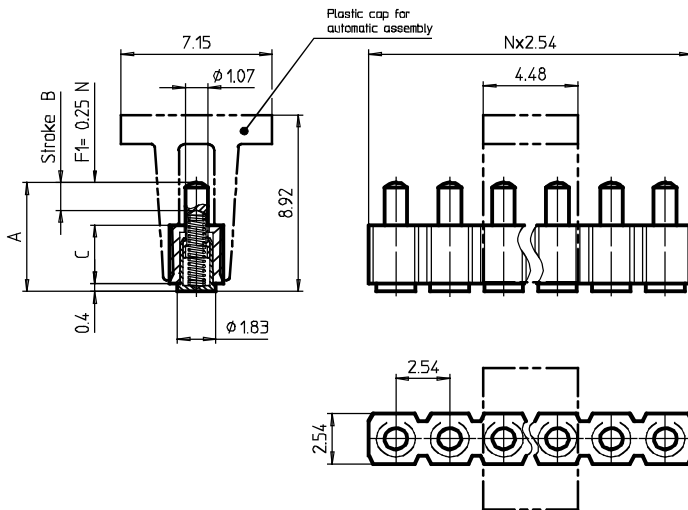

Available Number of Pins: 2 to 10

Initial height A [mm]	Plastic Body C [mm]	Part Number
4.5	2.95	811-SS-0NN-30-001xxx
5	2.95	811-SS-0NN-30-002xxx
5.5	2.95	811-SS-0NN-30-003xxx
6	4	811-SS-0NN-30-004xxx
6.5	4	811-SS-0NN-30-005xxx
7	4	811-SS-0NN-30-006xxx
7.5	4	811-SS-0NN-30-007xxx

T&R Packaging:	-001191	-002191 to -007191
Avail. Number of pins	2 to 4	2 to 10
Tape width	16 mm	44 mm
Pitch on tape	8 mm	12 mm
Reel diameter	330 mm	330 mm
Number of pcs per reel:	1300	600
Number of pcs per box:	7500	2400

3.1.2 Double row SMD mount Connector 813-SS-0NN-30-00xxxx

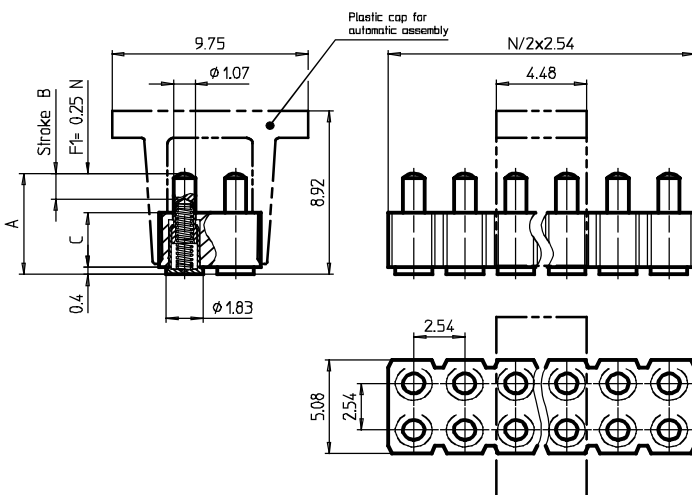

Available Number of Pins: 4 to 20

Initial height A [mm]	Plastic Body C [mm]	Part Number
4.5	2.95	813-SS-0NN-30-001xxx
5	2.95	813-SS-0NN-30-002xxx
5.5	2.95	813-SS-0NN-30-003xxx
6	4	813-SS-0NN-30-004xxx
6.5	4	813-SS-0NN-30-005xxx
7	4	813-SS-0NN-30-006xxx
7.5	4	813-SS-0NN-30-007xxx

T&R Packaging:	-001191 to -007191
Avail. Number of pins	4 to 16
Tape width	32 mm
Pitch on tape	12 mm
Reel diameter	330 mm
Number of pcs per reel:	600
Number of pcs per box:	1800

3.2 Availability

Now

Chip Card Spring Loaded Connector 8PM-SS-0006-01-913

1. Description and general features

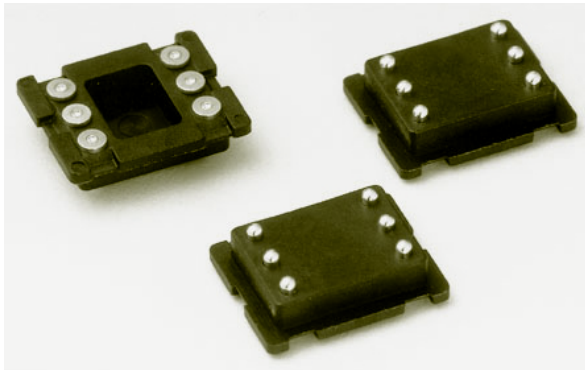

1.1 General description

Miniature connector for standard or miniature sized chip cards with contacting pads according to ISO 7816
Protected, machined pogo contacts with high life and low electrical contact resistance.

Basic model for SMD mount without cover or locking device for free integration into the application.
Available with Tape & Reel packaging for automatic assembly.

1.2 Advantages

The connector, equipped with screw-machined pogo contacts, is covering a minimum PCB area, only 12.2 x 9.7 mm².

The very low profile with a typical working height of only 3.75 mm is combined with an improved working stroke of 1 mm.

1.3 Applications

Particularly well adapted for all kind of mobile equipment where space is a critical factor.

1.4 Optional versions

Currently none.

2. Technical Specifications

2.1 Environmental

Operating temperature	-55 ... + 85°C
Climatic Category (IEC)	55 / 85 / 21
Solderability	235°C, 5s
Resistance to soldering heat	280°C, 10s

2.2 Materials

Contact piston	Machined brass, plating 0.4 µm Au over 2.5 µm Ni
Contact termination	Machined brass, plating 0.4 µm Au over 2.5 µm Ni
Spring	Music wire, plating Flash Au
Insulator	Glass fibre reinforced high temperature polyester PCT, self-extinguishing UL94V-0, colour black

2.3 Mechanical Characteristics

Total working travel	1 mm
Spring force (initial)	0.25 N
Spring force (at nominal position)	0.60 N at 0.7 mm stroke
Coplanarity SMD terminations	0.1 mm
Mechanical life	min. 40'000 cycles

2.4 Electrical Characteristics

Operating voltage	100 V _{RMS} / 150 V _{DC}
Operating current (per terminal)	max. 2 A continuous max. 3 A peak
Contact resistance	max. 20 mΩ
Insulation resistance	10'000 MΩ (after climatic tests)
Dielectric strength	500 V _{RMS}
Air and creepage distances	min. 0.7 mm
Capacitance	max. 1 pF

3. Ordering Information

3.1 Dimensions, Order Number Code and Packaging Information

PN 8PM-SS-0006-01-913

Contact plating code: only available in the above given combination as standard

Packaging:	Tape & Reel:	Tape width	24 mm
		Pitch on tape	12 mm
		Reel diameter	330 mm
		Number of pcs per reel	1300
		Number of pcs per box	3900

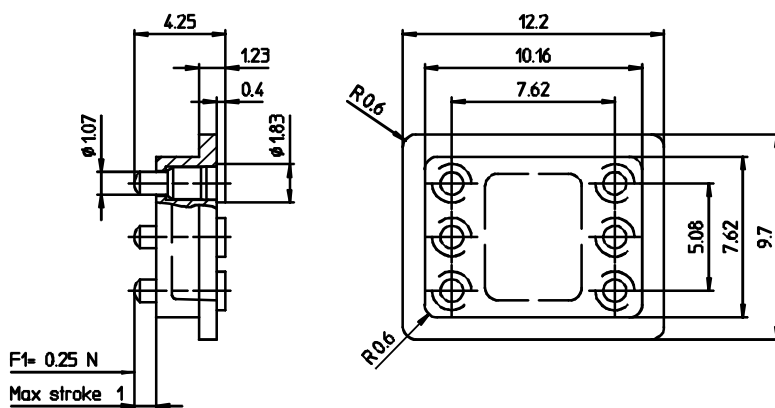

3.2 Availability

Now

X-ON Electronics

Largest Supplier of Electrical and Electronic Components

Click to view similar products for [Headers & Wire Housings](#) category:

Click to view products by [Precidip](#) manufacturer:

Other Similar products are found below :

[95000-104TRLF](#) [10135584-644402LF](#) [DF62W-EP2022PCA](#) [95000-106TRLF](#) [DF62W-2022SCA](#) [DF62W-EP2022PC](#) [2203348](#) [DF62W-2022SC](#) [1084018](#) [1029039](#) [1084017](#) [802-10-012-10-002000](#) [1112640](#) [1112639](#) [891-007-9SS-BST1T](#) [000-34000](#) [0008550134](#) [0009482033](#) [0009507031](#) [57102-F02-18ULF](#) [57102-S06-03LF](#) [57202-S52-04LF](#) [PCN6-15S-2.5E](#) [0039019024](#) [58102-G61-06LF](#) [582553-1](#) [0009485154](#) [0009508121](#) [0022285053](#) [0050291907](#) [018731A](#) [LY20-4P-DT1-P1E-BR](#) [02.125.8002.8](#) [60101931](#) [60598-1 \(Cut Strip\)](#) [M1625-3R/100](#) [61062-3](#) [61082-181009](#) [CSU011177004](#) [636-1427](#) [638009-1](#) [641938-9](#) [641991-4](#) [644168-1](#) [644827-2](#) [647662-1](#) [65039-019ELF](#) [65692-001LF](#) [65781-018](#) [65781-047](#)