

Large Setting Dial and Moving Pointers Ideal for Easy Operation and Monitoring

- Incorporating an easy-to-see large setting dial with moving pointers.
- Wide time-setting range of 0.2 s to 60 h (available through three time-range model types)
- Wide AC power supply range (100 to 240 VAC)
- IP65 watertight and dust-tight front panel.
- Approved by UL and CSA.
- Conforms to IEC61812-1 (VDE0435/P2021)
- Conforms to IEC60664-1 (VDE0110) 4KV/2
- Conforms to EMC standards.
- Six-language instruction manual provided.
- Programmable contact enables the building of a self-holding relay circuit as well as built-in instantaneous contact. (-NS)
- Memory retention (-NSR)
- Finger protection terminal block
- High immunity to inverter noise
- Enables easy sequence checks through instantaneous outputs for a zero set value at any time range



Ordering Information

Rated supply voltage	Resetting system	Control output	Time range		
			0.5 s to 30 h (30 s, 3 min, 30 min, 3 h, 30 h)	1 s to 60 h (60 s, 6 min, 60 min, 6 h, 60 h)	0.2 s to 12 h (12 s, 120 s 12 min, 120 min, 12 h)
100 to 240 VAC	Self-resetting	DPDT contact output (Time-limit output SPDT and switchable SPDT (time-limit ↔ instantaneous))	H3AM-NS-A	H3AM-NS-B	H3AM-NS-C
	Electric resetting	DPDT contact output (Time-limit output SPDT and instantaneous output SPDT)	H3AM-NSR-A	H3AM-NSR-B	H3AM-NSR-C

Model Number Legend

H3AM - NS - -
 1 2 3

1. Resetting System

None: Self-resetting
R: Electric resetting

2. Time Range

A: 0.5 s to 30 h
B: 1 s to 60 h
C: 0.2 s to 12 h

3. Accessory

None: Without accessory
300: Waterproof Packing
(Y92S-35) provided

Accessory

Item	Model
Waterproof Packing	Y92S-35

Specifications

■ General

Operating mode	ON-delay
Screw tightening torque	0.98 N • m (10 kgf) max.
Input type	Voltage input
Output type	Relay: DPDT
Mounting method	Flush/Panel mounting, no restriction on mounting angle.
Approved standards	UL 508, CSA C22.2 No. 14 Conforms to EN61812-1 (VDE0435/P2021), IEC60664-1 (VDE01104 kV/2, VDE0106/P100) Conforms to EN50081-2 and EN50082-2

■ Time Ranges

Model	Full scale on dial	Set time unit					
		s	10 s	min	10 min	h (hour)	10 h (hour)
H3AM-□□□-A	3	---	0.5 to 30 s	0.05 to 3 min	0.5 to 30 min	0.05 to 3 h	0.5 to 30 h
H3AM-□□□-B	6	---	1 to 60 s	0.1 to 6 min	1 to 60 min	0.1 to 6 h	1 to 60 h
H3AM-□□□-C	12	0.2 to 12 s	2 to 120 s	0.2 to 12 min	2 to 120 min	0.2 to 12 h	---

Note: Instantaneous output is obtained by turning the time setting knob below "0" until the time setting knob stops.

■ Ratings

Rated supply voltage	100 to 240 VAC (50/60 Hz)
Operating voltage range	85% to 110% of rated supply voltage
Power reset (-NS)	Minimum power-opening time: 0.5 s
Reset input time (-NSR)	Minimum input time: 0.5 s
Reset voltage range (-NSR)	H level: 85 to 264 VAC L level: 0 to 10 VAC
Power consumption	Approx. 9 VA (Approx. 5 W)
Control output	Contact output: 5 A at 250 VAC, resistive load ($\cos\phi = 1$)
Ambient temperature	Operating: -10°C to 55°C (with no icing) Storage: -25°C to 65°C (with no icing)
Ambient humidity	Operating: 35% to 85%

■ Characteristics

Accuracy of operating time	±0.7% FS max.
Setting error	±2% FS max.
Reset time	Power reset: 0.5 s max. Reset input time: 0.5 s max.
Influence of voltage	±1% FS max.
Influence of temperature	±2% FS max.
Insulation resistance	100 MΩ max. (at 500 VDC)
Dielectric strength	2,000 VAC (50/60 Hz) for 1 min between exposed non-current-carrying metal parts and current-carrying metal parts 2,000 VAC (50/60 Hz) for 1 min between the operating circuit and control output terminals 1,000 VAC (50/60 Hz) for 1 min between the operating power supply circuit and reset input circuit (H3AM-NSR only) 1,000 VAC (50/60 Hz) for 1 min between contacts not located next to each other 2,000 VAC (50/60 Hz) for 1 min between contacts of opposite poles
Impulse withstand voltage	3 kV between power terminals 4.5 kV between exposed non-current-carrying metal parts and current-carrying metal parts
Noise immunity	±1.5 kV (between power terminals) square-wave noise by a noise simulator (pulse width: 100 ns/1 μs, 1-ns rise)
Static immunity	Malfunction: 8 kV Destruction: 15 kV
Vibration resistance	Destruction: 10 to 55 Hz, 0.75-mm single amplitude Malfunction: 10 to 55 Hz, 0.5-mm single amplitude
Shock resistance	Destruction: 300 m/s ² (approx. 30G) Malfunction: 150 m/s ² (approx. 15G) (100 m/s ² (approx. 10G) in the front/back direction)
Life expectancy	Mechanical: 5,000,000 times min. (under no load at 1,800 times/h) Electrical: 100,000 times min. (5-A at 250 VAC, resistive load at 1,800 times/h)
EMC	(EMI): 50081-2 Emission Enclosure: EN55022 class A Emission AC Mains: EN55022 class A (EMS): 50082-2 Immunity ESD: EN61000-4-2: 4 kV contact discharge (level 2) 8 kV air discharge (level 3) Immunity RF-interference: ENV50140: 10 V/m (80 MHz to 1 GHz) (level 3) ENV50204: 10 V/m (900 MHz±5 MHz) (level 3) Immunity Power Frequency Magnetic Fields: EN61000-4-8: 30 A/m (50 Hz) (level 4) Immunity Conducted Disturbance: ENV50141: 10 V (0.15 to 80 MHz) (level 3) Immunity Burst: EN61000-4-4: 2 kV power-line (level 3) 2 kV I/O signal-line (level 4) Immunity Surge: EN61000-4-5: 1 kV line to line 2 kV line to ground (level 3)
Enclosure rating	IP65 (front panel only) (see note) IP20 (terminal section)
Weight	Approx. 350 g

Note: A separately sold waterproof packing (Y92S-35) is necessary to ensure IP65 waterproofing between the Timer and installation panel. The H3AM-NS□-□-300 model with waterproof packing is available.

Nomenclature

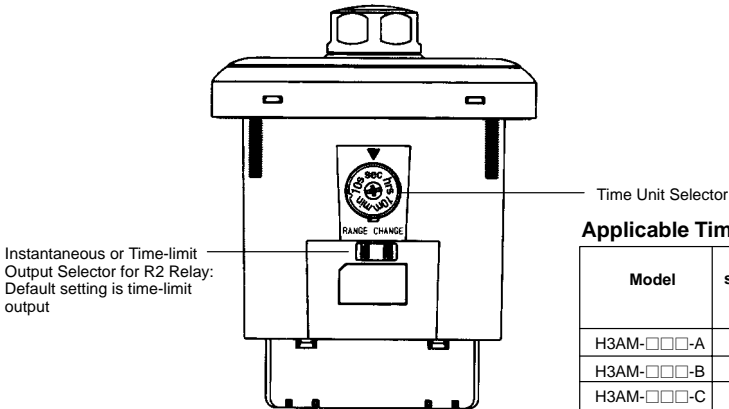
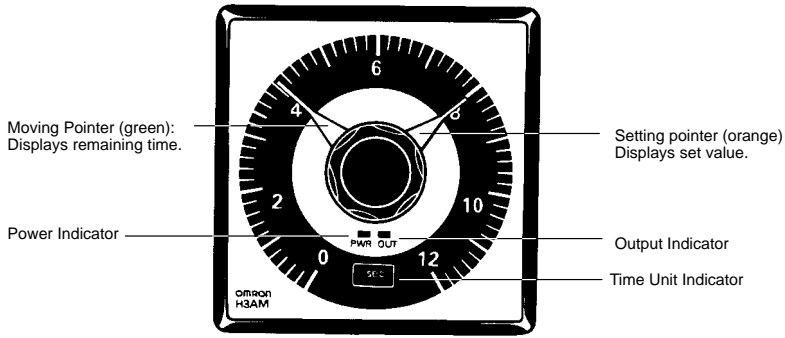

(Illustrated Model: H3AM-□□□-C)

Applicable Time Unit

Model	Full scale on dial	Applicable time unit					
		s	10 s	min	10 min	h	10 h
H3AM-□□□-A	3	No	Yes	Yes	Yes	Yes	Yes
H3AM-□□□-B	6	No	Yes	Yes	Yes	Yes	Yes
H3AM-□□□-C	12	Yes	Yes	Yes	Yes	Yes	No

Operation

■ Timing Charts

H3AM-NS

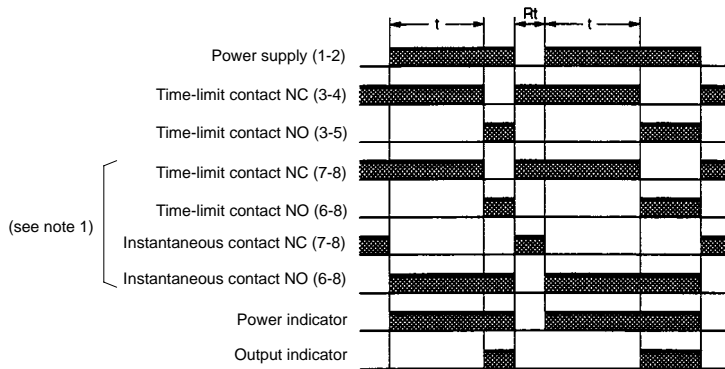

- Note:**
1. The R2 contacts (7-8 and 6-8) are programmable and can be set to either instantaneous or time-limit contact.
 2. "Rt" indicates reset time and "t" indicates set time.

H3AM-NSR

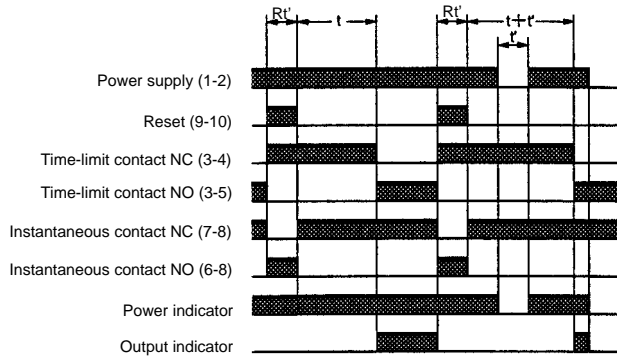

- Note:** "Rt'" indicates reset input time and "t" indicates set time.

Dimensions

Note: All units are in millimeters unless otherwise indicated.

H3AM (Flush Mounting)

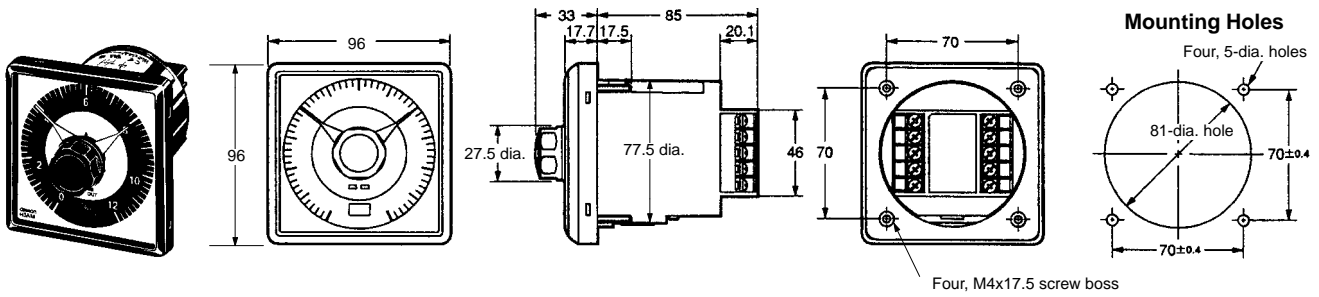

Note: Tightening torque for panel mounting is as follows:
 $300 \text{ m N} \cdot \text{m} \pm 50 \text{ m N} \cdot \text{m}$ ($3 \text{ kgf} \cdot \text{cm} \pm 0.5 \text{ kgf} \cdot \text{cm}$)

■ Waterproof Packing (Sold Separately)

- Prevents water ingress between the Timer and panel.

Y92S-35

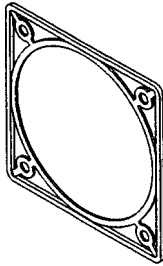

Installation

■ Internal Connections and Terminal Arrangement

H3AM-NS

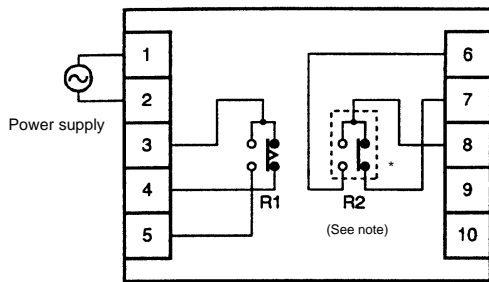

H3AM-NSR

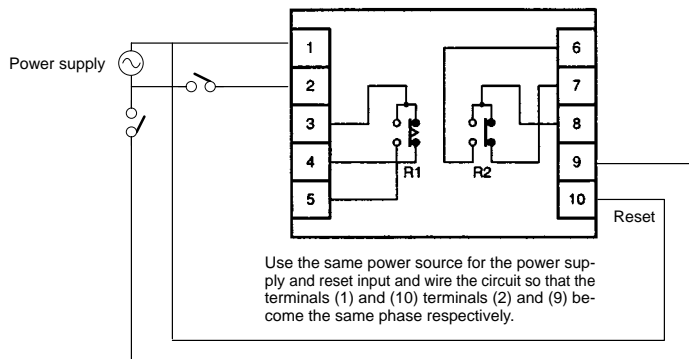

Note: The R2 relay can be set to either instantaneous or time-limit contact using the switch located on the bottom of the Timer (H3AM-NS models).

Precautions

Before Use

Before using the H3AM-NSR, apply voltage between terminals 9 and 10 to reset the operation.

When changing the setting time of the H3AM-NSR to a longer time value, be sure to apply voltage between terminals 9 and 10 during the change, otherwise the Timer may malfunction.

Correct Use

Setting Changes

Be sure to adjust the time unit selector and instantaneous or time-limit output selector for R2 relay only before the Timer is turned ON, otherwise the Timer may be damaged or malfunction.

Be sure to set the time only when Timer has stopped, otherwise the Timer may malfunction.

Power Supply

Use a switch or relay contact to impose supply voltage on the Timer at one time. If the supply voltage is imposed on the Timer gradually, the Timer may not reset or a time-up error may result.

Time Setting

Do not turn the time setting knob beyond the permissible range. If a precise time setting is required, check the operation of the Timer in trial operation before the Timer is put in actual operation.

Operating Environment

If the Timer is used in any place that may be affected by noise, be sure to separate the Timer, input device, and connecting wires from the noise source. The use of shielded wires for the input line is recommended.

The external surfaces of the Timer may be affected by organic solvents such as thinner, benzene, or a strong alkaline or strong acidic substance.

Do not use the Timer in a location where the Timer is exposed to corrosive gas or direct sunlight or where there is excessive dust.

Water Protection

When mounting the Timer on a panel, evenly tighten the Timer to a specified torque. If the Timer using waterproof packing is tightened to a torque other than the specified value, required waterproof properties will not be achieved.

Others

If the Timer is mounted on a control panel, dismount the Timer from the control panel or short-circuit the circuitry before carrying out a voltage withstand test between the electric circuitry and non current-carrying metal part of the machine, in order to prevent the internal circuitry of the Timer from damage.

The internal elements may be damaged if a voltage other than the rated supply voltage is applied.

Precautions for VDE Conformance

The H3AM as a built-in timer conforms to VDE0435/P2021 provided that the following conditions are satisfied:

The output section of the H3AM is provided only with basic isolation. To ensure reinforced isolation required by the VDE standards, provide supplementary basic isolation on the load side connected to the output.

The H3AM itself is designed according to the following:

- Overvoltage category III
- Pollution degree 2

On the above basis:

Operation parts on the front and bottom: Reinforced isolation

With clearance of 5.5 mm and creepage distance of 5.5 mm at 240 VAC

Output: Basic isolation

With clearance of 3.0 mm and creepage distance of 3.0 mm at 240 VAC

ALL DIMENSIONS SHOWN ARE IN MILLIMETERS.

To convert millimeters into inches, multiply by 0.03937. To convert grams into ounces, multiply by 0.03527.

Cat. No. L095-E1-1 **In the interest of product improvement, specifications are subject to change without notice.**

OMRON Corporation

Industrial Devices and Components Division
Supervisory Control Devices Division
28th Fl., Crystal Tower Bldg.
1-2-27, Shiromi, Chuo-ku,
Osaka 540-6028 Japan
Phone: (81)6-949-6014 Fax: (81)6-949-6069

Printed in Japan
0998-2M (0298) Ⓐ

X-ON Electronics

Largest Supplier of Electrical and Electronic Components

Click to view similar products for [omron](#) manufacturer:

Other Similar products are found below :

[G9ED-1-B-AQ-DC24](#) [E3X-SD11 2M](#) [S8VM-10024C](#) [R88A-CCW002P2](#) [S82Y-VM30D](#) [H3AM-NS-A AC100-240](#) [44532-2050](#) [G3NA-440B-2 DC5-24](#) [XF2J-0824-11A-R100](#) [G3NA-425B-2 DC5-24](#) [XF2J-0824-12A](#) [G8VA-1A4T-R01-DC12](#) [G8HE-1A7T-R-DC12](#) [XF2W-2415-1A](#) [XF2U-3015-3A](#) [G8V-RH-1A7T-R-DC12](#) [LY1D-2-5S-AC120](#) [CS1G-CPU43-E](#) [M22CAT1](#) [61F-GP-NT AC110](#) [M7E-01DGN2-B](#) [M7E-02DGN2](#) [M7E-08DRN2](#) [M7E-20DRN1](#) [M7E-HRN2](#) [M8PHWS](#) [D2HW-C233MR](#) [F03-02 SUS316](#) [F150LTC20](#) [F3SJ-A0245P30](#) [F3STGRNSMC21M1J8](#) [F3UVHM](#) [MG2-US-AC24](#) [MK2EP-UA-AC6V](#) [MK2PNIAC240](#) [MK310E-DC24](#) [MKS2XTIN-11 DC110](#) [MM4KPAC120NC](#) [MM4XPAC120](#) [G2Q-184P-V-DC5](#) [G2R-1114P-V-US-DC5](#) [G2R13SNDDC24](#) [G2RL-2A4-CF-DC48](#) [G2U-114P-US-DC12](#) [G2V-234P-US-DC48](#) [G3CA-8H-AC100/110/120](#) [G3PA-210B-US-DC24](#) [G3PE525B3NDC1224](#) [G3SD-Z01P-PD-US DC24](#) [G3TA-ODX02S DC24](#)