

Fiber Optic Receiver

OPF2418, OPF2418T, OPF2418TC



Features:

- Up to 194 Mbps operation
- 850nm wavelength
- ST[®] style port
- Wave solderable
- Wide temperature range

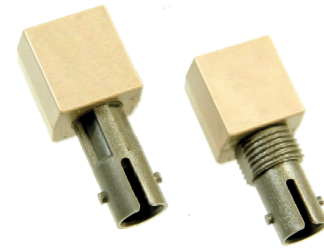

Description:

The OPF2418 family is a low cost solution for high speed fiber optic communications designs. The internal lensing of this receiver's design allows optimal response for fiber sizes of 100µm and below. The receiver is comprised of a high speed, low noise, photodiode coupled to a transimpedance amplifier (TIA). The photodiode/TIA combination produces an output voltage that is proportional to the input light amplitude. This hybrid approach solves many of the problems of high speed data link designs by placing the photodiode close to the TIA. The amplification of the TIA makes the output much less susceptible to EMI. The output of the OPF2418 is an analog, low impedance, emitter follower voltage source. Subsequent circuitry can be utilized to convert the analog voltage to ECL/TTL for digital data rates up to 155 Mbps. The OPF2418 is available with either standard or threaded panel mount ST[®] receptacles. The threaded version is also available in conductive plastic.

Applications:

- Industrial Ethernet equipment
- Copper-to-fiber media conversion
- Intra-system fiber optic links
- Video surveillance systems

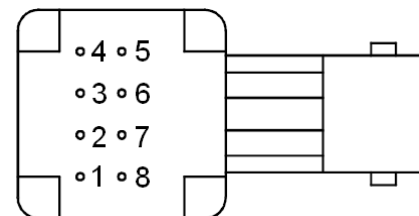
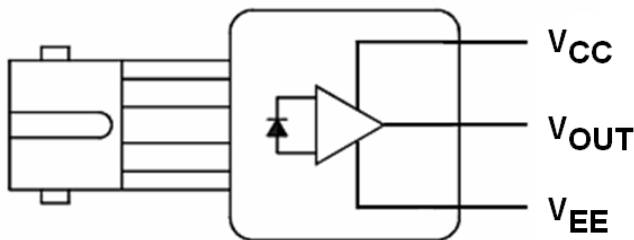

| PIN | FUNCTION |
|-----|------------------|
| 1 | Not Connected |
| 2 | V _{OUT} |
| 3 | V _{EE} |
| 4 | Not Connected |
| 5 | Not Connected |
| 6 | V _{CC} |
| 7 | V _{EE} |
| 8 | Not Connected |

"T" suffix = Threaded ST[®] package
 "TC" suffix = Threaded, conductive ST[®] package

Pins 3 & 7 are electrically connected to the header.
 Pins 1,4,5 & 8 are mechanically connected together.



RoHS



ESD Class 2

ST[®] is a registered trademark of AT&T.

General Note
 TT Electronics reserves the right to make changes in product specification without notice or liability. All information is subject to TT Electronics' own data and is considered accurate at time of going to print.

OPTEK Technology, Inc.
 1645 Wallace Drive, Carrollton, TX 75006 | Ph: +1 972 323 2200
www.optekinc.com | www.ttelectronics.com

Fiber Optic Receiver

OPF2418, OPF2418T, OPF2418TC



Mechanical Data

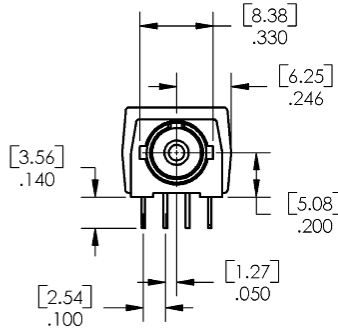
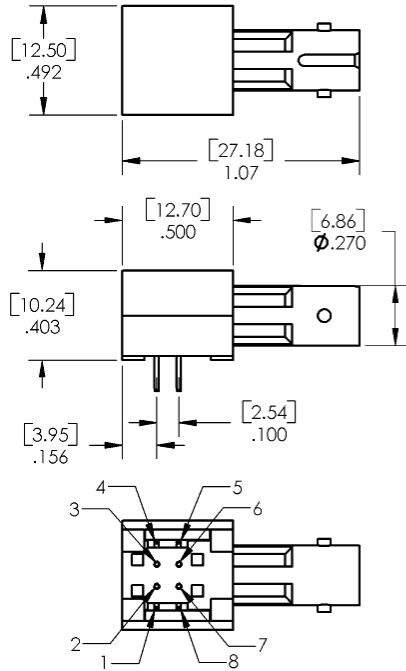

PINS 1, 4, 5, & 8 - .020 X .015
[0.51 X 0.38]
PINS 2, 3, 6, & 7 - Ø.018
[0.46]

OPF2418

OPF2418T OPF2418TC

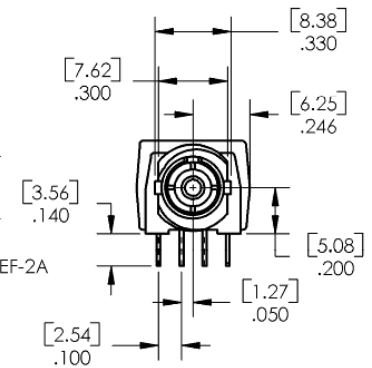
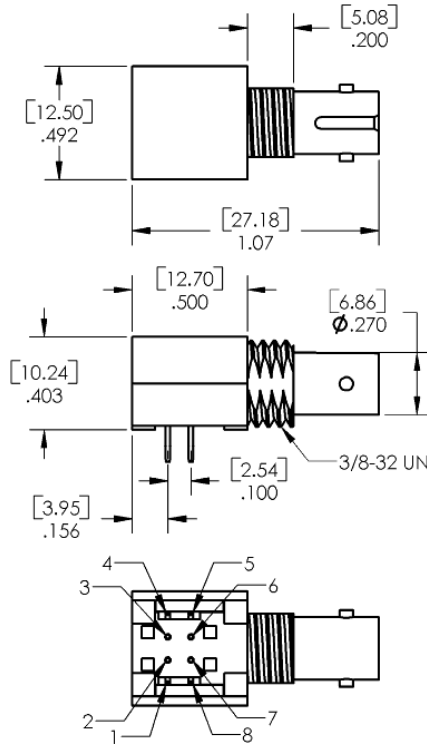

PINS 1, 4, 5, & 8 - .020 X .015
[0.51 X 0.38]
PINS 2, 3, 6, & 7 - Ø.018
[0.46]

DIMENSIONS ARE IN: [MILLIMETERS]
INCHES

General Note
TT Electronics reserves the right to make changes in product specification without notice or liability. All information is subject to TT Electronics' own data and is considered accurate at time of going to print.

OPTEK Technology, Inc.
1645 Wallace Drive, Carrollton, TX 75006 | Ph: +1 972 323 2200
www.optekinc.com | www.ttelectronics.com

Electrical Specifications

| Absolute Maximum Ratings ($T_A = 25^\circ\text{C}$ unless otherwise noted) | |
|---|------------------|
| Storage Temperature Range | -55° C to +85° C |
| Operating Temperature Range | -40° C to +85° C |
| Lead Soldering Temperature ⁽¹⁾ | 260° C |
| Supply Voltage | -0.5 V to 6.0 V |
| Output Current | 25 mA |
| Output Pin Voltage | -0.5 V |

| Electrical Characteristics ($T_A = 25^\circ\text{C}$ unless otherwise noted) | | | | | | |
|---|--|------|-------|-------|-------------------|--|
| SYMBOL | PARAMETER | MIN | TYP | MAX | UNITS | TEST CONDITIONS |
| R | Responsivity | 5.3 | 7.0 | 9.6 | mV/ μW | $\lambda_p = 850\text{ nm}$, $f = 50\text{ MHz}$ |
| | | 4.5 | | 11.5 | | $-40^\circ\text{C} \leq T_A \leq +85^\circ\text{C}$ |
| V_{NOISE} | RMS Output Noise Voltage | | 0.40 | 0.59 | mV | 75 MHz Bandwidth Filtered, $P_R = 0$ |
| | | | | 0.70 | | Unfiltered Bandwidth Filtered, $P_R = 0$ |
| P_N | RMS Equivalent Optical Noise Input Power | | 0.050 | 0.065 | μW | 100 MHz Bandwidth Filtered, $P_R = 0$ |
| P_R | Peak Received Optical Power | | | 175 | μW | $40^\circ\text{C} \leq T_A \leq +85^\circ\text{C}$ |
| | | | | 150 | μW | |
| V_{ODC} | DC Output Voltage | -4.2 | -3.1 | -2.4 | V | $P_R = 0$ |
| I_{EE} | Supply Current | | 9 | 15 | mA | $R_L = \infty$ |
| BW | Bandwidth | 155 | 200 | | MHz | -3dB electrical |
| t_r, t_f | Rise Time, Fall Time | | 2.0 | 2.6 | ns | $f = 50\text{ MHz}$, $P_R = 100\ \mu\text{W peak}$, $R_L = 511\ \Omega$, $C_{\text{LOAD}} = 5\text{ pF}$ |
| PWD | Pulse Width Distortion | | 0.4 | 2.5 | ns | $f = 50\text{ MHz}$, $P_R = 150\ \mu\text{W peak}$ |
| PSRR | Power Supply Rejection Ratio | | 20 | | dB | $f = 10\text{ MHz}$ |

Notes:

- Maximum of 5 seconds with soldering iron. Duration can be extended to 10 seconds when flow soldering. RMA flux is recommended.

Application Circuit

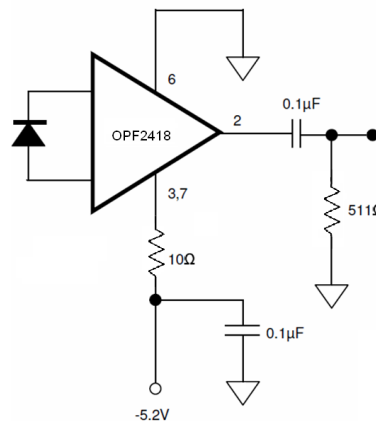

Note that the 10W resistor and bypass capacitor are critical.

General Note
TT Electronics reserves the right to make changes in product specification without notice or liability. All information is subject to TT Electronics' own data and is considered accurate at time of going to print.

X-ON Electronics

Largest Supplier of Electrical and Electronic Components

Click to view similar products for [Fiber Optic Transmitters, Receivers, Transceivers](#) *category:*

Click to view products by [TT Electronics](#) *manufacturer:*

Other Similar products are found below :

[FWLF-1521-7D-47](#) [FWLF-1521-7D-61](#) [HFBR-1532ETZ](#) [HFBR-2541ETZ](#) [HFBR-2602Z](#) [AFBR-0548Z](#) [AFBR-1639Z](#) [AFBR-1539Z](#) [AFBR-2634Z](#) [AFCT-5962ATLZ](#) [FTLX3813M354](#) [HFBR-2531ETZ](#) [STV.2413-574-00262](#) [TRPRG1VA1C000E2G](#) [TORX1952\(6M,F\)](#)
[TOTX1350\(F\)](#) [TOTX1350\(V,F\)](#) [FTLX3813M349](#) [HFBR-2542ETZ](#) [SCN-1428SC](#) [AFBR-POC406L](#) [HFBR-2506AFZ](#) [FTLX1871M3BNL](#)
[FWLF-1521-7D-49](#) [HFBR-1542ETZ](#) [FWLF-1519-7D-49](#) [HFBR-2532ETZ](#) [AFBR-1541CZ](#) [TORX1355\(V,F\)](#) [AFBR-1521CZ](#) [LTK-ST11MB](#)
[TORX1355\(F\)](#) [HFD8003-002/XBA](#) [HFD3020-500-ABA](#) [S6846](#) [SCN-2638SC](#) [FTL410QE4N](#) [SCN-1570SC](#) [SCN-1601SC](#) [SCN-1338SC](#)
[HFBR-1505CFZ](#) [AFBR-1528CZ](#) [AFBR-1531CZ](#) [HFD3081-108-XBA](#) [HFD8003-500-XBA](#) [SCN-1255SC](#) [SCN-1383SC](#) [1019682](#) [1019683](#)
[1019705](#)