

DATA SHEET

For a complete data sheet, please also download:

- The IC06 74HC/HCT/HCU/HCMOS Logic Family Specifications
- The IC06 74HC/HCT/HCU/HCMOS Logic Package Information
- The IC06 74HC/HCT/HCU/HCMOS Logic Package Outlines

74HC/HCT173

Quad D-type flip-flop; positive-edge trigger; 3-state

Product specification
File under Integrated Circuits, IC06

December 1990

Quad D-type flip-flop; positive-edge trigger; 3-state

74HC/HCT173

FEATURES

- Gated input enable for hold (do nothing) mode
- Gated output enable control
- Edge-triggered D-type register
- Asynchronous master reset
- Output capability: bus driver
- I_{CC} category: MSI

GENERAL DESCRIPTION

The 74HC/HCT173 are high-speed Si-gate CMOS devices and are pin compatible with low power Schottky TTL (LSTTL). They are specified in compliance with JEDEC standard no. 7A.

The 74HC/HCT173 are 4-bit parallel load registers with clock enable control, 3-state buffered outputs (Q₀ to Q₃) and master reset (MR).

When the two data enable inputs (\bar{E}_1 and \bar{E}_2) are LOW, the data on the D_n inputs is loaded into the register

synchronously with the LOW-to-HIGH clock (CP) transition. When one or both \bar{E}_n inputs are HIGH one set-up time prior to the LOW-to-HIGH clock transition, the register will retain the previous data. Data inputs and clock enable inputs are fully edge-triggered and must be stable only one set-up time prior to the LOW-to-HIGH clock transition.

The master reset input (MR) is an active HIGH asynchronous input. When MR is HIGH, all four flip-flops are reset (cleared) independently of any other input condition.

The 3-state output buffers are controlled by a 2-input NOR gate. When both output enable inputs (\bar{OE}_1 and \bar{OE}_2) are LOW, the data in the register is presented to the Q_n outputs. When one or both \bar{OE}_n inputs are HIGH, the outputs are forced to a high impedance OFF-state. The 3-state output buffers are completely independent of the register operation; the \bar{OE}_n transition does not affect the clock and reset operations.

QUICK REFERENCE DATA

GND = 0 V; T_{amb} = 25 °C; t_r = t_f = 6 ns

SYMBOL	PARAMETER	CONDITIONS	TYPICAL		UNIT
			HC	HCT	
t _{PHL} / t _{PLH}	propagation delay CP to Q _n MR to Q _n	C _L = 15 pF; V _{CC} = 5 V	17	17	ns
			13	17	ns
f _{max}	maximum clock frequency		88	88	MHz
C _I	input capacitance		3.5	3.5	pF
C _{PD}	power dissipation capacitance per flip-flop	notes 1 and 2	20	20	pF

Notes

1. C_{PD} is used to determine the dynamic power dissipation (P_D in μW):

$$P_D = C_{PD} \times V_{CC}^2 \times f_i + \sum (C_L \times V_{CC}^2 \times f_o) \text{ where:}$$

f_i = input frequency in MHz

f_o = output frequency in MHz

$\sum (C_L \times V_{CC}^2 \times f_o)$ = sum of outputs

C_L = output load capacitance in pF

V_{CC} = supply voltage in V

2. For HC the condition is V_I = GND to V_{CC}
For HCT the condition is V_I = GND to V_{CC} -1.5 V

ORDERING INFORMATION

See "74HC/HCT/HCU/HCMOS Logic Package Information".

Quad D-type flip-flop; positive-edge trigger; 3-state

74HC/HCT173

PIN DESCRIPTION

PIN NO.	SYMBOL	NAME AND FUNCTION
1, 2	$\overline{OE}_1, \overline{OE}_2$	output enable input (active LOW)
3, 4, 5, 6	Q_0 to Q_3	3-state flip-flop outputs
7	CP	clock input (LOW-to-HIGH, edge-triggered)
8	GND	ground (0 V)
9, 10	$\overline{E}_1, \overline{E}_2$	data enable inputs (active LOW)
14, 13, 12, 11	D_0 to D_3	data inputs
15	MR	asynchronous master reset (active HIGH)
16	V_{CC}	positive supply voltage

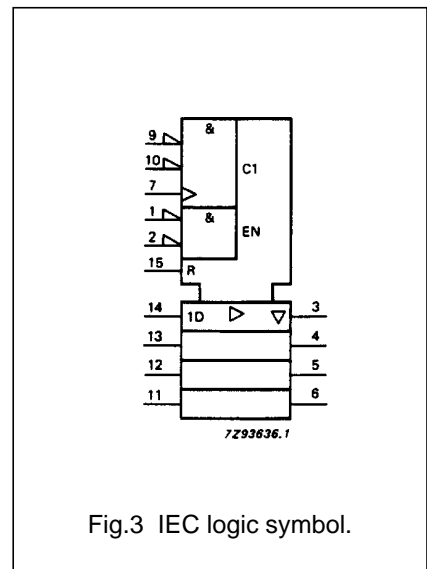
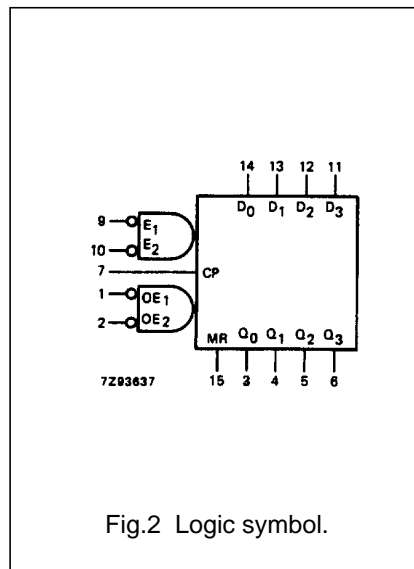
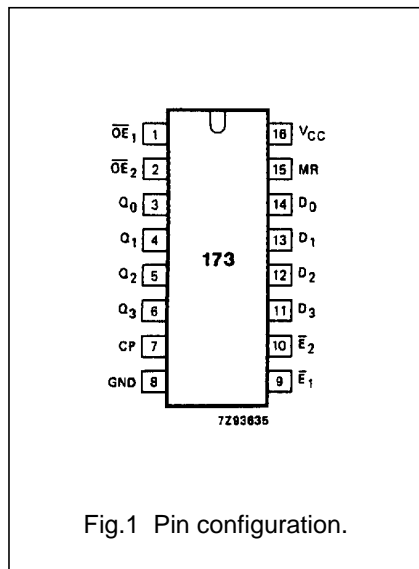

Quad D-type flip-flop; positive-edge trigger; 3-state

74HC/HCT173

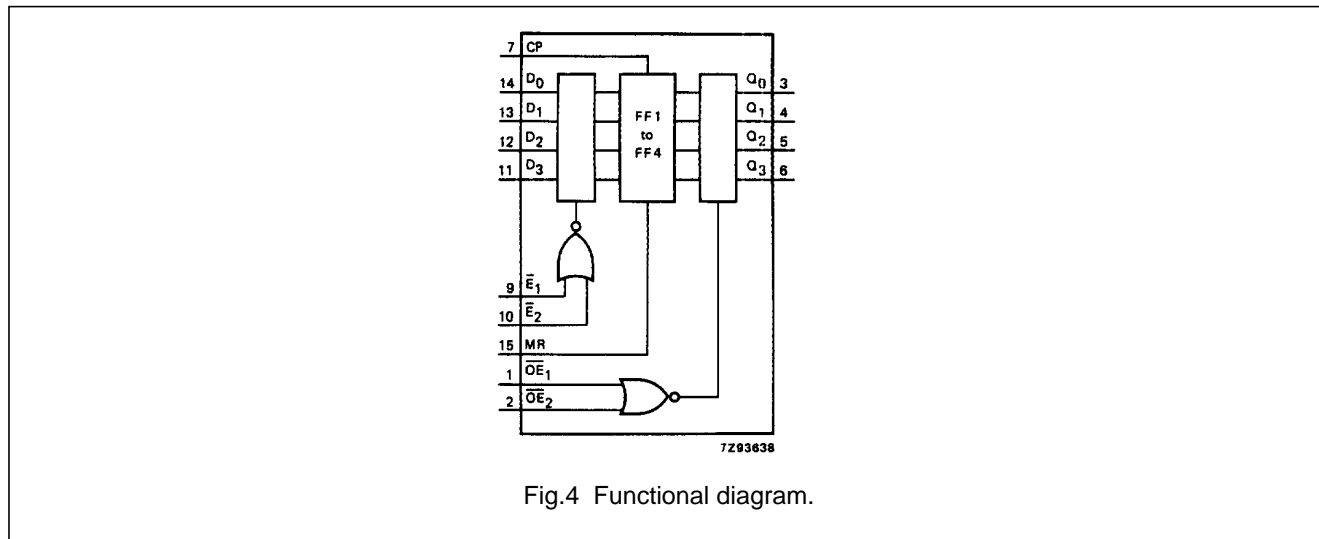

Fig.4 Functional diagram.

FUNCTION TABLE

REGISTER OPERATING MODES	INPUTS					OUTPUTS
	MR	CP	\bar{E}_1	\bar{E}_2	D_n	Q_n (register)
reset (clear)	H	X	X	X	X	L
parallel load	L	↑	l	l	l	L
	L	↑	l	l	h	H
hold (no change)	L	X	h	X	X	q_n
	L	X	X	h	X	q_n

3-STATE BUFFER OPERATING MODES	INPUTS			OUTPUTS			
	Q_n (register)	\overline{OE}_1	\overline{OE}_2	Q_0	Q_1	Q_2	Q_3
read	L	L	L	L	L	L	L
	H	L	L	H	H	H	H
disabled	X	H	X	Z	Z	Z	Z
	X	X	H	Z	Z	Z	Z

Notes

- H = HIGH voltage level
 h = HIGH voltage level one set-up time prior to the LOW-to-HIGH CP transition
 L = LOW voltage level
 l = LOW voltage level one set-up time prior to the LOW-to-HIGH CP transition
 q = lower case letters indicate the state of the referenced input (or output)
 one set-up time prior to the LOW-to-HIGH CP transition
 X = don't care
 Z = high impedance OFF-state
 ↑ = LOW-to-HIGH CP transition

Quad D-type flip-flop; positive-edge trigger; 3-state

74HC/HCT173

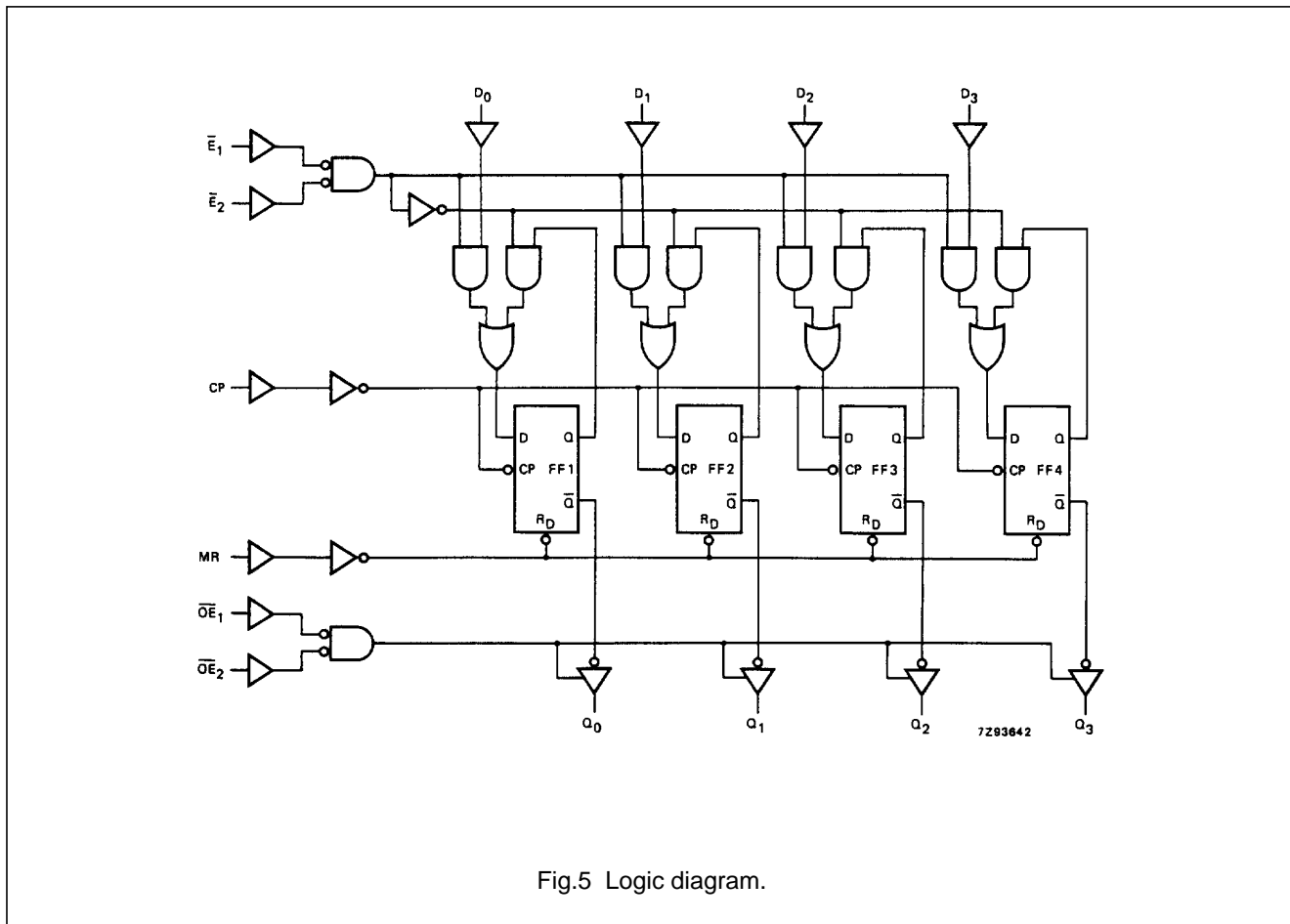

Fig.5 Logic diagram.

Quad D-type flip-flop; positive-edge trigger; 3-state

74HC/HCT173

DC CHARACTERISTICS FOR 74HC

For the DC characteristics see *"74HC/HCT/HCU/HCMOS Logic Family Specifications"*.

Output capability: bus driver

I_{CC} category: MSI

AC CHARACTERISTICS FOR 74HC

GND = 0 V; t_r = t_f = 6 ns; C_L = 50 pF

SYMBOL	PARAMETER	T _{amb} (°C)						UNIT	TEST CONDITIONS		
		74HC							V _{CC} (V)	WAVEFORMS	
		+25			-40 to +85		-40 to +125				
		min.	typ.	max.	min.	max.	min.				max.
t _{PHL} / t _{PLH}	propagation delay CP to Q _n		55 20 16	175 35 30		220 44 37		265 53 45	ns	2.0 4.5 6.0	Fig.6
t _{PHL}	propagation delay MR to Q _n		44 16 13	150 30 26		190 38 33		225 45 38	ns	2.0 4.5 6.0	Fig.7
t _{PZH} / t _{PZL}	3-state output enable time \overline{OE}_n to Q _n		52 19 15	150 30 26		190 38 33		225 45 38	ns	2.0 4.5 6.0	Fig.8
t _{PHZ} / t _{PLZ}	3-state output disable time \overline{OE}_n to Q _n		52 19 15	150 30 26		190 38 33		225 45 38	ns	2.0 4.5 6.0	Fig.8
t _{THL} / t _{TLH}	output transition time		14 5 4	60 12 10		75 15 13		90 18 15	ns	2.0 4.5 6.0	Fig.6
t _w	clock pulse width HIGH or LOW	80 16 14	14 5 4		100 20 17		120 24 20		ns	2.0 4.5 6.0	Fig.6
t _w	master reset pulse width; HIGH	80 16 14	14 5 4		100 20 17		120 24 20		ns	2.0 4.5 6.0	Fig.7
t _{rem}	removal time MR to CP	60 12 10	-8 -3 -2		75 15 13		90 18 15		ns	2.0 4.5 6.0	Fig.7
t _{su}	set-up time \overline{E}_n to CP	100 20 17	33 12 10		125 25 21		150 30 26		ns	2.0 4.5 6.0	Fig.9
t _{su}	set-up time D _n to CP	60 12 10	17 6 5		75 15 13		90 18 15		ns	2.0 4.5 6.0	Fig.9

Quad D-type flip-flop; positive-edge trigger; 3-state

74HC/HCT173

SYMBOL	PARAMETER	T _{amb} (°C)							UNIT	TEST CONDITIONS	
		74HC								V _{CC} (V)	WAVEFORMS
		+25			-40 to +85		-40 to +125				
		min.	typ.	max.	min.	max.	min.	max.			
t _h	hold time E _n to CP	0	-17		0		0		ns	2.0	Fig.9
		0	-6		0		0			4.5	
		0	-5		0		0			6.0	
t _h	hold time D _n to CP	1	-11		1		1		ns	2.0	Fig.9
		1	-4		1		1			4.5	
		1	-3		1		1			6.0	
f _{max}	maximum clock pulse frequency	6.0	26		4.8		4.0		MHz	2.0	Fig.6
		30	80		24		20			4.5	
		35	95		28		24			6.0	

Quad D-type flip-flop; positive-edge trigger; 3-state

74HC/HCT173

DC CHARACTERISTICS FOR 74HCT

For the DC characteristics see *"74HC/HCT/HCU/HCMOS Logic Family Specifications"*.

Output capability: bus driver

I_{CC} category: MSI

Note to HCT types

The value of additional quiescent supply current (ΔI_{CC}) for a unit load of 1 is given in the family specifications. To determine ΔI_{CC} per input, multiply this value by the unit load coefficient shown in the table below.

INPUT	UNIT LOAD COEFFICIENT
$\overline{OE}_1, \overline{OE}_2$	0.50
MR	0.60
$\overline{E}_1, \overline{E}_2$	0.40
D _n	0.25
CP	1.00

Quad D-type flip-flop; positive-edge trigger; 3-state

74HC/HCT173

AC CHARACTERISTICS FOR 74HCTGND = 0 V; $t_r = t_f = 6$ ns; $C_L = 50$ pF

SYMBOL	PARAMETER	T _{amb} (°C)						UNIT	TEST CONDITIONS		
		74HCT							V _{CC} (V)	WAVEFORMS	
		+25			-40 to +85		-40 to +125				
		min.	typ.	max.	min.	max.	min.				max.
t _{PHL} / t _{PLH}	propagation delay CP to Q _n		20	40		50		60	ns	4.5	Fig.6
t _{PHL}	propagation delay MR to Q _n		20	37		46		56	ns	4.5	Fig.7
t _{PZH} / t _{PZL}	3-state output enable time \overline{OE}_n to Q _n		20	35		44		53	ns	4.5	Fig.8
t _{PHZ} / t _{PLZ}	3-state output disable time \overline{OE}_n to Q _n		19	30		38		45	ns	4.5	Fig.8
t _{THL} / t _{TLH}	output transition time		5	12		15		19	ns	4.5	Fig.6
t _W	clock pulse width HIGH or LOW	16	7		20		24		ns	4.5	Fig.6
t _W	master reset pulse width; HIGH	15	6		19		22		ns	4.5	Fig.7
t _{rem}	removal time MR to CP	12	-2		15		18		ns	4.5	Fig.7
t _{su}	set-up time \overline{E}_n to CP	22	13		28		33		ns	4.5	Fig.9
t _{su}	set-up time D _n to CP	12	7		15		18		ns	4.5	Fig.9
t _h	hold time \overline{E}_n to CP	0	-6		0		0		ns	4.5	Fig.9
t _h	hold time D _n to CP	0	-3		0		0		ns	4.5	Fig.9
f _{max}	maximum clock pulse frequency	30	80		24		20		MHz	4.5	Fig.6

Quad D-type flip-flop; positive-edge trigger;
3-state

74HC/HCT173

AC WAVEFORMS

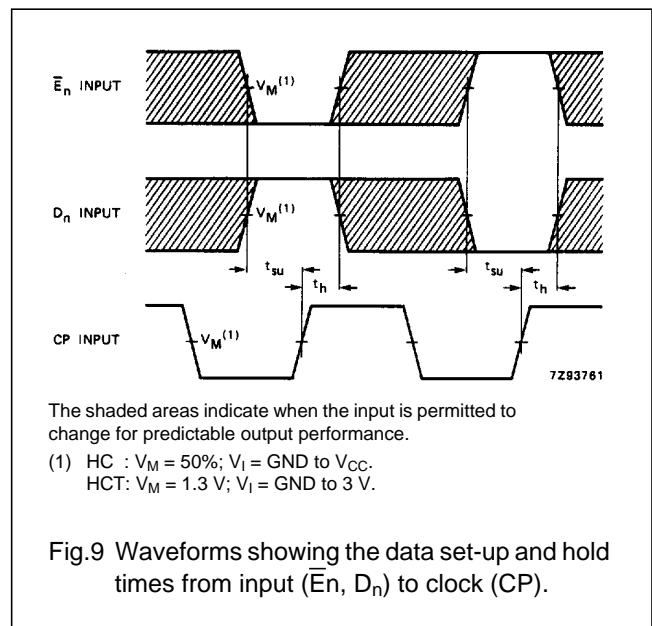
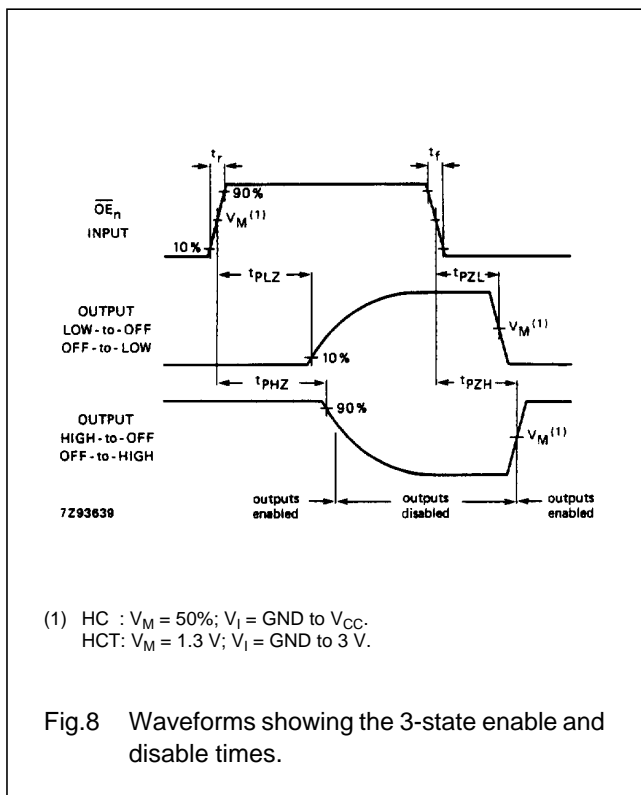
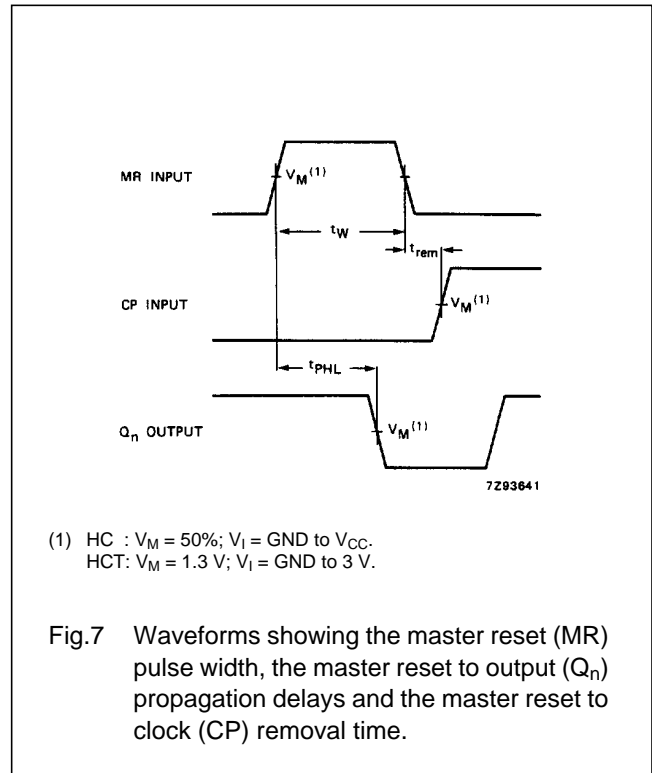
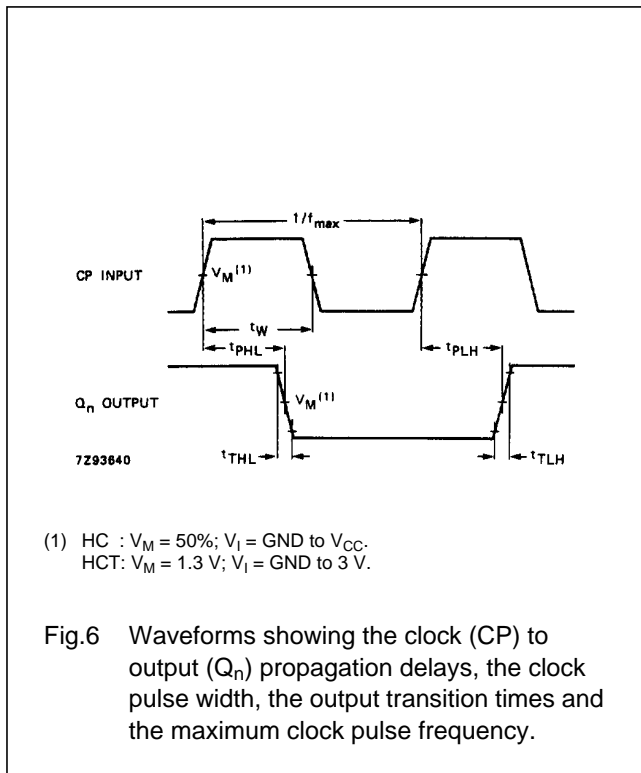

PACKAGE OUTLINES

See "74HC/HCT/HCU/HCMOS Logic Package Outlines".

X-ON Electronics

Largest Supplier of Electrical and Electronic Components

Click to view similar products for [Flip Flops](#) category:

Click to view products by [NXP](#) manufacturer:

Other Similar products are found below :

[5962-8955201EA](#) [MC74HC11ADTG](#) [MC10EP29MNG](#) [MC74HC11ADTR2G](#) [NLV14013BDTR2G](#) [NLV14027BDG](#) [NLX1G74MUTCG](#)
[703557B](#) [746431H](#) [5962-90606022A](#) [5962-9060602FA](#) [NLV14013BDR2G](#) [M38510/30104BDA](#) [M38510/07106BFA](#) [M38510/06102BFA](#)
[M38510/06101B2A](#) [NLV74HC74ADR2G](#) [TC4013BP\(N,F\)](#) [NLV14013BDG](#) [NLV74AC32DR2G](#) [NLV74AC74DR2G](#) [MC74HC73ADG](#)
[CY74FCT16374CTPACT](#) [MC74HC11ADR2G](#) [74LVT74D,118](#) [74VHCT9273FT\(BJ\)](#) [MM74HC374WM](#) [74ALVCH162374PAG](#)
[TC7WZ74FK,LJ\(CT](#) [CD54HCT273F](#) [HMC853LC3TR](#) [HMC723LC3CTR](#) [MM74HCT574MTCX](#) [MM74HCT273WM](#) [SN74LVC74APW](#)
[SN74LVC74AD](#) [MC74HC73ADTR2G](#) [MC74HC11ADG](#) [SN74ALVTH16374GR](#) [M74HCT273B1R](#) [M74HC377RM13TR](#)
[M74HC374RM13TR](#) [M74HC175B1R](#) [M74HC174RM13TR](#) [74ALVTH16374ZQLR](#) [74ALVTH32374ZKER](#) [74AUP1G74DC,125](#)
[74VHC374FT\(BJ\)](#) [74VHC9273FT\(BJ\)](#) [NLV14013BCPG](#)