

2ch VOLTAGE DETECTOR

■ GENERAL DESCRIPTION

The NJU7710/11 is a 2ch low quiescent current voltage detector featuring high precision detection voltage.

The detection voltage is internally fixed with an accuracy of 1.0%.

NJU7710 is Nch. Open Drain and NJU7711 is a C-MOS output type.

■ PACKAGE OUTLINE

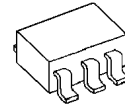

NJU7710/11F



NJU7710/11F3

■ FEATURES

- High Precision detection Voltage ±1.0%
- Low Quiescent Current 0.8μA typ. (per 1CH)
- Detection Voltage Range 1.3–6.0V(0.1V step)
- Output Configuration NJU7710: Nch. Open Drain Type
- NJU7711: C-MOS Output Type
- Package Outline SOT-23-5 / SC88A

■ PIN CONFIGURATION

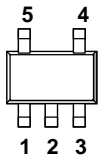

PIN FUNCTION

1. V_{OUT1}
2. V_{SS}
3. V_{DD1}
4. V_{DD2}
5. V_{OUT2}

NJU7710F/F3, NJU7711F/F3

■ EQUIVALENT CIRCUIT

NJU7710

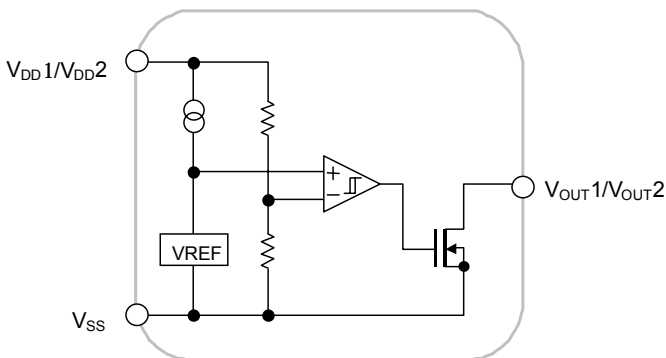

NJU7711

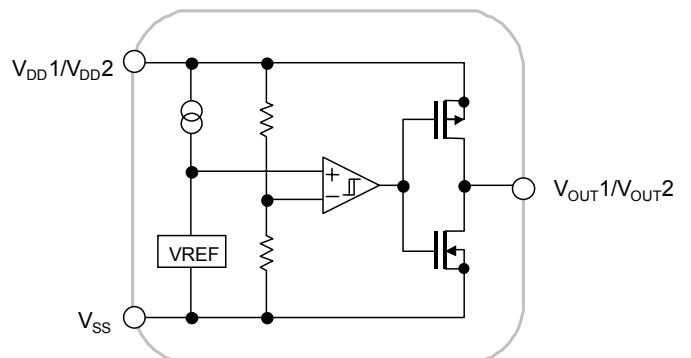

NJU7710/11

■ DETECTION VOLTAGERANK LIST

NJU7710

Device Name	Package	V _{DET}	
		CH1	CH2
NJU7710F1524	SOT-23-5	1.5V	2.4V
NJU7710F2318		2.3V	1.8V
NJU7710F0435		4.0V	3.5V
NJU7710F4227		4.2V	2.7V
NJU7710F0613		6.0V	1.3V
NJU7710F3-1524	SC88A	1.5V	2.4V
NJU7710F3-2318		2.3V	1.8V
NJU7710F3-0435		4.0V	3.5V
NJU7710F3-4227		4.2V	2.7V
NJU7710F3-0613		6.0V	1.3V

NJU7711

Device Name	Package	V _{DET}	
		CH1	CH2
NJU7711F4219	SOT-23-5	4.2V	1.9V
NJU7711F4227		4.2V	2.7V
NJU7711F0613		6.0V	1.3V
NJU7711F3-4219	SC88A	4.2V	1.9V
NJU7711F3-4227		4.2V	2.7V
NJU7711F3-0613		6.0V	1.3V

■ NJU7710

■ ABSOLUTE MAXIMUM RATINGS (Ta=25°C)

PARAMETER	SYMBOL	RATINGS		UNIT
Input Voltage	V _{DD}	+10		V
Output Voltage	V _{OUT}	V _{SS} -0.3 ~ +10		V
Output Current	I _{OUT}	50		mA
Power Dissipation	P _D	SOT-23-5	350(*1)	mW
			200(*2)	
		SC88A	250(*1)	
Operating Temperature	Topr	-40 ~ +85		°C
Storage Temperature	Tstg	-40 ~ +125		°C

(*1) : Mounted on glass epoxy board based on EIA/JEDEC. (114.3x76.2x1.6mm: 2Layers)

(*2) : Device itself

■ ELECTRICAL CHARACTERISTICS

(CH1/2 common characteristics, Ta=25°C)

PARAMETER	SYMBOL	TEST CONDITION	MIN.	TYP.	MAX.	UNIT	
Detection Voltage	V _{DET}		-1.0%	-	+1.0%	V	
Hysteresis Voltage	V _{HYS}		V _{DET} ×0.03	V _{DET} ×0.05	V _{DET} ×0.08	V	
Quiescent Current	I _{SS}	V _{DD} =V _{DET} +1V	V _{DET} =1.3V~1.7V Version	-	0.5	1.0	μA
			V _{DET} =1.8V~6.0V Version	-	0.8	1.6	μA
Output Current	I _{OUT}	Nch, V _{DS} =0.5V	V _{DD} =1.2V	0.75	2.0	-	mA
			V _{DD} =2.4V (≥2.7V Version)	4.5	7.0	-	mA
Output Leak Current	I _{LEAK}	V _{DD} =V _{OUT} =9V	-	-	0.1	μA	
Detection Voltage Temperature Coefficient	ΔV _{DET} /ΔTa	Ta=0 ~ +85°C	-	±100	-	ppm/°C	
Operating Voltage (*3)	V _{DD}	R _L =100kΩ	0.8	-	9	V	

(*3): The minimum Operating Voltage(V_{OPL}) indicates the same value of the input voltage(V_{DD}) on condition that V_{OUT} becomes 10% or less of the input voltage(V_{DD}).

NJU7710/11

■ TEST CIRCUIT

① COMMON TEST CIRCUIT

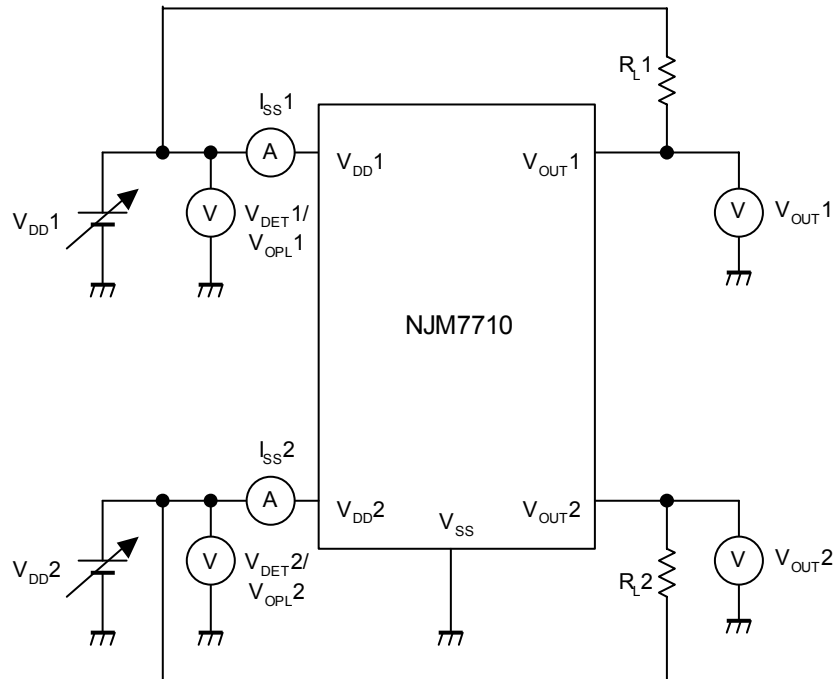

② Output Current/Output Leak Current TEST CIRCUIT

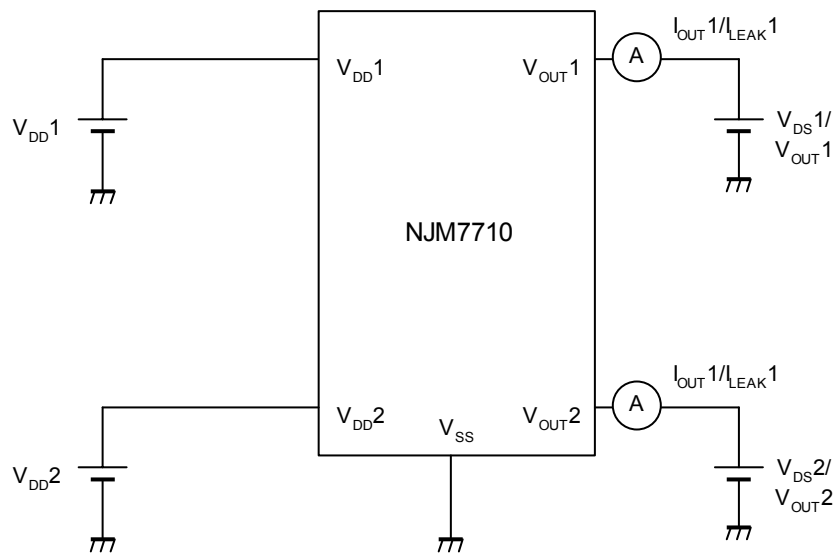

■ TYPICAL APPLICATION

① Power supply voltage supervision of two systems

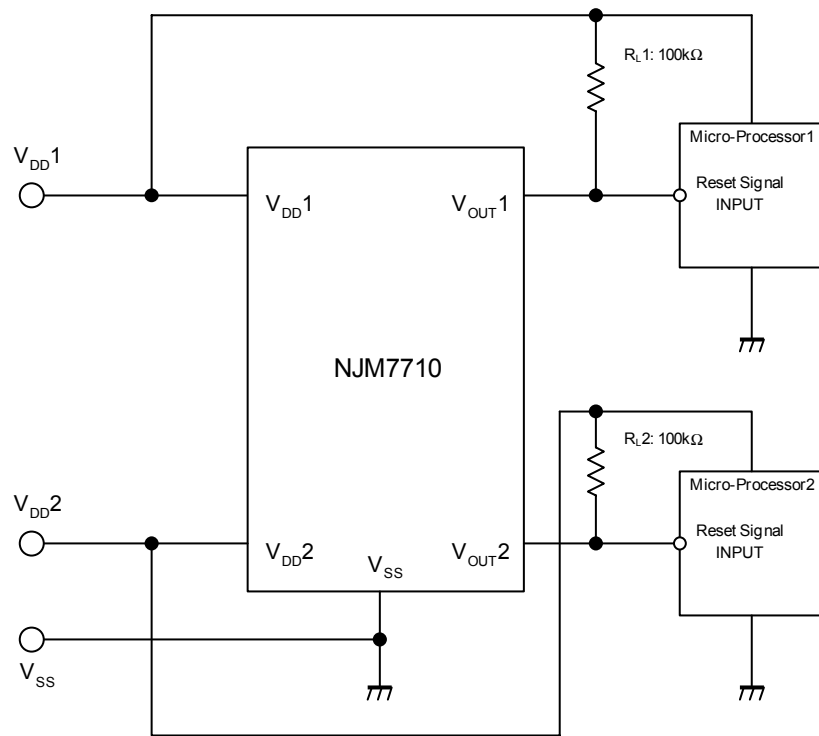

② Power supply voltage supervision of two systems

(At the time of power source supply classified by micro-processor)

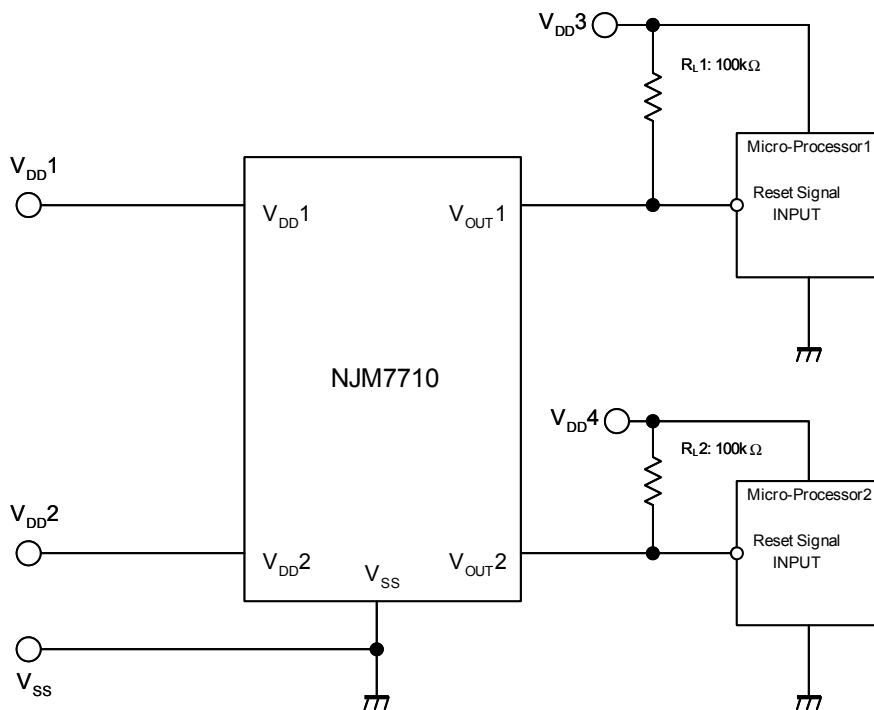

NJU7710/11

■ NJU7711

■ ABSOLUTE MAXIMUM RATINGS (Ta=25°C)

PARAMETER	SYMBOL	RATINGS		UNIT
Input Voltage	V _{DD}	+10		V
Output Voltage	V _{OUT}	V _{SS} -0.3 ~ V _{DD} +0.3		V
Output Current	I _{OUT}	50		mA
Power Dissipation	P _D	SOT-23-5	350(*4)	mW
			200(*5)	
		SC88A	250(*4)	
Operating Temperature	Topr	-40 ~ +85		°C
Storage Temperature	Tstg	-40 ~ +125		°C

(*4) : Mounted on glass epoxy board based on EIA/JEDEC. (114.3x76.2x1.6mm: 2Layers)

(*5) : Device itself

■ ELECTRICAL CHARACTERISTICS

(CH1/2 common characteristics. Ta=25°C)

PARAMETER	SYMBOL	TEST CONDITION		MIN.	TYP.	MAX.	UNIT
Detection Voltage	V _{DET}			-1.0%	-	+1.0%	V
Hysteresis Voltage	V _{HYS}			V _{DET} x0.03	V _{DET} x0.05	V _{DET} x0.08	V
Quiescent Current	I _{SS}	V _{DD} =V _{DET} +1V	V _{DET} =1.3V~1.7V Version	-	0.5	1.0	μA
			V _{DET} =1.8V~6V Version	-	0.8	1.6	μA
Output Current	I _{OUT}	Nch, V _{DS} =0.5V	V _{DD} =1.2V	0.75	2.0	-	mA
			V _{DD} =2.4V (≥2.7V Version)	4.5	7.0	-	mA
		Pch, V _{DS} =0.5V	V _{DD} =4.8V (≤3.9V Version)	2.0	3.5	-	mA
			V _{DD} =6.0V (4V~5.6V Version)	2.5	4.0	-	mA
		V _{DD} =8.4V (≥5.7V Version)	3.0	5.0	-	mA	
Detection Voltage Temperature Coefficient	ΔV _{DET} /ΔTa	Ta=0 ~ +85°C		-	±100	-	ppm/°C
Operating Voltage (*6)	V _{DD}	R _L =100kΩ		0.8	-	9	V

(*6): The minimum Operating Voltage(V_{OPL}) indicates the same value of the output voltage(V_{OUT}) on condition that V_{OUT} becomes 10% or less of the input voltage(V_{DD}).

■ TEST CIRCUIT

① COMMON TEST CIRCUIT

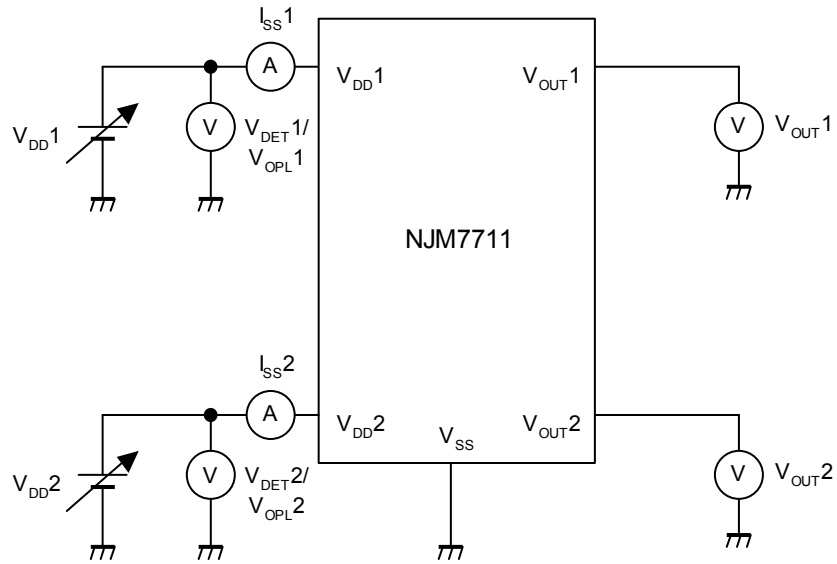

② Nch Output Current TEST CIRCUIT

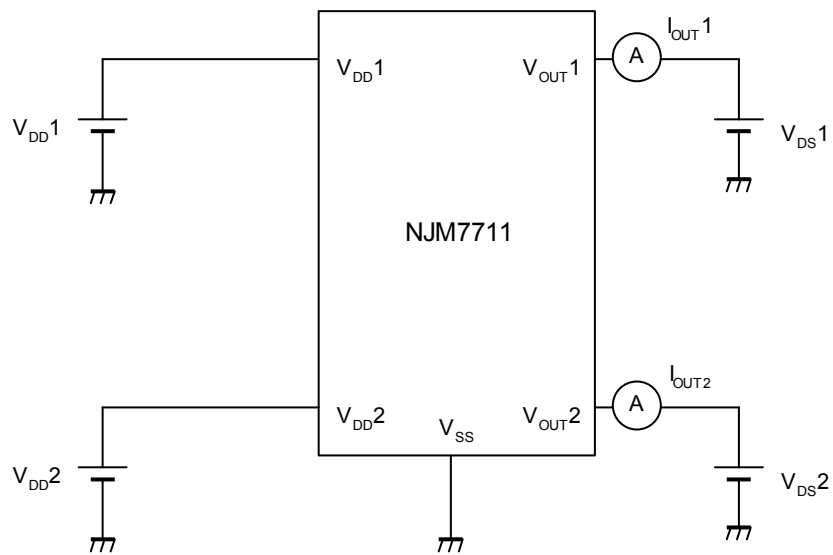

③ Pch Output Current TEST CIRCUIT

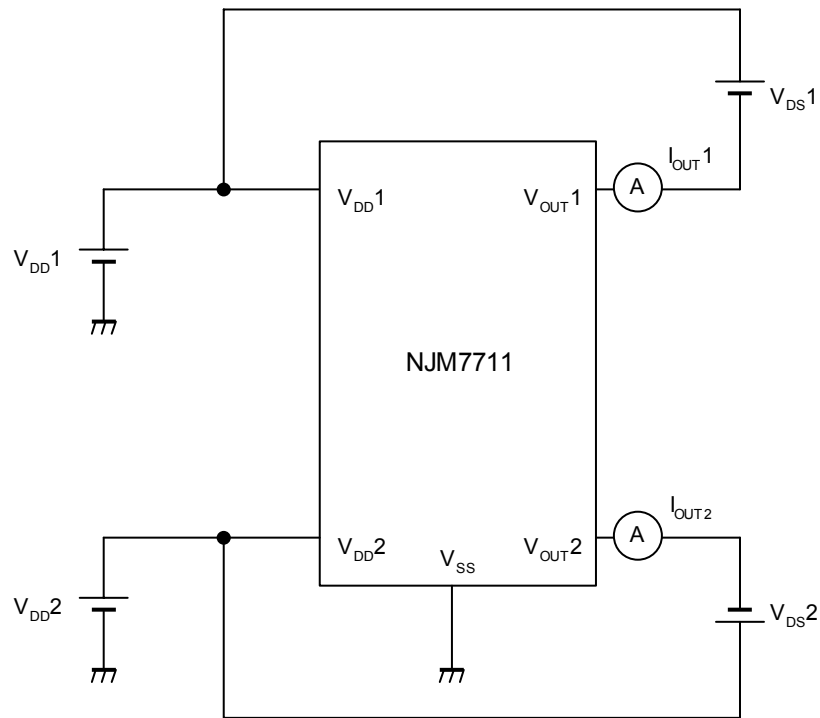

④ Minimum Operating Voltage TEST CIRCUIT

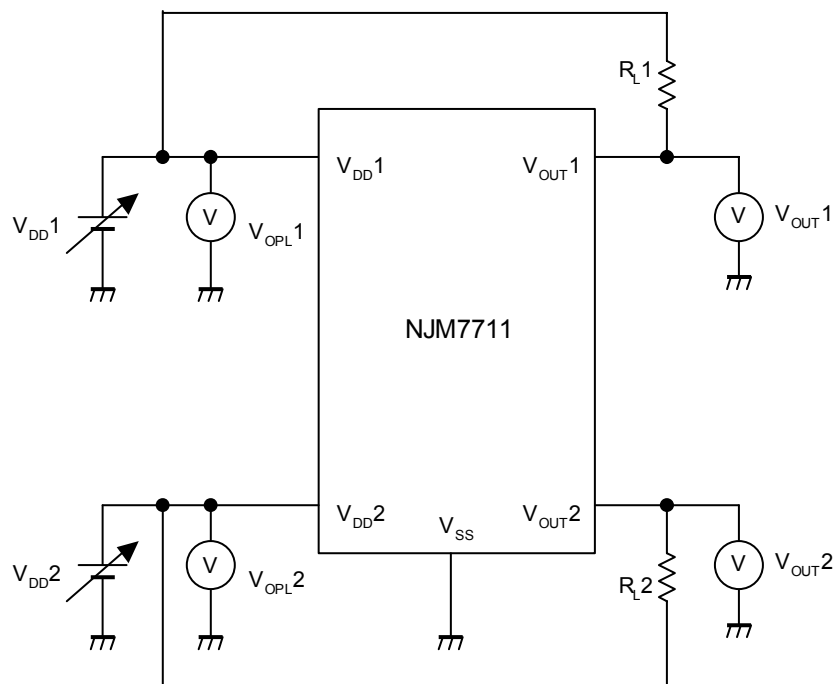

■ TYPICAL APPLICATION

Power supply voltage supervision of two systems

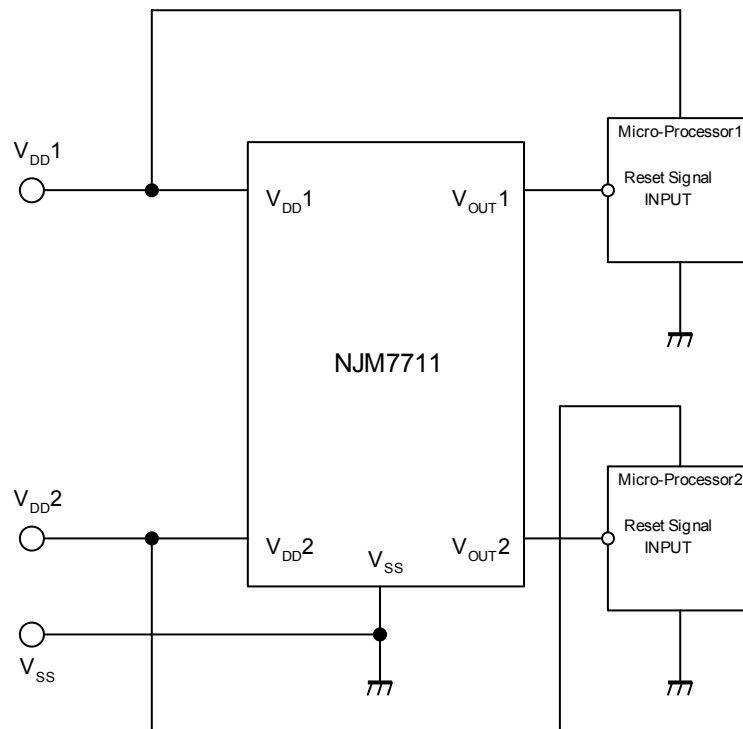

[CAUTION]

The specifications on this databook are only given for information, without any guarantee as regards either mistakes or omissions. The application circuits in this databook are described only to show representative usages of the product and not intended for the guarantee or permission of any right including the industrial rights.

X-ON Electronics

Largest Supplier of Electrical and Electronic Components

Click to view similar products for [Supervisory Circuits](#) category:

Click to view products by [NJR](#) manufacturer:

Other Similar products are found below :

[NCP304LSQ38T1G](#) [NCP304LSQ40T1G](#) [NCP304LSQ42T1G](#) [NCP304LSQ43T1G](#) [NCP304LSQ46T1G](#) [NCP305LSQ11T1G](#)
[NCP305LSQ16T1G](#) [NCP305LSQ17T1G](#) [NCP305LSQ18T1G](#) [NCP305LSQ24T1G](#) [NCP305LSQ25T1G](#) [NCP305LSQ29T1G](#)
[NCP305LSQ31T1G](#) [NCP305LSQ32T1G](#) [NCP308MT250TBG](#) [NCP308SN300T1G](#) [NCP391FCALT2G](#) [NCV303LSN42T1G](#)
[NCV308SN330T1G](#) [CAT1161LI-25-G](#) [CAT853STBI-T3](#) [MAX1232CPA](#) [MAX705CPA](#) [CAT1026LI-30-G](#) [CAT1320LI-25-G](#) [CAT872-30ULGT3](#) [LA-ispPAC-POWR1014-01TN48E](#) [NCP304HSQ18T1G](#) [NCP304HSQ29T1G](#) [NCP304LSQ27T1G](#) [NCP304LSQ29T1G](#)
[NCP304LSQ45T1G](#) [NCP305LSQ26T1G](#) [NCP305LSQ35T1G](#) [NCP305LSQ37T1G](#) [NCP308MT300TBG](#) [NCV300LSN36T1G](#)
[NCV302LSN30T1G](#) [NCV303LSN16T1G](#) [NCV303LSN22T1G](#) [NCV303LSN27T1G](#) [NCV33161DMR2G](#) [TC54VN2402EMB713](#)
[MCP1316T-44NE/OT](#) [MCP1316MT-45GE/OT](#) [MCP1316MT-23LI/OT](#) [MCP1316T-26LE/OT](#) [MAX8997EWW+](#) [MAX821RUS+T](#)
[MAX6725AKASYD3-LF-T](#)