

SOJ, TSOP, FP-BGA  
Commercial Temp  
Industrial Temp

## 64K x 16

# 1Mb Asynchronous SRAM

7, 8, 10, 12 ns  
3.3 V  $V_{DD}$   
Center  $V_{DD}$  and  $V_{SS}$

### Features

- Fast access time: 7, 8, 10, 12 ns
- CMOS low power operation: 145/125/100/85 mA at minimum cycle time
- Single 3.3 V power supply
- All inputs and outputs are TTL-compatible
- Byte control
- Fully static operation
- Industrial Temperature Option:  $-40^{\circ}$  to  $85^{\circ}\text{C}$
- Package line up
  - J: 400 mil, 44-pin SOJ package
  - GJ: RoHS-compliant 400 mil, 44-pin SOJ package
  - TP: 400 mil, 44-pin TSOP Type II package
  - GP: RoHS-compliant 400 mil, 44-pin TSOP Type II package
  - U: 6 mm x 8 mm Fine Pitch Ball Grid Array package
  - GU: RoHS-compliant 6 mm x 8 mm Fine Pitch Ball Grid Array package

### Description

The GS71116A is a high speed CMOS static RAM organized as 65,536-words by 16-bits. Static design eliminates the need for external clocks or timing strobes. Operating on a single 3.3 V power supply and all inputs and outputs are TTL-compatible. The GS71116A is available in a 6 mm x 8 mm Fine Pitch BGA package, as well as in 400 mil SOJ and 400 mil TSOP Type-II packages

### Pin Descriptions

| Symbol                            | Description                           |
|-----------------------------------|---------------------------------------|
| A <sub>0</sub> –A <sub>15</sub>   | Address input                         |
| DQ <sub>1</sub> –DQ <sub>16</sub> | Data input/output                     |
| $\overline{\text{CE}}$            | Chip enable input                     |
| $\overline{\text{LB}}$            | Lower byte enable input (DQ1 to DQ8)  |
| $\overline{\text{UB}}$            | Upper byte enable input (DQ9 to DQ16) |
| $\overline{\text{WE}}$            | Write enable input                    |
| $\overline{\text{OE}}$            | Output enable input                   |
| $V_{DD}$                          | +3.3 V power supply                   |
| $V_{SS}$                          | Ground                                |
| NC                                | No connect                            |

### SOJ 64K x 16-Pin Configuration

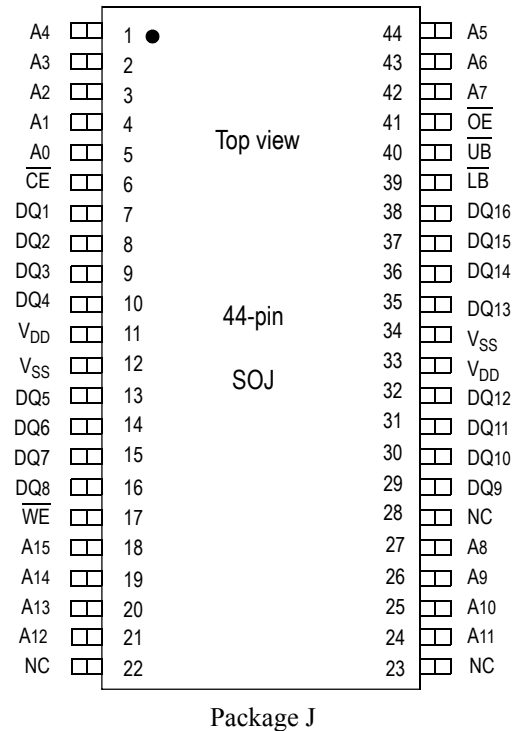

### Fine Pitch BGA 64K x 16-Bump Configuration

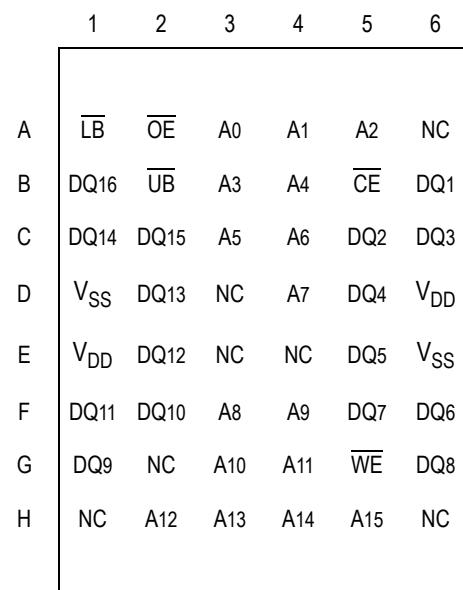

### TSOP-II 64K x 16-Pin Configuration

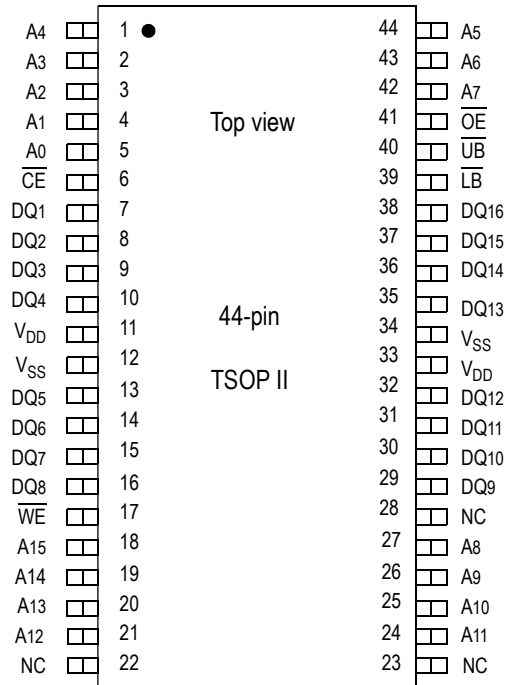

Package TP

### Block Diagram

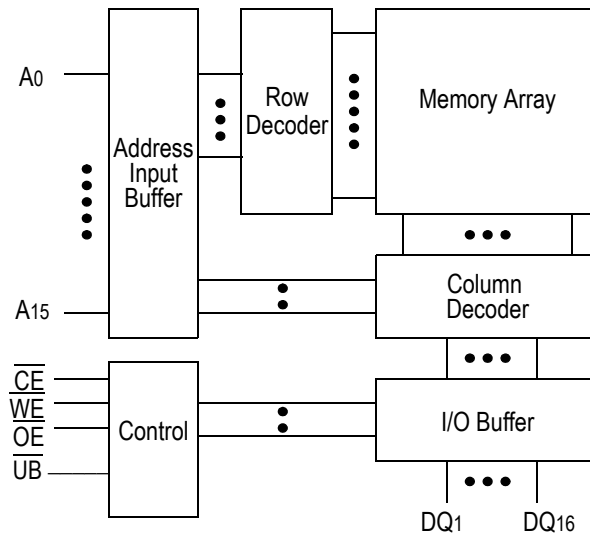

**Truth Table**

| $\overline{CE}$ | $\overline{OE}$ | $\overline{WE}$ | $\overline{LB}$ | $\overline{UB}$ | DQ1 to DQ8        | DQ9 to DQ16       | $V_{DD}$ Current |
|-----------------|-----------------|-----------------|-----------------|-----------------|-------------------|-------------------|------------------|
| H               | X               | X               | X               | X               | Not Selected      | Not Selected      | ISB1, ISB2       |
| L               | L               | H               | L               | L               | Read              | Read              | I <sub>DD</sub>  |
|                 |                 |                 | L               | H               | Read              | High Z            |                  |
|                 |                 |                 | H               | L               | High Z            | Read              |                  |
| L               | X               | L               | L               | L               | Write             | Write             |                  |
|                 |                 |                 | L               | H               | Write             | Not Write, High Z |                  |
|                 |                 |                 | H               | L               | Not Write, High Z | Write             |                  |
| L               | H               | H               | X               | X               | High Z            | High Z            |                  |
| L               | X               | X               | H               | H               | High Z            | High Z            |                  |

**Note:**

X: "H" or "L"

**Absolute Maximum Ratings**

| Parameter                   | Symbol    | Rating   | Unit |
|-----------------------------|-----------|--|------|
| Supply Voltage              | $V_{DD}$  | -0.5 to +4.6                                   | V    |
| Input Voltage               | $V_{IN}$  | -0.5 to $V_{DD} + 0.5$<br>( $\leq 4.6$ V max.) | V    |
| Output Voltage              | $V_{OUT}$ | -0.5 to $V_{DD} + 0.5$<br>( $\leq 4.6$ V max.) | V    |
| Allowable power dissipation | PD        | 0.7  | W    |
| Storage temperature         | $T_{STG}$ | -55 to 150                                     | °C   |

**Note:**

Permanent device damage may occur if Absolute Maximum Ratings are exceeded. Functional operation shall be restricted to Recommended Operating Conditions. Exposure to higher than recommended voltages for extended periods of time could affect device reliability.

### Recommended Operating Conditions

| Parameter                                | Symbol   | Min  | Typ | Max            | Unit |
|--|----------|------|-----|----------------|------|
| Supply Voltage for -7/-8/-10/-12         | $V_{DD}$ | 3.0  | 3.3 | 3.6            | V    |
| Input High Voltage                       | $V_{IH}$ | 2.0  | —   | $V_{DD} + 0.3$ | V    |
| Input Low Voltage                        | $V_{IL}$ | -0.3 | —   | 0.8            | V    |
| Ambient Temperature,<br>Commercial Range | $T_{Ac}$ | 0    | —   | 70             | °C   |
| Ambient Temperature,<br>Industrial Range | $T_{AI}$ | -40  | —   | 85             | °C   |

#### Notes:

1. Input overshoot voltage should be less than  $V_{DD} + 2V$  and not exceed 20 ns.
2. Input undershoot voltage should be greater than  $-2V$  and not exceed 20 ns.

### Capacitance

| Parameter          | Symbol    | Test Condition | Max | Unit |
|--------------------|-----------|----------------|-----|------|
| Input Capacitance  | $C_{IN}$  | $V_{IN} = 0V$  | 5   | pF   |
| Output Capacitance | $C_{OUT}$ | $V_{OUT} = 0V$ | 7   | pF   |

#### Notes:

1. Tested at  $T_A = 25^\circ\text{C}$ ,  $f = 1\text{ MHz}$
2. These parameters are sampled and are not 100% tested.

### DC I/O Pin Characteristics

| Parameter                 | Symbol   | Test Conditions                            | Min              | Max             |
|---------------------------|----------|--|------------------|-----------------|
| Input Leakage Current     | $I_{IL}$ | $V_{IN} = 0$ to $V_{DD}$                   | -1 $\mu\text{A}$ | 1 $\mu\text{A}$ |
| Output Leakage<br>Current | $I_{LO}$ | Output High Z<br>$V_{OUT} = 0$ to $V_{DD}$ | -1 $\mu\text{A}$ | 1 $\mu\text{A}$ |
| Output High Voltage       | $V_{OH}$ | $I_{OH} = -4\text{ mA}$                    | 2.4              |                 |
| Output Low Voltage        | $V_{OL}$ | $I_{LO} = +4\text{ mA}$                    |                  | 0.4V            |

## Power Supply Currents

| Parameter                | Symbol           | Test Conditions   | 0 to 70°C |        |        |       | -40 to 85°C |        |        |       |
|--------------------------|------------------|---|-----------|--------|--------|-------|-------------|--------|--------|-------|
|                          |                  |   | 7 ns      | 8 ns   | 10 ns  | 12 ns | 7 ns        | 8 ns   | 10 ns  | 12 ns |
| Operating Supply Current | I <sub>DD</sub>  | $\overline{CE} \leq V_{IL}$<br>All other inputs $\geq V_{IH}$ or $\leq V_{IL}$<br>Min. cycle time<br>$I_{OUT} = 0$ mA | 145 mA    | 125 mA | 100 mA | 85 mA | 150 mA      | 130 mA | 105 mA | 90 mA |
| Standby Current          | I <sub>SB1</sub> | $\overline{CE} \geq V_{IH}$<br>All other inputs $\geq V_{IH}$ or $\leq V_{IL}$<br>Min. cycle time                     | 25 mA     | 20 mA  | 20 mA  | 15 mA | 30 mA       | 25 mA  | 25 mA  | 20 mA |
| Standby Current          | I <sub>SB2</sub> | $\overline{CE} \geq V_{DD} - 0.2$ V<br>All other inputs $\geq V_{DD} - 0.2$ V or $\leq 0.2$ V                         | 2 mA      |        |        |       | 5 mA        |        |        |       |

## AC Test Conditions

| Parameter              | Conditions            |
|------------------------|-----------------------|
| Input high level       | $V_{IH} = 2.4$ V      |
| Input low level        | $V_{IL} = 0.4$ V      |
| Input rise time        | $t_r = 1$ V/ns        |
| Input fall time        | $t_f = 1$ V/ns        |
| Input reference level  | 1.4 V                 |
| Output reference level | 1.4 V                 |
| Output load            | <b>Fig. 1 &amp; 2</b> |

### Notes:

1. Include scope and jig capacitance.
2. Test conditions as specified with output loading as shown in Fig. 1 unless otherwise noted.
3. Output load 2 for t<sub>LZ</sub>, t<sub>HZ</sub>, t<sub>OLZ</sub> and t<sub>OZH</sub>

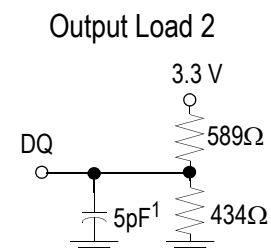
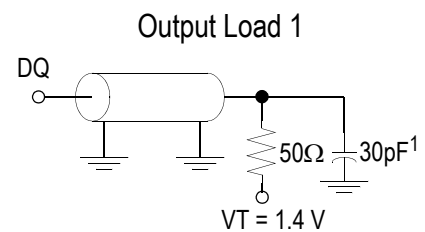

## AC Characteristics

## Read Cycle

| Parameter  | Symbol             | -7  |     | -8  |     | -10 |     | -12 |     | Unit |
|--|--------------------|-----|-----|-----|-----|-----|-----|-----|-----|------|
|  |                    | Min | Max | Min | Max | Min | Max | Min | Max |      |
| Read cycle time  | t <sub>RC</sub>    | 7   | —   | 8   | —   | 10  | —   | 12  | —   | ns   |
| Address access time  | t <sub>AA</sub>    | —   | 7   | —   | 8   | —   | 10  | —   | 12  | ns   |
| Chip enable access time ( $\overline{CE}$ )                            | t <sub>AC</sub>    | —   | 7   | —   | 8   | —   | 10  | —   | 12  | ns   |
| Byte enable access time ( $\overline{UB}$ , $\overline{LB}$ )          | t <sub>AB</sub>    | —   | 3   | —   | 3.5 | —   | 4   | —   | 5   | ns   |
| Output enable to output valid ( $\overline{OE}$ )                      | t <sub>OE</sub>    | —   | 3   | —   | 3.5 | —   | 4   | —   | 5   | ns   |
| Output hold from address change  | t <sub>OH</sub>    | 3   | —   | 3   | —   | 3   | —   | 3   | —   | ns   |
| Chip enable to output in low Z ( $\overline{CE}$ )                     | t <sub>LZ</sub> *  | 3   | —   | 3   | —   | 3   | —   | 3   | —   | ns   |
| Output enable to output in low Z ( $\overline{OE}$ )                   | t <sub>OLZ</sub> * | 0   | —   | 0   | —   | 0   | —   | 0   | —   | ns   |
| Byte enable to output in low Z ( $\overline{UB}$ , $\overline{LB}$ )   | t <sub>BLZ</sub> * | 0   | —   | 0   | —   | 0   | —   | 0   | —   | ns   |
| Chip disable to output in High Z ( $\overline{CE}$ )                   | t <sub>HZ</sub> *  | —   | 3.5 | —   | 4   | —   | 5   | —   | 6   | ns   |
| Output disable to output in High Z ( $\overline{OE}$ )                 | t <sub>OHZ</sub> * | —   | 3   | —   | 3.5 | —   | 4   | —   | 5   | ns   |
| Byte disable to output in High Z ( $\overline{UB}$ , $\overline{LB}$ ) | t <sub>BHZ</sub> * | —   | 3   | —   | 3.5 | —   | 3.5 | —   | 3.5 | —    |

\* These parameters are sampled and are not 100% tested.

Read Cycle 1:  $\overline{CE} = \overline{OE} = V_{IL}$ ,  $\overline{WE} = V_{IH}$ ,  $\overline{UB}$  and, or  $\overline{LB} = V_{IL}$

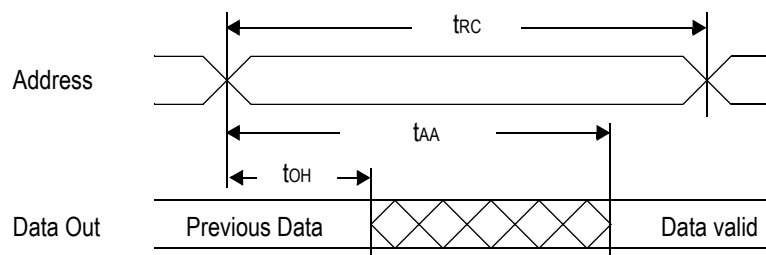

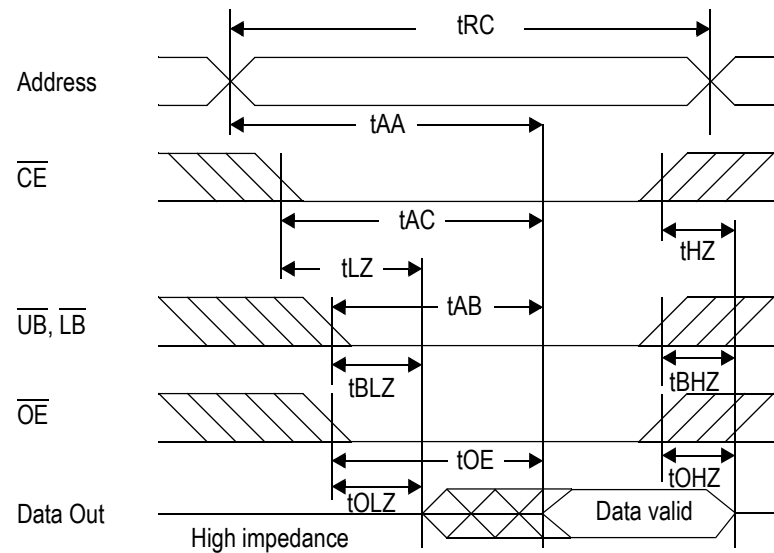
Read Cycle 2:  $\overline{WE} = V_{IH}$ 

## Write Cycle

| Parameter                               | Symbol      | -7  |     | -8  |     | -10 |     | -12 |     | Unit |
|---|-------------|-----|-----|-----|-----|-----|-----|-----|-----|------|
|   |             | Min | Max | Min | Max | Min | Max | Min | Max |      |
| Write cycle time                        | $t_{WC}$    | 7   | —   | 8   | —   | 10  | —   | 12  | —   | ns   |
| Address valid to end of write           | $t_{AW}$    | 5   | —   | 5.5 | —   | 7   | —   | 8   | —   | ns   |
| Chip enable to end of write             | $t_{CW}$    | 5   | —   | 5.5 | —   | 7   | —   | 8   | —   | ns   |
| Byte enable to end of write             | $t_{BW}$    | 5   | —   | 5.5 | —   | 7   | —   | 8   | —   | ns   |
| Data set up time                        | $t_{DW}$    | 3.5 | —   | 4   | —   | 5   | —   | 6   | —   | ns   |
| Data hold time                          | $t_{DH}$    | 0   | —   | 0   | —   | 0   | —   | 0   | —   | ns   |
| Write pulse width                       | $t_{WP}$    | 5   | —   | 5.5 | —   | 7   | —   | 8   | —   | ns   |
| Address set up time                     | $t_{AS}$    | 0   | —   | 0   | —   | 0   | —   | 0   | —   | ns   |
| Write recovery time ( $\overline{WE}$ ) | $t_{WR}$    | 0   | —   | 0   | —   | 0   | —   | 0   | —   | ns   |
| Write recovery time ( $\overline{CE}$ ) | $t_{WR1}$   | 0   | —   | 0   | —   | 0   | —   | 0   | —   | ns   |
| Output Low Z from end of write          | $t_{WLZ}^*$ | 3   | —   | 3   | —   | 3   | —   | 3   | —   | ns   |
| Write to output in High Z               | $t_{WHZ}^*$ | —   | 3   | —   | 3.5 | —   | 4   | —   | 5   | ns   |

\* These parameters are sampled and are not 100% tested.

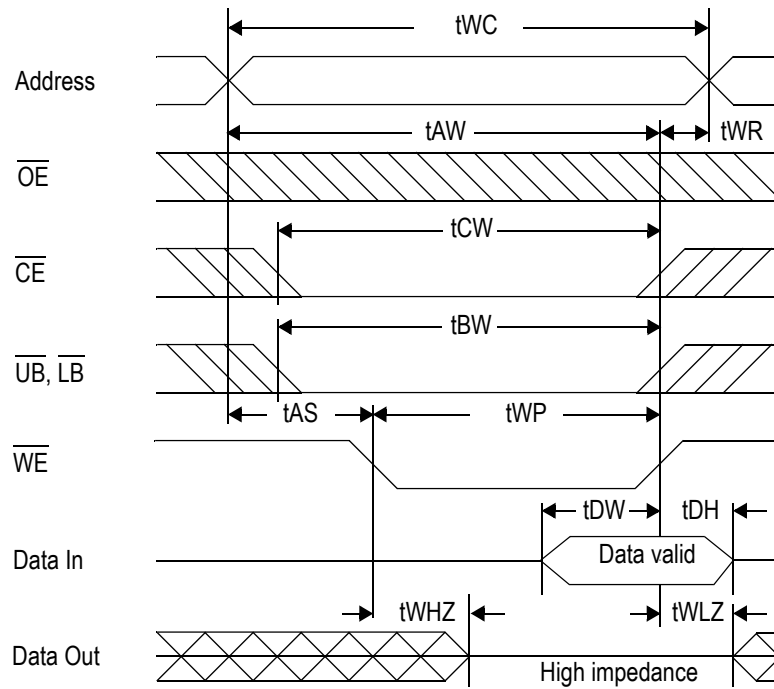
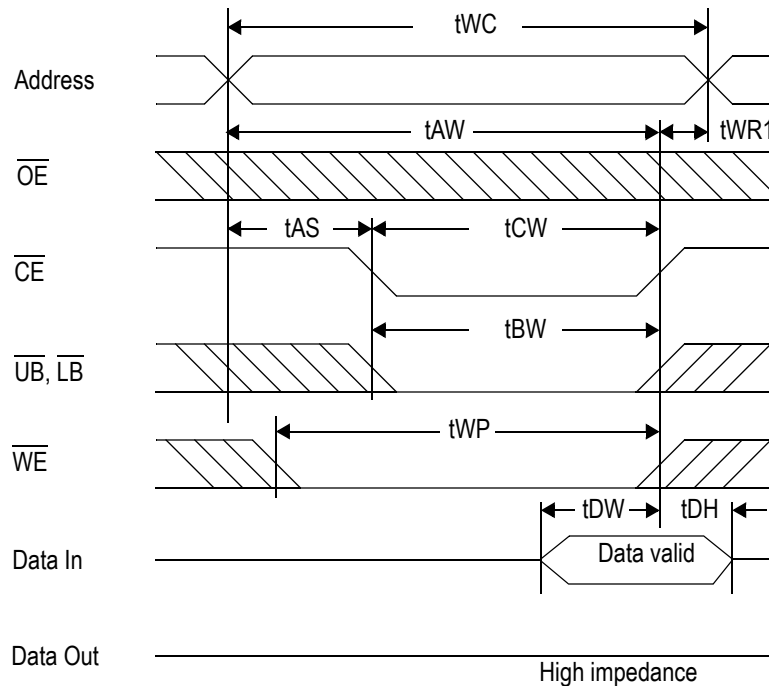
**Write Cycle 1:  $\overline{WE}$  control**

**Write Cycle 2:  $\overline{CE}$  control**

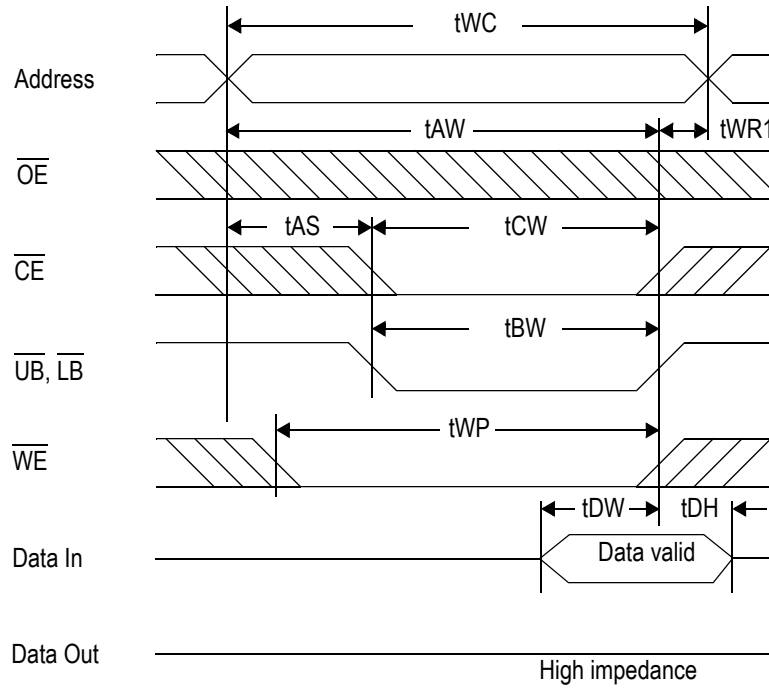

Write Cycle 3:  $\overline{UB}$ ,  $\overline{LB}$  control

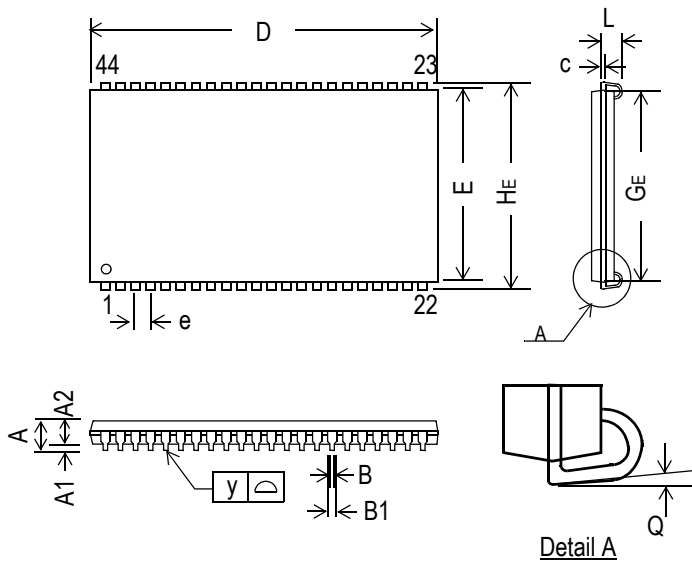

## 44-Pin, 400 mil SOJ



| Symbol | Dimension in inch |       |       | Dimension in mm |        |        |
|--------|-------------------|-------|-------|-----------------|--------|--------|
|        | min               | nom   | max   | min             | nom    | max    |
| A      | —                 | —     | 0.148 | —               | —      | 3.759  |
| A1     | 0.025             | —     | —     | 0.635           | —      | —      |
| A2     | 0.105             | 0.110 | 0.115 | 2.667           | 2.794  | 2.921  |
| B      | —                 | 0.018 | —     | —               | 0.457  | —      |
| B1     | 0.026             | 0.028 | 0.032 | 0.660           | 0.711  | 0.813  |
| c      | —                 | 0.008 | —     | —               | 0.203  | —      |
| D      | 1.120             | 1.125 | 1.130 | 28.44           | 28.58  | 28.70  |
| E      | 0.395             | 0.400 | 0.405 | 10.033          | 10.160 | 10.287 |
| e      | —                 | 0.05  | —     | —               | 1.27   | —      |
| HE     | 0.435             | 0.440 | 0.445 | 11.049          | 11.176 | 11.303 |
| GE     | 0.360             | 0.370 | 0.380 | 9.144           | 9.398  | 9.652  |
| L      | 0.082             | 0.087 | 0.106 | 2.083           | 2.210  | 2.70   |
| y      | —                 | —     | 0.004 | —               | —      | 0.102  |
| Q      | 0°                | —     | 7°    | 0°              | —      | 7°     |

**Notes:**

1. Dimension D & E do not include interlead flash.
2. Dimension B1 does not include dambar protrusion/intrusion.
3. Controlling dimension: inches

## 44 Pin, 400 mil TSOP-II

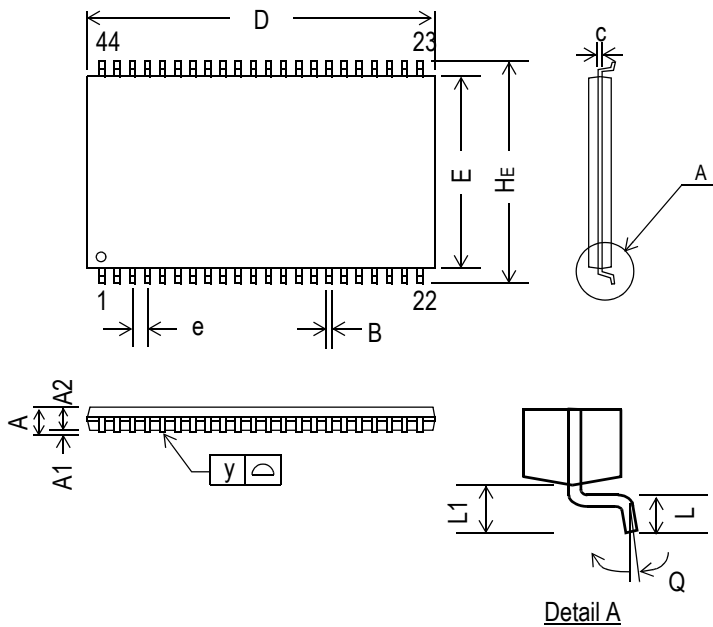

| Symbol | Dimension in inch |       |       | Dimension in mm |       |       |
|--------|-------------------|-------|-------|-----------------|-------|-------|
|        | min               | nom   | max   | min             | nom   | max   |
| A      | —                 | —     | 0.047 | —               | —     | 1.20  |
| A1     | 0.002             | —     | —     | 0.05            | —     | —     |
| A2     | 0.037             | 0.039 | 0.041 | 0.95            | 1.00  | 1.05  |
| B      | 0.01              | 0.014 | 0.018 | 0.25            | 0.35  | 0.45  |
| c      | —                 | 0.006 | —     | —               | 0.15  | —     |
| D      | 0.721             | 0.725 | 0.729 | 18.31           | 18.41 | 18.51 |
| E      | 0.396             | 0.400 | 0.404 | 10.06           | 10.16 | 10.26 |
| e      | —                 | 0.031 | —     | —               | 0.80  | —     |
| HE     | 0.455             | 0.463 | 0.471 | 11.56           | 11.76 | 11.96 |
| L      | 0.016             | 0.020 | 0.024 | 0.40            | 0.50  | 0.60  |
| L1     | —                 | 0.031 | —     | —               | 0.80  | —     |
| y      | —                 | —     | 0.004 | —               | —     | 0.10  |
| Q      | 0°                | —     | 5°    | 0°              | —     | 5°    |

**Notes:**

1. Dimension D & E do not include interlead flash.
2. Dimension B does not include dambar protrusion/intrusion.
3. Controlling dimension: mm

6 mm x 8 mm Fine Pitch BGA

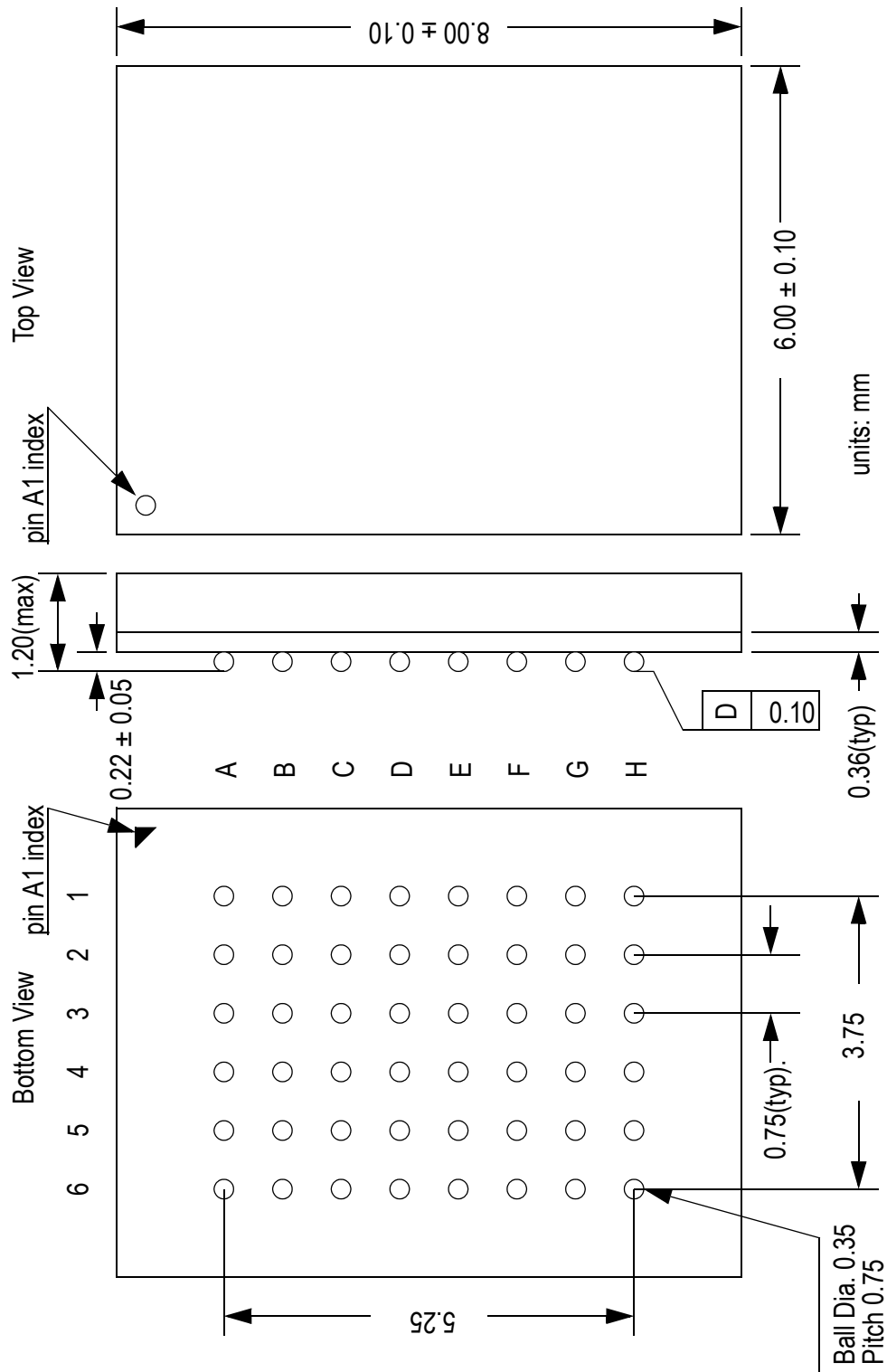

**Ordering Information**

| Part Number *  | Package                        | Access Time | Temp. Range | Status |
|----------------|--------------------------------|-------------|-------------|--------|
| GS71116ATP-7   | 400 mil TSOP-II                | 7 ns        | Commercial  | MP     |
| GS71116ATP-8   | 400 mil TSOP-II                | 8 ns        | Commercial  | MP     |
| GS71116ATP-10  | 400 mil TSOP-II                | 10 ns       | Commercial  | MP     |
| GS71116ATP-12  | 400 mil TSOP-II                | 12 ns       | Commercial  | MP     |
| GS71116ATP-7I  | 400 mil TSOP-II                | 7 ns        | Industrial  | MP     |
| GS71116ATP-8I  | 400 mil TSOP-II                | 8 ns        | Industrial  | MP     |
| GS71116ATP-10I | 400 mil TSOP-II                | 10 ns       | Industrial  | MP     |
| GS71116ATP-12I | 400 mil TSOP-II                | 12 ns       | Industrial  | MP     |
| GS71116AGP-7   | RoHS-compliant 400 mil TSOP-II | 7 ns        | Commercial  | PQ     |
| GS71116AGP-8   | RoHS-compliant 400 mil TSOP-II | 8 ns        | Commercial  | PQ     |
| GS71116AGP-10  | RoHS-compliant 400 mil TSOP-II | 10 ns       | Commercial  | PQ     |
| GS71116AGP-12  | RoHS-compliant 400 mil TSOP-II | 12 ns       | Commercial  | PQ     |
| GS71116AGP-7I  | RoHS-compliant 400 mil TSOP-II | 7 ns        | Industrial  | PQ     |
| GS71116AGP-8I  | RoHS-compliant 400 mil TSOP-II | 8 ns        | Industrial  | PQ     |
| GS71116AGP-10I | RoHS-compliant 400 mil TSOP-II | 10 ns       | Industrial  | PQ     |
| GS71116AGP-12I | RoHS-compliant 400 mil TSOP-II | 12 ns       | Industrial  | PQ     |
| GS71116AJ-7    | 400 mil SOJ                    | 7 ns        | Commercial  | MP     |
| GS71116AJ-8    | 400 mil SOJ                    | 8 ns        | Commercial  | MP     |
| GS71116AJ-10   | 400 mil SOJ                    | 10 ns       | Commercial  | MP     |
| GS71116AJ-12   | 400 mil SOJ                    | 12 ns       | Commercial  | MP     |
| GS71116AJ-7I   | 400 mil SOJ                    | 7 ns        | Industrial  | MP     |
| GS71116AJ-8I   | 400 mil SOJ                    | 8 ns        | Industrial  | MP     |
| GS71116AJ-10I  | 400 mil SOJ                    | 10 ns       | Industrial  | MP     |
| GS71116AJ-12I  | 400 mil SOJ                    | 12 ns       | Industrial  | MP     |
| GS71116AGJ-7   | RoHS-compliant 400 mil SOJ     | 7 ns        | Commercial  | PQ     |
| GS71116AGJ-8   | RoHS-compliant 400 mil SOJ     | 8 ns        | Commercial  | PQ     |
| GS71116AGJ-10  | RoHS-compliant 400 mil SOJ     | 10 ns       | Commercial  | PQ     |
| GS71116AGJ-12  | RoHS-compliant 400 mil SOJ     | 12 ns       | Commercial  | PQ     |

**Notes:**

- Customers requiring delivery in Tape and Reel should add the character "T" to the end of the part number. For example: GS71116ATP-8T.
- MP = Mass Production. PQ = Pre-Qualification.

**Ordering Information**

| Part Number *  | Package                                   | Access Time | Temp. Range | Status |
|----------------|---|-------------|-------------|--------|
| GS71116AGJ-7I  | RoHS-compliant 400 mil SOJ                | 7 ns        | Industrial  | PQ     |
| GS71116AGJ-8I  | RoHS-compliant 400 mil SOJ                | 8 ns        | Industrial  | PQ     |
| GS71116AGJ-10I | RoHS-compliant 400 mil SOJ                | 10 ns       | Industrial  | PQ     |
| GS71116AGJ-12I | RoHS-compliant 400 mil SOJ                | 12 ns       | Industrial  | PQ     |
| GS71116AU-7    | 6 mm x 8 mm Fine Pitch BGA                | 7 ns        | Commercial  | MP     |
| GS71116AU-8    | 6 mm x 8 mm Fine Pitch BGA                | 8 ns        | Commercial  | MP     |
| GS71116AU-10   | 6 mm x 8 mm Fine Pitch BGA                | 10 ns       | Commercial  | MP     |
| GS71116AU-12   | 6 mm x 8 mm Fine Pitch BGA                | 12 ns       | Commercial  | MP     |
| GS71116AU-7I   | 6 mm x 8 mm Fine Pitch BGA                | 7 ns        | Industrial  | MP     |
| GS71116AU-8I   | 6 mm x 8 mm Fine Pitch BGA                | 8 ns        | Industrial  | MP     |
| GS71116AU-10I  | 6 mm x 8 mm Fine Pitch BGA                | 10 ns       | Industrial  | MP     |
| GS71116AU-12I  | 6 mm x 8 mm Fine Pitch BGA                | 12 ns       | Industrial  | MP     |
| GS71116AGU-7   | RoHS-compliant 6 mm x 8 mm Fine Pitch BGA | 7 ns        | Commercial  | PQ     |
| GS71116AGU-8   | RoHS-compliant 6 mm x 8 mm Fine Pitch BGA | 8 ns        | Commercial  | PQ     |
| GS71116AGU-10  | RoHS-compliant 6 mm x 8 mm Fine Pitch BGA | 10 ns       | Commercial  | PQ     |
| GS71116AGU-12  | RoHS-compliant 6 mm x 8 mm Fine Pitch BGA | 12 ns       | Commercial  | PQ     |
| GS71116AGU-7I  | RoHS-compliant 6 mm x 8 mm Fine Pitch BGA | 7 ns        | Industrial  | PQ     |
| GS71116AGU-8I  | RoHS-compliant 6 mm x 8 mm Fine Pitch BGA | 8 ns        | Industrial  | PQ     |
| GS71116AGU-10I | RoHS-compliant 6 mm x 8 mm Fine Pitch BGA | 10 ns       | Industrial  | PQ     |
| GS71116AGU-12I | RoHS-compliant 6 mm x 8 mm Fine Pitch BGA | 12 ns       | Industrial  | PQ     |

**Notes:**

1. Customers requiring delivery in Tape and Reel should add the character "T" to the end of the part number. For example: GS71116ATP-8T.
2. MP = Mass Production. PQ = Pre-Qualification.

**1Mb Asynchronous Datasheet Revision History**

| Rev. Code: Old;<br>New        | Types of Changes<br>Format or Content | Page #/Revisions/Reason   |
|-------------------------------|---------------------------------------|---|
| 71116A_r1                     |                                       | • Creation of new datasheet   |
| 71116A_r1; 71116_r1_01        | Content                               | • Added 6 ns speed bin to entire document   |
| 71116A_r1_01; 71116A_r1_02    | Content                               | • Updated all power numbers<br>• Changed 6 mm x 10 mm FPBGA package designator from U to X  |
| 71116A_r1_02; 71116A_r1_03    | Content                               | • Updated Recommended Operating Conditions table on page 4<br>• Changed FPBGA package from 6 x 10 to 6 x 8 (package U)<br>• Updated Read Cycle AC Characteristics table |
| 71116A_r1_03; 71116A_r1_04    | Content                               | • Removed 6 ns speed bin from entire document<br>• Added 7 ns speed bin to entire document  |
| 71116A_r1_04;<br>71116A_r1_05 | Content                               | • Updated timings for tBHZ (Read Cycle) for 10 ns and 12 ns   |
| 71116A_r1_05;<br>71116A_r1_06 | Content/Format                        | • Updated format<br>• Added RoHS-compliant information for TSOP-II package  |
| 71116A_r1_06;<br>71116A_r1_07 | Content/Format                        | • Added RoHS-compliant information for FP-BGA package   |
| 71116A_r1_07;<br>71116A_r1_08 | Content8                              | • Added RoHS-compliant 400 mil SOJ  |

## X-ON Electronics

Largest Supplier of Electrical and Electronic Components

*Click to view similar products for [SRAM](#) category:*

*Click to view products by [GSI Technology](#) manufacturer:*

Other Similar products are found below :

[5962-8855206XA](#) [CY6116A-35DMB](#) [CY7C128A-45DMB](#) [CY7C1461KV33-133AXI](#) [CY7C199-45LMB](#) [CYDM128B16-55BVXIT](#)  
[GS8161Z36DD-200I](#) [GS88237CB-200I](#) [R1QDA7236ABB-20IB0](#) [RMLV0408EGSB-4S2#AA0](#) [IS64WV3216BLL-15CTLA3](#)  
[IS66WVE4M16ECLL-70BLI](#) [PCF8570P](#) [K6T4008C1B-GB70](#) [CY7C1353S-100AXC](#) [AS6C8016-55BIN](#) [515712X](#) [IS62WV51216EBLL-](#)  
[45BLI](#) [IS63WV1288DBLL-10HLI](#) [IS66WVE2M16ECLL-70BLI](#) [47L16-E/SN](#) [IS66WVE4M16EALL-70BLI](#) [IS62WV6416DBLL-45BLI](#)  
[IS61WV102416DBLL-10TLI](#) [CY7C1381KV33-100AXC](#) [CY7C1381KV33-100BZXI](#) [CY7C1373KV33-100AXC](#) [CY7C1381KVE33-133AXI](#)  
[CY7C4042KV13-933FCXC](#) [8602501XA](#) [5962-3829425MUA](#) [5962-8855206YA](#) [5962-8866201XA](#) [5962-8866201YA](#) [5962-8866204TA](#)  
[5962-8866206MA](#) [5962-8866207NA](#) [5962-8866208UA](#) [5962-8872502XA](#) [5962-8959836MZA](#) [5962-8959841MZA](#) [5962-9062007MXA](#)  
[5962-9161705MXA](#) [N08L63W2AB7I](#) [7130LA100PDG](#) [GS81284Z36B-250I](#) [M38510/28902BVA](#) [IS62WV12816ALL-70BLI](#) [5962-](#)  
[8971203XA](#) [5962-8971202ZA](#)