

RobuST high-temperature low-power quad voltage comparators

Datasheet - production data

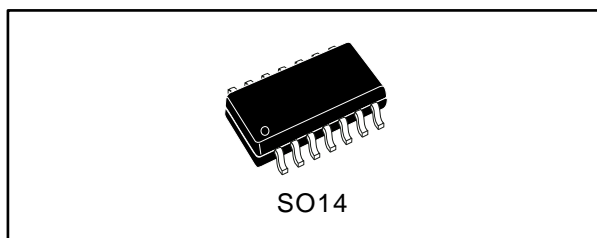

Features

- Wide single supply voltage range or dual supplies for all devices: 2 V to 36 V or ± 1 V to ± 18 V
- Very low supply current (1.1 mA) independent of supply voltage (1.4 mW/comparator at 5 V)
- Low input bias current: 25 nA typ.
- Low input offset current: ± 5 nA typ.
- Input common-mode voltage range includes ground
- Low output saturation voltage: 250 mV typ. ($I_o = 4$ mA)
- Differential input voltage range equal to the supply voltage
- TTL, DTL, ECL, MOS, CMOS compatible outputs
- Intended for use in aerospace and defense applications:
 - Dedicated traceability and part marking
 - Approval documents available for production parts
 - Adapted extended life time and obsolescence management

- Extended product change notification process
- Designed and manufactured to meet sub ppm quality goals
- Advanced mold and frame designs for superior resilience to harsh environments (acceleration, EMI, thermal, humidity)
- Extended screening capability on request
- Single fabrication, assembly, and test site
- Temperature range (-40 °C to 150 °C)

Applications

- Aerospace and defense
- Harsh environments

Description

This device consists of four independent precision voltage comparators. All comparators are designed specifically to operate from a single power supply over a wide range of voltages. Operation from split power supplies is also possible.

These comparators also have a unique characteristic in that the input common-mode voltage range includes ground even though operated from a single power supply voltage.

Contents

1	Schematic diagram.....	3
2	Package pin connections.....	4
3	Absolute maximum ratings and operating conditions	5
4	Electrical characteristics	6
5	Electrical characteristic curves	7
6	Package information	8
	6.1 SO14 package information.....	9
7	Ordering information.....	10
8	Revision history	11

1 Schematic diagram

Figure 1: Schematic diagram (1/4 RT2901H)

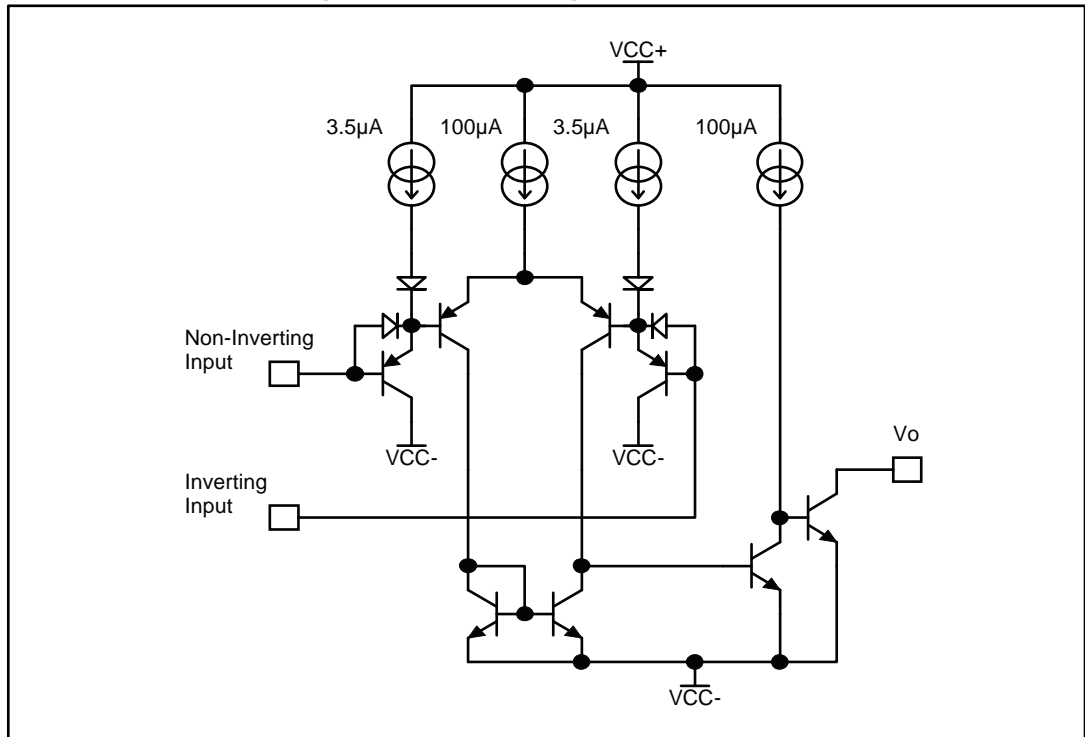

2 Package pin connections

Figure 2: Pin connections (top view)

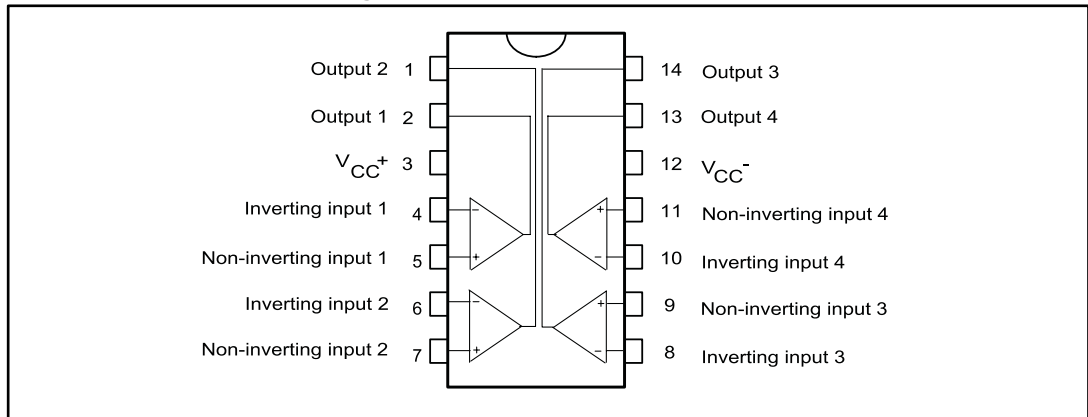

3 Absolute maximum ratings and operating conditions

Table 1: Absolute maximum ratings

Symbol	Parameter	Value	Unit
V _{CC}	Supply voltage	±18 or 36	V
V _{id}	Differential input voltage	±36	
V _{in}	Input voltage	-0.3 to 36	
	Output short-circuit duration ⁽¹⁾	20	mA
R _{thja}	Thermal resistance junction-to-ambient ⁽²⁾	105	°C/W
R _{thjc}	Thermal resistance junction-to-case ⁽²⁾	31	
T _j	Maximum junction temperature	160	°C
ESD	HBM: human body model ⁽³⁾	500	V
	MM: machine model ⁽⁴⁾	100	
	CDM: charged device model ⁽⁵⁾	1500	
T _{stg}	Storage temperature	-65 to 150	°C

Notes:

⁽¹⁾Short-circuits from the output to V_{CC}⁺ can cause excessive heating and eventual destruction. The maximum output current is approximately 20 mA, independent of the magnitude of V_{CC}⁺.

⁽²⁾Short-circuits can cause excessive heating and destructive dissipation. Values are typical.

⁽³⁾Human body model: A 100 pF capacitor is charged to the specified voltage, then discharged through a 1.5 kΩ resistor between two pins of the device. This is done for all couples of connected pin combinations while the other pins are floating.

⁽⁴⁾Machine model: A 200 pF capacitor is charged to the specified voltage, then discharged directly between two pins of the device with no external series resistor (internal resistor < 5 Ω). This is done for all couples of connected pin combinations while the other pins are floating.

⁽⁵⁾Charged device model: all pins and the package are charged together to the specified voltage and then discharged directly to the ground through only one pin. This is done for all pins.

Table 2: Operating conditions

Symbol	Parameter	Value	Unit
V _{CC} ⁺	Supply voltage	2 to 36	V
T _{oper}	Operating free air temperature range	-40 to 150	°C
V _{icm}	Input common mode voltage range (V _{CC} = 30 V) ⁽¹⁾	T _{amb} = 25 °C	0 to (V _{CC} ⁺) - 1.5
		T _{min} ≤ T _{amb} ≤ T _{max}	0 to (V _{CC} ⁺) - 2

Notes:

⁽¹⁾The input common-mode voltage of either input signal voltage should not be allowed to go negative by more than 0.3 V. The upper end of the common-mode voltage range is (V_{CC}⁺) - 1.5 V, but either or both inputs can go to 30 V without damage.

4 Electrical characteristics

Table 3: $V_{CC+} = 5\text{ V}$, $V_{CC-} = \text{ground}$, $T_{\text{amb}} = 25\text{ °C}$ (unless otherwise specified)

Symbol	Parameter	Test conditions	Min.	Typ.	Max.	Unit
V_{io}	Input offset voltage ⁽¹⁾			1	7	mV
		$T_{\text{min}} \leq T_{\text{amb}} \leq T_{\text{max}}$			15	
I_{io}	Input offset current			5	50	nA
		$T_{\text{min}} \leq T_{\text{amb}} \leq T_{\text{max}}$			150	
I_{ib}	Input bias current (I_{i+} or I_{i-}) ⁽²⁾			25	250	
		$T_{\text{min}} \leq T_{\text{amb}} \leq T_{\text{max}}$			400	
A_{vd}	Large signal voltage gain, $V_{CC} = 15\text{ V}$, $R = 15\text{ k}\Omega$, $V_o = 1\text{ to }11\text{ V}$		25	200		V/mV
I_{CC}	Supply current (all comparators)	$V_{CC} = 5\text{ V}$, no load		1.1	2	mA
		$V_{CC} = 30\text{ V}$, no load		1.3	2.5	
V_{ID}	Differential input voltage ⁽³⁾				V_{CC+}	V
V_{OL}	Low level output voltage	$V_{id} = -1\text{ V}$, $I_{\text{sink}} = 4\text{ mA}$		250	400	mV
		$T_{\text{min}} \leq T_{\text{amb}} \leq T_{\text{max}}$			700	
I_{OH}	High level output current	$V_{CC} = V_o = 30\text{ V}$, $V_{id} = 1\text{ V}$		0.1		nA
		$T_{\text{min}} \leq T_{\text{amb}} \leq T_{\text{max}}$			1	μA
I_{sink}	Output sink current	$V_{id} = -1\text{ V}$, $V_o = 1.5\text{ V}$	6	16		mA
		$T_{\text{min}} \leq T_{\text{amb}} \leq T_{\text{max}}$	2			
t_{re}	Small signal response time, $R_L = 5.1\text{ k}\Omega$ connected to V_{CC+} ⁽⁴⁾			1.3		μs
t_{rel}	Large signal response time, TTL input, $V_{\text{ref}} = 1.4\text{ V}$, $R_L = 5.1\text{ k}\Omega$ to V_{CC+} ⁽⁵⁾	Output signal at 50 % of final value			500	ns
		Output signal at 95 % of final value			1	μs

Notes:

⁽¹⁾At output switch point, $V_o \approx 1.4\text{ V}$, $R_s = 0$ with V_{CC+} from 5 V to 30 V, and over the full input common-mode range (0 V to (V_{CC+}) - 1.5 V).

⁽²⁾The direction of the input current is out of the IC due to the PNP input stage. This current is essentially constant, independent of the state of the output, so there is no load on the reference of input lines.

⁽³⁾The response time specified is for a 100 mV input step with 5 mV overdrive.

⁽⁴⁾Positive excursions of input voltage may exceed the power supply level. As long as the other voltage remains within the common-mode range, the comparator will provide a proper output state. The low input voltage state must not be less than -0.3 V (or 0.3 V below the negative power supply, if used).

⁽⁵⁾Maximum values are guaranteed by design

5 Electrical characteristic curves

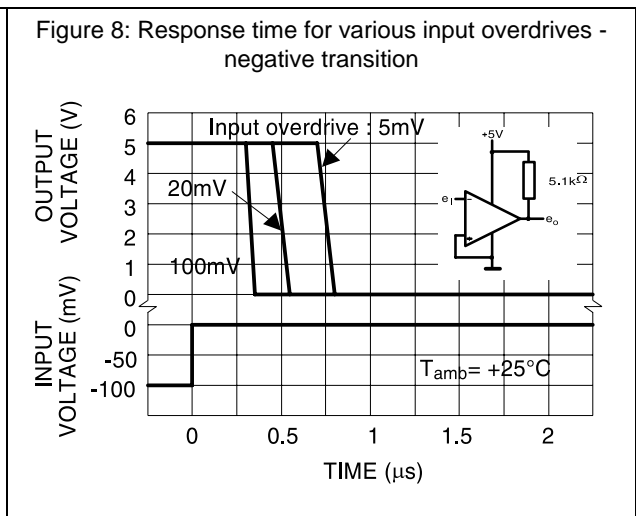
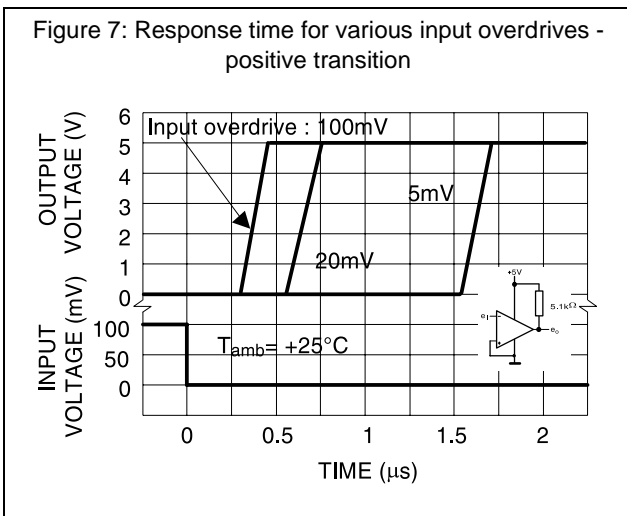
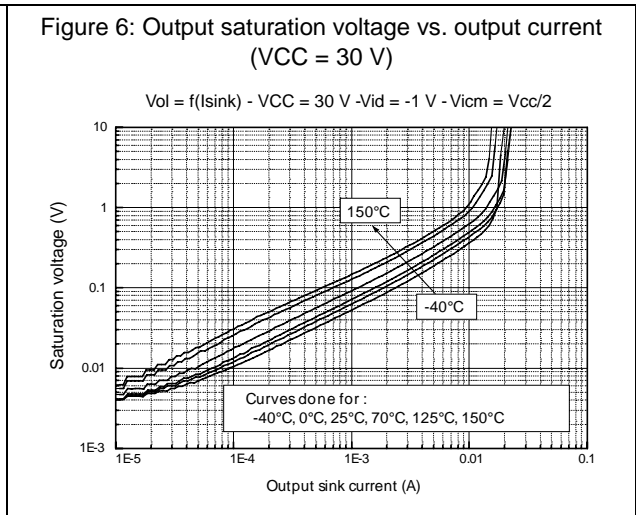
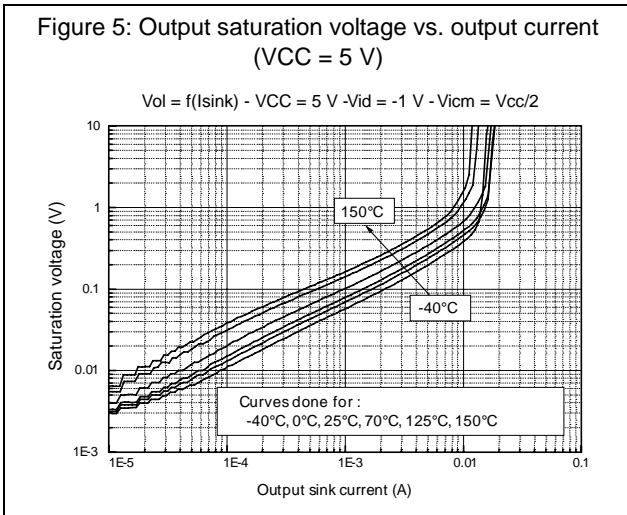
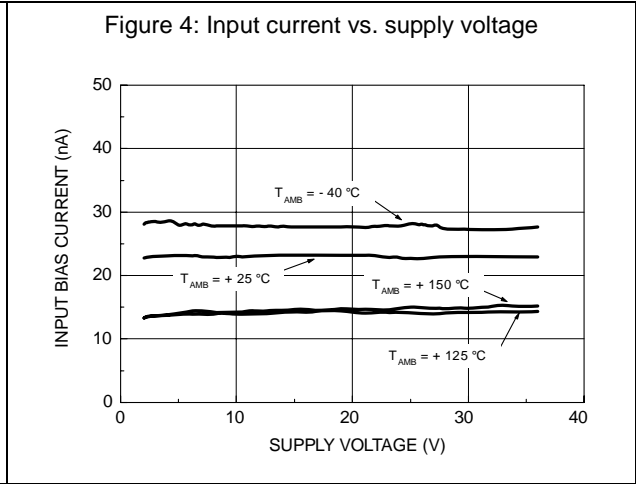
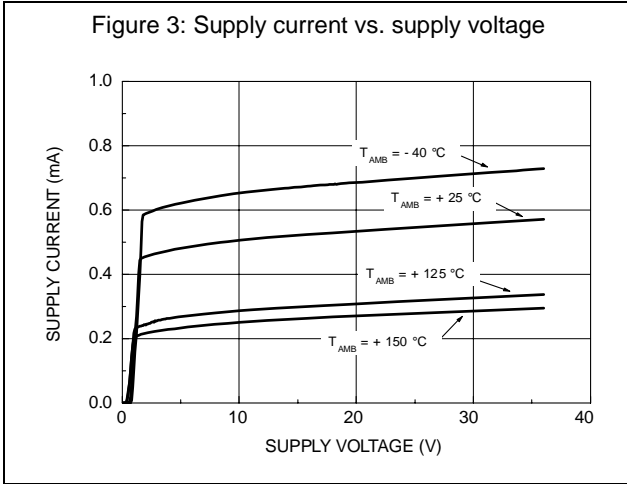

6 Package information

In order to meet environmental requirements, ST offers these devices in different grades of ECOPACK® packages, depending on their level of environmental compliance. ECOPACK® specifications, grade definitions and product status are available at: www.st.com. ECOPACK® is an ST trademark.

6.1 SO14 package information

Figure 9: SO14 package mechanical drawing

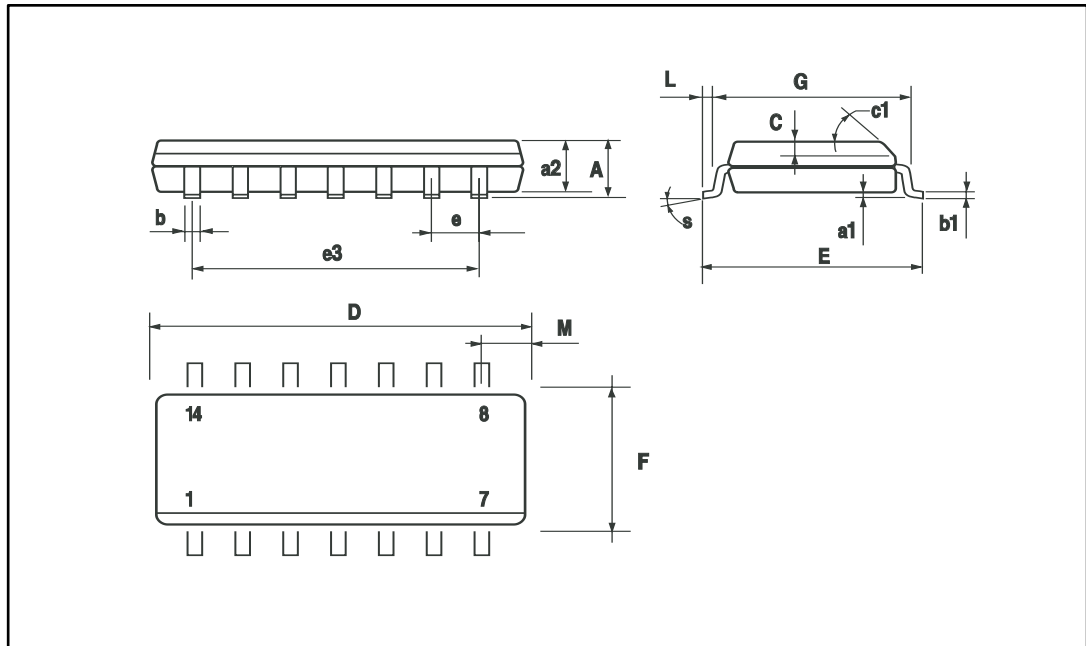

Table 4: SO14 package mechanical data

Ref	Dimensions					
	Millimeters			Inches		
	Min.	Typ.	Max.	Min.	Typ.	Max.
A			1.75			0.068
a1	0.1		0.2	0.003		0.007
a2			1.65			0.064
b	0.35		0.46	0.013		0.018
b1	0.19		0.25	0.007		0.010
C		0.5			0.019	
c1	45° (typ.)					
D	8.55		8.75	0.336		0.344
E	5.8		6.2	0.228		0.244
e		1.27			0.050	
e3		7.62			0.300	
F	3.8		4.0	0.149		0.157
G	4.6		5.3	0.181		0.208
L	0.5		1.27	0.019		0.050
M			0.68			0.026
S	8° (max.)					

7 Ordering information

Table 5: Order codes

Order code	Temperature range	Package	Packaging	Marking
RT2901HYDT	-40 °C to 150 °C	SO14	Tape and reel	R2901HY

8 Revision history

Table 6: Document revision history

Date	Revision	Changes
08-Oct-2014	1	Initial release
07-Nov-2016	2	Updated datasheet layout: silhouette, pinout, absolute maximum ratings, and electrical characteristic curves. <i>Table 2: "Operating conditions"</i> : updated the supply voltage from "2.5 to 6 V" to "2 to 36 V."

IMPORTANT NOTICE – PLEASE READ CAREFULLY

STMicroelectronics NV and its subsidiaries ("ST") reserve the right to make changes, corrections, enhancements, modifications, and improvements to ST products and/or to this document at any time without notice. Purchasers should obtain the latest relevant information on ST products before placing orders. ST products are sold pursuant to ST's terms and conditions of sale in place at the time of order acknowledgement.

Purchasers are solely responsible for the choice, selection, and use of ST products and ST assumes no liability for application assistance or the design of Purchasers' products.

No license, express or implied, to any intellectual property right is granted by ST herein.

Resale of ST products with provisions different from the information set forth herein shall void any warranty granted by ST for such product.

ST and the ST logo are trademarks of ST. All other product or service names are the property of their respective owners.

Information in this document supersedes and replaces information previously supplied in any prior versions of this document.

© 2016 STMicroelectronics – All rights reserved

X-ON Electronics

Largest Supplier of Electrical and Electronic Components

Click to view similar products for [Analog Comparators](#) category:

Click to view products by [STMicroelectronics](#) manufacturer:

Other Similar products are found below :

[633740E](#) [ADCMP396ARZ-RL7](#) [NCV2200SN2T1G](#) [NCV2200SQ2T2G](#) [SC339DR2G](#) [LM2901SNG](#) [LM339SNG](#) [AP393AM8G-13](#)
[418524AB](#) [TS393CD C3](#) [LM393SNG](#) [55122](#) [5962-8757203IA](#) [MAX971ESA+T](#) [MAX961ESAT](#) [MAX944ESD+T](#) [MAX931ESAT](#)
[MAX984CPE](#) [MAX9062EBSTG45](#) [MAX9041AEUTT](#) [MAX9022ASAT](#) [RT2902YDT](#) [M38510/11201B2A](#) [NTE911](#) [5962-8751601DA](#)
[5962-8751601CA](#) [MAX961EUA+T](#) [MAX9065EBS+TG45](#) [NCV2202SN2T1G](#) [MAX919ESA+T](#) [LT6700HS6-2#TRMPBF](#) [MAX19005CCS+](#)
[LM339EDR2G](#) [LT6700HS6-2#TRM](#) [NTE919](#) [NTE922](#) [TS883IQ2T](#) [LT6700HVCS6-3#TRMPBF](#) [LT6700HVHS6-3#TRMPBF](#)
[MAX978EEE+T](#) [MAX975ESA+T](#) [MAX9602EUG+T](#) [MAX997EUA+T](#) [MIC841NYC5-T5](#) [LM393WDT](#) [MCP6564T-E/STVAO](#)
[MAX983ESA+T](#) [NCX2200GMAZ](#) [LTC1540CMS8#PBF](#) [MC10E1651FNG](#)