

INCH-POUND

MIL-M-38510/5D
1 June 2004
SUPERSEDING
MIL-M-38510/5C
20 May 1985

MILITARY SPECIFICATION
MICROCIRCUITS, DIGITAL, TTL,
AND-OR-INVERT GATES, MONOLITHIC SILICON

Inactive for new design after 07 September 1995.

This specification is approved for use by all Departments
and Agencies of the Department of Defense.

The requirements for acquiring the product herein shall consist of this specification sheet and MIL-PRF 38535

1. SCOPE

1.1 Scope. This specification covers the detail requirements for monolithic silicon, TTL, AND-OR-INVERT logic gating microcircuits. Two product assurance classes and a choice of case outlines/lead finish are provided and are reflected in the complete part number. For this product, the requirements of MIL-M-38510 have been superseded by MIL-PRF-38535, (see 6.3).

1.2 Part or Identifying Number (PIN). The PIN is in accordance with MIL-PRF-38535, and as specified herein.

1.2.1 Device types. The device types are as follows:

<u>Device type</u>	<u>Circuit</u>
01	Expandable Dual 2-wide, 2-input AND-OR-INVERT gate
02	Dual 2-wide, 2-input AND-OR-INVERT gate
03	Expandable 4-wide, 2-input AND-OR-INVERT gate
04	4-wide, 2-input AND-OR-INVERT gate

1.2.2 Device class. The device class is the product assurance level as defined in MIL-PRF-38535.

1.2.3 Case outlines. The case outlines are as designated in MIL-STD-1835 and as follows:

<u>Outline letter</u>	<u>Descriptive designator</u>	<u>Terminals</u>	<u>Package style</u>
A	GDFP5-F14 or CDFP6-F14	14	Flat pack
B	GDFP4-F14	14	Flat pack
C	GDIP1-T14 or CDIP2-T14	14	Dual-in-line
D	GDFP1-F14 or CDFP2-F14	14	Flat pack

Comments, suggestions, or questions on this document should be addressed to: Commander, Defense Supply Center Columbus, ATTN: DSCC-VAS, 3990 East Broad St., Columbus, OH 43218-3990, or emailed to bipolar@dsc.dla.mil. Since contact information can change, you may want to verify the currency of this address information using the ASSIST Online database at www.dodssp.daps.mil.

MIL-M-38510/5D

1.3 Absolute maximum ratings.

Supply voltage range	-0.5 V dc to +7.0 V dc
Input voltage range	-1.5 V dc at -12 mA to 5.5 V dc
Storage temperature range	-65° to +150°C
Maximum power dissipation, (P _D) <u>1/</u> :	
Device type 01, 02	51 mW dc
Device type 03, 04	68 mW dc
Lead temperature (soldering, 10 seconds).....	+300°C
Thermal resistance, junction to case (θ _{JC}):	
Cases A, B, C, and D	(See MIL-STD-1835)
Junction temperature (T _J) <u>2/</u>	175°C

1.4 Recommended operating conditions.

Supply voltage (V _{CC})	4.5 V dc minimum to 5.5 V dc maximum
Minimum high-level input voltage (V _{IH})	2.0 V dc
Maximum low-level input voltage (V _{IL})	0.8 V dc
Normalized fanout (each output) <u>3/</u>	10 maximum
Case operating temperature range (T _C)	-55 °C to +125 °C

2. APPLICABLE DOCUMENTS

2.1 General. The documents listed in this section are specified in sections 3, 4, or 5 of this specification. This section does not include documents cited in other sections of this specification or recommended for additional information or as examples. While every effort has been made to ensure the completeness of this list, document users are cautioned that they must meet all specified requirements of documents cited in sections 3, 4, or 5 of this specification, whether or not they are listed.

2.2 Government documents.

2.2.1 Specifications and Standards. The following specifications and standards form a part of this specification to the extent specified herein. Unless otherwise specified, the issues of these documents are those cited in the solicitation or contract.

DEPARTMENT OF DEFENSE SPECIFICATIONS

MIL-PRF-38535 - Integrated Circuits (Microcircuits) Manufacturing, General Specification for.

DEPARTMENT OF DEFENSE STANDARDS

MIL-STD-883 - Test Method Standard for Microelectronics.
MIL-STD-1835 - Interface Standard Electronic Component Case Outlines

1/ Must withstand the added P_D due to short-circuit test (e.g., I_{OS}).
2/ Maximum junction temperature shall not be exceeded except for allowable short duration burn-in screening conditions in according with MIL-PRF-38535.
3/ The device will fanout in both high and low levels to the specified number of inputs of the same device type as that being tested.

MIL-M-38510/5D

(Copies of these documents are available online at <http://assist.daps.dla.mil/quicksearch/> or www.dodssp.daps.mil or from the Standardization Document Order Desk, 700 Robbins Avenue, Building 4D, Philadelphia, PA 19111-5094.)

2.3 Order of precedence. In the event of a conflict between the text of this specification and the references cited herein, the text of this document takes precedence. Nothing in this document, however, supersedes applicable laws and regulations unless a specific exemption has been obtained.

3. REQUIREMENTS

3.1 Qualification. Microcircuits furnished under this specification shall be products that are manufactured by a manufacturer authorized by the qualifying activity for listing on the applicable qualified manufacturers list before contract award (see 4.3 and 6.4).

3.2 Item requirements. The individual item requirements shall be in accordance with MIL-PRF-38535 and as specified herein or as modified in the device manufacturer's Quality Management (QM) plan. The modification in the QM plan shall not affect the form, fit, or function as described herein.

3.3 Design, construction, and physical dimensions. The design, construction, and physical dimensions shall be as specified in MIL-PRF-38535 and herein.

3.3.1 Terminal connections and logic diagrams. The terminal connections and logic diagrams shall be as specified on figures 1 and 2.

3.3.2 Truth tables. The truth tables and logic equations shall be as specified on figure 3.

3.3.3 Schematic circuits. The schematic circuits shall be maintained by the manufacturer and made available to the qualifying activity and the preparing activity (DSCC-VAS) upon request.

3.3.4 Case outlines. The case outlines shall be as specified in 1.2.3.

3.4 Lead material and finish. The lead material and finish shall be in accordance with MIL-PRF-38535 (see 6.6).

3.5 Electrical performance characteristics. The electrical performance characteristics are as specified in table I, and apply over the full recommended case operating temperature range, unless otherwise specified.

MIL-M-38510/5D

TABLE I. Electrical performance characteristics.

Test	Symbol	Conditions -55°C ≤ T _C ≤ +125°C	Limits		
			Min	Max	Units
High-level output voltage	V _{OH}	V _{CC} = 4.5 V I _{OH} = -400 μA <u>1/</u> V _{IN} = 0.8 V <u>01, 02, 04</u> V _{IN} = 0.7 V <u>03</u>	2.4	----	V
Low-level output voltage	V _{OL}	V _{CC} = 4.5 V, I _{OL} = 16 mA V _{IN} = 2.0 V for all inputs of gate under test <u>1/</u>		0.4	V
Input clamp voltage	V _{IC}	V _{CC} = 4.5 V, I _{IN} = -12 mA T _C = 25°C		-1.5	V
High-level input current	I _{IH1}	V _{CC} = 5.5 V, V _{IN} = 2.4 V <u>2/</u>		40	μA
High-level input current	I _{IH2}	V _{CC} = 5.5 V, V _{IN} = 5.5 V <u>2/</u>		100	μA
Low-level input current	I _{IL}	V _{CC} = 5.5 V, V _{IN} = 0.4 V <u>1/</u>	-0.7	-1.6	mA
Short-circuit output current	I _{OS}	V _{CC} = 5.5 V <u>2/ 3/</u>	-20	-55	mA
High-level supply current	I _{CCH}	V _{CC} = 5.5 V <u>2/</u> V _{IN} = 0 V		7.2	mA
Low-level supply current	I _{CCL}	V _{CC} = 5.5 V <u>1/</u> <u>01, 02,</u> V _{IN} = 5.5 V <u>03, 04</u>		14 9.5	mA mA
Propagation delay time, high-to-low level	t _{PHL}	C _L = 50 pF, R _L = 390 Ω	3	24	ns
Propagation delay time low-to-high level	t _{PLH}	C _L = 50 pF, R _L = 390 Ω	3	30	ns
Expander current Types 01 and 03	I _X	V _X = 0.4 V, I _{OL} = 16 mA	----	2.9	mA
Base emitter voltage	V _{BE}	I _X = 0.41 mA I _{OL} = 16 mA	----	1.1	V

1/ All unspecified inputs at 5.5 volts.2/ All unspecified inputs grounded.3/ Not more than one output should be shorted at a time.

3.6 Electrical test requirements. The electrical test requirements for each device class shall be the subgroups specified in table II. The electrical tests for each subgroup are described in table III.

TABLE II. Electrical test requirements.

MIL-STD-883 test requirements	Subgroups (see table III)	
	Class S devices	Class B devices
Interim electrical parameters	1	1
Final electrical test parameters	1*, 2, 3, 9	1*, 2, 3, 9
Group A test requirements	1, 2, 3, 9 10, 11	1, 2, 3, 9 10, 11
Group B test when using method 5005 QCI option	1, 2, 3, 9 10, 11	N/A
Groups C end-point electrical parameters	1, 2, 3, 9,10,11	1, 2, 3
Groups D end-point electrical parameters	1, 2, 3	1, 2, 3

*PDA applies to subgroup 1.

3.7 Marking. Marking shall be in accordance with MIL-PRF-38535.

3.8 Microcircuit group assignment. The devices covered by this specification shall be in microcircuit group number 10 (see MIL-PRF-38535, appendix A).

4. VERIFICATION

4.1 Sampling and inspection. Sampling and inspection procedures shall be in accordance with MIL-PRF-38535 or as modified in the device manufacturer's Quality Management (QM) plan. The modification in the QM plan shall not effect the form, fit, or function as described herein.

4.2 Screening. Screening shall be in accordance with MIL-PRF-38535 and shall be conducted on all devices prior to qualification and quality conformance inspection. The following additional criteria shall apply:

- a. The burn-in test duration, test condition, and test temperature, or approved alternatives shall be as specified in the device manufacturer's QM plan in accordance with MIL-PRF-38535. The burn-in test circuit shall be maintained under document control by the device manufacturer's Technology Review Board (TRB) in accordance with MIL-PRF-38535 and shall be made available to the acquiring or preparing activity upon request. The test circuit shall specify the inputs, outputs, biases, and power dissipation, as applicable, in accordance with the intent specified in test method 1015 of MIL-STD-883.
- b. Interim and final electrical test parameters shall be as specified in table II, except interim electrical parameters test prior to burn-in is optional at the discretion of the manufacturer.
- c. Additional screening for space level product shall be as specified in MIL-PRF-38535, appendix B.

4.3 Qualification inspection. Qualification inspection shall be in accordance with MIL-PRF-38535.

4.4 Technology Conformance inspection (TCI). Technology conformance inspection shall be in accordance with MIL-PRF-38535 and herein for groups A, B, C, and D inspections (see 4.4.1 through 4.4.4).

MIL-M-38510/5D

4.4.1 Group A inspection. Group A inspection shall be in accordance with table III of MIL-PRF-38535 and as follows:

- a. Tests shall be as specified in table II herein.
- b. Subgroups 4, 5, 6, 7, and 8 shall be omitted.

4.4.2 Group B inspection. Group B inspection shall be in accordance with table II MIL-PRF-38535.

4.4.3 Group C and D inspection. Group C and D inspection shall be in accordance with table IV and V of MIL-PRF-38535 and as follows:

- a. End-point electrical parameters shall be as specified in table II herein.
- b. The steady-state life test duration, test condition, and test temperature, or approved alternatives shall be as specified in the device manufacturer's QM plan in accordance with MIL-PRF-38535. The burn-in test circuit shall be maintained under document control by the device manufacturer's Technology Review Board (TRB) in accordance with MIL-PRF-38535 and shall be made available to the acquiring or preparing activity upon request. The test circuit shall specify the inputs, outputs, biases, and power dissipation, as applicable, in accordance with the intent specified in test method 1005 of MIL-STD-883.

4.5 Methods of inspection. Methods of inspection shall be as specified and as follows:

4.5.1 Voltage and current. All voltages given are referenced to the microcircuit ground terminal. Currents given are conventional and positive when flowing into the referenced terminal.

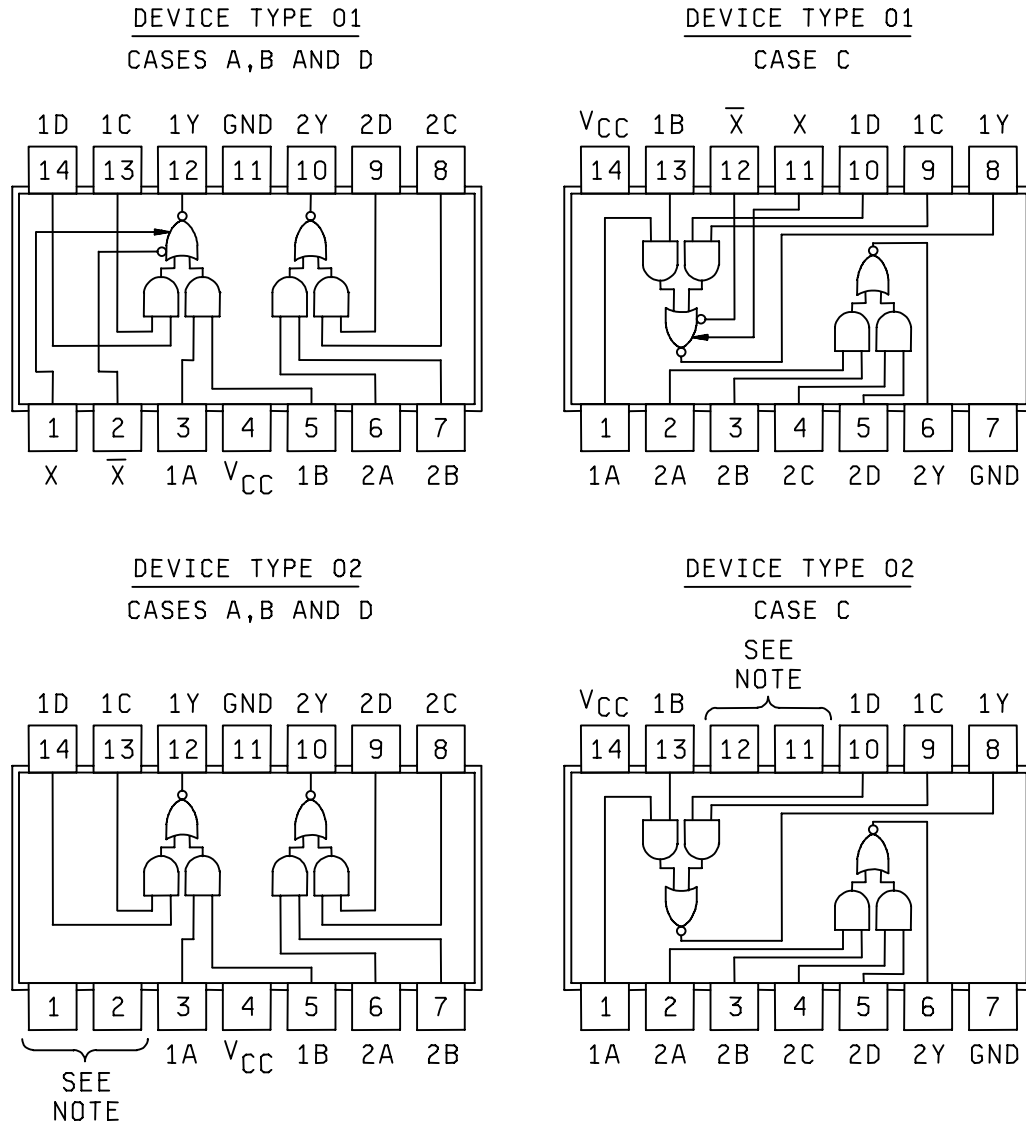

NOTE: Do not use as external tie points since they may be electrically connected internally.

FIGURE 1. Logic diagram and terminal connections (top views).

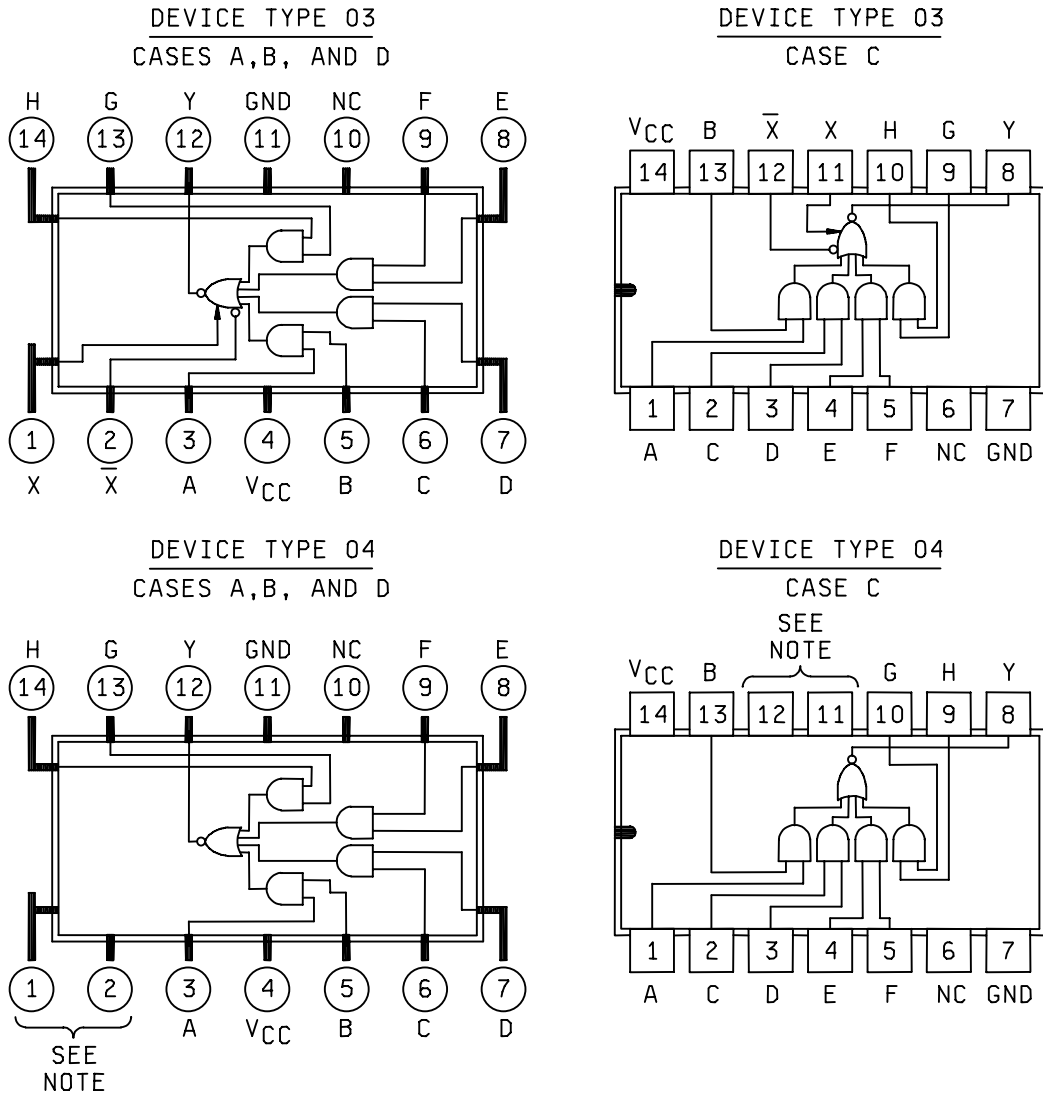

NOTE: Do not use as external tie points since they may be electrically connected internally.

FIGURE 1. Logic diagram and terminal connections (top views) – Continued.

Device Type 01

TRUTH TABLE (each gate)					
Input					Output
A	B	C	D	X	Y
H	H	*	*	*	L
*	*	H	H	*	L
*	*	*	*	H	L

* Either H or L

All other combinations of H and L at the input give H output.

Positive Logic: $Y = \overline{(AB) + (CD) + (X)}$

Device Type 02

TRUTH TABLE (each gate)					
Input					Output
A	B	C	D		Y
H	H	*	*		L
*	*	H	H		L

* Either H or L - All other combinations of H and L at the input give H output.

Positive Logic: $Y = \overline{(AB) + (CD)}$

Figure 2. Truth tables and logic equations.

MIL-M-38510/5D

Device Type 03

Input									Output
A	B	C	D	E	F	G	H	X	Y
H	H	*	*	*	*	*	*	*	L
*	*	H	H	*	*	*	*	*	L
*	*	*	*	H	H	*	*	*	L
*	*	*	*	*	*	H	H	*	L
*	*	*	*	*	*	*	*	H	L

* Either H or L - All other combinations of H and L at the input give H output.

Positive logic: $Y = \overline{(AB) + (CD) + (EF) + (GH) + X}$

Device Type 04

Input								Output
A	B	C	D	E	F	G	H	Y
H	H	*	*	*	*	*	*	L
*	*	H	H	*	*	*	*	L
*	*	*	*	H	H	*	*	L
*	*	*	*	*	*	H	H	L

* Either H or L - All other combinations of H and L at the input give H output.

Positive logic: $Y = \overline{(AB) + (CD) + (EF) + (GH)}$

FIGURE 2. Truth tables and logic equations – Continued.

TABLE III. Group A inspection for device type 01.
Terminal conditions (High ≥ 2.0 V, Low ≤ 0.8 V or open)

Subgroup	Symbol	MIL-STD-883 method	Cases A,B,D		1	2	3	4	5	6	7	8	9	10	11	12	13	14
			Case C	11	12	1	14	13	2	3	4	5	6	7	8	9	10	
			Test no.	X	\bar{X}	1A	V _{CC}	1B	2A	2B	2C	2D	2Y	GND	1Y	1C	1D	
1 T _C = +25°C	V _{OH}	3006	1			.8 V	4.5 V	4.5 V						GND	-.4 mA	GND	GND	
	"	"	2			4.5 V	"	.8 V						"	"	GND	GND	
	"	"	3			GND	"	GND						"	"	.8 V	4.5 V	
	"	"	4			"	"	"						"	"	4.5 V	.8 V	
	"	"	5 1/	.15 mA	-.15 mA	"	"	"						"	"	GND	GND	
	"	"	5a 2/	0.4 V	-.15 mA	"	"	"						"	"	GND	GND	
	"	"	6			"	"		.8 V	4.5 V	GND	GND	-.4 mA	"	"			
	"	"	7			"	"		4.5 V	.8 V	GND	GND	"	"	"			
	"	"	8			"	"		GND	GND	.8 V	4.5 V	"	"	"			
	"	"	9			"	"		GND	GND	4.5 V	.8 V	"	"	"			
	"	V _{OL}	3007	10			2 V	"	2 V					"	16 mA	GND	GND	
	"	"	"	11			GND	"	GND					"	16 mA	2 V	2 V	
	"	"	"	12	.3 mA	+	GND	"	GND					"	16 mA	GND	GND	
	"	"	"	12a 3/	2.5 mA	1.0 V	GND	"	GND					"	16 mA	GND	GND	
	"	"	"	13			"	"		2 V	2 V	GND	GND	16 mA	"			
	"	"	"	14			"	"		GND	GND	2 V	2 V	16 mA	"			
	"	I _{IL}	3009	15			.4 V	5.5 V	4.5 V						"			
	"	"	"	16			4.5 V	"	.4 V						"			
	"	"	"	17			"	"		.4 V	4.5 V				"			
	"	"	"	18			"	"		4.5 V	.4 V				"			
	"	"	"	19			"	"				.4 V	4.5 V		"			
	"	"	"	20			"	"				4.5 V	.4 V		"			
	"	"	"	21			"	"							"		.4 V	4.5 V
	"	"	"	22			"	"							"		4.5 V	.4 V
	"	I _{IH1}	3010	23			2.4 V	"	GND						"			
	"	"	"	24			GND	"	2.4 V						"			
	"	"	"	25			"	"		2.4 V	GND				"			
	"	"	"	26			"	"		GND	2.4 V				"			
	"	"	"	27			"	"				2.4 V	GND		"			
	"	"	"	28			"	"				GND	2.4 V		"			
"	"	"	29			"	"							"		2.4 V	GND	
"	"	"	30			"	"							"		GND	2.4 V	

NOTES:

R₁ = 138 between X and \bar{X} .

1/ At the manufacturer's option, the high level output voltage for the expanded inputs may be verified by use of an alternate equivalent procedure. The procedure is to omit the -400 μ A current source on Y output and connect a 6K \pm 1% ohm resistor in parallel with V_{OH} voltmeter between the output pin and ground. The V_{OH} minimum limit is met if the resultant voltage drop is greater than 2.4 V.

2/ The high level output voltage test for the expander input may be verified by performing either test 5 or 5a.

3/ The low level output voltage test for the expander input may be verified by performing either test 12 or 12a.

TABLE III. Group A inspection for device type 01. - Continued
Terminal conditions (High ≥ 2.0 V, Low ≤ 0.8 V or open).

Subgroup	Symbol	MIL-STD-883 method	Cases A, B, D	1	2	3	4	5	6	7	8	9	10	11	12	13	14	Measurement terminal	
			Case C	11	12	1	14	13	2	3	4	5	6	7	8	9	10		
			Test no.	X	\bar{X}	1A	V _{CC}	1B	2A	2B	2C	2D	2Y	GND	1Y	1C	1D		
1 T _C = +25°C	I _{IH2}	3010	31			5.5 V	5.5 V	GND						GND				1A	
	"	"	32			GND	"	5.5 V						"				1B	
	"	"	33				"		5.5 V	GND				"				2A	
	"	"	34				"		GND	5.5 V				"				2B	
	"	"	35				"			5.5 V	GND			"				2C	
	"	"	36				"				5.5 V	GND		"				2D	
	"	"	37				"				GND	5.5 V		"		5.5 V	GND	1C	
	"	"	38				"							"	GND	5.5 V		1D	
	"	I _{OS}	3011	39			GND	"	GND						"	GND	GND	GND	1Y
	"	I _{OS}	3011	40				"		GND	GND	GND	GND	GND	"				2Y
	"	I _{CCL}	3005	41			5.5 V	"	5.5 V	5.5 V	5.5 V	5.5 V	5.5 V		"		5.5 V	5.5 V	V _{CC}
	"	I _{CCH}	3005	42			GND	"	GND	GND	GND	GND	GND		"		GND	GND	V _{CC}
	"	V _{IC}		43			-12 mA	4.5 V							"				1A
	"	"		44				"	-12 mA						"				1B
	"	"		45				"							"		-12 mA		1C
	"	"		46				"							"			-12 mA	1D
	"	"		47				"		-12 mA					"				2A
"	"		48				"			-12 mA				"				2B	
"	"		49				"				-12 mA			"				2C	
"	"		50				"					-12 mA		"				2D	
"	I _X	3/	51	-0.4 V	1/	GND	"	GND	GND	GND	GND			"	16 mA	GND	GND	\bar{X}	
"	I _X	3/	51a		1.4 V	"	"	"	"	"	"			"	16 mA	"	"	\bar{X}	
"	V _X	3/	51b	1.7 mA	0.8 V	"	"	"	"	"	"			"	16 mA	"	"	X	
"	V _{BE}	2/	52	.41 mA		"	"	"	"	"	"			"	16 mA	"	"	X	
2	Same tests, terminal conditions and limits as for subgroup 1, except T _C = +125°C and V _{IC} tests are omitted.																		
3	Same tests, terminal conditions and limits as for subgroup 1, except T _C = -55°C and V _{IC} tests are omitted.																		
9	t _{PHL}	3003 (Fig 3)	53			IN	5.0 V	2.4 V	GND	GND	GND	GND	GND	GND	OUT	GND	GND	1A to 2A to	
	t _{PLH}	"	54			GND	"	GND	IN	IN	2.4 V	"	"	"	"	"	"	2A to	
10 T _C = +125°C	t _{PHL}	"	55			IN	"	2.4 V	GND	GND	GND	"	"	"	OUT	"	OUT	"	1A to 2A to
			56			GND	"	GND	IN	IN	2.4 V	"	"	"	"	"	"	"	2A to
	t _{PLH}	"	57			IN	"	2.4 V	GND	GND	GND	"	"	"	OUT	"	OUT	"	1A to 2A to
			58			GND	"	GND	IN	IN	2.4 V	"	"	"	"	"	"	"	2A to
59			IN	"	2.4 V	GND	GND	GND	GND	"	"	"	OUT	"	OUT	"	1A to 2A to		
60			GND	"	GND	IN	IN	2.4 V	"	"	"	"	OUT	"	"	"	"	2A to	
11	Same tests, terminal conditions and limits as for subgroup 10, except T _C = -55°C.																		

NOTES: 1/ -0.4 V at X referenced to \bar{X} (see figure 4).

2/ X and \bar{X} shorted (see figure 5).

3/ At the manufacturer's option, the expander current test may be verified by performing either 51 or 51a and 51b.

TABLE III. Group A inspection for device type 02.
Terminal conditions (High ≥ 2.0 V, Low ≤ 0.8 V or open)

Subgroup	Symbol	MIL-STD-883 method	Cases A, B, D	1	2	3	4	5	6	7	8	9	10	11	12	13	14	Measured terminal	
			Case C	11	12	1	14	13	2	3	4	5	6	7	8	9	10		
			Test no.	NC	NC	1A	V _{CC}	1B	2A	2B	2C	2D	2Y	GND	1Y	1C	1D		
1 T _C = +25°C	V _{OH}	3006	1			.8 V	4.5 V	4.5 V						GND	-.4 mA	GND	GND	1Y	
	"	"	2			4.5 V	"	.8 V						"	"	GND	GND	1Y	
	"	"	3			GND	"	GND						"	"	.8 V	4.5 V	1Y	
	"	"	4			GND	"	GND						"	"	4.5 V	.8 V	1Y	
	"	"	5				"		.8 V	4.5 V	GND	GND	-.4 mA	"				2Y	
	"	"	6				"		4.5 V	.8 V	GND	GND	"	"				2Y	
	"	"	7				"		GND	GND	.8 V	4.5 V	"	"				2Y	
	"	"	8				"		GND	GND	4.5 V	.8 V	"	"				2Y	
	"	V _{OL}	3007	9			2 V	"	2 V					"	16 mA	GND	GND	1Y	
	"	"	"	10			GND	"	GND					"	16 mA	2 V	2 V	1Y	
	"	"	"	11				"		2 V	2 V	GND	GND	16 mA				2Y	
	"	"	"	12				"		GND	GND	2 V	2 V	16 mA				2Y	
	"	I _{IL}	3009	13			.4 V	5.5 V	4.5 V					"					1A
	"	"	"	14			4.5 V	"	.4 V					"					1B
	"	"	"	15				"		.4 V	4.5 V			"					2A
	"	"	"	16				"		4.5 V	.4 V			"					2B
	"	"	"	17				"				.4 V	4.5 V	"					2C
	"	"	"	18				"				4.5 V	.4 V	"					2D
	"	"	"	19				"						"		.4 V	4.5 V		1C
	"	"	"	20				"						"		4.5 V	.4 V		1D
	"	I _{IH1}	3010	21			2.4 V	"	GND					"					1A
	"	"	"	22			GND	"	2.4 V					"					1B
	"	"	"	23				"		2.4 V	GND			"					2A
	"	"	"	24				"		GND	2.4 V			"					2B
	"	"	"	25				"				2.4 V	GND	"					2C
	"	"	"	26				"				GND	2.4 V	"					2D
	"	"	"	27				"						"			2.4 V	GND	1C
	"	"	"	28				"						"		GND	2.4 V		1D
	"	I _{IH2}	"	29			5.5 V	"	GND					"					1A
	"	"	"	30			GND	"	5.5 V					"					1B
	"	"	"	31				"		5.5 V	GND			"					2A
	"	"	"	32				"		GND	5.5 V			"					2B
	"	"	"	33				"				5.5 V	GND	"					2C
	"	"	"	34				"				GND	5.5 V	"					2D
	"	"	"	35				"						"		5.5 V	GND		1C
	"	"	"	36				"						"		GND	5.5 V		1D

TABLE III. Group A inspection for device type 02. Continued
Terminal conditions (pins not designated may be $H \geq 2.0$ V or $L \leq 0.8$ V or open).

Subgroup	Symbol	MIL-STD-883 method	Cases A,B,D	1	2	3	4	5	6	7	8	9	10	11	12	13	14	Mea term	
			Case C	11	12	1	14	13	2	3	4	5	6	7	8	9	10		
			Test no.	NC	NC	1A	V _{CC}	1B	2A	2B	2C	2D	2Y	GND	1Y	1C	1D		
1 T _C = +25°C	I _{OS}	3011	37			GND	5.5 V	GND						GND	GND	GND	GND	1	
	I _{OS}	3011	38				"		GND	GND	GND	GND	GND	"				2	
	I _{CCL}	3005	39			5.5 V	"	5.5 V	5.5 V	5.5 V	5.5 V	5.5 V		"		5.5 V	5.5 V	V	
	I _{CCH}	3005	40			GND	"	GND	GND	GND	GND	GND		"		GND	GND	V	
	V _{IC}		41			-12 mA	4.5 V							"				1	
	"		42				"	-12 mA						"				1	
	"		43				"							"		-12 mA		1	
	"		44				"							"			12 mA	1	
	"		45				"			-12 mA				"					2
	"		46				"				-12 mA			"					2
	"		47				"					-12 mA		"					2
"		48				"						-12 mA	"					2	
2	Same tests, terminal conditions and limits as for subgroup 1, except T _C = +125°C and V _{IC} tests are omitted.																		
3	Same tests, terminal conditions and limits as for subgroup 1, except T _C = -55°C and V _{IC} tests are omitted.																		
9	t _{PHL}	3003 (Fig 3)	49			IN	5.0 V	2.4 V	GND	GND	GND	GND		GND	OUT	GND	GND	1A	
	50				GND	"	GND	IN	2.4 V	"	"	OUT		"	"	"	"	2A	
t _{PLH}	"	51			IN	"	2.4 V	GND	GND	"	"		"	OUT	"	"	"	1A	
		52			GND	"	GND	IN	2.4 V	"	"	OUT	"	"	"	"	"	2A	
10 T _C = +125°C	t _{PHL}	"	53			IN	"	2.4 V	GND	GND	"	"		"	OUT	"	"	1A	
	54				GND	"	GND	IN	2.4 V	"	"	OUT	"	"	"	"	"	2A	
t _{PLH}	"	55			IN	"	2.4 V	GND	GND	"	"		"	OUT	"	"	"	1A	
		56			GND	"	GND	IN	2.4 V	"	"	OUT	"	"	"	"	"	2A	
11	Same tests, terminal conditions and limits as for subgroup 10, except T _C = -55°C.																		

TABLE III. Group A inspection for device type 03.
Terminal conditions (High ≥ 2.0 V, Low ≤ 0.7 V or open)

Subgroup	Symbol	MIL-STD-883 method	Cases A,B,D	1	2	3	4	5	6	7	8	9	10	11	12	13	14	Meas. terminal		
			Case C	11	12	1	14	13	2	3	4	5	6	7	8	9	10			
			Test no.	X	\bar{X}	A	V _{CC}	B	C	D	E	F	NC	GND	Y	G	H			
1 T _C = 25°C	V _{OH}	3006	1			0.7 V	4.5 V	4.5 V	0.7 V	4.5 V	0.7 V	4.5 V		GND	-4 mA	0.7 V	4.5 V	Y		
	"	"	2			4.5 V	"	0.7 V	4.5 V	0.7 V	4.5 V	0.7 V		"	"	4.5 V	0.7 V	"		
	"	"	3 1/	.15 mA	-.15 mA	GND	"	GND	GND	GND	GND	GND		"	"	GND	GND	"		
	"	"	3a 2/	0.4 V	-.15 mA	GND	"	GND	GND	GND	GND	GND		"	"	GND	GND	"		
"	V _{OL}	3007	4			2 V	"	2 V	GND	GND	GND	GND		"	16 mA	GND	GND	"		
	"	"	5			GND	"	GND	2 V	2 V	GND	GND		"	"	GND	GND	"		
	"	"	6			"	"	"	GND	GND	2 V	2 V		"	"	GND	GND	"		
	"	"	7			"	"	"	"	"	GND	GND		"	"	2.0 V	2.0 V	"		
	"	"	8	.3 mA	3/	"	"	"	"	"	GND	GND		"	"	GND	GND	"		
"	"	"	8a 4/	2.5 mA	1.0 V	"	"	"	"	"	GND	GND		"	"	GND	GND	"		
"	I _{IL}	3009	9			0.4 V	5.5 V	4.5 V						"				A		
			10			4.5 V	"	0.4 V						"				B		
			11				"			0.4 V	4.5 V				"				C	
			12				"			4.5 V	0.4 V				"				D	
			13				"					0.4 V	4.5 V		"				E	
			14				"							0.4 V	4.5 V					F
			15				"									"		0.4 V	4.5 V	G
			16				"									"		4.5 V	0.4 V	H
"	I _{IH1}	3010	17			2.4 V	"	GND						"				A		
			18			GND	"	2.4 V						"					B	
			19				"			2.4 V	GND				"					C
			20				"			GND	2.4 V				"					D
			21				"					2.4 V	GND		"					E
			22				"						GND	2.4 V		"				F
			23				"									"		2.4 V	GND	G
			24				"									"		GND	2.4 V	H
"	I _{IH2}	3010	25			5.5 V	"	GND						"				A		
			26			GND	"	5.5 V						"					B	
			27				"			5.5 V	GND				"					C
			28				"			GND	5.5 V				"					D
			29				"					5.5 V	GND		"					E
			30				"						5.5 V	GND		"				F
			31				"									"		5.5 V	GND	G
			32				"									"		GND	5.5 V	H
"	I _{OS}	3011	33			GND	"	GND	GND	GND	GND	GND		"	GND	GND	GND	Y		
	I _{OCL}	3005	34			5.5 V	"	5.5 V	5.5 V	5.5 V	5.5 V	5.5 V		"		5.5 V	5.5 V	V _{CC}		
	I _{OCH}	3005	35			GND	"	GND	GND	GND	GND	GND		"		GND	GND	V _{CC}		

1/ At the manufacturer's option, the high level output voltage for the expanded inputs may be verified by use of an alternate equivalent procedure. The procedure is to omit the -400 μ A current source on Y output and connect a 6K \pm 1% ohm resistor in parallel with V_{OH} voltmeter between the output pin and ground. The V_{OH} minimum limit is met if the resultant voltage drop is greater than 2.4 V.

2/ The high level output voltage test for the expander input may be verified by performing either test 3 or 3a.

3/ R₁ = 138 Ω between X and \bar{X} .

4/ The low level output voltage test for the expander input may be verified by performing either test 8 or 8a.

TABLE III. Group A inspection for device type 03, - Continued
Terminal conditions (High ≥ 2.0 V, Low ≤ 0.7 V or open).

Subgroup	Symbol	MIL-STD-883 method	Cases A,B,D	1	2	3	4	5	6	7	8	9	10	11	12	13	14	Meas. termin.
			Case C	11	12	1	14	13	2	3	4	5	6	7	8	9	10	
			Test no.	X	\bar{X}	A	V_{CC}	B	C	D	E	F	NC	GND	Y	G	H	
$T_C = +25^\circ\text{C}$	V_{IC}	3005	36			-12 mA	4.5 V								GND			A
"	"		37				"	-12 mA							"			B
"	"		38				"		-12 mA						"			C
"	"		39				"			-12 mA					"			D
"	"		40				"				-12 mA				"			E
"	"		41				"					-12 mA			"			F
"	"		42				"								"		-12 mA	G
"	"		43				"								"		-12 MA	H
"	I_X	3/	44	-4 V	1/	GND	"	GND	GND	GND	GND	GND		"	16 mA	GND	GND	\bar{X}
"	I_X	3/	44a		1.4 V	"	"	"	"	"	"	"		"	"	"	"	\bar{X}
"	V_X	3/	44b	1.7 mA	0.8 V	"	"	"	"	"	"	"		"	"	"	"	X
"	V_{BE}		45	.41 mA	2/	"	"	"	"	"	"	"		"	"	"	"	X
2	Same tests, terminal conditions and limits as for subgroup 1, except $T_C = +125^\circ\text{C}$ and V_{IC} tests are omitted.																	
3	Same tests, terminal conditions and limits as for subgroup 1, except $T_C = -55^\circ\text{C}$ and V_{IC} tests are omitted.																	
9	t_{PHL}	.3003 (Fig 3)	46			IN	5.0 V	2.4 V	GND	GND	GND	GND		GND	OUT	GND	GND	A to Y
	t_{PLH}	"	47			"	"	"	"	"	"	"		"	"	"	"	A to Y
10 $T_C = +125^\circ\text{C}$	t_{PHL}	"	48			"	"	"	"	"	"	"		"	"	"	"	A to Y
	t_{PLH}	"	49			"	"	"	"	"	"	"		"	"	"	"	A to Y
11	Same tests, terminal conditions and limits as for subgroup 10, except $T_C = -55^\circ\text{C}$.																	

1/ -4 V at X referenced to \bar{X} (see figure 4).

2/ x and \bar{X} shorted (see figure 5).

3/ At the manufacturer's option, the expander current test may be verified by performing 44 or 44a and 44b.

TABLE III. Group A inspection for device type 04.
Terminal conditions (High ≥ 2.0 V, Low ≤ 0.8 V or open)

Subgroup	Symbol	MIL-STD-883 method	Cases A,B,D	1	2	3	4	5	6	7	8	9	10	11	12	13	14	Meas. terminal
			Case C	11	12	1	14	13	2	3	4	5	6	7	8	9	10	
			Test No.	NC	NC	A	V _{CC}	B	C	D	E	F	NC	GND	Y	G	H	
1	V _{OH}	3006	1			.8 V	4.5 V	4.5 V	.8 V	4.5 V	.8 V	4.5 V		GND	-4 mA	.8 V	4.5 v	Y
"	V _{OH}	3006	2			4.5 V	"	.8 V	4.5 V	.8 V	4.5 V	.8 V		"	-4 mA	4.5 V	.8 V	Y
"	V _{OL}	3007	3			2 V	"	2 V	GND	GND	GND	GND		"	16 mA	GND	GND	Y
"	"	"	4			GND	"	GND	2 V	2 V	GND	GND		"	"	GND	GND	Y
"	"	"	5			"	"	"	GND	GND	2 V	2 V		"	"	GND	GND	Y
"	"	"	6			"	"	"	GND	GND	GND	GND		"	"	2 V	2 V	Y
"	I _{IL}	3009	7			.4 V	5.5 V	4.5 V						"				A
"	"	"	8			4.5 V	"	.4 V						"				B
"	"	"	9			"	"		.4 V	4.5 V				"				C
"	"	"	10			"	"		4.5 V	.4 V				"				D
"	"	"	11			"	"				.4 V	4.5 V		"				E
"	"	"	12			"	"				4.5 V	.4 V		"				F
"	"	"	13			"	"							"		.4 V	4.5 V	G
"	"	"	14			"	"							"		4.5 V	.4 V	H
"	I _{BH1}	3010	15			2.4 V	"	GND						"				A
"	"	"	16			GND	"	2.4 V						"				B
"	"	"	17			"	"		2.4 V	GND				"				C
"	"	"	18			"	"		GND	2.4 V				"				D
"	"	"	19			"	"				2.4 V	GND		"				E
"	"	"	20			"	"				GND	2.4 V		"				F
"	"	"	21			"	"							"		2.4 V	GND	G
"	"	"	22			"	"							"		GND	2.4 V	H
"	I _{BH2}	3010	23			5.5 V	"	GND						"				A
"	"	"	24			GND	"	5.5 V						"				B
"	"	"	25			"	"		5.5 V	GND				"				C
"	"	"	26			"	"		GND	5.5 V				"				D
"	"	"	27			"	"				5.5 V	GND		"				E
"	"	"	28			"	"				GND	5.5 V		"				F
"	"	"	29			"	"							"		5.5 V	GND	G
"	"	"	30			"	"							"		GND	5.5 V	H
"	I _{OS}	3011	31			GND	"	GND	GND	GND	GND	GND		"	GND	GND	GND	Y
"	I _{CC1}	3005	32			5.5 V	"	5.5 V	5.5 V	5.5 V	5.5 V	5.5 V		"		5.5 V	5.5 V	V _{CC}
"	I _{CC2}	3005	33			GND	"	GND	GND	GND	GND	GND		"		GND	GND	V _{CC}

TABLE III. Group A inspection for device type 04. - Continued
Terminal conditions (High ≥ 2.0 V, Low ≤ 0.8 V or open).

Subgroup	Symbol	MIL-STD-883 method	Cases A,B,D	1	2	3	4	5	6	7	8	9	10	11	12	13	14	Meas term
			Case C	11	12	1	14	13	2	3	4	5	6	7	8	9	10	
			Test No.	NC	NC	A	V _{CC}	B	C	D	E	F	NC	GND	Y	G	H	
1 T _C = +25°C	V _{IC}		34			-12 mA	4.5 V							"				A
	"		35				"	-12 mA						"				B
	"		36				"		-12 mA					"				C
	"		37				"			-12 mA				"				D
	"		38				"				-12 mA			"				E
	"		39				"					-12 mA		"				F
	"		40				"							"		-12 mA		G
"		41				"							"			-12 mA	H	
2	Same tests, terminal conditions and limits as for subgroup 1, except T _C = +125°C and V _{IC} tests are omitted.																	
3	Same tests, terminal conditions and limits as for subgroup 1, except T _C = -55°C and V _{IC} tests are omitted.																	
9	t _{PHL}	3003	42			IN	5.0 V	2.4 V	GND	GND	GND	GND		GND	OUT	GND	GND	A to
	t _{PLH}	(Fig 3)	43			"	"	"	"	"	"	"		"	"	"	"	A to
10 T _C = +125°C	t _{PHL}	"	44			"	"	"	"	"	"	"		"	"	"	"	A to
	t _{PLH}	"	45			"	"	"	"	"	"	"		"	"	"	"	A to
11	Same tests, terminal conditions and limits as for subgroup 10, except T _C = -55°C.																	

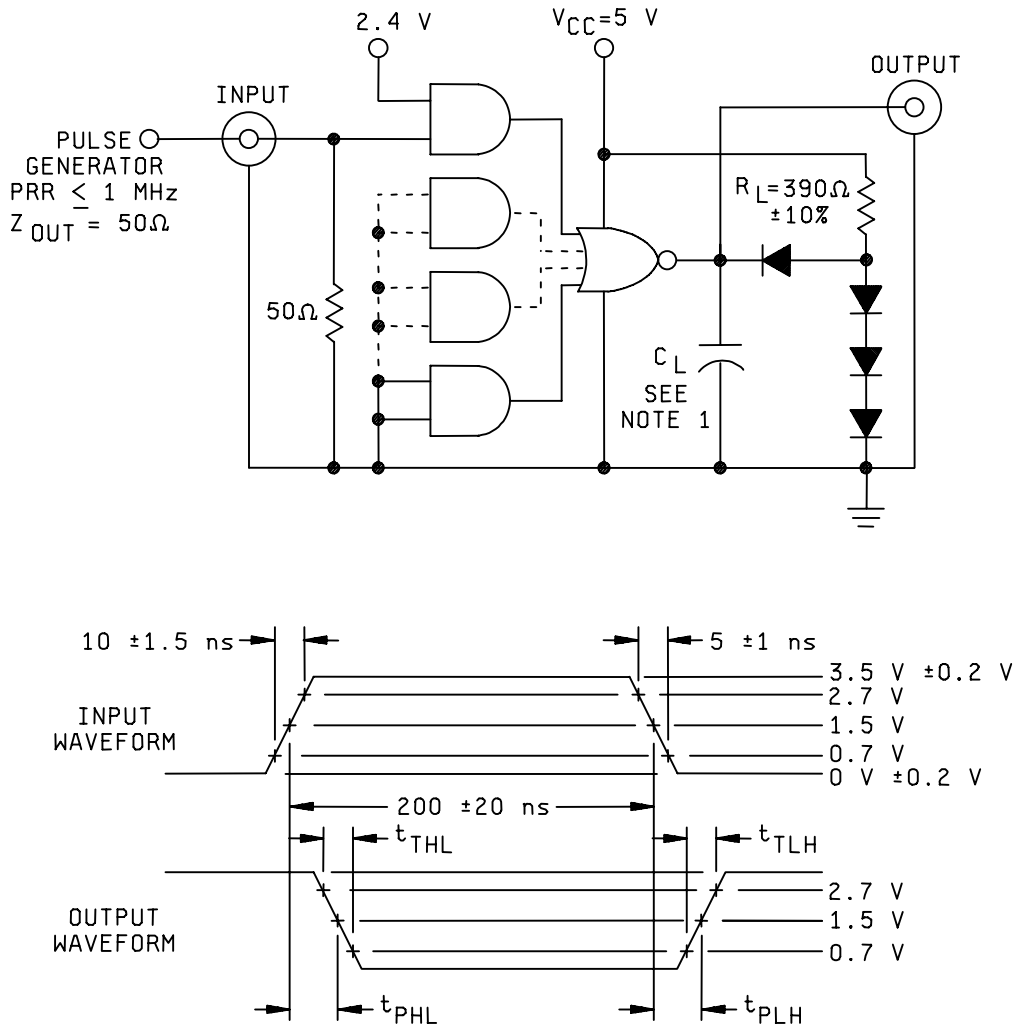

NOTES:

1. $C_L = 50$ pf including scope probe, wiring, and stray capacitance, without package in test fixture.
2. Voltage measurements are to be made with respect to network ground terminal.
3. All diodes are 1N3064 or equivalent.

FIGURE 3. Switching time test circuit.

DEVICE TYPE 01

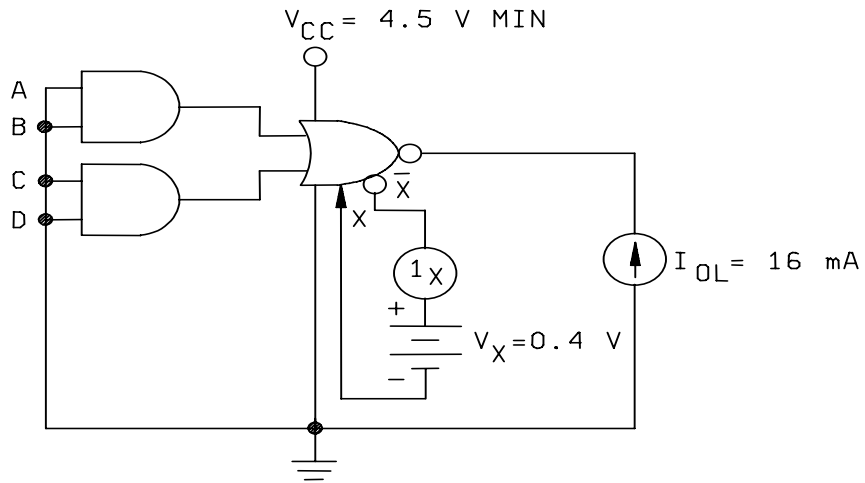

DEVICE TYPE 03

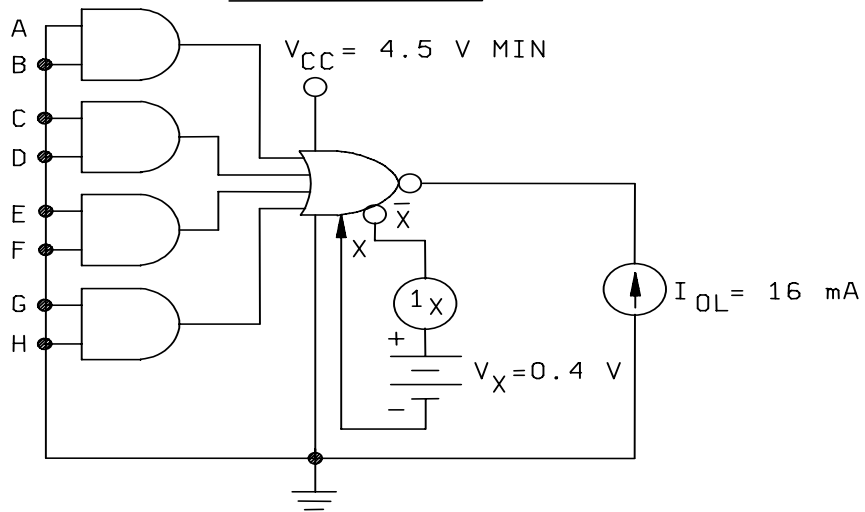

NOTE:

At the manufacturer's option, the expander test current limit may be verified by the use of an alternate procedure. The V_X voltage source and the I_X meter may be replaced with a 138Ω resistor in parallel with a voltmeter between X and \bar{X} . When the applicable conditions are applied, the resultant voltage drop across the resistor is measured. The I_X limit of 2.9 mA is met if the resultant voltage does not exceed 0.4 V.

FIGURE 4. Expander current test circuit for device types 01 and 03.

DEVICE TYPE 01

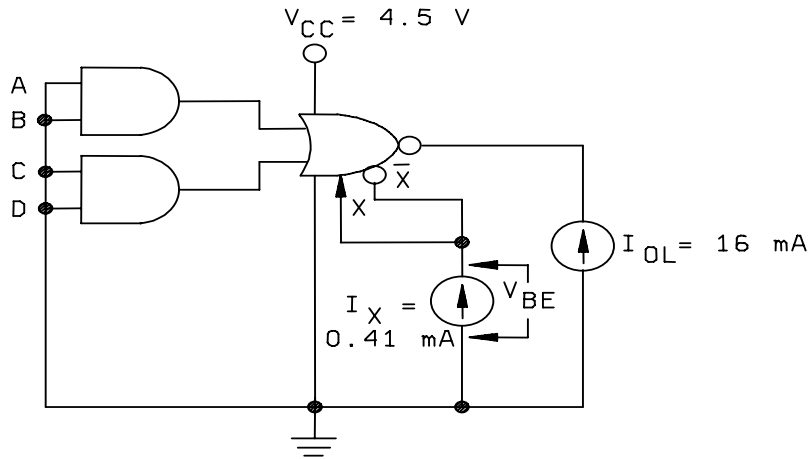

DEVICE TYPE 03

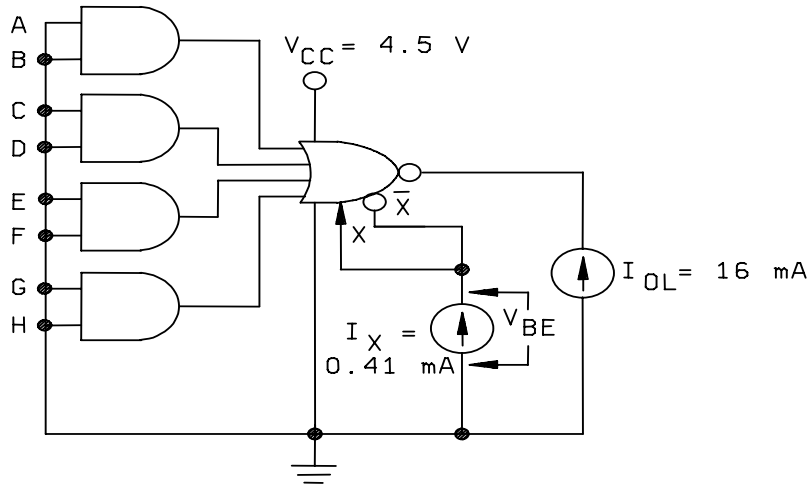

FIGURE 5. Base emitter voltage test circuit for device types 01 and 03.

5. PACKAGING

5.1 Packaging requirements. For acquisition purposes, the packaging requirements shall be as specified in the contract or order (see 6.2). When actual packaging of materiel is to be performed by DoD or in-house contractor personnel, these personnel need to contact the responsible packaging activity to ascertain packaging requirements. Packaging requirements are maintained by the Inventory Control Point's packaging activity within the Military Service or Defense Agency, or within the military service's system command. Packaging data retrieval is available from the managing Military Department's or Defense Agency's automated packaging files, CD-ROM products, or by contacting the responsible packaging activity.

6. NOTES

(This section contains information of a general or explanatory nature which may be helpful, but is not mandatory.)

6.1 Intended use. Microcircuits conforming to this specification are intended for original equipment design applications and logistic support of existing equipment.

6.2 Acquisition requirements. Acquisition documents should specify the following:

- a. Title, number, and date of the specification.
- b. PIN and compliance identifier, if applicable_ (see 1.2).
- c. Requirements for delivery of one copy of the conformance inspection data pertinent to the device inspection lot to be supplied with each shipment by the device manufacturer, if applicable.
- d. Requirements for certificate of compliance, if applicable.
- e. Requirements for notification of change of product or process to contracting activity in addition to notification to the qualifying activity, if applicable.
- f. Requirements for failure analysis (including required test condition of method 5003 of MIL-STD-883), corrective action, and reporting of results, if applicable.
- g. Requirements for product assurance options.
- h. Requirements for special carriers, lead lengths, or lead forming, if applicable. These requirements shall not affect the part number. Unless otherwise specified, these requirements will not apply to direct purchase by or direct shipment to the Government.
- l. Requirements for "JAN" marking.
- j. Packaging Requirements (see 5.1)

6.3 Superseding information. The requirements of MIL-M-38510 have been superseded to take advantage of the available Qualified Manufacturer Listing (QML) system provided by MIL-PRF-38535. Previous references to MIL-M-38510 in this document have been replaced by appropriate references to MIL-PRF-38535. All technical requirements now consist of this specification and MIL-PRF-38535. The MIL-M-38510 specification sheet number and PIN have been retained to avoid adversely impacting existing government logistics systems and contractor's parts lists.

6.4 Qualification. With respect to products requiring qualification, awards will be made only for products which are, at the time of award of contract, qualified for inclusion in Qualified Manufacturers List QML-38535 whether or not such products have actually been so listed by that date. The attention of the contractors is called to these requirements, and manufacturers are urged to arrange to have the products that they propose to offer to the Federal Government tested for qualification in order that they may be eligible to be awarded contracts or purchase orders for the products covered by this specification. Information pertaining to qualification of products may be obtained from DSCC-VQ, 3990 E. Broad Street, Columbus, Ohio 43123-1199.

MIL-M-38510/5D

6.5 Abbreviations, symbols, and definitions. The abbreviations, symbols, and definitions used herein are defined in MIL-PRF-38535, MIL-HDBK-1331, and as follows:

- GND Ground zero voltage potential
- V_{IN} Voltage level at an input terminal
- V_{IC} Input clamp voltage

6.6 Logistic support. Lead materials and finishes (see 3.4) are interchangeable. Unless otherwise specified, microcircuits acquired for Government logistic support will be acquired to device class B (see 1.2.2), lead material and finish A (see 3.4). Longer length leads and lead forming should not affect the part number.

6.7 Substitutability. The cross-reference information below is presented for the convenience of users. Microcircuits covered by this specification will functionally replace the listed generic-industry type. Generic-industry microcircuit types may not have equivalent operational performance characteristics across military temperature ranges or reliability factors equivalent to MIL-M-38510 device types and may have slight physical variations in relation to case size. The presence of this information should not be deemed as permitting substitution of generic-industry types for MIL-M-38510 types or as a waiver of any of the provisions of MIL-PRF-38535.

<u>Military device type</u>	<u>Generic-industry type</u>
01	5450 (Circuit A)
01	S5450 (Circuit B)
02	5451 (Circuit A)
02	S5451 (Circuit B)
03	5453 (Circuit A)
03	S5453 (Circuit B)
04	5454 (Circuit A)
04	S5454 (Circuit B)

6.8 Manufacturers' designation. Manufacturers' circuits which form a part of this specification are designated with an "X" as shown in table IV herein.

TABLE IV. Manufacturers' designation.

Device type	Circuit		
	A	B	C
	National Semiconductor	Texas Instruments	Motorola
01	X	X	X
02	X	X	X
03	X	X	X
04	X	X	X

MIL-M-38510/5D

6.9 Supersession information. MIL-M-38510/5D supersedes MIL-M-38510/5C. MIL-M-0038510/5B was issued as an "In lieu of" document for MIL-M-38510/5A and was superseded by MIL-M-38510/5C.

6.10 Change from previous issue. Marginal notations are not used in this revision to identify changes with respect to the previous issue, due to the extensiveness of the changes.

Custodians:

Army - CR
Navy - EC
Air Force - 11
DLA - CC

Preparing activity:

DLA - CC

Review activities:

Army – SM, MI
Navy - AS, CG, MC, SH TD
Air Force – 03, 19, 99

(Project 5962-2047)

NOTE: The activities listed above were interested in this document as of the date of this document. Since organization and responsibilities can change, you should verify the currency of the information above using the ASSIST Online database at www.dodssp.daps.mil.

X-ON Electronics

Largest Supplier of Electrical and Electronic Components

Click to view similar products for [Logic Gates](#) category:

Click to view products by [E2v](#) manufacturer:

Other Similar products are found below :

[5962-8769901BCA](#) [74HC85N](#) [NL17SG08P5T5G](#) [NL17SG32DFT2G](#) [NLU1G32AMUTCG](#) [NLV7SZ58DFT2G](#) [NLVHC1G08DFT1G](#)
[NLVVHC1G14DTT1G](#) [NLX2G08DMUTCG](#) [NLX2G08MUTCG](#) [MC74HCT20ADR2G](#) [091992B](#) [091993X](#) [093560G](#) [634701C](#) [634921A](#)
[NL17SG32P5T5G](#) [NL17SG86DFT2G](#) [NLU1G32CMUTCG](#) [NLV14001UBDR2G](#) [NLVVHC1G132DTT1G](#) [NLVVHC1G86DTT1G](#)
[NLX1G11AMUTCG](#) [NLX1G97MUTCG](#) [746427X](#) [74AUP1G17FW5-7](#) [74LS38](#) [74LVC1G08Z-7](#) [74LVC32ADTR2G](#) [74LVC1G125FW4-7](#)
[74LVC08ADTR2G](#) [MC74HCT20ADTR2G](#) [NLU1G08CMX1TCG](#) [NLV14093BDTR2G](#) [NLV17SZ00DFT2G](#) [NLV17SZ02DFT2G](#)
[NLV17SZ126DFT2G](#) [NLV27WZ17DFT2G](#) [NLV74HC02ADR2G](#) [NLV74HC08ADR2G](#) [NLVVHC1GT32DFT1G](#) [74HC32S14-13](#) [74LS133](#)
[74LVC1G32Z-7](#) [M38510/30402BDA](#) [74LVC1G86Z-7](#) [74LVC2G08RA3-7](#) [M38510/06202BFA](#) [NLV74HC08ADTR2G](#)
[NLV74HC14ADR2G](#)