

# LOW PROFILE LINE MATCHING TRANSFORMER

# P1165

## Features

- \* Low Profile (11mm)
- \* Vacuum encapsulated
- \* IEC 950, UL 1950 and EN 60950 certified
- \* UL Recognized Component
- \* BAPT Certificate of Recognition
- \* CSA NRTL/C Certificate of Compliance
- \* High Thermal Stability

## Applications

- \* Telecommunications
- \* Modems to V.34
- \* Line matching
- \* Portable computers
- \* Fax/modems
- \* Instrumentation
- \* Voice

---

## DESCRIPTION

P1165 is intended for data communications at V.32bis (14,400 bits/second) data rates. With careful circuit design, P1165 may be used for V.34 applications to 33,600 bits/second or higher.

P1165 is specifically designed to be easily matched to both 600ohm and complex impedance telephone lines, using a minimum of external components.

P1165 also exhibits stable characteristics over its operating temperature range to maximize data throughput under varying environmental conditions without the need for modem retraining.

P1165 is certified to IEC 950, EN 60950, EN 41003 and UL1950. P1165 is a UL Recognized Component and is supported by a BAPT Certificate of Recognition, a CSA Certificate of Compliance and an IEC CB Test Certificate.



## SPECIFICATIONS

### Electrical

At T = 25°C and as circuit fig. 2 unless otherwise stated.

Parameter	Conditions	Min	Typ	Max	Units	
Insertion Loss	f = 2kHz, R <sub>L</sub> = 560Ω	-	-	1.5	dB	
Frequency response	LF-3dB cutoff	-	30	-	Hz	
	HF-3dB cutoff	-	15	-	kHz	
	200Hz - 4kHz	-	-	±0.2	dB	
Return Loss	200Hz - 4kHz	18	-	-	dB	
Distortion <sup>(1)</sup>	0dBm in line, 3 <sup>rd</sup> Harmonic	-	-	-	-	
	f = 600Hz	-	-76	-72	dBm	
	f = 450Hz	-	-75	-70	dBm	
Balance	DC – 5kHz Method TG25	80	-	-	dB	
Saturation	Excitation 50Hz 250V rms.	-	-	10	V rms	
	Output voltage across line	-	-	65	V peak	
Voltage isolation <sup>(2)</sup>	50Hz	3.88	-	-	kVrms	
	DC	5.5	-	-	kV	
Operating range:	Ambient temperature	Functional	-10	-	+70	°C
		Storage	-40	-	+125	°C
		Humidity	-	-	95	%R.H.

Lumped equivalent circuit parameters as Fig. 1

DC resistance, R <sub>DC</sub> <sup>(3)</sup>	Sum of windings	108	-	132	Ω
Leakage inductance ΔL		6.5	-	7.5	mH
Shunt inductance L <sub>p</sub> <sup>(4)</sup>	-22dBm 200Hz	2.25	4	10	H
	-22dBm 1kHz	-	2.5	-	H
Shunt loss R <sub>p</sub> <sup>(4)</sup>	-43dBm 200Hz	8	-	-	kΩ
	-43dBm 1kHz	12	-	-	kΩ

### Notes

1. Third harmonic typically exceeds other harmonics by 20dB.
2. Components are 100% tested at 6.5kV DC.
3. Caution: do not pass DC through windings. Telephone line current, etc. must be diverted using choke or semiconductor line hold circuit.
4. At signal levels greater than -20dBm, L<sub>p</sub> will increase and R<sub>p</sub> will decrease slightly but the effect is usually favourable to the return loss characteristic.

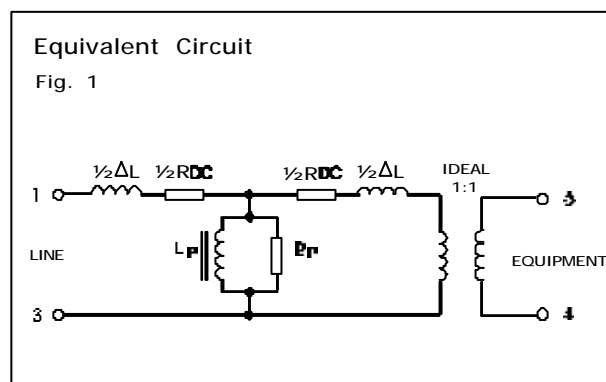

## PERFORMANCE CHARACTERISTICS

### 600Ω MATCH

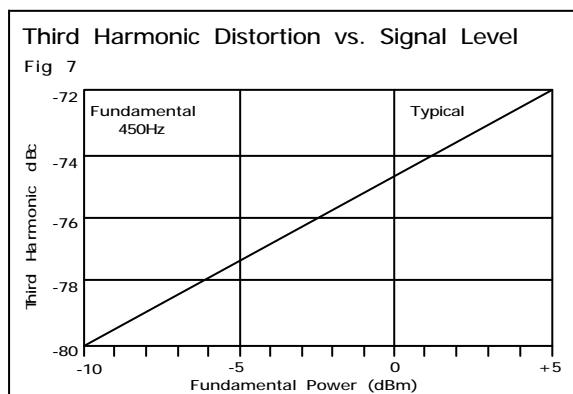
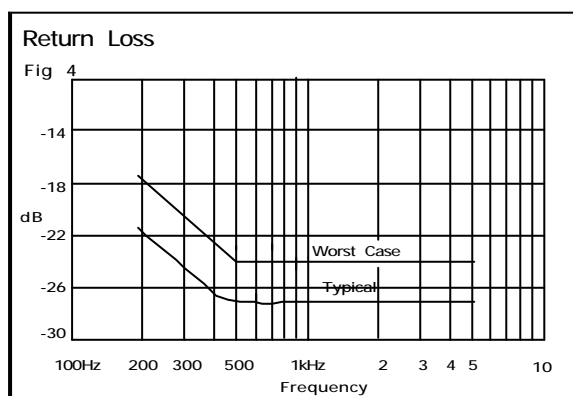
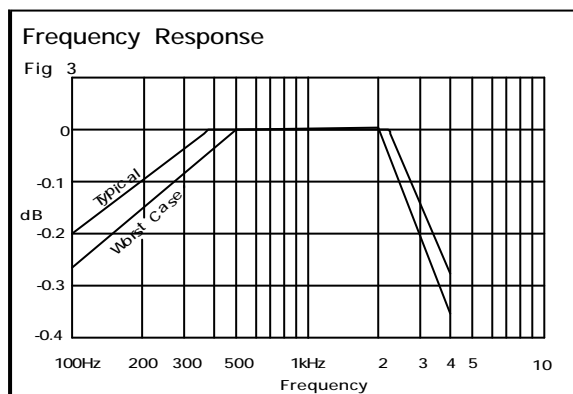
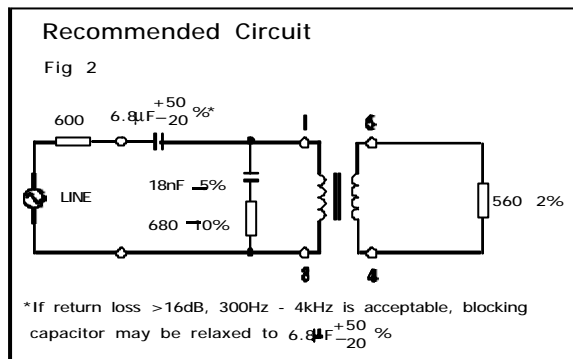

### EUROPEAN CTR21 COMPLEX MATCH

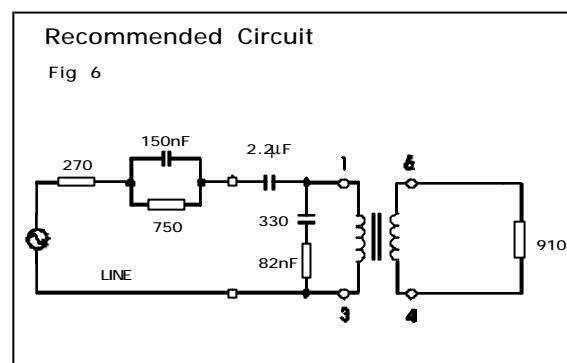
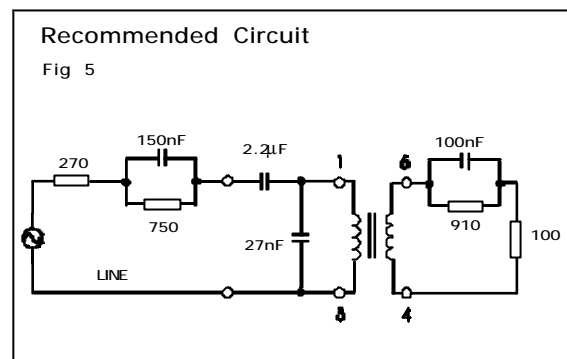
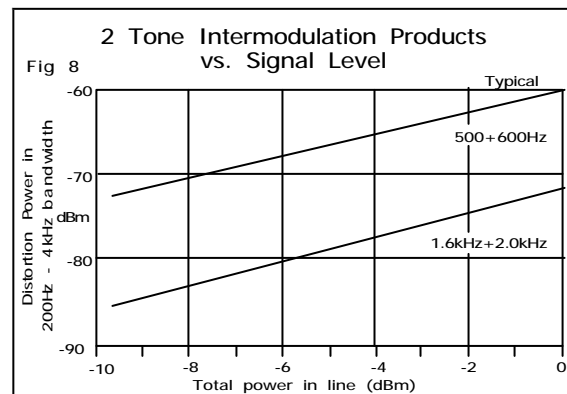

Figure 5 gives flat RX and TX responses against the reference impedance (typically around  $\pm 0.5$ dB 200Hz - 4kHz). Return loss is typically better than 20dB. The 150nF capacitor should be of a temperature stable dielectric. In practice, the 100ohm resistor will normally connect to a low impedance TX output.

For circuits with existing board drillings, figure 6 gives good return loss (>20dB) against the reference impedance, but TX and RX flatness are degraded by the use of this topology.

For recommended matching to other reference impedances please contact ETAL.



## CONSTRUCTION

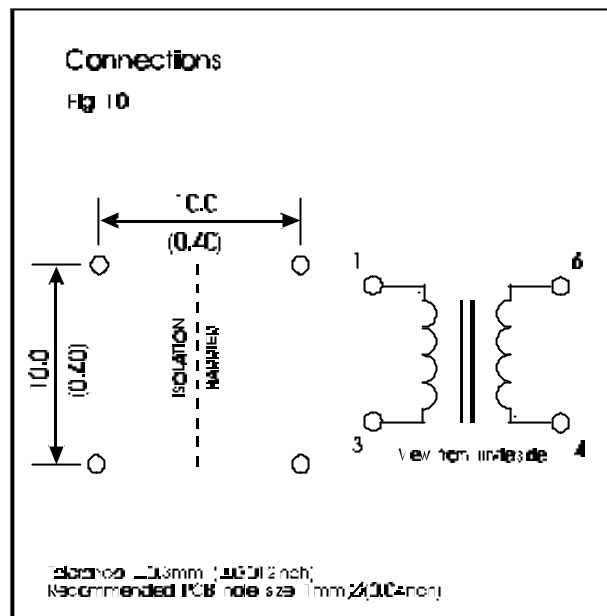
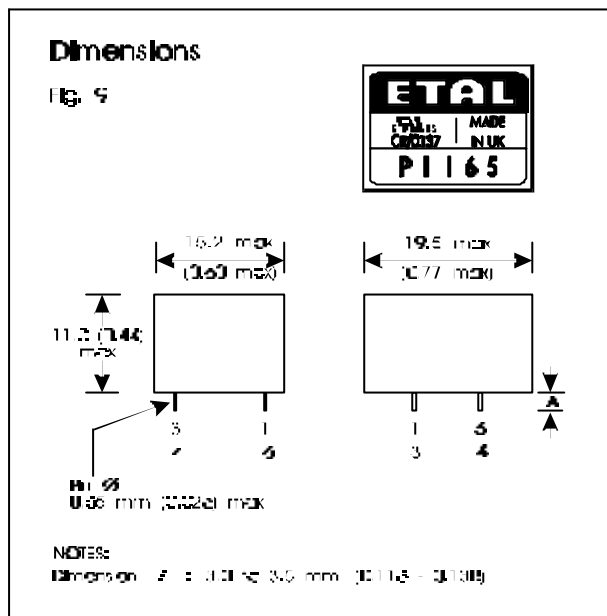

Dimensions shown are in millimetres (inches).

Geometric centres of outline and pin grid coincide within a tolerance circle of 0.6mm

Windings may be used interchangeably as primary or secondary.

## SAFETY

Constructed in accordance with IEC 950:1991, EN60950:1992 (BS7002:1992) to amendment 5, supplementary insulation, and UL 1950 3rd Edition, reinforced insulation, 250Vrms maximum working voltage, flammability class V-0.

Distances through solid insulation 0.4mm minimum.

## CERTIFICATION

Certified under the IEC CB scheme (Certificate GB443W) to IEC 950:1991, up to amendment 4, sub-clauses 2.2.2, 2.9.1, 2.9.6, 2.9.7, 4.4.3 (class V-0) and 5.3 for a maximum working voltage of 250Vrms, nominal mains supply voltage not exceeding 300Vrms and a maximum operating temperature of 70°C in Pollution Degree 2 environments, supplementary insulation.

Recognized under the Component Recognition Program of Underwriters Laboratories Inc. to US and Canadian requirements CAN/CSA C22.2 No. 950-95/UL1950, Third Edition, including revisions through to revision date March 1, 1998, based on Fourth Amendment of IEC 950, Second Edition, maximum working voltage 250Vrms, Pollution Degree 2, reinforced insulation.

UL File number E203175.

CSA Certificate of Compliance 1107696 (Master Contract 188107).

Approved and certified by BABT to EN 60950 and EN 41003.

BABT Certificate of Recognition CR/0137.

Additionally, Profec Technologies certifies all transformers as providing voltage isolation of 3.88kVrms, 5.5kV DC minimum. All shipments are supported by a Certificate of Conformity to current applicable safety standards.

**ABSOLUTE MAXIMUM RATINGS**

(Ratings of components independent of circuit).

Short term isolation voltage (2s)	4.6kVrms, 6.5kV DC
DC current	100 $\mu$ A
Storage temperature	-40°C to +125°C
Lead temperature, 10s	260°C

**COPYRIGHT**

ETAL, and P1165 are Trade Marks of Profec Technologies Ltd.

The Trade Mark ETAL is registered at the UK Trade Marks Registry.

Profec Technologies Ltd. is the owner of the design right under the Copyright Designs and Patents Act 1988 and no rights or licences are hereby granted or implied to any third party.

© 1997 - 2000 Profec Technologies Ltd.  
Reproduction prohibited.

**PROFEC**  
TRANSFORMING THE FUTURE



ISO 9001  
FM 25326

Profec Technologies Ltd., 10 Betts Avenue, Martlesham Heath, Ipswich, IP5 3RH, England  
Telephone: +44 (0) 1473 611422 Fax: +44 (0) 1473 611919  
Websites: [www.etal.ltd.uk](http://www.etal.ltd.uk) [www.profec.com](http://www.profec.com)  
Email: [info@etal.ltd.uk](mailto:info@etal.ltd.uk) [sales@profec.com](mailto:sales@profec.com)

## **X-ON Electronics**

Largest Supplier of Electrical and Electronic Components

*Click to view similar products for [etal manufacturer](#):*

Other Similar products are found below :

[P3181](#) [P3188](#) [P3000](#) [P3324](#) [P1165](#) [P3191](#) [P2781TR](#) [P2781](#) [P1200](#) [KRI193702](#) [KER300703](#)