

Precision Monolithic Quad SPST Low-Voltage CMOS Analog Switches

DESCRIPTION

The DG411L, DG412L, DG413L are low voltage pin-for-pin compatible companion devices to the industry standard DG411, DG412, DG413 with improved performance.

Using BiCMOS wafer fabrication technology allows the DG411L, DG412L, DG413L to operate on single and dual supplies. Single supply voltage ranges from 3 to 12 V while dual supply operation is recommended with ± 3 to ± 6 V.

Combining high speed (t_{ON} : 19 ns), flat $R_{DS(on)}$ over the analog signal range (5Ω), minimal insertion lose (-3 dB at 280 MHz), and excellent crosstalk and off-isolation performance (-50 dB at 50 MHz), the DG411L, DG412L, DG413L are ideally suited for audio and video signal switching.

The DG411L and DG412L respond to opposite control logic as shown in the Truth Table. The DG413L has two normally open and two normally closed switches.

FEATURES

- 2.7- thru 12 V single supply or ± 3 - thru ± 6 dual supply
- On-resistance - $R_{DS(on)}$: 17Ω
- Fast switching - t_{ON} : 19 ns
- t_{OFF} : 12 ns
- TTL, CMOS compatible
- Low leakage: 0.25 nA
- 2000 V ESD protection



BENEFITS

- Widest dynamic range
- Low signal errors and distortion
- Break-before-make switching action
- Simple interfacing

APPLICATIONS

- Precision automatic test equipment
- Precision data acquisition
- Communication systems
- Battery powered systems
- Computer peripherals
- SDSL, DSLAM
- Audio and video signal routing

FUNCTIONAL BLOCK DIAGRAM AND PIN CONFIGURATION

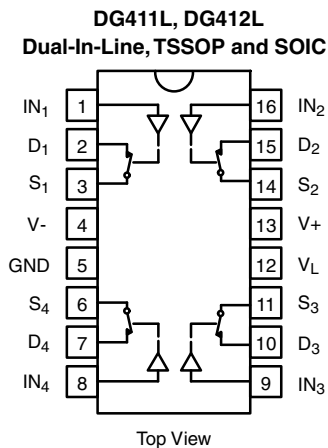

TRUTH TABLE		
Logic	DG411L	DG412L
0	ON	OFF
1	OFF	ON

Logic "0" ≤ 0.8 V
Logic "1" ≥ 2.4 V

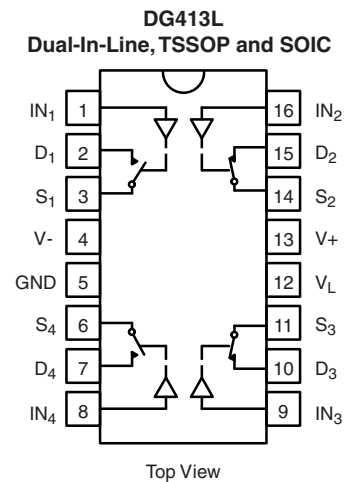

TRUTH TABLE		
Logic	SW ₁ , SW ₄	SW ₂ , SW ₃
0	OFF	ON
1	ON	OFF

Logic "0" ≤ 0.8 V
Logic "1" ≥ 2.4 V

* Pb containing terminations are not RoHS compliant, exemptions may apply

ORDERING INFORMATION		
Temp. Range	Package	Part Number
DG411L, DG412L		
- 40 °C to 85 °C	16-Pin Narrow SOIC	DG411LDY DG411LDY-E3 DG411LDY-T1 DG411LDY-T1-E3
		DG412LDY DG412LDY-E3 DG412LDY-T1 DG412LDY-T1-E3
	16-Pin TSSOP	DG411LDQ DG411LDQ-E3 DG411LDQ-T1 DG411LDQ-T1-E3
		DG412LDQ DG412LDQ-E3 DG412LDQ-T1 DG412LDQ-T1-E3
DG413L		
- 40 °C to 85 °C	16-Pin Narrow SOIC	DG413LDY DG413LDY-E3 DG413LDY-T1 DG413LDY-T1-E3
	16-Pin TSSOP	DG413LDQ DG413LDQ-E3 DG413LDQ-T1 DG413LDQ-T1-E3

ABSOLUTE MAXIMUM RATINGS			
Parameter		Limit	Unit
V ₊ to V ₋		- 0.3 to 13	V
GND to V ₋		7	
V _L		(GND - 0.3) to (V ₊) + 0.3	
I _N ^a , V _S , V _D		- 0.3 to (V ₊) + 0.3 or 30 mA, whichever occurs first	
Continuous Current (Any terminal)		30	mA
Peak Current, S or D (Pulsed 1 ms, 10 % duty cycle)		100	
Storage Temperature	(DQ, DY Suffix)	- 65 to 125	°C
	(AK Suffix)	- 65 to 150	
Power Dissipation (Packages) ^b	16-Pin TSSOP ^c	450	mW
	16-Pin SOIC ^d	650	
	16-Pin CerDIP ^e	900	

Notes:

a. Signals on S_X, D_X, or I_{NX} exceeding V₊ or V₋ will be clamped by internal diodes. Limit forward diode current to maximum current ratings.

b. All leads welded or soldered to PC board.

c. Derate 7 mW/°C above 75 °C

d. Derate 7.6 mW/°C above 75 °C

e. Derate 12 mW/°C above 75 °C.



SPECIFICATIONS ^a (Single Supply 12 V)									
Parameter	Symbol	Test Conditions Unless Otherwise Specified V ₊ = 12 V, V ₋ = 0 V V _L = 5 V, V _{IN} = 2.4 V, 0.8 V ^f	Temp. ^b	Typ. ^c	A Suffix Limits - 55 °C to 125 °C		D Suffix Limits - 40 °C to 85 °C		Unit
					Min. ^d	Max. ^d	Min. ^d	Max. ^d	
Analog Switch									
Analog Signal Range ^e	V _{ANALOG}		Full		0	12	0	12	V
Drain-Source On-Resistance	R _{DS(on)}	V ₊ = 10.8 V, V ₋ = 0 V I _S = 10 mA, V _D = 2/9 V	Room Full	20		30 45		30 40	Ω
Switch Off Leakage Current	I _{S(off)}	V _D = 1/11 V, V _S = 11/1 V	Room Full		- 1 - 15	1 15	- 1 - 10	1 10	nA
	I _{D(off)}		Room Full		- 1 - 15	1 15	- 1 - 10	1 10	
Channel On Leakage Current	I _{D(on)}	V _S = V _D = 11/1 V	Room Full		- 1 - 15	1 15	- 1 - 10	1 10	
Digital Control									
Input Current, V _{IN} Low	I _{IL}	V _{IN} under test = 0.8 V	Full	0.01	- 1.5	1.5	- 1	1	μA
Input Current, V _{IN} High	I _{IH}	V _{IN} under test = 2.4 V	Full		- 1.5	1.5	- 1	1	
Dynamic Characteristics									
Turn-On Time	t _{ON}	R _L = 300 Ω, C _L = 35 pF V _S = 5 V, see figure 2	Room Full	20		50 70		50 60	ns
Turn-Off Time	t _{OFF}		Room Full	12		30 48		30 40	
Break-Before-Make Time Delay	t _D	DG413L only, V _S = 5 V R _L = 300 Ω, C _L = 35 pF	Room	6					
Charge Injection ^e	Q	V _g = 0 V, R _g = 0 Ω, C _L = 10 nF	Room	5					pC
Off-Isolation ^e	OIRR	R _L = 50 Ω, C _L = 5 pF, f = 1 MHz	Room	71					dB
Channel-to-Channel Crosstalk ^e	X _{TALK}		Room	95					
Source Off Capacitance ^e	C _{S(off)}	f = 1 MHz	Room	5					pF
Drain Off Capacitance ^e	C _{D(off)}		Room	6					
Channel-On Capacitance ^e	C _{D(on)}		Room	15					
Power Supplies									
Positive Supply Current	I ₊	V _{IN} = 0 or 5 V	Room Full	0.02		1 7.5		1 5	μA
Negative Supply Current	I ₋		Room Full	- 0.002	- 1 - 7.5		- 1 - 5		
Logic Supply Current	I _L		Room Full	0.002		1 7.5		1 5	
Ground Current	I _{GND}		Room Full	- 0.002	- 1 - 7.5		- 1 - 5		

Notes:

- a. Refer to PROCESS OPTION FLOWCHART.
- b. Room = 25 °C, Full = as determined by the operating temperature suffix.
- c. Typical values are for DESIGN AID ONLY, not guaranteed nor subject to production testing.
- d. The algebraic convention whereby the most negative value is a minimum and the most positive a maximum, is used in this data sheet.
- e. Guaranteed by design, not subject to production test.
- f. V_{IN} = input voltage to perform proper function.
- g. Leakage parameters are guaranteed by worst case test conditions and not subject to test.

SPECIFICATIONS^a (Dual Supply ± 5 V)									
Parameter	Symbol	Test Conditions Unless Otherwise Specified $V_+ = 5$ V, $V_- = -5$ V $V_L = 5$ V, $V_{IN} = 2.4$ V, 0.8 V ^f	Temp. ^b	Ty.p ^c	A Suffix Limits - 55 °C to 125 °C		D Suffix Limits - 40 °C to 85 °C		Unit
					Min. ^d	Max. ^d	Min. ^d	Max. ^d	
Analog Switch									
Analog Signal Range ^e	V_{ANALOG}		Full		- 5	5	- 5	5	V
Drain-Source On-Resistance	$R_{DS(on)}$	$V_+ = 5$ V, $V_- = -5$ V $I_S = 10$ mA, $V_D = \pm 3.5$ V	Room Full	20		33 45		33 40	Ω
Switch Off Leakage Current ^g	$I_{S(off)}$	$V_+ = 5.5$ V, $V_- = -5.5$ V $V_D = \pm 4.5$ V, $V_S = \pm 4.5$ V	Room Full		- 1 - 15	1 15	- 1 - 10	1 10	nA
	$I_{D(off)}$		Room Full		- 1 - 15	1 15	- 1 - 10	1 10	
Channel On Leakage Current ^g	$I_{D(on)}$	$V_+ = 5.5$ V, $V_- = -5.5$ V $V_S = V_D = \pm 4.5$ V	Room Full		- 1 - 15	1 15	- 1 - 10	1 10	
Digital Control									
Input Current, V_{IN} Low ^e	I_{IL}	V_{IN} under test = 0.8 V	Full	0.05	- 1.5	1.5	- 1	1	μ A
Input Current, V_{IN} High ^e	I_{IH}	V_{IN} under test = 2.4 V	Full	0.05	- 1.5	1.5	- 1	1	
Dynamic Characteristics									
Turn-On Time ^e	t_{ON}	$R_L = 300 \Omega$, $C_L = 35$ pF $V_S = \pm 3.5$ V, see figure 2	Room Full	21		50 70		50 60	ns
Turn-Off Time ^e	t_{OFF}		Room Full	16		35 50		35 40	
Break-Before-Make Time Delay ^e	t_D	DG413L only, $V_S = 3.5$ V $R_L = 300 \Omega$, $C_L = 35$ pF	Room	6					
Charge Injection ^e	Q	$V_g = 0$ V, $R_g = 0 \Omega$, $C_L = 10$ nF	Room	5					pC
Off Isolation ^e	OIRR	$R_L = 50 \Omega$, $C_L = 5$ pF, $f = 1$ MHz	Room	68					dB
Channel-to-Channel Crosstalk ^e	X_{TALK}		Room	85					
Source Off Capacitance ^e	$C_{S(off)}$	f = 1 MHz	Room	9					pF
Drain Off Capacitance ^e	$C_{D(off)}$		Room	9					
Channel On Capacitance ^e	$C_{D(on)}$		Room	20					
Power Supplies									
Positive Supply Current ^e	I_+	$V_{IN} = 0$ or 5 V	Room Full	0.03		1 7.5		1 5	μ A
Negative Supply Current ^e	I_-		Room Full	- 0.002	- 1 - 7.5		- 1 - 5		
Logic Supply Current ^e	I_L		Room Full	0.002		1 7.5		1 5	
Ground Current ^e	I_{GND}		Room Full	- 0.002	- 1 - 7.5		- 1 - 5		

Notes:

- Refer to PROCESS OPTION FLOWCHART.
- Room = 25 °C, Full = as determined by the operating temperature suffix.
- Typical values are for DESIGN AID ONLY, not guaranteed nor subject to production testing.
- The algebraic convention whereby the most negative value is a minimum and the most positive a maximum, is used in this data sheet.
- Guaranteed by design, not subject to production test.
- V_{IN} = input voltage to perform proper function.
- Leakage parameters are guaranteed by worst case test conditions and not subject to test.



SPECIFICATIONS ^a (Single Supply 5 V)									
Parameter	Symbol	Test Conditions Unless Otherwise Specified V ₊ = 5 V, V ₋ = 0 V V _L = 5 V, V _{IN} = 2.4 V, 0.8 V ^f	Temp. ^b	Typ. ^c	A Suffix Limits - 55 °C to 125 °C		D Suffix Limits - 40 °C to 85 °C		Unit
					Min. ^d	Max. ^d	Min. ^d	Max. ^d	
Analog Switch									
Analog Signal Range ^e	V _{ANALOG}		Full			5		5	V
Drain-Source On-Resistance ^e	R _{DS(on)}	V ₊ = 4.5 V I _S = 5 mA, V _D = 1 V, 3.5 V	Room Full	35		50 88		50 75	Ω
Dynamic Characteristics									
Turn-On Time ^e	t _{ON}	R _L = 300 Ω, C _L = 35 pF V _S = 3.5 V, see figure 2	Room Hot	27		50 90		50 60	ns
Turn-Off Time ^e	t _{OFF}		Room Hot	15		30 55		30 40	
Break-Before-Make Time Delay ^e	t _D	DG413L only, V _S = 3.5 V R _L = 300 Ω, C _L = 35 pF	Room	6					
Charge Injection ^e	Q	V _g = 0 V, R _g = 0 Ω, C _L = 10 nF	Room	0.5					pC
Power Supplies									
Positive Supply Current ^e	I ₊	V _{IN} = 0 or 5 V	Room Hot	0.02		1 7.5		1 5	μA
Negative Supply Current ^e	I ₋		Room Hot	- 0.002	- 1 - 7.5		- 1 - 5		
Logic Supply Current ^e	I _L		Room Hot	0.002		1 7.5		1 5	
Ground Current ^e	I _{GND}		Room Hot	- 0.002	- 1 - 7.5		- 1 - 5		

Notes:

- a. Refer to PROCESS OPTION FLOWCHART.
- b. Room = 25 °C, Full = as determined by the operating temperature suffix.
- c. Typical values are for DESIGN AID ONLY, not guaranteed nor subject to production testing.
- d. The algebraic convention whereby the most negative value is a minimum and the most positive a maximum, is used in this data sheet.
- e. Guaranteed by design, not subject to production test.
- f. V_{IN} = input voltage to perform proper function.
- g. Leakage parameters are guaranteed by worst case test conditions and not subject to test.

SPECIFICATIONS ^a (Single Supply 3 V)									
Parameter	Symbol	Test Conditions Unless Otherwise Specified $V_+ = 3\text{ V}$, $V_- = 0\text{ V}$ $V_L = 3\text{ V}$, $V_{IN} = 0.4\text{ V}^f$	Temp. ^b	Typ. ^c	A Suffix Limits - 55 °C to 125 °C		D Suffix Limits - 40 °C to 85 °C		Unit
					Min. ^d	Max. ^d	Min. ^d	Max. ^d	
Analog Switch									
Analog Signal Range ^e	V_{ANALOG}		Full		0	3	0	3	V
Drain-Source On-Resistance	$R_{DS(on)}$	$V_+ = 2.7\text{ V}$, $V_- = 0\text{ V}$ $I_S = 5\text{ mA}$, $V_D = 0.5, 2.2\text{ V}$	Room Full	65		80 115		80 100	Ω
Switch Off Leakage Current ^g	$I_{S(off)}$	$V_+ = 3.3$, $V_- = 0\text{ V}$ $V_D = 1, 2\text{ V}$, $V_S = 2, 1\text{ V}$	Room Full		- 1 - 15	1 15	- 1 - 10	1 10	nA
	$I_{D(off)}$		Room Full		- 1 - 15	1 15	- 1 - 10	1 10	
Channel On Leakage Current ^g	$I_{D(on)}$	$V_+ = 3.3\text{ V}$, $V_- = 0\text{ V}$ $V_S = V_D = 1, 2\text{ V}$	Room Full		- 1 - 15	1 15	- 1 - 10	1 10	
Digital Control									
Input Current, V_{IN} Low	I_{IL}	V_{IN} under test = 0.4 V	Full	0.005	- 1.5	1.5	- 1	1	μA
Input Current, V_{IN} High	I_{IH}	V_{IN} under test = 2.4 V	Full	0.005	- 1.5	1.5	- 1	1	
Dynamic Characteristics									
Turn-On Time	t_{ON}	$R_L = 300\ \Omega$, $C_L = 35\text{ pF}$ $V_S = 1.5\text{ V}$, see figure 2	Room Full	50		85 150		85 110	ns
Turn-Off Time	t_{OFF}		Room Full	30		60 100		60 85	
Break-Before-Make Time Delay	t_D	DG413L only, $V_S = 1.5\text{ V}$ $R_L = 300\ \Omega$, $C_L = 35\text{ pF}$	Room	6					
Charge Injection ^e	Q	$V_g = 0\text{ V}$, $R_g = 0\ \Omega$, $C_L = 10\text{ nF}$	Room	1					pC
Off Isolation ^e	OIRR	$R_L = 50\ \Omega$, $C_L = 5\text{ pF}$, $f = 1\text{ MHz}$	Room	68					dB
Channel-to-Channel Crosstalk ^e	X_{TALK}		Room	85					
Source Off Capacitance ^e	$C_{S(off)}$	f = 1 MHz	Room	6					pF
Drain Off Capacitance ^e	$C_{D(off)}$		Room	6					
Channel On Capacitance ^e	$C_{D(on)}$		Room	20					

Notes:

- Refer to PROCESS OPTION FLOWCHART.
- Room = 25 °C, Full = as determined by the operating temperature suffix.
- Typical values are for DESIGN AID ONLY, not guaranteed nor subject to production testing.
- The algebraic convention whereby the most negative value is a minimum and the most positive a maximum, is used in this data sheet.
- Guaranteed by design, not subject to production test.
- V_{IN} = input voltage to perform proper function.
- Leakage parameters are guaranteed by worst case test conditions and not subject to test.

Stresses beyond those listed under "Absolute Maximum Ratings" may cause permanent damage to the device. These are stress ratings only, and functional operation of the device at these or any other conditions beyond those indicated in the operational sections of the specifications is not implied. Exposure to absolute maximum rating conditions for extended periods may affect device reliability.

TYPICAL CHARACTERISTICS (25 °C, unless otherwise noted)

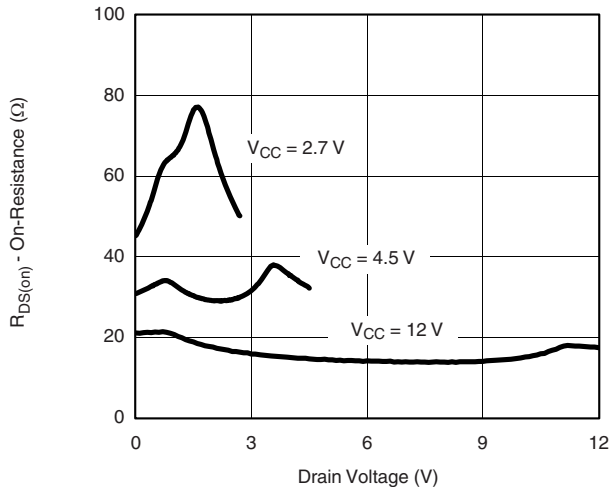

$R_{DS(on)}$ vs. Drain Voltage (Single Supply)

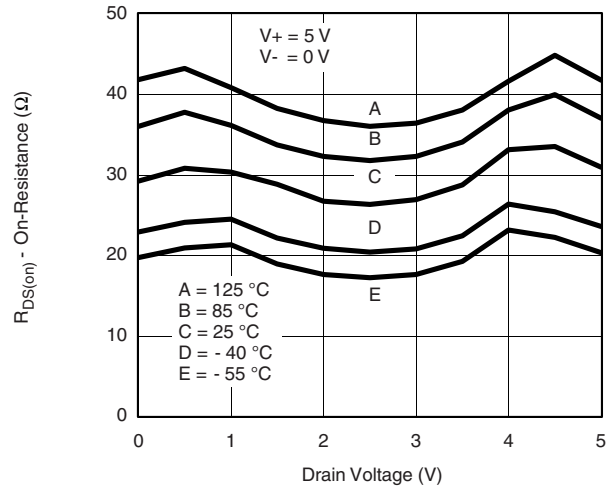

$R_{DS(on)}$ vs. Drain Voltage and Temperature (Single Supply)

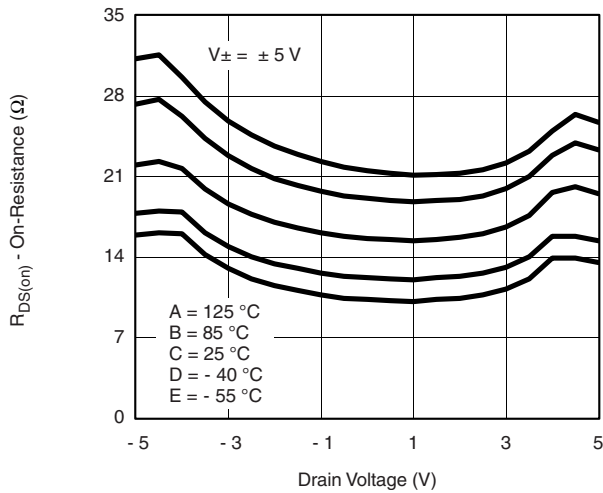

$R_{DS(on)}$ vs. Drain Voltage and Temperature (Dual Supply)

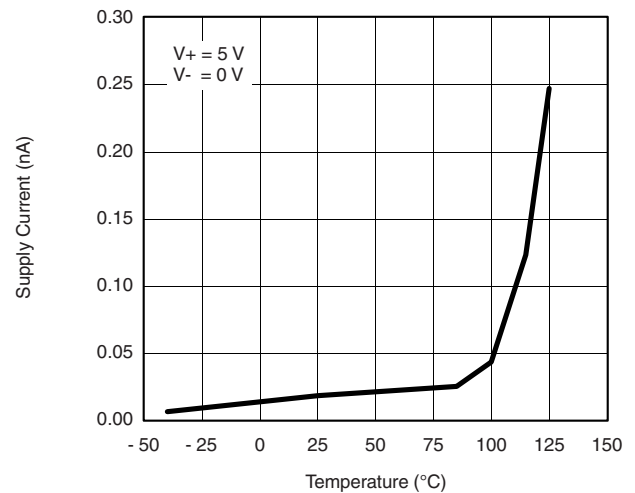

Supply Current vs. Temperature

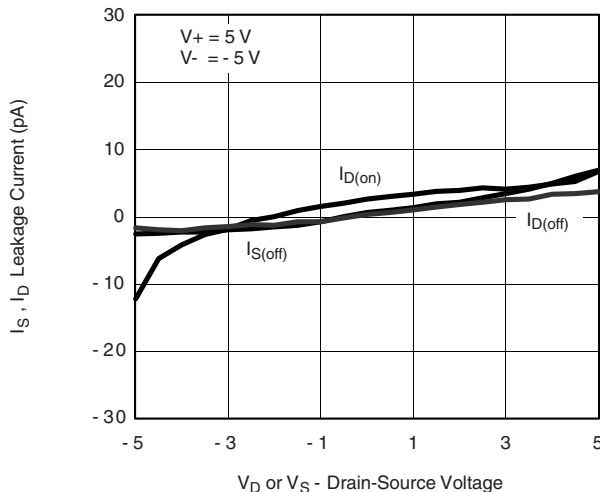

Leakage Current vs. Analog Voltage (Dual Supply)

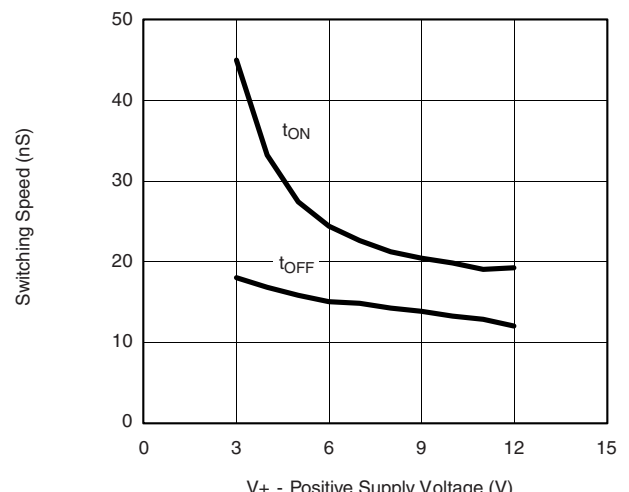

Switching Time vs. Single Supply

TYPICAL CHARACTERISTICS (25 °C, unless otherwise noted)

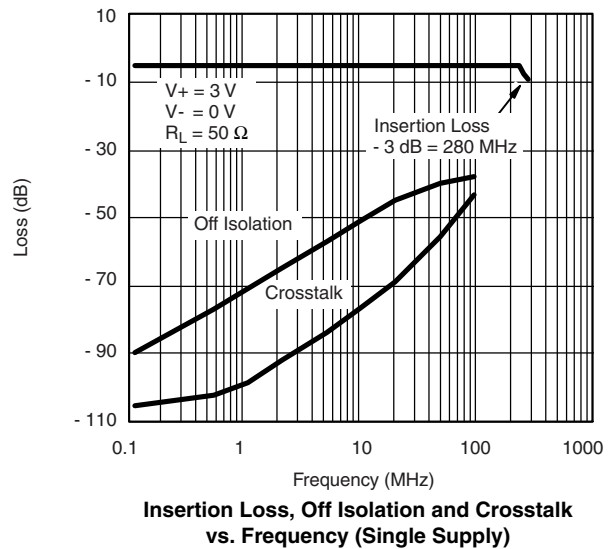
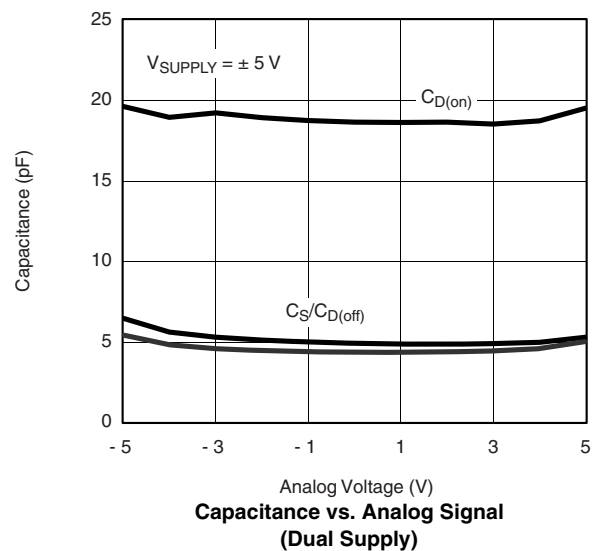
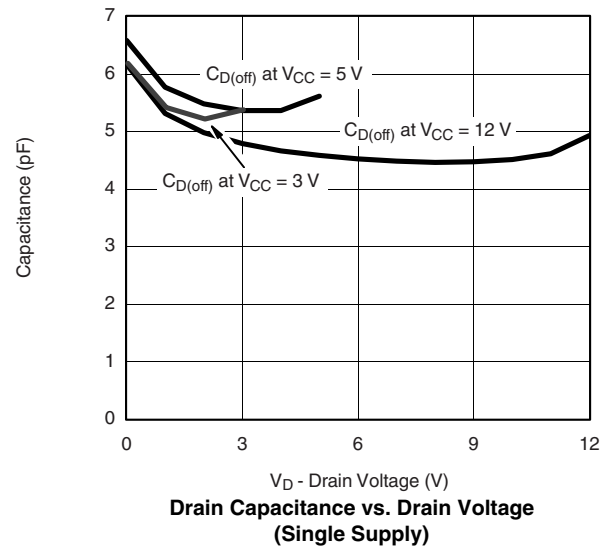
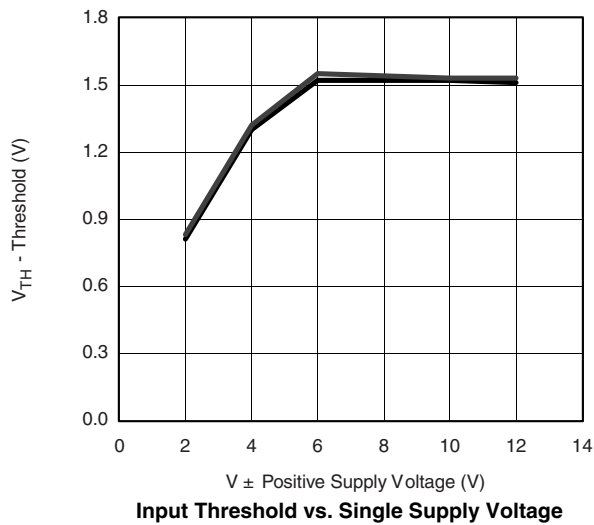
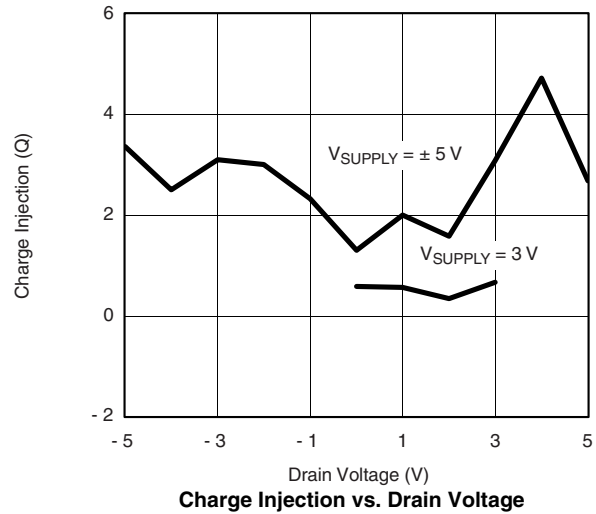
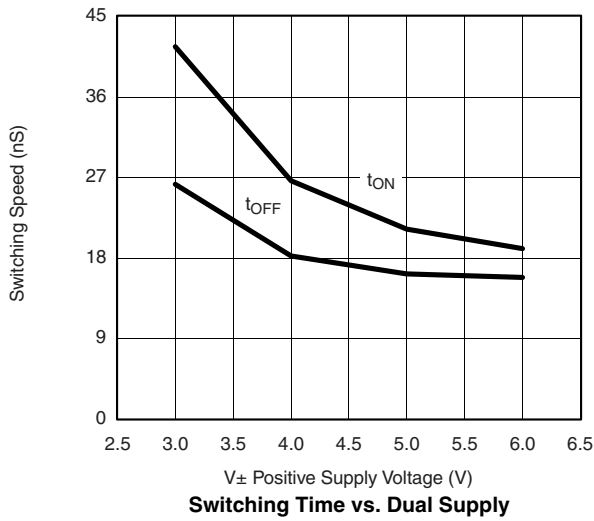

SCHEMATIC DIAGRAM (Typical Channel)

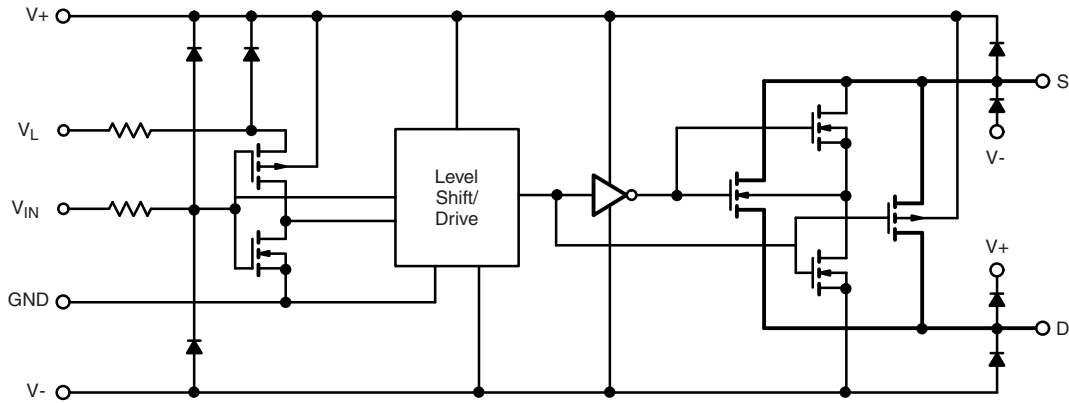
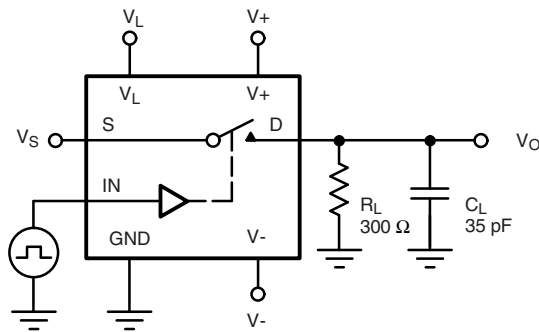

Figure 1.

TEST CIRCUITS



C_L (includes fixture and stray capacitance)

$$V_O = V_S \frac{R_L}{R_L + r_{DS(on)}}$$

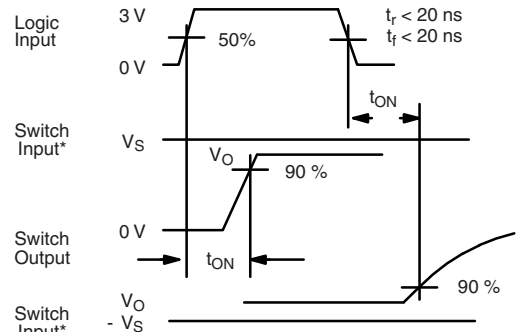

Note: Logic input waveform is inverted for switches that have the opposite logic sense control

Figure 2. Switching Time

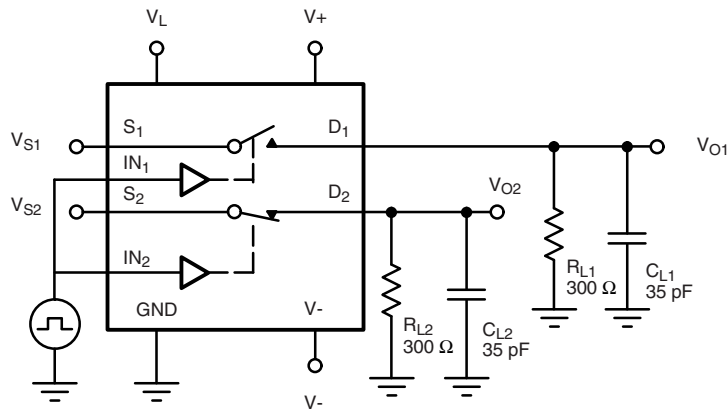

C_L (includes fixture and stray capacitance)

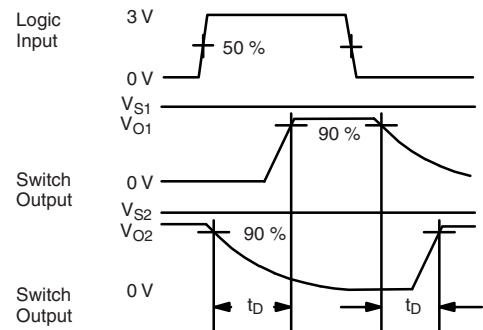

Figure 3. Break-Before-Make (DG413L)

TEST CIRCUITS

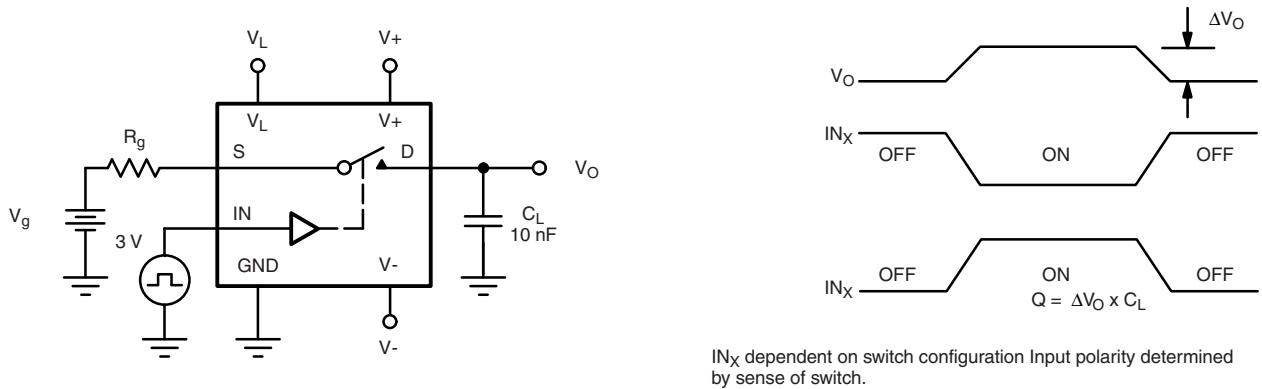

Figure 4. Charge Injection

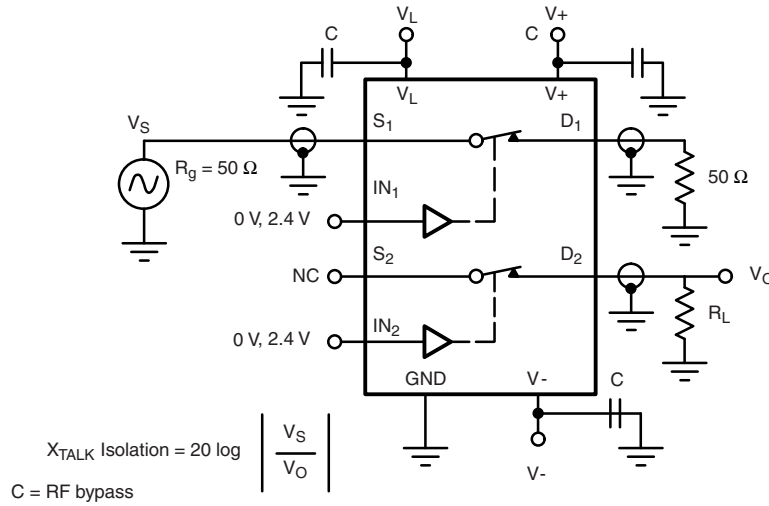

Figure 5. Crosstalk

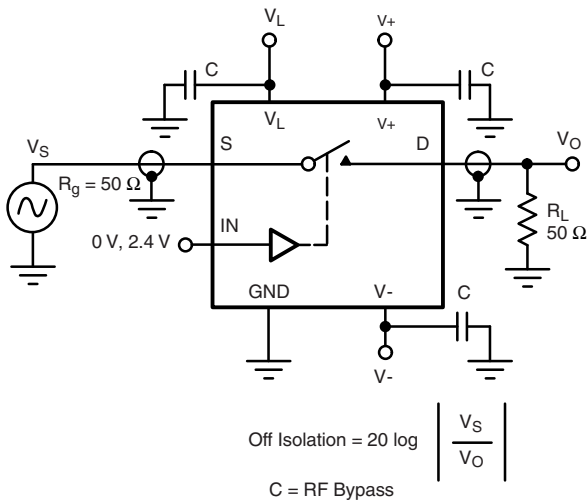

Figure 6. Off-Isolation

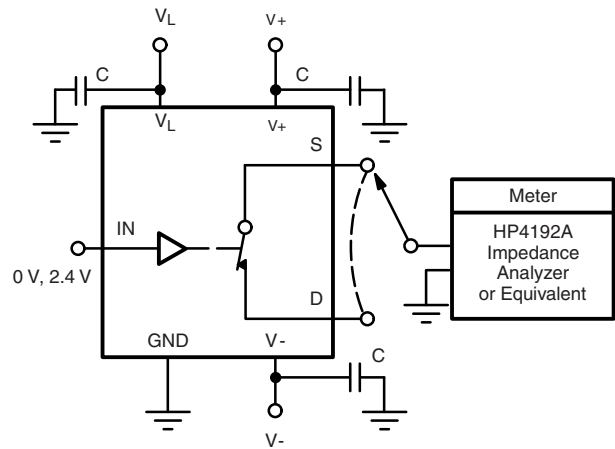

Figure 7. Source/Drain Capacitances

Vishay Siliconix maintains worldwide manufacturing capability. Products may be manufactured at one of several qualified locations. Reliability data for Silicon Technology and Package Reliability represent a composite of all qualified locations. For related documents such as package/tape drawings, part marking, and reliability data, see www.vishay.com/ppg?71397.



SOIC (NARROW): 16-LEAD
JEDEC Part Number: MS-012



Dim	MILLIMETERS		INCHES	
	Min	Max	Min	Max
A	1.35	1.75	0.053	0.069
A ₁	0.10	0.20	0.004	0.008
B	0.38	0.51	0.015	0.020
C	0.18	0.23	0.007	0.009
D	9.80	10.00	0.385	0.393
E	3.80	4.00	0.149	0.157
e	1.27 BSC		0.050 BSC	
H	5.80	6.20	0.228	0.244
L	0.50	0.93	0.020	0.037
∅	0°	8°	0°	8°

ECN: S-03946—Rev. F, 09-Jul-01
DWG: 5300



TSSOP: 16-LEAD

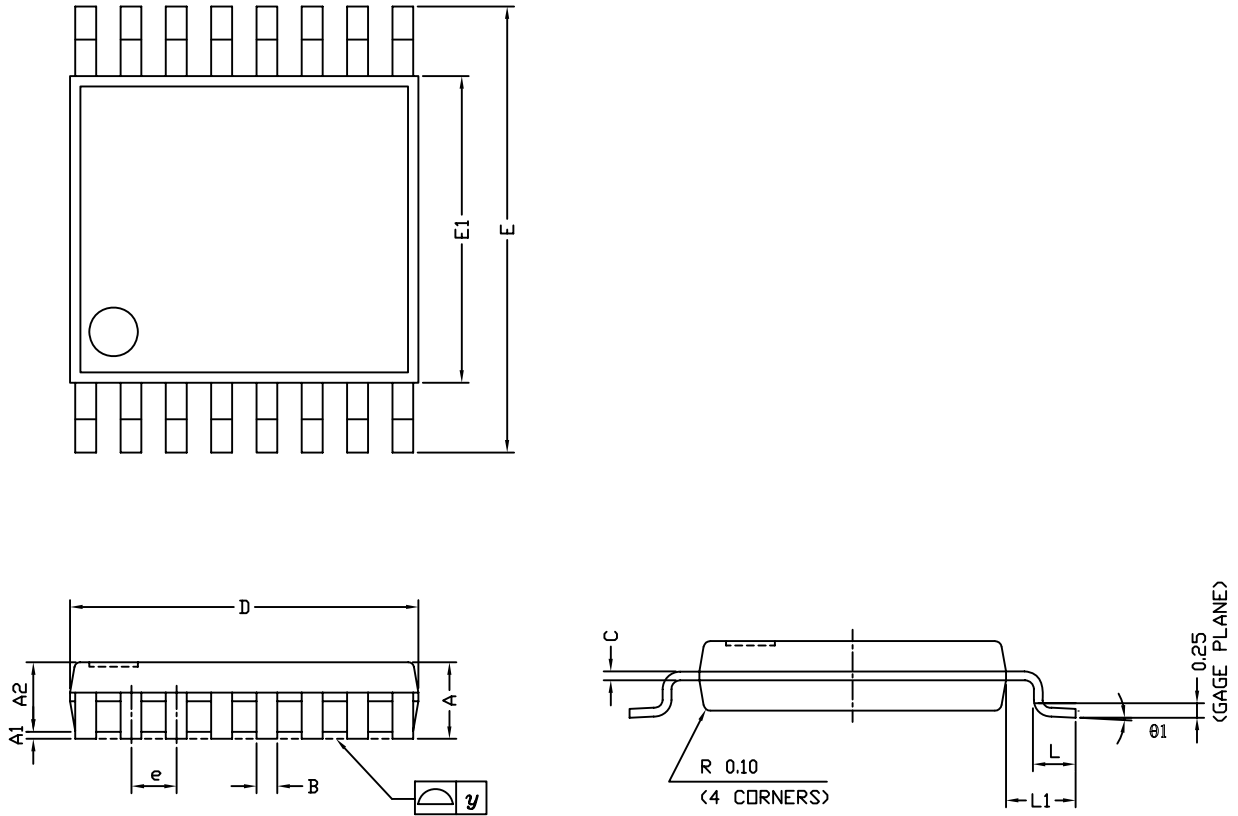

Symbols	DIMENSIONS IN MILLIMETERS		
	Min	Nom	Max
A	-	1.10	1.20
A1	0.05	0.10	0.15
A2	-	1.00	1.05
B	0.22	0.28	0.38
C	-	0.127	-
D	4.90	5.00	5.10
E	6.10	6.40	6.70
E1	4.30	4.40	4.50
e	-	0.65	-
L	0.50	0.60	0.70
L1	0.90	1.00	1.10
y	-	-	0.10
θ1	0°	3°	6°

ECN: S-61920-Rev. D, 23-Oct-06
DWG: 5624



RECOMMENDED MINIMUM PAD FOR TSSOP-16



Recommended Minimum Pads
Dimensions in inches (mm)

RECOMMENDED MINIMUM PADS FOR SO-16



Recommended Minimum Pads
Dimensions in Inches/(mm)

[Return to Index](#)



Disclaimer

ALL PRODUCT, PRODUCT SPECIFICATIONS AND DATA ARE SUBJECT TO CHANGE WITHOUT NOTICE TO IMPROVE RELIABILITY, FUNCTION OR DESIGN OR OTHERWISE.

Vishay Intertechnology, Inc., its affiliates, agents, and employees, and all persons acting on its or their behalf (collectively, "Vishay"), disclaim any and all liability for any errors, inaccuracies or incompleteness contained in any datasheet or in any other disclosure relating to any product.

Vishay makes no warranty, representation or guarantee regarding the suitability of the products for any particular purpose or the continuing production of any product. To the maximum extent permitted by applicable law, Vishay disclaims (i) any and all liability arising out of the application or use of any product, (ii) any and all liability, including without limitation special, consequential or incidental damages, and (iii) any and all implied warranties, including warranties of fitness for particular purpose, non-infringement and merchantability.

Statements regarding the suitability of products for certain types of applications are based on Vishay's knowledge of typical requirements that are often placed on Vishay products in generic applications. Such statements are not binding statements about the suitability of products for a particular application. It is the customer's responsibility to validate that a particular product with the properties described in the product specification is suitable for use in a particular application. Parameters provided in datasheets and / or specifications may vary in different applications and performance may vary over time. All operating parameters, including typical parameters, must be validated for each customer application by the customer's technical experts. Product specifications do not expand or otherwise modify Vishay's terms and conditions of purchase, including but not limited to the warranty expressed therein.

Except as expressly indicated in writing, Vishay products are not designed for use in medical, life-saving, or life-sustaining applications or for any other application in which the failure of the Vishay product could result in personal injury or death. Customers using or selling Vishay products not expressly indicated for use in such applications do so at their own risk. Please contact authorized Vishay personnel to obtain written terms and conditions regarding products designed for such applications.

No license, express or implied, by estoppel or otherwise, to any intellectual property rights is granted by this document or by any conduct of Vishay. Product names and markings noted herein may be trademarks of their respective owners.

X-ON Electronics

Largest Supplier of Electrical and Electronic Components

Click to view similar products for [Analog Switch ICs category](#):

Click to view products by [Vishay manufacturer](#):

Other Similar products are found below :

[DG9233EDY-GE3](#) [NLAS4684FCTCG](#) [NLAS5223BLMNR2G](#) [NLV74HC4066ADR2G](#) [MC74HC4067ADTG](#) [NLX2G66DMUTCG](#)
[NS5A4684SMNTAG](#) [732480R](#) [733995E](#) [425541DB](#) [425528R](#) [099044FB](#) [FSA221UMX](#) [MAX4888ETI+T](#) [MAX4968CEXB+](#)
[MAX4760EWX+T](#) [NLAS3799BMNR2G](#) [NLAS5123MNR2G](#) [NLAS5213AMUTAG](#) [NLAS7222AMTR2G](#) [MAX14807ECB+](#)
[MAX4968ECM+](#) [NLV14066BDG](#) [LC78615E-01US-H](#) [PI5A4599BCEX](#) [PI5A3157BZUEX](#) [ADG613SRUZ-EP](#) [NLAS4717EPFCT1G](#)
[PI5A3167CCEX](#) [MAX4744ELB+T](#) [MAX4802ACXZ+](#) [DG4051EEN-T1-GE4](#) [SLAS3158MNR2G](#) [PI5A3157BC6EX](#) [PI5A392AQE](#)
[MAX4744HELB+T](#) [PI5A4157ZUEX](#) [MC74HC4067ADTR2G](#) [PI5A4158ZAEX](#) [PI5A3166TAEX](#) [MAX4901EBL+T](#) [MAX14510EEVB+T](#)
[PI3A3899ZTEX](#) [MAX4996ETG+T](#) [MAX4889AETO+T](#) [MAX14508EEVB+T](#) [MAX4701ETE+T](#) [MAX4996LETG+T](#) [NLX2G66FCTAG](#)
[HI1-5051-2](#)