



Quad SPST CMOS Analog Switches

General Description

The DG202/DG212 are normally open, quad single-pole single-throw (SPST) analog switches. These CMOS switches can be continuously operated with power supplies ranging from $\pm 4.5\text{V}$ to $\pm 18\text{V}$. Maxim guarantees that these switches will not latch up if the power supplies are disconnected with input signals still connected.

The DG202/DG212 are similar to the DG201/DG211 except for inverted control inputs. All devices have guaranteed break-before-make switching, as well as essentially constant on-resistance over the analog signal range. All switches conduct current in either direction and add no offset to the output signal.

Compared to the original manufacturer's products, Maxim's DG202/DG212 consume very little power, making them better suited for portable applications. Maxim has also eliminated the need for the third logic power supply (V_L) that is required for the operation of the original manufacturer's DG212 without sacrificing compatibility.

Applications

Analog Multiplexers
 Programmable Gain Amplifiers
 Communications Systems
 Sample/Holds
 Automatic Test Equipment
 PBX, PABX

Typical Operating Circuit

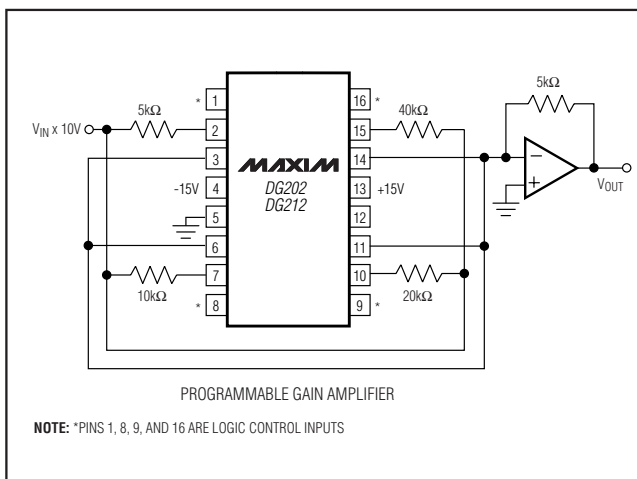

Features

- ◆ Guaranteed $\pm 4.5\text{V}$ to $\pm 18\text{V}$ Operation
- ◆ No V_L Supply Required
- ◆ Nonlatching with Supplies Turned Off and Input Signals Present
- ◆ CMOS and TTL Logic Compatible
- ◆ Monolithic, Low-Power CMOS Design

Ordering Information

PART	TEMP RANGE	PIN-PACKAGE
DG202CUE	0°C to +70°C	16 TSSOP
DG202CSE	0°C to +70°C	16 SO
DG202CJ	0°C to +70°C	16 Plastic DIP
DG202C/D	0°C to +70°C	Dice
DG202AEGE	-40°C to +85°C	16 QFN (5mm x 5mm)
DG202AEUE	-40°C to +85°C	16 TSSOP
DG202ADY	-40°C to +85°C	16 SO
DG202ADJ	-40°C to +85°C	16 Plastic DIP
DG202AK	-55°C to +125°C	16 CERDIP
DG212CUE	0°C to +70°C	16 TSSOP
DG212CSE	0°C to +70°C	16 SO
DG212CJ	0°C to +70°C	16 Plastic DIP
DG212C/D	0°C to +70°C	Dice
DG212EGE	-40°C to +85°C	16 QFN (5mm x 5mm)
DG212EUE	-40°C to +85°C	16 TSSOP
DG212DY	-40°C to +85°C	16 SO
DG212DJ	-40°C to +85°C	16 Plastic DIP
DG212ETE	-40°C to +85°C	16 Thin QFN

Pin Configurations

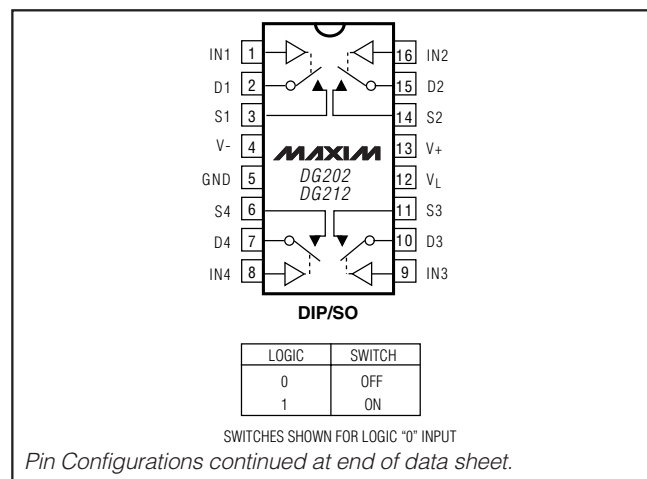

Quad SPST CMOS Analog Switches

ABSOLUTE MAXIMUM RATINGS (DG212)

V+ to V-	44V
V _{IN} to Ground	-V-, V+
V _L to Ground	-0.3V, 25V
V _S or V _D to V+	0, -40V
V _S or V _D to V-	0, 40V
V+ to Ground	25V
V- to Ground	-25V
Current, Any Terminal Except S or D	30mA
Continuous Current, S or D	20mA
Peak Current, S or D (pulsed at 1ms 10% duty cycle max)	70mA
Storage Temperature Range	-65°C to +125°C

Operating Temperature Range

DG212C	0°C to +70°C
DG212D/E	-40°C to +85°C
Power Dissipation (T _A = +70°C) (Note 1)	
16-Pin Plastic Dip (derate 10.5mW/°C above +70°C)	842mW
16-Pin Narrow SO (derate 8.7mW/°C above +70°C)	696mW
16-Pin TSSOP (derate 9.4mW/°C above +70°C)	755mW
16-Pin QFN (5mm x 5mm) (derate 19.2mW/°C above +70°C)	1538mW
16-Pin Thin QFN (derate 14.7mW/°C above +70°C)	1177mW

Note 1: Device mounted with all leads soldered to PC board.

Stresses beyond those listed under "Absolute Maximum Ratings" may cause permanent damage to the device. These are stress ratings only, and functional operation of the device at these or any other conditions beyond those indicated in the operational sections of the specifications is not implied. Exposure to absolute maximum rating conditions for extended periods may affect device reliability.

ELECTRICAL CHARACTERISTICS (DG212)

(V+ = +15V, V- = -15V, GND = 0, T_A = +25°C, unless otherwise noted.) (For more information on TYP values see Note 2.)

PARAMETER	SYMBOL	CONDITIONS	MIN	TYP	MAX	UNITS
SWITCH						
Analog Signal Range	V _{ANALOG}		-15		+15	V
Drain-Source ON-Resistance	R _{DS (ON)}	V _D = ±10V, V _{IN} = 2.4V, I _S = 1mA		115	175	Ω
Source OFF-Leakage Current	I _{S (OFF)}	V _{IN} = 0.8V V _S = 14V, V _D = -14V V _S = -14V, V _D = 14V	-5.0	0.01 -0.02	5.0	nA
Drain OFF-Leakage Current	I _{D (OFF)}	V _{IN} = 0.8V V _S = 14V, V _D = -14V V _S = -14V, V _D = 14V	-5.0	0.01 -0.02	5.0	
Drain ON-Leakage Current (Note 3)	I _{D (ON)}	V _S = V _D = 14V, V _{IN} = 2.4V V _S = V _D = -14V, V _{IN} = 2.4V	-5.0	0.1 -0.15	5.0	
INPUT						
Input Current with Input Voltage High	I _{INH}	V _{IN} = 2.4V V _{IN} = 15V	-1.0	-0.0004 0.003	1.0	μA
Input Current with Input Voltage Low	I _{INL}	V _{IN} = 0	-1.0	-0.0004		
DYNAMIC						
Turn-ON Time	t _{ON}	See Switching Time Test Circuit V _S = 2V, R _L = 1kΩ, C _L = 35pF		460	1000	ns
Turn-OFF Time	t _{OFF1}		360	500		
	t _{OFF2}		450			
Source OFF-Capacitance	C _{S (OFF)}	V _S = 0, V _{IN} = 0, f = 1MHz		5		pF
Drain OFF-Capacitance	C _{D (OFF)}	V _D = 0, V _{IN} = 0, f = 1MHz		5		
Channel ON-Capacitance	C _{D + S (ON)}	V _D = V _S = 0, V _{IN} = 5V, f = 1MHz		16		
OFF-Isolation (Note 4)	OIRR	V _{IN} = 0, R _L = 1kΩ, C _L = 15pF, V _S = 1VRMS, f = 100kHz		70		dB
Crosstalk (Channel to Channel)	CCRR		90			

Quad SPST CMOS Analog Switches

DG202/DG212

ELECTRICAL CHARACTERISTICS (DG212) (continued)

(V+ = +15V, V- = -15V, GND = 0, TA = +25°C, unless otherwise noted.) (For more information on TYP values see Note 2.)

PARAMETER	SYMBOL	CONDITIONS	MIN	TYP	MAX	UNITS
SUPPLY						
Positive Supply Current	I+	VIN = 0 and 2.4V (all)		0.02	0.4	mA
Negative Supply Current	I-			0.01	0.4	
Logic Supply Current	IL			0	0	
Power-Supply Range for Continuous Operation	VOP		±4.5		±18.0	V

Note 2: Typical values are for DESIGN AID ONLY, not guaranteed nor subject to production testing.

Note 3: ID(ON) is leakage from driver into "ON" switch.

Note 4: OFF-Isolation = 20 log VS/VD, VS = input to OFF switch, VD = output.

ABSOLUTE MAXIMUM RATINGS (DG202)

Voltages Reference to V-

V+44V

GND25V

Digital Inputs (Note 1), VS, VD-2V to (V+ + 2V)

or 20mA, whichever occurs first

Current, Any Terminal Except S or D30mA

Continuous Current, S or D20mA

Peak Current, S or D

(pulsed at 1ms 10% duty cycle max)70mA

Operating Temperature Range

DG202C0°C to +70°C

DG202D/E-40°C to +85°C

DG202A-55°C to +125°C

Storage Temperature Range-65°C to +150°C

Power Dissipation (Note 2)

16-Pin Plastic Dip (derate 10.5mW/°C above +70°C) ...842mW

16-Pin SO (derate 8.7mW/°C above +70°C)696mW

16-Pin TSSOP (derate 9.4mW/°C above +70°C)755mW

16-Pin QFN (5 × 5)

(derate 19.2mW/°C above +70°C)1538mW

16-Pin CERDIP (derate 10.0mW/°C above +70°C)800mW

Note 1: Signals on S, D, or IN exceeding V+ or V- on Maxim's DG202 will be clamped by internal diodes, and are also internally current limited to 25mA.

Note 2: Device mounted with all leads soldered to PC board.

Stresses beyond those listed under "Absolute Maximum Ratings" may cause permanent damage to the device. These are stress ratings only, and functional operation of the device at these or any other conditions beyond those indicated in the operational sections of the specifications is not implied. Exposure to absolute maximum rating conditions for extended periods may affect device reliability.

ELECTRICAL CHARACTERISTICS (DG202)

(V+ = +15V, V- = -15V, GND = 0, TA = +25°C, unless otherwise noted.) (For more information on TYP values see Note 3.)

PARAMETER	SYMBOL	CONDITIONS	DG202A			DG202C, D, E			UNITS	
			MIN	TYP	MAX	MIN	TYP	MAX		
SWITCH										
Analog Signal Range	VANALOG		-15		15	-15		15	V	
Drain-Source ON Resistance	RDS(ON)	VD = ±10V, VIN = 2.4V, IS = 1mA		115	175		115	200	Ω	
Source OFF-Leakage Current	IS(OFF)	VIN = 0.8V	VS = 14V, VD = -14V	0.01	1.0		0.01	5.0	nA	
			VS = -14V, VD = 14V	-1.0	-0.02		-1.0	-0.02		
Drain OFF-Leakage Current	ID(OFF)	VIN = 0.8V	VS = 14V, VD = -14V		0.01	1.0		0.01		5.0
			VS = -14V, VD = 14V	-1.0	-0.02		-1.0	-0.02		
Drain ON-Leakage Current (Note 4)	ID(ON)	VIN = 2.4V	VS = -14V		0.1	1.0		0.1	1.0	
			VS = 14V	-1.0			-5.0			

Quad SPST CMOS Analog Switches

DG202/DG212

ELECTRICAL CHARACTERISTICS (DG202) (continued)

(V+ = +15V, V- = -15V, GND = 0, T_A = +25°C, unless otherwise noted.) (For more information on TYP values see Note 3.)

PARAMETER	SYMBOL	CONDITIONS	DG202A			DG202C, D, E			UNITS
			MIN	TYP	MAX	MIN	TYP	MAX	
INPUT									
Input Current with Input Voltage High	I _{INH}	V _{IN} = 2.4V	-1.0	-0.0004		-1.0	-0.0004		μA
		V _{IN} = 15V		0.003	1.0		0.003	1.0	
Input Current with Input Voltage Low	I _{INL}	V _{IN} = 0	-1.0	-0.0004		-1.0	-0.0004		
DYNAMIC									
Turn-ON Time	t _{ON}	See Figure 1 Switching Time Test Circuit	480	600		480	600		ns
Turn-OFF Time	t _{OFF1}		370	450		370	450		
Charge Injection	Q	C _L = 1000pF, V _{GEN} = 0, R _{GEN} = 0	20			20			pC
Source OFF-Capacitance	C _{S (OFF)}	V _S = 0, V _{IN} = 0 f = 140kHz	5			5			pF
Drain OFF-Capacitance	C _{D (OFF)}		5			5			
Channel ON-Capacitance	C _{D (ON)} + C _{S (ON)}		V _D = V _S = 0, V _{IN} = 5V	16			16		
OFF-Isolation		V _{IN} = 0, Z _L = 75Ω	70			70			dB
Crosstalk (Channel to Channel)		V _S = 2.0V, f = 100kHz	90			90			
SUPPLY									
Positive Supply Current	I+	All channels ON or OFF	0.02	0.1		0.02	0.1		mA
Negative Supply Current	I-	All channels ON or OFF	-0.1	-0.01		-0.1	-0.01		
Power-Supply Range for Continuous Operation	V _{OP}		±4.5		±18	±4.5		±18.0	V

Note 3: Typical values are for DESIGN AID ONLY, not guaranteed nor subject to production testing.

Note 4: I_{D (ON)} is leakage from driver into "ON" switch.

Quad SPST CMOS Analog Switches

DG202/DG212

ELECTRICAL CHARACTERISTICS (DG202)

(V+ = +15V, V- = -15V, GND = 0, T_A = full operating temperature range, unless otherwise noted.) (For more information on TYP values see Note 3.)

PARAMETER	SYMBOL	CONDITIONS	DG202A			DG202C, D, E			UNITS
			MIN	TYP	MAX	MIN	TYP	MAX	
SWITCH									
Analog Signal Range	V _{ANALOG}		-15		+15	-15		+15	V
Drain-Source ON Resistance (Note 5)	R _{DS (ON)}	V _D = ±10V, V _{IN} = 2.4V, I _S = 1mA			250			250	Ω
Source OFF-Leakage Current	I _{S (OFF)}	V _{IN} = 0.8V	V _S = 14V, V _D = -14V			100			nA
			V _S = -14V, V _D = 14V			-100			
Drain OFF-Leakage Current	I _{D (OFF)}	V _{IN} = 0.8V	V _S = 14V, V _D = -14V			100			nA
			V _S = -14V, V _D = 14V			-100			
Drain ON-Leakage Current (Note 6)	I _{D (ON)}	V _{IN} = 2.4V	V _S = -14V			200			nA
			V _D = 14V			-200			
INPUT									
Input Current with Input Voltage High	I _{INH}	V _{IN} = 2.4V	-1.0			-1.0			μA
		V _{IN} = 15V				1.0			
Input Current with Input Voltage Low	I _{INL}	V _{IN} = 0	-1.0			-1.0			μA

Note 5: Electrical characteristics, such as On-Resistance, will change when power supplies other than ±15V, are used.

Note 6: I_{D (ON)} is leakage from driver into “ON” switch.

Pin Description

PIN		NAME	FUNCTION
DIP/SO/TSSOP	QFN/TQFN		
1, 16, 9, 8	15, 14, 7, 6	IN1–IN4	Input
2, 15, 10, 7	16, 13, 8, 5	D1–D4	Analog Switch Drain Terminal
3, 14, 11, 6	1, 12, 9, 4	S1–S4	Analog Switch Source Terminal
4	2	V-	Negative-Supply Voltage Input
5	3	GND	Ground
12	10	N.C.	No Connection
13	11	V+	Positive-Supply Voltage Input—Connected to Substrate
—	EP	EP	Exposed Pad. Connect exposed pad to V+ or leave EP unconnected.

Switching Time Test Circuit

Switch output waveform shown for V_S = constant with logic input waveform as shown. Note that V_S may be +ve or -ve as per switching times test circuit. V_O is the steady state output with switch on. Feedthrough via gate capacitance may result in spikes at leading and trailing edge of output waveform.

Protecting Against Fault Conditions

Fault conditions occur when power supplies are turned off when input signals are still present, or when over-voltages occur at the inputs during normal operation. In either case, source-to-body diodes can be forward biased and conduct current from the signal source. If

Quad SPST CMOS Analog Switches

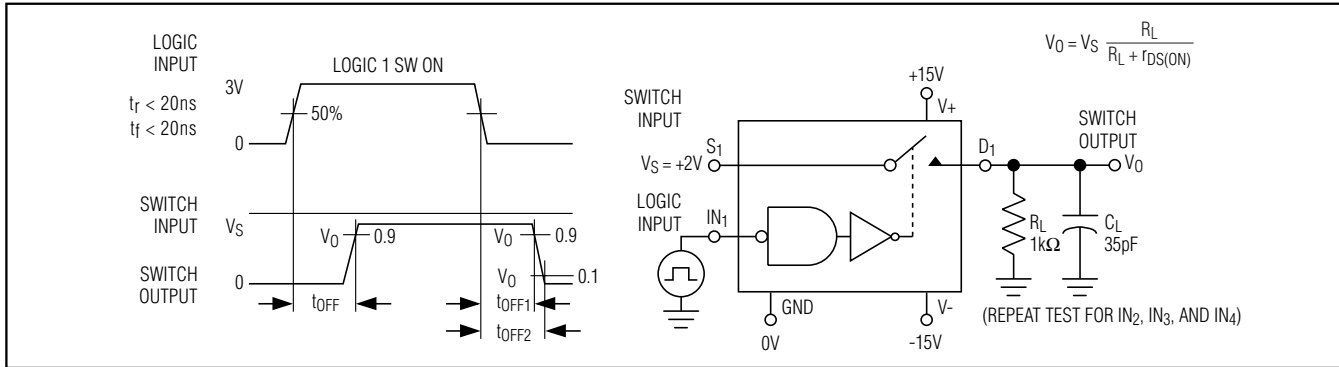

Figure 1. Switching Time

Typical RDS(ON) vs. Power Supplies for Maxim’s DG202, and DG212

POWER SUPPLIES	RDS(ON) AT ANALOG SIGNAL LEVEL					
	-5V	+5V	-10V	+10V	-15V	+15V
±5V	350Ω	380Ω	—	—	—	—
±10V	—	—	165Ω	250Ω	—	—
±15V	—	—	125Ω	160Ω	135Ω	155Ω

this current is required to be kept to low (μA) levels then the addition of external protection diodes is recommended.

To provide protection for overvoltages up to 20V above the supplies, a 1N4001 or 1N914 type diode should be placed in series with the positive and negative supplies as shown in Figure 2. The addition of these diodes will reduce the analog signal range to 1V below the positive supply and 1V above the negative supply.

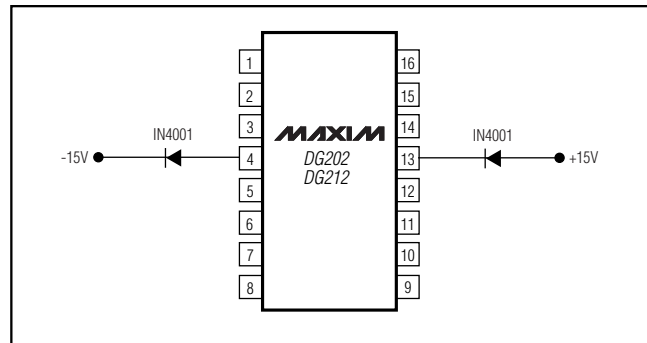
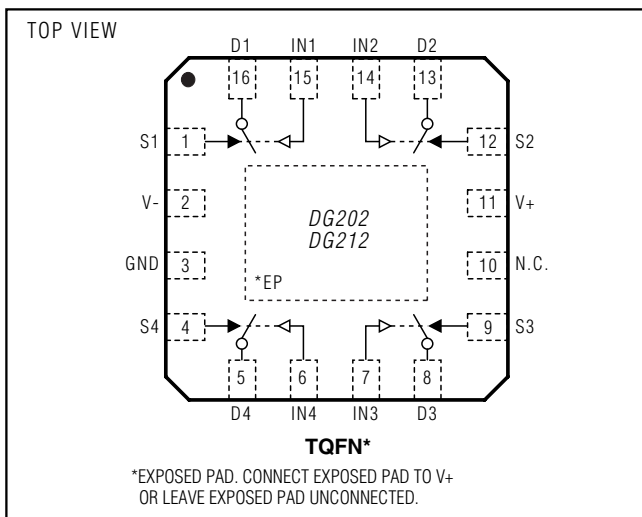

Figure 2. Protection against Fault Conditions

Pin Configurations (continued)



Quad SPST CMOS Analog Switches

Package Information

(The package drawing(s) in this data sheet may not reflect the most current specifications. For the latest package outline information, go to www.maxim-ic.com/packages.)

DG202/DG212

SOICN LEPS

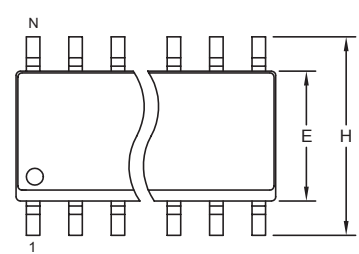

TOP VIEW

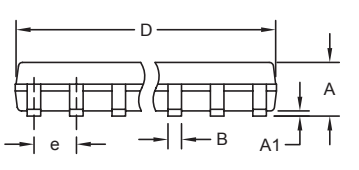

FRONT VIEW

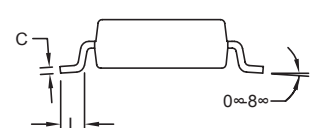

SIDE VIEW



DIM	INCHES		MILLIMETERS	
	MIN	MAX	MIN	MAX
A	0.053	0.069	1.35	1.75
A1	0.004	0.010	0.10	0.25
B	0.014	0.019	0.35	0.49
C	0.007	0.010	0.19	0.25
e	0.050 BSC		1.27 BSC	
E	0.150	0.157	3.80	4.00
H	0.228	0.244	5.80	6.20
L	0.016	0.050	0.40	1.27

VARIATIONS:

DIM	INCHES		MILLIMETERS		N	MS012
	MIN	MAX	MIN	MAX		
D	0.189	0.197	4.80	5.00	8	AA
D	0.337	0.344	8.55	8.75	14	AB
D	0.386	0.394	9.80	10.00	16	AC

NOTES:

1. D&E DO NOT INCLUDE MOLD FLASH.
2. MOLD FLASH OR PROTRUSIONS NOT TO EXCEED 0.15mm (.006").
3. LEADS TO BE COPLANAR WITHIN 0.10mm (.004").
4. CONTROLLING DIMENSION: MILLIMETERS.
5. MEETS JEDEC MS012.
6. N = NUMBER OF PINS.

PROPRIETARY INFORMATION

TITLE:
PACKAGE OUTLINE, .150" SOIC

APPROVAL	DOCUMENT CONTROL NO. 21-0041	REV. B	1/1
----------	---------------------------------	--------	-----

Quad SPST CMOS Analog Switches

Package Information (continued)

(The package drawing(s) in this data sheet may not reflect the most current specifications. For the latest package outline information, go to www.maxim-ic.com/packages.)

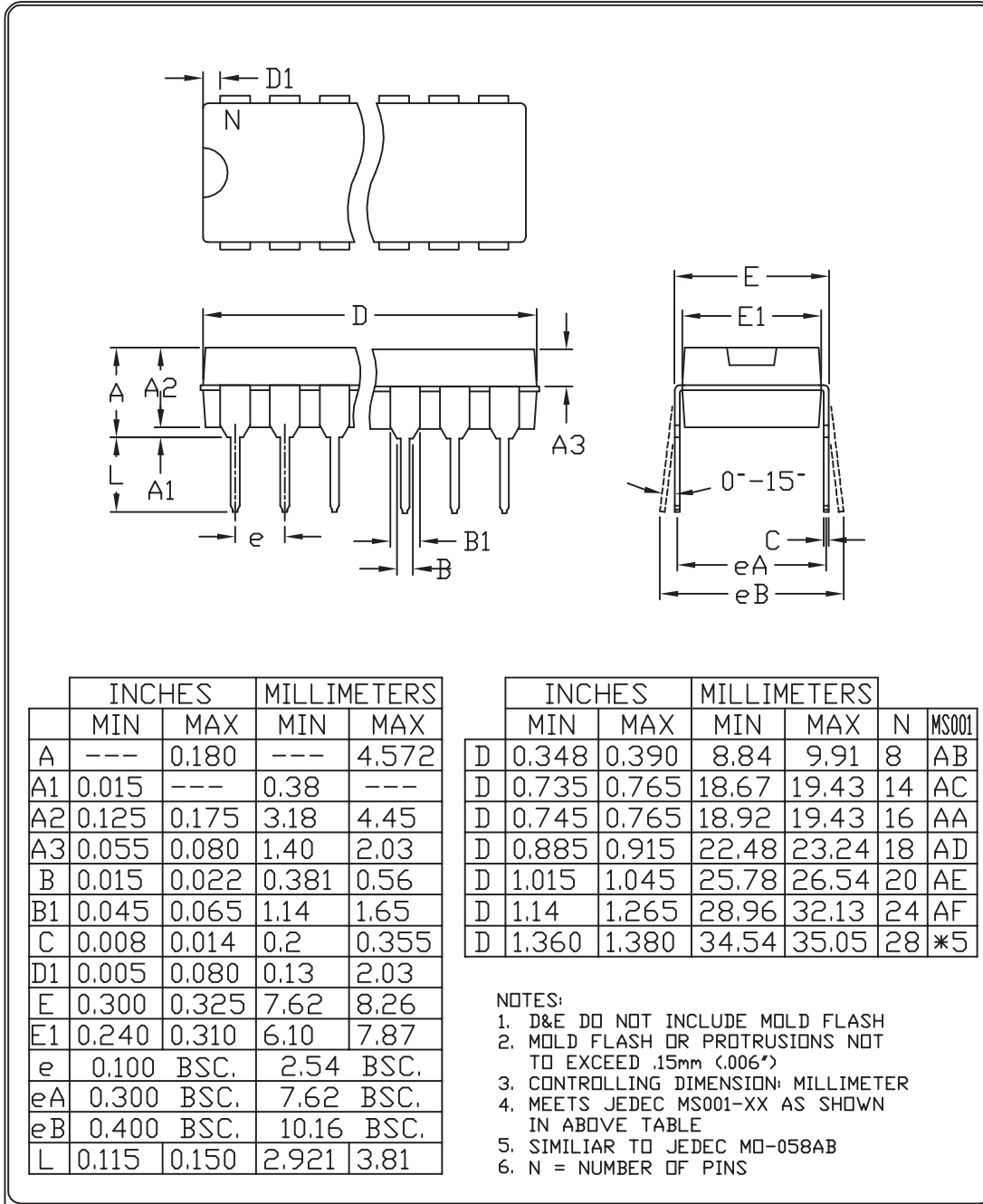

PDIPN.EPS

	INCHES		MILLIMETERS	
	MIN	MAX	MIN	MAX
A	---	0.180	---	4.572
A1	0.015	---	0.38	---
A2	0.125	0.175	3.18	4.45
A3	0.055	0.080	1.40	2.03
B	0.015	0.022	0.381	0.56
B1	0.045	0.065	1.14	1.65
C	0.008	0.014	0.2	0.355
D1	0.005	0.080	0.13	2.03
E	0.300	0.325	7.62	8.26
E1	0.240	0.310	6.10	7.87
e	0.100 BSC.		2.54 BSC.	
eA	0.300 BSC.		7.62 BSC.	
eB	0.400 BSC.		10.16 BSC.	
L	0.115	0.150	2.921	3.81

	INCHES		MILLIMETERS		N	MS001
	MIN	MAX	MIN	MAX		
D	0.348	0.390	8.84	9.91	8	AB
D	0.735	0.765	18.67	19.43	14	AC
D	0.745	0.765	18.92	19.43	16	AA
D	0.885	0.915	22.48	23.24	18	AD
D	1.015	1.045	25.78	26.54	20	AE
D	1.14	1.265	28.96	32.13	24	AF
D	1.360	1.380	34.54	35.05	28	*5

- NOTES:
1. D&E DO NOT INCLUDE MOLD FLASH
 2. MOLD FLASH OR PROTRUSIONS NOT TO EXCEED .15mm (.006")
 3. CONTROLLING DIMENSION: MILLIMETER
 4. MEETS JEDEC MS001-XX AS SHOWN IN ABOVE TABLE
 5. SIMILIAR TO JEDEC MO-058AB
 6. N = NUMBER OF PINS

 <small>120 SAN GABRIEL DR. SUNNYVALE CA 94086 FAX (415) 737 7194</small> <small>PROPRIETARY INFORMATION</small>	PACKAGE FAMILY OUTLINE: PDIP .300"		21-0043 D

Quad SPST CMOS Analog Switches

Package Information (continued)

(The package drawing(s) in this data sheet may not reflect the most current specifications. For the latest package outline information, go to www.maxim-ic.com/packages.)

DG202/DG212

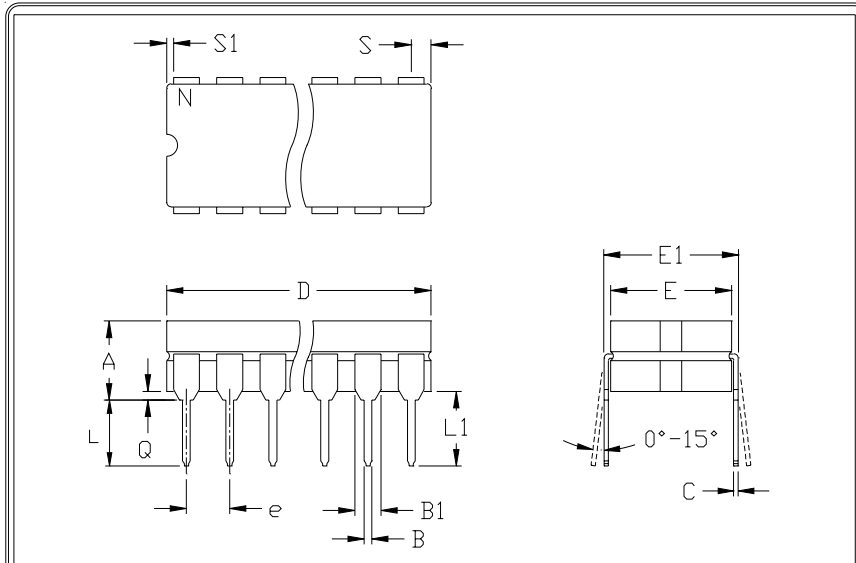

	INCHES		MILLIMETERS	
	MIN	MAX	MIN	MAX
A	---	0.200	---	5.08
B	0.014	0.023	0.36	0.58
B1	0.038	0.065	0.97	1.65
C	0.008	0.015	0.20	0.38
E	0.220	0.310	5.59	7.87
E1	0.290	0.320	7.37	8.13
e	0.100		2.54	
L	0.125	0.200	3.18	5.08
L1	0.150	---	0.00	---
Q	0.015	0.070	0.38	1.78
S	---	0.098	---	2.49
S1	0.005	---	0.13	---

	INCHES		MILLIMETERS		N	CASE
	MIN	MAX	MIN	MAX		
D	---	0.405	---	10.29	8	P:D4
D	---	0.785	---	19.94	14	C:D1
D	---	0.840	---	21.34	16	E:D2
D	---	0.960	---	24.38	18	V:D6
D	---	1.060	---	26.92	20	R:D8
D	---	1.280	---	32.51	24	L:D9

- NOTES:
 1. CONTROLLING DIMENSION: INCH
 2. MEETS 1835 CASE OUTLINE CONFIGURATION #1 AS SHOWN IN ABOVE TABLE
 3. N = NUMBER OF PINS



PACKAGE FAMILY OUTLINE: CDIP .300"

1/1

21-0045 A
 DOCUMENT CONTROL NUMBER REV.

Quad SPST CMOS Analog Switches

Package Information (continued)

(The package drawing(s) in this data sheet may not reflect the most current specifications. For the latest package outline information, go to www.maxim-ic.com/packages.)

Symbol	COMMON DIMENSIONS			
	MILLIMETERS		INCHES	
	MIN.	MAX.	MIN.	MAX.
A	—	1.10	—	.043
A ₁	0.05	0.15	.002	.006
A ₂	0.85	0.95	.033	.037
b	0.19	0.30	.007	.012
b ₁	0.19	0.25	.007	.010
c	0.09	0.20	.004	.008
c ₁	0.09	0.14	.004	.006
D	SEE VARIATIONS		SEE VARIATIONS	
E	4.30	4.50	.169	.177
e	0.65 BSC .026 BSC			
H	6.25	6.55	.246	.258
L	0.50	0.70	.020	.028
N	SEE VARIATIONS		SEE VARIATIONS	
α	0°	8°	0°	8°

JEDEC	N	VARIATIONS				
		MILLIMETERS		INCHES		
		MIN.	MAX.	MIN.	MAX.	
MD-153						
AB-1	14	D	4.90	5.10	.193	.201
AB	16	D	4.90	5.10	.193	.201
AC	20	D	6.40	6.60	.252	.260
AD	24	D	7.70	7.90	.303	.311
AE	28	D	9.60	9.80	.378	.386

NOTES:
 1. DIMENSIONS D AND E DO NOT INCLUDE FLASH
 2. MOLD FLASH OR PROTRUSIONS NOT TO EXCEED 0.15mm PER SIDE
 3. CONTROLLING DIMENSION: MILLIMETER
 4. MEETS JEDEC OUTLINE MD-153. SEE JEDEC VARIATIONS TABLE
 5. "N" REFERS TO NUMBER OF LEADS
 6. THE LEAD TIPS MUST LIE WITHIN A SPECIFIED ZONE. THIS TOLERANCE ZONE IS DEFINED BY TWO PARALLEL PLANES. ONE PLANE IS THE SEATING PLANE, DATUM [-C-]; THE OTHER PLANE IS AT THE SPECIFIED DISTANCE FROM [-C-] IN THE DIRECTION INDICATED

-DRAWING NOT TO SCALE-

TSSOP4.40mm.EPS

DALLAS SEMICONDUCTOR **MAXIM**

TITLE:
PACKAGE OUTLINE, TSSOP 4.40mm BODY

APPROVAL	DOCUMENT CONTROL NO. 21-0066	REV. G	1/1
----------	---------------------------------	-----------	-----

Quad SPST CMOS Analog Switches

Package Information (continued)

(The package drawing(s) in this data sheet may not reflect the most current specifications. For the latest package outline information, go to www.maxim-ic.com/packages.)

DG202/DG212

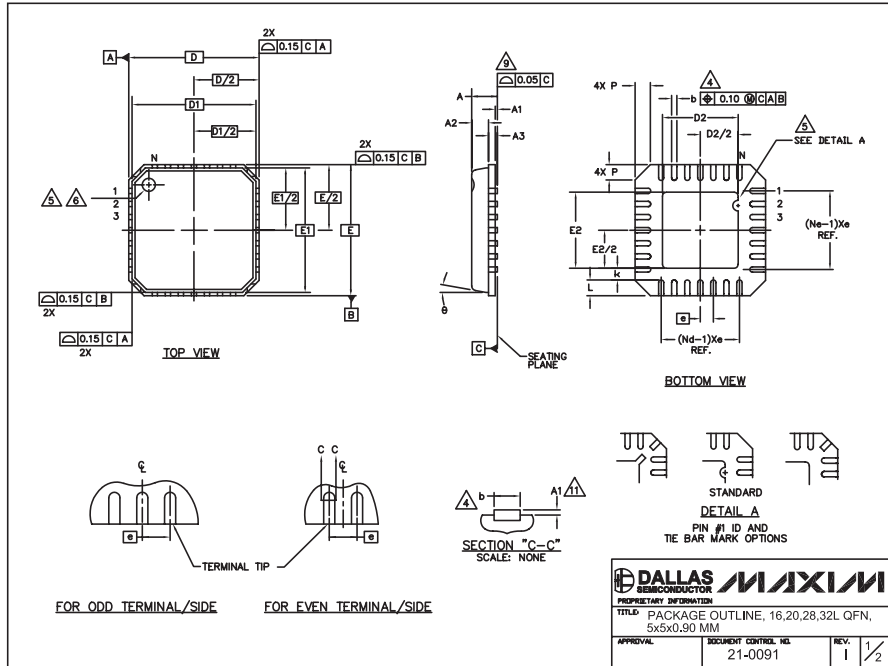

COMMON DIMENSIONS												
PKG	16L 5x5			20L 5x5			28L 5x5			32L 5x5		
SYMBOL	MIN.	NOM.	MAX.	MIN.	NOM.	MAX.	MIN.	NOM.	MAX.	MIN.	NOM.	MAX.
A	0.80	0.90	1.00	0.80	0.90	1.00	0.80	0.90	1.00	0.80	0.90	1.00
A1	0.00	0.01	0.05	0.00	0.01	0.05	0.00	0.01	0.05	0.00	0.01	0.05
A2	0.00	0.65	1.00	0.00	0.65	1.00	0.00	0.65	1.00	0.00	0.65	1.00
A3	0.20 REF			0.20 REF			0.20 REF			0.20 REF		
b	0.28	0.33	0.40	0.23	0.28	0.35	0.18	0.23	0.30	0.18	0.23	0.30
D	4.90	5.00	5.10	4.90	5.00	5.10	4.90	5.00	5.10	4.90	5.00	5.10
D1	4.75 BSC			4.75 BSC			4.75 BSC			4.75 BSC		
E	4.90	5.00	5.10	4.90	5.00	5.10	4.90	5.00	5.10	4.90	5.00	5.10
E1	4.75 BSC			4.75 BSC			4.75 BSC			4.75 BSC		
e	0.80 BSC			0.65 BSC			0.50 BSC			0.50 BSC		
k	0.25	-	-	0.25	-	-	0.25	-	-	0.25	-	-
L	0.35	0.55	0.75	0.35	0.55	0.75	0.35	0.55	0.75	0.30	0.40	0.50
N	16			20			28			32		
ND	4			5			7			8		
NE	4			5			7			8		
P	0.00	0.42	0.60	0.00	0.42	0.60	0.00	0.42	0.60	0.00	0.42	0.60
ϕ	0"			12"			0"			12"		

EXPOSED PAD VARIATIONS						
PKG CODES	D2			E2		
	MIN.	NOM.	MAX.	MIN.	NOM.	MAX.
G1655-3	2.95	3.10	3.25	2.95	3.10	3.25
G2055-1	2.55	2.70	2.85	2.55	2.70	2.85
G2055-2	2.95	3.10	3.25	2.95	3.10	3.25
G2855-1	2.55	2.70	2.85	2.55	2.70	2.85
G2855-2	2.95	3.10	3.25	2.95	3.10	3.25
G3255-1	2.95	3.10	3.25	2.95	3.10	3.25

NOTES:

- DIE THICKNESS ALLOWABLE IS 0.305mm MAXIMUM (.012 INCHES MAXIMUM)
- DIMENSIONING & TOLERANCES CONFORM TO ASME Y14.5M - 1994.
- N IS THE NUMBER OF TERMINALS.
Nd IS THE NUMBER OF TERMINALS IN X-DIRECTION & Ne IS THE NUMBER OF TERMINALS IN Y-DIRECTION.
- DIMENSION b APPLIES TO PLATED TERMINAL AND IS MEASURED BETWEEN 0.20 AND 0.25mm FROM TERMINAL TIP.
- THE PIN #1 IDENTIFIER MUST BE EXISTED ON THE TOP SURFACE OF THE PACKAGE BY USING INDENTATION MARK OR INK/LASER MARKED. DETAILS OF PIN #1 IDENTIFIER IS OPTIONAL, BUT MUST BE LOCATED WITHIN ZONE INDICATED.
- EXACT SHAPE AND SIZE OF THIS FEATURE IS OPTIONAL.
- ALL DIMENSIONS ARE IN MILLIMETERS.
- PACKAGE WARPAGE MAX 0.05mm.
- APPLIED FOR EXPOSED PAD AND TERMINALS. EXCLUDE EMBEDDED PART OF EXPOSED PAD FROM MEASURING.
- MEETS JEDEC MO220; EXCEPT DIMENSION "b".
- APPLIED FOR EXPOSED PAD AND TERMINALS. EXCLUDE EMBEDDING PART OF EXPOSED PAD FROM MEASURING.
- THIS PACKAGE OUTLINE APPLIES TO ANVIL SINGULATION (STEPPED SIDES).

DALLAS MAXIM SEMICONDUCTOR
 PROPRIETARY INFORMATION
 TITLE: PACKAGE OUTLINE, 16,20,28,32L QFN, 5x5x0.90 MM
 APPROVAL: DOCUMENT CONTROL NO. 21-0091 REV. I 2/2



WHAT'S NEW

PRODUCTS

SOLUTIONS

DESIGN

APPNOTES

SUPPORT

BUY

COMPANY

DG202

Part Number Table

Notes:

1. See the [DG202 QuickView Data Sheet](#) for further information on this product family or download [full data sheet](#) (PDF, 1.3MB).
2. Other options and links for purchasing parts are listed at: <http://www.maxim-ic.com/sales>.
3. [Didn't Find What You Need?](#) Ask our applications engineers. Expert assistance in finding parts, usually within one business day.
4. Part number suffixes: T or T&R = tape and reel; + = RoHS/lead-free; # = RoHS/lead-exempt. See [full data sheet](#) or [Part Naming Conventions](#).
5. * Some packages have variations, listed on the drawing. "PkgCode/Variation" tells which variation the product uses.

Part Number	Free Sample	Buy Direct	Package: TYPE PINS SIZE DRAWING CODE/VAR *	Temp	RoHS/Lead-Free Material
DG202CK	<input type="checkbox"/>	<input type="checkbox"/>	Ceramic DIP;16 pin;.300" Dwg: 21-0045A (PDF) Use pkgcode/variation: J16-3*	0C to +70C	RoHS/Lead-Free Material
DG202AK	<input type="checkbox"/>	<input type="checkbox"/>	Ceramic DIP;16 pin;.300" Dwg: 21-0045A (PDF) Use pkgcode/variation: J16-3*	-55C to +125C	RoHS/Lead-Free Material
DG202AK/883B	<input type="checkbox"/>	<input type="checkbox"/>	Ceramic DIP;16 pin;.300" Dwg: 21-0045A (PDF) Use pkgcode/variation: J16-3*	-55C to +125C	RoHS/Lead-Free Material
DG202AK/HR	<input type="checkbox"/>	<input type="checkbox"/>	Ceramic DIP;16 pin;.300" Dwg: 21-0045A (PDF) Use pkgcode/variation: J16-3*	-55C to +125C	RoHS/Lead-Free Material
DG202BK	<input type="checkbox"/>	<input type="checkbox"/>	Ceramic DIP;16 pin;.300" Dwg: 21-0045A (PDF) Use pkgcode/variation: J16-3*	-55C to +125C	RoHS/Lead-Free Material
DG202C/D	<input type="checkbox"/>	<input type="checkbox"/>			RoHS/Lead-Free Material
DG202CJ+	<input type="checkbox"/>	<input type="checkbox"/>	PDIP;16 pin;.300" Dwg: 21-0043D (PDF) Use pkgcode/variation: P16+1*	0C to +70C	RoHS/Lead-Free Material

DG202CJ-2				0C to +70C	RoHS/Le
DG202CJ			PDIP;16 pin;.300" Dwg: 21-0043D (PDF) Use pkgcode/variation: P16-1*	0C to +70C	RoHS/Le Material
DG202DJ			PDIP;16 pin;.300" Dwg: 21-0043D (PDF) Use pkgcode/variation: P16-1*	-40C to +85C	RoHS/Le Material
DG202CSE+			SOIC;16 pin;.150" Dwg: 21-0041B (PDF) Use pkgcode/variation: S16+2*	0C to +70C	RoHS/Le Material
DG202CSE+T			SOIC;16 pin;.150" Dwg: 21-0041B (PDF) Use pkgcode/variation: S16+2*	0C to +70C	RoHS/Le Material
DG202CSE-T			SOIC;16 pin;.150" Dwg: 21-0041B (PDF) Use pkgcode/variation: S16-2*	0C to +70C	RoHS/Le Material
DG202CSE			SOIC;16 pin;.150" Dwg: 21-0041B (PDF) Use pkgcode/variation: S16-2*	0C to +70C	RoHS/Le Material
DG202DY			SOIC;16 pin;.150" Dwg: 21-0041B (PDF) Use pkgcode/variation: S16-2*	-40C to +85C	RoHS/Le Material
DG202DY-T			SOIC;16 pin;.150" Dwg: 21-0041B (PDF) Use pkgcode/variation: S16-2*	-40C to +85C	RoHS/Le Material
DG202BSE			SOIC;16 pin;.150" Dwg: 21-0041B (PDF) Use pkgcode/variation: S16-2*	-40C to +85C	RoHS/Le Material
DG202DY+			SOIC;16 pin;.150" Dwg: 21-0041B (PDF) Use pkgcode/variation: S16+2*	-40C to +85C	RoHS/Le Material
DG202DY+T				-40C to +85C	RoHS/Le

[Didn't Find What You Need?](#)

[CONTACT US: SEND US AN EMAIL](#)

X-ON Electronics

Largest Supplier of Electrical and Electronic Components

Click to view similar products for [Analogue Switch ICs category](#):

Click to view products by [Maxim manufacturer](#):

Other Similar products are found below :

[FSA3051TMX](#) [NLVAS4599DTT1G](#) [MAX4992EVB+T](#) [MAX4684ETB+T](#) [BCM6522IPBG](#) [BCM65300IFSBG](#) [MAX14764ETA+T](#)
[TMUX1113RSVR](#) [TMUX1112RSVR](#) [ADG1436TRUZ-EP](#) [BL4684C](#) [PE423422A](#) [PE42359SCAA](#) [PE42540F](#) [RS550YUCM12](#)
[ADGS1414DBCCZ](#) [ADG658YRUZ-REEL7](#) [RS2117YUTQK10](#) [RS2118YUTQK10](#) [RS2227XUTQK10](#) [SP2526A-1EN-L/TR](#) [FSA4157P6X](#)
[BA7603F-E2](#) [MAX4702EUE+](#) [MAX4617CUE+](#) [MAX4599EUT+T](#) [MAX4066ESD+](#) [MAX4052ACSE+](#) [MAX396CAI+](#) [MAX391CPE+](#)
[MAX4730EXT+T](#) [MAX314CPE+](#) [MAX4051AEEE+](#) [BU4066BCFV-E2](#) [MAX313CPE+](#) [BU4S66G2-TR](#) [TS3A4751PWR](#)
[NCN1154MUTAG](#) [DG444DY-E3](#) [NLAS4157DFT2G](#) [NLAS4599DFT2G](#) [NLAS7242MUTBG](#) [NLASB3157DFT2G](#) [NLAST4599DFT2G](#)
[NLAST4599DTT1G](#) [DG403DY-T1-E3](#) [MAX4714EXTT](#) [MAX392CPE](#) [BGSX22G2A10E6327XTSA1](#) [ADG1611BRUZ-REEL7](#)