

Freedom Series



2

## Contents

<i>Description</i>	<i>Page</i>
Technical Data and Specifications	
Standards and Certifications . . . . .	<b>V5-T2-3</b>
Catalog Number Selection . . . . .	<b>V5-T2-3</b>
Contactors—Non-Reversing and Reversing . . . . .	<b>V5-T2-4</b>
Starters—Three-Phase Non-Reversing and Reversing, Full Voltage . . . . .	<b>V5-T2-10</b>
Starters—Single-Phase Non-Reversing, Full Voltage, Bi-Metallic Overload . . . . .	<b>V5-T2-15</b>
Accessories. . . . .	<b>V5-T2-21</b>
Renewal Parts . . . . .	<b>V5-T2-30</b>
Technical Data and Specifications. . . . .	<b>V5-T2-34</b>
Relays—Thermal Overload . . . . .	<b>V5-T2-38</b>
C440/ <i>XT</i> Electronic Overload Relay . . . . .	<b>V5-T2-48</b>

### Product Overview

Freedom Series starters and contactors feature a compact, space-saving design, using state-of-the-art technology and the latest in high strength, impact and temperature resistant insulating materials.

### Features, Benefits and Functions

#### Freedom NEMA

- Adjustable bimetallic ambient compensated overload relays with interchangeable heater packs—available in three basic sizes, covering applications up to 900 hp—reducing the number of different contactor/overload relay combinations that have to be stocked. Fixed heater overloads are optional
- Electronic overload relay (C440) available as a stand-alone unit and assembled with Freedom Contactor
- A full line of snap-on accessories— top and side mounted auxiliary contacts, solid-state and pneumatic timers, and so on
- Straight-through wiring— line lugs at top, load lugs at bottom
- Horizontal or vertical mounting on upright panel for application freedom
- Screw type power terminals have captive, backed-out self-lifting pressure plates with  $\pm$  screws—reduced wiring time
- Accessible terminals for easy wiring. Optional fingerproof shields available to prevent electrical shock
- Top located coil terminals convenient and readily accessible. 45 mm contactor magnet coils have three terminals, permitting either top or diagonal wiring—easy to replace European or U.S. style starters or contactors without changing wiring layout
- Designed to meet or exceed NEMA, UL, CSA, VDE, BS and other international standards and listings
- American engineering— built by Eaton, using the latest in statistical process control methods to produce high quality, reliable products
- Sized based on standard NEMA classifications
- Easy coil change and inspectable/replaceable contacts
- Available in open and NEMA Type 1, 3R, 4/4X and 12 enclosures

## Standards and Certifications

- Standard: designed to meet or exceed UL, NEMA, IEC, CSA, VDE and BS
- UL listed: UL File #E1491, Guide #NLDX—Open and NEMA 1, 4, 12 Enclosed
- CSA Certified: CSA File #LR353, Class #321104 Open and NEMA 1 Enclosed



### ISO 9000 Certification

When you turn to Eaton's products, you turn to quality. The International Standards Organization (ISO) has established a series of standards acknowledged by 91 industrialized nations to bring harmony to the international quest for quality. The ISO certification process covers 20 quality system elements in design, production and installation that must conform to achieve registration. This commitment to quality will result in increased product reliability and total customer satisfaction.

### Short Circuit Protection

**Fuses and Inverse-Time Circuit Breakers** may be selected per Article 430, Part D of the National Electrical Code to protect motor branch circuits from fault conditions. If higher ratings or settings are required to start the motor, do **not** exceed the maximum as listed in Exception No. 2, Article 430-52.

## Catalog Number Selection

### Freedom Series

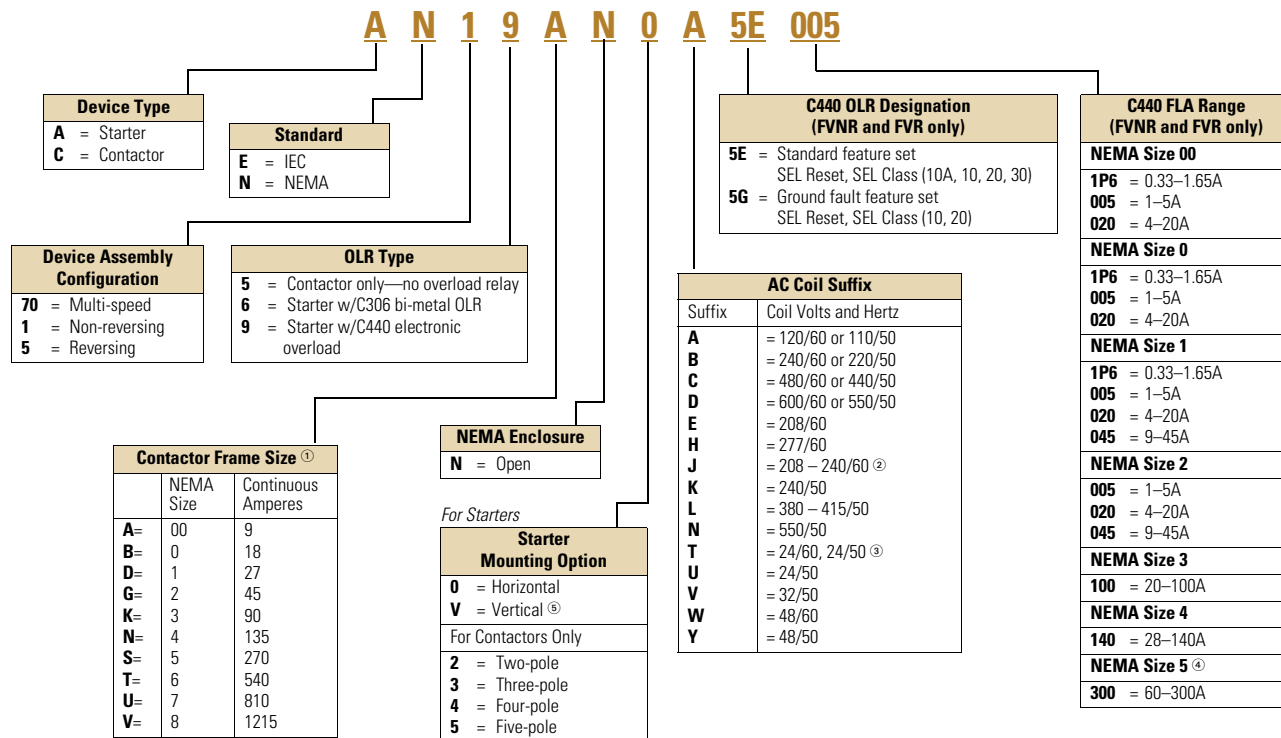

### Notes

- For contactor only orders, add **B** to end of catalog number if NEMA Size 00–2, 6.
- NEMA Sizes 00 and 0 only.
- NEMA Sizes 00 and 0 only. Sizes 1–8 are 24/60 only.
- NEMA Size 5 requires the use of CTs with 1-5A OL relay.
- Only available on AN56 reversing starters.

## Non-Reversing and Reversing Contactors

2

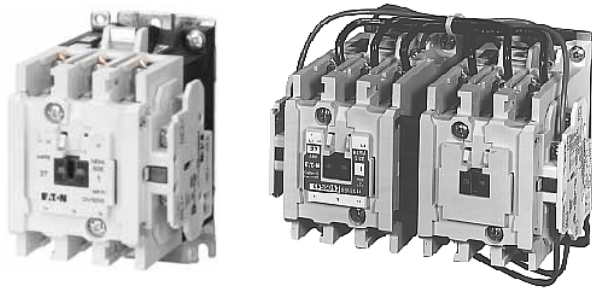

## Contactors—Non-Reversing and Reversing

## Product Description

**Non-Reversing**

Contactors are most commonly used to switch motor loads in applications where running overcurrent protection is either not required or is provided separately. Contactors consist of a magnetically actuated switch which can be remotely operated by a pushbutton station or pilot device such as a proximity switch, limit switch, float switch, auxiliary contacts, and so on.

**Reversing**

Reversing contactors are used primarily for reversing single- or three-phase motors in applications where running overcurrent protection is either not required or is provided separately. They consist of two contactors mechanically and electrically interlocked to prevent line shorts and energization of both contactors simultaneously.

## Contents

<b>Description</b>	<b>Page</b>
Contactors—Non-Reversing and Reversing	
Product Selection . . . . .	V5-T2-5
Kits and Accessories . . . . .	V5-T2-6
Renewal Parts Publication Numbers . . . . .	V5-T2-6
Technical Data and Specifications . . . . .	V5-T2-7
Dimensions . . . . .	V5-T2-8
Starters—Three-Phase Non-Reversing and Reversing, Full Voltage . . . . .	V5-T2-10
Starters—Single-Phase Non-Reversing, Full Voltage, Bi-Metallic Overload . . . . .	V5-T2-15
Accessories . . . . .	V5-T2-21
Renewal Parts . . . . .	V5-T2-30
Technical Data and Specifications . . . . .	V5-T2-34
Relays—Thermal Overload . . . . .	V5-T2-38

## Features, Benefits and Functions

- Designed specifically for use in applications requiring NEMA ratings. Contactors meet or exceed NEMA standards ICS 2-1993
- Long life twin break, silver cadmium oxide contacts—provide excellent conductivity and superior resistance to welding and arc erosion
- Designed to 3,000,000 electrical operations at maximum hp ratings up through 25 hp at 600V
- Steel mounting plate standard on all open type contactors

**Non-Reversing**

- Holding circuit contact(s) supplied as standard:
  - Sizes 00–3 have NO auxiliary contact block mounted on right hand side (on Size 00, contact occupies 4th power pole position—no increase in width)
  - Sizes 4–5 have a NO contact block mounted on left side
  - Sizes 6–7 have a 2NO/2NC contact block on top left
  - Size 8 has a NO/NC contact block on top left back and a NO contact block on top right back

**Reversing**

- One NO-NC side mounted interlock supplied as standard on each contactor for Sizes 00–8

## Product Selection

### Three-Pole Contactors

**NEMA Size 00  
CN55AN3AB**



**NEMA Size 0  
CN15BN3AB**



**NEMA Size 3  
CN15KN3A**



### Type CN15/CN55 NEMA Contactors—Non-Reversing and Reversing

NEMA Size	Continuous Ampere Rating	Maximum UL Horsepower <sup>①</sup>						Non-Reversing Catalog Number	Reversing Catalog Number
		Single-Phase		Three-Phase		480V	600V		
		115V	230V	208V	240V				
00	9	1/3	1	1-1/2	1-1/2	2	2	CN15AN3_B	CN55AN3_B
0	18	1	2	3	3	5	5	CN15BN3_B	CN55BN3_B
1	27	2	3	7-1/2	7-1/2	10	10	CN15DN3_B	CN55DN3_B
2	45	3	7-1/2	10	15	25	25	CN15GN3_B	CN55GN3_B
3	90			25	30	50	50	CN15KN3_	CN55KN3_
4	135			40	50	100	100	CN15NN3_	CN55NN3_
5	270			75	100	200	200	CN15SN3_	CN55SN3_
6	540			150	200	400	400	CN15TN3_B	CN55TN3_B
7	810			200	300	600	600	CN15UN3_	CN55UN3_
8 <sup>②</sup>	1215			400	450	900	900	CN15VN3_	CN55VN3_

### Magnet Coils—AC and DC

Contactors listed in this section also have a 50 Hz rating as shown in the adjacent table. Select required contactor by catalog number and replace the magnet coil alpha

designation in the catalog number ( ) with the proper code suffix from the table.

For Sizes 00–2, the magnet coil alpha designation will be the next to the last digit of the listed catalog number.

EXAMPLE: For a 380V, 50 Hz coil, change CN15AN3\_B to CN15AN3LB. For all other sizes, the magnet coil alpha designation will be the last digit of the listed catalog number.

For **DC Magnet Coils**, see Accessories, **Pages V5-T2-28 and V5-T2-29**.

### AC Suffix

Coil Volts and Hertz	Code Suffix
120/60 or 110/50	<b>A</b>
240/60 or 220/50	<b>B</b>
480/60 or 440/50	<b>C</b>
600/60 or 550/50	<b>D</b>
208/60	<b>E</b>
277/60	<b>H</b>
208–240/60 <sup>③</sup>	<b>J</b>
240/50	<b>K</b>

Coil Volts and Hertz	Code Suffix
380–415/50	<b>L</b>
550/50	<b>N</b>
24/60, 24/50 <sup>④</sup>	<b>T</b>
24/50	<b>U</b>
32/50	<b>V</b>
48/60	<b>W</b>
48/50	<b>Y</b>

### Notes

- ① Maximum horsepower rating of starters for 380V 50 Hz applications:
- | NEMA Size  | 00    | 0 | 1  | 2  | 3  | 4  | 5   | 6   | 7   | 8   |
|------------|-------|---|----|----|----|----|-----|-----|-----|-----|
| Horsepower | 1-1/2 | 5 | 10 | 25 | 50 | 75 | 150 | 300 | 600 | 900 |
- ② Common control. For separate 120V control, insert letter **D** in 7th position of listed catalog number. Example: CN15VND3C.
  - ③ NEMA Sizes 00 and 0 only.
  - ④ NEMA Sizes 00 and 0 only. Sizes 1–8 are 24/60 only.

# 2.1

## NEMA Contactors and Starters

### Freedom Series

#### Two-, Four- and Five-Pole Contactors

2

NEMA Size 2  
Five-Pole Contactor  
CN15GN5AB



#### Type CN15 NEMA Contactors—Non-Reversing

NEMA Size	Continuous Ampere Rating	Maximum UL Horsepower Single-Phase (Two-Pole)		Three-Phase				Two-Pole Non-Reversing	Four-Pole Non-Reversing	Five-Pole Non-Reversing
		115V	230V	208V	240V	480V	600V	Catalog Number	Catalog Number	Catalog Number
00	9	1/3	1	1-1/2	1-1/2	2	2	CN15AN2_B	CN15AN4_B	—
0	18	1	2	2	3	5	5	CN15BN2_B	—	—
1	27	2	3	7-1/2	7-1/2	10	10	CN15DN2_B	CN15DN4_B	CN15DN5_B
2	45	3	7-1/2	10	15	25	25	CN15GN2_B	CN15GN4_B	CN15GN5_B
3	90			25	30	50	50	CN15KN2_	—	—
4	135			40	50	100	100	CN15NN2_	—	—
5	270			75	100	200	200	CN15SN2_	—	—
6	540			150	200	400	400	CN15TN2_B	—	—

#### Magnet Coils—AC and DC

Select required starter by catalog number and replace the magnet coil alpha designation in the catalog number ( ) with the proper code suffix from the table.

For Sizes 00–2, the magnet coil alpha designation will be the next to the last digit of the listed catalog number. EXAMPLE: For a 380V, 50 Hz coil, change CN15BN3\_B

to CN15BN3LB. For all other sizes, the magnet coil alpha designation will be the last digit of the listed catalog number.

For **DC Magnet Coils**, see Accessories, **Pages V5-T2-28 and V5-T2-29**.

#### AC Suffix

Coil Volts and Hertz	Code Suffix
120/60 or 110/50	<b>A</b>
240/60 or 220/50	<b>B</b>
480/60 or 440/50	<b>C</b>
600/60 or 550/50	<b>D</b>
208/60	<b>E</b>
277/60	<b>H</b>
208–240/60 ①	<b>J</b>
240/50	<b>K</b>

Coil Volts and Hertz	Code Suffix
380–415/50	<b>L</b>
550/50	<b>N</b>
24/60, 24/50 ②	<b>T</b>
24/50	<b>U</b>
32/50	<b>V</b>
48/60	<b>W</b>
48/50	<b>Y</b>

#### Kits and Accessories

- Auxiliary contacts, contactor mounted—**Pages V5-T2-25 to V5-T2-27**
- Transient suppressor, for magnet coil—**Page V5-T2-24**
- Timers—solid-state and pneumatic, mount on contactor—**Page V5-T2-22**

#### Publication Numbers

- See **Page V5-T2-30**

#### Renewal Parts

##### Notes

- ① NEMA Sizes 00 and 0 only.
- ② NEMA Sizes 00 and 0 only. Sizes 1–8 are 24/60 only.

## Technical Data and Specifications

### Wire (75°C) Sizes—AWG or kcmil—Open and Enclosed

NEMA Size	Power Terminals Line or Load	Control Terminals Cu Only
00	12–16 stranded; 12–14 solid Cu	12–16 stranded
0	8–16 stranded; 10–14 solid Cu	12–14 solid
1	8–14 stranded or solid Cu	
2	3–14 (upper) and/or 6–14 (lower) stranded or solid <sup>①</sup> Cu	
3	1/0–14 Cu/Al	
4	250 mcm–6	
5	750 kcmil–2, or (2) 250 kcmil–3/0 Cu/Al	
6	(2) 750 kcmil–3/0 Cu/Al	
7	(3) 750 kcmil–3/0 Cu/Al	
8	(4) 750 kcmil–4/0 Cu/Al	

### Plugging and Jogging Service Horsepower Ratings <sup>②</sup>

NEMA Size	200V	230V	460V	575V
00	—	1/2	1/2	1/2
0	1-1/2	1-1/2	2	2
1	3	3	5	5
2	7-1/2	10	15	15
3	15	20	30	30
4	25	30	60	60
5	60	75	150	150
6	125	150	300	300

#### Notes

<sup>①</sup> Two compartment box lug.

<sup>②</sup> Maximum horsepower where operation is interrupted more than 5 times per minute or more than 10 times in a 10 minute period.  
NEMA standard ICS 2-1993 table 2-4-3.

# 2.1

## NEMA Contactors and Starters

### Freedom Series

#### Dimensions

Approximate Dimensions in Inches (mm)

2

#### Non-Reversing Contactors—Open Type

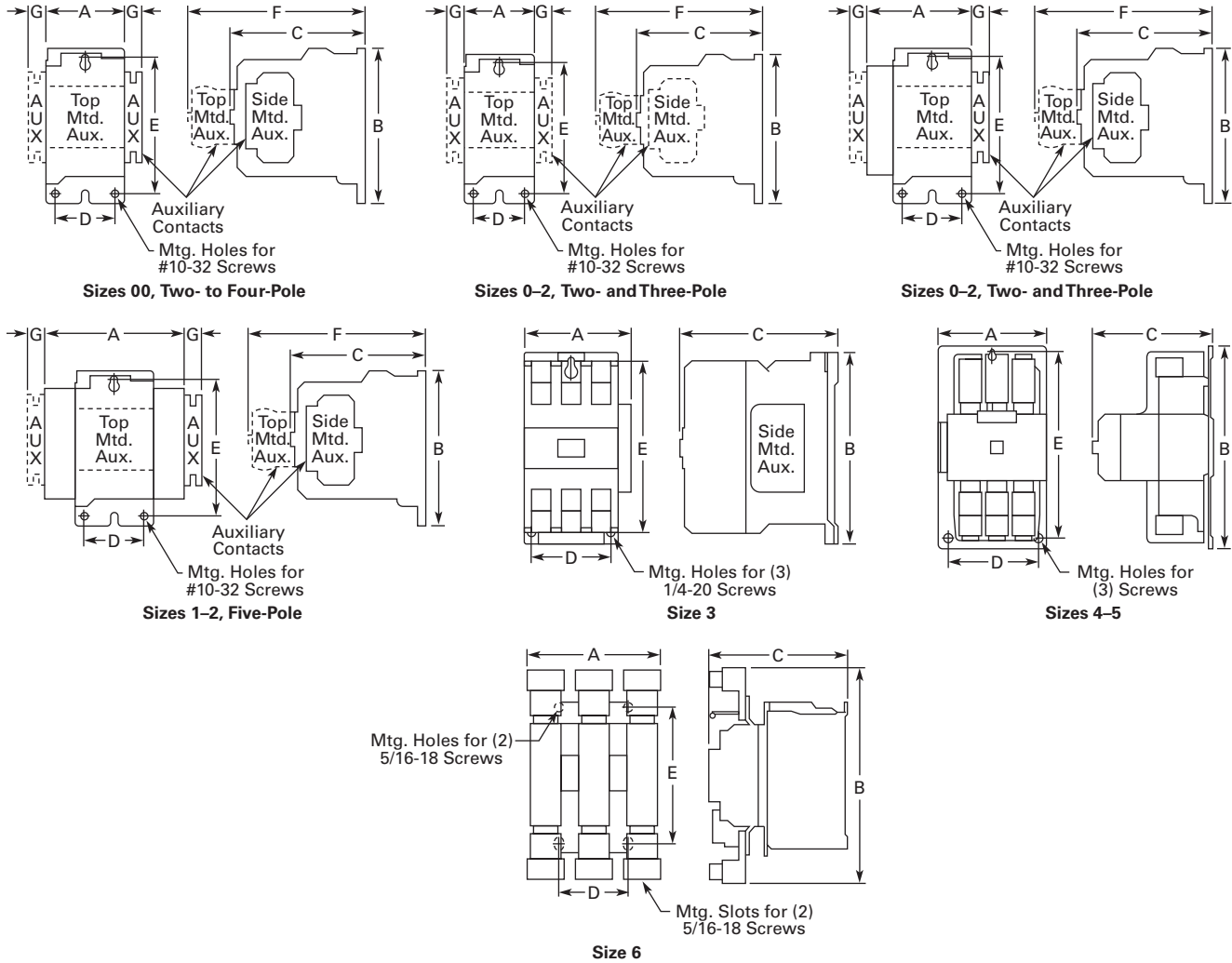

#### Dimensions and Shipping Weights

NEMA Size	Number of Poles	Wide A	High B	Deep C	Mounting D	Mounting E	F	G	Shipping Weight Lbs (kg)
00	2-4	1.75 (44.5)	3.88 (98.6)	3.49 (88.6)	1.50 (38.1) ①	3.38 (85.9)	4.62 (117.3)	0.54 (13.7)	1.7 (0.7)
0	2-3	1.75 (44.5)	3.88 (98.6)	3.49 (88.6)	1.50 (38.1) ①	3.38 (85.9)	4.62 (117.3)	0.54 (13.7)	1.8 (0.8)
1-2	2-3	2.56 (65.0)	5.05 (128.3)	4.44 (112.8)	2.00 (50.8) ①	4.50 (114.3)	5.80 (147.3)	0.54 (13.7)	3.1 (1.4)
1-2	4	3.44 (87.4)	5.05 (128.3)	4.44 (112.8)	2.00 (50.8) ①	4.50 (114.3)	5.80 (147.3)	0.54 (13.7)	3.6 (1.6)
1-2	5	4.32 (109.7)	5.05 (128.3)	4.44 (112.8)	2.00 (50.8) ①	4.50 (114.3)	5.80 (147.3)	0.54 (13.7)	4.0 (1.8)
3	2-3	4.08 (103.6)	7.17 (182.1)	5.94 (150.9)	3.00 (76.2)	6.63 (168.4)	—	—	8.5 (3.9)
4	2-3	7.05 (179.1)	9.11 (231.4)	7.25 (184.2)	6.00 (152.4)	8.50 (215.9)	—	—	20.0 (9.1)
5	2-3	7.05 (179.1)	13.12 (333.2)	7.78 (197.6)	6.00 (152.4)	12.50 (317.5)	—	—	23.0 (10.4)
6	3	8.63 (219.2)	13.54 (343.9)	8.88 (225.6)	4.33 (110.0)	8.63 (219.2)	—	—	35.0 (15.9)
7	3	11.02 (279.9)	19.30 (490.2)	11.46 (291.1)	6.89 (175.0)	11.02 (279.9)	—	—	100.0 (45.4)
8	3	13.00 (330.2)	24.50 (622.3)	13.63 (346.2)	4.22 (107.2)	14.86 (377.4)	—	—	160.0 (72.6)

#### Note

① Center mounting slot at bottom supplied only on Size 00 and 0 contactors.

Approximate Dimensions in Inches (mm)

### Reversing Contactors—Open Type

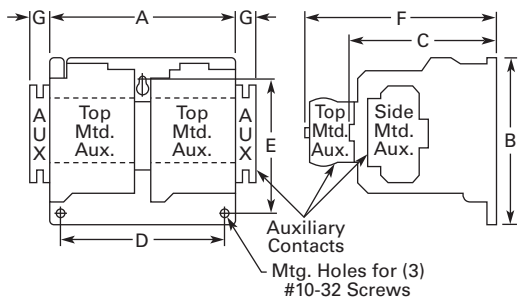

Sizes 00-2

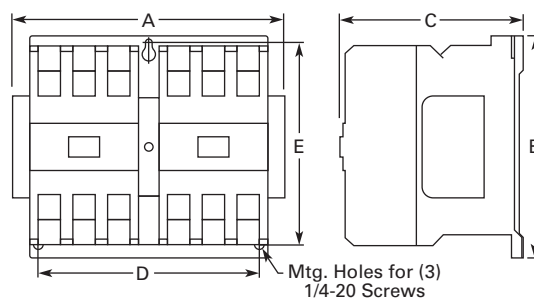

Size 3

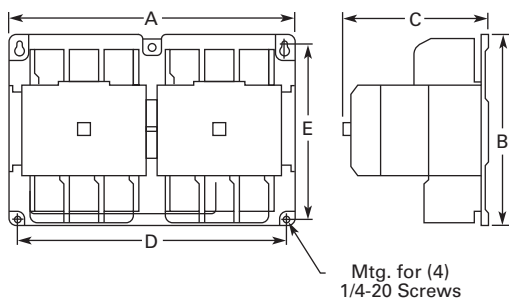

Sizes 4-5

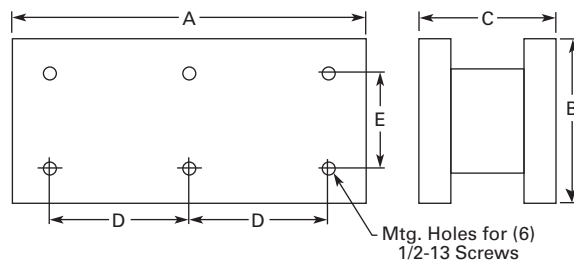

Open Type—Sizes 7-8 Horizontal

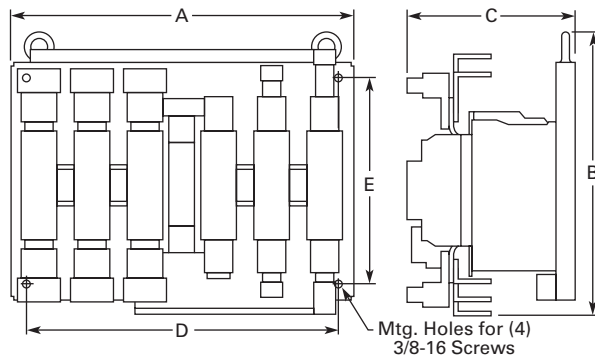

Size 6

### Dimensions and Shipping Weights

NEMA Size	Wide A	High B	Deep C	Mounting D	Mounting E	F	G	Shipping Weight Lbs (kg)
00-0	4.20 (106.7)	4.35 (110.5)	3.52 (89.4)	3.50 (88.9)	3.86 (98.0)	4.90 (124.5)	0.54 (13.7)	3.3 (1.5)
1-2	5.71 (145.0)	5.05 (128.3)	4.44 (112.8)	5.25 (133.4)	3.63 (92.2)	5.80 (147.3)	0.54 (13.7)	7.8 (3.5)
3	8.70 (221.0)	7.17 (182.1)	5.94 (150.9)	7.00 (177.8)	6.63 (168.4)	—	—	17.0 (7.7)
4	14.68 (372.9)	9.11 (231.4)	7.25 (184.2)	13.50 (342.9)	8.50 (215.9)	—	—	47.0 (21.3)
5	14.50 (368.3)	12.25 (311.2)	7.78 (197.6)	13.50 (342.9)	11.50 (292.1)	—	—	63.0 (28.6)
6	19.77 (502.2)	16.61 (421.9)	9.90 (251.5)	18.00 (457.2)	12.00 (304.8)	—	—	80.0 (36.3)
7	28.00 (711.2)	26.75 (679.5) ①	12.75 (323.9)	12.75 (323.9)	11.00 (279.4)	—	—	260.0 (118.0)
8	30.13 (765.3)	39.00 (990.6) ①	14.69 (373.1)	14.13 (358.9)	15.00 (381.0)	—	—	350.0 (158.9)

**Note**

① Includes cross wiring.



## Three-Phase Non-Reversing and Reversing, Full Voltage Starters

2

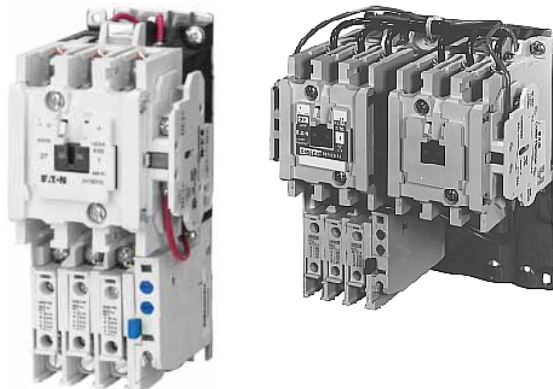

## Contents

<b>Description</b>	<b>Page</b>
Contactors—Non-Reversing and Reversing . . . . .	<b>V5-T2-4</b>
Starters—Three-Phase Non-Reversing and Reversing, Full Voltage	
Product Selection . . . . .	<b>V5-T2-11</b>
Kits and Accessories . . . . .	<b>V5-T2-13</b>
Renewal Parts Publication Numbers . . . . .	<b>V5-T2-13</b>
Technical Data and Specifications . . . . .	<b>V5-T2-13</b>
Wiring Diagrams . . . . .	<b>V5-T2-14</b>
Starters—Single-Phase Non-Reversing, Full Voltage, Bi-Metallic Overload . . . . .	<b>V5-T2-15</b>
Accessories . . . . .	<b>V5-T2-21</b>
Renewal Parts . . . . .	<b>V5-T2-30</b>
Technical Data and Specifications . . . . .	<b>V5-T2-34</b>
Relays—Thermal Overload . . . . .	<b>V5-T2-38</b>
C440/ <i>XT</i> Electronic Overload Relay . . . . .	<b>V5-T2-48</b>

## Starters—Three-Phase Non-Reversing and Reversing, Full Voltage

## Product Description

**Non-Reversing**

Three-phase, full voltage magnetic starters are most commonly used to switch AC motor loads. Starters consist of a magnetically actuated switch (contactor) and an overload relay assembled together.

**Reversing**

Three-phase, full voltage magnetic starters are used primarily for reversing of three-phase squirrel cage motors. They consist of two contactors and a single overload relay assembled together. The contactors are mechanically and electrically interlocked to prevent line shorts and energization of both contactors simultaneously.

## Features, Benefits and Functions

- Bimetallic ambient compensated overload relays—available in three basic sizes covering applications up to 900 hp—reducing number of different contactor/overload relay combinations that have to be stocked. These overload relays feature:
  - Selectable manual or automatic reset operation
  - Interchangeable heater packs adjustable  $\pm 24\%$  to match motor FLA and calibrated for 1.0 and 1.15 service factors. Heater packs for smaller overload relay will mount in larger overload relay—useful in derating applications such as jogging
  - Load lugs built into relay base
  - Single-phase protection, Class 20 or Class 10 trip time
  - Overload trip indication
  - Electrically isolated NO-NC contacts (pull RESET button to test)
- The C440 is a self-powered, robust electronic overload designed for integrated use with Freedom NEMA contactors
  - Tiered feature set to provide coverage specific to your application
  - Broad 5: 1 FLA range for maximum flexibility
  - Coverage from 0.05–1500A to meet all your needs
- Long life twin break, silver cadmium oxide contacts—provide excellent conductivity and superior resistance to welding and arc erosion. Generously sized for low resistance and cool operation
- Designed to 3,000,000 electrical operations at maximum hp ratings up through 25 hp at 600V
- Steel mounting plate standard on all open type starters
- Wired for separate or common control

**Non-Reversing**

- Holding circuit contact(s) supplied as standard:
  - Sizes 00–3 have a NO auxiliary contact block mounted on right-hand side (on Size 00, contact occupies 4th power pole position—no increase in width)
  - Sizes 4–5 have a NO contact block mounted on left side
  - Sizes 6–7 have a 2NO/2NC contact block on top left
  - Size 8 has a NO/NC contact block on top left back and a NO on top right back

**Reversing**

- Each contactor (Size 00–8) supplied with one NO-NC side mounted contact block as standard. NC contacts are wired as electrical interlocks

## Product Selection

### When Ordering Supply

- Catalog number
- Heater pack number (see selection table, **Pages V5-T2-40 to V5-T2-42**) or full load current

### Size 0 Non-Reversing Starter



### Size 1 Reversing Starter



### Type AN16/AN56 NEMA—Manual or Automatic Reset Overload Relay—Non-Reversing and Reversing <sup>①</sup>

NEMA Size	Continuous Ampere Rating	Service-Limit Current Rating (Amperes) <sup>④</sup>	Maximum UL Horsepower <sup>②</sup>						Three-Pole Non-Reversing <sup>③</sup> Catalog Number	Three-Pole Reversing <sup>③</sup> Catalog Number	Vertical Reversing <sup>③</sup> Catalog Number
			Single-Phase		Three-Phase						
			115V	230V	208V	240V	480V	600V			
00	9	11	1/3	1	1-1/2	1-1/2	2	2	AN16AN0_C	AN56AN0_C	—
0	18	21	1	2	3	3	5	5	AN16BN0_C	AN56BN0_C	AN56BNV0_
1	27	32	2	3	7-1/2	7-1/2	10	10	AN16DN0_B	AN56DN0_B	AN56DNV0_
2	45	52	3	7-1/2	10	15	25	25	AN16GN0_B	AN56GN0_B	AN56GNV0_
3	90	104	—	—	25	30	50	50	AN16KN0_	AN56KN0_	AN56KNV0_
4	135	156	—	—	40	50	100	100	AN16NN0_	AN56NN0_	AN56NNV0_
5	270	311	—	—	75	100	200	200	AN16SN0_B	AN56SN0_B	—
6	540	621	—	—	150	200	400	400	AN16TN0_C	AN56TN0_C	—
7	810	932	—	—	200	300	600	600	AN16UN0_B	AN56UN0_B	—
8 <sup>⑤</sup>	1215	1400	—	—	400	450	900	900	AN16VN0_B	AN56VN0_B	—

### Magnet Coils—AC or DC

Starter coils listed in this section also have a 50 Hz rating as shown in the adjacent table. Select required starter by catalog number and replace the magnet coil alpha designation

in the catalog number ( ) with the proper code suffix from the table.

For Sizes 00–2 and 5–8, the magnet coil alpha designation will be the next to last digit of the listed catalog number.

EXAMPLE: For a 380V, 50 Hz coil, change AN16BN0\_C to AN16BN0LC. For all other sizes, the magnet coil alpha designation will be the last digit of the listed catalog number.

For **DC Magnet Coils**, see Accessories, **Pages V5-T2-28 and V5-T2-29**.

### AC Suffix

Coil Volts and Hertz	Code Suffix
120/60 or 110/50	<b>A</b>
240/60 or 220/50	<b>B</b>
480/60 or 440/50	<b>C</b>
600/60 or 550/50	<b>D</b>
208/60	<b>E</b>
277/60	<b>H</b>
208–240/60 <sup>⑥</sup>	<b>J</b>
240/50	<b>K</b>

Coil Volts and Hertz	Code Suffix
380–415/50	<b>L</b>
550/50	<b>N</b>
24/60, 24/50 <sup>⑦</sup>	<b>T</b>
24/50	<b>U</b>
32/50	<b>V</b>
48/60	<b>W</b>
48/50	<b>Y</b>
48/50	<b>Y</b>

### Notes

- <sup>①</sup> Starter catalog numbers do not include heater packs. Select one carton of three heater packs. Heater pack selection, **Pages V5-T2-40 to V5-T2-42**.
- <sup>②</sup> Maximum horsepower rating of starters for 380V 50 Hz applications:

NEMA Size	00	0	1	2	3	4	5	6	7	8
Horsepower	1-1/2	5	10	25	50	75	150	300	600	900

- <sup>③</sup> Underscore ( ) indicates coil suffix required, see AC Suffix table.
- <sup>④</sup> The service-limit current ratings represent the maximum rms current, in amperes, which the controller shall be permitted to carry for protracted periods in normal service. At service-limit current ratings, temperature rises shall be permitted to exceed those obtained by testing the controller at its continuous current rating. The current rating of overload relays or trip current of other motor protective devices used shall not exceed the service-limit current rating of the controller.
- <sup>⑤</sup> Common control. For separate 120V control, insert letter **D** in 7th position of listed catalog number. Example: AN56VND0CB.
- <sup>⑥</sup> NEMA Sizes 00 and 0 only.
- <sup>⑦</sup> NEMA Sizes 00 and 0 only. Sizes 1–8 are 24/60 only.

# 2.1

## NEMA Contactors and Starters

### Freedom Series

#### Two-Speed Selective Control

##### When Ordering Supply

- Catalog number plus magnet coil code suffix. Example: Size 0—AN700BN022B
- Heater pack number or full load current for each speed

For two-speed other than selective control:

- Catalog number plus magnet coil code suffix and option required. Example: AN700BN022B except compelling
- Heater pack number or full load current for each speed

**Note:** Two-speed starters are designed for starting and controlling both separate (two-winding) and reconnectable (one-winding) motors. Separate winding, WYE-WYE motors have a separate winding for each speed. Reconnectable, consequent pole motors use the same winding for both speeds. All standard starters are wired for selective control.

##### Two-Winding AN700DN022



#### Separate Winding ①

Maximum Horsepower—60/50 Hertz

Constant or Variable Torque

Constant or Variable Torque				Constant Horsepower				NEMA Size	Open Type Catalog Number
115V	200V	230V	460V/575V	115V	200V	230V	460/575V		
1-1/2	3	3	5	1	2	2	3	0	AN700BN022_
3	7-1/2	7-1/2	10	2	5	5	7-1/2	1	AN700DN022_
—	10	15	25	—	7-1/2	10	20	2	AN700GN022_
—	25	30	50	—	20	25	40	3	AN700KN022_
—	40	50	100	—	30	40	75	4	AN700NN022_
—	75	100	200	—	60	75	150	5	AN700SN022_

Prices of starters do not include heater packs. Select two packs (two overload relays, one for each speed). Heater pack selection, Pages V5-T2-40 to V5-T2-42.

##### One-Winding AN700BN0218



#### Reconnectable Winding ①

Maximum Horsepower—60/50 Hertz

Constant or Variable Torque

Constant or Variable Torque				Constant Horsepower				NEMA Size	Open Type Constant or Variable Torque Catalog Number	Constant Horsepower Catalog Number
115V	200V	230V	460V/575V	115V	200V	230V	460/575V			
1-1/2	3	3	5	1	2	2	3	0	AN700BN0218_	AN700BN0219_
3	7-1/2	7-1/2	10	2	5	5	7-1/2	1	AN700DN0218_	AN700DN0219_
—	10	15	25	—	7-1/2	10	20	2	AN700GN0218_	AN700GN0219_
—	25	30	50	—	20	25	40	3	AN700KN0218_	AN700KN0219_
—	40	50	100	—	30	40	75	4	AN700NN0218_	AN700NN0219_

Prices of starters do not include heater packs. Select two packs (two overload relays, one for each speed). Heater pack selection, Pages V5-T2-40 to V5-T2-42.

##### One-Winding AN700DN0218



#### Magnetic Coils—AC or DC

Coil Voltage and Hz	Code Suffix	Coil Voltage and Hz	Code Suffix	Coil Voltage and Hz	Code Suffix
120/60 or 110/50	A	277/60	H	24/60, 24/50 ②	T
240/60 or 220/50	B	208–240/60	J	24/50	U
480/60 or 440/50	C	240/50	K	32/50	V
600/60 or 550/50	D	380–415/50	L	48/60	W
208/60	E	550/50	N	48/50	Y

##### Notes

① If branch circuit protective device is 45A or greater, C320FBR1 fuse kit(s) may be required for circuit protection per NEC 530-072.

② NEMA Sizes 00 and 0 only. Sizes 1–5 are 24/60 only.

### Kits and Accessories

- Auxiliary contacts, contactor mounted—**Pages V5-T2-25 to V5-T2-27**
- Transient suppressor, for magnet coil—**Page V5-T2-24**
- Timers—solid-state and pneumatic, mount on contactor—**Page V5-T2-22**

### Renewal Parts Publication Numbers

- See **Page V5-T2-30**

## Technical Data and Specifications

### Wire (75°C) Sizes—AWG or kcmil—NEMA Sizes 00–2—Open and Enclosed

NEMA Size	Wire Size <sup>①</sup> Cu Only
<b>Power Terminals—Line</b>	
00	12–16 AWG stranded, 12–14 AWG solid
0	8–16 AWG stranded, 10–14 AWG solid
1	8–14 AWG stranded or solid
2	3–14 AWG (upper) and/or 6–14 AWG (lower) stranded or solid <sup>②</sup>
<b>Power Terminals—Load—Cu Only (stranded or solid)</b>	
00–0	14–6 AWG stranded or solid
1–2	14–2 AWG stranded or solid
<b>Control Terminals—Cu Only</b>	
12–16 AWG stranded, 12–14 AWG solid	

### Wire (75°C) Sizes—AWG or kcmil—NEMA Sizes 3–8—Open and Enclosed

NEMA Size	Wire Size <sup>②</sup>
<b>Power Terminals—Line and Load</b>	
3	1/0–14 AWG Cu/Al
4	Open—3/0–8 AWG Cu; Enclosed—250 kcmil—6 AWG Cu/Al
5	750 kcmil—2 AWG; or (2) 250 kcmil—3/0 AWG Cu/Al
6	(2) 750 kcmil—3/0 AWG Cu/Al
7	(3) 750 kcmil—3/0 AWG Cu/Al
8	(4) 750 kcmil—1/0 AWG Cu/Al
<b>Control Terminals—Cu Only</b>	
12–16 AWG stranded, 12–14 AWG solid	

### Plugging and Jogging Service Horsepower Ratings <sup>③</sup>

NEMA Size	200V	230V	460V	575V
00	—	1/2	1/2	1/2
0	1-1/2	1-1/2	2	2
1	3	3	5	5
2	7-1/2	10	15	15
3	15	20	30	30
4	25	30	60	60
5	60	75	150	150
6	125	150	300	300

#### Notes

- <sup>①</sup> Minimum per NEC. Maximum wire size: Sizes 00 and 0 to 8 AWG and Sizes 1–2 to 2 AWG.
- <sup>②</sup> Two compartment box lug.
- <sup>③</sup> Maximum horsepower where operation is interrupted more than 5 times per minute, or more than 10 times in a 10 minute period. NEMA Standard ICS2-1993 table 2-4-3.

# 2.1

## NEMA Contactors and Starters

Freedom Series

### Wiring Diagrams

2

#### Three-Phase and Single-Phase Applications

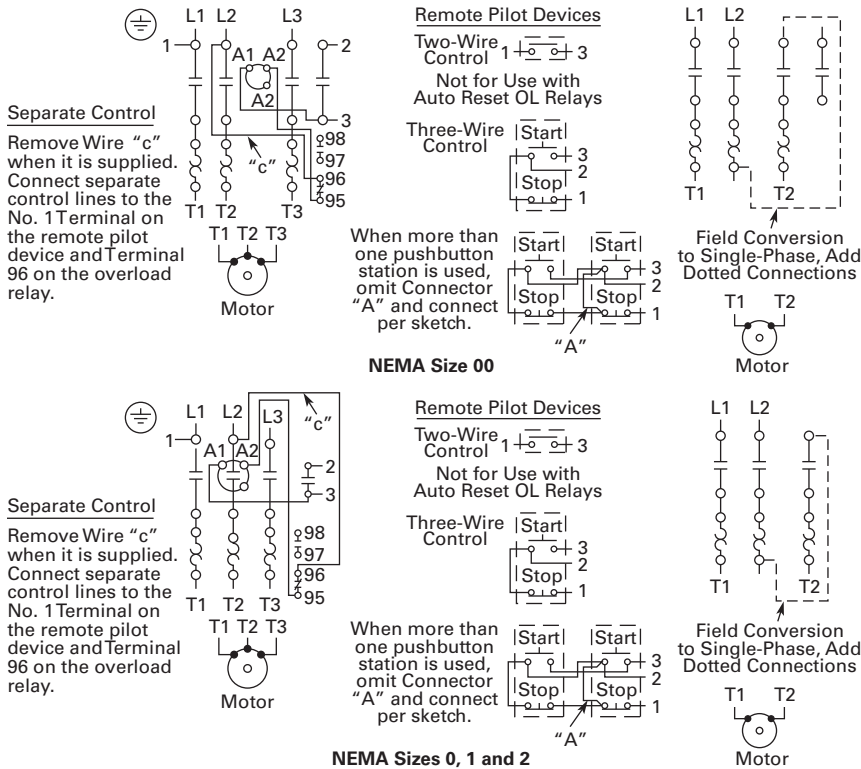

NEMA Size 1—BN15DN0AB



## Contents

<i><b>Description</b></i>	<i><b>Page</b></i>
Contactors—Non-Reversing and Reversing . . . . .	<b>V5-T2-4</b>
Starters—Three-Phase Non-Reversing and Reversing, Full Voltage . . . . .	<b>V5-T2-10</b>
Starters—Single-Phase Non-Reversing, Full Voltage, Bi-Metallic Overload	
Product Selection . . . . .	<b>V5-T2-16</b>
Wiring Diagrams . . . . .	<b>V5-T2-16</b>
Dimensions . . . . .	<b>V5-T2-17</b>
Accessories . . . . .	<b>V5-T2-21</b>
Renewal Parts . . . . .	<b>V5-T2-30</b>
Technical Data and Specifications . . . . .	<b>V5-T2-34</b>
Relays—Thermal Overload . . . . .	<b>V5-T2-38</b>
C440/ <i>XT</i> Electronic Overload Relay . . . . .	<b>V5-T2-48</b>

## Starters—Single-Phase Non-Reversing, Full Voltage, Bi-Metallic Overload

### Product Description

Single-phase, full voltage magnetic starters connect the motor directly across the line, allowing it to draw full inrush current during start-up. These starters are most commonly used for control of self-starting single-phase motors up to 15 hp at 230V. They consist of a two-pole electromagnetic contactor to make and break the motor power circuit and an overload relay to provide running overload protection. Starters listed in the table include:

- Two-pole Freedom Series contactor with long life twin break, silver cadmium oxide contacts. Generously sized for low resistance and cool operation. Designed to 3 million electrical operations at maximum hp and 30 million mechanical operations to Size 0, 10 million operations to Size 2 and 6 million operations to Size 3
- Three-pole Freedom Series overload with poles two and three wired in series for motor overload protection. This overload is ambient compensated, selectable manual or automatic reset, interchangeable Class 10 or 20 heater packs, 1.0 or 1.15 service factor selectability, overload trip indication and electrically isolated NO-NC contacts (pull RESET button to test)
- Holding circuit NO auxiliary contact supplied as standard. On Size 00, the contact occupies the 4th power pole position. Sizes 0–3 have the NO auxiliary mounted on the right side of the contactor
- Steel mounting plate as standard on all open type starters. Wired for separate or common control

# 2.1

## NEMA Contactors and Starters

### Freedom Series

#### Product Selection

2

#### When Ordering Specify

- Catalog number
- Heater pack number (see selection table, **Pages V5-T2-40 to V5-T2-42**) or full load current

#### BN16DM0AB



#### Type BN16 NEMA—Manual or Automatic Reset Overload Relay

NEMA Size	Maximum Horsepower Motor Voltage	Single-Phase		Magnet Coil Voltage (60 Hz)	Open Type Two-Pole Catalog Number
00	115	1/3		120 <sup>①</sup>	<b>BN16AN0AC</b>
	230	1		240	<b>BN16AN0BC</b>
0	115	1		120 <sup>①</sup>	<b>BN16BN0AC</b>
	230	2		240	<b>BN16BN0BC</b>
1	115	2		120 <sup>①</sup>	<b>BN16DN0AB</b>
	230	3		240	<b>BN16DN0BB</b>
1P	115	3		120 <sup>①</sup>	<b>BN16PN0AB</b>
	230	5		240	<b>BN16PN0BB</b>
2	115	3		120 <sup>①</sup>	<b>BN16GN0AB</b>
	230	7-1/2		240	<b>BN16GN0BB</b>
3	115	7-1/2		120 <sup>①</sup>	<b>BN16KN0A</b>
	230	15		240	<b>BN16KN0B</b>

Starter catalog numbers do not include heater packs. Select one carton of three heater packs. Heater pack selection, **Pages V5-T2-40 to V5-T2-42**.

#### Note

- ① For separate 120V control circuit. For maximum hp at listed motor voltages, use the rating of other starters of same size.

#### Wiring Diagrams

#### Single-Phase Applications (Factory Wired)

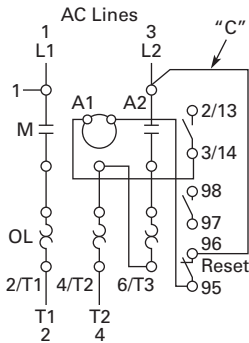

#### Separate Control

Remove Wire "C" if supplied and connect separate control lines to the Number 1 Terminal on the remote pilot device and to the Number 96 Terminal on the overload relay.

Front View of Panel



Single-Phase Motor

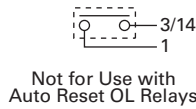

Two-Wire Control

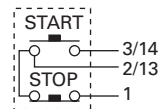

Three-Wire Control

When more than one pushbutton station is used, omit Connector "A" and connect per sketch at right.

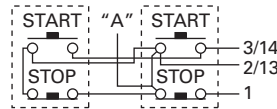

### Dimensions

Approximate Dimensions in Inches (mm)

#### Non-Reversing Starters, Bi-Metallic Overload—Open Type

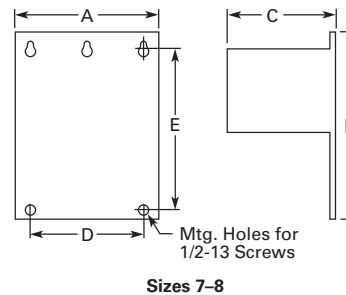
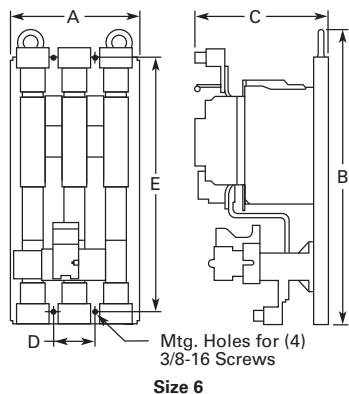
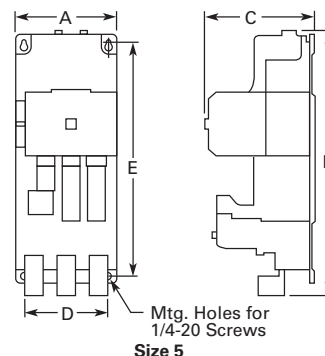
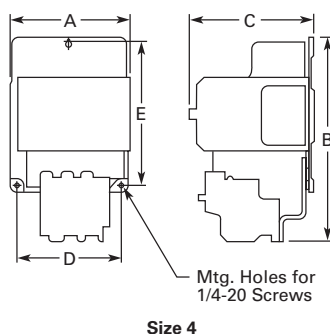
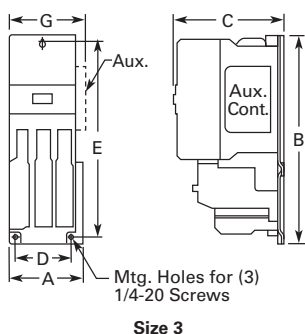
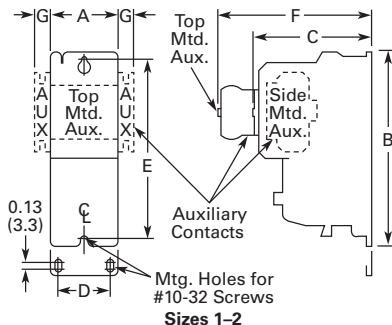
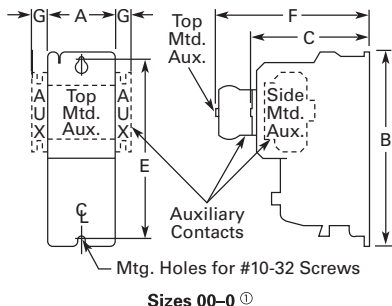

### Dimensions and Shipping Weights

NEMA Size	Wide A	High B	Deep C	Mounting D	Mounting E	F	G	Shipping Weight Lbs (kg)
00-0	1.80 (45.7)	6.60 (167.6)	3.52 (89.4)	—	6.07 (154.2)	4.90 (124.5)	0.54 (13.7)	2.2 (1.0)
1-1P	2.56 (65.0)	7.08 (179.8)	4.44 (112.8)	2.00 (50.8)	6.63 (168.4)	5.80 (147.3)	0.54 (13.7)	4.5 (2.0)
2	2.56 (65.0)	8.08 (205.2)	4.44 (112.8)	2.00 (50.8)	7.63 (193.8)	5.80 (147.3)	0.54 (13.7)	4.7 (2.1)
3	4.08 (103.6)	11.35 (288.3)	5.94 (150.9)	3.00 (76.2)	10.81 (274.6)	—	—	11.0 (5.0)
4	7.05 (179.1)	12.06 (306.3)	7.25 (184.2)	6.00 (152.4)	8.50 (215.9)	—	—	23.0 (10.4)
5	7.00 (177.8)	17.77 (451.4)	7.76 (197.1)	6.00 (152.4)	16.00 (406.4)	—	—	36.0 (16.3)
6	9.47 (240.5)	21.69 (550.9)	9.90 (251.5)	3.10 (78.7)	18.00 (457.2)	—	—	75.0 (34.1)
7	15.13 (384.3)	29.13 (739.9)	12.64 (321.1)	13.25 (336.6)	21.25 (539.8)	—	—	120.0 (54.5)
8	15.13 (384.3)	34.50 (876.3)	15.00 (381.0)	13.25 (336.6)	16.75 (425.5)	—	—	210.0 (95.3)

#### Note

Ⓞ Holding circuit contact for Size 00 occupies 4th power pole position—no increase in width.



# 2.1

## NEMA Contactors and Starters

### Freedom Series

Approximate Dimensions in Inches (mm)

#### 2 Reversing Starters, Bi-Metallic Overload—Open Type

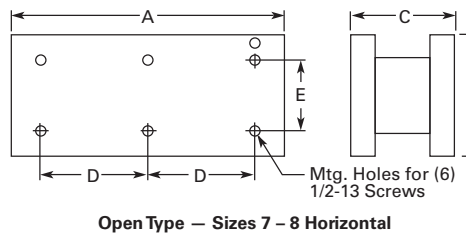
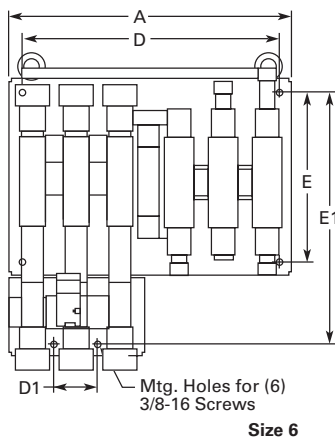
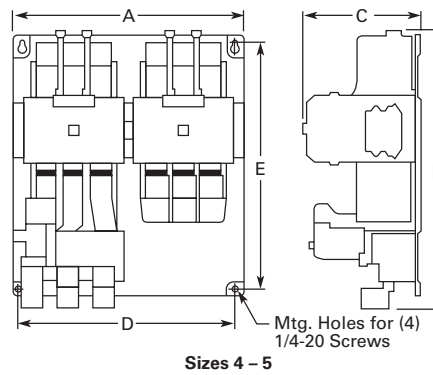
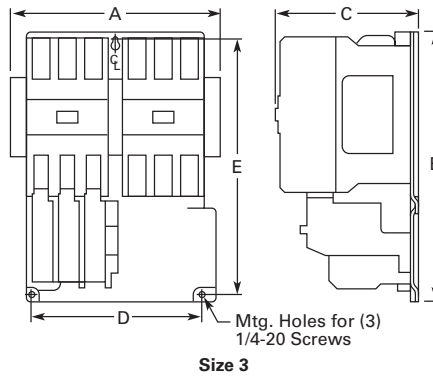
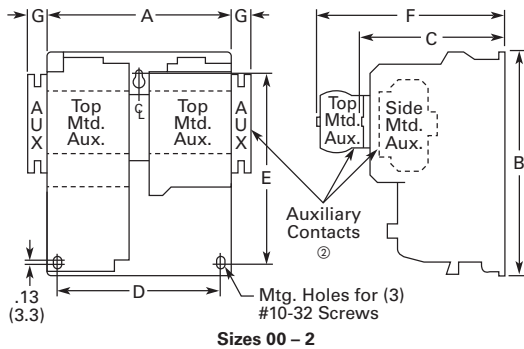

#### Dimensions and Shipping Weights

NEMA Size	Wide A	High B	Deep C	Mounting D	Mounting E	D1	E1	F	G	Shipping Weight Lbs (kg)
00-0	4.20 (106.7)	7.38 (187.5)	3.52 (89.4)	3.50 (88.9)	6.87 (174.5)	—	—	4.90 (124.5)	0.54 (13.7)	3.6 (1.6)
1	5.71 (145.0)	7.08 (179.8)	4.44 (112.8)	5.25 (133.4)	5.75 (146.1)	—	—	5.80 (147.3)	0.54 (13.7)	8.3 (3.8)
2	5.71 (145.0)	8.08 (205.2)	4.44 (112.8)	5.25 (133.4)	6.75 (171.5)	—	—	5.80 (147.3)	0.54 (13.7)	8.5 (3.9)
3	8.70 (221.0)	11.35 (288.3)	5.94 (150.9)	7.00 (177.8)	10.81 (274.6)	—	—	—	—	20.0 (9.1)
4	14.68 (372.9)	12.06 (306.3)	7.25 (184.2)	13.50 (342.9)	8.50 (215.9)	—	—	—	—	49.0 (22.2)
5	14.50 (368.3)	17.77 (451.4)	7.76 (197.1)	13.50 (342.9)	16.00 (406.4)	—	—	—	—	68.0 (30.9)
6	19.77 (502.2)	22.63 (574.8)	9.90 (251.5)	18.00 (457.2)	12.00 (304.8)	3.10 (78.7)	18.00 (457.2)	—	—	90.0 (40.9)
7	28.06 (712.7)	32.13 (816.1) ①	12.70 (322.6)	12.75 (323.9)	21.25 (539.8)	—	—	—	—	175.0 (79.5)
8	30.38 (771.7)	41.50 (1054.1) ①	14.70 (373.4)	14.13 (358.9)	16.75 (425.5)	—	—	—	—	430.0 (195.2)

#### Notes

- ① Includes cross wiring overhang.
- ② See catalog listings for type and location of auxiliary contacts supplied with a particular starter.

Approximate Dimensions in Inches (mm)

### Reversing Starters—Vertical Construction, Bi-Metallic Overload—AN56V Open Vertical Starter

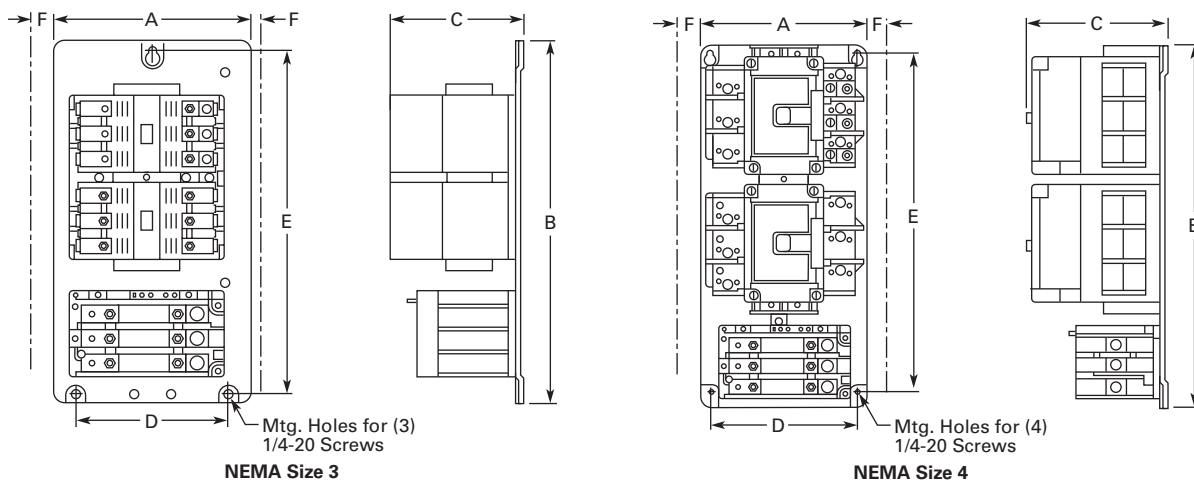
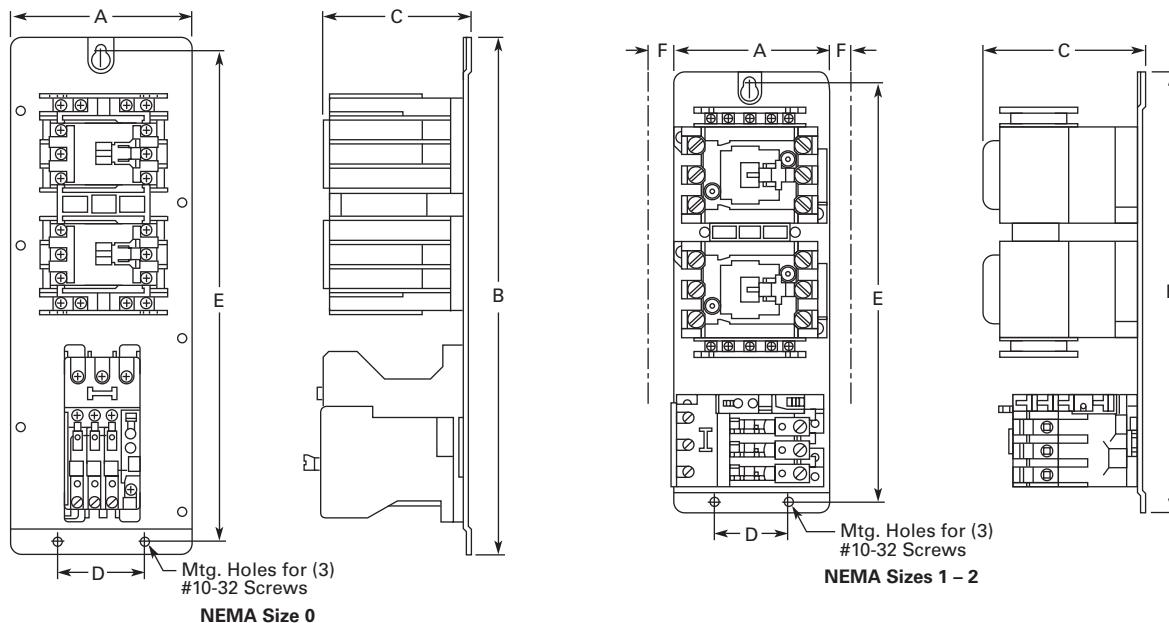

### Dimensions and Shipping Weights

NEMA Size	Wide A	High B	Deep C	Mounting Wide D	Mounting High E	Wire Zone	Shipping Weight Lbs (kg)
0	4.25 (108.0)	12.05 (306.1)	3.84 (97.5)	2.00 (50.8)	11.50 (292.1)	—	4.0 (1.8)
1	4.25 (108.0)	12.05 (306.1)	3.86 (98.0)	2.00 (50.8)	11.50 (292.1)	1.00 (25.4)	9.0 (4.1)
2	4.25 (108.0)	12.05 (306.1)	3.86 (98.0)	2.00 (50.8)	11.50 (292.1)	1.00 (25.4)	9.5 (4.3)
3	9.25 (235.0)	16.75 (425.5)	5.18 (131.6)	7.15 (181.6)	16.07 (408.2)	①	21.0 (9.5)
4	9.08 (230.6)	19.84 (503.9)	5.18 (131.6)	8.00 (203.2)	18.51 (470.2)	1.50 (38.1)	50.0 (22.7)

**Note**

① Wire overhang 1.00 mm left, 50 mm right.

# 2.1

## NEMA Contactors and Starters

### Freedom Series

Approximate Dimensions in Inches (mm)

2

#### Multispeed Starters, Bi-Metallic Overload—AN700 Open Vertical Starter

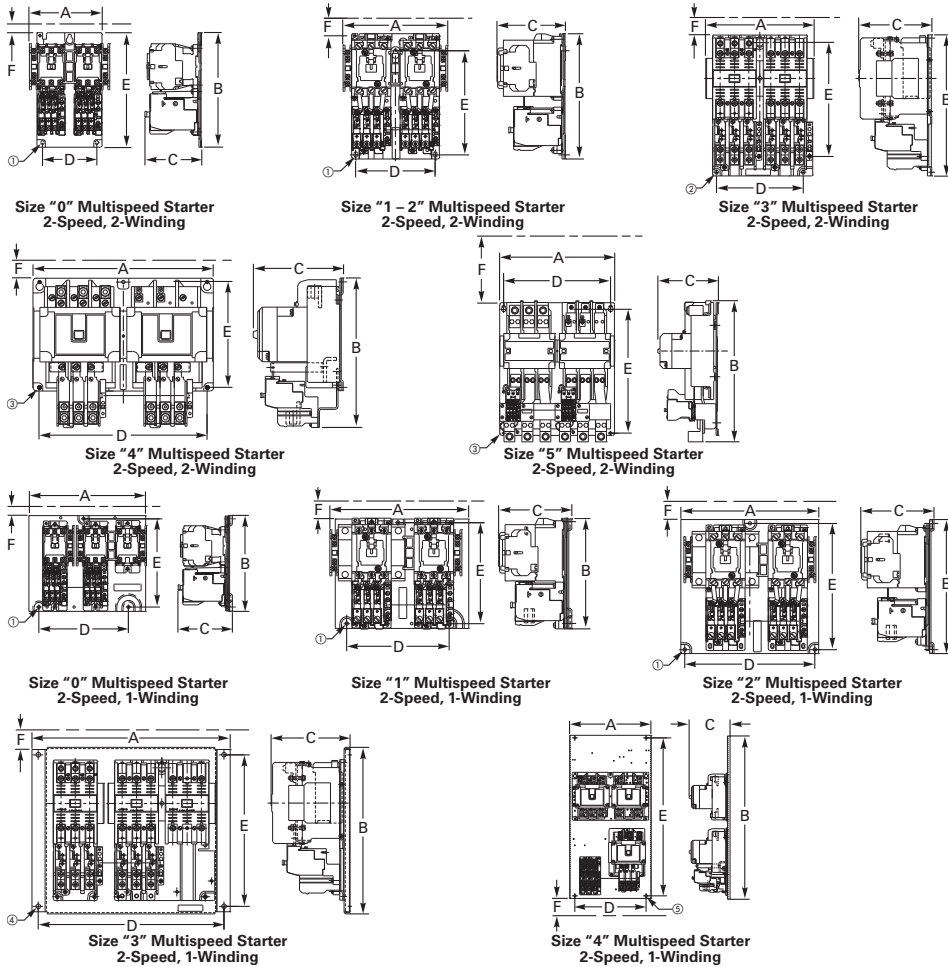

#### Dimensions and Shipping Weights

NEMA Size	Wide A	High B	Deep C	Mounting Wide D	Mounting High E	Wire Zone F	Shipping Weight Lbs (kg)
<b>Two-Speed—Selective Control—Separate Winding</b>							
0	5.19 (132)	7.38 (188)	3.52 (89)	3.50 (89)	6.87 (175)	0.89 (23)	4.5 (2.0)
1	5.66 (144)	7.08 (180)	4.42 (112)	5.25 (133)	5.75 (146)	1.23 (31)	9.0 (4.1)
2	5.66 (144)	8.08 (205)	4.42 (112)	5.25 (133)	6.75 (165)	1.63 (41)	10.0 (4.5)
3	8.72 (221)	11.35 (288)	5.89 (150)	7.00 (178)	10.81 (275)	1.77 (45)	24.0 (10.9)
4	14.68 (373)	12.06 (306)	7.25 (184)	13.50 (343)	8.50 (216)	1.95 (50)	53.0 (24.1)
5	14.50 (368)	17.82 (453)	7.76 (197)	13.50 (343)	16.00 (406)	4.56 (116)	73.0 (33.1)
<b>Two-Speed—Selective Control—Reconnectable Winding</b>							
0	8.62 (219)	7.06 (179)	3.82 (81)	6.62 (168)	6.50 (165)	0.50 (13)	6.0 (2.7)
1	8.97 (228)	7.12 (181)	4.72 (120)	6.62 (168)	6.50 (165)	1.04 (26)	10.0 (4.5)
2	8.90 (226)	8.62 (219)	4.75 (121)	8.40 (213)	8.12 (206)	1.03 (26)	11.0 (5.0)
3	16.00 (406)	13.46 (342)	6.38 (162)	15.00 (381)	12.25 (311)	1.24 (31)	31.0 (14.1)
4	15.46 (393)	31.00 (787)	7.74 (197)	13.50 (343)	30.00 (762)	1.84 (47)	72.0 (32.7)

#### Notes

- ① Mounting holes for (3) #10 screws.
- ② Mounting holes for (3) 1/4-20 screws.
- ③ Mounting holes for (4) 1/4-20 screws.
- ④ Mounting holes for (4) 5/16 screws.
- ⑤ Mounting holes for (4) 3/8 screws.

### Accessories

#### Three-Pole Top Mounted Fuse Block Kit

##### IEC Sizes A–K, NEMA Sizes 00–2

Field mount to Freedom Series starters and contactors. Designed to save space and

reduce installation costs. They provide short circuit protection for branch circuits.

##### Mounted Fuse Block Kit

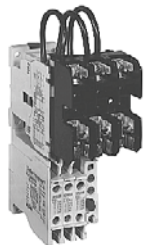

##### Fuse Block Kits

Fuse Type	Catalog Number
Class H—30A 250V	<b>C350KH21</b>
Class R—30A 250V	<b>C350KR21</b>
Class G—15A 300V	<b>C350KG37</b>
Class G—20A 300V	<b>C350KG38</b>
Class G—30A 300V	<b>C350KG31</b>
Class G—60A 300V	<b>C350KG32</b>
Class T—30A 300V	<b>C350KT31</b>
Class T—60A 300V	<b>C350KT32</b>
Class J—30A 600V	<b>C350KJ61</b>
Class J—60A 600V	<b>C350KJ62</b>
Type M—30A 600V ①	<b>C350KM61</b>
Class CC—30A 600V	<b>C350KC63</b>
Class T—30A 600V	<b>C350KT61</b>
Class T—60A 600V	<b>C350KT62</b>

#### Three-Pole Top Mounted Fuse Block Kit

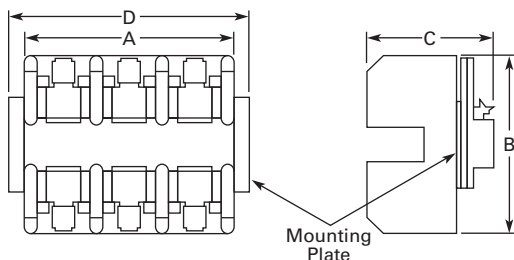

Fuse Block Class	Amperes	Volts	Approximate Dimensions in Inches (mm)			
			Wide A	High B	Deep C	D
G	15, 20, 30 60	300	2.40 (61.0)	3.00 (76.2)	2.04 (51.8)	—
		300	2.62 (66.5)	4.25 (108.0)	2.08 (52.8)	—
H	30	250	3.00 (76.2)	3.10 (78.7)	2.23 (56.6)	3.62 (91.9)
J	30, 60	600	4.81 (122.2)	4.12 (104.6)	2.82 (71.6)	—
M, CC	30	600	2.40 (61.0)	3.00 (76.2)	2.04 (51.8)	—
R	30	250	3.00 (76.2)	3.10 (78.7)	2.23 (56.6)	3.62 (91.9)
T	30, 60	300	3.44 (87.4)	3.00 (76.2)	2.33 (59.2)	—
		30	600	3.75 (95.3)	3.31 (84.1)	2.26 (57.4)
	60	600	4.87 (123.7)	3.00 (76.2)	2.58 (65.5)	—

#### Mechanical Interlock and Reversing Kits

Mechanical interlocks and reversing kits are designed for field assembly of reversing contactors or starters from Freedom Series components. The reversing kits include a mechanical

interlock, stabilizer bar and a pre-cut, trimmed and formed wire set. Auxiliary contacts, if required, must be ordered separately. See **Pages V5-T2-25 and V5-T2-26.**

##### C321KM60B



##### Part No. 23-7165



##### Wire Set



##### Mechanical Interlock Only ②③

Application			
NEMA Size	IEC Size	Contactors Mounting	Catalog Number
00–2	A–K	Horizontal	<b>C321KM60B</b>
3	L–N	Horizontal	<b>C321KM30</b>
3 to 4	N to P	Horizontal	<b>C321KM43</b>
4	P–S	Horizontal	<b>C321KM40</b>
4 to 5	—	Horizontal	<b>C321KM45</b>
4 to 6	S to T/U	Horizontal	<b>C321KM80</b>
5	—	Horizontal	<b>C321KM50</b>
5 to 6	—	Horizontal	<b>C321KM56</b>
6	T and U	Horizontal	<b>C321KM70</b>
6 to 7	T/U to V–X	Horizontal	<b>C321KM90</b>
7	V, W and X	Horizontal	<b>C321KM34</b>
4 or 5 to 5	P–S to 5	Vertical	<b>C321KM55</b>
5 to 6	—	Vertical	<b>C321KM65</b>
6	T and U	Vertical	<b>C321KM66</b>
6 to 7	T/U to V–X	Vertical	<b>C321KM67</b>

##### Reversing Kits (Horizontal Contactor Mounting Only)

Application		
NEMA Size	IEC Size	Catalog Number
00	A–C	<b>C321KM60K14B</b>
0	D–F	<b>C321KM60K13B</b>
1	—	<b>C321KM60K15B</b>
2	G–K	<b>C321KM60K16B</b>
3	—	<b>C321KM60K17</b> ④
—	L and M	<b>C321KM60K21</b> ④
—	N	<b>C321KM60K18</b> ④
4	—	<b>C321KM60K19</b> ④
5	—	<b>C321KM60K20</b> ④
—	P–S	<b>C321KM60K44</b> ④

##### Notes

- ① Type M fuse block not approved for branch circuit protection.
- ② Without cross-wiring.
- ③ For use with latest series product.
- ④ Kit includes (2) NC auxiliary contacts.

# 2.1

## NEMA Contactors and Starters

### Freedom Series

2

#### Solid-State Timers

##### **Solid-State ON DELAY Timer—Side Mounted on Freedom Series NEMA 00–2, IEC A–K and C25D, C25E and C25F Frame**

This timer is designed to be **wired in series with the load** (typically a coil). When the START button is pushed (power applied to timer), the

ON DELAY timing function starts. At the completion of the set timing period, timer and series wired load will both be energized.

#### Solid-State Timer



#### Mounted Timer Product Selection

Timing Range	Catalog Number <sup>①②③</sup>
0.1–1.0 seconds	<b>C320TDN1_</b>
1–30 seconds	<b>C320TDN30_</b>
30–300 seconds	<b>C320TDN300_</b>
5–30 minutes	<b>C320TDN3000_ <sup>④</sup></b>

#### Shorting Bar Kits

These kits provide phase-to-phase power connections of contactors for field assembly. The kits include bus

connections and mounting hardware. The shorting bars connect all three phases of a single contactor.

#### Shorting Bar Kits

Description	Catalog Number
NEMA Size 3, IEC Sizes L–N	<b>C321SB18</b>
NEMA Size 4, IEC Sizes A–S	<b>C321SB19</b>
NEMA Size 6, IEC Sizes T and U	<b>C321SB22</b>

#### Pneumatic Timers—Top Mounted

Attachment mounts on top of any NEMA Size 00–2 or IEC Size A–K Freedom Series starter or contactor (top mounted auxiliary contacts cannot be installed on device when timer is used). Timer

unit has 1NO-1NC isolated timed contacts—circuits in each pole must be the same polarity. Units are convertible from OFF to ON DELAY or vice-versa.

#### Pneumatic Timers



#### Pneumatic Timers

Timing Range	Catalog Number
0.1 to 30 seconds	<b>C320TP1</b>
10 to 180 seconds	<b>C320TP2</b>

#### Maximum Ampere Ratings

Description	Vac			
	120	240	480	600
Make	30	15	7.5	6
Break	3	1.5	0.75	0.6

#### Locking Cover for Overload Relay—C306 Only

Snap-on transparent or opaque plastic panel for covering access port to the overload relay trip setting

dial—helps prevent accidental or unauthorized changes to trip and reset setting.

#### Locking Cover for Overlay Relay



#### Locking Cover for Overlay Relay

Description	Min. Ordering Quantity (Std. Pkg.)	Catalog Number
Clear cover, no accessibility	50	<b>C320PC3</b>
Gray cover, no accessibility, with Auto only nib	50	<b>C320PC4</b>
Gray cover, no accessibility, with Manual only nib	50	<b>C320PC5</b>
Gray cover with FLA dial accessibility, A, B, C, D positions and Auto only nib	50	<b>C320PC6</b>
Gray cover with FLA dial accessibility, A, B, C, D positions and Manual only nib	50	<b>C320PC7</b>

#### Notes

- ① Add operating voltage suffix to catalog number.  
**A** = 120V, **B** = 240V, **E** = 208V
- ② Rated 0.5 ampere pilot duty—not to be used on larger contactors.
- ③ Terminal connections are quick connects only. Two per side.
- ④ 240V operating voltage not available for C320TDN3000\_.

## Identification Markers

### IEC Sizes A–K, NEMA Sizes 00–2

Designed to snap on the face of individual devices. Includes holder and labels. personalized identification of

### Identification Markers

Description	Catalog Number
Identification marker	C320DL2

## Control Circuit Fuse Block

These panel mounted fuse holders, designed for control circuit protection or other similar low current requirements, have extractor type fuse caps. The Class CC rejection type fuses (KTK-R) used in these holders are intended for use with equipment designated as being suitable for use on systems having high available fault currents. If branch circuit protective device is 45A or greater, C320FBR fuse kit may be required for control circuit protection per NEC 430-72.

### Control Circuit Fuse Block



### Control Circuit Fuse Block

Type	Max. Amperes	Catalog Number
Fuse holder only	15	C320FB ①
	30	C320FBR ②

## Dimensions

Approximate Dimensions in Inches (mm)

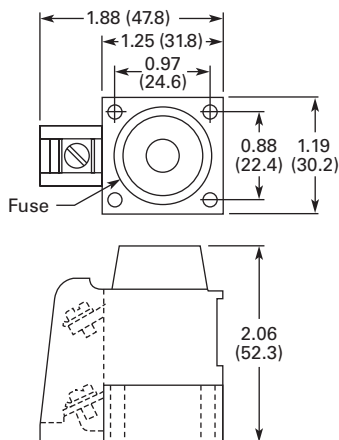

## DIN Rail Mounting Channel—35 mm

Designed for DIN rail mounting of IEC style contactors and starters.

### DIN Rail



### DIN Rail

Description	Catalog Number
1 meter length	MC382MA1

## Finger Protection Shields

Snap-on shields for both contactors and starters provide IEC Type IP20 finger protection. Prevents accidental contact with line/load terminals.

### Finger Protection Shields

Application	Catalog Number
NEMA Size 00, IEC Sizes A–C	C320LS1
NEMA Size 0, IEC Sizes D–F	C320LS2
<b>NEMA Sizes 1–2, IEC Sizes G–K</b>	
Contactors	C320LS3
Reversing contactors	C320LS4
<b>NEMA Size 1</b>	
Starters	C320LS5
Reversing starters	C320LS6
<b>NEMA Size 2, IEC Sizes G–K</b>	
Starters	C320LS7
Reversing starters	C320LS8

## Adapter to DIN Rail Mount

### NEMA 1–2 and IEC G–K Contactors

Designed to allow DIN rail mounting of NEMA 1–2 and IEC G–K contactors. Includes all hardware required to convert contactors from panel mounting to 35 mm DIN rail mounting.

### Adapter to DIN Rail Mount

Catalog Number
C320DN65

### Notes

- ① A fuse is not supplied, but holder will accept a Bussman Type KTK or KTK-R (13/32 in x 1-1/2 in) fuse, 600V maximum.
- ② Includes a 5A, 600V KTK-R fuse.

# 2.1

## NEMA Contactors and Starters

### Freedom Series

2

#### Transient Suppressor Kits

##### NEMA Sizes 00–2, IEC Sizes A–K

These kits limit high voltage transients produced in the control circuit when power is removed from the contactor or starter coil. There are three separate suppressors for use on 24–120V, 208–240V or 277–480V coils respectively.

These devices mount directly to the coil terminals of Freedom Series contactors or starters NEMA Sizes 00–2, IEC Sizes A–K and lighting contactors 10–60A. Reversing devices will require two.

##### C320TS2



##### NEMA Sizes 00–2, IEC Sizes A–K

Description	Coil Voltage ①	Catalog Number
Transient suppressor	24/120V	<b>C320TS1</b>
	208/240V	<b>C320TS2</b>
	277/480V	<b>C320TS3</b>

##### NEMA Sizes 3–5, IEC Sizes L–S

This device mounts on top of any side mounted auxiliary contact on Freedom Series NEMA Sizes 3–5, IEC Sizes L–S and lighting contactors 100–300A. It connects across coil terminals on any 120V contactor or starter magnet

coil (reversing starters or contactors require 2).

Limits high voltage transients produced in the circuit when power is removed from the coil.

##### C320AS1



##### NEMA Sizes 3–5, IEC Sizes L–S

Description	Coil Voltage	Catalog Number
Transient suppressor	120V	<b>C320AS1</b>

#### Add-On Power Pole Kit ②

##### NEMA Sizes 00–0, IEC Sizes A–F

This device mounts on the side of Freedom NEMA Size 00–0 and IEC Sizes A–F contactors. One unit can be mounted on each side and

carries UL, cUL and IEC ratings. The device is rated for resistive, inductive and lighting applications.

##### NEMA Sizes 00–0, IEC Sizes A–F

UL Ampere Rating				IEC 947 Ampere Rating					
Inductive 600V	Resistive 600V	Horsepower Single-Phase		Locked Rotor 240V	Lighting Ballast Tungsten 480V	AC-1 600V	AC-3 600V	AC-5a AC-5b 480V	1NO Power Pole Catalog Number
		115V	230V						
15	20	1/2	2	96	20	20	12	18	<b>C320PPD10</b>

#### Notes

- ① Suppressor is compatible with coil voltages/ranges as shown, both 50 and 60 Hz.
- ② Power pole kits sold for replacement purposes only. For new applications, order the correct four-pole and five-pole contactor catalog numbers.

#### Adhesive Dust Cover

##### NEMA Sizes 00–2, IEC Sizes A–K

These adhesive stickers come 25 to a package and provide extra protection from contaminants when applied to the sides of Freedom NEMA Sizes 00–2 and IEC

Sizes A–K. Adhesive covers are easily applied to side opening where auxiliaries are not installed and provide extra protection from metal filings and other debris.

##### NEMA Sizes 00–2, IEC Sizes A–K

Description	Catalog Number
25 to a package	<b>C320DSTCVR</b>

## Auxiliary Contacts

### Contact Configuration Code



This two-digit code is found on the auxiliary contact to assist in identifying the specific contact configuration. The first digit indicates the quantity of NO contacts and the second indicates the quantity of NC contacts.

### NEMA Sizes 00–2—IEC Sizes A–K

The auxiliary contacts listed on this page are designed for installation on Freedom Series starters and contactors. Snap-on design facilitates quick, easy installation.

These bifurcated design contact blocks, featuring silver cadmium alloy contacts, are well suited for use in very low energy (logic level) circuits.

### NEMA Sizes 00–2—IEC Sizes A–K <sup>①</sup>

	Description	Contact Configuration Code <sup>②</sup>	Catalog Number
<b>Side Mounted</b> 	<b>Side Mounted</b>		
	1NO	10	C320KGS1
	1NC	01	C320KGS2
	1NO-1NC	11	C320KGS3
	2NO	20	C320KGS4
	2NC	02	C320KGS5
	1NO-1NCI	N/A	C320KGS6
	1NO (EC)-1NC (LO)	N/A	C320KGS7
1NCI	N/A	C320KGS8	
<b>Top Mounted</b> 	<b>Top Mounted</b>		
	1NO	10	C320KGT1
	1NC	01	C320KGT2
	1NO-1NC	11	C320KGT3
	2NO	20	C320KGT4
	2NC	02	C320KGT5
	1NO-1NCI	N/A	C320KGT6
	1NO (EC)-1NC (LO)	N/A	C320KGT7
	1NCI	N/A	C320KGT8
	3NO	30	C320KGT9
	2NO-1NC	21	C320KGT10
	1NO-2NC	12	C320KGT11
	3NC	03	C320KGT12
	4NO	40	C320KGT13
	3NO-1NC	31	C320KGT14
	2NO-2NC	22	C320KGT15
	1NO-3NC	13	C320KGT16
	4NC	04	C320KGT17
	3NO-1NCI	N/A	C320KGT18
	2NO-1NCI-1NC	N/A	C320KGT19
	2NO-1NO (EC)-1NC (LO)	N/A	C320KGT20
1NO-1NC-1NO (EC)-1NC (LO)	N/A	C320KGT21	

#### Notes

- ① NCI = Normally Closed early opening designed for use in reversing applications. EC = Early Closing. LO = Late Opening.
- ② For reference only—not part of catalog number.



# 2.1

## NEMA Contactors and Starters

Freedom Series

### NEMA Sizes 3–8—IEC Sizes L–Z

2

C320KGS42



#### Base Auxiliary Contacts— NEMA Sizes 3–5, IEC Sizes L–S

Circuit	Contact Configuration Code <sup>①</sup>	NEMA Size 3 IEC Sizes L–N Catalog Number	NEMA Sizes 4–5 IEC Sizes P–S Catalog Number
NO	10	C320KGS31	C320KGS41
NO-NC	11	C320KGS32	C320KGS42

C320KGS22



#### Auxiliary Contacts—NEMA Sizes 3–5, IEC Sizes L–S

Circuit	Contact Configuration Code <sup>①</sup>	Catalog Number
NO	10	C320KGS20
NC	01	C320KGS21
NO-NC <sup>②</sup>	11	C320KGS22

#### Sealed Logic Level

Circuit	Contact Configuration Code <sup>①</sup>	Catalog Number
NO	10	C320KGS20L
NC	01	C320KGS21L
NO-NC <sup>③</sup>	11	C320KGS22L

#### Auxiliary Contacts—NEMA Sizes 6–8, IEC Sizes T–Z

Circuit	Contact Configuration Code <sup>①</sup>	Size	Catalog Number
NO-NC	11	NEMA 8, IEC Z	C320KA5
2NO-2NC	22	NEMA 6–7	C320KA6
2NO-2NC	22	IEC T–X	C320KA8

### Auxiliary Contact Ratings (Amperes)

#### Ratings—NEMA A600

Current	AC Volts			
	120V	240V	480V	600V
Make	60	30	15	12
Break	6	3	1.5	1
Continuous	10	10	10	10

#### Ratings—NEMA P300

Continuous Thermal Rating: 5A

DC Volts	Make/Break Amperes
125	1.10
250	0.55

#### Ratings—Logic Level

##### Minimum Ratings for Logic Level and Hostile Atmosphere Application

Minimum Amperes	20 mA
Minimum Volts	24 Vac/Vdc

#### Ratings C320KGS20L, C320KGS21L, C320KGS22L

DC-12		AC-12	
$U_e$	$I_e$	$U_e$	$I_e$
80	0.1	250	0.1

#### Notes

<sup>①</sup> For reference only—not part of catalog number.

<sup>②</sup> NO-NC occupies two position—L2 and L3, or R2 and R3. See figure on **Page V5-T2-27**.

<sup>③</sup> Form C contacts.

## Auxiliary Contact Location

### NEMA Sizes 00–2, IEC Sizes A–K

The sketches below illustrate the maximum number of auxiliary contacts that can be assembled to a contactor or starter and their locations.

assembled to a contactor or starter and their locations.

### Auxiliary Contacts

Size	Poles	Available Mounting Positions ①②		Catalog Number
		Open Type	Enclosed	
A–K	3	T1, L1	L1	<b>AE16</b>
00	3	T1, L1, R1	L1	<b>AN16</b>
0–2	3	T1, L1	L1	
A–K	3	L1, R1	L1, R1	<b>AE56</b>
00–2	3	T1, T2	—	<b>AN56</b>
A–C	2–4	T1, L1, R1	L1, R1	<b>CE15</b>
D–K	3	T1, L1	L1	
G–J	4	T1, R1	—	
G–J	5	T1	—	
00	2–4	T1, L1, R1	L1	<b>CN15</b>
0–2	2–3	T1, L1	L1	
1, 2	4	T1, L1	—	
1, 2	5	T1, L1	—	
10A	2–4	T1, L1, R1	L1	<b>CN35</b>
20–60A	2–3	T1, L1	L1	
60A	4	T1, L1	—	
60A	5	T1, L1	—	
A–K	3	L1, R1	L1, R1	<b>CE55</b>
00–2	3	T1, T2	—	<b>CN55</b>

### Auxiliary Contact Location

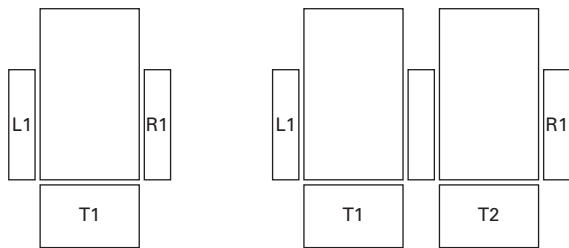

Top View

Top View

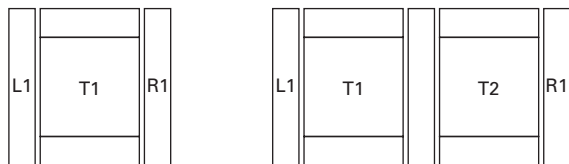

Front View

Front View

**Non-Reversing Contactors and Starters**

**Reversing Contactors and Starters**

### NEMA Sizes 3–8, IEC Sizes L–Z

The sketches below illustrate the maximum number of auxiliary contacts that can be assembled to a contactor and their locations.

**Note:** A base auxiliary contact must be added in position R1 before additional auxiliary contacts can be mounted on NEMA Size 3 and IEC Sizes L–N, or in L1 on NEMA Sizes 4–5 and IEC Sizes P–S.

### Mounting Positions

Size	Available Mounting Positions ①
NEMA Size 3, IEC Sizes L–N	R2, R3, L1, L2, L3
NEMA Sizes 4–5, IEC Sizes P–S	L2, L3, R1, R2, R3
NEMA Sizes 6–7, IEC Sizes T–X	R1
NEMA Size 8, IEC Size Z	L2, R2

### Auxiliary Contact Location

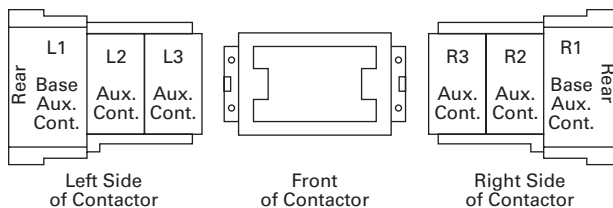

**NEMA Sizes 3–5  
IEC Sizes L–S**

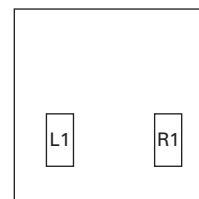

**NEMA Sizes 6–7  
IEC Sizes T, U, V, W and X**

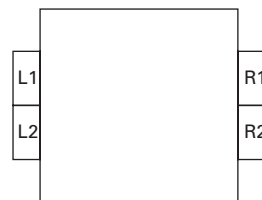

**NEMA Size 8  
IEC Size Z**

### Notes

- ① Available positions on contactors or starters other than what is factory installed.
- ② When a pneumatic timer is mounted on contactor, only side mounted auxiliary contact positions are available. The solid-state timer, when added, takes up side mounted auxiliary contact position.

#### DC Magnet Coils

##### When Ordering Specify

##### Conversion Kit for Field Assembly

- Catalog number

##### Factory Installed DC Coil

- For factory installed DC magnet coil on AC contactors or non-combination starters (open type only), substitute the code suffix from the table on this page for the magnet coil identifier in the device catalog number. EXAMPLE: For Size 0 AC contactor with a 24 Vdc coil, change AN16BN0AC to AN16BN0T1C

##### Application

- Connect for separate control
- Not for use with cover control switch operators
- Use twin break, heavy-duty pilot devices
- Designed for +10%, -20% rated voltage, continuous duty operation

##### Non-Reversing Kit Consists of:

- One encapsulated DC magnet coil
- One NCI or NO/NCI side mounted auxiliary contact

**Note:** These kits are supplied with a NO/NCI side mounted auxiliary contact in place of the NCI contact.

- Two blue colored connection wires
- One instruction publication

##### Operation

See next page for operation details.

#### DC Magnet Coils

Contactor or Starter Size	IEC	Volts	Conversion Data			NCI Interlock	Complete Conversion Kit		Factory Installed Code Suffix
			Magnet Coil	Amps P.U./Seal	Watts P.U./Seal		Catalog Number	Ship Wt. Lbs (kg)	
NEMA			Coil Number						
<b>Non-Reversing—Kit Includes NCI Side Mounted Auxiliary Contact</b>									
00 and 0 CN35–A, B, D D15 Relays	A–F	12	<b>9-2988-11</b>	6.4/0.28	76.8/3.36	<b>C320KGD1</b>	<b>C335KD3R1</b>	1.0 (0.5)	<b>R1</b>
		24	<b>9-2988-12</b>	3.2/0.14	76.8/3.36	<b>C320KGD1</b>	<b>C335KD3T1</b>		<b>T1</b>
		48	<b>9-2988-13</b>	1.6/0.07	76.8/3.36	<b>C320KGD1</b>	<b>C335KD3W1</b>		<b>W1</b>
		120	<b>9-2988-14</b>	0.64/0.028	76.8/3.36	<b>C320KGD1</b>	<b>C335KD3A1</b>		<b>A1</b>
① 00 and 0 CN35–A, B, D D15 Relays	A–F	12	<b>9-2988-11</b>	6.4/0.28	76.8/3.36	<b>C320KGD2</b> ①	<b>C335KD3R4</b>	1.0 (0.5)	<b>R4</b>
		24	<b>9-2988-12</b>	3.2/0.14	76.8/3.36	<b>C320KGD2</b> ①	<b>C335KD3T4</b>		<b>T4</b>
		48	<b>9-2988-13</b>	1.6/0.07	76.8/3.36	<b>C320KGD2</b> ①	<b>C335KD3W4</b>		<b>W4</b>
		120	<b>9-2988-14</b>	0.64/0.028	76.8/3.36	<b>C320KGD2</b> ①	<b>C335KD3A4</b>		<b>A4</b>
1 and 2 CN35–G	G–K	12	<b>9-2990-1</b>	15.4/0.42	185/4.98	<b>C320KGD5</b>	<b>C335KD4R4</b>	1.0 (0.5)	<b>R4</b>
		24	<b>9-2990-2</b>	7.7/0.21	185/4.96	<b>C320KGD5</b>	<b>C335KD4T4</b>		<b>T4</b>
		48	<b>9-2990-3</b>	3.9/0.11	185/5.04	<b>C320KGD5</b>	<b>C335KD4W4</b>		<b>W4</b>
		120	<b>9-2990-4</b>	1.5/0.041	185/4.87	<b>C320KGD5</b>	<b>C335KD4A4</b>		<b>A4</b>
3 CN35–K	L–N	12	<b>9-3002-1</b>	24/0.40	293/4.84	<b>C320KGD3</b>	<b>C335KD5R1</b>	2.0 (0.9)	<b>R1</b>
		24	<b>9-3002-2</b>	12/0.20	288/4.75	<b>C320KGD3</b>	<b>C335KD5T1</b>		<b>T1</b>
		48	<b>9-3002-3</b>	6.1/0.097	295/4.67	<b>C320KGD3</b>	<b>C335KD5W1</b>		<b>W1</b>
		120	<b>9-3002-4</b>	2.5/0.038	298/4.57	<b>C320KGD3</b>	<b>C335KD5A1</b>		<b>A1</b>
4 and 5 CN35–N, S	P–S	24	<b>9-2026-4</b>	18/0.22	400/5.3	<b>C320KGD3</b>	<b>C335KA3T1</b>	2.5 (1.1)	<b>T1B</b>
		48	<b>9-2026-3</b>	9/0.11	400/5.2	<b>C320KGD3</b>	<b>C335KA3W1</b>		<b>W1B</b>
		120	<b>9-2026-2</b>	3.3/0.05	450/5.4	<b>C320KGD3</b>	<b>C335KA3A1</b>		<b>A1B</b>
		240	<b>9-2026-1</b>	1.7/0.02	440/4.9	<b>C320KGD3</b>	<b>C335KA3B1</b>		<b>B1B</b>
<b>Reversing</b>									
00 and 0 CN35–A, B, D D15 relays	A–F	12	<b>(2) 9-2988-1</b>	6.4/0.28	76.8/3.36	<b>(2) C320KGD1</b>	<b>C335RD3R1</b> ②	1.0 (0.5)	<b>R1</b> ③
		24	<b>(2) 9-2988-2</b>	3.2/0.14	76.8/3.36	<b>(2) C320KGD1</b>	<b>C335RD3T1</b> ②		<b>T1</b> ③
		48	<b>(2) 9-2988-3</b>	1.6/0.07	76.8/3.36	<b>(2) C320KGD1</b>	<b>C335RD3W1</b> ②		<b>W1</b> ③
		120	<b>(2) 9-2988-4</b>	0.64/0.028	76.8/3.36	<b>(2) C320KGD1</b>	<b>C335RD3A1</b> ②		<b>A1</b> ③
1 and 2 CN35–G	G–K	12	<b>(2) 9-2990-1</b>	15.4/0.42	185/4.98	<b>(2) C320KGD3</b>	④	—	<b>R1</b> ③
		24	<b>(2) 9-2990-2</b>	7.7/0.21	185/4.96	<b>(2) C320KGD3</b>	④		<b>T1</b> ③
		48	<b>(2) 9-2990-3</b>	3.9/0.11	185/5.04	<b>(2) C320KGD3</b>	④		<b>W1</b> ③
		120	<b>(2) 9-2990-4</b>	1.5/0.041	185/4.87	<b>(2) C320KGD3</b>	④		<b>A1</b> ③

##### Notes

- ① These kits are supplied with a NO/NCI side mounted auxiliary contact in place of the NCI contact.
- ② Kit does not include mechanical interlock or crossover wiring. Two NO/NCI top mounted auxiliary contacts are supplied for electrical interlocking.
- ③ Factory installed DC coils on NEMA contactors and starters include a NO/NC top mounted auxiliary contact on each contactor for electrical interlocking. On IEC contactors and starters, a NC top mounted auxiliary contact is supplied on each contactor for electrical interlocking.
- ④ Available factory assembled only.

### Operation

These DC coil kits have separate pick-up and seal windings. A **special** (side mounted) early-break NCI auxiliary contact is used to either disconnect the pick-up winding or insert the seal winding in series with the pick-up winding, depending on the frame size of the contactor. DC coil kits come in two styles, a suffix **1** and a suffix **4**. Suffix 1 contains only the **special** (side mounted) early break NCI auxiliary contact. Suffix 4 contains a NO contact in the same package as the **special** (side mounted) early-break NCI auxiliary contact.

**Note:** For NEMA Sizes 00 and 0 and IEC Sizes A–F, contactors

may utilize either suffix 1 or 4 DC coil kits; starters may utilize suffix 4 DC coil kits only. For NEMA Sizes 1 and 2 and IEC Sizes G–K, both contactors and starters may utilize a suffix 4 DC coil kit only.

On the above sizes only, when the **special** auxiliary package is mounted on the side of a contactor or starter, **no** standard auxiliary contact may be mounted on the same side.

**Note:** For NEMA Sizes 3–5 and IEC Sizes L–S, special coil NCI clearing contact is an add-on auxiliary (**must** mount on a base mount auxiliary contact; normally a 1NO). This arrangement will normally account for two of the three contact positions on the side of each contactor or starter.

### Competitive Mounting Plates

The C321 adapter plates permit direct replacement of competitive starters with Freedom Series starters without drilling and tapping new mounting holes. Allen-Bradley 509, Eaton's A10

(adapter plate not required for replacing A10 Starter Sizes 1, 4 and 5), Furnas 14, ESP100, General Electric CR206, CR306, Siemens SXL, Square D 8536, Westinghouse A200, B200.

#### C321CMP1



#### Competitive Mounting Plates

Freedom NEMA Size	Index Number <sup>②</sup> Catalog Number
00, 0	C321CMP0
1	C321CMP1
2	C321CMP2
3	C321CMP3
4	C321CMP4
5	C321CMP5

#### Note

- ① 1NO available in Suffix 4 kits only.
- ② Handling number only—does not appear on product. The handling number is stamped on the carton label only.

### Elementary Diagrams

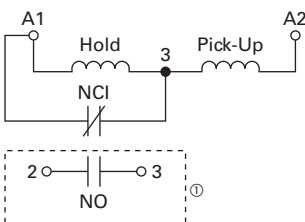

**DC Coil Elementary Diagram for NEMA Sizes 1–3 and IEC Sizes G–N Contactors and Starters**

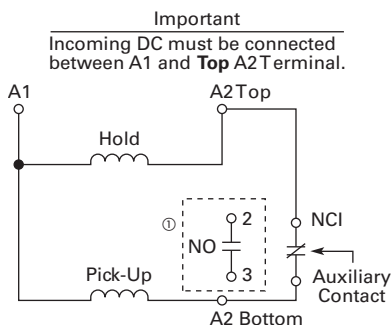

**DC Coil Elementary Diagram for NEMA Sizes 00, 0, 4 and 5 and IEC Sizes A–F and P–S Contactors and Starters**

### Special Modifications

For Catalog Numbers AN16, AN56, CE15, CN15, CN35, CN55

Addition or Special Feature	Starter Size —NEMA									
	00	0	1/—	2	3	4	5	6	7	8
<b>Control Circuit</b>										
Extra auxiliary circuit, factory installed NO or NC—each contact <sup>①</sup>	Consult sales office for pricing adders.									
Transient suppressor <sup>①</sup>	Consult sales office for pricing adders.									
<b>Power Circuit</b>										
Contactor/starter for ring lug capability—add Mod Code <b>T16</b> to catalog number <sup>②</sup> (Power terminals only, control terminals as standard) Standalone overload relays can not accept ring lugs on line side	Consult sales office for pricing adders.									
<b>Factory Installed Dust Covers</b>										
Factory installed C320DSTCVR—add Mod Code <b>-53</b> to catalog number <sup>①</sup>						NA	NA	NA	NA	NA

### Renewal Parts

For a complete listing of parts, refer to the Renewal Parts Publication Number referenced below.

For Catalog Numbers AN16, AN30, AN40, AN56, AN70, AN80, AN800, CN15, CN35 <sup>③</sup> and CN55 Contactors and Starters (Size 00, 0)

Description	NEMA Size 00		NEMA Size 0	
	Series B1 Part No.	Series C1 Part No.	Series B1 Part No.	Series C1 Part No.
<b>Renewal Parts Publication Number</b>	<b>22177</b>	<b>22177</b>	<b>22177</b>	<b>22177</b>
<b>Contact Kits</b>				
Two-pole	④	④	④	④
Three-pole	④	④	④	④
Four-pole	④	④	④	④
Five-pole	④	④	④	④
<b>Magnet Coils</b>				
	<b>Coil Suffix</b>			
120V 60 Hz or 110V 50 Hz	<b>A</b>	<b>9-2875-1</b>	<b>9-2875-1</b>	<b>9-2876-1</b>
240V 60 Hz or 220V 50 Hz	<b>B</b>	<b>9-2875-2</b>	<b>9-2875-2</b>	<b>9-2876-2</b>
480V 60 Hz or 440V 50 Hz	<b>C</b>	<b>9-2875-3</b>	<b>9-2875-3</b>	<b>9-2876-3</b>
600V 60 Hz or 550V 50 Hz	<b>D</b>	<b>9-2875-4</b>	<b>9-2875-4</b>	<b>9-2876-4</b>
208V 60 Hz	<b>E</b>	<b>9-2875-5</b>	<b>9-2875-5</b>	<b>9-2876-5</b>
277V 60 Hz	<b>H</b>	<b>9-2875-12</b>	<b>9-2875-12</b>	<b>9-2876-12</b>
208/240V 60 Hz	<b>J</b>	<b>9-2875-37</b>	<b>9-2875-37</b>	<b>9-2876-37</b>
240V 50 Hz	<b>K</b>	<b>9-2875-11</b>	<b>9-2875-11</b>	<b>9-2876-11</b>
380–415V 50 Hz	<b>L</b>	<b>9-2875-6</b>	<b>9-2875-6</b>	<b>9-2876-6</b>
380V 50 Hz	<b>L</b>	—	—	—
415V 50 Hz	<b>M</b>	—	—	—
550V 50 Hz	<b>N</b>	—	—	—
24V 60 Hz–24V 50 Hz	<b>T</b>	<b>9-2875-36</b>	<b>9-2875-36</b>	<b>9-2876-36</b>
24V 60 Hz	<b>T</b>	—	—	—
24V 50 Hz	<b>U</b>	<b>9-2875-36</b>	<b>9-2875-36</b>	<b>9-2876-36</b>
32V 50 Hz	<b>V</b>	<b>9-2875-16</b>	<b>9-2875-16</b>	<b>9-2876-16</b>
48V 60 Hz	<b>W</b>	<b>9-2875-8</b>	<b>9-2875-8</b>	<b>9-2876-8</b>
48V 50 Hz	<b>Y</b>	<b>9-2875-9</b>	<b>9-2875-9</b>	<b>9-2876-9</b>
<b>Magnet Frame Armature</b>				
Lower magnet frame	④	④	④	④
Upper magnet frame	④	④	④	④

#### Notes

- ① These modifications are generally available in kit form at lower cost. See specific product sections for kit listings.
- ② The T16 modifications are only available on C306 overloads and the following three-pole devices: CN15, CN55, AN16, AN56 and AN700 (separate winding only). The 45 mm and 65 mm frames (NEMA Size 0–2) reversing devices (CN55B, CN55D, CN55G, AN56B, AN56D, AN56G, AN700 and AN700G) with the T16 modification are supplied without crossover wires.
- ③ CN35A = Size 00, CN35B and CN35D = Size 0, CN35G = Size 2, CN35K = Size 3, CN35N = Size 4, and CN35S = Size 5.
- ④ Replace with complete contactor.

For Catalog Numbers AN16, AN30, AN40, AN56, AN70, AN80, AN800, CN15, CN35 ① and CN55 Contactors and Starters (Size 1, 2)

Description	NEMA Size 1		NEMA Size 2		NEMA Size 3
	Series A1 Part No.	Series B1 Part No.	Series A1 Part No.	Series B1 Part No.	
<b>Renewal Parts Publication Number</b>	20861	22177	20861	22177	20426
<b>Contact Kits</b>					
Two-pole	6-65	6-65	6-65-7	6-65-7	6-43-5
Three-pole	6-65-2	6-65-2	6-65-8	6-65-8	6-43-6
Four-pole	6-65-9	6-65-9	6-65-15	6-65-15	—
Five-pole	6-65-10	6-65-10	6-65-16	6-65-16	—
<b>Magnet Coils</b>					
	<b>Coil Suffix</b>				
120V 60 Hz or 110V 50 Hz	<b>A</b>	9-3285-1	9-3285-1	9-3285-1	9-2756-1 KIT
240V 60 Hz or 220V 50 Hz	<b>B</b>	9-2703-2 KIT	9-2703-2 KIT	9-2703-2 KIT	9-2756-2 KIT
480V 60 Hz or 440V 50 Hz	<b>C</b>	9-2703-3 KIT	9-2703-3 KIT	9-2703-3 KIT	9-2756-3 KIT
600V 60 Hz or 550V 50 Hz	<b>D</b>	9-2703-4 KIT	9-2703-4 KIT	9-2703-4 KIT	9-2756-4 KIT
208V 60 Hz	<b>E</b>	9-2703-9 KIT	9-2703-9 KIT	9-2703-9 KIT	9-2756-5 KIT
277V 60 Hz	<b>H</b>	9-2703-7 KIT	9-2703-7 KIT	9-2703-7 KIT	9-2756-9 KIT
208/240V 60 Hz	<b>J</b>	—	—	—	—
240V 50 Hz	<b>K</b>	9-2703-14 KIT	9-2703-14 KIT	9-2703-14 KIT	9-2756-13 KIT
380–415V 50 Hz	<b>L</b>	9-2703-8 KIT	9-2703-8 KIT	9-2703-8 KIT	—
380V 50 Hz	<b>L</b>	—	—	—	9-2756-12 KIT
415V 50 Hz	<b>M</b>	—	—	—	9-2756-8 KIT
550V 50 Hz	<b>N</b>	—	—	—	9-2756-14 KIT
24V 60 Hz–24V 50 Hz	<b>T</b>	—	—	—	—
24V 60 Hz	<b>T</b>	9-2703-6 KIT	9-2703-6 KIT	9-2703-6 KIT	9-2756-6 KIT
24V 50 Hz	<b>U</b>	9-2703-12 KIT	9-2703-12 KIT	9-2703-12 KIT	9-2756-11 KIT
32V 50 Hz	<b>V</b>	9-2703-10 KIT	9-2703-10 KIT	9-2703-10 KIT	9-2756-10 KIT
48V 60 Hz	<b>W</b>	9-2703-11 KIT	9-2703-11 KIT	9-2703-11 KIT	9-2756-15 KIT
48V 50 Hz	<b>Y</b>	9-2703-13 KIT	9-2703-13 KIT	9-2703-13 KIT	9-2756-7 KIT
<b>Magnet Frame Armature</b>					
Lower magnet frame		17-18200	17-18200	17-18200	17-8955-2 KIT
Upper magnet frame		48-1936	48-1936	48-1936	48-1902 KIT

**Note**

① CN35A = Size 00, CN35B and CN35D = Size 0, CN35G = Size 2, CN35K = Size 3, CN35N = Size 4, and CN35S = Size 5.

# 2.1

## NEMA Contactors and Starters

### Freedom Series

For a complete listing of parts, refer to the Renewal Parts Publication Number referenced below.

2

For Catalog Numbers AN16, AN30, AN40, AN56, AN70, AN80, AN800, CN15, CN35 <sup>①</sup> and CN55 Contactors and Starters (Size 4, 5, 6)

Description	NEMA Size 4		NEMA Size 5		NEMA Size 6		
	Series A1 Part No.	Series B1 Part No.	Series A1 Part No.	Series B1 Part No.	Contactors and Starter Series A1, Starter Series B1 Part No.	Contactors and Starter Series B1, Starter Series C1 Part No.	
<b>Renewal Parts Publication Number</b>	20428	20428	20429	20429	20146	23349	
<b>Contact Kits</b>							
Two-pole	6-44	6-26	6-45	6-45	6-601-2	—	
Three-pole	6-44-2	6-26-2	6-45-2	6-45-2	6-601	6-648	
<b>Magnet Coils</b>							
	<b>Coil Suffix</b>						
120V 60 Hz or 110V 50 Hz	A	9-1891-1 KIT	9-1891-1 KIT	9-1891-1 KIT	9-1891-1 KIT	9-2698	9-3006
240V 60 Hz or 220V 50 Hz	B	9-1891-2 KIT	9-1891-2 KIT	9-1891-2 KIT	9-1891-2 KIT	9-2698-2	9-3006-2
480V 60 Hz or 440V 50 Hz	C	9-1891-3 KIT	9-1891-3 KIT	9-1891-3 KIT	9-1891-3 KIT	9-2698-3	9-3006-3
600V 60 Hz or 550V 50 Hz	D	9-1891-4 KIT	9-1891-4 KIT	9-1891-4 KIT	9-1891-4 KIT	9-2698-4	9-3006-4
208V 60 Hz	E	9-1891-13 KIT	9-1891-13 KIT	9-1891-13 KIT	9-1891-13 KIT	9-2698-5	—
277V 60 Hz	H	9-1891-26 KIT	9-1891-26 KIT	9-1891-26 KIT	9-1891-26 KIT	—	—
208/240V 60 Hz	J	—	—	—	—	—	—
240V 50 Hz	K	9-1891-20 KIT	9-1891-20 KIT	9-1891-20 KIT	9-1891-20 KIT	—	—
380–415V 50 Hz	L	—	—	—	—	9-2698-6	9-3006-7
380V 50 Hz	L	9-1891-14 KIT	9-1891-14 KIT	9-1891-14 KIT	9-1891-14 KIT	—	—
415V 50 Hz	M	9-1891-21 KIT	9-1891-21 KIT	9-1891-21 KIT	9-1891-21 KIT	—	—
550V 50 Hz	N	9-1891-8 KIT	9-1891-8 KIT	9-1891-8 KIT	9-1891-8 KIT	—	—
24V 60 Hz–24V 50 Hz	T	—	—	—	—	—	9-3006-8
24V 60 Hz	T	9-1891-15 KIT	9-1891-15 KIT	9-1891-15 KIT	9-1891-15 KIT	—	—
24V 50 Hz	U	9-1891-16 KIT	9-1891-16 KIT	9-1891-16 KIT	9-1891-16 KIT	—	—
48V 60 Hz	W	—	—	—	—	9-2698-8	9-3006-9
48V 50 Hz	Y	9-1891-18 KIT	9-1891-18 KIT	9-1891-18 KIT	9-1891-18 KIT	—	—
<b>Overload Relays</b>							
For replacement on existing starters three-pole—ambient compensated bimetallic	10-6530-4	10-6530-4	C306DN3B	C306DN3B	C306DN3B	C306DN3B	C306DN3B
<b>Current Transformer</b>	—	—	42-3564	42-3564	42-3598	42-3598	—
<b>Magnet Frame Armature <sup>②</sup></b>							
Lower Magnet Frame	48-1030-2	48-1030-2	48-1030-2	48-1030-2	—	—	—
Upper Magnet Frame	48-1029-4	48-1029-4	48-1029-4	48-1029-4	—	—	—

### Feeder Group Renewal <sup>③</sup>

Volts	Hertz	NEMA Size 4		NEMA Size 5		NEMA Size 6	
		Series A1	Series B1	Series A1	Series B1	Contactors and Starter Series A1, Starter Series B1	Contactors and Starter Series B1, Starter Series C1
110–120	50/60	—	—	—	—	9-2705	9-3007
220–240	50/60	—	—	—	—	9-2705-2	9-3007-2
440–480	50/60	—	—	—	—	9-2705-3	9-3007-3
550–600	50/60	—	—	—	—	9-2705-4	9-3007-4
208	50/60	—	—	—	—	9-2705-5	9-3007-5
380–415	50/60	—	—	—	—	9-2705-6	9-3007-7
48–52	50/60	—	—	—	—	9-2705-8	9-3007-9
24	50/60	—	—	—	—	9-2705-9	9-3007-8

#### Notes

<sup>①</sup> CN35A = Size 00, CN35B and CN35D = Size 0, CN35G = Size 2, CN35K = Size 3, CN35N = Size 4, and CN35S = Size 5.

<sup>②</sup> Consult factory.

<sup>③</sup> Voltage ratings of the main coils must match those of the feeder group for proper operation of the starter/contactors.

For a complete listing of parts, refer to the Renewal Parts Publication Number referenced below.

For Catalog Numbers AN16, AN30, AN40, AN56, AN70, AN80, AN800, CN15, CN35 <sup>①</sup> and CN55 Contactors and Starters (Size 7, 8)

Description	NEMA Size 7		NEMA Size 8	
	Series A1 Part No.	Series B1 Part No.	Series A1 Part No.	Series B1 Part No.
<b>Renewal Parts Publication Number</b>	20848	20848	20849	20849
<b>Contact Kits</b>				
Two-pole	—	—	—	—
Three-pole	6-613	6-613	6-571	6-571
<b>Magnet Coils</b>				
	<b>Coil Suffix</b>			
120V 60 Hz or 110V 50 Hz	<b>A</b>	9-2698	9-2698	9-2654
240V 60 Hz or 220V 50 Hz	<b>B</b>	9-2698-2	9-2698-2	9-2654-2
480V 60 Hz or 440V 50 Hz	<b>C</b>	9-2698-3	9-2698-3	9-2654-3
600V 60 Hz or 550V 50 Hz	<b>D</b>	9-2698-4	9-2698-4	9-2654-4
208V 60 Hz	<b>E</b>	9-2698-5	9-2698-5	9-2654-6
277V 60 Hz	<b>H</b>	—	—	—
208/240V 60 Hz	<b>J</b>	—	—	—
240V 50 Hz	<b>K</b>	—	—	—
380–415V 50 Hz	<b>L</b>	—	—	—
380V 50 Hz	<b>L</b>	9-2698-6	9-2698-6	9-2654-5
415V 50 Hz	<b>M</b>	—	—	—
550V 50 Hz	<b>N</b>	—	—	—
24V 60 Hz–24V 50 Hz	<b>T</b>	—	—	—
24V 60 Hz	<b>T</b>	—	—	—
24V 50 Hz	<b>U</b>	—	—	—
32V 50 Hz	<b>V</b>	—	—	—
48V 60 Hz	<b>W</b>	—	—	—
48V 50 Hz	<b>Y</b>	—	—	—
<b>Overload Relays</b>				
For replacement on existing starters three-pole—ambient compensated bimetallic	C306DN3B	C306DN3B	C306DN3B	C306DN3B
<b>Current Transformer</b>	42-3598-2	42-3598-2	42-3598-3	42-3598-3
<b>Magnet Frame Armature <sup>②</sup></b>				
Lower magnet frame	—	—	—	—
Upper magnet frame	—	—	—	—

**Notes**

<sup>①</sup> CN35A = Size 00, CN35B and CN35D = Size 0, CN35G = Size 2, CN35K = Size 3, CN35N = Size 4, and CN35S = Size 5.

<sup>②</sup> Consult factory.



Feeder Group Renewal <sup>①</sup>

2

Volts	Hertz	NEMA Size 7		NEMA Size 8	
		Series A1	Series B1	Series A1	Series B1
110–120	50/60	9-2705	9-2705	—	—
220–240	50/60	9-2705-2	9-2705-2	—	—
440–480	50/60	9-2705-3	9-2705-3	—	—
550–600	50/60	9-2705-4	9-2705-4	—	—
208	50/60	9-2705-5	9-2705-5	—	—
380–415	50/60	9-2705-6	9-2705-6	—	—
48–52	50/60	9-2705-8	9-2705-8	—	—
120	50/60	—	—	9-2664	9-2664
240	50/60	—	—	9-2664-2	9-2664-2
480	50/60	—	—	9-2664-3	9-2664-3
600	50/60	—	—	9-2664-4	9-2664-4
380	50/60	—	—	9-2664-5	9-2664-5
208	50/60	—	—	9-2664-6	9-2664-6
415	50/60	—	—	9-2664-7	9-2664-7
110	50/60	—	—	9-2664-8	9-2664-8
220	50/60	—	—	9-2664-9	9-2664-9
550	50/60	—	—	9-2664-10	9-2664-10
440	50/60	—	—	9-2664-11	9-2664-11

## Technical Data and Specifications

All data is based on a standard contactor with no auxiliary devices and a 120 Vac or 24 Vdc magnet coil. Coil data has a  $\pm 5\%$  range depending on the application, therefore specific data may vary.

## Coil Data Notes

P.U.	Pick-up time is the average time taken from closing of the coil circuit to main contact touch
D.O.	Drop-out time is the average time taken from opening of the coil circuit to main contact separation
Cold	Coil data with a cold coil
Hot	Coil data with a hot coil

**Note**

<sup>①</sup> Voltage ratings of the main coils must match those of the feeder group for proper operation of the starter/contactator.

### Specifications—Sizes 00–3

Description	Contactor Catalog Number/Size				
	CN15A NEMA Size 00	CN15B NEMA Size 0	CN15D NEMA Size 1	CN15G NEMA Size 2	CN15K NEMA Size 3
<b>Configuration</b>					
Number of poles	2, 3, 4	2, 3	2, 3, 4, 5	2, 3, 4, 5	2, 3
Auxiliary contacts, standard	4th pole NO (1)	Side NO (1)	Side NO (1)	Side NO (1)	Side NO (1)
Add-on auxiliary contacts	Top (4) or side (4)	Top (4) or side (3)	Top (4) or side (3)	Top (4) or side (3)	Left side (4) or right side (3)
Frame size	45 mm	45 mm	65 mm	65 mm	90 mm
Maximum voltage rating	600 Vac	600 Vac	600 Vac	600 Vac	600 Vac
Continuous ampere ratings (I)	9A	18A	27A	45A	90A
<b>Maximum Horsepower (hp)</b>					
Single-phase					
115V	1/3	1	2	3	7-1/2
230V	1	2	3	7-1/2	15
Three-phase					
200V	1-1/2	3	7-1/2	10	25
230V	1-1/2	3	7-1/2	15	30
460V	2	5	10	25	50
575V	2	5	10	25	50
<b>AC Magnet Coil Data</b>					
Pick-up volts—cold	85%	85%	85%	85%	85%
Pick-up volts—hot	85%	85%	85%	85%	85%
Pick-up voltamperes	80	100	230	230	390
Pick-up watts	49	65	95	95	112
Sealed voltamperes	7.5	10	28	28	49.8
Sealed watts	2.4	3.1	7.8	7.8	13
Drop-out volts—cold	75%	75%	75%	75%	75%
Drop-out volts—hot	75%	75%	75%	75%	75%
Maximum operation rate—ops/hour	12,000	12,000	12,000	12,000	7,200
Pick-up time (ms)	12	12	20	20	14
Drop-out time (ms)	12	12	14	14	11
Coil operating range % of rated voltage	-15% to +10%	-15% to +10%	-15% to +10%	-15% to +10%	-15% to +10%
DC magnet coil data	For DC magnet coils (and coil data), see Accessories, <b>Pages V5-T2-28 and V5-T2-29.</b>	For DC magnet coils (and coil data), see Accessories, <b>Pages V5-T2-28 and V5-T2-29.</b>	For DC magnet coils (and coil data), see Accessories, <b>Pages V5-T2-28 and V5-T2-29.</b>	For DC magnet coils (and coil data), see Accessories, <b>Pages V5-T2-28 and V5-T2-29.</b>	For DC magnet coils (and coil data), see Accessories, <b>Pages V5-T2-28 and V5-T2-29.</b>
Operating temperature	-20° to 65°C	-20° to 65°C	-20° to 65°C	-20° to 65°C	-20° to 65°C
Maximum operating altitude (ft)	6000	6000	6000	6000	6000
Mechanical life	20,000,000	20,000,000	10,000,000	10,000,000	6,000,000
<b>Electrical Life (480V/60 Hz)</b>					
AC-3	4,000,000	3,000,000	5,000,000	3,500,000	1,700,000
AC-4	90,000	85,000	200,000	62,000	80,000
<b>Wire Range</b>					
Power terminals	12–16 stranded, 12–14 solid Cu	8–16 stranded, 10–14 solid Cu	8–14 stranded or solid Cu	2–14 (upper) and/or 6–14 (lower) stranded or solid Cu	1/0–14 Cu
Control terminals	12–16 stranded, 12–14 solid Cu	12–16 stranded, 12–14 solid Cu	12–16 stranded, 12–14 solid Cu	12–16 stranded, 12–14 solid Cu	12–16 stranded, 12–14 solid Cu
Power terminal torque	7	15	20	40 (14–8 AWG)	35 (14–10 AWG)
Line and load—lb-in				45 (6–4 AWG)	40 (8 AWG)
				50 (3 AWG)	45 (6–4 AWG)
					50 (3–1/0 AWG)
Auxiliary contact rating	A600, P300	A600, P300	A600, P300	A600, P300	A600, P300

# 2.1

## NEMA Contactors and Starters

### Freedom Series

#### Specifications—Sizes 4–8

2

Description	Contactor Catalog Number/Size				
	CN15N NEMA Size 4	CN15S NEMA Size 5	CN15T NEMA Size 6	CN15U NEMA Size 7	CN15V NEMA Size 8
<b>Configuration</b>					
Number of poles	2, 3	2, 3	3	3	3
Auxiliary contacts, standard	Side NO (1)	Side NO (1)	Top left 2NO/2NC (1)	Top left 2NO/2NC (1)	Side 2NO/NC (1)
Add-on auxiliary contacts	Left side (3) or right side (4)	Left side (3) or right side (4)	Top right 2NO/2NC (1)	Top right 2NO/2NC (1)	NO/NC (2)
Frame size	180 mm	180 mm	280 mm	280 mm	334 mm
Maximum voltage rating	600 Vac	600 Vac	600 Vac	600 Vac	600 Vac
Continuous ampere ratings (I)	135A	270A	540A	810A	1215A
<b>Maximum Horsepower (hp)</b>					
Single-phase					
115V	—	—	—	—	—
230V	—	—	—	—	—
Three-phase					
200V	40	75	150	200	400
230V	50	100	200	300	450
460V	100	200	400	600	900
575V	100	200	400	600	900
<b>AC Magnet Coil Data</b>					
Pick-up volts—cold	85%	85%	85%	85%	85%
Pick-up volts—hot	85%	85%	85%	85%	85%
Pick-up voltamperes	1158	1158	1600	1600	2450
Pick-up watts	240	240	1345	1345	2060
Sealed voltamperes	100	100	25	25	75
Sealed watts	27.2	27.2	22	22	60
Drop-out volts—cold	75%	75%	①	①	①
Drop-out volts—hot	75%	75%	①	①	①
Maximum operation rate—ops/hour	2400	2400	N/A	N/A	N/A
Pick-up time (ms)	28	25	105	105	70
Drop-out time (ms)	14	13	200	200	50
Coil operating range % of rated voltage	–15% to +10%	–15% to +10%	–15% to +10%	–15% to +10%	–15% to +10%
DC magnet coil data	For DC magnet coils (and coil data), see Accessories, <b>Pages V5-T2-28 and V5-T2-29.</b>	For DC magnet coils (and coil data), see Accessories, <b>Pages V5-T2-28 and V5-T2-29.</b>	For DC magnet coils (and coil data), see Accessories, <b>Pages V5-T2-28 and V5-T2-29.</b>	For DC magnet coils (and coil data), see Accessories, <b>Pages V5-T2-28 and V5-T2-29.</b>	For DC magnet coils (and coil data), see Accessories, <b>Pages V5-T2-28 and V5-T2-29.</b>
Operating temperature	–20° to 65°C	–20° to 65°C	–20° to 65°C	–20° to 65°C	–20° to 65°C
Maximum operating altitude (ft)	6000	6000	6000	6,000	6000
Mechanical life	5,000,000	5,000,000	5,000,000	5,000,000	5,000,000
<b>Electrical Life (480V/60 Hz)</b>					
AC-3	800,000	500,000	590,000	450,000	420,000
AC-4	70,000	34,000	7400	5000	4200
<b>Wire Range</b>					
Power terminals	Open—3/0–8 Cu; Enclosed—250 kcmil–6 Cu/Al	750 kcmil—2 or (2) 250 kcmil—3/0 Cu/Al	(2) 750 kcmil—3/0 Cu/Al	(3) 750 kcmil—3/0 Cu/Al	(4) 750 kcmil—1/0 Cu/Al
Control Terminals	12–16 stranded, 12–14 solid Cu	12–16 stranded, 12–14 solid Cu	12–16 stranded, 12–14 solid Cu	12–16 stranded, 12–14 solid Cu	12–16 stranded, 12–14 solid Cu
Power terminal torque line and load—lb-in	200	550	550	550	500
Auxiliary contact rating	A600, P300	A600, P300	A600, P300	A600, P300	A600, P300

**Note**

① 20–30% of rated coil voltage.

## Electrical Life—AC-3 and AC-4 Utilization Categories

### Life Load Curves

Eaton’s Freedom Series NEMA contactors have been designed and manufactured for superior life performance in any worldwide application. All testing has been based on requirements as found in NEMA and UL standards and conducted by Eaton. Actual application life may vary depending on environmental conditions and application duty cycle.

### Utilization Categories

The International Electrotechnical Commission (IEC) has developed utilization categories for contactors and auxiliary contacts. The IEC utilization categories are used to define the type of electrical load for estimating electrical life, and do not imply the devices are IEC rated.

AC-1—Non-inductive or slightly inductive loads, such as resistance furnaces and heating.

AC-2—Starting of slip-ring motors.

AC-3—Squirrel cage motors; starting, switching off motors during running.

AC-4—Squirrel cage motors; starting, plugging, inching or jogging.

**Note:** AC-3 tests are conducted at rated device currents and AC-4 tests are conducted at six times rated device currents. All tests have been run at 460V, 60 Hz.

### Contactors Choice

- Decide what utilization category your application is and choose the appropriate curve
- Locate the intersection of the life-load curve of the appropriate contactor with the applications operational current ( $I_o$ ), as found on the horizontal axis
- Read the estimated contact life along the vertical axis in number of operational cycles

### AC-3 and AC-4 Utilization Categories

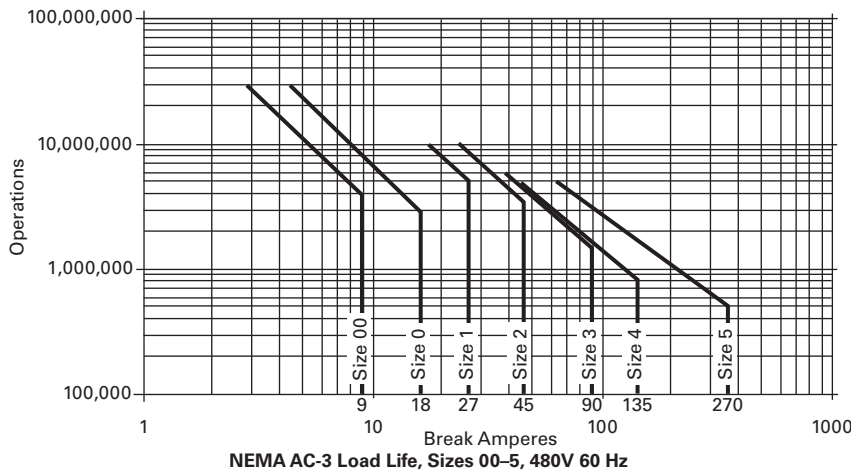

NEMA AC-3 Load Life, Sizes 00-5, 480V 60 Hz

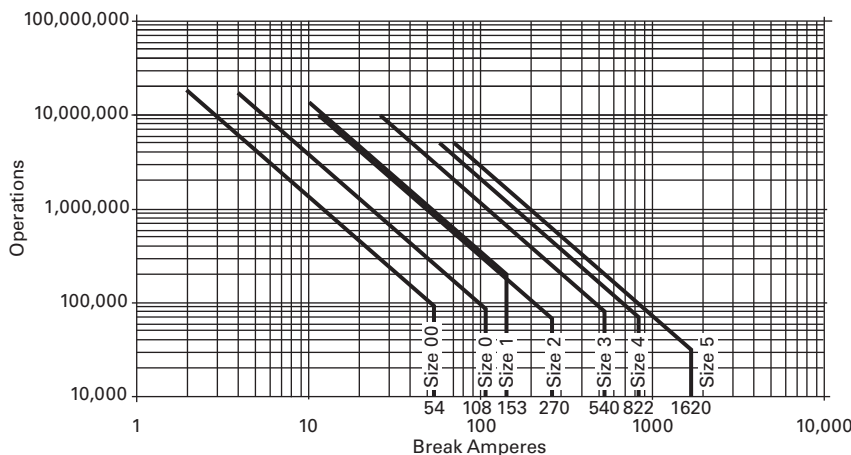

NEMA AC-4 Load Life, Sizes 00-5, 480V 60 Hz

32A Overload—C306DN3B

2



### Relays—Thermal Overload

#### Product Description

C306 Overload Relays are designed for use with CE or CN non-reversing and reversing contactors. Four sizes are available for overload protection up to 144A.

#### Features

- Selectable manual or automatic reset operation
- Interchangeable heater packs adjustable  $\pm 24\%$  to match motor FLA and calibrated for use with 1.0 and 1.15 service factor motors. Heater packs for 32A overload relay will mount in 75A overload relay—useful in derating applications such as jogging
- Class 10 or 20 heater packs
- Load lugs built into relay base
- Bimetallic, ambient compensated operated. Trip free mechanism
- Electrically isolated NO-NC contacts (pull RESET button to test). (Electrical ratings see table on **Page V5-T2-46**)
- Overload trip indication
- Shrouded or fingerproof terminals to reduce possibility of electrical shock

### Contents

<i>Description</i>	<i>Page</i>
Contactors—Non-Reversing and Reversing . . . . .	<b>V5-T2-4</b>
Starters—Three-Phase Non-Reversing and Reversing, Full Voltage . . . . .	<b>V5-T2-10</b>
Starters—Single-Phase Non-Reversing, Full Voltage, Bi-Metallic Overload . . . . .	<b>V5-T2-15</b>
Accessories . . . . .	<b>V5-T2-21</b>
Renewal Parts . . . . .	<b>V5-T2-30</b>
Technical Data and Specifications . . . . .	<b>V5-T2-34</b>
Relays—Thermal Overload	
Product Selection . . . . .	<b>V5-T2-39</b>
Accessories . . . . .	<b>V5-T2-43</b>
Modifications . . . . .	<b>V5-T2-43</b>
Replacement Parts . . . . .	<b>V5-T2-44</b>
Technical Data and Specifications . . . . .	<b>V5-T2-45</b>
Dimensions . . . . .	<b>V5-T2-47</b>
C440/ <i>XT</i> Electronic Overload Relay . . . . .	<b>V5-T2-48</b>

#### Standards and Certifications

- Meets UL 508 single-phasing requirements
- UL listed, CSA certified and NEMA compliance



Product Selection

C306 Thermal Overload Relays

C306DN3B



Contactor

NEMA Size	Maximum Ampere Rating	Number of Poles	Open Type Catalog Number	NEMA 1 Enclosed Catalog Number
00, 0	32 <sup>②</sup>	3	C306DN3B	C306DG3B
1, 2	75 <sup>②</sup>	3	C306GN3B	C306GG3B
3	105 <sup>③</sup>	3	C306KN3	—
4	144 <sup>③</sup>	3	C306NN3	—
5-8 <sup>①</sup>	—	—	—	—

C306GN3B



C306DT3B



Standalone Applications

NEMA Size	Maximum Ampere Rating	Number of Poles	Open Type Catalog Number
00, 0, 1 <sup>④</sup>	32	3	C306DT3B
1 <sup>④</sup>	75	3	C306GT3B
3 <sup>⑤</sup>	105	3	C306KN3
4 <sup>⑤</sup>	144	3	C306NN3
5-8 <sup>⑥</sup>	—	—	—

C306GT3B



Notes

- ① NEMA Sizes 5-8 use the 32A overload in conjunction with CTs.
- ② Series B overload relays have load lugs built into relay base and will only accept Series B heater packs. These relays can be directly attached to contactor or they can be DIN rail or panel mounted using adapter on **Page V5-T2-44**.
- ③ These relays can be panel mounted only.
- ④ Overload relay assembled with mounting adapter for DIN rail or panel mount.
- ⑤ Panel mount only.
- ⑥ NEMA Sizes 5-8 use the 32A overload in conjunction with CTs.

# 2.1

## NEMA Contactors and Starters

### Freedom Series

2

#### Heater Pack Selection

Heater packs H2001B to H2017B and H2101B to H2117B are to be used only with Series B overload relays Catalog Numbers C306DN3B (Part No. 10-7016) and C306GN3B (Part No. 10-7020). The load lugs are built into the overload relay

base to allow load wiring prior to heater pack installation. The previous heater design had integral load lugs. The Series B heater packs are electrically equivalent to the previous heater design. Heaters H2018-3 to H2024-3 have not changed.

#### Starters with Series B Overload Relays ①

NEMA—AN Type		IEC—AE Type	
Size	Series	Size	Series
00-0	<b>C</b>	A-F	<b>C</b>
1-2	<b>B</b>	G-K	<b>B</b>
5	<b>B</b>	G-K	<b>B</b>
6	<b>C</b>	G-K	<b>B</b>
7-8	<b>B</b>	G-K	<b>B</b>

Heater Pack  
H2001B–H2017B



#### Standard Trip—Class 20 Heater

Overload Relay Size	Motor Full Load Ampere Rating				Catalog Number ②
	Dial Position				
	A	B	C	D	
<b>For Use with NEMA Sizes 00-0 Series C, NEMA Sizes 1-2 Series B; IEC Sizes A-F Series C, IEC Sizes G-K Series B</b>					
32A or 75A	0.254	0.306	0.359	0.411	<b>H2001B-3</b>
	0.375	0.452	0.530	0.607	<b>H2002B-3</b>
	0.560	0.676	0.791	0.907	<b>H2003B-3</b>
	0.814	0.983	1.15	1.32	<b>H2004B-3</b>
	1.20	1.45	1.71	1.96	<b>H2005B-3</b>
	1.79	2.16	2.53	2.90	<b>H2006B-3</b>
	2.15	2.60	3.04	3.49	<b>H2007B-3</b>
	3.23	3.90	4.56	5.23	<b>H2008B-3</b>
	4.55	5.50	6.45	7.40	<b>H2009B-3</b>
	6.75	8.17	9.58	11.0	<b>H2010B-3</b>
	9.14	10.8	12.4	14.0	<b>H2011B-3</b>
	14.0	16.9	19.9	22.8	<b>H2012B-3</b>
	18.7	22.7	26.7	30.7	<b>H2013B-3</b>
23.5	28.5	33.5	38.5	<b>H2014B-3</b>	
<b>For Use with NEMA Size 2, IEC Sizes G-K Only, Series B</b>					
75A	29.0	34.0	39.1	44.1	<b>H2015B-3</b>
	39.6	45.5	51.5	57.4	<b>H2016B-3</b>
	53.9	60.9	67.9	74.9	<b>H2017B-3</b>

#### Notes

- ① The series of a starter is the last digit of the listed catalog number. Example: AN16DN0AB.
- ② Heater packs are shipped three to a carton. catalog numbers are for three heater packs.

**Heater Pack  
H2018–H2024**

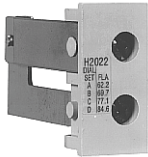

### Standard Trip—Class 20 Heater, continued

Overload Relay Size	Motor Full Load Ampere Rating Dial Position				Catalog Number <sup>①</sup>
	A	B	C	D	
<b>For Use with NEMA Sizes 3–4, IEC Sizes L–N Only—Series A</b>					
105A or 144A	8.0	9.2	10.3	11.5	<b>H2025-3</b>
	11.4	12.8	14.3	15.7	<b>H2026-3</b>
	14.3	15.7	17.4	19.0	<b>H2027-3</b>
	18.0	20.2	22.3	24.5	<b>H2018-3</b>
	24.6	27.6	30.5	33.4	<b>H2019-3</b>
	33.5	37.5	41.5	45.6	<b>H2020-3</b>
	45.7	51.2	56.7	62.1	<b>H2021-3</b>
	62.2	69.7	77.1	84.6	<b>H2022-3</b>
	84.7	95.0	105.0	115.0	<b>H2023-3</b>
	106.0	118.0	131.0	144.0	<b>H2024-3</b>
<b>For Use with Size 5 Starters—Series B and IEC P, R and S with 300/5 CT</b>					
32A <sup>②</sup>	49	59	69	79	<b>H2004B-3</b>
	72	87	103	118	<b>H2005B-3</b>
	107	130	152	174	<b>H2006B-3</b>
	129	156	182	209	<b>H2007B-3</b>
	194	234	274	—	<b>H2008B-3</b>
<b>For Use with Size 6 Starters Only—Series B and IEC T–V with 600/5 CT</b>					
32A <sup>②</sup>	144	174	205	235	<b>H2005B-3</b>
	215	259	304	348	<b>H2006B-3</b>
	258	312	365	419	<b>H2007B-3</b>
	388	468	547	627	<b>H2008B-3</b>
<b>For Use with Size 7 Starters Only—Series B and IEC W–X with 1000/5 CT</b>					
32A <sup>②</sup>	163	197	230	264	<b>H2004B-3</b>
	240	290	342	392	<b>H2005B-3</b>
	358	432	506	580	<b>H2006B-3</b>
	430	520	608	698	<b>H2007B-3</b>
	646	780	912	—	<b>H2008B-3</b>
<b>For Use Size 8 Starters Only—Series B and IEC Z with 1500/5 CT</b>					
32A <sup>②</sup>	244	295	345	396	<b>H2004B-3</b>
	360	435	513	588	<b>H2005B-3</b>
	537	648	759	870	<b>H2006B-3</b>
	645	780	912	1047	<b>H2007B-3</b>
	969	1170	1368	—	<b>H2008B-3</b>

**Notes**

- ① Heater packs are shipped three to a carton, catalog numbers are for three heater packs.
- ② Sizes 5–8 and IEC P–Z use the 32A overload relay with current transformers.



Heater Pack  
H2101B–H2117B

2

## Fast Trip—Class 10 Heater

Overload Relay Size	Motor Full Load Ampere Rating Dial Position				Catalog Number <sup>①</sup>
	A	B	C	D	
<b>For Use with NEMA Sizes 00–0 Series C, NEMA Sizes 1–2 Series B; IEC Sizes A–F Series C, IEC Sizes G–K Series B</b>					
32A or 75A	0.260	0.313	0.367	0.420	H2101B-3
	0.384	0.464	0.543	0.623	H2102B-3
	0.570	0.688	0.806	0.924	H2103B-3
	0.846	1.02	1.20	1.37	H2104B-3
	1.28	1.55	1.83	2.10	H2105B-3
	1.92	2.33	2.74	3.15	H2106B-3
	2.30	2.79	3.28	3.77	H2107B-3
	3.38	4.10	4.82	5.54	H2108B-3
	4.96	6.03	7.09	8.16	H2109B-3
	7.07	8.58	10.1	11.6	H2110B-3
	9.60	11.2	12.8	14.4	H2111B-3
	14.4	17.5	20.7	23.8	H2112B-3
	18.7	21.8	25.0	28.1	H2113B-3
23.5	27.3	31.0	34.8	H2114B-3	
<b>For Use with Size 2, IEC Sizes G–K Only—Series B</b>					
75A	28.3	32.6	37.0	41.3	H2115B-3
	36.6	42.3	48.1	53.8	H2116B-3
	53.8	60.8	67.9	74.9	H2117B-3
<b>For Use with Size 5 Starters Only—Series B and IEC P, R and S with 300/5 CT</b>					
32A <sup>②</sup>	51	61	72	82	H2104B-3
	77	93	110	126	H2105B-3
	115	140	164	189	H2106B-3
	138	167	197	226	H2107B-3
	203	246	289	—	H2108B-3
<b>For Use with Size 6 Starters Only—Series B and IEC T–V with 600/5 CT</b>					
32A <sup>②</sup>	154	186	220	252	H2105B-3
	230	280	329	378	H2106B-3
	276	335	394	452	H2107B-3
	406	492	578	—	H2108B-3
<b>For Use with Size 7 Starters Only—Series B and IEC W–X with 1000/5 CT</b>					
32A <sup>②</sup>	169	204	240	274	H2104B-3
	256	310	366	420	H2105B-3
	384	466	543	630	H2106B-3
	460	558	656	754	H2107B-3
	676	820	—	—	H2108B-3
<b>For Use with Size 8 Starters Only—Series B and IEC Z with 1500/5 CT</b>					
32A <sup>②</sup>	254	306	360	411	H2104B-3
	384	465	549	630	H2105B-3
	576	699	822	945	H2106B-3
	690	837	984	1131	H2107B-3
	1014	1230	—	—	H2108B-3

**Notes**

- ① Heater packs are shipped three to a carton. catalog numbers are for three heater packs.  
 ② Sizes 5–8 and IEC P–Z use the 32A overload relay with current transformers.

**Accessories**

**DIN Rail and Panel Mounting Adapter**

These adapters are required when component overload relays are to be separately mounted. The terminal base adapter includes line terminals and connects with the overload relays on **Page V5-T2-39**.

**C306TB1**



**DIN Rail and Panel Mounting Adapter**

Description	Catalog Number
For 32A overload relay	<b>C306TB1</b>
For 75A overload relay	<b>C306TB2B</b> ①

**Modifications**

**C306 Thermal Overload Relays with Mounting Adapter**

Consists of a thermal overload relay mounted to a terminal base adapter—permits fast and easy installation.

**C306 Thermal Overload Relays with Mounting Adapter**

Description	Catalog Number
C306DN3B + C306TB1	<b>C306DT3B</b>
C306GN3B + C306TB2B	<b>C306GT3B</b>

**Locking Cover for Overload Relay—C306 Only**

Snap-on transparent or opaque plastic panel for covering access port to the overload relay trip setting dial—helps prevent accidental or unauthorized changes to trip and reset setting.

**Overload Relay Cover**



**Locking Cover for Overload Relay—C306 Only**

Description	Min. Order Qty. (Std. Pkg.)	Catalog Number
Clear cover, no accessibility	50	<b>C320PC3</b>
Gray cover, no accessibility with auto only nib	50	<b>C320PC4</b>
Gray cover, no accessibility with manual only nib	50	<b>C320PC5</b>
Gray cover with FLA dial accessibility, A, B, C, D positions and auto only nib	50	<b>C320PC6</b>
Gray cover with FLA dial accessibility, A, B, C, D positions and manual only nib	50	<b>C320PC7</b>

**Note**

① This Series B adapter will accept Series A or B overload relays (C306GN3 or C306GN3B), C306TB2 can only be used with C306GN3.

# 2.1

## NEMA Contactors and Starters

### Freedom Series

#### Replacement Parts

2

##### Heater Pack Replacement

The heater pack series is determined by the 6th character of the catalog number. Series A or prior heater packs (identified by either “A” or “-” as the 6th character) have built-in load lugs. Series B or later heater

packs do not (load lugs are on overload relay). Replacement of Series A or earlier heater packs with Series B or later heater packs, requires the one time addition of Lug Adapter Kit C306KAL1-3B to the Series A1 overload relay.

##### Superseded Series A Heater Pack



##### Series B Heater Pack



#### Heater Pack Replacement Requirements

Existing Heater Pack Catalog Numbers	Replacement Product Required
H2001-3–H2013-3 H2001A-3–H2013A-3	Lug adapter kit C306KAL1-3B and Series B heater pack
H2001B-3–H2013B-3	Series B heater pack
H2014-3 H2014A-3	Replace with lug adapter kit C306KAL1-3B and Series B heater pack
H2014B-3	Series B heater pack
H2015-3–H2017-3	Replace with heater pack chosen from table below
H2015A-3–H2017A-3	Replace with lug adapter kit C306KAL1-3B and Series B heater pack
H2015B-3–H2017B-3	Series B heater pack

#### Heater Pack Ratings

##### Motor Full Load Ampere Rating

Dial Position	A	B	C	D	Order Heater Pack Catalog Number
	29.0	32.5	36.0	39.5	H2015B-3
	39.6	44.3	49.1	53.8	H2016B-3
	53.9	60.4	66.8	74.9	H2017B-3

##### Overload Relay Lug Adapter Kit

##### Superseded 32A Series A Overload Relay—C306DN3

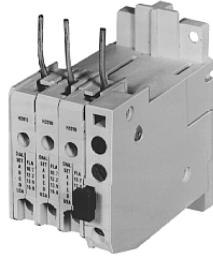

These kits are used in conjunction with Catalog Numbers H2001B–H2014B or H2101B–H2114B heater packs as a means of utilizing these Series B heater packs in Catalog Numbers C306DN3 and C306GN3 Series A1 overload relays. The kit consists of three lug

##### Superseded 75A Series A Overload Relay—C306GN3

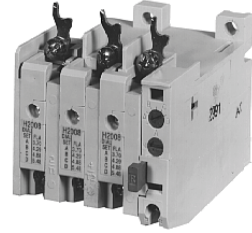

adapters and installation instructions. When installing Series B heater packs plus lug adapters in Series A overload relays, refer to heater pack FLA adjustment tables originally supplied with equipment (also supplied with kit).

##### C306KAL1



#### Overload Relay Lug

Description	Catalog Number
Series A1 overload relay lug adapter kit	C306KAL1-3B

##### Overload Relay Replacement—Series A Only

When replacing a Catalog Number C306DN3 (Part No. 10-6044) or C306GN3 (10-6319) Series A overload relay on a starter, order a Series B overload relay and Series B heater packs.

**Technical Data and Specifications**

**Operation**

**C306 Overload Relay Setting**

For motors having a 1.15 service factor, rotate the FLA (Full Load Amperes) adjustment dial to correspond to the motor's FLA rating.

Estimate the dial position when the motor FLA falls between two letter values as shown in the example.

For motors having a 1.0 service factor, rotate the FLA dial one-half position counterclockwise (CCW).

**FLA Dial Adjustment**

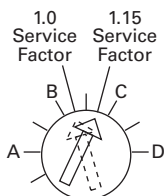

Example of 12.0 FLA setting for heater pack number H2011B showing position for 1.0 or 1.15 service factor motors.

The overload relay is factory set at M for manual reset operation. For automatic reset operation, turn the reset adjustment dial to the A position as shown in the illustration.

Automatic reset is not intended for two-wire control devices.

**Manual/Automatic Reset**

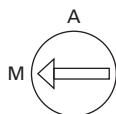

Example of setting for manual reset.

**Test for Trip Indication**

To test overload relay for trip indication when in manual reset, pull out the blue reset button. An orange flag will appear indicating that the device has tripped. Push reset button in to reset.

**Warning**—To provide continued protection against fire or shock hazard, the complete overload relay must

be replaced if burnout of the heater element occurs.

**General**

“Overload relays are provided to protect motors, motor control apparatus and motor-branch circuit conductors against excessive heating due to motor overloads and failure to start. This definition does not include: 1) motor circuits over 600V, 2) short circuits, 3) ground faults and 4) fire pump control.” (NEC Art. 430-31)

**Time Current Characteristics**

The time-current characteristics of an overload relay is an expression of performance which defines its operating time at various multiples of its current setting. Tests are run at Underwriters Laboratories (UL) in accordance with NEMA Standards and the NEC. UL requires:

- When tested at 100 percent of its current rating, the overload relay shall trip ultimately

- When tested at 200 percent of its current rating, the overload relay shall trip in not more than 8 minutes
- When tested at 600 percent of the current rating, the overload relay shall trip in not more than 10 or 20 seconds, depending on the Class of the relay

“Current Rating” is defined as the minimum current at which the relay will trip. Per NEC, an overload must ultimately trip at 125% of FLA current (heater) setting for a 1.15 service factor motor and 115% FLA for a 1.0 service factor motor.

“Current Setting” is defined as the FLA of the motor and thus the overload heater pack setting.

Example: 600% of current rating is defined as 750% (600 x 1.25) of FLA current (heater) setting for a 1.15 service factor motor. A 10A heater setting must trip in 20 seconds or less at 75A motor current for a Class 20 relay.

**Class 10 and Class 20 Trip Curves**

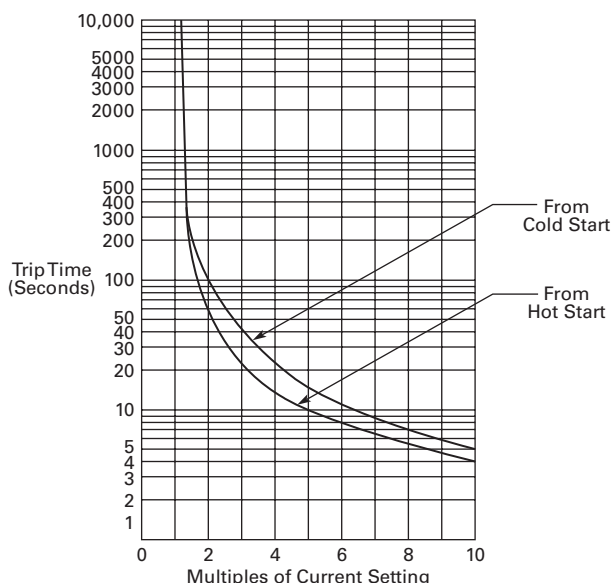

Class 10 Overload Relay 25C Open Rating

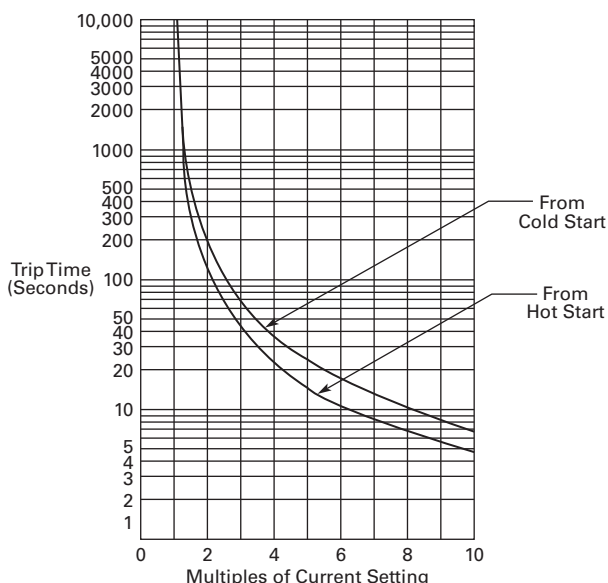

Class 20 Overload Relay 25C Open Rating

# 2.1

## NEMA Contactors and Starters

### Freedom Series

2

#### Wire (75°C) Sizes—AWG or kcmil—NEMA Sizes 00–2, IEC A–K—Open

##### Power Terminals—Line

IEC Size	NEMA Size	Cu Only
A, B, C	00	12–16 stranded, 12–14 solid
D, E, F	0	8–16 stranded, 10–14 solid
	1	8–14 stranded or solid
G, H, J, K	2	3–14 (upper) and/or 6–14 (lower) stranded or solid ①

##### Power Terminals—Load—Cu Only (Stranded or Solid)

Catalog Number	Terminal	Wire Size
C306DN3B	32A	14–6 AWG
C306GN3B	75A	14–2 AWG

##### Control Terminals—Cu Only

12–16 AWG stranded, 12–14 AWG solid

#### Wire (75°C) Sizes—AWG or kcmil—NEMA Sizes 3–8, IEC L–N—Open

##### Power Terminals—Line and Load

IEC Size	NEMA Size	Wire Size
L	3	1/0–14 Cu/Al
M	—	14–2/0 Cu/Al
N	—	3/0–8 Cu/Al
—	4	Open—3/0–8 Cu Enclosed—250 kcmil—6 Cu/Al
—	5	750 kcmil—2 or (2) 250 kcmil—3/0 Cu/Al
	6–7	(2) 750 kcmil—3/0 Cu/Al
	8	(2) 750 kcmil—1/0 Cu/Al

##### Control Terminals—Cu Only

12–16 AWG stranded, 12–14 AWG solid

##### Power Terminal Torque Line and Load Terminals

Catalog Number	Terminal	Torque in lb-in
C306DT3B	32A	20
C306GT3B	75A	35 (14–10 AWG) 40 (8 AWG) 45 (6–4 AWG) 50 (3–2 AWG)
C306KN3 (socket head screw)	105A	120 (3/16) 200 (1/4) 250 (5/16)
C306NN3 (socket head screw)	144A	120 (3/16) 200 (1/4) 250 (5/16)
C306NN3 (slotted head screw)		35 (14–10 AWG) 40 (8 AWG) 45 (6–4 AWG) 50 (3–1/0 AWG)

#### Plugging and Jogging Service Horsepower Ratings ②

NEMA Size	200V	230V	460V	575V
00	—	1/2	1/2	1/2
0	1-1/2	1-1/2	2	2
1	3	3	5	5
2	7-1/2	10	15	15
3	15	20	30	30
4	25	30	60	60
5	60	75	150	150
6	125	150	300	300

#### Overload Relay UL/CSA Contact Ratings Control Circuit ③

AC Volts	120V	240V	480V	600V
<b>NC Contact B600</b>				
Make and break amperes	30	15	7.5	6
Break amperes	3	1.5	0.75	0.6
Continuous amperes	5	5	5	5
<b>NO Contact C600</b>				
Make and break amperes	15	7.5	3.375	3
Break amperes	1.5	0.75	0.375	0.3
Continuous amperes	2.5	2.5	2.5	2.5

##### Notes

- ① Two compartment box lug.
- ② Maximum horsepower where operation is interrupted more than 5 times per minute or more than 10 times in a 10 minute period. NEMA standard ICS 2-1993 table 2-4-3.
- ③ DC ratings cover Freedom Series coils only.

### Dimensions

Approximate Dimensions in Inches (mm)

#### Stand-Alone Overload Relays

##### 32A and 75A Sizes—C306DT38 and C306GT3B

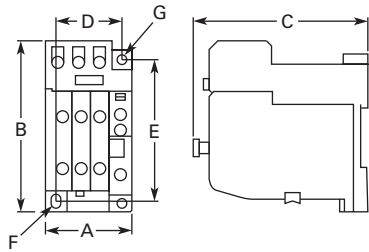

##### 105A and 144A Sizes—C306KN38 and C306NN3B

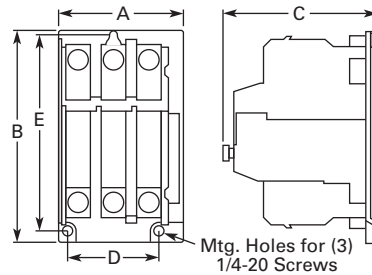

### Dimensions and Shipping Weights

Ampere Size	Wide A	High B	Deep C	Mounting D	E	F (Slot)	G (Hole)	Shipping Weight Lbs (kg)
32A	1.77 (45.0)	4.13 (104.9)	3.69 (93.7)	1.36 (34.5)	3.74 (95.0)	0.18 x 0.30 (4.6 x 7.6)	0.18 (4.6) dia.	0.8 (0.4)
75A	2.54 (64.5)	4.69 (119.1)	3.74 (95.0)	2.00 (50.8)	3.45 (87.6)	0.22 x 0.26 (5.6 x 6.6)	0.21 (5.3) dia.	1.4 (0.6)
105 and 144A	4.00 (101.6)	7.17 (182.1)	4.91 (124.7)	3.00 (76.2)	6.62 (168.1)	—	—	4.0 (1.8)

C440/XT Electronic Overload Relay

2



### C440/XT Electronic Overload Relay

#### Product Description

Eaton's new electronic overload relay (EOL) is the most compact, high-featured, economical product in its class. Designed on a global platform, the new EOL covers the entire power control spectrum including NEMA, IEC and DP contactors. The NEMA and DP versions are offered with the *C440* designation while the IEC offering has the *XT* designation. The electronic design provides reliable, accurate and value driven protection and communications capabilities in a single compact device. It is the flexible choice for any application requiring easy-to-use, reliable protection.

Eaton has a long history of innovations and product development in motor control and protection, including both traditional NEMA, as well as IEC control. It was from this experience that the C440 was developed, delivering new solutions to meet today's demands.

C440 is a self-powered electronic overload relay available up to 175A as a self contained unit. With external CTs, C440 can protect motor up to 1500 FLA. Available add-on accessories include remote reset capability and communication modules with I/O for DeviceNet, PROFIBUS, and Modbus.

### Contents

<i>Description</i>	<i>Page</i>
Contactors—Non-Reversing and Reversing . . . . .	<b>V5-T2-4</b>
Starters—Three-Phase Non-Reversing and Reversing, Full Voltage . . . . .	<b>V5-T2-10</b>
Starters—Single-Phase Non-Reversing, Full Voltage, Bi-Metallic Overload . . . . .	<b>V5-T2-15</b>
Accessories . . . . .	<b>V5-T2-21</b>
Renewal Parts . . . . .	<b>V5-T2-30</b>
Technical Data and Specifications . . . . .	<b>V5-T2-34</b>
Relays—Thermal Overload. . . . .	<b>V5-T2-38</b>
C440/XT Electronic Overload Relay	
Standards and Certifications . . . . .	<b>V5-T2-49</b>
Catalog Number Selection . . . . .	<b>V5-T2-50</b>
Product Selection . . . . .	<b>V5-T2-51</b>
Accessories . . . . .	<b>V5-T2-53</b>
Technical Data and Specifications . . . . .	<b>V5-T2-57</b>
Dimensions . . . . .	<b>V5-T2-63</b>

### Features and Benefits

#### Features

- Reliable, accurate, electronic motor protection
- Easy to select, install and maintain
- Compact size
- Flexible, intelligent design
- Global product offering—available with NEMA, IEC and DP power control

#### Size/Range

- Broad FLA range (0.33–1500A)
- Selectable trip class (10A, 10, 20, 30)
- Direct mounting to NEMA, IEC and DP contactors
- Most compact electronic overload in its class

#### Motor Control

- Two B600 alarm (NO) and fault (NC) contacts
- Test/Trip button

#### Motor Protection

- Thermal overload
- Phase loss
- Selectable (ON/OFF) phase unbalance
- Selectable (ON/OFF) ground fault

#### User Interface

- Large FLA selection dial
- Trip status indicator
- Operating mode LED
- DIP switch selectable trip class, phase unbalance and ground fault
- Selectable Auto/Manual reset

#### Feature Options

- Remote reset
  - 120 Vac
  - 24 Vac
  - 24 Vdc
- Tamper-proof cover
- Communications modules
  - Modbus RTU RS-485
  - DeviceNet with I/O
  - PROFIBUS with I/O
  - Modbus RTU with I/O
  - Ethernet IP with I/O
  - Modbus TCP with I/O

### Benefits

#### Reliability and Improved Uptime

- C440 provides the users with peace of mind knowing that their assets are protected with the highest level of motor protection and communication capability in its class
- Extends the life of plant assets with selectable motor protection features such as trip class, phase unbalance and ground fault
- Protects against unnecessary downtime by discovering changes in your system (line/load) with remote monitoring capabilities
- Status LED provides added assurance that valuable assets are protected by indicating the overload operational status

#### Flexibility

- Available with NEMA, IEC and DP contactors
- Improves return on investment by reducing inventory carrying costs with wide FLA adjustment (5:1) and selectable trip class
- Design incorporates built-in ground fault protection thus eliminating the need for separate CTs and modules
- Flexible communication with optional I/O enables easy integration into plant management systems for remote monitoring and control
- Available as an open component and in enclosed control and motor control center assemblies

#### Monitoring Capabilities

- Individual phase currents RMS
- Average three-phase current RMS
- Thermal memory
- Fault indication (overload, phase loss, phase unbalance, ground fault)

#### Safety

- IP 20 rated terminal blocks
- Available in Eaton's industry leading FlashGard MCCs
- Tested to the highest industry standards such as UL, CSA, CE and IEC
- RoHS compliant

#### Standards and Certifications

- UL
- CSA
- CE
- NEMA
- IEC/EN 60947 VDE 0660
- ISO 13849-1 (EN954-1)
- RoHS
- ATEX directive 94/9/EC
- Equipment Group 2, Category 2



### Electronic Overload Education

Description	Definition	Cause	Effect if not Protected	C440/XT Protection
<b>Motor Protection</b>				
Thermal overload	Overload is a condition in which current draw exceeds 115% of the full load amperage rating for an inductive motor.	<ul style="list-style-type: none"> <li>• An increase in the load or torque that is being driven by the motor.</li> <li>• A low voltage supply to the motor causes the current to go high to maintain the power needed.</li> <li>• A poor power factor causing above normal current draw.</li> </ul>	<ul style="list-style-type: none"> <li>• Increase in current draw leads to heat and insulation breakdown, which can cause system failure.</li> <li>• Increase in current can increase power consumption and waste valuable energy.</li> </ul>	<ul style="list-style-type: none"> <li>• Thermal trip behavior is defined by UL, CSA and IEC standards.</li> <li>• Trip class is settable from 10A, 10, 20, 30</li> </ul>
Ground fault	A line to ground fault.	A current leakage path to ground.	An undetected ground fault can burn through multiple insulation windings, ultimately leading to motor failure, not to mention risk to equipment or personnel	Fixed protective setting that takes the starter offline if ground fault current exceeds 50% of the FLA dial setting, that is, if the FLA dial is set to 12A, the overload relay will trip if the ground current exceeds 6A.
Unbalanced phases (voltage and current)	Uneven voltage or current between phases in a three-phase system.	When a three-phase load is powered with a poor quality line, the voltage per phase may be unbalanced.	Unbalanced voltage causes large unbalanced currents and as a result this can lead to motor stator windings being overloaded, causing excessive heating, reduced motor efficiency and reduced insulation life.	Fixed protective setting that takes the starter offline if a phase drops below 50% of the other two phases.
Phase loss—current (single-phasing)	One of the three-phase voltages is not present.	Multiple causes, loose wire, improper wiring, grounded phase, open fuse, and so on.	Single-phasing can lead to unwanted motor vibrations in addition to the results of unbalanced phases as listed above.	Fixed protective setting that takes the starter offline if a phase drops below 50% of the other two phases.



# 2.1

## NEMA Contactors and Starters

### Freedom Series

#### Catalog Number Selection

2

#### Freedom Series NEMA Starters with C440 Electronic Overload Relays <sup>①</sup>

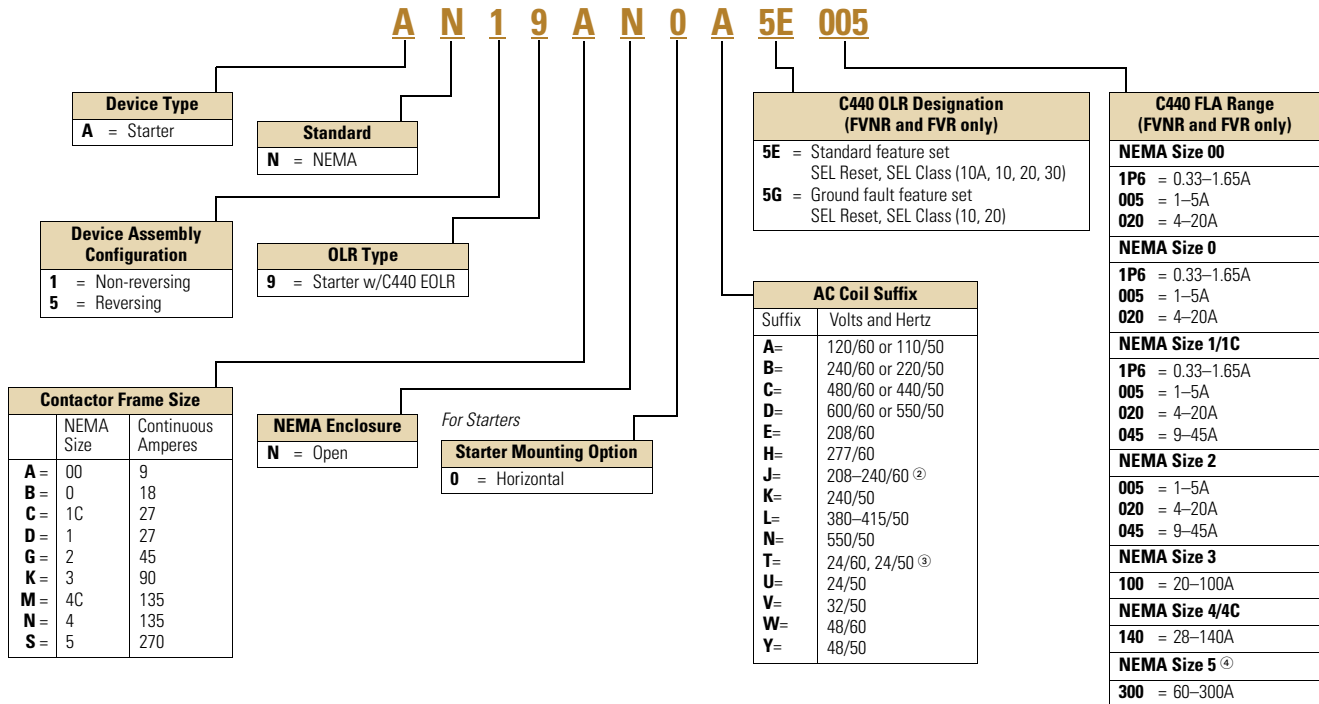

#### Notes

- ① See Page V5-T2-51 for Product Selection.
- ② NEMA Sizes 00 and 0 only.
- ③ NEMA Sizes 00 and 0 only. Sizes 1–3 are 24/60 only.
- ④ NEMA Size 5 starter available with 60–300A panel mounted CTs. Starter shipped as an assembled unit with 1–5A C440 overload relay (C440A1A005SELAX or C440A2A005SELAX).

### Product Selection

#### Type AN19/59 Freedom Series Starters

#### Type AN19/59 Freedom Series Starters with C440 Electronic Overload Relays

##### NEMA Starter



#### Non-Reversing and Reversing

NEMA Size	Continuous Ampere Rating	Service Limit Current Rating (Amps)	Maximum UL Horsepower						Three-Pole Non-Reversing <sup>①②</sup> Catalog Number	Three-Pole Reversing <sup>①②</sup> Catalog Number
			Single-Phase		Three-Phase		480V	600V		
			115V	230V	208V	240V				
00	9	11	1/3	1	1-1/2	1-1/2	2	2	AN19AN0_5E_	AN59AN0_5E_
0	18	21	1	2	3	3	5	5	AN19BN0_5E_	AN59BN0_5E_
1	27	32	2	3	7-1/2	7-1/2	10	10	AN19DN0_5E_	AN59DN0_5E_
2	45	52	3	7-1/2	10	15	25	25	AN19GN0_5E_	AN59GN0_5E_
3	90	104	—	—	25	30	50	50	AN19KN0_5E_	AN59KN0_5E_
4	135	156	—	—	40	50	100	100	AN19NN0_5E_	AN59NN0_5E_
5 <sup>③</sup>	270	311	—	—	75	100	200	200	AN19SN0_5E_	AN59SN0_5E_

#### Type AN19/59 Freedom Series Starters with C440 with Ground Fault Electronic Overload Relays

##### NEMA Starter with Ground Fault



#### Non-Reversing and Reversing

NEMA Size	Continuous Ampere Rating	Service Limit Current Rating (Amps)	Maximum UL Horsepower						Three-Pole Non-Reversing <sup>①②</sup> Catalog Number	Three-Pole Reversing <sup>①②</sup> Catalog Number
			Single-Phase		Three-Phase		480V	600V		
			115V	230V	208V	240V				
00	9	11	1/3	1	1-1/2	1-1/2	2	2	AN19AN0_5G_	AN59AN0_5G_
0	18	21	1	2	3	3	5	5	AN19BN0_5G_	AN59BN0_5G_
1	27	32	2	3	7-1/2	7-1/2	10	10	AN19DN0_5G_	AN59DN0_5G_
2	45	52	3	7-1/2	10	15	25	25	AN19GN0_5G_	AN59GN0_5G_
3	90	104	—	—	25	30	50	50	AN19KN0_5G_	AN59KN0_5G_
4	135	156	—	—	40	50	100	100	AN19NN0_5G_	AN59NN0_5G_
5 <sup>③</sup>	270	311	—	—	75	100	200	200	AN19SN0_5G_	AN59SN0_5G_

#### Coil Suffix Codes

Suffix	Coil Volts and Hertz	Suffix	Coil Volts and Hertz
A	120/60 or 110/50	L	380–415/50
B	240/60 or 220/50	N	550/50
C	480/60 or 440/50	T	24/60, 24/50
D	600/60 or 550/50	U	24/50
E	208/60	V	32/50
H	277/60	W	48/60
J	208–240/60	Y	48/50
K	240/50		

#### C440 FLA Range (FVNR and FVR Starters Only)

NEMA Size	OLR Code	FLA Range	OLR Code	FLA Rating
00	1P6	0.33–1.65A	020	4.0–20A
	005	1.0–5.0A	—	—
0	1P6	0.33–1.65A	020	4.0–20A
	005	1.0–5.0A	—	—
1	1P6	0.33–1.65A	020	4.0–20A
	005	1.0–5.0A	045	9.0–45A
2	005	1.0–5.0A	045	9.0–45A
	020	4.0–20A	—	—
3	100	20–100A	—	—
4	140	28–140A	—	—
5 <sup>③</sup>	300	60–300A	—	—

#### Notes

- ① Underscore ( \_ ) indicates coils suffix required, see Coil Suffix table above.
- ② Underscore ( \_ ) indicates OLR designation required, see C440 FLA Range table above.
- ③ NEMA Size 5 starter available with 60-300A panel mounted CTs. Starter shipped as an assembled unit with 1–5A C440 overload relay (C440A1A005SELAX or C440A2A005SELAX).

# 2.1

## NEMA Contactors and Starters

### Freedom Series

#### Compact NEMA Size 1 and 4 Starters

New Compact NEMA Size 1 and 4 starters—available with electronic overload relay **only**.

2

#### Non-Reversing

NEMA Size	Continuous Ampere Rating	Service Limit Current Rating (Amps)	Maximum UL Horsepower				480V	600V	Three-Pole Non-Reversing Catalog Number
			Single-Phase 115V	230V	208V	240V			
<b>Standard Fault Overload</b>									
1C	27	32	2	3	7.5	7.5	10	10	AN19CN0_5E_
4C	135	156	—	—	40	50	100	100	AN19MN0_5E_
<b>Ground Fault Overload</b>									
1C	27	32	2	3	7.5	7.5	10	10	AN19CN0_5G_
4C	135	156	—	—	40	50	100	100	AN19MN0_5G_

#### Electrical Life at Rated Continuous Current

NEMA Size	Rated Current (Amperage)		NEMA Size	Rated Current (Amperage)	
	AC3/AC4	Operations		AC3/AC4	Operations
1C	27/150	2,500,000/40,000	4C	135/516	500,000/40,000
1	27/153	5,000,000/110,000	4	135/822	800,000/70,000

#### AN19 Competitive Retrofit Kits

The retrofit kits provide a packaged solution to replace competitive starters with the Freedom AN19 starter using existing hole patterns. Suitable for replacement of Allen-Bradley, Square D, GE and Siemens starters.

#### Kit contents

- Competitive mounting plate
- AN19 starter
- Remote reset module
- NO 10250T pushbutton
- RESET pushbutton legend plate
- 16 gauge control wire



#### AN19 Competitive Retrofit Kit—Product Selection

Size	Description	Catalog Number
1	120 Vac coil, 4–20A overload	AN19DN0A5E020-CRK
2	120 Vac coil, 9–45A overload	AN19GN0A5E045-CRK
3	120 Vac coil, 20–100A overload	AN19KN0A5E100-CRK
4	120 Vac coil, 28–140A overload	AN19NN0A5E140-CRK
5	120 Vac coil, 60–300A overload	AN19SN0A5E300-CRK

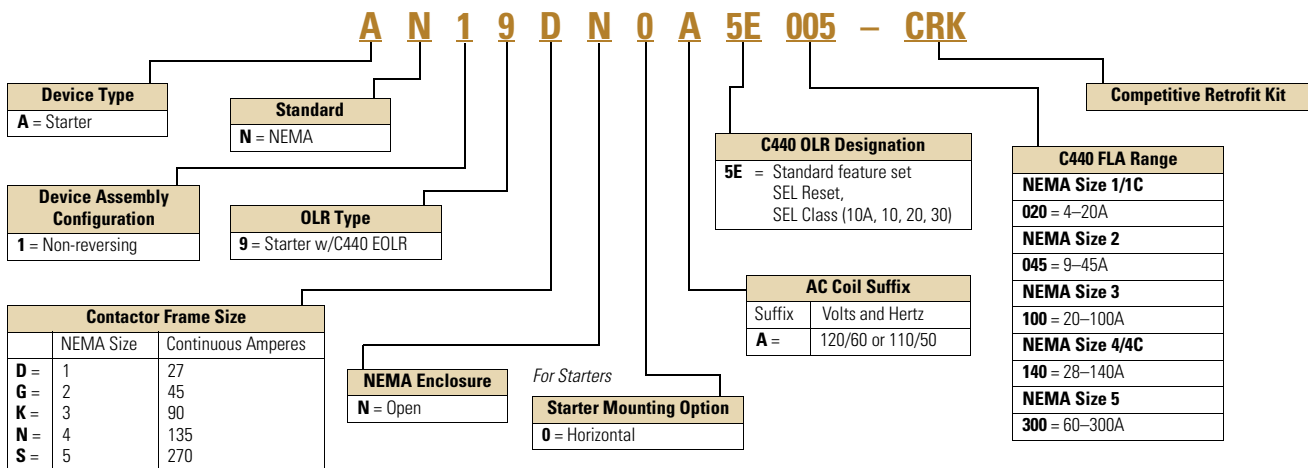

#### AN19 Competitive Retrofit Kit—Catalog Number Selection



**Accessories**

**CT Kits**

**Accessories**

	Description	Catalog Number
<p><b>Safety Cover</b></p> 	<p><b>Safety Cover</b></p> <p>Clear Lexan cover that mounts on top of the FLA dial and DIP switches when closed.</p>	<p><b>ZEB-XSC</b></p>
<p><b>Reset Bar</b></p> 	<p><b>Reset Bar</b></p> <p>Assembles to the top of the overload to provide a larger target area for door mounted reset operators.</p>	<p><b>ZEB-XRB</b></p>
<p><b>Remote Reset</b></p> 	<p><b>Remote Reset</b></p> <p>Remote reset module (24 Vdc) ①</p> <p>Remote reset module (120 Vac) ①</p> <p>Remote reset module (24 Vac) ①</p>	<p><b>C440-XCOM</b></p> <p><b>ZEB-XRR-120</b></p> <p><b>ZEB-XRR-24</b></p>

**Communication**

The C440/XTOE is provided with two levels of communication capability.

**Basic Communication via Expansion Module—Monitoring Only**

Basic communication on the C440 is accomplished using an expansion module (C440-XCOM). The expansion module plugs into the expansion bay on the C440 overload relay, enabling communications with the overload via their Modbus RTU (RS-485) network. No additional cards or modules are required. See figure below.



**Basic Communication—Modbus**

**Advanced Communication—Monitoring and Control**

C440 also has the ability to communicate on industrial protocols such as Modbus RTU, DeviceNet, PROFIBUS, Modbus TCP, and EtherNet/IP while providing control capability using I/O.

An expansion module (C440-XCOM) combined with a communication adapter (C440-COM-ADP) and a communication module allows easy integration onto the customer's network. See figure below. ②



**Advanced Communication—Communication Adapter with Communication Module**

**Advanced Communication—Communication Adapter ②**

The communication adapter (C440-COM-ADP) is required for obtaining control capability via communications within the C440 family. Combined with a communication module, the customer is provided with flexible mounting options (DIN rail or panel) along with four inputs and two outputs (24 Vdc or 120 Vac) as standard.

**Notes**

- ① Customer can wire remote mounted button to reset module (that is, 22 mm pushbutton, catalog number M22-D-B-GB14-K10).
- ② Modbus TCP and EtherNet/IP communication modules do not require the C440-COM-ADP communication adapter.

# 2.1

## NEMA Contactors and Starters



### Freedom Series

2

The following information can be viewed using the communication option:

- Motor status—running, stopped, tripped or resetting
- Individual rms phase currents (A, B, C)
- Average of three-phase rms current
- Percent thermal capacity
- Fault codes (only available prior to reset)
- Percent phase unbalance
- Ground fault current and percent
- Overload relay settings—trip class, DIP switch selections, reset selections
- Modbus address (can be set over the network)

#### Communication Accessories

	Description	Catalog Number
<b>Expansion Module</b>	Expansion module (Remote Reset/Modbus RTU, RS-485 Communication)	<b>C440-XCOM</b>
		
<b>Communication Adapter</b>	Communication adapter kit (DIN C Panel mounted adapter, required for advance communication option)	<b>C440-COM-ADP</b>
		
	DeviceNet communication module kit—120V I/O (consists of C440-XCOM + C441K + C440-COM-ADP)	<b>C440-DN-120</b>
	DeviceNet communication module kit—24 Vdc I/O (consists of C440-XCOM + C441L + C440-COM-ADP)	<b>C440-DN-24</b>
	PROFIBUS communication module kit—120V I/O (consists of C440-XCOM + C441S + C440-COM-ADP)	<b>C440-DP-120</b>
	PROFIBUS communication module kit—24V I/O (consists of C440-XCOM + C441Q + C440-COM-ADP)	<b>C440-DP-24</b>
	Modbus communication module kit—120V I/O (consists of C440-XCOM + C441N + C440-COM-ADP)	<b>C440-MOD-120</b>
	Modbus communication module kit—24 Vdc I/O (consists of C440-XCOM + C441P + C440-COM-ADP)	<b>C440-MOD-24</b>
	Modbus TCP/Ethernet IP communication module kit—120V I/O (consists of C440-XCOM + C441U)	<b>C440-ET-120</b>
	Modbus TCP/Ethernet IP communication module kit—24V I/O (consists of C440-XCOM + C441V)	<b>C440-ET-24</b>

**Modbus Communication Module**

The Modbus communication module combined with an expansion module and a communication adapter provides monitoring and control capability to the C440/XTOE electronic overload relay via Modbus RTU communications. These modules also provide convenient I/O with 24 Vdc or 120 Vac options.



**Modbus  
Communication Module**

**Features and Benefits**

- The Modbus communication module is capable of baud rates up to 115K
- The Modbus address and baud rate configuration can be easily changed using the HMI user interface
- Modbus address and baud rate are set via convenient DIP switches; LEDs are provided to display Modbus traffic
- Configuration with common Modbus configuration tools
- Terminals
  - Unique locking mechanism provides for easy removal of the terminal block with the field wiring installed
  - Each terminal is marked for ease of wiring and troubleshooting
- Selectable I/O assemblies
  - 4IN/2OUT
  - Signal types include 24 Vdc I/O and 120 Vac I/O
- Each I/O module is optically isolated between the field I/O and the network adapter to protect the I/O and communication circuits from possible damage due to transients and ground loops
- Input Module features a user-definable input debounce, which limits the effects of transients and electrical noise
- Output Module supports a user-definable safe state for loss of communication; hold last state, ON or OFF

**DeviceNet Communication Modules**

The DeviceNet communication module combined with an expansion module and a communication adapter provides monitoring and control capability to the C440/XTOE electronic overload relay via DeviceNet communications. These modules also provide convenient I/O with 24 Vdc or 120 Vac options.



**DeviceNet  
Communication Module**

**Features and Benefits**

- Communication to DeviceNet uses only one DeviceNet MAC ID
- Configuration
  - DeviceNet MAC ID and Baud rate are set via convenient DIP switches with an option to set from the network
  - Advanced configuration available using common DeviceNet tools
- Terminals
  - Unique locking mechanism provides for easy removal of the terminal block with the field wiring installed
  - Each terminal is marked for ease of wiring and troubleshooting
- Selectable I/O assemblies
  - 4IN/2OUT
  - Signal types include 24 Vdc I/O and 120 Vac I/O
- Each I/O module is optically isolated between the field I/O and the network adapter to protect the I/O and communication circuits from possible damage due to transients and ground loops
- Input Module features a user-definable input debounce, which limits the effects of transients and electrical noise
- Output Module supports a user-definable safe state for loss of communication; hold last state, ON or OFF
- Combined status LED

# 2.1

## NEMA Contactors and Starters

### Freedom Series

2

#### PROFIBUS Communication Modules

The PROFIBUS communication module combined with an expansion module and a communication adapter provides monitoring and control capability to the C440 / XTOE electronic overload relay via PROFIBUS communications. These modules also provide convenient I/O with 24 Vdc or 120 Vac options.



**PROFIBUS Communication Module**

#### Features and Benefits

- The PROFIBUS communication module is capable of baud rates up to 12 Mb
- PROFIBUS address is set via convenient DIP switches; LEDs are provided to display PROFIBUS status
- Intuitive configuration with common PROFIBUS configuration tools
- Terminals
  - Unique locking mechanism provides for easy removal of the terminal block with the field wiring installed
  - Each terminal is marked for ease of wiring and troubleshooting
- Selectable I/O assemblies
  - 4IN/2OUT
  - Signal types include 24 Vdc I/O and 120 Vac I/O
- Each I/O module is optically isolated between the field I/O and the network adapter to protect the I/O and communication circuits from possible damage due to transients and ground loops
- Input Module features a user-definable input debounce, which limits the effects of transients and electrical noise
- Output Module supports a user-definable safe state for loss of communication; hold last state, ON or OFF

#### Ethernet Communication Modules

The Ethernet communication module combined with an expansion module provides both Modbus TCP and EtherNet/IP communication capabilities with built-in HTTP web services to the C440/XTOE overload relay. Unlike the other communications modules, a communication adapter (C440-COM-ADP) is not required when using the Ethernet communication module in C440/XTOE applications.

The Ethernet communication module has built-in I/O providing communication, monitoring and control for the C440/XTOE overload relay.

#### Features and Benefits

- Supports Modbus TCP or EtherNet/IP in a single device
- Contains an internal embedded switch which provides two Ethernet ports allowing linear or ring network configurations
- Embedded web services allow for simple configuration and monitoring through Internet Explorer
- IP Address is set via convenient DIP Switches located on the device
- Terminals
  - Unique locking mechanism provides for easy removal of the terminal block with the field wiring installed
  - Each terminal is marked for ease of wiring and troubleshooting
- Selectable I/O assemblies
  - 4IN/2OUT
  - Signal types include 24 Vdc I/O and 120 Vac I/O
- Each I/O module is optically isolated between the field I/O and the network adapter to protect the I/O and communication circuits from possible damage due to transients and ground loops
- Input Module features a user-definable input debounce, which limits the effects of transients and electrical noise
- Output Module supports a user-definable safe state for loss of communication; hold last state, ON or OFF

#### Ethernet with I/O Module



#### Ethernet Communication Module

Description	I/O	Catalog Number
Modbus TCP / EtherNet/IP Communication Module, 4IN/2OUT (DIN/Panel)	120 Vac	<b>C441U</b>
Modbus TCP / EtherNet/IP Communication Module, 4IN/2OUT (DIN/Panel)	24 Vdc	<b>C441V</b>

## Technical Data and Specifications

### Electronic Overload Relays up to 1500A

Description	Specification		
	45 mm	55 mm	110 mm
<b>Electrical Ratings</b>	<b>Range</b>	<b>Range</b>	<b>Range</b>
Operating voltage (three-phase) and frequency	690 Vac (60/50 Hz)	690 Vac (60/50 Hz)	690 Vac (60/50 Hz)
<b>FLA Range</b>			
	0.33–1.65A 1–5A 4–20A 9–45A	20–100A	28–140A (NEMA) 35–175A (IEC)
<b>Use with Contactors</b>			
<b>X7</b> IEC frames	B, C, D	F, G	G, H
Freedom NEMA sizes	00, 0, 1, 2	3	4
<b>Trip Class</b>			
	10A, 10, 20, 30 Selectable	10A, 10, 20, 30 Selectable	10A, 10, 20, 30 Selectable
<b>Motor Protection</b>			
Thermal overload setting	1.05 x FLA: does not trip 1.15 x FLA: overload trip	1.05 x FLA: does not trip 1.15 x FLA: overload trip	1.05 x FLA: does not trip 1.15 x FLA: overload trip
<b>Feature</b>	<b>Range</b>	<b>Range</b>	<b>Range</b>
Phase loss	Fixed threshold 50%	Fixed threshold 50%	Fixed threshold 50%
Phase unbalance (selectable: enable/disable)	Fixed threshold 50%	Fixed threshold 50%	Fixed threshold 50%
Ground fault (selectable: enable/disable)	50% of FLA dial setting >150% = 2 sec >250% = 1 sec	50% of FLA dial setting >150% = 2 sec >250% = 1 sec	50% of FLA dial setting >150% = 2 sec >250% = 1 sec
Reset	Manual/automatic	Manual/automatic	Manual/automatic
<b>Indicators</b>			
Trip status	Orange flag	Orange flag	Orange flag
Mode LED	One flash: Overload operating properly Two flashes: Current is above FLA dial setting—pending trip	One flash: Overload operating properly Two flashes: Current is above FLA dial setting—pending trip	One flash: Overload operating properly Two flashes: Current is above FLA dial setting—pending trip
<b>Options</b>			
Remote reset	Yes	Yes	Yes
Reset bar	Yes	Yes	Yes
Communication expansion module	Yes	Yes	Yes
Communication adapter	Yes	Yes	Yes
<b>Capacity</b>			
Load terminals			
Terminal capacity	12–10 AWG (4–6 mm <sup>2</sup> ) 8–6 AWG (6–16 mm <sup>2</sup> )	6–1 AWG (16–50 mm <sup>2</sup> )	8–4/0 AWG (10–95 mm <sup>2</sup> )
Tightening torque	20–25 lb-in (2.3–2.8 Nm) 25–30 lb-in (2.8–3.4 Nm)	25–30 lb-in (2.8–3.4 Nm)	124 lb-in (14 Nm)
Input, auxiliary contact and remote reset terminals			
Terminal capacity	2 x (18–12) AWG	2 x (18–12) AWG	2 x (18–12) AWG
Tightening torque	7–11 lb-in (0.8–1.2 Nm)	7–11 lb-in (0.8–1.2 Nm)	7–11 lb-in (0.8–1.2 Nm)
<b>Voltages</b>			
Insulation voltage U <sub>i</sub> (three-phase)	690 Vac	690 Vac	690 Vac
Insulation voltage U <sub>i</sub> (control)	500 Vac	500 Vac	500 Vac
Rated impulse withstand voltage	6000 Vac	6000 Vac	6000 Vac
Overvoltage category/pollution degree	III/3	III/3	III/3



# 2.1

## NEMA Contactors and Starters

### Freedom Series

#### Electronic Overload Relays up to 1500A, continued

2

Description	Specification		
	45 mm	55 mm	110 mm
<b>Auxiliary and Control Circuit Ratings</b>			
Conventional thermal continuous current	5A	5A	5A
Rated operational current—IEC AC-15			
Make contact (1800 VA)			
120V	15A	15A	15A
240V	15A	15A	15A
415V	0.5A	0.5A	0.5A
500V	0.5A	0.5A	0.5A
Break contact (180 VA)			
120V	1.5A	1.5A	1.5A
240V	1.5A	1.5A	1.5A
415V	0.9A	0.9A	0.9A
500V	0.8A	0.8A	0.8A
IEC DC-13 (L/R F 15 ms1)			
0–250V	1.0A	1.0A	1.0A
Rated operational current—UL B600			
Make contact (3600 VA)			
120V	30A	30A	30A
240V	15A	15A	15A
480V	7.5A	7.5A	7.5A
600V	6A	6A	6A
Break contact (360 VA)			
120V	3A	3A	3A
240V	1.5A	1.5A	1.5A
480V	0.75A	0.75A	0.75A
600V	0.6A	0.6A	0.6A
R300—Vdc ratings (28 VA)			
0–120V	0.22A	0.22A	0.22A
250V	0.11A	0.11A	0.11A
<b>Short-Circuit Rating without Welding</b>			
Maximum fuse	6A gG/gL	6A gG/gL	6A gG/gL
<b>Environmental Ratings</b>			
Ambient temperature (operating)	–13° to 149°F (–25° to 65°C)	–13° to 149°F (–25° to 65°C)	–13° to 149°F (–25° to 65°C)
Ambient temperature (storage)	–40° to 185°F (–40° to 85°C)	–40° to 185°F (–40° to 85°C)	–40° to 185°F (–40° to 85°C)
Operating humidity UL 991 (H3)	5% to 95% non-condensing	5% to 95% non-condensing	5% to 95% non-condensing
Altitude (no derating) NEMA ICS1	2000m	2000m	2000m
Shock (IEC 600068-2-27)	15g any direction	15g any direction	15g any direction
Vibration (IEC 60068-2-6)	3g any direction	3g any direction	3g any direction
Pollution degree per IEC 60947-4-1	3 for product (2 for pcb)	3 for product (2 for pcb)	3 for product (2 for pcb)
Ingress protection	IP20	IP20	IP20
Protection against direct contact when actuated from front (IEC 536)	Finger- and back-of-hand proof	Finger- and back-of-hand proof	Finger- and back-of-hand proof
Mounting position	Any	Any	Any
Climatic proofing	Damp heat, constant to IEC 60068-2-30	Damp heat, constant to IEC 60068-2-30	Damp heat, constant to IEC 60068-2-30

## Electronic Overload Relays up to 1500A, continued

Description	Specification		
	45 mm	55 mm	110 mm
<b>Electrical/EMC</b>			
Radiated emissions IEC 60947-4-1-Table 15 EN 55011 (CISPIR 11) Group 1, Class A, ISM	30 mHz to 1000 mHz	30 mHz to 1000 mHz	30 mHz to 1000 mHz
Conducted emissions IEC 60947-4-1-Table 14 EN 55011 (CISPIR 11) Group 1; Class ISM	0.15 mHz to 30 mHz	0.15 mHz to 30 mHz	0.15 mHz to 30 mHz
ESD immunity IEC 60947-4-1 (Table 13)	±8 kV air, ±6 kV contact	±8 kV air, ±6 kV contact	±8 kV air, ±6 kV contact
Radiated immunity IEC 60947-4-1 IEC 61000-4-3	10 V/m 80 mHz–1000 mHz 3 V/m from 1.4 to 2.7 GHz 80% amplitude modulated 1 kHz sine wave	10 V/m 80 mHz–1000 mHz 3 V/m from 1.4 to 2.7 GHz 80% amplitude modulated 1 kHz sine wave	10 V/m 80 mHz–1000 mHz 3 V/m from 1.4 to 2.7 GHz 80% amplitude modulated 1 kHz sine wave
Conducted immunity IEC 60947-4-1, IEC 61000-4-6	140 dub (10V rms) 150 kHz–100 mHz	140 dub (10V rms) 150 kHz–100 mHz	140 dub (10V rms) 150 kHz–100 mHz
Fast transient immunity IEC 60947-4-1 (Table 13) IEC 61000-4-4	±4 kV using direct method with accessory installed in expansion bay ±2 kV using direct method	±4 kV using direct method with accessory installed in expansion bay ±2 kV using direct method	±4 kV using direct method with accessory installed in expansion bay ±2 kV using direct method
Surge immunity IEC 60947-4-1 (Table 13) IEC 61000-4-5 a Class 4	Three-phase power inputs: ±4 kV line-to-line (DM) ±4 kV line-to-ground (CM)  With accessory installed in expansion bay: ±2 kV line-to-line (DM) →1.2/50 us; 2 kV line-to-earth, 1 kV line-to-line ±4 kV line-to-ground (CM)	Three-phase power inputs: ±4 kV line-to-line (DM) ±4 kV line-to-ground (CM)  With accessory installed in expansion bay: ±2 kV line-to-line (DM) →1.2/50 us; 2 kV line-to-earth, 1 kV line-to-line ±4 kV line-to-ground (CM)	Three-phase power inputs: ±4 kV line-to-line (DM) ±4 kV line-to-ground (CM)  With accessory installed in expansion bay: ±2 kV line-to-line (DM) →1.2/50 us; 2 kV line-to-earth, 1 kV line-to-line ±4 kV line-to-ground (CM)
Power freq. magnetic field immunity IEC 60947-4-1, IEC 61000-4-8	30 A/m, 50 Hz	30 A/m, 50 Hz	30 A/m, 50 Hz
Electromagnetic field IEC 60947-4-1 Table 13, IEC 61000-4-3	10 V/m	10 V/m	10 V/m
Distortion IEEE 519	5% THD max., 5th harmonic 3% max.	5% THD max., 5th harmonic 3% max.	5% THD max., 5th harmonic 3% max.
Electrostatic discharge (ESD) IEC 61000-4-2, EN 61131-2	4 kV contact 8 kV air discharge	4 kV contact 8 kV air discharge	4 kV contact 8 kV air discharge
Electrical fast transient (EFT) IEC 61000-4-4, EN 61131-2	±2 kV using direct method	±2 kV using direct method	±2 kV using direct method
Surge immunity IEC 61000-4-5, EN 61131-2	±2 kV line-to-ground (CM)	±2 kV line-to-ground (CM)	±2 kV line-to-ground (CM)

## Communication Modules

2

Description	Modbus	DeviceNet	PROFIBUS	Ethernet
<b>Electrical/EMC</b>				
Radiated emissions IEC 60947-4-1—Table 15, EN 55011 (CISPR 11) Group 1, Class A	30–1000 mHz	30–1000 mHz	30–1000 mHz	30–1000 mHz
Conducted emissions IEC 60947-4-1—Table 14, EN 55011 (CISPR 11) Group 1, Class A	0.15–30 mHz	0.15–30 mHz	0.15–30 mHz	0.15–30 mHz
ESD immunity IEC 60947-4-1 (Table 13)	±8 kV air, ±4 kV contact	±8 kV air, ±4 kV contact	±8 kV air, ±4 kV contact	±8 kV air, ±4 kV contact
Radiated immunity IEC 60947-4-1	10 V/m 80–1000 mHz 80% amplitude modulated 1 kHz sine wave	10 V/m 80–1000 mHz 80% amplitude modulated 1 kHz sine wave	10 V/m 80–1000 mHz 80% amplitude modulated 1 kHz sine wave	10 V/m 80–1000 mHz 80% amplitude modulated 1 kHz sine wave
Conducted immunity IEC 60947-4-1	140 dBuV (10V rms) 150 kHz–80 mHz	140 dBuV (10V rms) 150 kHz–80 mHz	140 dBuV (10V rms) 150 kHz–80 mHz	140 dBuV (10V rms) 150 kHz–80 mHz
Fast transient immunity IEC 60947-4-1 (Table 13) IEC 6100-4-4	±2 kV using direct method	±2 kV supply and control, ±1 kV communication	±2 kV supply and control, ±1 kV communication	±2 kV supply and control, ±1 kV communication
Surge immunity IEC 60947-4-1 (Table 13) IEC 61000-4-5 Class 3	User IO and communication lines <sup>①</sup> : ±1 kV line-to-line (DM) ±2 kV line-to-ground (CM)	User IO and communication lines: ±0.5 kV line-to-line (DM) ±1 kV line-to-ground (CM)	User IO and communication lines: ±0.5 kV line-to-line (DM) ±1 kV line-to-ground (CM)	User IO and communication lines: ±0.5 kV line-to-line (DM) ±1 kV line-to-ground (CM)
Electromagnetic field <sup>①</sup> IEC 60947-4-1 (Table 13) IEC 61000-4-3	10 V/m	10 V/m	10 V/m	10 V/m
<b>Environmental Ratings</b>				
Ambient temperature (operating)	–4° to 122°F (–20° to 50°C)	–13° to 122°F (–25° to 50°C)	–13° to 122°F (–25° to 50°C)	–13° to 122°F (–25° to 50°C)
Ambient temperature (storage)	–40° to 185°F (–40° to 85°C)	–40° to 185°F (–40° to 85°C)	–40° to 185°F (–40° to 85°C)	–40° to 185°F (–40° to 85°C)
Operating humidity	5–95% noncondensing	5–95% noncondensing	5–95% noncondensing	5–95% noncondensing
Altitude (no derating)	2000m	2000m	2000m	2000m
Shock (IEC 60068-2-27)	15G any direction	15G any direction	15G any direction	15G any direction
Vibration (IEC 60068-2-6)	3G any direction	3G any direction	3G any direction	3G any direction
Pollution degree per IEC 60947-1	3	3	3	3
Degree of protection	IP20	IP20	IP20	IP20
Overvoltage category per UL 508	III	III	III	III
<b>DeviceNet</b>				
DeviceNet connections	—	Group 2, polling, bit strobe, explicit, no UCMM	—	—
DeviceNet baud rate	—	125K, 250K, 500K	—	—
<b>Ethernet</b>				
Ethernet connections	—	—	—	Integrated two-port switch with dual RJ45 Ethernet connections
Ethernet type	—	—	—	Ethernet 10/100 Mbs, AutoMDX, Auto Negotiation
<b>PROFIBUS</b>				
PROFIBUS connections	—	—	Group 2, polling, bit strobe, explicit, no UCMM	—
PROFIBUS baud rate	—	—	9.6K, 19.2K, 45.45K, 93.75K, 187.5K, 500K, 1.5M, 3M, 6M, 12M	—

**Note**

<sup>①</sup> Relates to C441M only.

## Communication Modules, continued

Description	Modbus	DeviceNet	PROFIBUS	Ethernet
<b>C441_ 24 Vdc Input</b>				
Nominal input voltage	24 Vdc	24 Vdc	24 Vdc	24 Vdc
Operating voltage	18–30 Vdc	18–30 Vdc	18–30 Vdc	18–30 Vdc
Number of inputs	4	4	4	4
Signal delay	5 ms (programmable to 65 sec)	5 ms (programmable to 65 sec)	5 ms (programmable to 65 sec)	5 ms (programmable to 65 sec)
OFF-state voltage	<6 Vdc	<6 Vdc	<6 Vdc	<6 Vdc
ON-state voltage	>18 Vdc	>18 Vdc	>10 Vdc	>18 Vdc
Nominal input current	5 mA	5 mA	5 mA	5 mA
Isolation	1500V	1500V	1500V	1500V
Terminal screw torque	7–9 in-lb	7–9 in-lb	7–9 in-lb	7–9 in-lb
24V source current	50 mA	50 mA	50 mA	50 mA
<b>Operating Voltage Range—DC Input Modules</b>				
OFF state	0–6 Vdc	0–6 Vdc	0–6 Vdc	0–6 Vdc
Transition region	6–18 Vdc	6–18 Vdc	6–18 Vdc	6–18 Vdc
ON state	18–30 Vdc	18–30 Vdc	18–30 Vdc	18–30 Vdc
<b>C441_ 120 Vac Input</b>				
Nominal input voltage	120 Vac	120 Vac	120 Vac	120 Vac
Operating voltage	80–140 Vac	80–140 Vac	80–140 Vac	80–140 Vac
Number of inputs	4	4	4	4
OFF-state voltage	<30 Vac	<30 Vac	<20 Vac	<30 Vac
ON-state voltage	>80 Vac	>80 Vac	>70 Vac	>80 Vac
Nominal input current	15 mA	15 mA	15 mA	15 mA
Signal delay	1/2 cycle	1/2 cycle	1/2 cycle	1/2 cycle
Isolation	1500V	1500V	1500V	1500V
Terminal screw torque	7–9 in-lb	7–9 in-lb	7–9 in-lb	7–9 in-lb
<b>Operating Voltage Range—AC Input Modules</b>				
OFF state	0–30 Vac	0–30 Vac	0–30 Vac	0–30 Vac
Transition region	30–80 Vac	30–80 Vac	30–80 Vac	30–80 Vac
ON state	80–140 Vac	80–140 Vac	80–140 Vac	80–140 Vac
<b>Output Modules</b>				
Nominal voltage	120 Vac 24 Vdc	120 Vac 24 Vdc	120 Vac 24 Vdc	120 Vac 24 Vdc
Number of outputs	(2) 1NO Form A 1NO/NC Form C	(2) 1NO Form A 1NO/NC Form C	(2) 1NO Form A 1NO/NC Form C	(2) 1NO Form A 1NO/NC Form C
Relay OFF time	3 ms	3 ms	3 ms	3 ms
Relay ON time	7 ms	7 ms	7 ms	7 ms
Max. current per point <sup>①</sup>	5A (B300 rated)	5A (B300 rated)	5A (B300 rated)	5A (B300 rated)
Electrical life	100,000 cycles	100,000 cycles	100,000 cycles	100,000 cycles
Mechanical life	1,000,000 cycles	1,000,000 cycles	1,000,000 cycles	1,000,000 cycles

**Note**

<sup>①</sup> Relates to C441M only.

# 2.1

## NEMA Contactors and Starters

### Freedom Series

2

#### Short Circuit Ratings (North America CSA, cUL)

Changes to UL 508A and NEC in recent years have brought a focus to control panel safety with regard to short-circuit current ratings (SCCR). Eaton's C440 electronic overload relays combined with **XT** series IEC and Freedom Series NEMA contactors provide a wide variety of SCCR solutions needed for a variety of applications. The SCCR data in this document reflects the latest information as of April 2010.

#### C440/XT Standalone Overload Relays (XT, C440)

Overload FLA Range	Maximum Operating Voltage	Standard-Fault Short Circuit Data			High-Fault Short Circuit Data Fuses (RK5, J, CC)			Thermal-Magnetic Circuit Breakers		
		600V (kA)	Maximum Fuse Size (A) (RK5)	Maximum Breaker Size (A)	480V (kA)	600V (kA)	Maximum Fuse Size	480V (kA)	600V (kA)	Maximum Breaker Size
0.33–1.65A	600 Vac	1	6	15	—	—	—	—	—	—
1–5A	600 Vac	5	20	20	100	100	30	100	35	20
4–20A	600 Vac	5	80	80	100	100	100	100	35	80
9–45A	600 Vac	5	175	175	100	100	100	100	35	100/175 (480/600)
20–100A	600 Vac	10	400	400	100	100	200	150	35	250/400 (480/600)
28–140A	600 Vac	10	450	500	100	100	400	100	65	400
35–175A	690 Vac	10	500 (gG)	350 (690 Vac) 320 (415 Vac)	100	100	500 (gG)	100 (415 Vac)	—	350 (LGC3350) 320 (N2MH3)

#### NEMA Freedom Series Starters with C440 Electronic Overload Relays

NEMA Size	Maximum Operating Voltage	High-Fault Short Circuit Data Fuses (RK5, J, CC)			Thermal-Magnetic Circuit Breakers		
		480V	600V	Maximum Fuse Size	480V	600V	Maximum Breaker Size
00	0.33–1.65A	100	100	30	—	—	—
	1–5A	100	100	30	100	35	35
	4–20A	100	100	30	100	35	35
0	0.33–1.65A	100	100	60	—	—	—
	1–5A	100	100	60	100	35	70
	4–20A	100	100	60	100	35	70
1	0.33–1.65A	100	100	100	—	—	—
	1–5A	100	100	100	100	35	100
	4–20A	100	100	100	100	35	100
	9–45A	100	100	100	100	35	100
2	1–5A	100	100	100	100	35	175
	4–20A	100	100	100	100	35	175
	9–45A	100	100	100	100	35	175
3	20–100A	100	100	200	50	50	250
4	28–140A	100	100	400	100	65	300

### Dimensions

Approximate Dimensions in Inches (mm)

#### NEMA Starters

#### Full Voltage Non-Reversing Starters

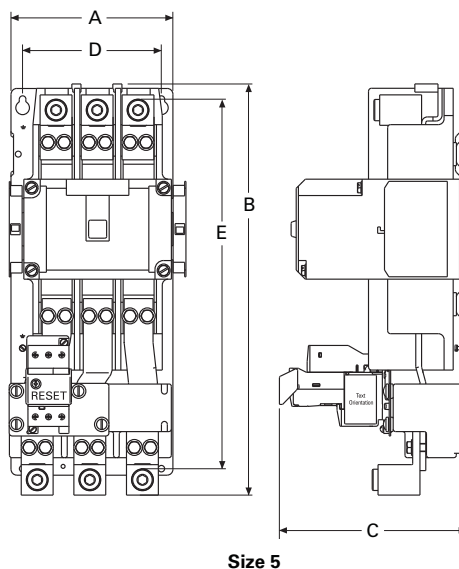
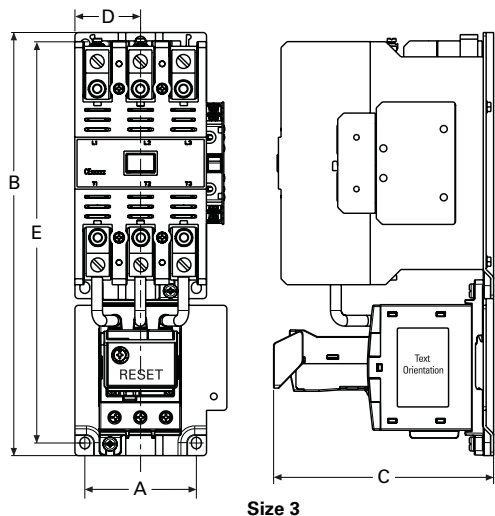
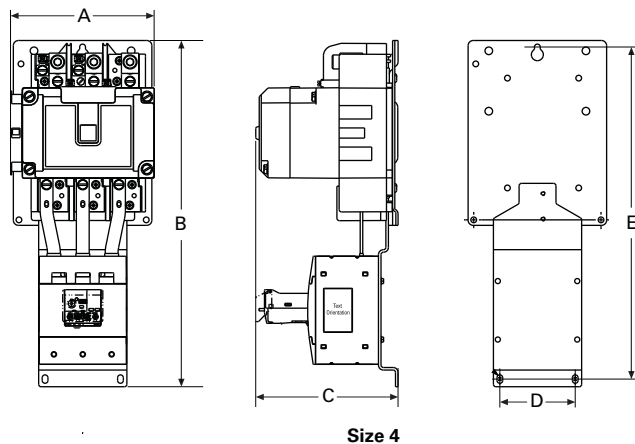
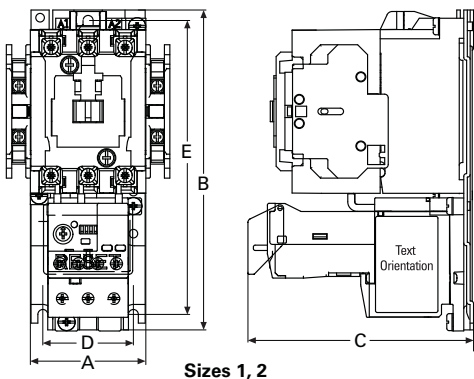
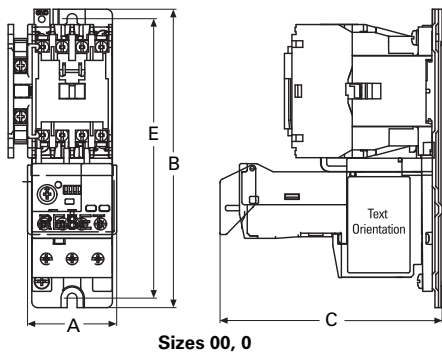

NEMA Size	A	B	C	D	E
00, 0	1.97 (50.0)	6.60 (167.6)	4.90 (124.5)	—	6.18 (157.0)
1, 2	2.60 (65.0)	7.10 (180.0)	4.98 (126.5)	2.00 (50.8)	6.50 (165.0)
3	4.09 (103.8)	11.40 (289.6)	5.92 (150.3)	1.77 (44.9)	10.81 (274.6)
4	7.10 (179.0)	17.00 (432.0)	7.00 (177.0)	3.70 (94.0)	16.30 (415.0)
5	7.00 (177.8)	17.81 (452.3)	8.08 (205.2)	6.00 (152.4)	16.01 (406.6)

# 2.1

## NEMA Contactors and Starters

### Freedom Series

Approximate Dimensions in Inches (mm)

2

#### Full Voltage Reversing Starters

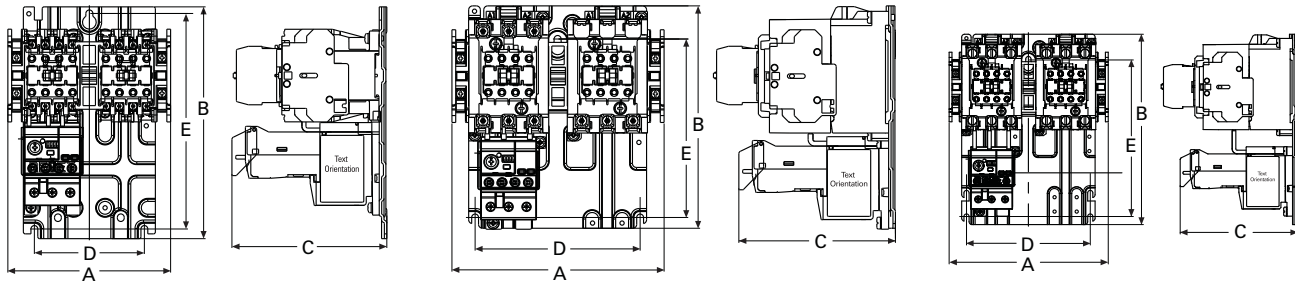

Sizes 00, 0

Size 1

Size 2

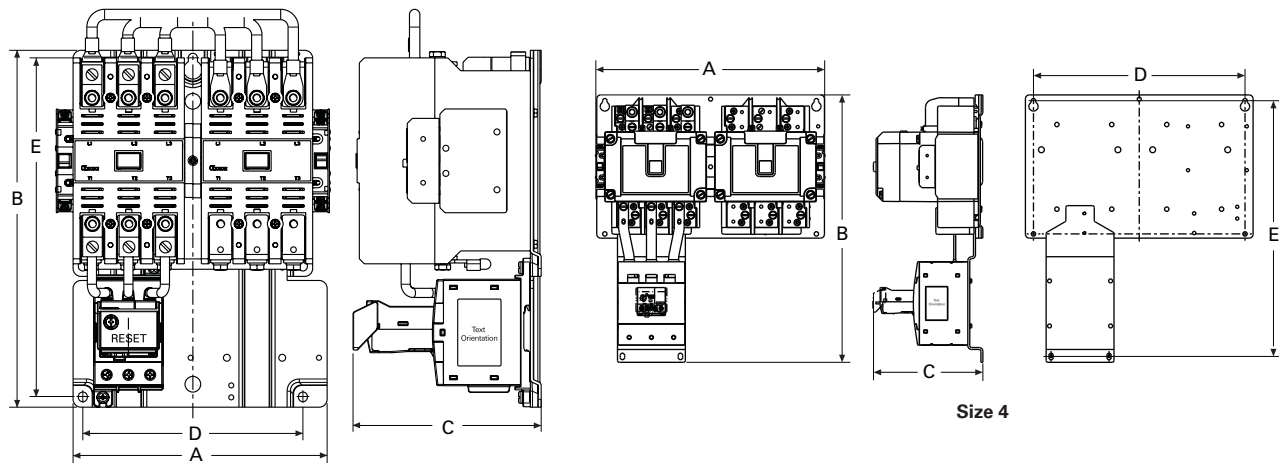

Size 3

Size 4

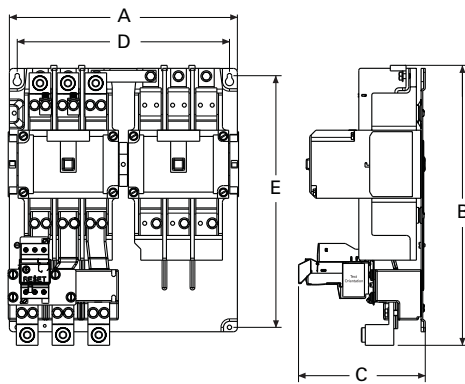

Size 5

NEMA Size	A	B	C	D	E
00, 0	5.20 (132.0)	7.40 (187.0)	4.90 (125.0)	3.50 (89.0)	6.90 (174.0)
1	6.70 (171.0)	7.10 (180.0)	4.98 (126.5)	5.25 (133.0)	5.70 (144.0)
2	6.70 (171.0)	8.10 (205.0)	4.98 (126.5)	5.25 (133.0)	6.70 (170.0)
3	8.08 (205.2)	11.35 (288.3)	6.00 (152.0)	7.00 (177.8)	10.77 (273.6)
4	14.60 (371.0)	17.10 (433.0)	7.00 (177.0)	13.50 (343.0)	16.30 (415.0)
5	14.50 (368.3)	17.81 (452.3)	8.06 (204.8)	13.50 (342.9)	16.00 (406.6)

## X-ON Electronics

Largest Supplier of Electrical and Electronic Components

*Click to view similar products for [eaton](#) manufacturer:*

Other Similar products are found below :

[BK-MDL-3-R](#) [BK1-S506-500-R](#) [BK1-S506-6-3-R](#) [BK1-S506-2-R](#) [MPI4040R4-1R5-R](#) [TDC600-10A](#) [89096-015](#) [8946K153](#) [8961K155](#)  
[M22-DL-W-X0](#) [M22-D-R-GB0/K11](#) [M22-L-R/R](#) [M22S-ST-GB12](#) [630NHG3B](#) [63ET](#) [6422](#) [6580](#) [CTX20-16-52LP-R](#) [CWL530FI](#)  
[CXM/CO/GP/R/BB](#) [6HD36](#) [714125](#) [MBO-2](#) [ESR5-NO-41-24VAC-DC](#) [7314K36](#) [7321K2](#) [F02A-1-1/2A](#) [F02A-1-1/2AS](#) [F02A-1AS](#) [F02A-2AS](#) [F02A-3/4A](#) [F03A250V12A](#) [F03B125V4A](#) [MCR-4](#) [MDA-2-8/10-R](#) [MDA-30A](#) [MDA-V-1/16](#) [F60C500V10AS](#) [F60C500V15AS](#)  
[7563K84](#) [7634K36](#) [MDQ-3/16](#) [MDQ-7/10](#) [MDQ-V-1/10](#) [MDQ-V-1-1/4](#) [MDQ-V-1/16](#) [MDQ-V-1/2](#) [MDQ-V-1/4](#) [MDQ-V-3/16](#) [MDQ-V-3/8](#)