

DENSITRON® DISPLAYS	MODEL NO.		PAGE
	DET070WVNTCMI-1W	SPEC ONLY	1

LIQUID CRYSTAL DISPLAY MODULE

Product Specification

CUSTOMER	Standard
CUSTOMER PART NUMBER	
PRODUCT NUMBER	DET070WVNTCMI-1W

Product Mgr	Design Eng
Bruno Recaldini	Luo Luo
Date: 07-March-13	Date: 07-March-13

Approval for Specification only

Approval for Specification and Sample

DENSITRON® DISPLAYS	MODEL NO.		PAGE
	DET070WVNTCMI-1W	SPEC ONLY	2

1. Table of Contents

No.	Contents	Page
1	Table of Contents	2
2	Record of Revisions	3
3	Module Numbering System	4
4	Application	5
5	Features	5
6	General Specifications	5
7	Absolute Maximum Ratings	6
8	Electrical Characteristics	7
9	Block Diagram	9
10	Input / Output Terminals Pin Assignment	10
11	Interface Timing	14
12	Optical Characteristics	22
13	Reliability Test	25
14	Packaging	26
15	Precautions	27
16	Outline Drawing	28
17	Incoming Inspection Standards	29

DENSITRON [®] DISPLAYS	MODEL NO.		PAGE
	DET070WVNTCMI-1W	SPEC ONLY	4

3. Module Numbering System

1	2	3	4	5	6	7	8	9	10	11	12	13	14	15	16
D	E	T	0	7	0	W	V	N	T	C	M	I	-	1	W

1	D	
2	E	DENSITRON Standard TFT
3	T	
4~6	0	TFT Size: 043 =4.3", 057 =5.7", 070 =7", 101 =10.1"
	7	
	0	
7~8	W	TFT Resolution: QQ : 480X272 (Quarter VGA), VG : 640X480 (VGA) WV : 800X480 (WVGA), WS : 1024X600 (WSVGA)
	V	
9	N	TFT Brightness: N : Normal Brightness, H : High Brightness
10	T	TFT Interface System: T : TTL, L : LVDS
11~13	C	Touch Type: NT : Non-Touch, CS : Capacitive Single Touch, CM : Capacitive Multi Touch, RS : Resistive Single Touch, RM : Resistive Multi Touch
	M	
	I	
14	-	
15~16	1	Revision
	W	A: Standard, W: Wide Viewing Angle

	MODEL NO.		PAGE
	DET070WVNTCMI-1W	SPEC ONLY	5

4. Application

This specification is applied to the 7 inch WVGA supported TFT-LCD module With projected capacitive touch (PCT) and can display true 262,144 colors(6 bit/ color). The module is designed for OA, Car TV application and other electronic products which require flat panel display of digital signal interface. This module is composed of a 7”TFT-LCD panel, a driver circuit and backlight unit.

5. Features

- WVGA (800×480 pixels) resolution.
- Digital 18 bit parallel RGB.
- Dot inversion mode with stripe type.
- Ultra Wide View Polarizer
- Projected Capacitive Touch
 - I²C Interface
 - Multi Touch (Ten points)

6. General Specifications

Item	Specifications	Unit
Screen Size	7 (Diagonal)	inch
Display Format	800RGB(H)×480(V)	dot
Active Area	152.4(H)×91.44(V)	mm
Dot Size	0.0635(H)×0.1905(V)	mm
Pixel Configuration	RGB Vertical Stripe	-
Display Mode	TN Type Transmissive Mode Normally White	-
Surface Treatment	Clear(7H)	-
Viewing Direction	6 O'clock (The Gray Inversion will appear at this direction)	-
Outline Dimension	166.6(W)×109.4(H)×11.15(D)	mm
Weight	(228)	g
RoHS Compliance	DENSITRON certifies this product to be in compliance with European Union Directive 2002/95/EC on the restriction of certain hazardous substances in electrical and electronic equipment.	-

DENSITRON® DISPLAYS	MODEL NO.		PAGE
	DET070WVNTCMI-1W	SPEC ONLY	6

7. Absolute Maximum Ratings

7.1 Absolute Ratings of Environment

Item	Symbol	Value		Unit	Note
		Min.	Max.		
Storage Temperature	T _{ST}	-30	+80	°C	(1)(2)
Operating Temperature	T _{OP}	-20	+70	°C	(1)(2)

Note1: Background color changes slightly depending on ambient temperature.

This phenomenon is reversible.

Note2: Please refer to item of RELIABILITY.

7.2 Electrical Absolute Ratings

7.2.1 TFT-LCD Module

(Ta=25±2°C, GND=V_{SS}=0V)

Item	Symbol	Value		Unit	Note
		Min.	Max.		
Digital Power Supply Voltage	V _{CC}	-0.3	4.3	V	-

7.2.2 Backlight Unit

(Ta=25±2°C)

Item	Symbol	Value		Unit	Note
		Min.	Max.		
Current of Backlight Unit	I _B	-	325	mA	(1)
Voltage of Backlight Unit	V _B	-	15	V	(1)

Note (1) Permanent damage to the device may occur if maximum values are exceeded or reverse voltage is loaded.

DENSITRON® DISPLAYS	MODEL NO.		PAGE
	DET070WVNTCMI-1W	SPEC ONLY	7

8. Electrical Characteristics

8.1 TFT-LCD Module

(Ta=25±2°C)

Item	Symbol	Value			Unit	Note
		Min.	Typ.	Max.		
Power Supply Voltage	V _{CC}	3.0	3.3	3.6	V	-
Power Supply Current	I _{CC}	-	190	266	mA	(1)
Input High Threshold Voltage	V _{IH}	0.7V _{CC}	-	V _{CC}	V	-
Input Low Threshold Voltage	V _{IL}	0	-	0.3V _{CC}	V	-
Power Consumption	P _L	-	627	877.8	mW	(1)
VSYNC Frequency	F _V	-	60	-	Hz	-
DCLK Frequency	DCLK	-	33.26	-	MHz	-

Note (1) The specified power consumption is under the conditions at V_{CC}=3.3V, F_V=60Hz, whereas a power dissipation check pattern below is displayed.

Black Pattern / 0 Gray

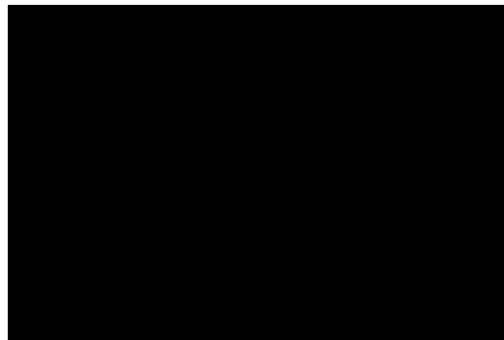

Active Area

8.2 Backlight Unit

(Ta=25±2°C)

Item	Symbol	Value			Unit	Note
		Min.	Typ.	Max.		
Current of Backlight Unit	I _B	-	260	-	mA	-
Voltage of Backlight Unit	V _B	-	9.9	-	V	I _B =260mA
Power Consumption	P _{BL}	-	(2.57)	-	W	I _B =260mA
LED Life Time(25°C)	-	30000	35000	-	hr	(1)

Note (1) : LED life time is defined as under 25±2°C , when the average brightness decrease to 50% of original brightness

DENSITRON® DISPLAYS	MODEL NO.		PAGE
	DET070WVNTCMI-1W	SPEC ONLY	8

8.3 Projected Capacitive Touch

Item	Value			Unit	Note
	Min.	Typ.	Max.		
Operating Voltage	3.0	3.3	3.6	V	-
Power Supply Current	-	11.5	17.5	mA	(1)
Power Consumption	-	33.33	51.12	mW	@3.3V
Interface	I ² C				-
Function	Multi Touch				-

Note (1) This test condition is touched with 10 points.

9. Block Diagram

9.1 TFT-LCD Module with Backlight Unit

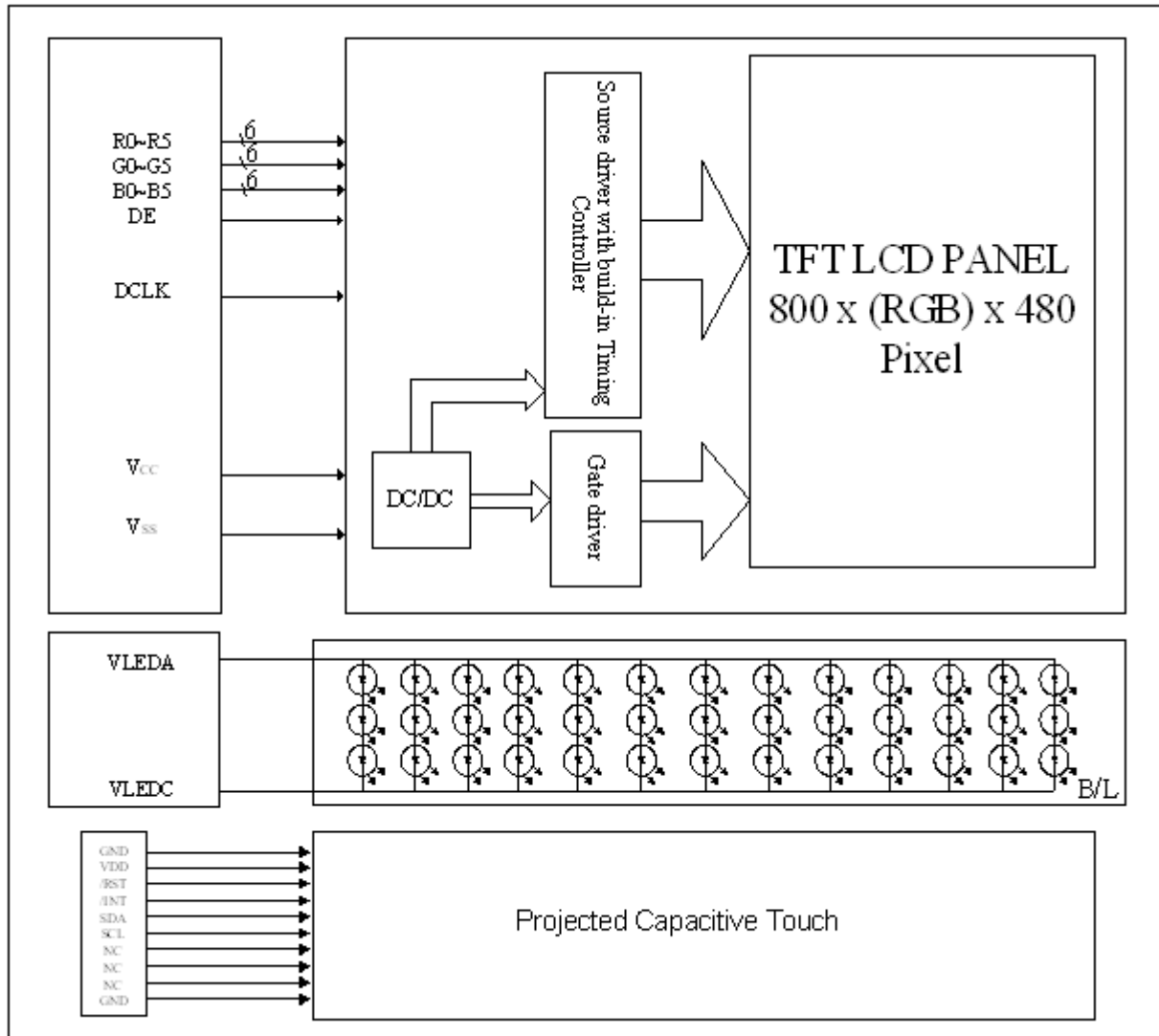

DENSITRON® DISPLAYS	MODEL NO.		PAGE
	DET070WVNTCMI-1W	SPEC ONLY	10

10. Input / Output Terminals Pin Assignment

10.1 TFT-LCD Module

Connector: JAE FA5B040HP1

Pin No.	Symbol	I/O	Description
1	V _{cc}	I	+3.3V power supply
2	V _{cc}	I	+3.3V power supply
3	V _{cc}	I	+3.3V power supply
4	V _{cc}	I	+3.3V power supply
5	NC	I	No Connect
6	DE	I	Input data enable control
7	V _{ss}	I	Ground
8	NC	I	No Connect
9	V _{ss}	I	Ground
10	NC	I	No Connect
11	V _{ss}	I	Ground
12	B5	I	Blue data(MSB)
13	B4	I	Blue data
14	B3	I	Blue data
15	V _{ss}	I	Ground
16	B2	I	Blue data
17	B1	I	Blue data
18	B0	I	Blue data(LSB)
19	V _{ss}	I	Ground
20	G5	I	GREEN data(MSB)
21	G4	I	GREEN data
22	G3	I	GREEN data
23	V _{ss}	I	Ground
24	G2	I	GREEN data
25	G1	I	GREEN data
26	G0	I	GREEN data(LSB)
27	V _{ss}	I	Ground
28	R5	I	RED data(MSB)
29	R4	I	RED data
30	R3	I	RED data

Pin No.	Symbol	I/O	Description
31	V _{ss}	I	Ground
32	R2	I	RED data
33	R1	I	RED data
34	R0	I	RED data (LSB)
35	NC	I	No Connect
36	V _{ss}	I	Ground
37	V _{ss}	I	Ground
38	DCLK	I	Dot Clock
39	V _{ss}	I	Ground
40	V _{ss}	I	Ground

10.2 Backlight Unit

Connector: JST BHSR-02VS-1(N)

Pin No.	Symbol	I/O	Description	Wire Color
1	VLEDA	I	Backlight LED Anode.	Red
2	VLEDC	I	Backlight LED Cathode.	Black

10.3 Projected Capacitive Touch

Connector: CVILUX CF25101D0R0-05

Pin No.	Symbol	I/O	Description
1	GND	I	System ground.
2	VDD	I	+3.3V power supply.
3	/RST	I	External reset signal, active low.
4	/INT	O	Interrupt signal, active low, asserted to request Host start a new transaction.
5	SDA	I/O	I ² C data signal.
6	SCL	I	I ² C clock signal.
7	NC	-	Not Connection
8	NC	-	Not Connection
9	NC	-	Not Connection
10	GND	I	System ground.

10.4 Color Data Input Assignment

The brightness of each primary color(red, green and blue) is based on the 6 bit gray scale data input for the color. The higher the binary input, the brighter the color. The table provides the assignment of color versus data input.

Color		Data Signal																	
		Red						Green						Blue					
		R5	R4	R3	R2	R1	R0	G5	G4	G3	G2	G1	G0	B5	B4	B3	B2	B1	B0
Basic Colors	Black	0	0	0	0	0	0	0	0	0	0	0	0	0	0	0	0	0	0
	Red	1	1	1	1	1	1	0	0	0	0	0	0	0	0	0	0	0	0
	Green	0	0	0	0	0	0	1	1	1	1	1	1	0	0	0	0	0	0
	Blue	0	0	0	0	0	0	0	0	0	0	0	0	1	1	1	1	1	1
	Cyan	0	0	0	0	0	0	1	1	1	1	1	1	1	1	1	1	1	1
	Magenta	1	1	1	1	1	1	0	0	0	0	0	0	1	1	1	1	1	1
	Yellow	1	1	1	1	1	1	1	1	1	1	1	1	0	0	0	0	0	0
	White	1	1	1	1	1	1	1	1	1	1	1	1	1	1	1	1	1	1
Gray Scale Of RED	Red(0) / Dark	0	0	0	0	0	0	0	0	0	0	0	0	0	0	0	0	0	0
	Red(1)	0	0	0	0	0	1	0	0	0	0	0	0	0	0	0	0	0	0
	Red(2)	0	0	0	0	1	0	0	0	0	0	0	0	0	0	0	0	0	0
	:	:	:	:	:	:	:	:	:	:	:	:	:	:	:	:	:	:	:
	:	:	:	:	:	:	:	:	:	:	:	:	:	:	:	:	:	:	:
	Red(61)	1	1	1	1	0	1	0	0	0	0	0	0	0	0	0	0	0	0
	Red(62)	1	1	1	1	1	0	0	0	0	0	0	0	0	0	0	0	0	0
	Red(63)	1	1	1	1	1	1	0	0	0	0	0	0	0	0	0	0	0	0
Gray Scale Of Green	Green(0) / Dark	0	0	0	0	0	0	0	0	0	0	0	0	0	0	0	0	0	0
	Green(1)	0	0	0	0	0	0	0	0	0	0	0	1	0	0	0	0	0	0
	Green(2)	0	0	0	0	0	0	0	0	0	0	1	0	0	0	0	0	0	0
	:	:	:	:	:	:	:	:	:	:	:	:	:	:	:	:	:	:	:
	:	:	:	:	:	:	:	:	:	:	:	:	:	:	:	:	:	:	:
	Green(61)	0	0	0	0	0	0	1	1	1	1	0	1	0	0	0	0	0	0
	Green(62)	0	0	0	0	0	0	1	1	1	1	1	0	0	0	0	0	0	0
	Green(63)	0	0	0	0	0	0	1	1	1	1	1	1	0	0	0	0	0	0
Gray Scale Of Blue	Blue(0) / Dark	0	0	0	0	0	0	0	0	0	0	0	0	0	0	0	0	0	0
	Blue(1)	0	0	0	0	0	0	0	0	0	0	0	0	0	0	0	0	0	1
	Blue(2)	0	0	0	0	0	0	0	0	0	0	0	0	0	0	0	0	1	0
	:	:	:	:	:	:	:	:	:	:	:	:	:	:	:	:	:	:	:
	:	:	:	:	:	:	:	:	:	:	:	:	:	:	:	:	:	:	:
	Blue(61)	0	0	0	0	0	0	0	0	0	0	0	0	1	1	1	1	0	1
	Blue(62)	0	0	0	0	0	0	0	0	0	0	0	0	1	1	1	1	1	0
	Blue(63)	0	0	0	0	0	0	0	0	0	0	0	0	1	1	1	1	1	1

10.5 Power ON/OFF Sequence

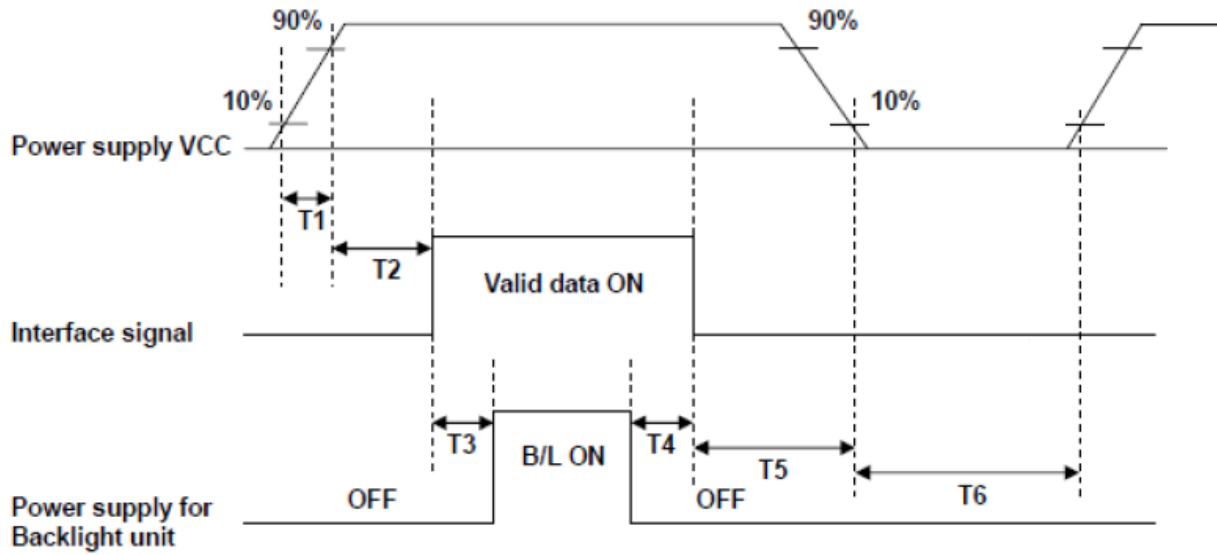

POWER SEQUENCE TABLE

Parameter	Value			Units
	Min.	Typ	Max.	
T1	0.5	-	10	ms
T2	0	-	50	ms
T3	500	-	-	ms
T4	500	-	-	ms
T5	0	-	50	ms
T6	1000	-	-	ms

DENSITRON [®] DISPLAYS	MODEL NO.		PAGE
	DET070WVNTCMI-1W	SPEC ONLY	14

11. Interface Timing

11.1 Input Signal Characteristics

PARAMETER	Symbol	Spec.			Unit
		Min.	Typ.	Max.	
DCLK frequency	F_{CPH}	-	33.26	-	MHz
DCLK period	T_{CPH}	-	30.06	-	ns
DCLK pulse duty	T_{CWH}	40	50	60	%
DE period	$T_{DEH+T_{DEL}}$	1000	1056	1200	T_{CPH}
DE pulse width	T_{DEH}	-	800	-	T_{CPH}
DE frame blanking	T_{DEB}	10	45	110	$T_{DEH+T_{DEL}}$
DE frame width	T_{DE}	-	480	-	$T_{DEH+T_{DEL}}$
Data setup time	T_{dsu}	6	-	-	ns
Data hold time	T_{dhd}	6	-	-	ns
DE setup time	T_{esu}	6	-	-	ns

11.2 Waveform

11.2.1 Clock and data input waveforms

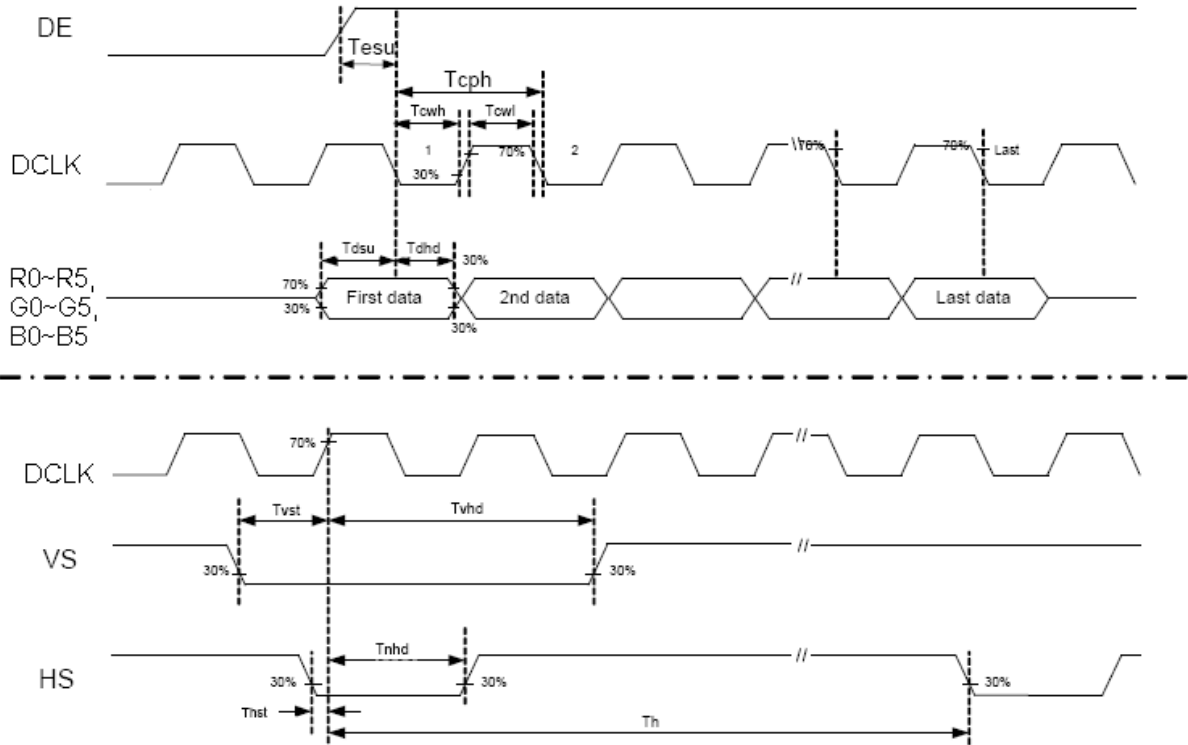

11.2.2 Data input format

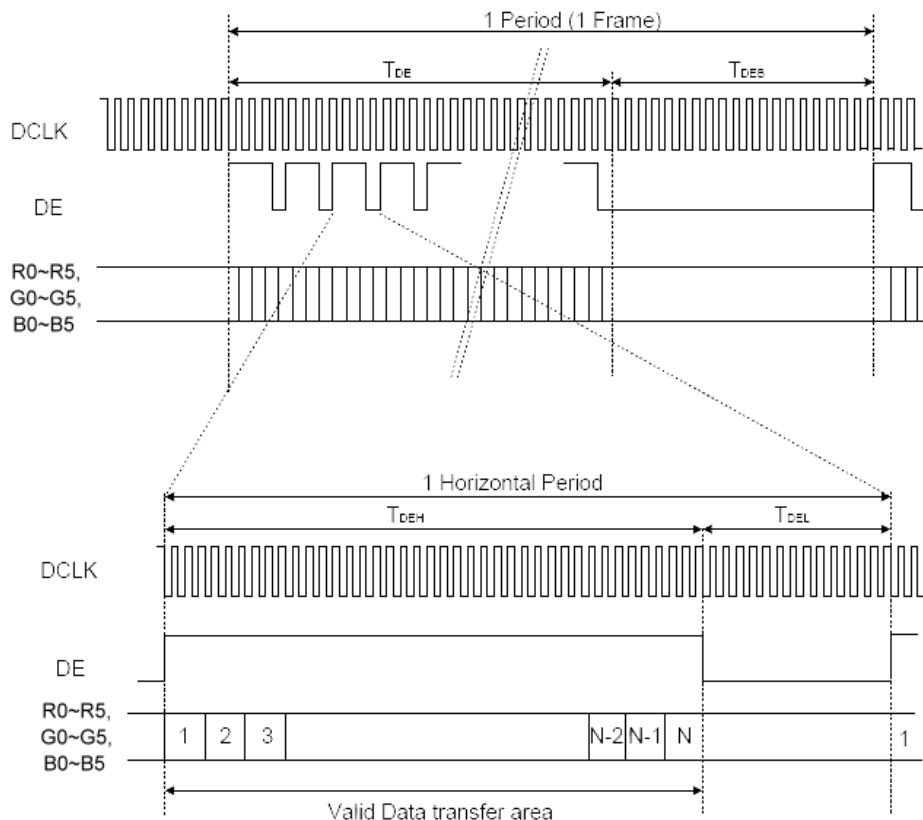

11.3 Timing Requirement of Projected Capacitive Touch

11.3.1 I2C Data Transfer Format

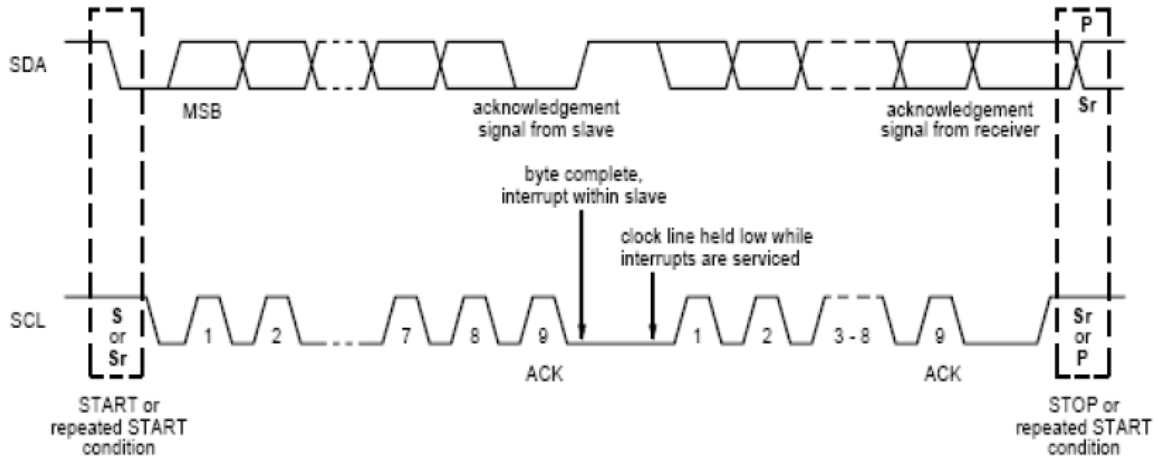

Mnemonics	Description
S	I ² C Start or I ² C Restart
A[6:0]	Slave Address = 0x70
W	1'b0: Write
R	1'b1: Read
C	ACK
P	STOP: the indicate the end of a packet (if this bit is missing, S will indicate the end of the current packet and the beginning of the next packet)

Write N bytes to I2C slave

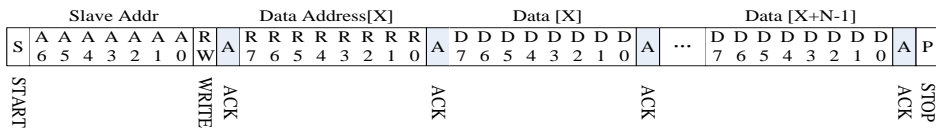

Set Data Address

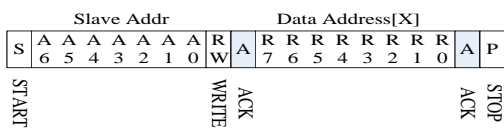

Read X bytes from I²C Slave

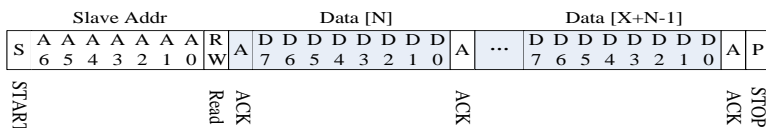

DENSITRON® DISPLAYS	MODEL NO.		PAGE
	DET070WVNTCMI-1W	SPEC ONLY	17

11.3.2 I2C Timing Characteristics

(Ta=25±2°C)

Parameter	Min	Max	Unit
SCL frequency	-	400	kHz
Bus free time between a STOP and START condition	4.7	-	μs
Hold time (repeated) START condition	4.0	-	μs
Data setup time	250	-	ns
Setup time for a repeated START condition	4.7	-	μs
Setup time for STOP condition	4.0	-	μs

11.3.3 Interrupt Trigger Mode

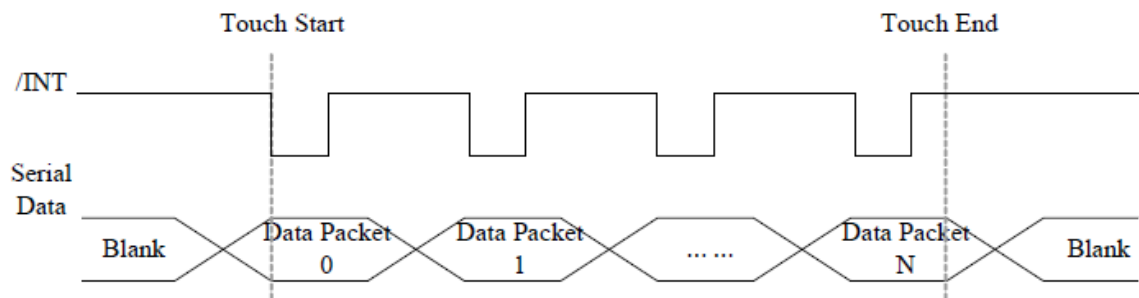

11.3.4 I2C Operating Mode Register Map

Address	Name	Bit 7	Bit 6	Bit 5	Bit 4	Bit 3	Bit 2	Bit 1	Bit 0	Host Access	
Op,00h	DEVICE_MODE		Device Mode[2:0]							RW	
Op,01h	Reserved									R	
Op,02h	TD_STATUS					Number of touch points[3:0]				R	
Op,03h	TOUCH1_YH	1 st Event Flag				1 st Touch Y Position[11:8]				R	
Op,04h	TOUCH1_YL	1 st Touch Y Position[7:0]								R	
Op,05h	TOUCH1_XH	1 st Touch ID[3:0]					1 st Touch X Position[11:8]				R
Op,06h	TOUCH1_XL	1 st Touch X Position[7:0]								R	
Op,07h	Reserved									R	
Op,08h	Reserved									R	
Op,09h	TOUCH2_YH	2 nd Event				2 nd Touch				R	

		Flag		Y Position[11:8]	
Op,0Ah	TOUCH2_YL	2 nd touch Y Position[7:0]			R
Op,0Bh	TOUCH2_XH	2 nd Touch ID[3:0]	2 nd Touch X Position[11:8]		R
Op,0Ch	TOUCH2_XL	2 nd Touch X Position[7:0]			R
Op,0Dh	Reserved				R
Op,0Eh	Reserved				R
Op,0Fh	TOUCH3_YH	3 rd Event Flag		3 rd Touch Y Position[11:8]	R
Op,10h	TOUCH3_YL	3 rd Touch Y Position[7:0]			R
Op,11h	TOUCH3_XH	3 rd Touch ID[3:0]	3 rd Touch X Position[11:8]		R
Op,12h	TOUCH3_XL	3 rd Touch X Position[7:0]			R
Op,13h	Reserved				R
Op,14h	Reserved				R
Op,15h	TOUCH4_YH	4 th Event Flag		4 th Touch Y Position[11:8]	R
Op,16h	TOUCH4_YL	4 th Touch Y Position[7:0]			R
Op,17h	TOUCH4_XH	4 th Touch ID[3:0]	4 th Touch X Position[11:8]		R
Op,18h	TOUCH4_XL	4 th Touch X Position[7:0]			R
Op,19h	Reserved				R
Op,1Ah	Reserved				R
Op,1Bh	TOUCH5_YH	5 th Event Flag		5 th Touch Y Position[11:8]	R
Op,1Ch	TOUCH5_YL	5 th Touch Y Position[7:0]			R
Op,1Dh	TOUCH5_XH	5 th Touch ID[3:0]	5 th Touch X Position[11:8]		R
Op,1Eh	TOUCH5_XL	5 th Touch X Position[7:0]			R
Op,1Fh	Reserved				R
Op,20h	Reserved				R
Op,21h	TOUCH6_YH	6 th Event Flag		6 th Touch Y Position[11:8]	R
Op,22h	TOUCH6_YL	6 th Touch Y Position[7:0]			R
Op,23h	TOUCH6_XH	6 th Touch ID[3:0]	6 th Touch X Position[11:8]		R
Op,24h	TOUCH6_XL	6 th Touch X Position[7:0]			R
Op,25h	Reserved				R

Op,26h	Reserved				R
Op,27h	TOUCH7_YH	7 th Event Flag		7 th Touch Y Position[11:8]	R
Op,28h	TOUCH7_YL	7 th Touch Y Position[7:0]			R
Op,29h	TOUCH7_XH	7 th Touch ID[3:0]		7 th Touch X Position[11:8]	R
Op,2Ah	TOUCH7_XL	7 th Touch X Position[7:0]			R
Op,2Bh	Reserved				R
Op,2Ch	Reserved				R
Op,2Dh	TOUCH8_YH	8 th Event Flag		8 th Touch Y Position[11:8]	R
Op,2Eh	TOUCH8_YL	8 th Touch Y Position[7:0]			R
Op,2Fh	TOUCH8_XH	8 th Touch ID[3:0]		8 th Touch X Position[11:8]	R
Op,30h	TOUCH8_XL	8 th Touch X Position[7:0]			R
Op,31h	Reserved				R
Op,32h	Reserved				R
Op,33h	TOUCH9_YH	9 th Event Flag		9 th Touch Y Position[11:8]	R
Op,34h	TOUCH9_YL	9 th Touch Y Position[7:0]			R
Op,35h	TOUCH9_XH	9 th Touch ID[3:0]		9 th Touch X Position[11:8]	R
Op,36h	TOUCH9_XL	9 th Touch X Position[7:0]			R
Op,37h	Reserved				R
Op,38h	Reserved				R
Op,39h	TOUCH10_YH	10 th Event Flag		10 th Touch Y Position[11:8]	R
Op,3Ah	TOUCH10_YL	10 th Touch Y Position[7:0]			R
Op,3Bh	TOUCH10_XH	10 th Touch ID[3:0]		10 th Touch X Position[11:8]	R
Op,3Ch	TOUCH10_XL	10 th Touch X Position[7:0]			R
Op,3Dh	Reserved				R
Op,3Eh	Reserved				R

DENSITRON® DISPLAYS	MODEL NO.		PAGE
	DET070WVNTCMI-1W	SPEC ONLY	20

11.3.5 DEVICE_MODE

This register is the device mode register, configure it to determine the current mode of the chip.

Address	Bit Address	Register Name	Description
Op,00h	6:4	Device Mode [2:0]	000b Normal operating Mode 001b System Information Mode (Reserved) 100b Test Mode – read raw data (Reserved)

11.3.6 TD_STATUS

This register is the Touch Data status register.

Address	Bit Address	Register Name	Description
Op,02h	3:0	Number of touch points[3:0]	How many points detected. 1-10 is valid.

11.3.7 TOUCHn_YH (n:1-10)

This register describes MSB of the Y coordinate of the nth touch point and the corresponding event flag.

Address	Bit Address	Register Name	Description
Op,03h ~ Op,39h	7:6	Event Flag	00b: Put Down 01b: Put Up 10b: Contact 11b: No event
	5:4		Reserved
	3:0	Touch Y Position [11:8]	MSB of Touch Y Position in pixels

DENSITRON® DISPLAYS	MODEL NO.		PAGE
	DET070WVNTCMI-1W	SPEC ONLY	21

11.3.8 TOUCHn_YL (n:1-10)

This register describes LSB of the Y coordinate of the nth touch point.

Address	Bit Address	Register Name	Description
Op,04h ~ Op,3Ah	7:0	Touch Y Position [7:0]	LSB of the Touch Y Position in pixels

11.3.9 TOUCHn_XH (n:1-10)

This register describes MSB of the X coordinate of the nth touch point and corresponding touch ID.

Address	Bit Address	Register Name	Description
Op,05h ~ Op,3Bh	7:4 3:0	Touch ID[3:0] Touch X Position [11:8]	Touch ID of Touch Point MSB of Touch X Position in pixels

11.3.10 TOUCHn_XL (n:1-10)

This register describes LSB of the X coordinate of the nth touch point.

Address	Bit Address	Register Name	Description
Op,06h ~ Op,3Ch	7:0	Touch X Position [7:0]	LSB of The Touch X Position in pixels

DENSITRON [®] DISPLAYS	MODEL NO.		PAGE
	DET070WVNTCMI-1W	SPEC ONLY	22

12. Optical Characteristics

The optical characteristics should be measured in a dark environment (≤ 1 lux) or equivalent state with the methods shown in Note (4).

Item		Symbol	Conditions	Min.	Typ.	Max.	Unit	Note
Contrast Ratio		CR	$\theta_x=0^\circ, \theta_y=0^\circ$ Viewing Normal Angle	150	(250)	-	-	(2)
Response Time		T _R		-	5	10	ms	(3)
		T _F		-	15	20	ms	
Luminance(Center)		Y		480	(610)	-	cd/m ²	(4)
Brightness uniformity		BUNI		70	(75)	-	%	(5)
Color Chromaticity	Red	R _x		0.540	0.590	0.640	-	(1),(4)
		R _y		0.310	0.360	0.410	-	
	Green	G _x		0.295	0.345	0.395	-	
		G _y		0.530	0.580	0.630	-	
	Blue	B _x		0.100	0.150	0.200	-	
		B _y	0.090	0.140	0.190	-		
	White	W _x	0.280	0.330	0.380	-		
		W _y	0.310	0.360	0.410	-		
Viewing Angle	Horizontal	θ_{x+}	CR \geq 10	60	(80)	-	deg.	
		θ_{x-}		60	(80)	-		
	Vertical	θ_{y+}		60	(80)	-		
		θ_{y-}		60	(80)	-		

DENSITRON® DISPLAYS	MODEL NO.		PAGE
	DET070WVNTCMI-1W	SPEC ONLY	23

Note (1) Definition of Viewing Angle (θ_x , θ_y):

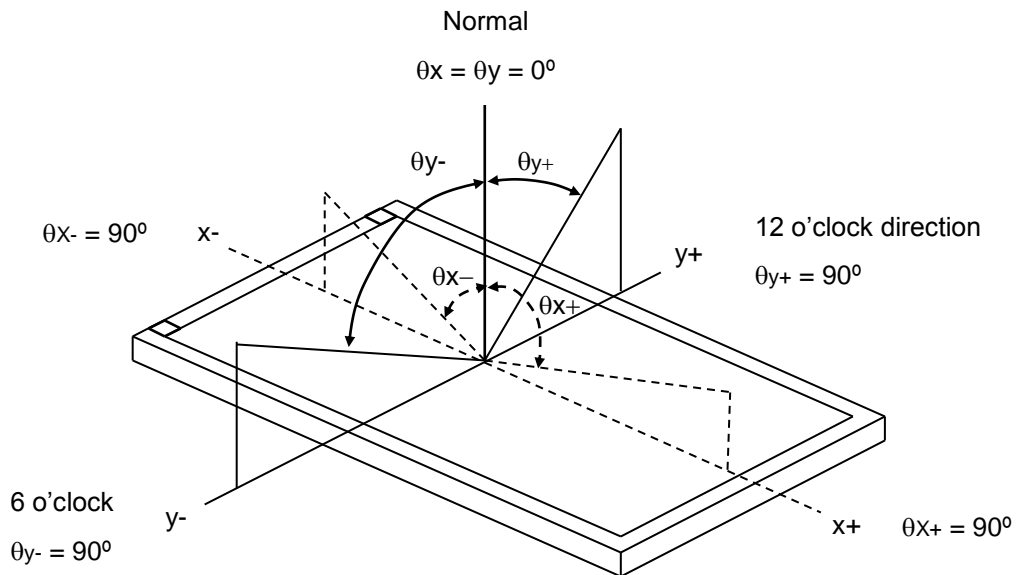

Note (2) Definition of Contrast Ratio (CR):

$$\text{Contrast ratio (CR)} = \frac{\text{Luminance measured when LCD on the "White" state}}{\text{Luminance measured when LCD on the "Black" state}}$$

Note (3) Definition of Response Time (T_R , T_F):

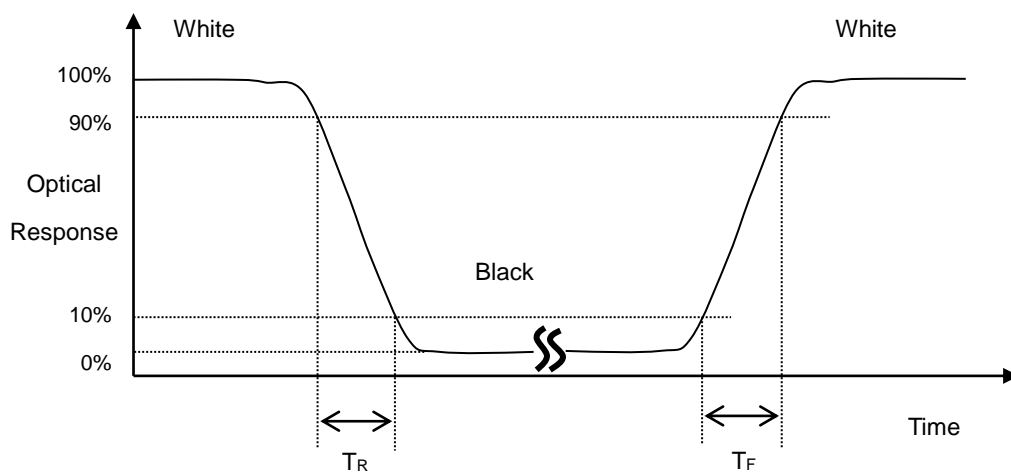

Note (4) Measurement Set-Up:

The LCD module should be stabilized at a given temperature for 30 minutes to avoid abrupt temperature change during measuring. In order to stabilize the luminance, the measurement should be executed after lighting Backlight for 30 minutes in a windless room.

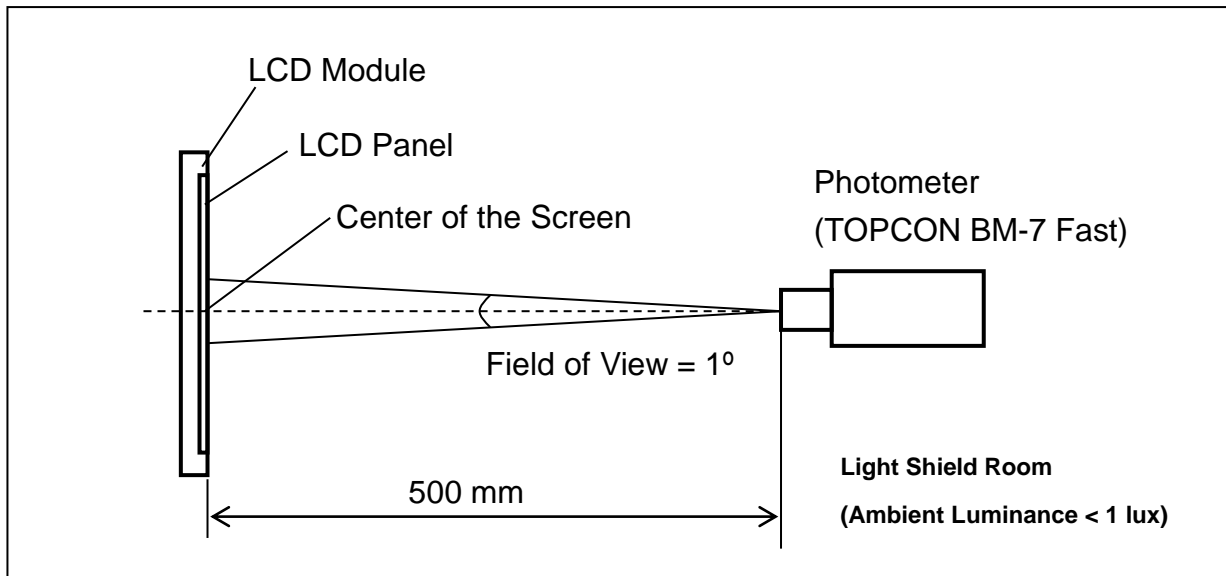

Note (5) Definition of brightness uniformity

$$\text{Brightness uniformity} = (\text{Min Luminance of 9 points}) / (\text{Max Luminance of 9 points}) \times 100\%$$

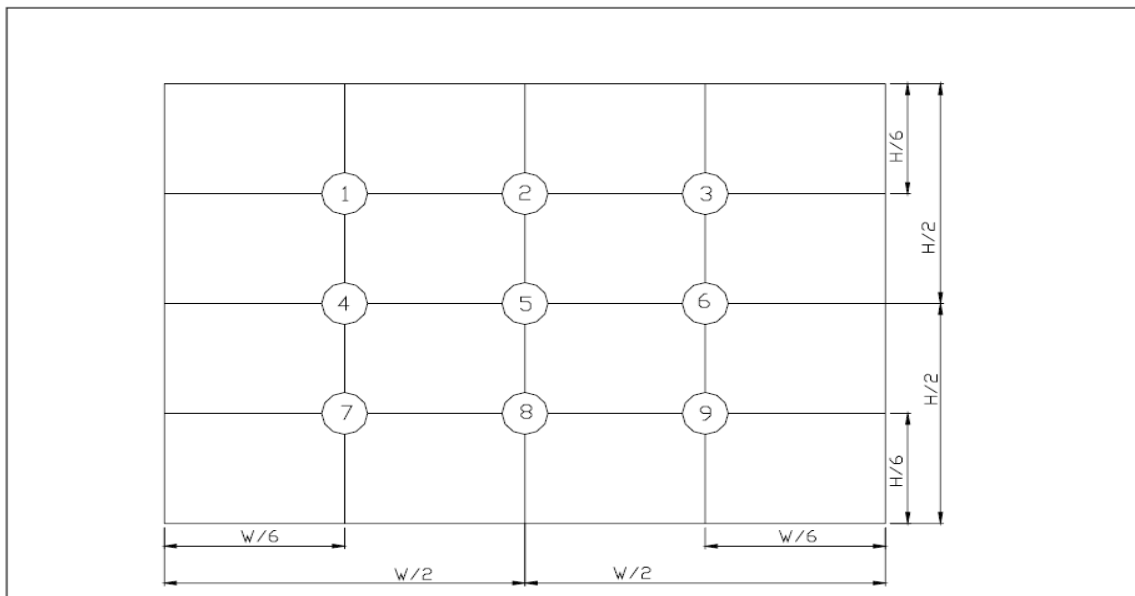

(單位 : mm)

13. Reliability Test

No.	Test Items	Test Condition	Remark
1	High Temperature Storage Test	T _a = 80°C 240 hours	(1),(3),(4)
2	Low Temperature Storage Test	T _a = -30°C 240 hours	(1),(3),(4)
3	High Temperature Operation Test	T _s = 70°C 240 hours	(2),(3),(4)
4	Low Temperature Operation Test	T _a = -20°C 240 hours	(1),(3),(4)
5	High Temperature and High Humidity Operation Test	T _a =60°C 90%RH 240 hours	(3),(4)
6	Electro Static Discharge Test (non-operating)	-Panel Surface/Top Case : 150Pf , 330Ω Air : ±15kV , Contact : ±8kV	(3)
7	Mechanical Shock Test (non-operating)	Half sine wave, 100G , 6ms 3 times shock of each six surfaces	(3)
8	Vibration Test (non-operating)	Sine wave : 10 ~ 55 ~ 10Hz amplitude:1.5mm 3 axis , 2 hours/axis	(3)
9	Thermal Shock Test (non-operating)	-20°C (30min) ~ 70°C (30min) , 10 cycles	(3),(4)
10	Drop Test(with Carton)	Height : 80cm 1 corner , 3 edges , 6 surfaces	(3)

Note 1: T_a is the ambient temperature of samples.

Note 2: T_s is the temperature of panel' s surface.

Note 3: In the standard condition, there shall be no practical problem that may affect the display function.

After the reliability test, the product only guarantees operation, but don' t guarantee all of the cosmetic specification.

Note 4: Before cosmetic and function test, the product must have enough recovery time, at least 2 hours at room temperature.

14. Packaging

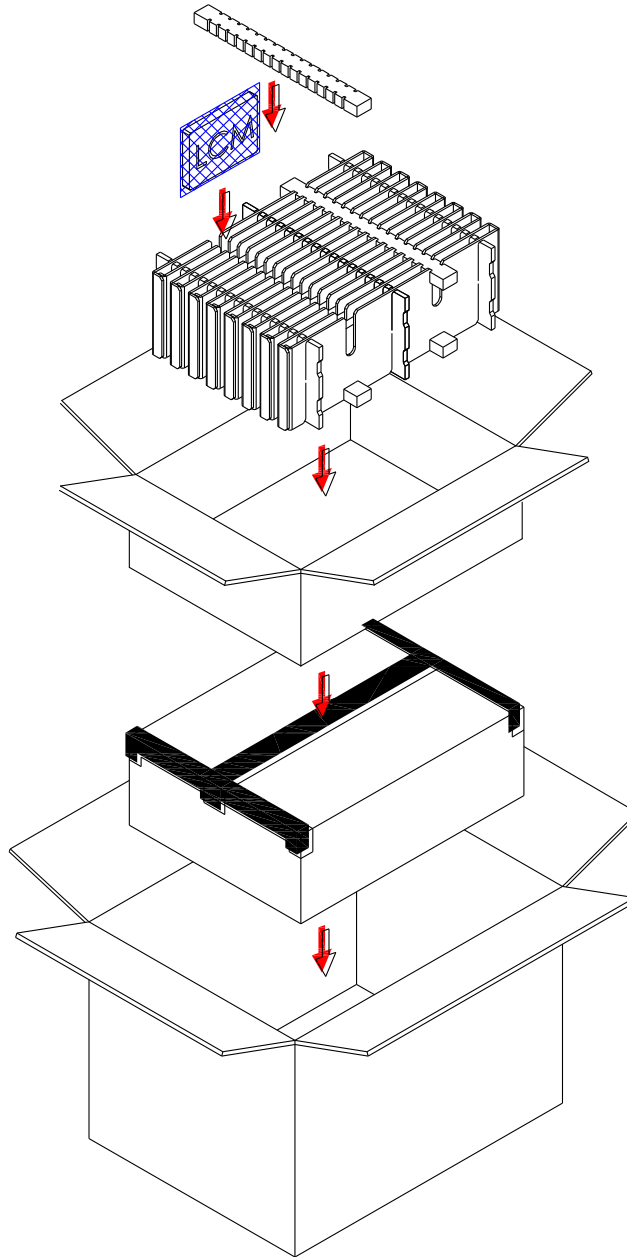

PARTS LIST					
	ITEM	SIZE(LxWxH) unit:mm	MATERIAL	Q.T.Y	NOTE
1	STATIC SHIELDING BAGS	300.0x145.0x0.09		60	
2	EPE PAD	345.0x30.0x20.0	EPE	8	
3	CARD BOARD	345.0x150.0x3.5	CARTON	6	
4	CARD BOARD	450.0x23.0x150.0	CARTON	16	
5	INTERNAL BOX	455.0x350.0x164.0	CARTON	2	
6	EXTERNAL BOX	475.0x370.0x375.0	CARTON	1	
7	PRODUCT	166.6x109.4x11.15		60	

DENSITRON® DISPLAYS	MODEL NO.		PAGE
	DET070WVNTCMI-1W	SPEC ONLY	27

15. Precautions

15.1 Assembly and Handling Precautions

- (1) Do not apply rough force such as bending or twisting to the module during assembly.
- (2) It's recommended to assemble or to install a module into the user's system in clean working areas. The dust and oil may cause electrical short or worsen the polarizer.
- (3) Don't apply pressure or impulse to the module to prevent the damage of LCD panel and Backlight.
- (4) Always follow the correct power-on sequence when the LCD module is turned on. This can prevent the damage and latch-up of the CMOS LSI chips.
- (5) Do not plug in or pull out the I/F connector while the module is in operation.
- (6) Do not disassemble the module.
- (7) Use a soft dry cloth without chemicals for cleaning, because the surface of polarizer is very soft and easily scratched.
- (8) Moisture can easily penetrate into LCD module and may cause the damage during operation.
- (9) High temperature or humidity may deteriorate the performance of LCD module. Please store LCD module in the specified storage conditions.
- (10) When ambient temperature is lower than 10°C, the display quality might be reduced. For example, the response time will become slow.

15.2 Safety Precautions

- (1) If the liquid crystal material leaks from the panel, it should be kept away from the eyes or mouth. In case of contact with hands, skin or clothes, it has to be washed away thoroughly with soap.
- (2) After the module's end of life, it is not harmful in case of normal operation and storage.

15.3 Terms of Warrant

- (1) Acceptance inspection period
The period is within one month after the arrival of contracted commodity at the buyer's factory site.
- (2) Applicable warrant period
The period is within twelve months since the date of shipping out under normal using and storage conditions.

16.Outline Drawing

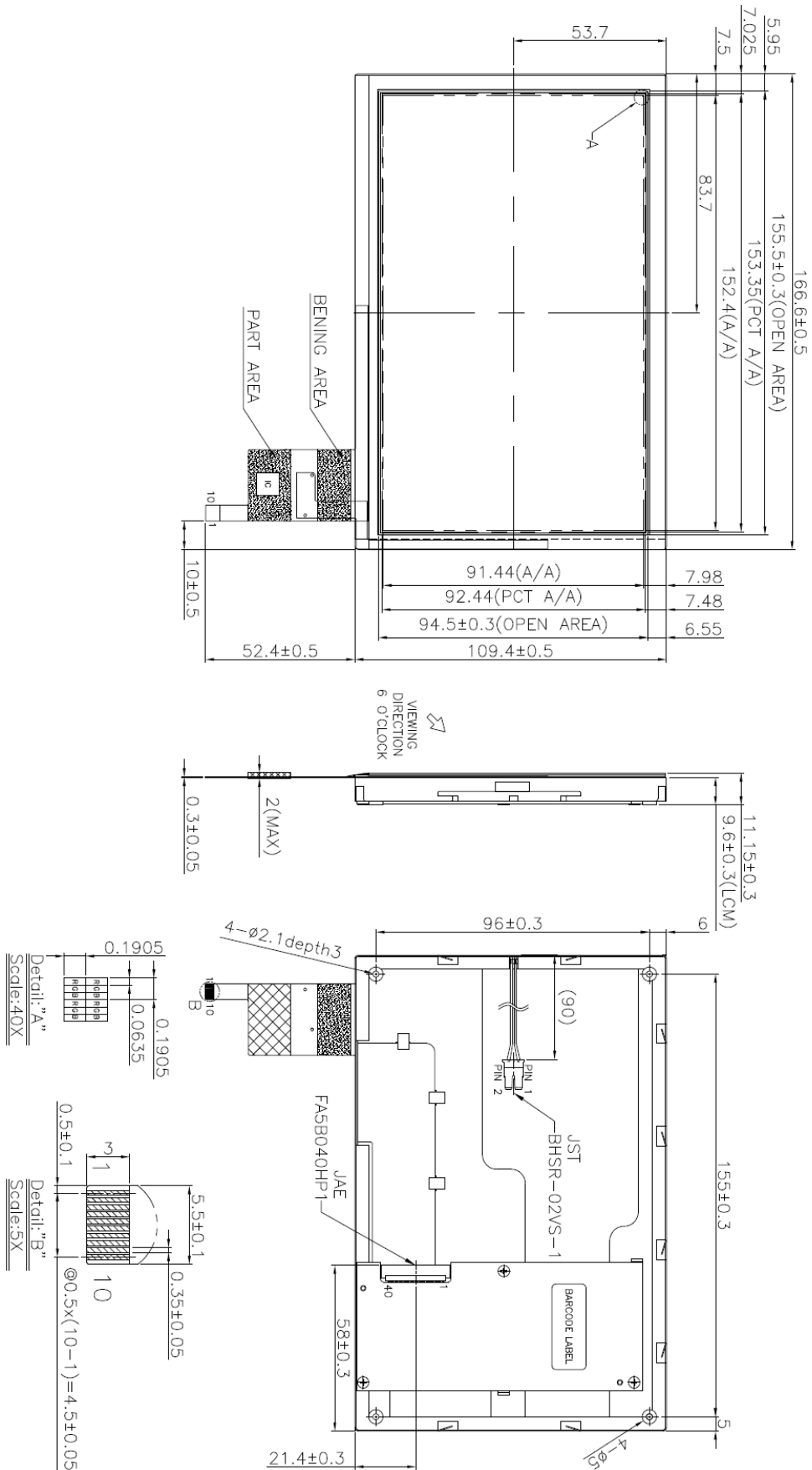

17. Incoming Inspection Standards

17.1 The environmental condition of inspection

The environmental condition and visual inspection shall be conducted as below.

- (1) Ambient temperature $25 \pm 5^{\circ}\text{C}$
- (2) Humidity: $60 \pm 5\%$ RH
- (3) Viewing distance is approximately 35 ~ 40 cm
- (4) Viewing angle is normal to the LCD panel as Fig _1(10°)
- (5) Ambient Illumination: 300 ~ 500 Lux for external appearance inspection

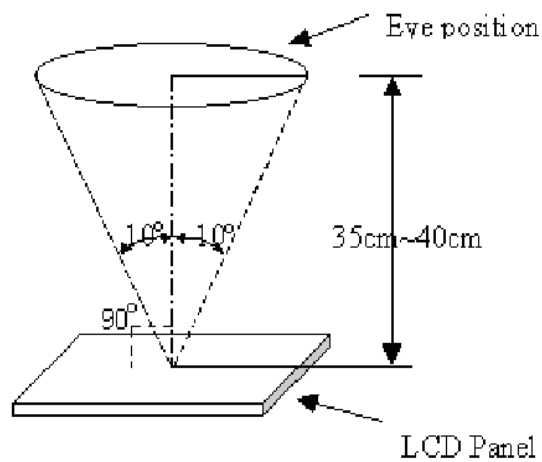

Fig _ 1

17.2 The defects classify of AQL as following:

- (1) Test method :According to [ANSI/ASQC Z 1.4](#) .General Inspection Level II take a single time
- (2) The defects classify of AQL as following:



Class of defects	AQL	Definition
Major	0.65%	It is defect that is likely to result in failure or to reduce materially the usability of the intended function.
Minor	1.5%	It is a defect that will not result in functioning problem with deviation classified.

DENSITRON® DISPLAYS	MODEL NO.		PAGE
	DET070WVNTCMI-1W	SPEC ONLY	30

17.3 Inspection Parameters

Item		Specification/Description			Note	
Display	Function	No Display			-	
		Malfunction			-	
Operating	Contrast ratio	Out of Spec			-	
	Line defect	No obvious Vertical and Horizontal line defect in bright , dark and colored.			-	
Operating	Point Defect (red,green,blue, dark, white)	Item	Acceptable number		Note: 1、4、 5、6	
			A	B		Total
		BRIGHT DOT	$N \leq 3$	$N \leq 3$		$N \leq 8$
		DARK DOT	$N \leq 5$	$N \leq 6$		
		TOTAL DOT	$N \leq 5$	$N \leq 6$		
		TWO ADJACENT DOT	NOT ALLOWED			
THREE OR MORE ADJACENT DOT	NOT ALLOWED					
External Inspection (non-operating)	Scratch on the polarizer	L(mm)	W(mm)	Acceptable number	Note:2	
		$L \leq 2.5$	$W \leq 0.1$	4		
		$L > 2.5$	$W > 0.1$	0		
	Dent or bubble on the polarizer	Dimension(mm)		Acceptable number	Note:3	
		$D \leq 0.5$		4		
		$D \leq 0.15$		Disregard		
	Line Criteria or Dot Criteria on the polarizer	Inactive dot		Acceptable number	Note:2 、3	
		$D < 0.2\text{mm}$		Disregard		
		$0.2 \leq D \leq 0.5\text{mm}$		Line & dot number $N \leq 7$		
$L \leq 1.8\text{mm}, W \leq 0.1\text{mm}$						

Incoming Inspection Touch Panel

<p>Circular Defects Linear Defects Scratch Air Bubble Crack</p>	<p>(1) Circular Defects</p> <p>$\phi = (L+W)/2$</p> <table border="1"> <thead> <tr> <th>Diameter(mm)</th> <th>Spec</th> </tr> </thead> <tbody> <tr> <td>$\phi \leq 0.2$</td> <td>No quantity limit</td> </tr> <tr> <td>$0.2 < \phi < 0.5$</td> <td>Max 5 defect</td> </tr> <tr> <td>$0.5 \leq \phi$</td> <td>Reject</td> </tr> </tbody> </table> <p>The Min distance of defects must be above 10.0mm.</p> <p>(2) Linear Defects</p> <div style="display: flex; align-items: center;">  <table border="1"> <thead> <tr> <th>Length</th> <th>Width</th> <th>Acceptable</th> </tr> </thead> <tbody> <tr> <td>$12.0 \geq L$</td> <td>$0.06 \geq W$</td> <td>Accept</td> </tr> <tr> <td>$L \geq 12.0$</td> <td>$W \geq 0.06$</td> <td>Reject</td> </tr> </tbody> </table> </div> <p>(3) Scratch</p> <table border="1"> <thead> <tr> <th>Length</th> <th>Width</th> <th>Acceptable</th> </tr> </thead> <tbody> <tr> <td>$12.0 \geq L$</td> <td>$0.06 \geq W$</td> <td>Accept</td> </tr> <tr> <td>$L \geq 12.0$</td> <td>$W \geq 0.06$</td> <td>Reject</td> </tr> </tbody> </table> <p>The Min distance of defects must be above 15.0mm.</p> <p>(4) Air Bubble</p> <table border="1"> <thead> <tr> <th>Diameter(mm)</th> <th>Spec</th> </tr> </thead> <tbody> <tr> <td>$\phi \leq 0.2$</td> <td>No quantity limit</td> </tr> <tr> <td>$0.2 < \phi \leq 0.6$</td> <td>Max 5 defect</td> </tr> </tbody> </table> <p>The Min distance of defects must be above 10.0mm.</p> <p>(5) Crack Reject</p> 	Diameter(mm)	Spec	$\phi \leq 0.2$	No quantity limit	$0.2 < \phi < 0.5$	Max 5 defect	$0.5 \leq \phi$	Reject	Length	Width	Acceptable	$12.0 \geq L$	$0.06 \geq W$	Accept	$L \geq 12.0$	$W \geq 0.06$	Reject	Length	Width	Acceptable	$12.0 \geq L$	$0.06 \geq W$	Accept	$L \geq 12.0$	$W \geq 0.06$	Reject	Diameter(mm)	Spec	$\phi \leq 0.2$	No quantity limit	$0.2 < \phi \leq 0.6$	Max 5 defect
Diameter(mm)	Spec																																
$\phi \leq 0.2$	No quantity limit																																
$0.2 < \phi < 0.5$	Max 5 defect																																
$0.5 \leq \phi$	Reject																																
Length	Width	Acceptable																															
$12.0 \geq L$	$0.06 \geq W$	Accept																															
$L \geq 12.0$	$W \geq 0.06$	Reject																															
Length	Width	Acceptable																															
$12.0 \geq L$	$0.06 \geq W$	Accept																															
$L \geq 12.0$	$W \geq 0.06$	Reject																															
Diameter(mm)	Spec																																
$\phi \leq 0.2$	No quantity limit																																
$0.2 < \phi \leq 0.6$	Max 5 defect																																

DENSITRON® DISPLAYS	MODEL NO.		PAGE
	DET070WVNTCMI-1W	SPEC ONLY	32

Note1. The definition of dot defect :

The dot defect was judged after repair and the size of a defective dot over 1/2 of whole dot is regarded as one defective dot.

Note2.

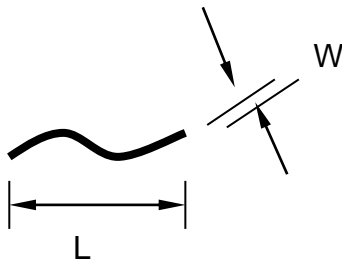

Note3. D : Diameter $D=(a+b)/2$

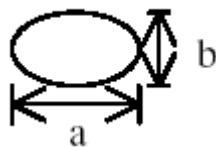

Note4. Bright dot is defined through 6% transmission ND Filter as following.

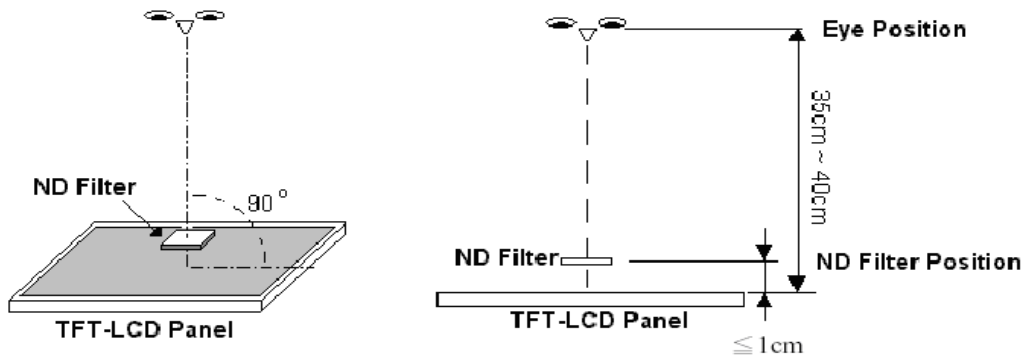

Note5. ADJACENT DOT



DENSITRON® DISPLAYS	MODEL NO.		PAGE
	DET070WVNTCMI-1W	SPEC ONLY	33

Note6.

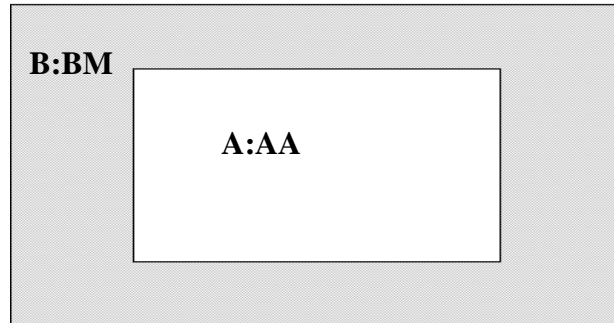

17.4 Handling of LCM

- (1) Don't give external shock.
- (2) Don't apply excessive force on the surface.
- (3) Liquid in LCD is hazardous substance. Must not lick and swallow. when the liquid is attach to your hand, skin, cloth etc. Wash it out thoroughly and immediately.
- (4) Don't operate it above the absolute maximum rating.
- (5) Don't disassemble the LCM.

X-ON Electronics

Largest Supplier of Electrical and Electronic Components

Click to view similar products for [densitron](#) manufacturer:

Other Similar products are found below :

[DMT024QVNUNT0-2C](#) [DMT028QVNTNT0S-1A](#) [DMT028QVHXCMI-1A](#) [DMT024QVNUCMI-2A](#) [LMR4048BG2C16HNG/5V](#)