

High Efficacy  
VIOLET LED Emitter  
**LZ4-00UA00**



### Key Features

- High Efficacy 10W Violet LED
- Ultra-small foot print – 7.0mm x 7.0mm
- Surface mount ceramic package with integrated glass lens
- Very low Thermal Resistance (1.1°C/W)
- Electrically neutral thermal path
- Individually addressable die
- Very high Radiant Flux density
- JEDEC Level 1 for Moisture Sensitivity Level
- Autoclave complaint (JEDEC JESD22-A102-C)
- Lead (Pb) free and RoHS compliant
- Reflow solderable (up to 6 cycles)
- Emitter available on Standard or Serially Connected MCPCB (optional)

### Typical Applications

- Dental Curing and Teeth Whitening
- Sterilization and Medical
- Ink and Adhesive Curing
- DNA Gel

### Description

The LZ4-00UA00 VIOLET LED emitter provides superior radiometric power in the wavelength range specifically required for sterilization, dental curing lights, and numerous medical applications. With a 7.0mm x 7.0mm ultra-small footprint, this package provides exceptional optical power density. The radiometric power performance and optimal peak wavelength of this LED are matched to the response curves of many dental resins, inks & adhesives, resulting in a significantly reduced curing time. The patent-pending design has unparalleled thermal and optical performance. The high quality materials used in the package are chosen to optimize light output, have excellent VIOLET resistance, and minimize stresses which results in monumental reliability and radiant flux maintenance.



## Part number options

### Base part number

Part number	Description
LZ4-00UA00-xxxx	LZ4 emitter
LZ4-40UA00-xxxx	LZ4 emitter on Standard Star 1 channel MCPCB

### Bin kit option codes

#### Single wavelength bin (5nm range)

Kit number suffix	Min flux Bin	Color Bin Range	Description
00U4	R	U4	R minimum flux; wavelength U4 bin only
00U5	S	U5	S minimum flux; wavelength U5 bin only
00U6	S	U6	S minimum flux; wavelength U6 bin only
00U7	S	U7	S minimum flux; wavelength U7 bin only
00U8	S	U8	S minimum flux; wavelength U8 bin only

## Radiant Flux Bins

Table 1:

Bin Code	Minimum Radiant Flux ( $\Phi$ ) @ $I_F = 700\text{mA}$ <sup>[1,2]</sup> (W)	Maximum Radiant Flux ( $\Phi$ ) @ $I_F = 700\text{mA}$ <sup>[1,2]</sup> (W)
R	2.40	3.00
S	3.00	3.80
T	3.80	4.80

Notes for Table 1:

1. Radiant flux performance guaranteed within published operating conditions. LED Engin maintains a tolerance of  $\pm 10\%$  on flux measurements.
2. Future products will have even higher levels of radiant flux performance. Contact LED Engin Sales for updated information.

## Peak Wavelength Bins

Table 2:

Bin Code	Minimum Peak Wavelength ( $\lambda_p$ ) @ $I_F = 700\text{mA}$ <sup>[1]</sup> (nm)	Maximum Peak Wavelength ( $\lambda_p$ ) @ $I_F = 700\text{mA}$ <sup>[1]</sup> (nm)
U4	385	390
U5	390	395
U6	395	400
U7	400	405
U8	405	410

Notes for Table 2:

1. LED Engin maintains a tolerance of  $\pm 2.0\text{nm}$  on peak wavelength measurements.

## Forward Voltage Bins

Table 3:

Bin Code	Minimum Forward Voltage ( $V_f$ ) @ $I_F = 700\text{mA}$ <sup>[1,2]</sup> (V)	Maximum Forward Voltage ( $V_f$ ) @ $I_F = 700\text{mA}$ <sup>[1,2]</sup> (V)
0	13.76	18.56

Notes for Table 3:

1. LED Engin maintains a tolerance of  $\pm 0.16\text{V}$  for forward voltage measurements.
2. Forward Voltage is binned with all four LED dice connected in series.

## Absolute Maximum Ratings

Table 4:

Parameter	Symbol	Value	Unit
DC Forward Current <sup>[1]</sup>	$I_F$	1000	mA
Peak Pulsed Forward Current <sup>[2]</sup>	$I_{FP}$	1000	mA
Reverse Voltage	$V_R$	See Note 3	V
Storage Temperature	$T_{stg}$	-40 ~ +150	°C
Junction Temperature	$T_J$	125	°C
Soldering Temperature	$T_{sol}$	260	°C
Allowable Reflow Cycles		6	
Autoclave Conditions <sup>[4]</sup>		121°C at 2 ATM, 100% RH for 168 hours	
ESD Sensitivity <sup>[5]</sup>		> 2,000 V HBM Class 2 JESD22-A114-D	

Notes for Table 4:

- Maximum DC forward current is determined by the overall thermal resistance and ambient temperature. Follow the curves in Figure 10 for current derating.
- Pulse forward current conditions: Pulse Width  $\leq$  10msec and Duty Cycle  $\leq$  10%.
- LEDs are not designed to be reverse biased.
- Autoclave Conditions per JEDEC JESD22-A102-C.
- LED Engin recommends taking reasonable precautions towards possible ESD damages and handling the LZ4-00UA00 in an electrostatic protected area (EPA). An EPA may be adequately protected by ESD controls as outlined in ANSI/ESD S6.1.

## Optical Characteristics @ $T_C = 25^\circ\text{C}$

Table 5:

Parameter	Symbol	Typical			Unit
		385-390nm	390-400nm	400-410nm	
Radiant Flux (@ $I_F = 700\text{mA}$ )	$\Phi$	2.95	3.50	3.90	W
Radiant Flux (@ $I_F = 1000\text{mA}$ )	$\Phi$	4.10	4.90	5.45	W
Peak Wavelength <sup>[1]</sup>	$\lambda_p$	385	395	405	nm
Viewing Angle <sup>[2]</sup>	$2\theta_{1/2}$		97		Degrees
Total Included Angle <sup>[3]</sup>	$\theta_{0.9V}$		120		Degrees

Notes for Table 5:

- When operating the VIOLET LED, observe IEC 60825-1 class 3B rating. Avoid exposure to the beam.
- Viewing Angle is the off axis angle from emitter centerline where the radiant power is 1/2 of the peak value.
- Total Included Angle is the total angle that includes 90% of the total radiant flux.

## Electrical Characteristics @ $T_C = 25^\circ\text{C}$

Table 6:

Parameter	Symbol	Typical		Unit
		1 Die	4 Dice	
Forward Voltage (@ $I_F = 700\text{mA}$ )	$V_F$	3.9	15.6	V
Forward Voltage (@ $I_F = 1000\text{mA}$ )	$V_F$	4.1	16.5	V
Temperature Coefficient of Forward Voltage	$\Delta V_F / \Delta T_J$		-14.2	mV/°C
Thermal Resistance (Junction to Case)	$R\theta_{J-C}$		1.1	°C/W

## IPC/JEDEC Moisture Sensitivity Level

Table 7 - IPC/JEDEC J-STD MSL-20 Classification:

Level	Floor Life		Soak Requirements			
	Time	Conditions	Standard	Accelerated	Time (hrs)	Conditions
1	Unlimited	≤ 30°C/ 85% RH	168 +5/-0	85°C/ 85% RH	n/a	n/a

Notes for Table 7:

1. The standard soak time is the sum of the default value of 24 hours for the semiconductor manufacturer's exposure time (MET) between bake and bag and the floor life of maximum time allowed out of the bag at the end user of distributor's facility.

## Average Radiant Flux Maintenance Projections

Lumen maintenance generally describes the ability of an emitter to retain its output over time. The useful lifetime for power LEDs is also defined as Radiant Flux Maintenance, with the percentage of the original light output remaining at a defined time period.

Based on long-term WHTOL testing, LED Engin projects that the LZ Series will deliver, on average, 70% Radiant Flux Maintenance (RP70%) at 20,000 hours of operation at a forward current of 700 mA per die. This projection is based on constant current operation with junction temperature maintained at or below 80°C.

## Mechanical Dimensions (mm)

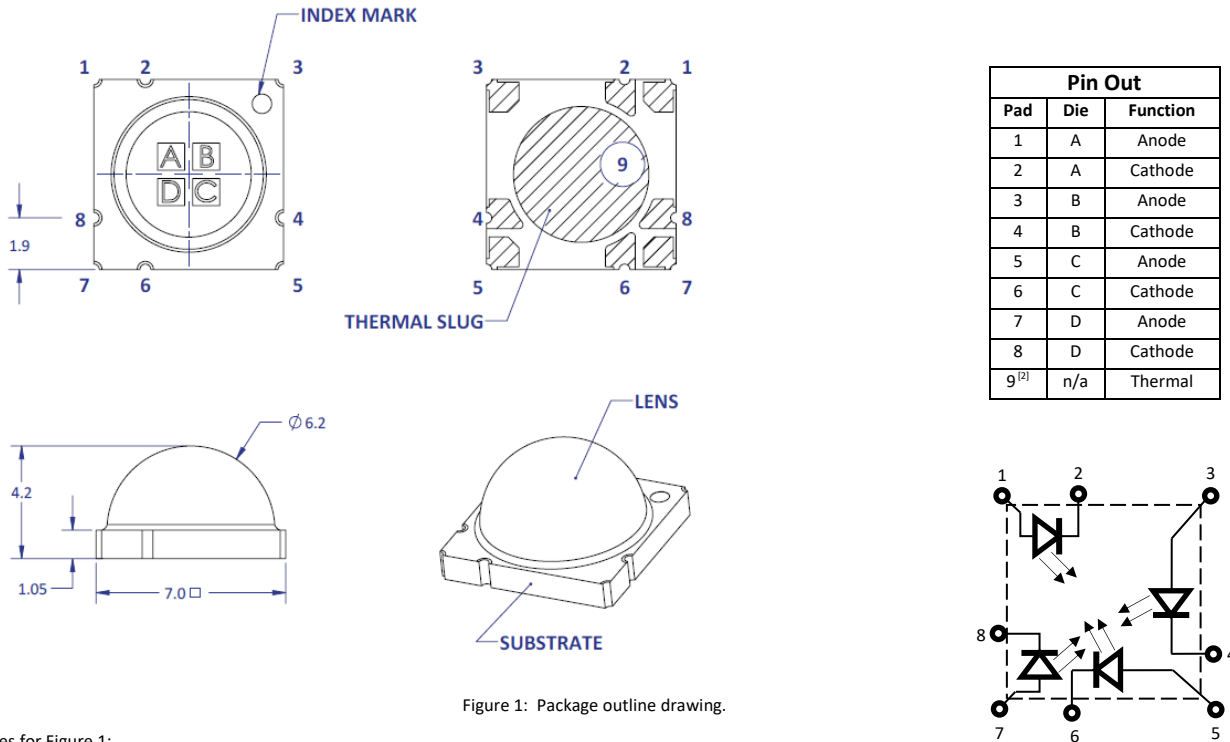

Figure 1: Package outline drawing.

Notes for Figure 1:

1. Unless otherwise noted, the tolerance =  $\pm 0.20$  mm.
2. Thermal contact, Pad 9, is electrically neutral.

## Recommended Solder Pad Layout (mm)

### Non-pedestal MCPCB Design



### Pedestal MCPCB Design

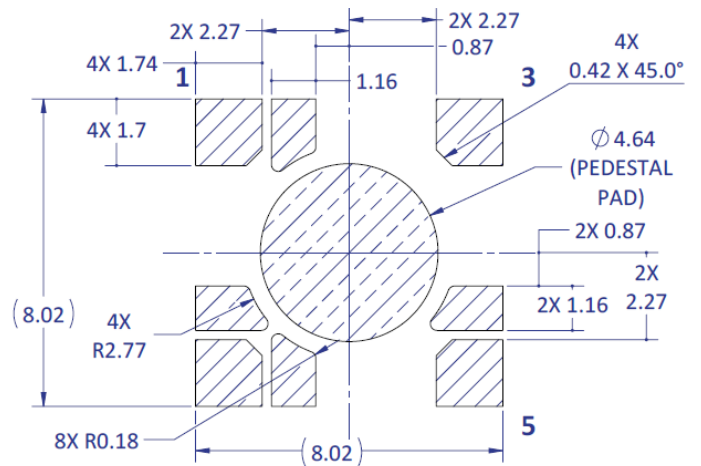

Figure 2a: Recommended solder pad layout for anode, cathode, and thermal pad for non-pedestal and pedestal design

Note for Figure 2a:

1. Unless otherwise noted, the tolerance =  $\pm 0.20$  mm.
2. Pedestal MCPCB allows the emitter thermal slug to be soldered directly to the metal core of the MCPCB. Such MCPCB eliminate the high thermal resistance dielectric layer that standard MCPCB technologies use in between the emitter thermal slug and the metal core of the MCPCB, thus lowering the overall system thermal resistance.
3. LED Engin recommends x-ray sample monitoring for solder voids underneath the emitter thermal slug. The total area covered by solder voids should be less than 20% of the total emitter thermal slug area. Excessive solder voids will increase the emitter to MCPCB thermal resistance and may lead to higher failure rates due to thermal over stress.

## Recommended Solder Mask Layout (mm)

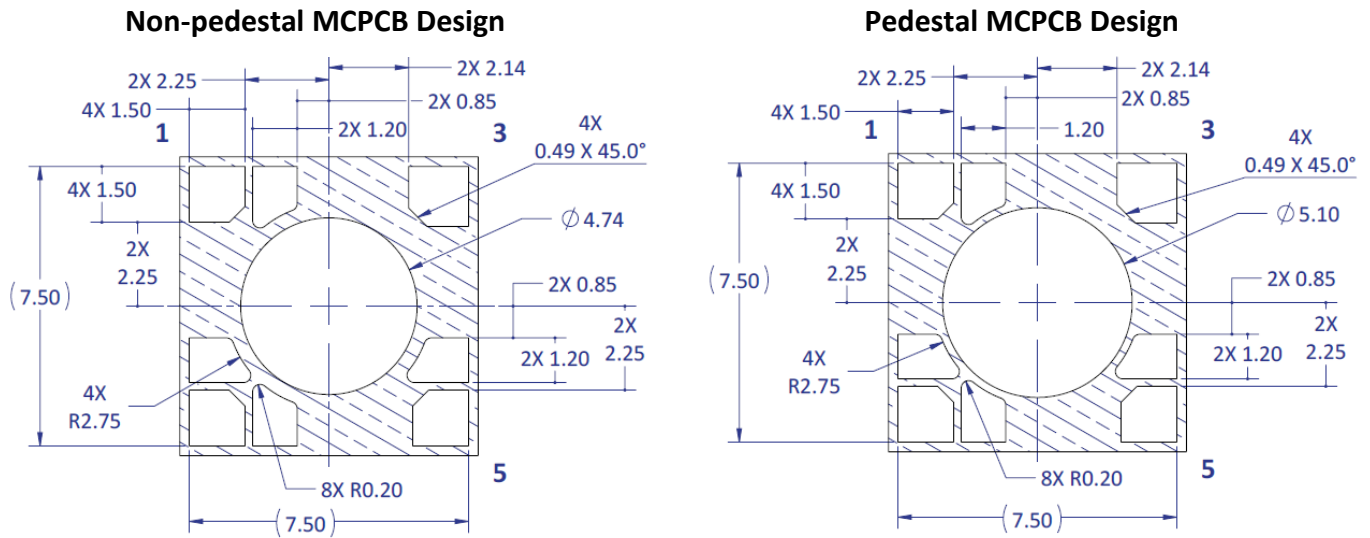

Figure 2b: Recommended solder mask opening for anode, cathode, and thermal pad for non-pedestal and pedestal design

Note for Figure 2b:

1. Unless otherwise noted, the tolerance =  $\pm 0.20$  mm.

## Recommended 8 mil Stencil Apertures Layout (mm)

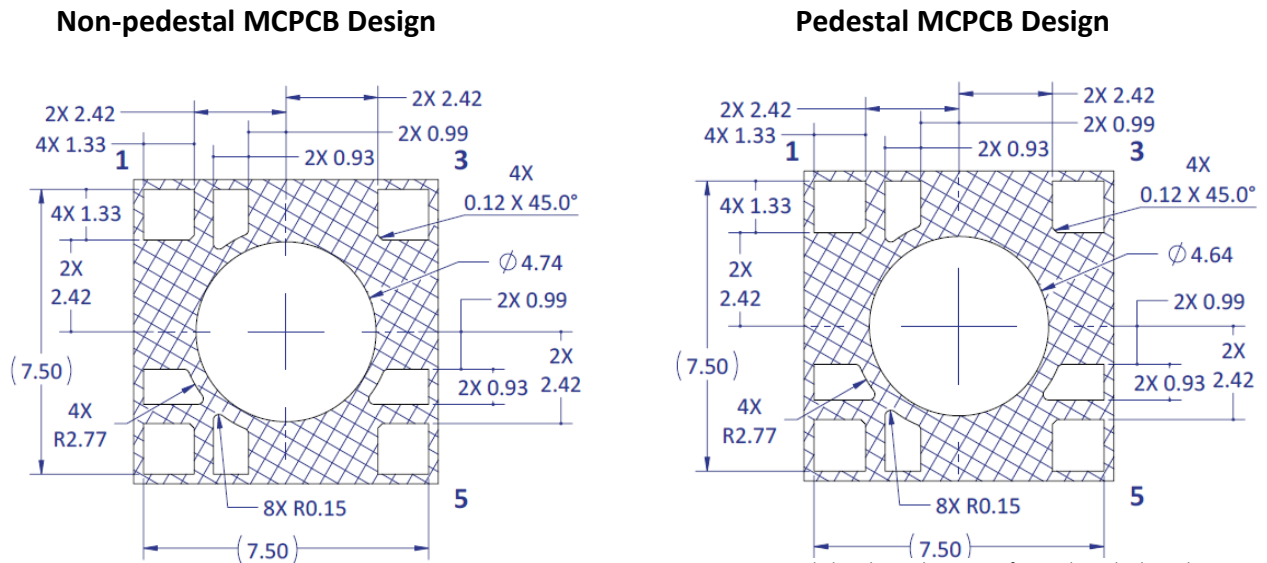

Figure 2c: Recommended 8mil stencil apertures for anode, cathode, and thermal pad for non-pedestal and pedestal design

Note for Figure 2c:

1. Unless otherwise noted, the tolerance =  $\pm 0.20$  mm.

## Reflow Soldering Profile

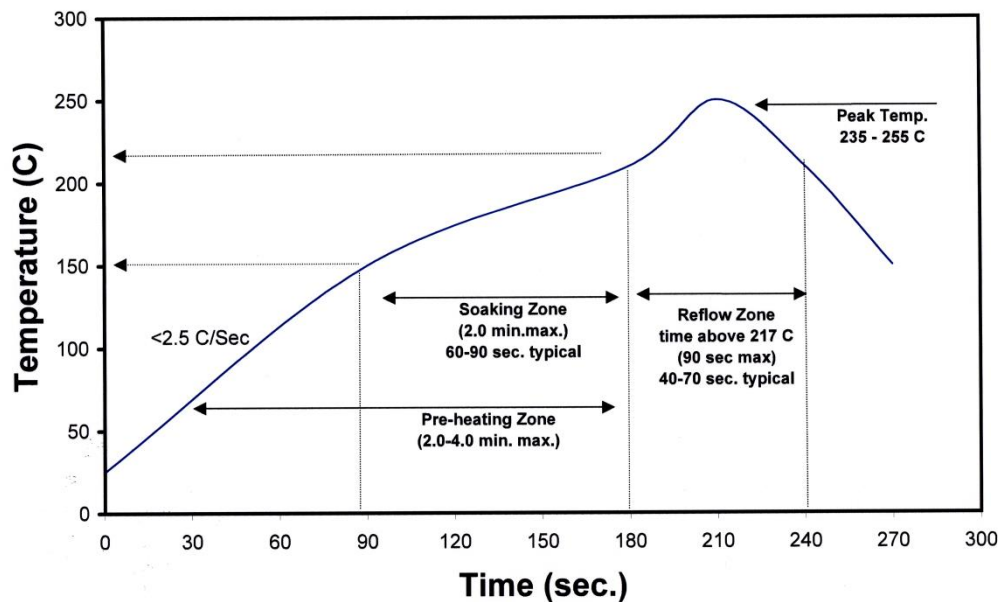

Figure 3: Reflow soldering profile for lead free soldering.

Notes for Figure 3:

1. Solder profile for low temperature solder. LED Engin recommends 58Bi-42Sn (wt.%) Solder for the LZ4-00UA00.

## Typical Radiation Pattern

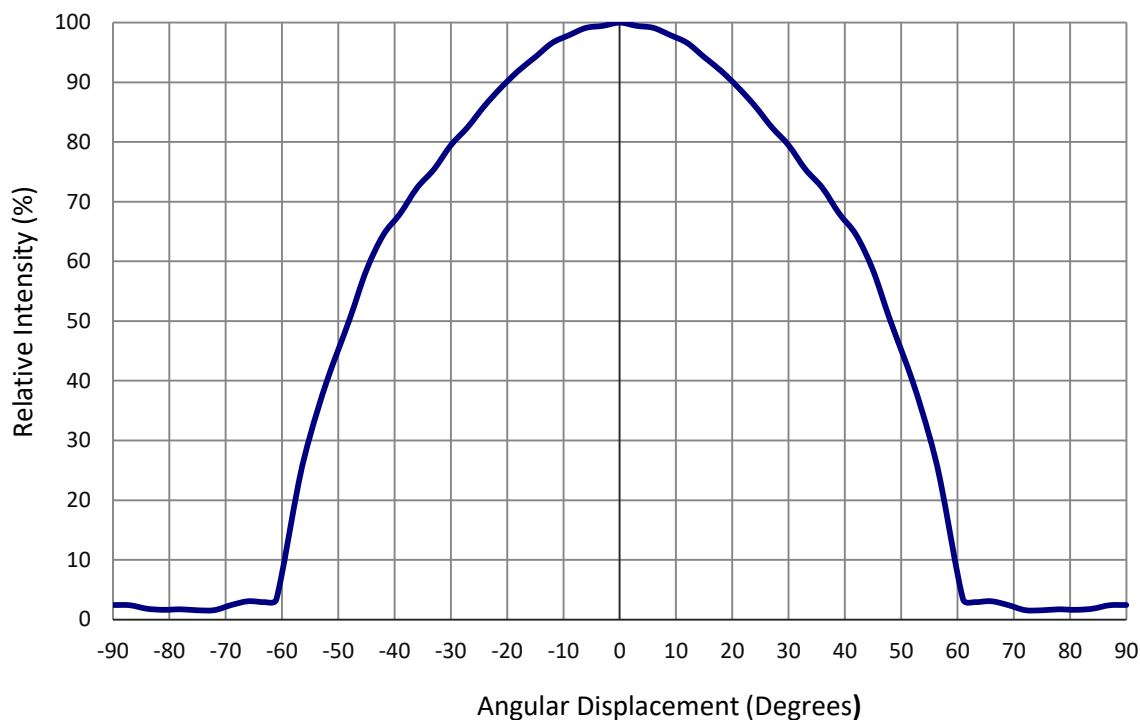

Figure 4: Typical representative spatial radiation pattern.



### Typical Relative Spectral Power Distribution

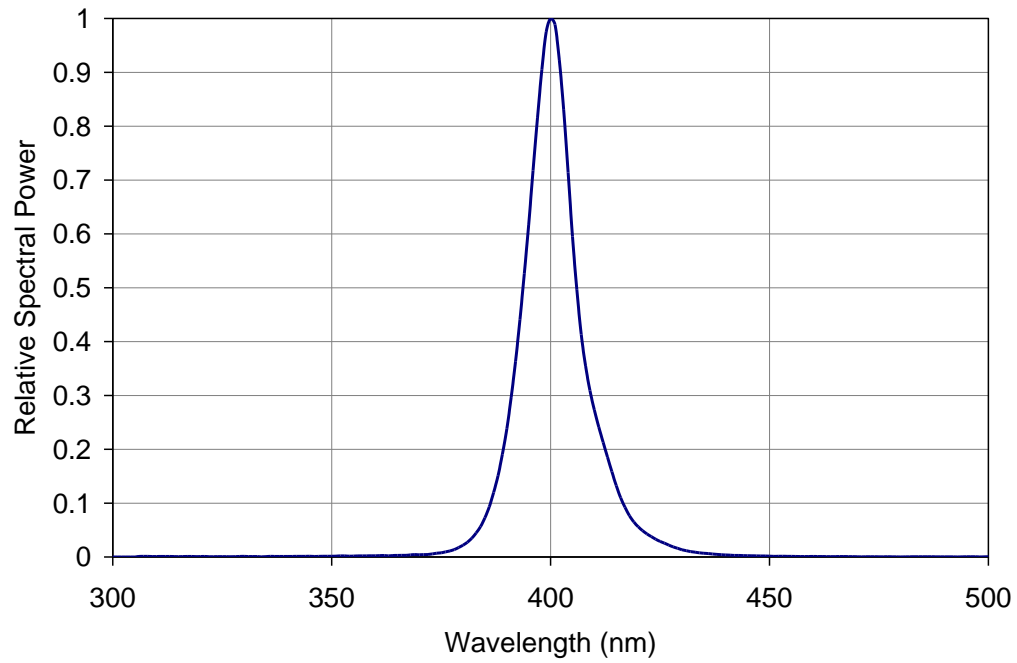

Figure 5: Typical relative spectral power vs. wavelength @ T<sub>c</sub> = 25°C.

### Typical Peak Wavelength Shift over Temperature

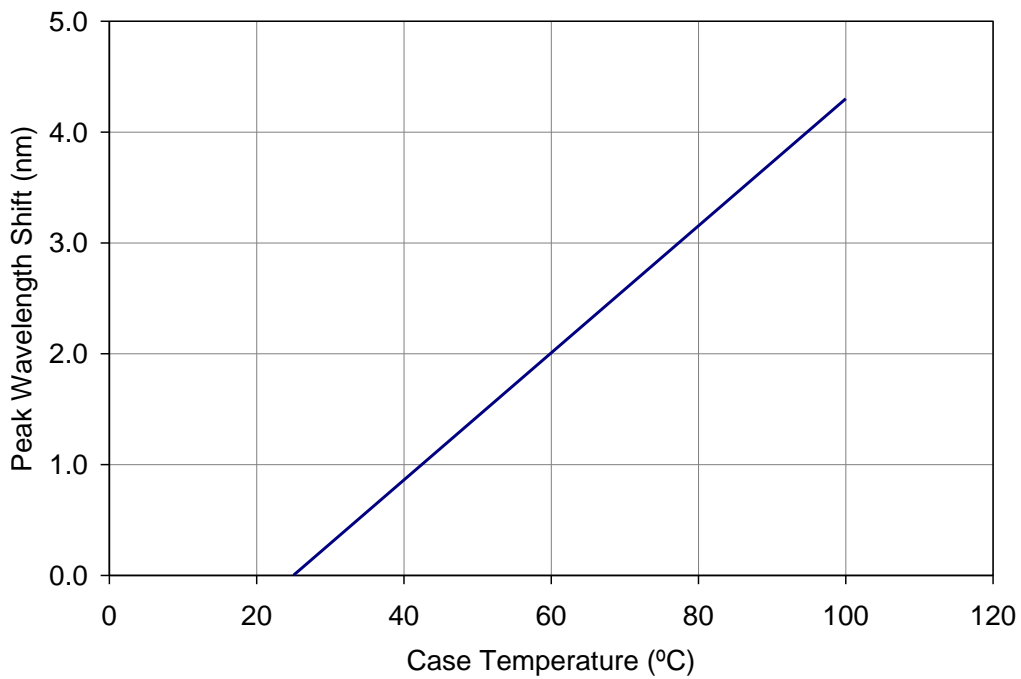

Figure 6: Typical peak wavelength shift vs. case temperature.

### Typical Normalized Radiant Flux

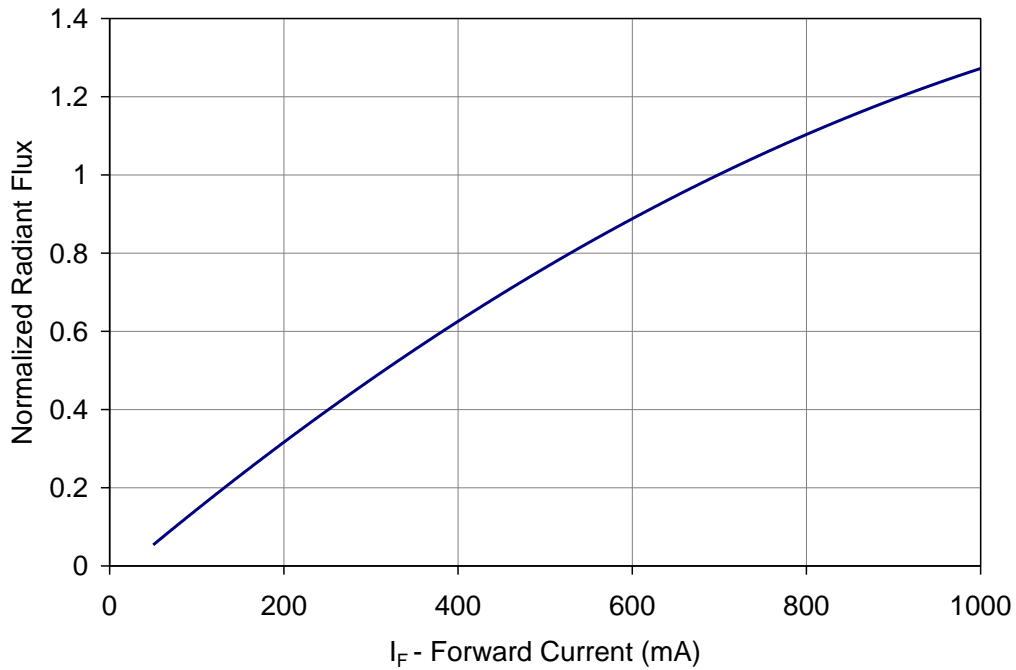

Figure 7: Typical normalized radiant flux vs. forward current @  $T_c = 25^\circ\text{C}$ .

### Typical Normalized Radiant Flux over Temperature

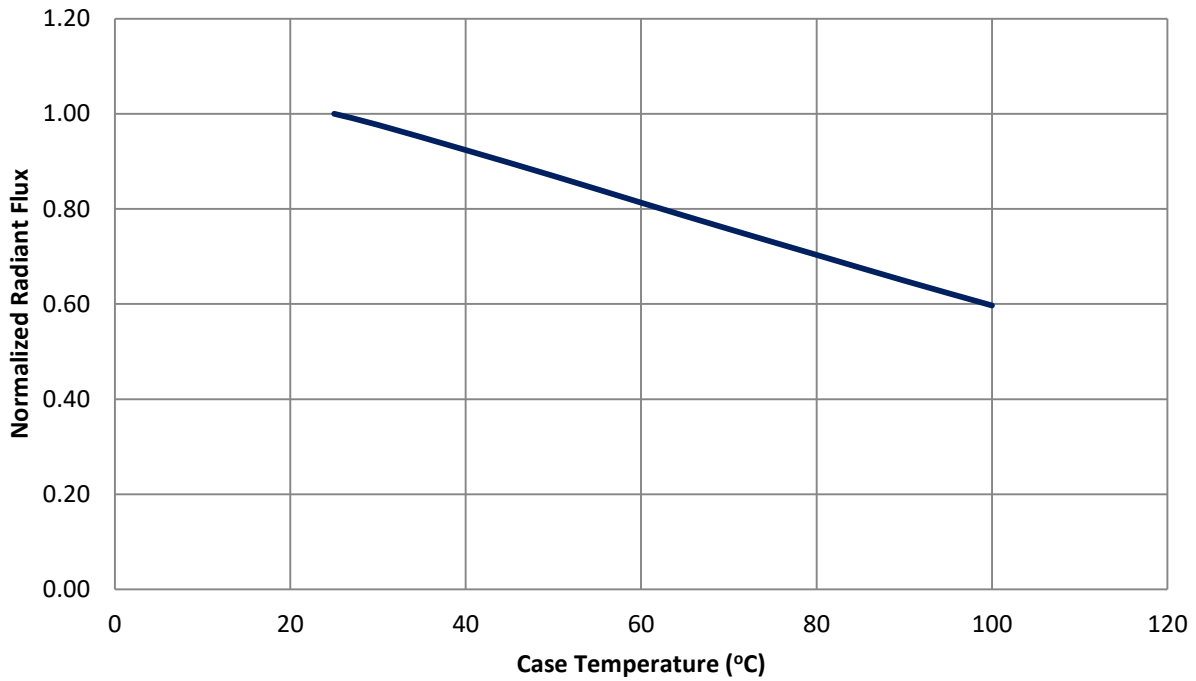

Figure 8: Typical normalized radiant flux vs. case temperature @ 700mA

### Typical Forward Current Characteristics

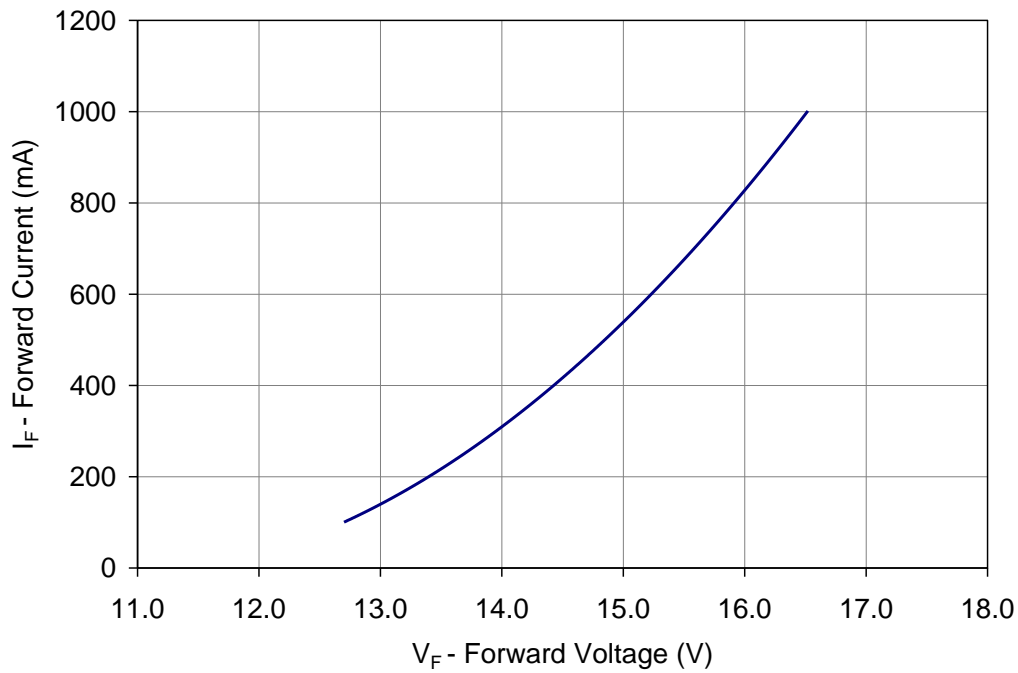

Figure 9: Typical forward current vs. forward voltage @ T<sub>C</sub> = at 25°C.

### Current De-rating

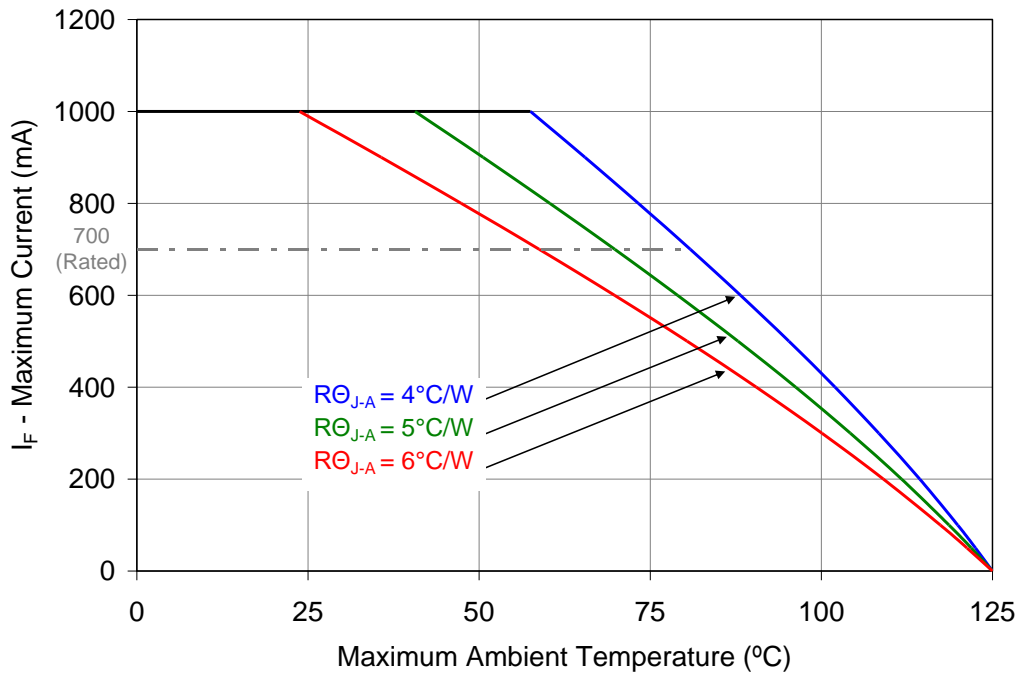

Figure 10: Maximum forward current vs. ambient temperature based on T<sub>J(MAX)</sub> = 125°C.

Notes for Figure 10:

1. R<sub>θJ-C</sub> [Junction to Case Thermal Resistance] for the LZ4-00UA00 is typically 1.1°C/W.
2. R<sub>θJ-A</sub> [Junction to Ambient Thermal Resistance] = R<sub>θJ-C</sub> + R<sub>θC-A</sub> [Case to Ambient Thermal Resistance].

## Emitter Tape and Reel Specifications (mm)

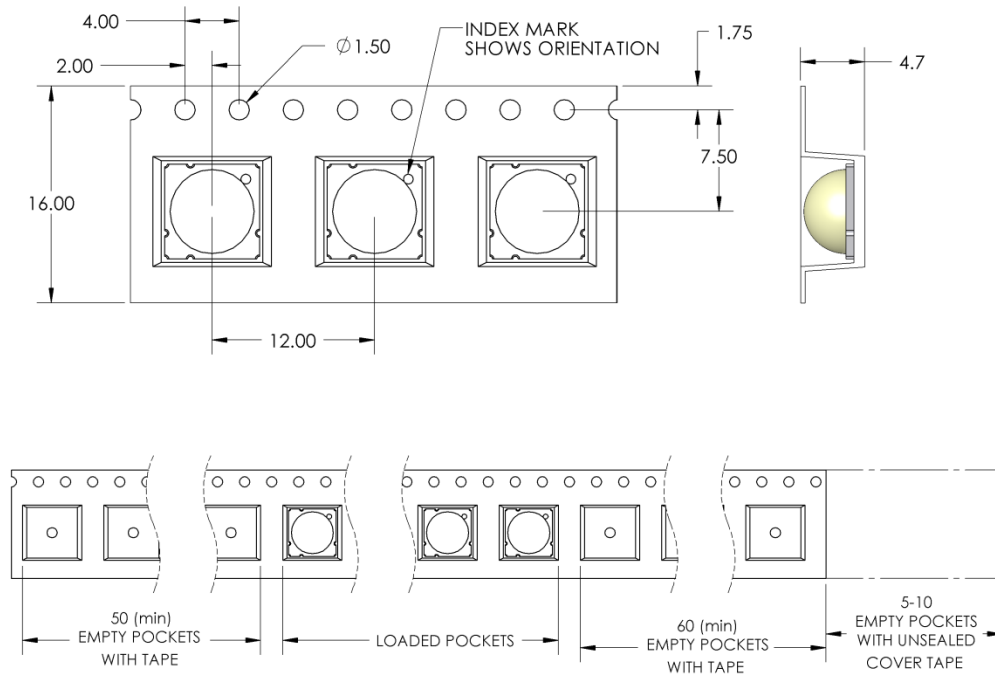

Figure 11: Emitter carrier tape specifications (mm).

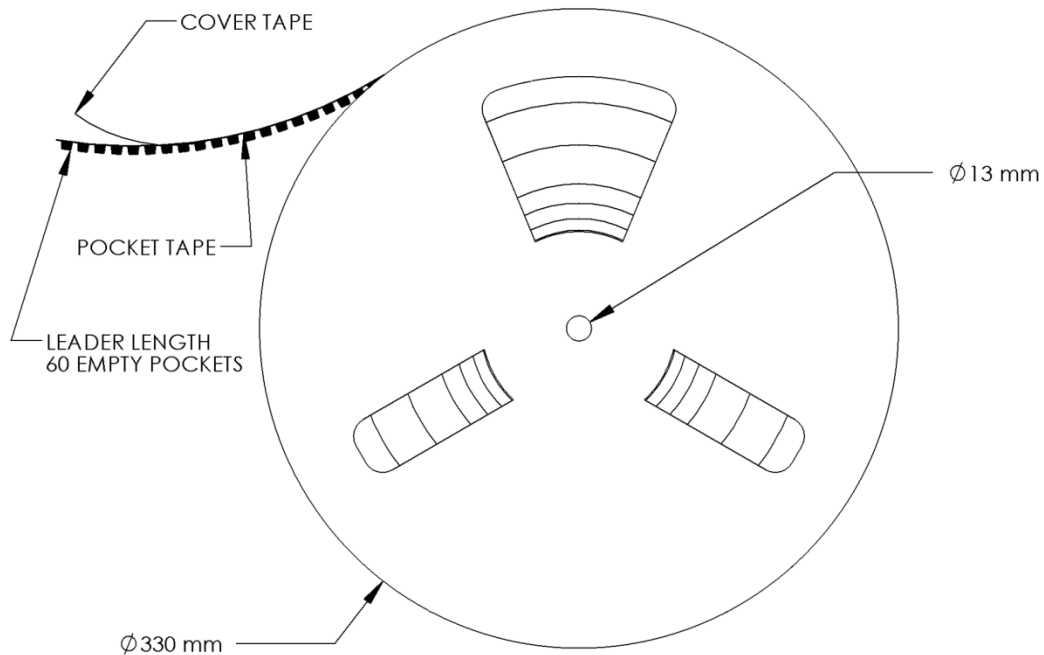

Figure 12: Emitter Reel specifications (mm).

**Notes:**

1. Packaging contains VIOLET caution labels. Avoid exposure to the beam and wear appropriate protective eyewear when operating the VIOLET LED.

# LZ4 MCPCB Family

Part number	Type of MCPCB	Diameter (mm)	Emitter + MCPCB Thermal Resistance (°C /W)	Typical V <sub>f</sub> (V)	Typical I <sub>f</sub> (mA)
LZ4-4xxxxxx	1-channel	19.9	1.1 + 1.1 = 2.2	15.6	700

## Mechanical Mounting of MCPCB

- MCPCB bending should be avoided as it will cause mechanical stress on the emitter, which could lead to substrate cracking and subsequently LED dies cracking.
- To avoid MCPCB bending:
  - Special attention needs to be paid to the flatness of the heat sink surface and the torque on the screws.
  - Care must be taken when securing the board to the heat sink. This can be done by tightening three M3 screws (or #4-40) in steps and not all the way through at once. Using fewer than three screws will increase the likelihood of board bending.
  - It is recommended to always use plastics washers in combinations with the three screws.
  - If non-taped holes are used with self-tapping screws, it is advised to back out the screws slightly after tightening (with controlled torque) and then re-tighten the screws again.

## Thermal interface material

- To properly transfer heat from LED emitter to heat sink, a thermally conductive material is required when mounting the MCPCB on to the heat sink.
- There are several varieties of such material: thermal paste, thermal pads, phase change materials and thermal epoxies. An example of such material is Electrolube EHTC.
- It is critical to verify the material's thermal resistance to be sufficient for the selected emitter and its operating conditions.

## Wire soldering

- To ease soldering wire to MCPCB process, it is advised to preheat the MCPCB on a hot plate of 125-150°C. Subsequently, apply the solder and additional heat from the solder iron will initiate a good solder reflow. It is recommended to use a solder iron of more than 60W.
- It is advised to use lead-free, no-clean solder. For example: SN-96.5 AG-3.0 CU 0.5 #58/275 from Kester (pn: 24-7068-7601)

# LZ4-4xxxxx

## 1 channel, Standard Star MCPCB (1x4) Dimensions (mm)



**Notes:**

- Unless otherwise noted, the tolerance =  $\pm 0.2$  mm.
- Slots in MCPCB are for M3 or #4-40 mounting screws.
- LED Engin recommends plastic washers to electrically insulate screws from solder pads and electrical traces.
- Electrical connection pads on MCPCB are labeled “+” for Anode and “-” for Cathode
- LED Engin recommends thermal interface material when attaching the MCPCB to a heatsink
- The thermal resistance of the MCPCB is: R $\theta$ C-B 1.1°C/W

## Components used

MCPCB: HT04503 (Bergquist)  
 ESD chips: BZX585-C30 (NXP, for 4 LED dies in series)

Pad layout			
Ch.	MCPCB Pad	String/die	Function
1	1, 2, 3	1/ABCD	Cathode -
	4, 5		Anode +

## Company Information

LED Engin, Inc., based in California’s Silicon Valley, specializes in ultra-bright, ultra compact solid state lighting solutions allowing lighting designers & engineers the freedom to create uncompromised yet energy efficient lighting experiences. The LuxiGen™ Platform — an emitter and lens combination or integrated module solution, delivers superior flexibility in light output, ranging from 3W to 90W, a wide spectrum of available colors, including whites, multi-color and UV, and the ability to deliver upwards of 5,000 high quality lumens to a target. The small size combined with powerful output allows for a previously unobtainable freedom of design wherever high-flux density, directional light is required. LED Engin’s packaging technologies lead the industry with products that feature lowest thermal resistance, highest flux density and consummate reliability, enabling compact and efficient solid state lighting solutions.

LED Engin is committed to providing products that conserve natural resources and reduce greenhouse emissions.

LED Engin reserves the right to make changes to improve performance without notice.

Please contact [sales@ledengin.com](mailto:sales@ledengin.com) or (408) 922-7200 for more information.

## X-ON Electronics

Largest Supplier of Electrical and Electronic Components

*Click to view similar products for [High Power LEDs - Single Color](#) category:*

*Click to view products by [Ledengin](#) manufacturer:*

Other Similar products are found below :

[L135-L567003500000](#) [L1CU-VLT1000000000](#) [GW PSLMS1.EC-GTHP-5J7K-1](#) [LT G5AP-CZEX-36-1](#) [ASMT-MB00-NDF00](#) [LD G5AP-4M4N-35-1](#) [XPEBRY-L1-0000-00S02](#) [XQEBLU-00-0000-000000Z02](#) [SPHWH2L3D30ED4V0H3](#) [XQEBLU-00-0000-000000202](#) [LUWCQ7P-LPLR-5E8G-1-K](#) [KA-3535SELZ4S](#) [GY CS8PM1.23-KQKS-36](#) [GH CSSPM1.24-4T2U-1](#) [L1SP-DRD0002000000](#) [L1SP-LME0002000000](#) [LHUV-0395-A060](#) [VLMTG1400-GS08](#) [XPGDRY-L1-0000-00601-SB01](#) [XTEARY-00-0000-000000L02](#) [XQEGRN-H0-0000-000000901](#) [XPEEPR-L1-0000-00B01](#) [XPERED-L1-0000-00801](#) [XTEARY-00-0000-000000M04](#) [XPGDRY-L1-0000-00401](#) [XQEEPR-00-0000-000000901](#) [XQEEPR-00-0000-000000A01](#) [15335340AA350](#) [XPCRDO-L1-R250-00701](#) [XPEGRN-L1-0000-00F02](#) [XRCRDO-L1-R250-00K03](#) [15335339AA350](#) [XQERDO-02-0000-000000701](#) [XPEBGR-L1-0000-00E02](#) [XPEROY-L1-R250-00B02](#) [15335338AA350](#) [XPEROY-L1-R250-00903](#) [XPEBRY-L1-R250-00R01](#) [XPCBLU-L1-R250-00Y01](#) [XPEGRN-L1-0000-00F01](#) [XPEBPA-L1-R250-00B01](#) [XPERED-L1-R250-00802](#) [XQEBLU-02-0000-000000305](#) [XTEARY-00-0000-000000K03](#) [XTEARY-02-0000-000000L03](#) [XPEBBL-L1-R250-00302](#) [VLMY71AAAC-GS08](#) [XPCGRN-L1-R250-00601](#) [LS H9PP-HYJY-1-1](#) [XPEROY-L1-0000-00B02](#)