

Micron StrataFlash Embedded Memory

P/N – PC28F128G18xx

P/N – PC28F256G18xx

P/N – PC28F512G18xx

P/N – PC28F00AG18xx

Features

- High-Performance Read, Program and Erase
 - 96 ns initial read access
 - 108 MHz with zero wait-state synchronous burst reads: 7 ns clock-to-data output
 - 133 MHz with zero wait-state synchronous burst reads: 5.5 ns clock-to-data output
 - 8-, 16-, and continuous-word synchronous-burst Reads
 - Programmable WAIT configuration
 - Customer-configurable output driver impedance
 - Buffered Programming: 2.0 μ s/Word (typ), 512-Mbit 65 nm
 - Block Erase: 0.9 s per block (typ)
 - 20 μ s (typ) program/erase suspend
- Architecture
 - 16-bit wide data bus
 - Multi-Level Cell Technology
 - Symmetrically-Blocked Array Architecture
 - 256-Kbyte Erase Blocks
 - 1-Gbit device: Eight 128-Mbit partitions
 - 512-Mbit device: Eight 64-Mbit partitions
 - 256-Mbit device: Eight 32-Mbit partitions
 - 128-Mbit device: Eight 16-Mbit partitions
 - Read-While-Program and Read-While-Erase
 - Status Register for partition/device status
 - Blank Check feature
- Quality and Reliability
 - Expanded temperature: -30°C to $+85^{\circ}\text{C}$
 - Minimum 100,000 erase cycles per block
 - 65nm Process Technology
- Power
 - Core voltage: 1.7V - 2.0V
 - I/O voltage: 1.7V - 2.0V
 - Standby current: 60 μ A (typ) for 512-Mbit, 65 nm
 - Deep Power-Down mode: 2 μ A (typ)
 - Automatic Power Savings mode
 - 16-word synchronous-burst read current: 23 mA (typ) @ 108 MHz; 24 mA (typ) @ 133 MHz
- Software
 - Micron[®] Flash data integrator (FDI) optimized
 - Basic command set (BCS) and extended command set (ECS) compatible
 - Common Flash interface (CFI) capable
- Security
 - One-time programmable (OTP) space
 - 64 unique factory device identifier bits
 - 2112 user-programmable OTP bits
 - Absolute write protection: $V_{PP} = \text{GND}$
 - Power-transition erase/program lockout
 - Individual zero latency block locking
 - Individual block lock-down
- Density and packaging
 - 128Mb, 256Mb, 512Mbit, and 1-Gbit
 - Address-data multiplexed and non-multiplexed interfaces
 - 64-Ball Easy BGA



Contents

General Description	8
Functional Overview	8
Configuration and Memory Map	9
Device ID	12
Package Dimensions	13
Signal Assignments	14
Signal Descriptions	15
Bus Interface	17
Reset	17
Standby	17
Output Disable	17
Asynchronous Read	18
Synchronous Read	18
Burst Wrapping	18
End-of-Wordline Delay	19
Write	20
Command Definitions	21
Status Register	24
Clear Status Register	25
Read Configuration Register	26
Programming the Read Configuration Register	27
Extended Configuration Register	28
Output Driver Control	28
Programming the Extended Configuration Register	29
Read Operations	30
Read Array	30
Read ID	30
Read CFI	31
Read Status Register	31
WAIT Operation	32
Programming Modes	33
Control Mode	33
Object Mode	34
Program Operations	38
Single-Word Programming	38
Buffered Programming	39
Buffered Enhanced Factory Programming	39
Erase Operations	42
BLOCK ERASE	42
SUSPEND and RESUME Operations	43
SUSPEND Operation	43
RESUME Operation	44
BLANK CHECK Operation	45
Block Lock	46
One-Time Programmable Operations	48
Programming OTP Area	50
Reading OTP Area	50
Global Main-Array Protection	51
Dual Operation	52
Power and Reset Specifications	53



Initialization	53
Power-Up and Down	53
Reset	53
Automatic Power Saving	55
Power Supply Decoupling	55
Electrical Specifications	56
Electrical Specifications – DC Current and Voltage Characteristics and Operating Conditions	57
Electrical Specifications – AC Characteristics and Operating Conditions	61
AC Test Conditions	61
AC Read Specifications	63
AC Read Specifications (CLK-Latching, 133 MHz)	63
AC Read Timing	64
AC Write Specifications	73
Electrical Specifications – Program/Erase Characteristics	80
Common Flash Interface	81
READ CFI Structure Output	81
CFI ID String	82
System Interface Information	82
Device Geometry Definition	83
Primary Micron-Specific Extended Query	86
Flowcharts	92
AADM Mode	109
AADM Feature Overview	109
AADM Mode Enable (RCR[4] = 1)	109
Bus Cycles and Address Capture	109
WAIT Behavior	109
Asynchronous READ and WRITE Cycles	110
Asynchronous READ Cycles	110
Asynchronous WRITE Cycles	112
Synchronous READ and WRITE Cycles	113
Synchronous READ Cycles	113
Synchronous WRITE Cycles	116
System Boot	116
Ordering Information	117
Revision History	118
Rev. F – 8/11	118
Rev. E – 8/11	118
Rev. D – 5/11	118
Rev. C – 2/11	118
Rev. B – 12/10	118
Rev. A – 12/10	118

List of Figures

Figure 1: 64-Ball Easy BGA (8mm x 10mm x 1.2mm)	13
Figure 2: 64-Ball Easy BGA (Top View, Balls Down)	14
Figure 3: Main Array Word Lines	19
Figure 4: Wrap/No-Wrap Example	19
Figure 5: End-of-Wordline Delay	19
Figure 6: Two-Cycle Command Sequence	21
Figure 7: Single-Cycle Command Sequence	21
Figure 8: READ Cycle Between WRITE Cycles	21
Figure 9: Illegal Command Sequence	22
Figure 10: Configurable Programming Regions: Control Mode and Object Mode	34
Figure 11: Configurable Programming Regions: Control Mode and Object Mode Segments	36
Figure 12: BLOCK LOCK Operations	47
Figure 13: OTP Area Map	49
Figure 14: V _{pp} Supply Connection Example	51
Figure 15: RESET Operation Waveforms	54
Figure 16: AC Input/Output Reference Waveform	61
Figure 17: Transient Equivalent Testing Load Circuit	61
Figure 18: Clock Input AC Waveform	62
Figure 19: Asynchronous Page-Mode Read (Non-MUX)	65
Figure 20: Synchronous 8- or 16-Word Burst Read (Non-MUX)	66
Figure 21: Synchronous Continuous Misaligned Burst Read (Non-MUX)	67
Figure 22: Synchronous Burst with Burst Interrupt Read (Non-MUX)	68
Figure 23: Asynchronous Single-Word Read	69
Figure 24: Synchronous 8- or 16-Word Burst Read (A/D MUX)	70
Figure 25: Synchronous Continuous Misaligned Burst Read (A/D MUX)	71
Figure 26: Synchronous Burst with Burst-Interrupt (AD-Mux)	71
Figure 27: Write Timing	74
Figure 28: Write to Write (Non-Mux)	75
Figure 29: Async Read to Write (Non-Mux)	75
Figure 30: Write to Async Read (Non-Mux)	76
Figure 31: Sync Read to Write (Non-Mux)	76
Figure 32: Write to Sync Read (Non-Mux)	77
Figure 33: Write to Write (AD-Mux)	77
Figure 34: Async Read to Write (AD-Mux)	78
Figure 35: Write to Async Read (AD-Mux)	78
Figure 36: Sync Read to Write (AD-Mux)	79
Figure 37: Write to Sync Read (AD-Mux)	79
Figure 38: Word Program Procedure	92
Figure 39: Word Program Full Status Check Procedure	93
Figure 40: Program Suspend/Resume Procedure	94
Figure 41: Buffer Programming Procedure	96
Figure 42: Buffered Enhanced Factory Programming (BEFP) Procedure	98
Figure 43: Block Erase Procedure	100
Figure 44: Block Erase Full Status Check Procedure	101
Figure 45: Erase Suspend/Resume Procedure	102
Figure 46: Block Lock Operations Procedure	104
Figure 47: Protection Register Programming Procedure	105
Figure 48: Protection Register Programming Full Status Check Procedure	106
Figure 49: Blank Check Procedure	107
Figure 50: Blank Check Full Status Check Procedure	108



Figure 51: AADM Asynchronous READ Cycle (Latching A[MAX:0]) 111
Figure 52: AADM Asynchronous READ Cycle (Latching A[15:0] only) 111
Figure 53: AADM Asynchronous WRITE Cycle (Latching A[MAX:0]) 112
Figure 54: AADM Asynchronous WRITE Cycle (Latching A[15:0] only) 113
Figure 55: AADM Synchronous Burst READ Cycle (ADV# De-asserted Between Address Cycles) 114
Figure 56: AADM Synchronous Burst READ Cycle (ADV# Not De-asserted Between Address Cycles) 115
Figure 57: AADM Synchronous Burst READ Cycle (Latching A[15:0] only) 115
Figure 58: Part Number Chart for G18 Components 117

List of Tables

Table 1: Main Array Memory Map – 128Mb, 256Mb	9
Table 2: Main Array Memory Map – 512Mb, 1Gb	10
Table 3: Device ID Codes	12
Table 4: Signal Descriptions	15
Table 5: Address Mapping for Address/Data Mux Mode	16
Table 6: Bus Control Signals	17
Table 7: Command Set	22
Table 8: Status Register Bit Definitions (Default Value = 0080h)	24
Table 9: CLEAR STATUS REGISTER Command Bus Cycles	25
Table 10: Read Configuration Register Bit Definitions	26
Table 11: Supported Clock Frequencies	26
Table 12: PROGRAM READ CONFIGURATION REGISTER Bus Cycles	27
Table 13: Extended Configuration Register Bit Definitions (Default Value = 0004h)	28
Table 14: Output Driver Control Characteristics	28
Table 15: Program Extended Configuration Register Command Bus Cycles	29
Table 16: READ MODE Command Bus Cycles	30
Table 17: Device Information	31
Table 18: WAIT Behavior Summary – Non-MUX	32
Table 19: WAIT Behavior Summary – AD MUX	32
Table 20: Programming Region Next State	37
Table 21: PROGRAM Command Bus Cycles	38
Table 22: BEFP Requirements and Considerations	40
Table 23: ERASE Command Bus Cycle	42
Table 24: Valid Commands During Suspend	43
Table 25: SUSPEND and RESUME Command Bus Cycles	44
Table 26: BLANK CHECK Command Bus Cycles	45
Table 27: BLOCK LOCK Command Bus Cycles	46
Table 28: Block Lock Configuration	47
Table 29: Program OTP Area Command Bus Cycles	48
Table 30: Dual Operation Restrictions	52
Table 31: Power Sequencing	53
Table 32: Reset Specifications	54
Table 33: Absolute Maximum Ratings	56
Table 34: Operating Conditions	56
Table 35: DC Current Characteristics and Operating Conditions	57
Table 36: DC Voltage Characteristics and Operating Conditions	60
Table 37: AC Input Requirements	61
Table 38: Test Configuration Load Capacitor Values for Worst Case Speed Conditions	61
Table 39: Capacitance	62
Table 40: AC Read Specifications (CLK-Latching, 133 MHz), $V_{CCQ} = 1.7V$ to $2.0V$	63
Table 41: AC Write Specifications	73
Table 42: Program/Erase Characteristics	80
Table 43: Example of CFI Output (x16 Device) as a Function of Device and Mode	81
Table 44: CFI Database: Addresses and Sections	81
Table 45: CFI ID String	82
Table 46: System Interface Information	82
Table 47: Device Geometry	83
Table 48: Block Region Map Information	84
Table 49: Primary Micron-Specific Extended Query	86
Table 50: One Time Programmable (OTP) Space Information	87



Table 51: Burst Read Informaton	88
Table 52: Partition and Block Erase Region Information	89
Table 53: Partition Region 1 Information: Top and Bottom Offset/Address	89
Table 54: Partition and Erase Block Map Information	91
Table 55: AADM Asynchronous and Latching Timings	110
Table 56: AADM Asynchronous Write Timings	112
Table 57: AADM Synchronous Timings	113
Table 58: Valid Line Items	117

General Description

Micron's 65nm device is the latest generation of StrataFlash® wireless memory featuring flexible, multiple-partition, dual-operation architecture. The device provides high-performance, asynchronous read mode and synchronous-burst read mode using 1.8V low-voltage, multilevel cell (MLC) technology.

The multiple-partition architecture enables background programming or erasing to occur in one partition while code execution or data reads take place in another partition. This dual-operation architecture also allows two processors to interleave code operations while PROGRAM and ERASE operations take place in the background. The multiple partitions allow flexibility for system designers to choose the size of the code and data segments.

The device is manufactured using 65nm process technologies and is available in industry-standard chip scale packaging.

Functional Overview

This device provides high read and write performance at low voltage on a 16-bit data bus. The multi-partition architecture provides read-while-write and read-while-erase capability, with individually erasable memory blocks sized for optimum code and data storage.

This device is offered in densities from 128Mb to 1Gb. The device supports synchronous burst reads up to 133 MHz using enhanced CLK latching for all densities on 45nm.

Upon initial power-up or return from reset, the device defaults to asynchronous read mode. Configuring the read configuration register enables synchronous burst mode reads. In synchronous burst mode, output data is synchronized with a user-supplied clock signal. In continuous-burst mode, a data read can traverse partition boundaries. A WAIT signal simplifies synchronizing the CPU to the memory.

Designed for low-voltage applications, the device supports READ operations with V_{CC} at 1.8V, and ERASE and PROGRAM operations with V_{PP} at 1.8V or 9.0V. V_{CC} and V_{PP} can be tied together for a simple, ultra low-power design. In addition to voltage flexibility, a dedicated V_{PP} connection provides complete data protection when V_{PP} is less than V_{PPLK} .

A status register provides status and error conditions of ERASE and PROGRAM operations.

One-time programmable (OTP) area enables unique identification that can be used to increase security. Additionally, the individual block lock feature provides zero-latency block locking and unlocking to protect against unwanted program or erase of the array.

The device offers power-savings features, including automatic power savings mode, standby mode, and deep power-down mode. For power savings, the device automatically enters APS following a READ cycle. Standby is initiated when the system deselects the device by de-asserting CE#. Deep power-down provides the lowest power consumption and is enabled by programming in the extended configuration register. DPD is initiated by asserting the DPD pin.



Configuration and Memory Map

The device features a symmetrical block architecture. The main array of the 128Mb device is divided into eight 16Mb partitions. Each partition is divided into eight 256KB blocks (8 x 8 = 64 blocks).

The main array of the 256Mb device is divided into eight 32Mb partitions. Each partition is divided into sixteen 256KB blocks (8 x 16 = 128 blocks).

The main array of the 512Mb device is divided into eight 64Mb partitions. Each partition is divided into thirty-two 256KB blocks (8 x 32 = 256 blocks).

The main array of the 1Gb device is divided into eight 128Mb partitions. Each partition is divided into sixty-four 256KB blocks (8 x 64 = 512 blocks).

Each block is divided into as many as 256 1KB programming regions. Each region is divided into as many as thirty-two 32-byte segments

Table 1: Main Array Memory Map – 128Mb, 256Mb

128Mb				256Mb		
Partition	Size (Mb)	Block #	Address Range	Size (Mb)	Block #	Address Range
7	16	63	07E0000-07FFFFFF	32	127	FF0000-FFFFFF
	
		56	0700000-071FFFF		112	FD0000-FDFFFF
6	16	55	06E0000-06FFFFFF	32	111	0DE0000-0DFFFFF
	
		48	0600000-061FFFF		96	0C00000-0C1FFFF
5	16	47	05E0000-05FFFFFF	32	95	0BE0000-0BFFFFFF
	
		40	0500000-051FFFF		80	0A00000-0A1FFFF
4	16	39	04E0000-04FFFFFF	32	79	09E0000-09FFFFFF
	
		32	0400000-041FFFF		64	0800000-081FFFF
3	16	31	03E0000-03FFFFFF	32	63	07E0000-07FFFFFF
	
		24	0300000-031FFFF		48	0600000-061FFFF



128Mb, 256Mb, 512Mb, 1Gb StrataFlash Memory Configuration and Memory Map

Table 1: Main Array Memory Map – 128Mb, 256Mb (Continued)

128Mb				256Mb		
Partition	Size (Mb)	Block #	Address Range	Size (Mb)	Block #	Address Range
2	16	23	02E0000-02FFFFFF	32	47	05E0000-05FFFFFF
	
		16	0200000-021FFFFF		32	0400000-041FFFFF
1	16	15	01E0000-01FFFFFF	32	31	03E0000-03FFFFFF
	
		8	0100000-011FFFFF		16	0200000-021FFFFF
0	16	7	00E0000-00FFFFFF	32	15	01E0000-01FFFFFF
	
		0	0000000-001FFFFF		0	0000000-001FFFFF

Table 2: Main Array Memory Map – 512Mb, 1Gb

512Mb				1Gb		
Partition	Size (Mb)	Block #	Address Range	Size (Mb)	Block #	Address Range
7	64	255	1FE0000-1FFFFFFF	128	511	3FE0000-3FFFFFFF
	
		224	1C00000-1C1FFFFF		448	3800000-381FFFFF
6	64	223	1BE0000-1BFFFFFF	128	447	37E0000-37FFFFFF
	
		192	1800000-181FFFFF		384	3000000-301FFFFF
5	64	191	17E0000-17FFFFFF	128	383	2FE0000-2FFFFFFF
	
		160	1400000-141FFFFF		320	2800000-281FFFFF



128Mb, 256Mb, 512Mb, 1Gb StrataFlash Memory Configuration and Memory Map

Table 2: Main Array Memory Map – 512Mb, 1Gb (Continued)

512Mb				1Gb		
Partition	Size (Mb)	Block #	Address Range	Size (Mb)	Block #	Address Range
4	64	159	13E0000-13FFFFFF	128	319	27E0000-27FFFFFF
	
		128	1000000-101FFFFF		256	2000000-201FFFFF
3	64	127	0FE0000-0FFFFFFF	128	255	1FE0000-1FFFFFFF
	
		96	0300000-031FFFFF		192	1800000-181FFFFF
2	64	95	0BE0000-0BFFFFFF	128	191	17E0000-17FFFFFF
	
		64	0800000-081FFFFF		128	1000000-101FFFFF
1	64	63	07E0000-07FFFFFF	128	127	0FE0000-0FFFFFFF
	
		32	0400000-041FFFFF		64	0800000-081FFFFF
0	64	31	03E0000-03FFFFFF	128	63	07E0000-07FFFFFF
	
		0	0000000-001FFFFF		0	0000000-001FFFFF



Device ID

To order parts or to obtain a data sheet, contact the factory.

Table 3: Device ID Codes

Density	Product	Device Identifier Code (Hex)
128Mb	Non-MUX	8900
	A/D MUX	8903
256Mb	Non-MUX	8901
	A/D MUX	8904
512Mb	Non-MUX	887E
	A/D MUX	8881
1024Mb	Non-MUX	88B0
	A/D MUX	88B1

Package Dimensions

Figure 1: 64-Ball Easy BGA (8mm x 10mm x 1.2mm)

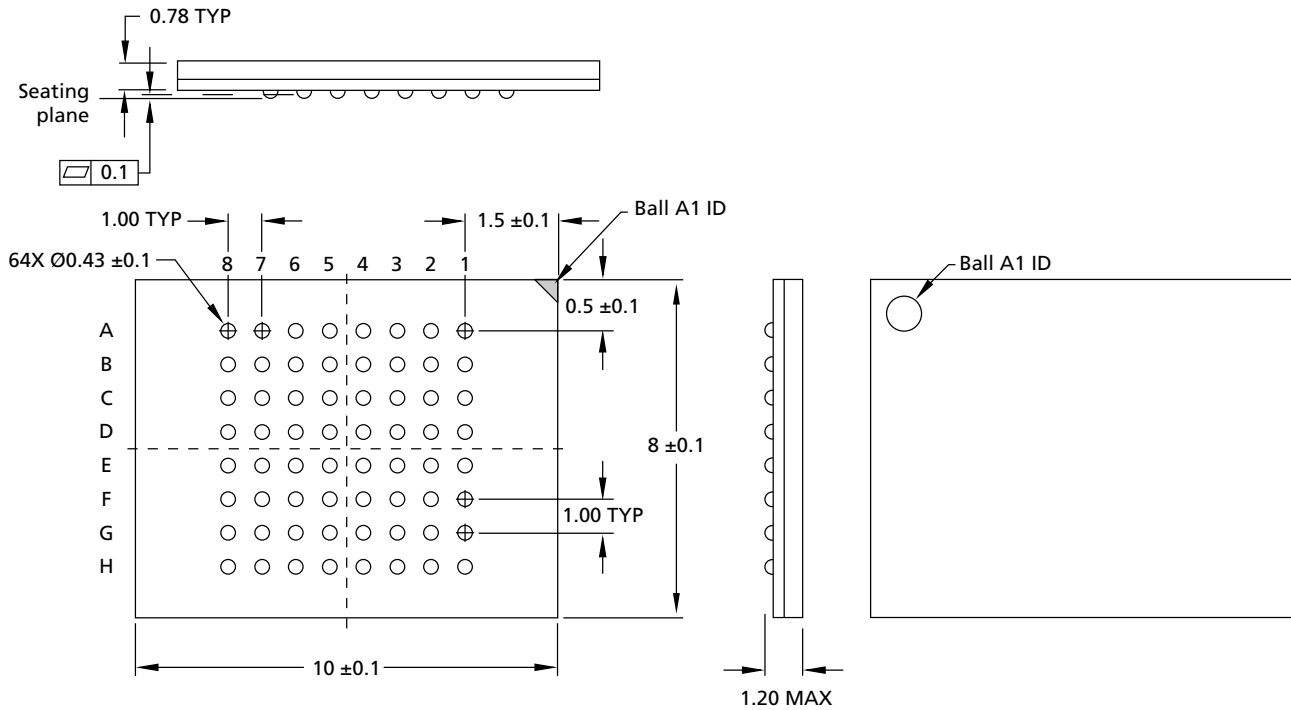

Note: 1. All dimensions are in millimeters.

Signal Assignments

Figure 2: 64-Ball Easy BGA (Top View, Balls Down)

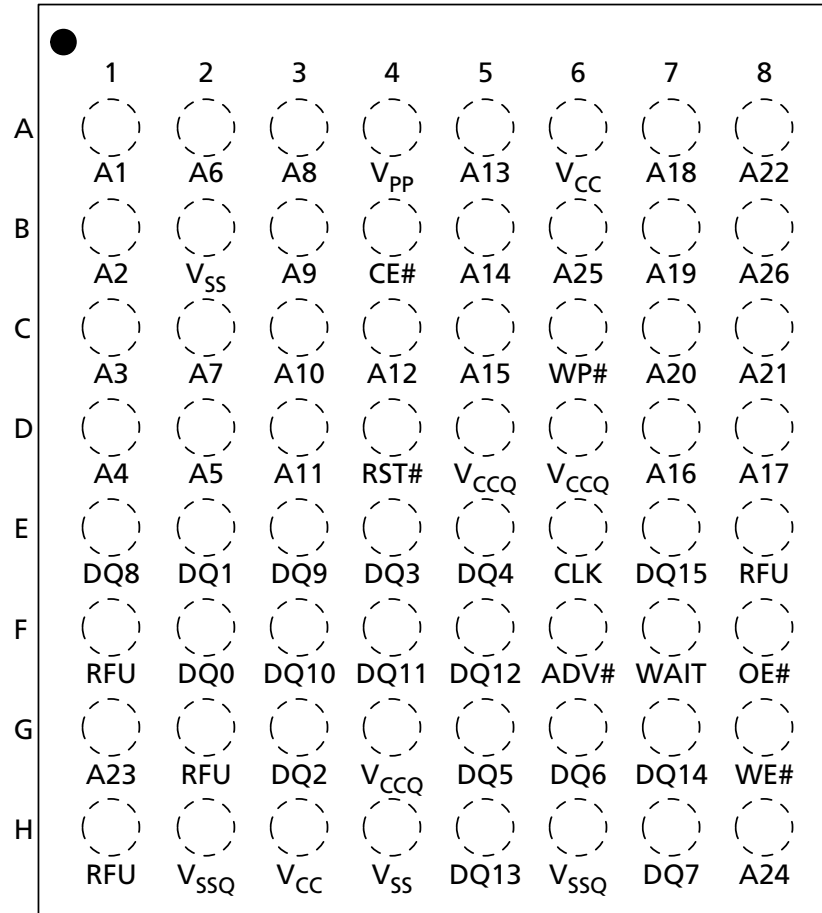

- Notes:
1. A1 is the least significant address bit.
 2. B6 is A25 for 512Mb densities and above; otherwise, it is a no connect (NC).
 3. B8 is A26 for 1Gb density; otherwise, it is a no connect (NC).
 4. G1 is A23 for 128Mb density and above; otherwise, it is a no connect (NC).
 5. H8 is A24 for 256Mb density and above; otherwise, it is a no connect (NC).

Signal Descriptions

Table 4: Signal Descriptions

Symbol	Type	Description
Non-MUX		
A[MAX:1]	Input	Address inputs: Address inputs for all READ/WRITE cycles.
DQ[15:0]	Input/Output	Data: Data or command inputs during WRITE cycles; data, status, or device information outputs during READ cycles.
A/D MUX		
A[MAX:17]	Input	Address inputs: Upper address inputs for all READ/WRITE cycles.
ADQ[15:0]	Input/Output	Address or data: Lower address inputs during the address phase for all READ/WRITE cycles; data or command inputs during WRITE cycles; data, status, or device information outputs during READ cycles.
Control Signals		
CE#	Input	Chip enable: LOW true input. When LOW, CE# selects the die; when HIGH, CE# deselects the die and places it in standby.
OE#	Input	Output enable: LOW true input. Must be LOW for READs and HIGH for WRITEs.
WE#	Input	Write enable: LOW true input. Must be LOW for WRITEs and HIGH for READs.
CLK	Input	Clock: Synchronizes burst READ operations with the host controller.
ADV#	Input	Address valid: LOW true input. When LOW, ADV# enables address inputs. For synchronous burst READs, address inputs are latched on the rising edge.
WP#	Input	Write protect: LOW true input. When LOW, WP# enables block lock down; when HIGH, WP# disables block lock down.
RST#	Input	Reset: LOW true input. When LOW, RST# inhibits all operations; must be HIGH for normal operations.
V _{PP}	Input	Erase/program voltage: Enables voltage for PROGRAM and ERASE operations. Array contents cannot be altered when V _{PP} is at or below V _{PPLK} .
WAIT	Output	WAIT: Configurable HIGH or LOW true output. When asserted, WAIT indicates DQ[15:0] is invalid; when de-asserted, WAIT indicates DQ[15:0] is valid.
V _{CC}	Power	Core power: Supply voltage for core circuits. All operations are inhibited when V _{CC} is at or below V _{LKO} .
V _{CCQ}	Power	I/O power: Supply voltage for all I/O drivers. All operations are inhibited when V _{CCQ} is at or below V _{LKOQ} .
V _{SS}	Power	Logic ground: Core logic ground return. Connect all V _{SS} balls to system ground; do not float any V _{SS} balls.
V _{SSQ}	Power	I/O ground: I/O driver ground return. Connect all V _{SSQ} balls to system ground; do not float any V _{SSQ} balls.



Table 5: Address Mapping for Address/Data Mux Mode

Address	A/D Mux Configuration	AADM Mode (RCR Bit 4 = 1) and OE# = 1	AADM Mode (RCR Bit 4 = 1) and OE# = 0
A1	DQ0	A1	A17
A2	DQ1	A2	A18
A3	DQ2	A3	A19
A4	DQ3	A4	A20
A5	DQ4	A5	A21
A6	DQ5	A6	A22
A7	DQ6	A7	A23
A8	DQ7	A8	A24
A9	DQ8	A9	A25
A10	DQ9	A10	A26
A11	DQ10	A11	–
A12	DQ11	A12	–
A13	DQ12	A13	–
A14	DQ13	A14	–
A15	DQ14	A15	–
A16	DQ15	A16	–
A17	A17	GND	GND
A18	A18	GND	GND
A19	A19	GND	GND
A20	A20	GND	GND
A21	A21	GND	GND
A22	A22	GND	GND
A23	A23	GND	GND
A24	A24	GND	GND
A25	A25	GND	GND
A26	A26	GND	GND

Bus Interface

The bus interface uses CMOS-compatible address, data, and bus control signals for all bus WRITE and bus READ operations. The address signals are input only, the data signals are input/output (I/O), and the bus control signals are input only. The address inputs are used to specify the internal device location during bus READ and bus WRITE operations. The data I/Os carry commands, data, or status to and from the device. The control signals are used to select and deselect the device, indicate a bus READ or bus WRITE operation, synchronize operations, and reset the device.

Do not float any inputs. All inputs must be driven or terminated for proper device operation. Some features may use additional signals. See Signal Descriptions for descriptions of these signals.

The following table shows the logic levels that must be applied to the bus control signal inputs for the bus operations listed.

Table 6: Bus Control Signals

X = Don't Care; High = V_{IH} ; Low = V_{IL}

Bus Operations	RST#	CE#	CLK	ADV#	OE#	WE#	Address	Data I/O
Reset	Low	X	X	X	X	X	X	High-Z
Standby	High	High	X	X	X	X	X	High-Z
Output Disable	High	X	X	X	High	X	X	High-Z
Asynchronous Read	High	Low	X	Low	Low	High	Valid	Output
Synchronous Read	High	Low	Running	Toggle	Low	High	Valid	Output
Write	High	Low	X	X	High	Low	Valid	Input

Reset

RST# LOW places the device in reset, where device operations are disabled; inputs are ignored, and outputs are placed in High-Z.

Any ongoing ERASE or PROGRAM operation will be aborted and data at that location will be indeterminate.

RST# HIGH enables normal device operations. A minimum delay is required before the device is able to perform a bus READ or bus WRITE operation. See AC specifications.

Standby

RST# HIGH and CE# HIGH place the device in standby, where all other inputs are ignored, outputs are placed in High-Z (independent of the level placed on OE#), and power consumption is substantially reduced.

Any ongoing ERASE or PROGRAM operation continues in the background and the device draws active current until the operation has finished.

Output Disable

When OE# is deasserted with CE# asserted, the device outputs are disabled. Output pins are placed in a high-impedance state. WAIT is deasserted in AD-muxed devices and driven to High-Z in non-multiplexed devices.

Asynchronous Read

For RCR15 = 1 (default), CE# LOW and OE# LOW place the device in asynchronous bus read mode:

- RST# and WE# must be held HIGH; CLK must be tied either HIGH or LOW.
- Address inputs must be held stable throughout the access, or latched with ADV#.
- ADV# must be held LOW or can be toggled to latch the address.
- Valid data is output on the data I/Os after ^tAVQV, ^tELQV, ^tVLQV, or ^tGLQV, whichever is satisfied last.

Asynchronous READ operations are independent of the voltage level on V_{PP}.

For asynchronous page reads, subsequent data words are output ^tAPA after the least significant address bit(s) are toggled: 16-word page buffer, A[3:0].

Synchronous Read

For RCR15 = 0, CE# LOW, OE# LOW, and ADV# LOW place the device in synchronous bus read mode:

- RST# and WE# must be held HIGH.
- CLK must be running.
- The first data word is output ^tCHQV after the latency count has been satisfied.
- For array reads, the next address data is output ^tCHQV after valid CLK edges until the burst length is satisfied.
- For nonarray reads, the same address data is output ^tCHQV after valid CLK edges until the burst length is satisfied.

The address for synchronous read operations is latched on the ADV# rising edge or the first rising CLK edge after ADV# low, whichever occurs first for devices that support up to 108 MHz. For devices that support up to 133 MHz, the address is latched on the last CLK edge when ADV# is low.

Burst Wrapping

Data stored within the memory array is arranged in rows or word lines. During synchronous burst reads, data words are sensed in groups from the array. The starting address of a synchronous burst read determines which word within the wordgroup is output first, and subsequent words are output in sequence until the burst length is satisfied.

The setting of the burst wrap bit (RCR3) determines whether synchronous burst reads will wrap within the wordgroup or continue on to the next wordgroup.

Figure 3: Main Array Word Lines

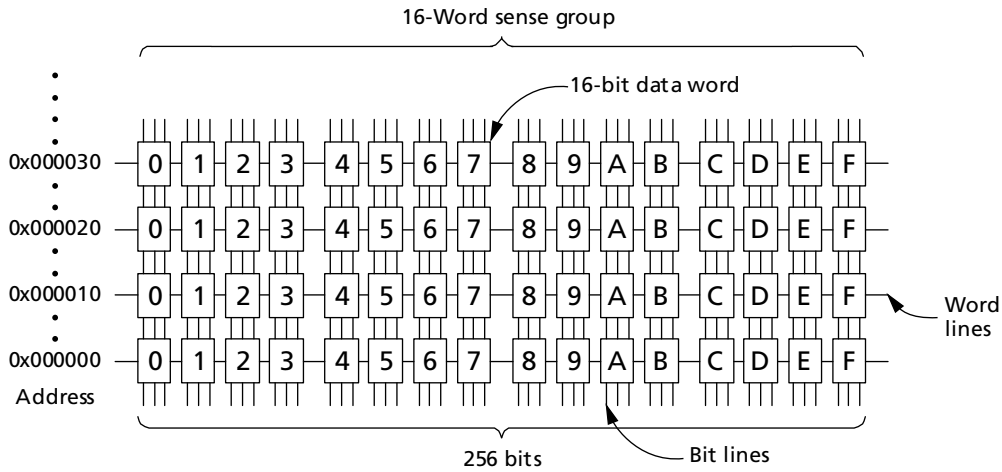
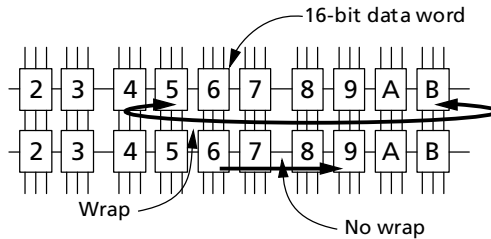

Figure 4: Wrap/No-Wrap Example



End-of-Wordline Delay

Output delays may occur when the burst sequence crosses the first end-of-wordline boundary onto the start of the next wordline.

No delays occur if the starting address is sense-group aligned or if the burst sequence never crosses a wordline boundary. However, if the starting address is not sense-group aligned, the worst-case end-of-wordline delay is one clock cycle less than the initial access latency count used. This delay occurs only once during the burst access. WAIT informs the system of this delay when it occurs.

Figure 5: End-of-Wordline Delay

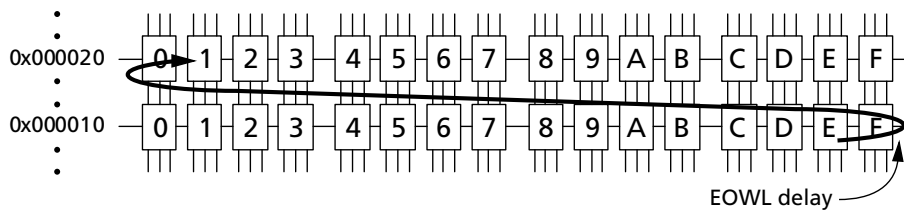

Write

CE# LOW and WE# LOW place the device in bus write mode, where RST# and OE# must be HIGH, CLK and ADV# are ignored, input data and address are sampled on the rising edge of WE# or CE#, whichever occurs first.

During a write operation in muxed devices, address is latched during the rising edge of ADV# OR CE# whichever occurs first and Data is latched during the rising edge of WE# OR CE# whichever occurs first.

Bus WRITE cycles are asynchronous only.

The following conditions apply when a bus WRITE cycle occurs immediately before, or immediately after, a bus READ cycle:

- When transitioning from a bus READ cycle to a bus WRITE cycle, CE# or ADV# must toggle after OE# goes HIGH.
- When in synchronous read mode (RCR15 = 0; burst clock running), bus WRITE cycle timings t_{VHWL} (ADV# HIGH to WE# LOW), t_{CHWL} (CLK HIGH to WE# LOW), and t_{WHCH} (WE# HIGH to CLK HIGH) must be met.
- When transitioning from a bus WRITE cycle to a bus READ cycle, CE# or ADV# must toggle after WE# goes HIGH.

Command Definitions

Commands are written to the device to control all operations. Some commands are two-cycle commands that use a SETUP and a CONFIRM command; other commands are single-cycle commands that use only a SETUP command followed by a data READ cycle or data WRITE cycle. Valid commands and their associated command codes are shown in the table below.

The device supports READ-While-WRITE and READ-While-ERASE operations with bus cycle granularity, not command granularity. That is, both bus WRITE cycles of a two-cycle command do not need to occur as back-to-back bus WRITE cycles to the device; READ cycles may occur between the two write WRITE cycles of a two-cycle command.

However, a WRITE operation must not occur between the two bus WRITE cycles of a two-cycle command; this will cause a command sequence error (SR[7,5,4] = 1).

Due to the large buffer size of devices, the system interrupt latency may be impacted during the buffer fill phase of a buffered programming operation. Please refer to the relevant Application Note to implement a software solution for your system

Figure 6: Two-Cycle Command Sequence

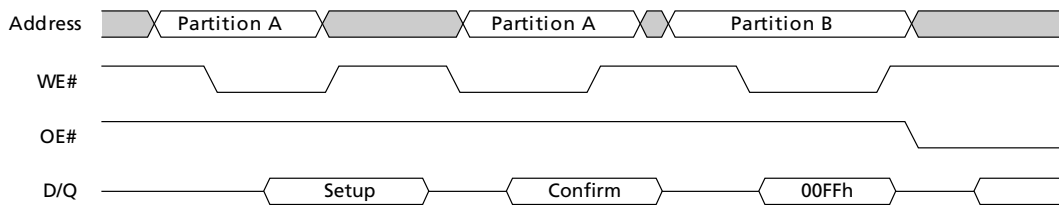

Figure 7: Single-Cycle Command Sequence

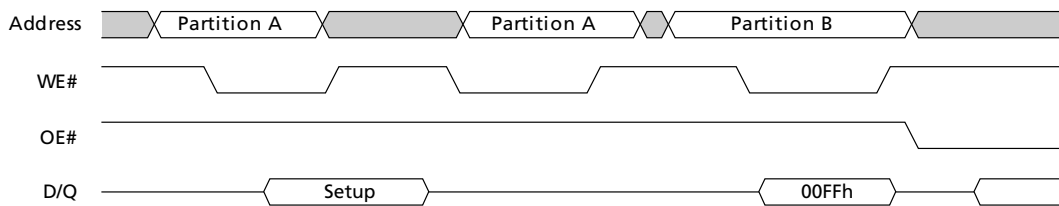

Figure 8: READ Cycle Between WRITE Cycles

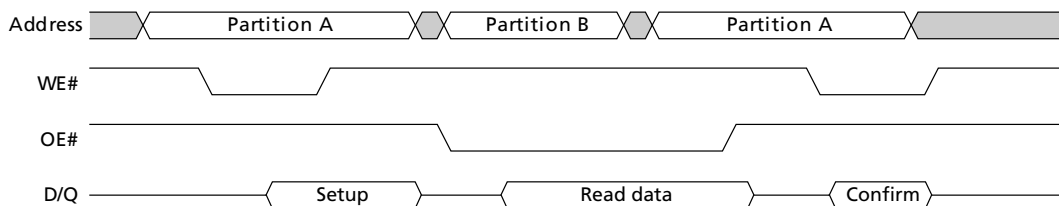

Figure 9: Illegal Command Sequence

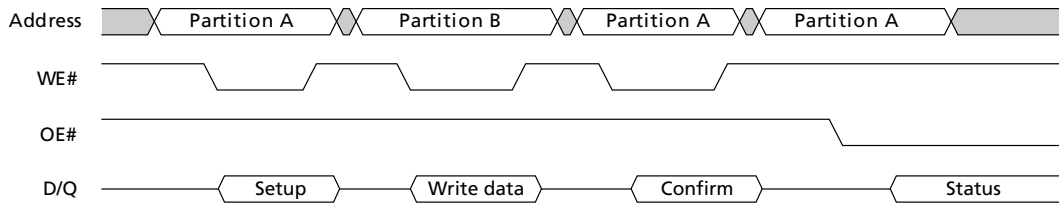

Table 7: Command Set

Command	Code (Setup/Confirm)	Description
Register Operations		
PROGRAM READ CONFIGURATION REGISTER	0060h/0003h	Programs the read configuration register. The desired read configuration register value is placed on the address bus, and written to the read configuration register when the CONFIRM command is issued.
PROGRAM EXTENDED CONFIGURATION REGISTER	0060h/0004h	Programs the extended configuration register. The desired extended configuration register value is placed on the address bus, and written to the read configuration register when the CONFIRM command is issued.
PROGRAM OTP AREA	00C0h	Programs OTP area and OTP lock registers. The desired register data is written to the addressed register on the next WRITE cycle.
CLEAR STATUS REGISTER	0050h	Clears all error bits in the status register.
Read Mode Operations		
READ ARRAY	00FFh	Places the addressed partition in read array mode. Subsequent reads outputs array data.
READ STATUS REGISTER	0070h	Places the addressed partition in read status mode. Subsequent reads outputs status register data.
READ ID	0090h	Places the addressed partition in read ID mode. Subsequent reads from specified address offsets output unique device information.
READ CFI	0098h	Places the addressed partition in read CFI mode. Subsequent reads from specified address offsets output CFI data.
Array Programming Operations		
SINGLE-WORD PROGRAM	0041h	Programs a single word into the array. Data is written to the array on the next WRITE cycle. The addressed partition automatically switches to read status register mode.
BUFFERED PROGRAM	00E9h/00D0h	Initiates and executes a BUFFERED PROGRAM operation. Additional bus READ/WRITE cycles are required between the and confirm commands to properly perform this operation. The addressed partition automatically switches to read status register mode.

Table 7: Command Set (Continued)

Command	Code (Setup/Confirm)	Description
BUFFERED ENHANCED FACTORY PROGRAM	0080h/00D0h	Initiates and executes a BUFFERED ENHANCED FACTORY PROGRAM operation. Additional bus READ/WRITE cycles are required after the CONFIRM command to properly perform this operation. The addressed partition automatically switches to read status register mode.
Block Erase Operations		
BLOCK ERASE	0020h/00D0h	Erases a single, addressed block. The ERASE operation commences when the CONFIRM command is issued. The addressed partition automatically switches to read status register mode.
Security Operations		
Lock Block	0060h/0001h	Sets the lock bit of the addressed block.
Unlock Block	0060h/00D0h	Clears the lock bit of the addressed block.
Lock-Down Block	0060h/002Fh	Sets the lock-down bit of the addressed block.
Other Operations		
SUSPEND	00B0h	Initiates a suspend of a PROGRAM or BLOCK ERASE operation already in progress when issued to any device address SR[6] = 1 indicates erase suspend SR[2] = 1 indicates program suspend
RESUME	00D0h	Resumes a suspended PROGRAM or BLOCK ERASE operation when issued to any device address. A program suspend nested within an erase suspend is resumed first.
BLANK CHECK	00BCh/00D0h	Performs a blank check of an addressed block. The addressed partition automatically switches to read status register mode.

Status Register

The status register is a 16-bit, read-only register that indicates device status, region status, and operating errors. Upon power-up or exit from reset, the status register defaults to 0080h (device ready, no errors).

The status register has status bits and error bits. Status bits are set and cleared by the device; error bits are only set by the device. Error bits are cleared using the CLEAR STATUS REGISTER command or by resetting the device.

To read from the status register, first issue the READ STATUS REGISTER command and then read from the device. Note that some commands automatically switch from read mode to read status register mode.

Table 8: Status Register Bit Definitions (Default Value = 0080h)

Bit	Name	Description
15:10	Reserved	Reserved for future use; these bits will always be set to zero
9:8	Partition program error	SR[9]/SR[8] 0 0 = Region program successful 1 0 = Region program error: Attempted write with object data to control mode region 0 1 = Region-program error: Attempted rewrite to object mode region 1 1 = Region-program error: Attempted write using illegal command (SR[4] will also be set along with SR[8,9] for the above error conditions)
7	Device status	0 = Device is busy; SR[9,8,6:1] are invalid, SR[0] is valid 1 = Device is ready; SR[9:8], SR[6:1] are valid
6	Erase suspend	0 = Erase suspend not in effect 1 = Erase suspend in effect
5:4	Erase error/blank check error program error (command sequence error)	SR[5]/SR[4] 0 0 = PROGRAM or ERASE operation successful 0 1 = Program error: operation aborted 1 0 = Erase error: Operation aborted; Blank check error: Operation failed 1 1 = Command sequence error: Command aborted
3	V _{PP} error	0 = V _{PP} within acceptable limits during program or erase 1 = V _{PP} < V _{PPLK} during program or erase; operation aborted
2	Program suspend	0 = Program suspend not in effect 1 = Program suspend in effect
1	Block lock error	0 = Block not locked during program or erase; operation successful 1 = Block locked during program or erase; operation aborted
0	Partition status	SR[7]/SR[0] 0 0 = Active PROGRAM or ERASE operation in addressed partition BEFP: Program or verify complete, or ready for data 0 1 = Active PROGRAM or ERASE operation in other partition BEFP: Program or Verify in progress 1 0 = No active PROGRAM or ERASE operation in any partition BEFP: Operation complete 1 1 = Reserved

Clear Status Register

The status register has status bits and error bits. Status bits are set and cleared by the device; error bits are only set by the device. Error bits are cleared using the CLEAR STATUS REGISTER command or by resetting the device.

Note: Care should be taken to avoid status register ambiguity. If a command sequence error occurs while in erase suspend, SR[5:4] will be set, indicating a command sequence error. When the ERASE operation is resumed (and finishes), any errors that may have occurred during the ERASE operation will be masked by the command sequence error. To avoid this situation, clear the status register prior to resuming any suspended ERASE operation.

The CLEAR STATUS REGISTER command functions independent of the voltage level on V_{pp} . Issuing the CLEAR STATUS REGISTER command places the addressed partition in read status register mode. Other partitions are not affected.

Table 9: CLEAR STATUS REGISTER Command Bus Cycles

Command	Setup WRITE Cycle Address Bus	Setup WRITE Cycle Data Bus	Confirm WRITE Cycle Address Bus	Confirm WRITE Cycle Data Bus
CLEAR STATUS REGISTER	Device address	0050h	–	–

Read Configuration Register

The read configuration register is a volatile, 16-bit read/write register used to select bus read modes and to configure synchronous burst read behavior of the device.

The read configuration register is programmed using the PROGRAM READ CONFIGURATION REGISTER command. To read the read configuration register, issue the READ ID command and then read from offset 0005h.

Upon power-up or exit from reset, the read configuration register defaults to asynchronous mode (RCR15 = 1; all other bits are ignored).

Table 10: Read Configuration Register Bit Definitions

Bit	Name	Description
15	Read mode	0 = Synchronous burst mode 1 = Asynchronous mode (default)
14:11	Latency count	0 0 1 1 = Code 3 0 1 0 0 = Code 4 0 1 0 1 = Code 5 0 1 1 0 = Code 6 0 1 1 1 = Code 7 1 0 0 0 = Code 8 1 0 0 1 = Code 9 1 0 1 0 = Code 10 1 0 1 1 = Code 11 1 1 0 0 = Code 12 1 1 0 1 = Code 13 Other bit settings are reserved; see the table below for supported clock frequencies
10	WAIT polarity	0 = WAIT signal is LOW-true 1 = WAIT signal is HIGH-true
9	Reserved	Write 0 to reserved bits
8	WAIT delay	0 = WAIT de-asserted with valid data 1 = WAIT de-asserted one clock cycle before valid data
7:3	Reserved	Write 0 to reserved bits
2:0	Burst length	0 1 0 = 8-word burst, wrap only 0 1 1 = 16-word burst, wrap only 1 1 1 = Continuous-burst: linear, no-wrap only Other bit settings are reserved

Table 11: Supported Clock Frequencies

Latency Count Code	Clock Frequency V _{CCQ} = 1.7V to 2.0V
3	≤32.6 MHz
4	≤43.5 MHz
5	≤54.3 MHz
6	≤65.2 MHz

Table 11: Supported Clock Frequencies (Continued)

Latency Count Code	Clock Frequency $V_{CCQ} = 1.7V \text{ to } 2.0V$
7	≤76.1 MHz
8	≤87.0 MHz
9	≤97.8 MHz
10	≤108.7 MHz
11	≤119.6 MHz
12	≤130.4 MHz
13	≤133.3 MHz

Programming the Read Configuration Register

The read configuration register is programmed by issuing the PROGRAM READ CONFIGURATION REGISTER command. The desired RCR[15:0] settings are placed on A[15:0], while the PROGRAM READ CONFIGURATION REGISTER SETUP command is placed on the data bus. Upon issuing the SETUP command, the read mode of the addressed partition is automatically changed to read status register mode.

Next, the CONFIRM command is placed on the data bus while the desired settings for RCR[15:0] are again placed on A[16:1]. Upon issuing the CONFIRM command, the read mode of the addressed partition is automatically switched to read array mode.

Because the desired read configuration register value is placed on the address bus, any hardware-connection offsets between the host's address outputs and the device's address inputs must be taken into account. For example, if the host's address outputs are aligned to the device's address inputs such that host address bit A1 is connected to address bit A0, the desired register value must be left-shifted by one (for example, 2532h << 4A64h) before programming the read configuration register.

Synchronous read accesses cannot occur until both the device and the host are in synchronous read mode. Therefore, the software instructions used to perform read configuration register programming and host chip select configuration must be guaranteed not to fetch from the device (instructions must be in system RAM or locked in cache). This also applies when switching back to asynchronous read mode from synchronous read mode.

Table 12: PROGRAM READ CONFIGURATION REGISTER Bus Cycles

Command	Setup WRITE Cycle Address Bus	Setup WRITE Cycle Data Bus	Confirm WRITE Cycle Address Bus	Confirm WRITE Cycle Data Bus
PROGRAM READ CONFIGURATION REGISTER	RCR settings	0060h	RCR settings	0003h

Extended Configuration Register

The extended configuration register is a volatile 16-bit, read/write register used to select deep-power down and output-driver strength of the device.

Upon power-up or exit from reset, the extended configuration register defaults to 0004h.

The extended configuration register is programmed using the PROGRAM EXTENDED CONFIGURATION REGISTER command. To read the extended configuration register, issue the READ ID command to a partition, and read from <partition base address> + 06h.

Table 13: Extended Configuration Register Bit Definitions (Default Value = 0004h)

Bit	Name	Description
15:3	Reserved	Write 0 to reserved bits
2:0	Output driver control	0 0 1 = Code 1 0 1 0 = Code 2 0 1 1 = Code 3 1 0 0 = Code 4 (default) 1 0 1 = Code 5 1 1 0 = Code 6 Other bit settings are reserved

Output Driver Control

The output driver control bits of the extended configuration register enable adjustment of the device's output-driver strength for DQ[15:0] and WAIT. Upon power-up or reset, ECR[2:0] defaults to 100b for to an output impedance setting of 30 Ohms. To change the output-driver strength, program ECR[2:0] to the desired setting.

Table 14: Output Driver Control Characteristics

ECR[2:0]	Driver Impedance (at $V_{CCQ}/2$)	Driver Multiplier	Load (Same Speed)
0 0 1	90 Ohms	1/3	10pF
0 1 0	60 Ohms	1/2	15pF
0 1 1	45 Ohms	2/3	20pF
1 0 0	30 Ohms	1	30pF
1 0 1	20 Ohms	1-1/2	35pF
1 1 0	15 Ohms	2	40pF

Programming the Extended Configuration Register

The extended configuration register is programmed by issuing the PROGRAM EXTENDED CONFIGURATION REGISTER command. The desired ECR[15:0] settings are placed on A[15:0], while the PROGRAM EXTENDED CONFIGURATION REGISTER SETUP command is placed on the data bus. Upon issuing the SETUP command, the read mode of the addressed partition is automatically changed to read status register mode.

Next, the CONFIRM command is placed on the data bus while the desired settings for ECR[15:0] are again placed on A[15:0]. Upon issuing the CONFIRM command, the read mode of the addressed partition is automatically switched to read array mode.

Because the desired ECR value is placed on the address bus, any hardware-connection offsets between the host's address outputs and the device's address inputs must be taken into account.

For example, if the host's address outputs are aligned to the device's address inputs such that host address bit A1 is connected to address bit A0, the desired register value must be left-shifted by one (for example, 2532h << 4A64h) before programming the ECR.

Programming the ECR functions independently of the voltage on V_{PP}.

Table 15: Program Extended Configuration Register Command Bus Cycles

Command	Setup WRITE Cycle Address Bus	Setup WRITE Cycle Data Bus	Confirm WRITE Cycle Address Bus	Confirm WRITE Cycle Data Bus
PROGRAM EXTENDED CONFIGURATION REGISTER	Register Data	0060h	Register Data	0004h

Read Operations

The following types of data can be read from the device: array data (read array), device information (read ID), CFI data (read CFI), and device status (read status register).

Upon power-up or return from reset, the device defaults to read array mode. To change the read mode, the appropriate command must be issued to the device.

The table below shows the command codes used to configure the device for the desired read mode.

Table 16: READ MODE Command Bus Cycles

Command	Setup WRITE Cycle Address Bus	Setup WRITE Cycle Data Bus	Confirm WRITE Cycle Address Bus	Confirm WRITE Cycle Data Bus
READ ARRAY	Partition address	00FFh	–	–
READ STATUS REGISTER	Partition address	0070h	–	–
READ ID	Partition address	0090h	–	–
READ CFI	Partition address	0098h	–	–

Read Array

Upon power-up or exit from reset, the device defaults to read array mode. Issuing the READ ARRAY command places the addressed partition in read array mode and can only be issued to a partition that is not actively programming or erasing. Subsequent reads output array data from that partition.

The addressed partition remains in read array mode until a different READ command is issued, a PROGRAM or ERASE operation is performed, or a BLOCK LOCK SETUP command is issued in that partition, in which case the read mode automatically changes to read status.

To change a partition that is actively programming or erasing to read array mode, first issue the SUSPEND command. After the operation has been suspended, issue the READ ARRAY command to the partition. When the PROGRAM or ERASE operation is subsequently resumed, the partition will automatically revert back to read status mode.

The READ ARRAY command functions independently of the voltage level on V_{pp} .

Issuing the READ ARRAY command to a partition that is actively programming or erasing causes subsequent reads from that partition to output invalid data. Valid array data is output only after the PROGRAM or ERASE operation has completed.

Read ID

Issuing the READ ID command places the addressed partition in read ID mode. Subsequent reads output device information such as manufacturer code, device identifier code, block lock status, OTP data, or read configuration register data.

The addressed partition remains in read ID mode until a different READ command is issued, or a PROGRAM or ERASE operation is performed in that partition, in which case the read mode automatically changes to read status.

The READ ID command functions independently of the voltage level on V_{pp} .

Issuing the READ ID command to a partition that is actively programming or erasing changes that partition's read mode to read ID mode. Subsequent reads from that partition will not output device information until the PROGRAM or ERASE operation has completed.

Table 17: Device Information

Device Information	Address Bus	Data Bus
Device manufacturer code	Partition base address + 00h	0089h
Device ID code	Partition base address + 01h	Device ID
Block lock status	Block base address + 02h	D0 = Lock status D1 = Lock-down status
Read configuration register	Partition base address + 05h	Configuration register data
Extended configuration register	Partition base address + 06h	Extended configuration register data
OTP lock register 0	Partition base address + 80h	Lock register 0 data
OTP block 0 – factory segment	Partition base address + 81h to 84h	Factory-programmed data
OTP block 1 – user-programmable segment	Partition base address + 85h to 88h	User data
OTP lock register 1	Partition base address + 89h	Lock register 1 data
OTP blocks 2–17	Partition base address + 8Ah to 109h	User data

Read CFI

Issuing the READ CFI command places the addressed partition in read CFI mode. Subsequent reads from that partition output CFI information.

The addressed partition remains in read CFI mode until a different READ command is issued, or a PROGRAM or ERASE operation is performed, or a BLOCK LOCK SETUP command is issued, which changes the read mode to read status register mode.

The READ CFI command functions independently of the voltage level on V_{PP} .

Issuing the READ CFI command to a partition that is actively programming or erasing changes that partition's read mode to read CFI mode. Subsequent reads from that partition will return invalid data until the PROGRAM or ERASE operation has completed.

Read Status Register

Issuing the READ STATUS REGISTER command places the addressed partition in read status register mode; other partitions are not affected. Subsequent reads from that partition output status register information.

Note: Chip enable or output enable must be toggled to update the status register data.

The addressed partition remains in read status register mode until a different READ MODE command is issued to that partition. Performing a PROGRAM, ERASE, or BLOCK LOCK operation also changes the partition's read mode to read status register mode.

The READ STATUS REGISTER command functions independently of the voltage level on V_{PP} .

Status register contents are valid only when SR[7]=1.

WAIT Operation

WAIT indicates the validity of output data during synchronous READ operations. It is asserted when output data is invalid and de-asserted when output data is valid. WAIT changes state only on valid clock edges. Upon power-up or exit from reset, WAIT defaults to LOW true (RCR[10] = 0).

WAIT is de-asserted during asynchronous reads. During WRITE operations, WAIT is High-Z on non-mux devices, and deasserted on AD-mux devices.

Table 18: WAIT Behavior Summary – Non-MUX

Device Operation	CE#	OE#	WE#	WAIT
Standby (Device not selected)	HIGH	X	X	High-Z
Output Disable	LOW	HIGH	HIGH	High-Z
Synchronous Read	LOW	LOW	HIGH	Active WAIT asserted = invalid data WAIT de-asserted = valid data
Asynchronous Read	LOW	LOW	HIGH	De-asserted
Write	LOW	HIGH	LOW	High-Z

Note: 1. This table does not apply to AADM devices. See AADM Mode for WAIT behavior in AADM mode.

Table 19: WAIT Behavior Summary – AD MUX

Device Operation	CE#	OE#	WE#	WAIT
Standby (Device not selected)	HIGH	X	X	High-Z
Output Disable	LOW	HIGH	HIGH	De-asserted
Synchronous Read	LOW	LOW	HIGH	Active WAIT asserted = invalid data WAIT de-asserted = valid data
Asynchronous Read	LOW	LOW	HIGH	De-asserted
Write	LOW	HIGH	LOW	De-asserted

Note: 1. This table does not apply to AADM devices. See AADM Mode for WAIT behavior in AADM mode.

Programming Modes

Each programming region in a block can be configured for either control mode or object mode.

The programming mode is automatically set based on the data pattern when a region is first programmed. Selecting either control mode or object mode is done according to the specific needs of the system. In control mode, code or data is frequently changed (such as the flash file system or header information). In object mode, large code or data (such as objects or payloads) is infrequently changed. By implementing the appropriate programming mode, software can efficiently organize how information is stored in the memory array.

Control mode programming regions and object mode programming regions can be intermingled within the same erase block. However, the programming mode of any region within a block can be changed only after erasing the entire block.

Control Mode

Control mode programming is invoked when only the A-half ($A3 = 0$) of the programming region is programmed to 0s. The B-half ($A3 = 1$) remains erased. Control mode allows up to 512 bytes of data to be programmed in the region. The information can be programmed in bits, bytes, or words.

Control mode supports the following programming methods:

- Single-word programming (0041h)
- Buffered programming (00E9h/00D0h)
- Buffered enhanced factory programming (0080h/00D0h)

When buffered programming is used in control mode, all addresses must be in the A-half of the buffer ($A3 = 0$). During buffer fill, the B-half ($A3 = 1$) addresses do not need to be filled with 0xFFFF.

Control mode programming is useful for storing dynamic information, such as flash file system headers, file Info, and so on. Typically, control mode programming does not require the entire 512 bytes of data to be programmed at once. It may also contain data that is changed after initial programming using a technique known as “bit twiddling”. Header information can be augmented later with additional new information within a control-mode-programmed region. This allows implementation of legacy file systems, as well as transaction-based power-loss recovery.

In a control mode region, PROGRAM operations can be performed multiple times. However, care must be taken to avoid programming any zeros in the B-half ($A3 = 1$) of the region. Violation of this usage will cause SR[4] and SR[9] to be set, and the PROGRAM operation will be aborted.

Figure 10: Configurable Programming Regions: Control Mode and Object Mode

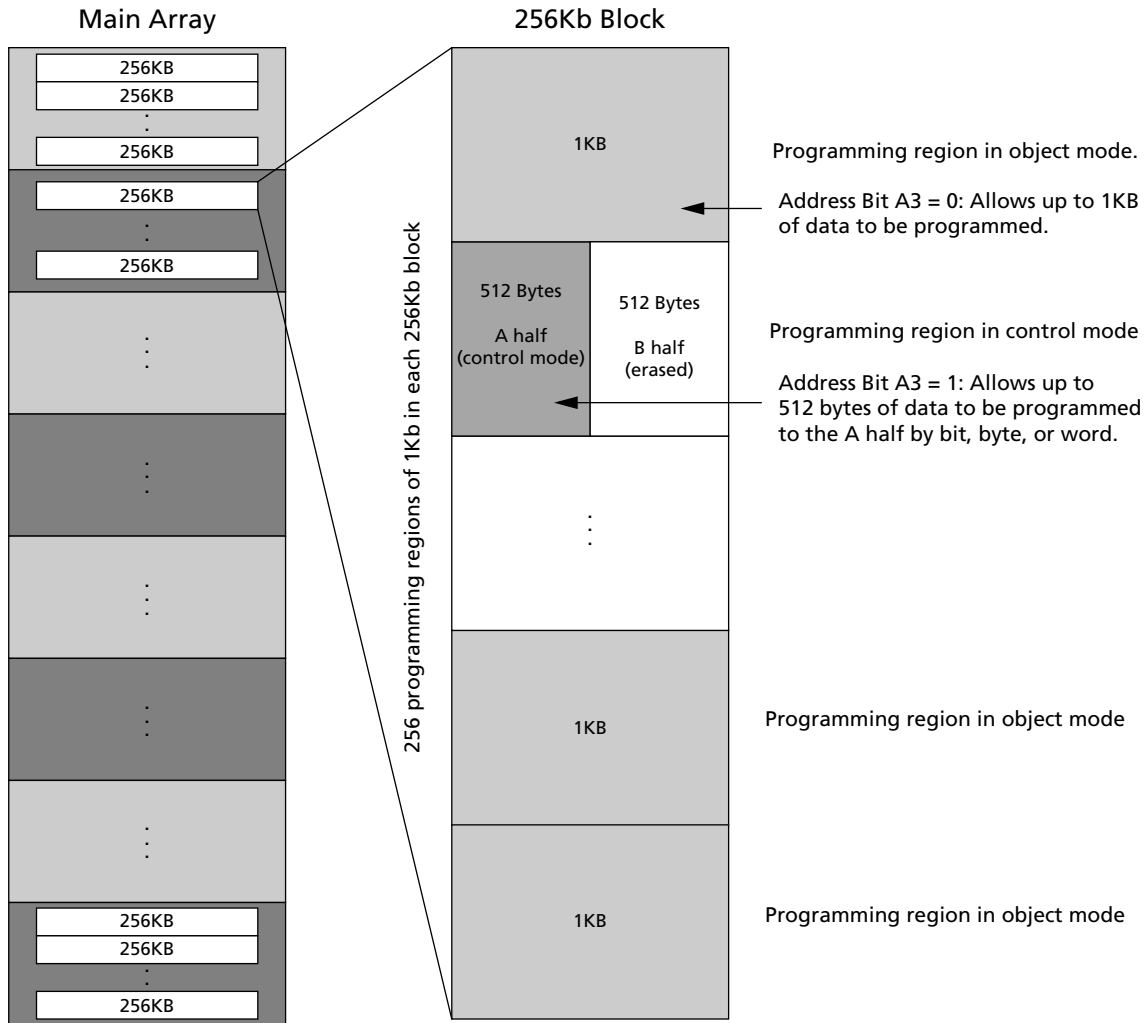

Object Mode

Object mode programming is invoked when one or more bits are programmed to zero in the B-half of the programming region (A3 = 1).

Object mode allows up to 1KB to be stored in a programming region. Multiple regions are used to store more than 1KB of information. If the object is less than 1KB, the unused content will remain as 0xFFFF (erased).

Object mode supports the following programming methods:

- Buffered programming (00E9h/00D0h)
- Buffered enhanced factory programming (0080h/00D0h)

Single-word programming (0041h) is not supported in object mode. To perform multiple PROGRAM operations within a programming region, control mode must be used.

(Object mode is useful for storing static information, such as objects or payloads, that rarely change.)

Once the programming region is configured in object mode, it cannot be augmented or overwritten without first erasing the entire block containing the region. Subsequent PROGRAM operations to a programming region configured in object mode will cause SR[4] and SR[8] to be set and the PROGRAM operation to be aborted.

Issuing the 41h command to the B-half of an erased region will set error bits SR[8] and SR[9], and the PROGRAM operation will not proceed.

Figure 11: Configurable Programming Regions: Control Mode and Object Mode Segments

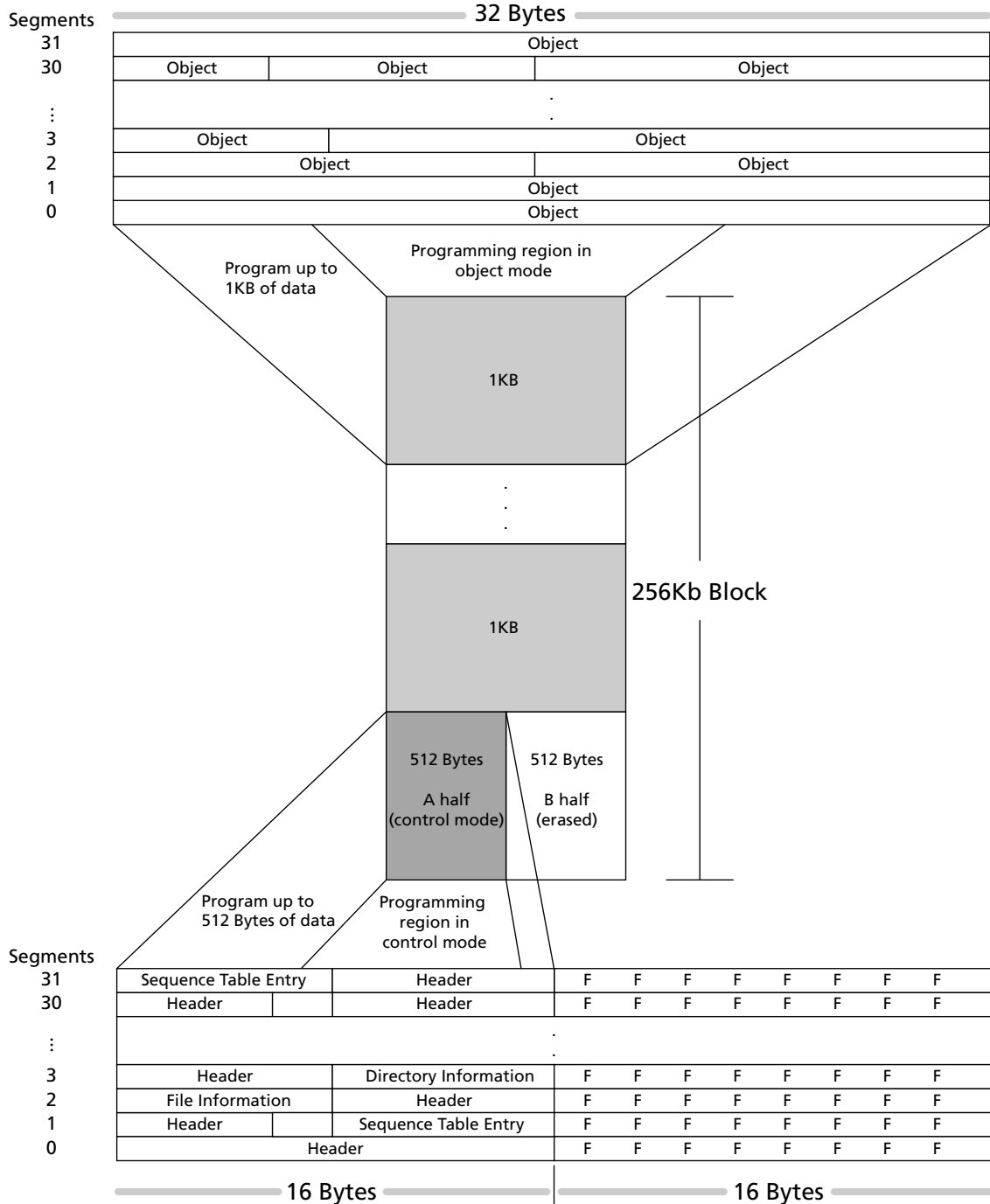

Table 20: Programming Region Next State

Command Issued	Current State of Programming Region		
	Erased	Control Mode	Object Mode
0041h to B-half (A3 = 1)	Program fail; Illegal command SR[4,8,9] = 1	Program fail; Illegal command SR[4,8,9] = 1	Program fail; Illegal command SR[4,8,9] = 1
0041h to A-half (A3 = 0)	Program successful SR[4,8,9] = 0 Region configured to control mode	Program successful SR[4,8,9] = 0	Program fail; Rewrite to object mode region SR[4,8] = 1 SR[9] = 0
00E9h to B-half (A3 = 1)	Program successful SR[4,8,9] = 0 Region configured to object mode	Program fail; Object data to control mode region SR[4,9] = 1 SR[8] = 0	Program fail; Rewrite to object mode region SR[4,8] = 1 SR[9] = 0
00E9h to A-half (A3 = 0)	Program successful SR[4,8,9] = 0 Region configured to control mode	Program successful SR[4,8,9] = 0	Program fail; Rewrite to object mode region SR[4,8] = 1 SR[9] = 0

Program Operations

Programming the array changes 1s to 0s. To change 0s to 1s, an ERASE operation must be performed. Only one PROGRAM operation can occur at a time. Programming is permitted during erase suspend.

Information is programmed into the array by issuing the appropriate command.

All PROGRAM operations require the addressed block to be unlocked and a valid V_{PP} voltage applied throughout the PROGRAM operation. Otherwise, the PROGRAM operation will abort, setting the appropriate status register error bit(s).

If the device is deselected during a PROGRAM or ERASE operation, the device continues to consume active power until the PROGRAM or ERASE operation has completed.

Table 21: PROGRAM Command Bus Cycles

Command	Setup WRITE Cycle Address Bus	Setup WRITE Cycle Data Bus	Confirm WRITE Cycle Address Bus	Confirm WRITE Cycle Data Bus
SINGLE-WORD PROGRAM	Device address	0041h	Device address	Array data
BUFFERED PROGRAM	Device address	00E9h	Device address	00D0h
BUFFERED ENHANCED FACTORY PROGRAM	Device address	0080h	Device address	00D0h

Single-Word Programming

Single-word programming is performed by issuing the SINGLE-WORD PROGRAM command. This is followed by writing the desired data at the desired address. The read mode of the addressed partition is automatically changed to read status register mode, which remains in effect until another READ MODE command is issued.

Issuing the READ STATUS REGISTER command to another partition switches that partition's read mode to read status register mode, thereby allowing programming progress to be monitored from that partition's address.

Single-Word Programming is supported in control mode only. The array address specified must be in the A-half of the programming region.

During programming, the status register indicates a busy status ($SR[7] = 0$). Upon completion, the status register indicates a ready status ($SR[7] = 1$). The status register should be checked for any errors, then cleared.

The only valid commands during programming are READ ARRAY, READ ID, READ CFI, and PROGRAM SUSPEND. After programming completes, any valid command can be issued.

Issuing the READ ARRAY, READ ID, or READ CFI command to a partition that is actively programming causes subsequent reads from that partition to output invalid data. Valid data is output only after the PROGRAM operation is complete.

Standby power levels are not realized until the PROGRAM operation has completed. Asserting RST# immediately aborts the PROGRAM operation, and array contents at the addressed location are indeterminate. The addressed block should be erased and the data reprogrammed.

Buffered Programming

Buffered programming programs multiple words simultaneously into the memory array. Data is first written to a programming buffer and then programmed into the array in buffer-sized increments, significantly reducing the effective word programming time.

Optimal performance and power consumption is realized only by aligning the starting address to buffer-sized boundaries within the array. Crossing a buffer-sized boundary can cause the buffered programming time to double.

The BUFFERED PROGRAM operation consists of the following fixed, predefined sequence of bus WRITE cycles: 1) Issue the SETUP command; 2) Issue a word count; 3) Fill the buffer with user data; and 4) Issue the CONFIRM command. Once the SETUP command has been issued to an address, subsequent bus WRITE cycles must use addresses within the same block throughout the operation; otherwise, the operation will abort. Bus READ cycles are allowed at any time and at any address.

Note: V_{PP} must be at V_{PPL} or V_{PPH} throughout the BUFFERED PROGRAM operation.

Upon programming completion, the status register indicates ready ($SR7 = 1$), and any valid command may be issued. A full status register check should be performed to check for any programming errors. If any error bits are set, the status register should be cleared using the CLEAR STATUS REGISTER command.

A subsequent BUFFERED PROGRAM operation can be initiated by issuing another SETUP command and repeating the buffered programming sequence. Any errors in the status register caused by a previous operation should first be cleared to prevent masking of errors that may occur during a subsequent BUFFERED PROGRAM operation.

Valid commands issued to the busy partition during array programming are READ ARRAY, READ ID, READ CFI, READ STATUS, and PROGRAM SUSPEND.

Issuing the READ ARRAY, READ ID, or READ CFI command to a partition that is actively programming causes subsequent reads from that partition to output invalid data. Valid data is output only after the PROGRAM operation has completed.

Buffered Enhanced Factory Programming

Buffered enhanced factory programming (BEFP) improves programming performance through the use of the write buffer, elevated programming voltage (V_{PPH}), and enhanced programming algorithm. User data is written into the write buffer, and then the buffer contents are automatically written into the array in buffer-sized increments.

Internal verification during programming (inherent to MLC technology) and status register error checking are used to determine proper completion of the PROGRAM operation. This eliminates delays incurred when switching between SINGLE-WORD PROGRAM and VERIFY operations.

BEFP consists of the following three distinct phases:

1. Setup phase: V_{PPH} and block lock checks
2. Program/verify phase: buffered programming and verification
3. Exit phase: block error check

BEFP is supported in both control mode and object mode. The programming mode selection for the entire array block is driven by the specific type of information, such as header or object data. Header/object data is aligned on a 1KB programming region boundary in the main array block.

Table 22: BEFP Requirements and Considerations

BEFP Requirements	Temperature (T_{CASE}) must be 25 °C, \pm 5 °C
	Voltage on VCC must be within the allowable operating range
	Voltage on VPP must be within the allowable operating range
	Block being programmed must be erased and unlocked
BEFP Considerations	Block cycling below 100 erase cycles
	Reading from another partition during EFP (RWW) is not allowed
	BEFP programs within one block at a time
	BEFP cannot be suspended

BEFP Setup Phase

Issuing the BEFP SETUP and CONFIRM command sequence starts the BEFP algorithm. The read mode of the addressed partition is automatically changed to read status register mode.

The address used when issuing the SETUP and CONFIRM commands must be buffer-size aligned within the block being programmed; buffer contents cannot cross block boundaries.

Note: The READ STATUS REGISTER command must not be issued; it will be interpreted as data to be written to the write buffer.

A setup delay ($t_{BEFP/setup}$) occurs while the internal algorithm checks V_{PP} and block lock status. If errors are detected, the appropriate status register error bits are set and the operation aborts.

The status register should be polled for successful BEFP setup, indicated by $SR[7:0] = 0$ (device busy, buffer ready for data).

BEFP Program/Verify Phase

Data is first written into the write buffer, then programmed into the array. During the buffer fill sequence, the address used must be buffer-size aligned. Use of any other address will cause the operation to abort with a program fail error, and any data previously loaded in the buffer will not be programmed into the array.

The buffer fill data is stored in sequential buffer locations starting at address 00h. A word count equal to the maximum buffer size is used; therefore, the buffer must be completely filled. If the amount of data is less than the maximum buffer size, the remaining buffer locations must be padded with FFFFh to completely fill the buffer.

Array programming starts as soon as the write buffer is full. Data words from the write buffer are programmed into sequential array locations. $SR0 = 1$ indicates the write buffer is not available while the BEFP algorithm programs the array.

The status register should be polled for $SR0 = 0$ (buffer ready for data) to determine when the array programming has completed and the write buffer is again available for loading. The internal address is automatically incremented to enable subsequent array programming to continue from where the previous buffer-fill/array program sequence ended within the block. This cycle can be repeated to program the entire block.

BEFP Exit Phase

To exit the program/verify phase, write FFFFh to an address outside of the block.



128Mb, 256Mb, 512Mb, 1Gb StrataFlash Memory Program Operations

The status register should be polled for SR7 = 1 (device ready), indicating the BEFP algorithm has finished running and the device has returned to normal operation.

A full status register error check should be performed to ensure the block was programmed successfully.

Erase Operations

BLOCK ERASE

Erasing a block changes 0s to 1s. To change 1s to 0s, a PROGRAM operation must be performed. Erasing is performed on a block basis; an entire block is erased each time an erase command sequence is issued. Once a block is fully erased, all addressable locations within that block read as logical 1s (FFFFh).

Only one BLOCK ERASE operation can occur at a time. A BLOCK ERASE operation is not permitted during program suspend. All BLOCK ERASE operations require the addressed block to be unlocked, and V_{PP} must be at V_{PPL} or V_{PPH} throughout the BLOCK ERASE operation. Otherwise, the operation aborts, setting the appropriate status register error bit(s).

To perform a BLOCK ERASE operation, issue the BLOCK ERASE SETUP command at the desired block address. The read mode of the addressed partition automatically changes to read status register mode and remains in effect until another READ MODE command is issued.

The ERASE CONFIRM command latches the address of the block to be erased. The addressed block is preconditioned (programmed to all 0s), erased, and then verified.

Issuing the READ STATUS REGISTER command to another partition switches that partition's read mode to the read status register, thereby allowing block erase progress to be monitored from that partition's address. SR0 indicates whether the addressed partition or the other partition is erasing.

During a BLOCK ERASE operation, the status register indicates a busy status (SR[7] = 0).

Issuing the READ ARRAY command to a partition that is actively erasing a main block causes subsequent reads from that partition to output invalid data. Valid array data is output only after the BLOCK ERASE operation has finished.

Upon completion, the status register indicates a ready status (SR[7] = 1). The status register should be checked for any errors, and then cleared.

If the device is deselected during an ERASE operation, the device continues to consume active power until the ERASE operation is completed.

Asserting RST# immediately aborts the BLOCK ERASE operation, and array contents at the addressed location are indeterminate. The addressed block should be erased again.

The only valid commands during a BLOCK ERASE operation are READ ARRAY, READ ID, READ CFI, and ERASE SUSPEND. After the BLOCK ERASE operation has completed, any valid command can be issued.

Table 23: ERASE Command Bus Cycle

Command	Setup WRITE Cycle Address Bus	Setup WRITE Cycle Data Bus	Confirm WRITE Cycle Address Bus	Confirm WRITE Cycle Data Bus
BLOCK ERASE	Device address	0020h	Block address	00D0h

SUSPEND and RESUME Operations

PROGRAM and ERASE operations of the main array can be suspended to perform other device operations, and then subsequently resumed. OTP area programming operations cannot be suspended. During erase suspend or program suspend, the addressed block must remain unlocked, V_{PP} must be at V_{PPL} or V_{PPH} , and $WP\#$ must remain unchanged. Otherwise, the ERASE or PROGRAM operation will abort, setting the appropriate status register error bit(s).

SUSPEND Operation

To suspend an ongoing ERASE or PROGRAM operation, issue the SUSPEND command to any device address. Issuing the SUSPEND command does not change the read mode.

Upon issuing a SUSPEND command, the ongoing ERASE or PROGRAM operation suspends after a delay of t_{SUSP} . The operation is suspended only when $SR[7:6] = 1$ (erase suspend) or $SR[7:2] = 1$ (program suspend).

While suspended, reading from a block that was being erased or programmed is not allowed. Also, programming within an erase suspended block is not allowed, and if attempted, will result in a programming error ($SR[4] = 1$). Erasing under program suspend is not allowed. However, array programming under erase suspend is allowed, and can also be suspended. This results in a simultaneous erase suspend and program suspend condition, indicated by $SR[7:6,2] = 1$. Additional valid commands while suspended are READ ARRAY, READ STATUS REGISTER, READ ID, READ CFI, CLEAR STATUS REGISTER, and RESUME. No other commands are allowed.

During suspend, $CE\#$ may be de-asserted, placing the device in standby and reducing active current to standby levels. V_{PP} must remain at V_{PPL} or V_{PPH} , and $WP\#$ must remain unchanged.

Asserting $RST\#$ aborts any suspended BLOCK ERASE and PROGRAM operations; array contents at the addressed locations will be indeterminate.

During suspend, $CE\#$ may be de-asserted. The device is placed in standby, reducing active current. V_{PP} must remain at V_{PPL} or V_{PPH} , and $WP\#$ must remain unchanged.

Asserting $RST\#$ aborts suspended BLOCK ERASE and PROGRAM operations; array contents at the addressed locations are indeterminate.

Table 24: Valid Commands During Suspend

Device Command	Program Suspend	Erase Suspend
Read Array	Allowed	Allowed
Read Status Register	Allowed	Allowed
Clear Status Register	Allowed	Allowed
Read Device Information	Allowed	Allowed
CFI Query	Allowed	Allowed
Word Program	Not Allowed	Allowed
Buffered Program	Not Allowed	Not Allowed
Buffered Enhanced Factory Program	Not Allowed	Not Allowed
Block Erase	Not Allowed	Not Allowed

Table 24: Valid Commands During Suspend (Continued)

Device Command	Program Suspend	Erase Suspend
Program/Erase Suspend	Not Allowed	Not Allowed
Program/Erase Resume	Allowed	Allowed

RESUME Operation

To resume a suspended ERASE or PROGRAM operation, issue the RESUME command to any device address. The ERASE or PROGRAM operation continues where it left off, and the respective status register suspend bit is cleared. Issuing the RESUME command does not change the read mode.

When the RESUME command is issued during a simultaneous erase suspend or program suspend condition, the PROGRAM operation is resumed first. Upon completion of the PROGRAM operation, the status register should be checked for any errors, and cleared if needed. The RESUME command must be issued again to complete the ERASE operation. Upon completion of the ERASE operation, the status register should be checked for any errors, and cleared if needed.

Table 25: SUSPEND and RESUME Command Bus Cycles

Command	Setup WRITE Cycle Address Bus	Setup WRITE Cycle Data Bus	Confirm WRITE Cycle Address Bus	Confirm WRITE Cycle Data Bus
SUSPEND	Device address	00B0h	–	–
RESUME	Device address	00D0h	–	–

BLANK CHECK Operation

Blank check verifies whether a main-array block is completely erased. A BLANK CHECK operation is performed one block at a time, and cannot be used during program suspend or erase suspend.

To use blank check, first issue the BLANK CHECK SETUP command followed by the CONFIRM command. The read mode of the addressed partition is automatically changed to read status register mode, which remains in effect until another read mode is issued.

During a BLANK CHECK operation, the status register indicates a busy status (SR[7] = 0). Upon completion, the status register indicates a ready status (SR[7] = 1). Issuing the READ STATUS REGISTER command to another partition switches that partition's read mode to read status register mode, thereby allowing the BLANK CHECK operation to be monitored from that partition's address.

The status register should be checked for any errors, and then cleared. If the BLANK CHECK operation fails (the block is not completely erased), then the status register will indicate a blank check error (SR[7:5] = 1).

The only valid command during a BLANK CHECK operation is read status. Blank check cannot be suspended. After the BLANK CHECK operation has completed, any valid command can be issued.

Table 26: BLANK CHECK Command Bus Cycles

Command	Setup WRITE Cycle Address Bus	Setup WRITE Cycle Data Bus	Confirm WRITE Cycle Address Bus	Confirm WRITE Cycle Data Bus
BLANK CHECK	Block address	00BCh	Block address	00D0h

Block Lock

Two methods of block lock control are available: software and hardware. Software control uses the BLOCK LOCK and BLOCK UNLOCK commands. Hardware control uses the BLOCK LOCK-DOWN command along with asserting WP#.

Upon power-up or exit from reset, all main array blocks are locked, but not locked down. Locked blocks cannot be erased or programmed. BLOCK LOCK and UNLOCK operations are independent of the voltage level on V_{pp}.

To lock, unlock, or lock-down a block, first issue the SETUP command to any address within the desired block. The read mode of the addressed partition is automatically changed to read status register mode. Next, issue the desired CONFIRM command to the block's address. Note that the CONFIRM command determines the operation performed. The status register should be checked for any errors, and then cleared.

The lock status of a block can be determined by issuing the READ ID command, and then reading from the block's base address + 02h. See the table below table for the lock-bit settings.

Blocks cannot be locked or unlocked while being actively programmed or erased. Blocks can be locked or unlocked during erase suspend, but not during program suspend. If a BLOCK ERASE operation is suspended, and then the block is locked or locked down, the lock status of the block will be changed immediately. When resumed, the ERASE operation will still complete.

Block lock-down protection is dependent on WP#. A locked-down block can only be unlocked by issuing the BLOCK UNLOCK command with WP# de-asserted. To return an unlocked block to the locked-down state, a BLOCK LOCK-DOWN command must be issued prior to asserting WP#.

When WP# = V_{IL}, blocks locked down are locked, and cannot be unlocked using the BLOCK UNLOCK command.

When WP# = V_{IH}, block lock-down protection is disabled; locked-down blocks can be individually unlocked using the BLOCK UNLOCK command.

Subsequently, when WP# = V_{IL}, previously locked-down blocks are once again locked and locked-down, including locked-down blocks that may have been unlocked while WP# was de-asserted.

Issuing the BLOCK LOCK-DOWN command to an unlocked block does not lock the block. However, asserting WP# after issuing the BLOCK LOCK-DOWN command locks (and locks down) the block. Lock-down for all blocks is only cleared upon power-up or exit from reset.

Table 27: BLOCK LOCK Command Bus Cycles

Command	Setup WRITE Cycle Address Bus	Setup WRITE Cycle Data Bus	Confirm WRITE Cycle Address Bus	Confirm WRITE Cycle Data Bus
BLOCK LOCK	Block address	0060h	Block address	0001h
BLOCK UNLOCK	Block address	0060h	Block address	00D0h

Table 27: BLOCK LOCK Command Bus Cycles (Continued)

Command	Setup WRITE Cycle Address Bus	Setup WRITE Cycle Data Bus	Confirm WRITE Cycle Address Bus	Confirm WRITE Cycle Data Bus
BLOCK LOCK-DOWN	Block address	0060h	Block address	002Fh

Table 28: Block Lock Configuration

Block Lock Configuration	Block Base Address	Bit
Block is unlocked	Block base address = 0x02	DQ0 = 0b0
Block is locked	Block base address = 0x02	DQ0 = 0b1
Block is not locked down	Block base address = 0x02	DQ1 = 0b0
Block is locked down	Block base address = 0x02	DQ1 = 0b1

Figure 12: BLOCK LOCK Operations

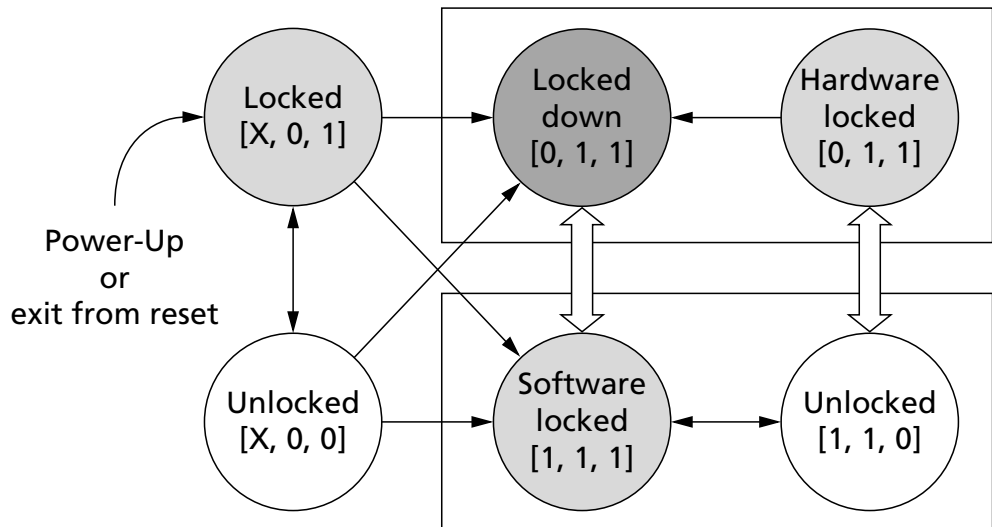

↔ Software control (LOCK, UNLOCK, LOCK-DOWN command)

⇔ Hardware control (WP#)

- Notes:
1. The [n,n,n] denotes logical state of WP#, DQ1, and DQ0, respectively; X = "Don't Care."
 2. The [0,1,1] states should be tracked by system software to differentiate between the hardware-locked state and the lock-down state.

One-Time Programmable Operations

The device contains sixteen 128-bit one-time programmable (OTP) blocks, two 64-bit OTP blocks, and two 16-bit OTP lock registers. OTP lock register 0 is used for locking OTP blocks 0 and 1 (two 64-bit blocks), and OTP lock register 1 is used for locking OTP blocks 2 through 17 (sixteen 128-bit blocks).

Each block contains OTP bits that are factory set to 1 and can only be programmed from 1 to 0; OTP block bits cannot be erased from 0 back to 1. This feature makes the OTP blocks particularly useful for implementing system-level security schemes, permanently storing data, or storing fixed system parameters.

OTP block 0 is pre-programmed with a unique 64-bit value and locked at the factory. OTP block 1 contains all 1s and is user-programmable. OTP blocks 1 through 16 contain all 1s and are user-programmable.

Each OTP block can be accessed multiple times to program individual bits, as long as the block remains unlocked. When a lock register bit is programmed, the associated OTP block can only be read—it can no longer be programmed.

OTP lock register bits lock out subsequent programming of the corresponding OTP block. Each OTP block can be locked by programming its corresponding lock bit to 0. As long as an OTP block remains unlocked (that is, its lock bit = 1), any of its remaining 1 bits can be programmed to 0.

Note: Once an OTP block is locked, it cannot be unlocked. Attempts to program a locked OTP block will fail with error bits set. Additionally, because the lock register bits themselves are OTP, when programmed, lock register bits cannot be erased. Therefore, when an OTP block is locked, it cannot be unlocked.

Table 29: Program OTP Area Command Bus Cycles

Command	Setup WRITE Cycle Address Bus	Setup WRITE Cycle Data Bus	Confirm WRITE Cycle Address Bus	Confirm WRITE Cycle Data Bus
PROGRAM OTP AREA	Device address	00C0h	OTP register address	Register data

Figure 13: OTP Area Map

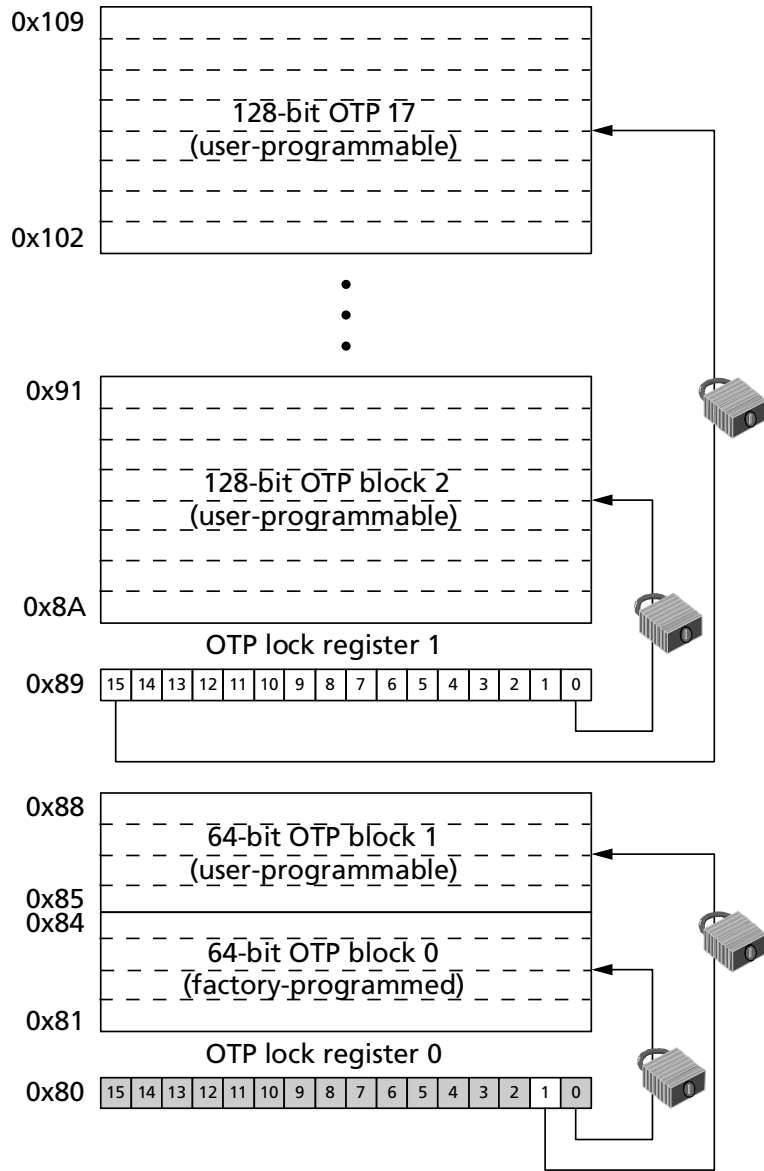

Programming OTP Area

OTP area programming is performed 16 bits at a time; only zeros within the data word affect any change to the OTP bits.

To program any OTP blocks or lock registers, first issue the PROGRAM OTP AREA SETUP command at any device address. The read state of that partition changes to read status. Next, write the desired OTP data at the desired OTP address.

Attempting to program outside of the OTP area causes a program error (SR[4] = 1).

Attempting to program a locked OTP block causes a program error and a lock error (SR[4] = 1, SR[1] = 1).

OTP area programming cannot be suspended. Dual operations between the parameter partition and the OTP area are not allowed.

Reading OTP Area

The OTP area is read from within the address space of any partition. To read from the OTP area, the following must be done:

1. Issue the READ ID command at the address of any partition to place that partition in the read ID state.
2. Perform a READ operation at the base address of that partition, plus the address offset corresponding to the OTP word to be read. Data is read 16 bits at a time.

If a PROGRAM or ERASE operation occurs within the device while it is reading from the OTP area, certain restrictions may apply.

Global Main-Array Protection

Global main-array protection can be implemented by controlling V_{pp} . When programming or erasing main-array blocks, V_{pp} must be equal to or greater than $V_{PPL, min}$. When V_{pp} is below V_{PPLK} , PROGRAM or ERASE operations are inhibited, thus providing absolute protection of the main array.

Various methods exist for controlling V_{pp} , ranging from simple logic control to off-board voltage control. The following figure shows example V_{pp} supply connections that can be used to support PROGRAM or ERASE operations and main-array protection.

Figure 14: V_{pp} Supply Connection Example

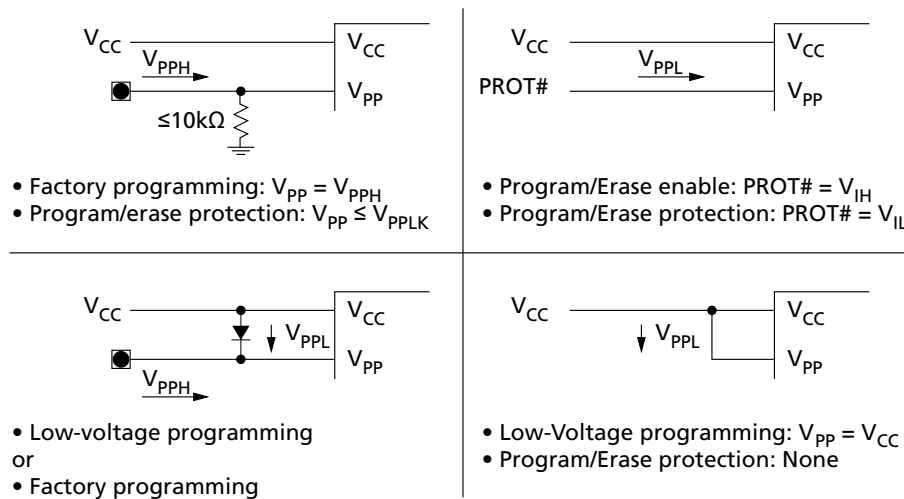

Dual Operation

Multipartition architecture of the device enables reading from one partition while a PROGRAM or ERASE operation is occurring in another partition. This is called read-while-program and read-while-erase, respectively.

Only status reads are allowed from a partition that is busy programming or erasing. If non-status reads are required from a partition that is busy programming or erasing, the PROGRAM or ERASE operation must be suspended first.

Table 30: Dual Operation Restrictions

The following table shows the allowed dual operations between array operations and non-array operations

Read	Program or Erase Main Partition	Program OTP Area
Main Partition	Yes (except busy partition)	Yes (except busy partition)
Status	Yes	Yes
ID, OTP, or CFI	Yes (except busy partition)	No

Power and Reset Specifications

Initialization

Proper device initialization and operation is dependent on the power-up/down sequence, reset procedure, and adequate power-supply decoupling.

Power-Up and Down

To avoid conditions that may result in spurious PROGRAM or ERASE operations, the power sequences shown below are recommended. Note that each power supply must be at its minimum voltage range before applying or removing the next supply voltage in the sequence. Also, device inputs must not be driven until all supply voltages have attained their minimum range, and RST# should be LOW during all power transitions.

When powering down the device, voltages should reach 0V before power is reapplied to ensure proper device initialization. Otherwise, indeterminate operation could result.

When V_{CCQ} goes below V_{LKOQ} , the device is reset.

Table 31: Power Sequencing

Power Supply	Power-Up Sequence				Power-Down Sequence			
$V_{CC,min}$	First	First	First ¹	First ¹	Third	Second	Second ¹	Second ¹
$V_{CCQ,min}$	Second	Second ¹	First ¹	Second	Second	First ¹	Second ¹	First
$V_{PP,min}$	Third	Second ¹	Second	First ¹	First	First ¹	First	Second ¹

Note: 1. Connected/sequenced together.

Reset

During power-up and power-down, RST# should be asserted to prevent spurious PROGRAM or ERASE operations. While RST# is LOW, device operations are disabled, all inputs such as address and control are ignored, and all outputs such as data and WAIT are placed in High-Z. Invalid bus conditions are effectively masked out.

Upon power-up, RST# can be de-asserted after t_{VCCPH} , allowing the device to exit from reset. Upon exiting from reset, the device defaults to asynchronous read array mode, and the status register defaults to 0080h. Array data is available after t_{PHQV} , or a bus WRITE cycle can begin after t_{PHWL} . If RST# is asserted during a PROGRAM or ERASE operation, the operation will abort and array contents at that location will be invalid.

For proper system initialization, connect RST# to the LOW true reset signal that asserts whenever the processor is reset. This will ensure the device is in the expected read mode (read array) upon startup.

Figure 15: RESET Operation Waveforms

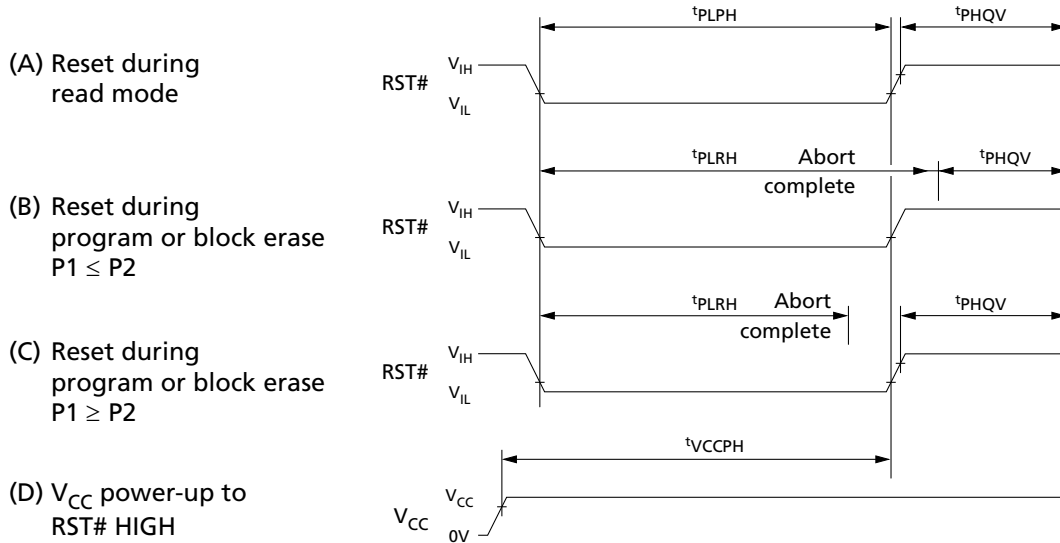

Table 32: Reset Specifications

Note 1 applies to all

Parameter	Symbol	Min	Max	Unit	Notes
RST# pulse width LOW	t_{PLPH}	100	–	ns	2, 3, 6
RST# LOW to device reset during erase	t_{PLRH}	–	25	μ s	3, 6
RST# LOW to device reset during program		–	25		3, 6
V_{CC} power valid to RST# de-assertion (HIGH)	t_{VCCPH}	300	–		4, 5

- Notes:
1. These specifications are valid for all packages and speeds, and are sampled, not 100% tested.
 2. The device might reset if t_{PLPH} is $< t_{PLPH}$ MIN, but this is not guaranteed.
 3. Not applicable if RST# is tied to V_{CCQ} .
 4. If RST# is tied to the V_{CC} supply, the device is not ready until t_{VCCPH} after $V_{CC} \geq V_{CC,min}$.
 5. If RST# is tied to any supply/signal with V_{CCQ} voltage levels, the RST# input voltage must not exceed V_{CC} until $V_{CC} \geq V_{CC,min}$.
 6. Reset completes within t_{PLPH} if RST# is asserted while no ERASE or PROGRAM operation is executing.

Automatic Power Saving

Automatic power saving provides low-power operation following reads during active mode. After data is read from the memory array and the address lines are quiescent, automatic power savings automatically places the device into standby. In automatic power savings, device current is reduced to I_{CCAPS} .

Power Supply Decoupling

Flash memory devices require careful power supply decoupling to prevent external transient noise from affecting device operations, and to prevent internally generated transient noise from affecting other devices in the system.

Ceramic chip capacitors of 0.01 μ F to 0.1 μ F should be used between all V_{CC} , V_{CCQ} , and V_{PP} supply connections and system ground. These high-frequency, inherently low-inductance capacitors should be placed as close as possible to the device package, or on the opposite side of the printed circuit board close to the center of the device package footprint.

Larger (4.7 μ F to 33.0 μ F) electrolytic or tantalum bulk capacitors should also be distributed as needed throughout the system to compensate for voltage sags and surges caused by circuit trace inductance.

Transient current magnitudes depend on the capacitive and inductive loading on the device's outputs. For best signal integrity and device performance, high-speed design rules should be used when designing the printed-circuit board. Circuit-trace impedances should match output-driver impedance with adequate ground-return paths. This will help minimize signal reflections (overshoot/undershoot) and noise caused by high-speed signal edge rates.

Electrical Specifications

Stresses greater than those listed may cause permanent damage to the device. This is a stress rating only. Exposure to absolute maximum rating and operating conditions for extended periods may adversely affect reliability. Stressing the device beyond the absolute maximum ratings may cause permanent damage. These are stress ratings only.

Table 33: Absolute Maximum Ratings

Parameter	Min	Max	Units	Notes
Temperature under bias (T_A)	-30	85	°C	5
Storage temperature (T_A)	-65	125	°C	5
V_{PP} voltage	-2.0	11.5	V	1, 2, 3
V_{CC} voltage	-2.0	$V_{CCQ} + 2.0$	V	1
Voltage on any input/output signal (except V_{CC} , V_{CCQ} , and V_{PP})	-2.0	$V_{CCQ} + 2.0$	V	2
V_{CCQ} voltage	-0.2	$V_{CCQ} + 2.0$	V	1
V_{PPH} time	-	80	hours	3
Output short circuit current	-	100	mA	4
Block Program/Erase Cycles: Main Blocks	100,000	-	Cycles	3

- Notes:
1. Voltages shown are specified with respect to V_{SS} . During transitions, the voltage potential between V_{SS} and input/output and supply pins may undershoot to -1.0V for periods less than 20ns and may overshoot to $V_{CCQ(max)} + 1.0V$ for periods less than 20ns.
 2. Voltages shown are specified with respect to V_{SS} . During transitions, the voltage potential between V_{SS} and supply pins may undershoot to -2.0V for periods less than 20ns and may overshoot to $V_{CC(max)} + 2.0V$ for periods less than 20ns.
 3. Operation beyond this limit may degrade performance.
 4. Output shorted for no more than one second; no more than one output shorted at a time.
 5. Temperature specified is ambient (T_A), not case (T_C).

Table 34: Operating Conditions

Symbol	Parameter	Min	Max	Units	Notes
T_C	Operating temperature	-30	85	°C	1
V_{CC}	V_{CC} supply voltage	1.7	2.0	V	
V_{CCQ}	I/O supply voltage	1.7	2.0	V	
V_{PPL}	V_{PP} voltage supply (logic level)	0.9	2.0	V	
V_{PPH}	Factory programming V_{PP}	8.5	9.5	V	

Note: 1. T_C = Case temperature, not ambient.



Electrical Specifications – DC Current and Voltage Characteristics and Operating Conditions

Table 35: DC Current Characteristics and Operating Conditions

Parameter	Symbol	Conditions	Litho (nm)	Density (Mbit)	1.7 V - 2.0 V		Unit	Notes
					Typ	Max		
Input Load, Output Leakage, Standby								
Input load current	I_{LI}	$V_{CC} = V_{CC,max}; V_{CCQ} = V_{CCQ,max}; V_{IN} = V_{CCQ}$ or V_{SS}	–	–	–	± 1	μA	1
Output leakage current	I_{LO}	$V_{CC} = V_{CC,max}; V_{CCQ} = V_{CCQ,max}; V_{IN} = V_{CCQ}$ or V_{SS}	–	–	–	± 1	μA	1
V_{CC} standby	I_{CCS}, I_{CCD}	$V_{CC} = V_{CC,max}; V_{CCQ} = V_{CCQ,max}; CE\# = V_{CCQ}; RST\# = V_{CCQ}$ or GND (for I_{CCS}); $WP\# = V_{IH}$	90	256	35	95	μA	1, 2
				512	50	120		
			65	128	45	115		
				256	50	130		
			512	60	160			
			1024	70	185			
			45	128	18	100		
				256	18	100		
				512	18	100		
				1024	20	140		
Average VCC Read								
Average V_{CC} read current; Asynchronous single-word read; $f = 5$ MHz; 1 CLK	I_{CCR}	$V_{CC} = V_{CC,max}; CE\# = V_{IL}; OE\# = V_{IH};$ Inputs: V_{IL} or V_{IH}	–	–	25	30	mA	1, 3, 4
Average V_{CC} read current; Page mode read; $f = 13$ MHz; 17 CLK; Burst = 16-word	I_{CCR}	$V_{CC} = V_{CC,max}; CE\# = V_{IL}; OE\# = V_{IH};$ Inputs: V_{IL} or V_{IH}	–	–	11	15	mA	1, 3, 4
Average V_{CC} read current; Synchronous burst read; $f = 66$ MHz; LC = 7; Burst = 8-word; Burst = 16-word; Burst = Continuous	I_{CCR}	$V_{CC} = V_{CC,max}; CE\# = V_{IL}; OE\# = V_{IH};$ Inputs: V_{IL} or V_{IH}	–	–	22 19 25	32 26 34	mA	1, 3, 4



128Mb, 256Mb, 512Mb, 1Gb StrataFlash Memory

Electrical Specifications – DC Current and Voltage Characteristics and Operating Conditions

Table 35: DC Current Characteristics and Operating Conditions (Continued)

Parameter	Symbol	Conditions	Litho (nm)	Density (Mbit)	1.7 V - 2.0 V		Unit	Notes
					Typ	Max		
Average V_{CC} read current; Synchronous burst read; $f = 108$ MHz; $LC = 10$; Burst = 8-word; Burst = 16-word; Burst = Continuous	I_{CCR}	$V_{CC} = V_{CC,max}$; $CE\# = V_{IL}$; $OE\# = V_{IH}$; Inputs: V_{IL} or V_{IH}	–	–	26 23 30	36 30 42	mA	1, 3, 4
Average V_{CC} read current; Synchronous burst read; $f = 133$ MHz; $LC = 13$; Burst = 8-word; Burst = 16-word; Burst = Continuous	I_{CCR}	$V_{CC} = V_{CC,max}$; $CE\# = V_{IL}$; $OE\# = V_{IH}$; Inputs: V_{IL} or V_{IH}	–	–	26 24 33	35 33 46	mA	1, 3, 4
VCC Program, Erase, Blank Check								
V_{CC} Program V_{CC} Erase V_{CC} Blank Check	I_{CCW} , I_{CCE} , I_{CCBC}	$V_{PP} = V_{PPL}$ or $V_{PP} = V_{PPH}$; Program/erase in progress	–	–	35	50	mA	1, 3, 4, 5
V_{CC} Program suspend V_{CC} Erase suspend	I_{CCWS} , I_{CCES}	$CE\# = V_{CCQ}$; Suspend in progress	90 65 45	256 512 128 256 512 1024 128 256 512 1024	35 50 45 50 60 70 18 18 18 20	95 120 115 130 160 185 100 100 100 140	μ A	1, 3, 6
VPP Program, Read, Erase, Blank Check, Standby								
V_{PP} standby current; V_{PP} program suspend current; V_{PP} erase suspend current	I_{PPS} , I_{PPWS} , I_{PPE}	$V_{PP} = V_{PPL}$; Suspend in progress	–	–	0.2	5	μ A	3
V_{PP} read	I_{PPR}	$V_{PP} \leq V_{CC}$	–	–	2	15	μ A	3
V_{PP} program current	I_{PPW}	$V_{PP} = V_{PPL} = V_{PPH}$; Program in progress	–	–	0.05	0.10	mA	3
V_{PP} erase current	I_{PPE}	$V_{PP} = V_{PPL} = V_{PPH}$; Erase in progress	–	–	0.05	0.10	mA	3



128Mb, 256Mb, 512Mb, 1Gb StrataFlash Memory Electrical Specifications – DC Current and Voltage Characteristics and Operating Conditions

Table 35: DC Current Characteristics and Operating Conditions (Continued)

Parameter	Symbol	Conditions	Litho (nm)	Density (Mbit)	1.7 V - 2.0 V		Unit	Notes
					Typ	Max		
V _{pp} blank check current	I _{ppBC}	V _{pp} = V _{pPL} = V _{ppH} ; Blank check in progress	–	–	0.05	0.10	mA	3
Automatic Power Savings								
Automatic power savings	I _{CCAPS}	V _{CC} = V _{CC,maxi} ; V _{CCQ} = V _{CCQ,maxi} ; CE# = V _{SSQ} ; RST# = V _{CCQ} ; All inputs are at rail-to-rail (V _{CCQ} or V _{SSQ})	90	256	35	95	μA	–
				512	50	120		
			65	128	45	115		
				256	50	130		
				512	60	160		
				1024	70	185		
			45	128	18	100		
				256	18	100		
				512	18	100		
				1024	20	140		

- Notes:
1. All currents are RMS unless noted. Typical values at typical V_{CCQ}, T_C = +25°C.
 2. I_{CCS} is the average current measured over any 5ms time interval 5μs after CE# is de-asserted.
 3. Sampled, not 100% tested.
 4. V_{CC} read + program current is the sum of V_{CC} read and V_{CC} program currents. V_{CC} read + erase current is the sum of V_{CC} read and V_{CC} erase currents.
 5. I_{CCW}, I_{CCER} is measured over typical or max times specified in Program and Erase Characteristics.
 6. I_{CCES} is specified with the device deselected. If the device is read while in erase suspend, current is I_{CCES} + I_{CCR}.



Table 36: DC Voltage Characteristics and Operating Conditions

Parameter	Symbol	Conditions	V _{CCQ} = 1.7V - 2.0V		Unit	Notes
			Min	Max		
Input low voltage	V _{IL}	–	0	0.45	V	1
Input high voltage	V _{IH}	–	V _{CCQ} - 0.45	V _{CCQ}	V	1
Output low voltage	V _{OL}	V _{CC} = V _{CC,min} ; V _{CCQ} = V _{CCQ,min} ; I _{OL} = 100μA	–	0.1	V	
Output high voltage	V _{OH}	V _{CC} = V _{CC,min} ; V _{CCQ} = V _{CCQ,min} ; I _{OL} = 100μA	V _{CCQ} - 0.1	–	V	
V _{PP} lockout voltage	V _{PPLK}	–	–	0.4	V	2
V _{CC} lock voltage	V _{LKO}	–	1.0	–	V	
V _{CCQ} lock voltage	V _{LKOQ}	–	0.9	–	V	

- Notes:
1. Input voltages can undershoot to –1.0V and overshoot to V_{CCQ} + 1V for durations of 2ns or less.
 2. V_{PP} < V_{PPLK} inhibits ERASE and PROGRAM operations. Do not use V_{PP}L and V_{PP}H outside of their valid ranges.

Electrical Specifications – AC Characteristics and Operating Conditions

AC Test Conditions

Figure 16: AC Input/Output Reference Waveform

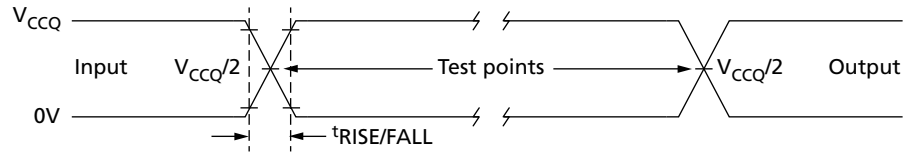

Note: 1. AC test inputs are driven at V_{CCQ} for Logic 1, and 0.0V for Logic 0. Input/output timing begins/ends at $V_{CCQ}/2$. Input rise and fall times (10% to 90%) <5ns. Worst-case speed occurs at $V_{CC} = V_{CC,min}$.

Table 37: AC Input Requirements

Parameter	Symbol	Frequency	Min	Max	Unit	Condition
Inputs rise/fall time (Address, CLK, CE#, OE#, ADV#, WE#, WP#)	$t_{RISE/FALL}$	@133 MHz, 108 MHz	0.3	1.2	ns	V_{IL} to V_{IH} or V_{IH} to V_{IL}
		@66 MHz	0	3		
Address-address skew ¹	t_{ASKW}		0	3	ns	@ $V_{CCQ}/2$

Note: 1. For an address to be latched the skew is defined as the time when the first address bit is valid to the last address bit going valid.

Figure 17: Transient Equivalent Testing Load Circuit

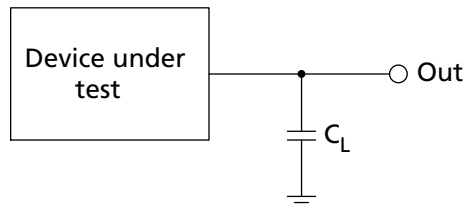

Notes: 1. See Test Configuration Load Capacitor Values for Worst Case Speed Conditions table for component values for the test configurations.
2. C_L includes jig capacitance.

Table 38: Test Configuration Load Capacitor Values for Worst Case Speed Conditions

Test Configuration	C_L (pF)
1.7V Standard test	30
2.0V Standard test	30

Figure 18: Clock Input AC Waveform

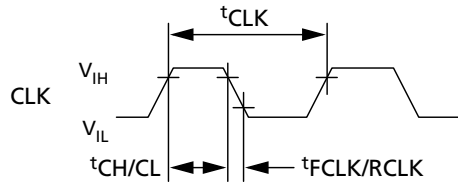

Table 39: Capacitance

Notes 1, 2, and 3 apply to all parameters

Parameter	Symbol	Signals	Min	Typ	Max	Unit	Test Condition
Input capacitance	C_{IN}	Address, CLK, CE#, OE#, ADV#, WE#, WP#, DPD, and RST#	2	4	6	pF	$V_{IN} = 0-2.0V$
Output capacitance	C_{OUT}	Data, WAIT	2	5	6	pF	$V_{OUT} = 0-2.0V$

- Notes:
1. $TC = +25^{\circ}C$, $f = 1\text{ MHz}$.
 2. Sampled, not 100% tested.
 3. Silicon die capacitance only. For discrete packages, add 1pF. For stacked packages, total capacitance = 2pF + sum of silicon die capacitances.



AC Read Specifications

AC Read Specifications (CLK-Latching, 133 MHz)

Table 40: AC Read Specifications (CLK-Latching, 133 MHz), $V_{CCQ} = 1.7V$ to $2.0V$

Note 1 applies to all parameters

Parameter	Symbol	96ns		Unit	Notes
		Min	Max		
Asynchronous Specifications					
READ cycle time	t_{AVAV}	96	–	ns	
Address to output valid	t_{AVQV}	–	96	ns	
CE# LOW to output valid	t_{ELQV}	–	96	ns	
OE# LOW to output valid	t_{GLQV}	–	7	ns	2
RST# HIGH to output valid	t_{PHQV}	–	150	ns	
CE# LOW to output in Low-Z	t_{ELQX}	0	–	ns	3
OE# LOW to output in Low-Z	t_{GLQX}	0	–	ns	2, 3
CE# HIGH to output in High-Z	t_{EHQZ}	–	7	ns	3
OE# HIGH to output in High-Z	t_{GHQZ}	–	7	ns	3
Output hold from first occurring address, CE#, or OE# change	t_{OH}	0	–	ns	3
CE# pulse width HIGH	t_{EHEL}	7	–	ns	
CE# LOW to WAIT valid	t_{ELTV}	–	8	ns	
CE# HIGH to WAIT High-Z	t_{EHTZ}	–	7	ns	3
OE# HIGH to WAIT valid (A/D MUX only)	t_{GHTV}	–	5.5	ns	
OE# LOW to WAIT valid	t_{GLTV}	–	5.5	ns	
OE# LOW to WAIT in Low-Z	t_{GLTX}	0	–	ns	3
OE# HIGH to WAIT in High-Z (non-MUX only)	t_{GHTZ}	0	7	ns	3
Latching Specifications					
Address setup to ADV# HIGH	t_{AVVH}	5	–	ns	
CE# LOW to ADV# HIGH	t_{ELVH}	7	–	ns	
ADV# LOW to output valid	t_{VLQV}	–	96	ns	
ADV# pulse width LOW	t_{VLVH}	7	–	ns	
ADV# pulse width HIGH	t_{VHVL}	7	–	ns	
Address hold from ADV# HIGH	t_{VHAX}	5	–	ns	
ADV# HIGH to OE# LOW (A/D MUX only)	t_{VHGL}	2	–	ns	
Page address access (non-MUX only)	t_{APA}	–	15	ns	
RST# HIGH to ADV# HIGH	t_{PHVH}	30	–	ns	
Clock Specifications					
CLK frequency	f_{CLK}	–	133	MHz	
CLK period	t_{CLK}	7.5	–	ns	
CLK HIGH/LOW time	$t_{CH/CL}$	0.45	0.55	CLK period	

Table 40: AC Read Specifications (CLK-Latching, 133 MHz), V_{CCQ} = 1.7V to 2.0V (Continued)

Note 1 applies to all parameters

Parameter	Symbol	96ns		Unit	Notes
		Min	Max		
CLK fall/rise time	^t FLK/RCLK	0.3	1.2	ns	
Synchronous Specifications					
Address setup to CLK HIGH	^t AVCH	2	–	ns	
ADV# LOW setup to CLK HIGH	^t VLCH	2	–	ns	
CE# LOW setup to CLK HIGH	^t ELCH	2.5	–	ns	
CLK to output valid	^t CHQV	–	5.5	ns	
Output hold from CLK HIGH	^t CHQX	2	–	ns	
Address hold from CLK HIGH	^t CHAX	2	–	ns	
CLK HIGH to WAIT valid	^t CHTV	–	5.5	ns	
ADV# HIGH hold from CLK	^t CHVL	2	–	ns	
WAIT hold from CLK	^t CHTX	2	–	ns	
ADV# hold from CLK HIGH	^t CHVH	2	–	ns	4
CLK to OE# LOW (A/D MUX only)	^t CHGL	2	–	ns	
Read access time from address latching clock	^t ACC	96	–	ns	
ADV# pulse width LOW for sync reads	^t VLVH	1	2	clocks	4
ADV# HIGH to CLK HIGH	^t VHCH	2	–	ns	4

- Notes:
1. See Electrical Specifications – AC Characteristics and Operating Conditions for timing measurements and MAX allowable input slew rate.
 2. OE# can be delayed by up to ^tELQV - ^tGLQV after the CE# falling edge without impact to ^tELQV.
 3. Sampled, not 100% tested.
 4. For 45nm devices, these specifications are not required as a result of the enhanced CLK-latching scheme. See the StrataFlash[®] Cellular Memory 65nm to 45nm M Family Migration Guide and the StrataFlash[®] Cellular Memory 65nm to 45nm M Family Latching Scheme Migration Guide for more information.

AC Read Timing

The Synchronous read timing waveforms apply to both 108 and 133 MHz devices. However, devices that only support up to 108 MHz need not meet the following timing specifications.

- ^tCHVH
- ^tCHGL
- ^tACC
- ^tVLVH
- ^tVHCH

Note: The WAIT signal polarity in all the timing waveforms is low-true (RCR10 = 0). WAIT is shown as de-asserted with valid data (RCR8 = 0). WAIT is de-asserted during asynchronous reads.

Figure 19: Asynchronous Page-Mode Read (Non-MUX)

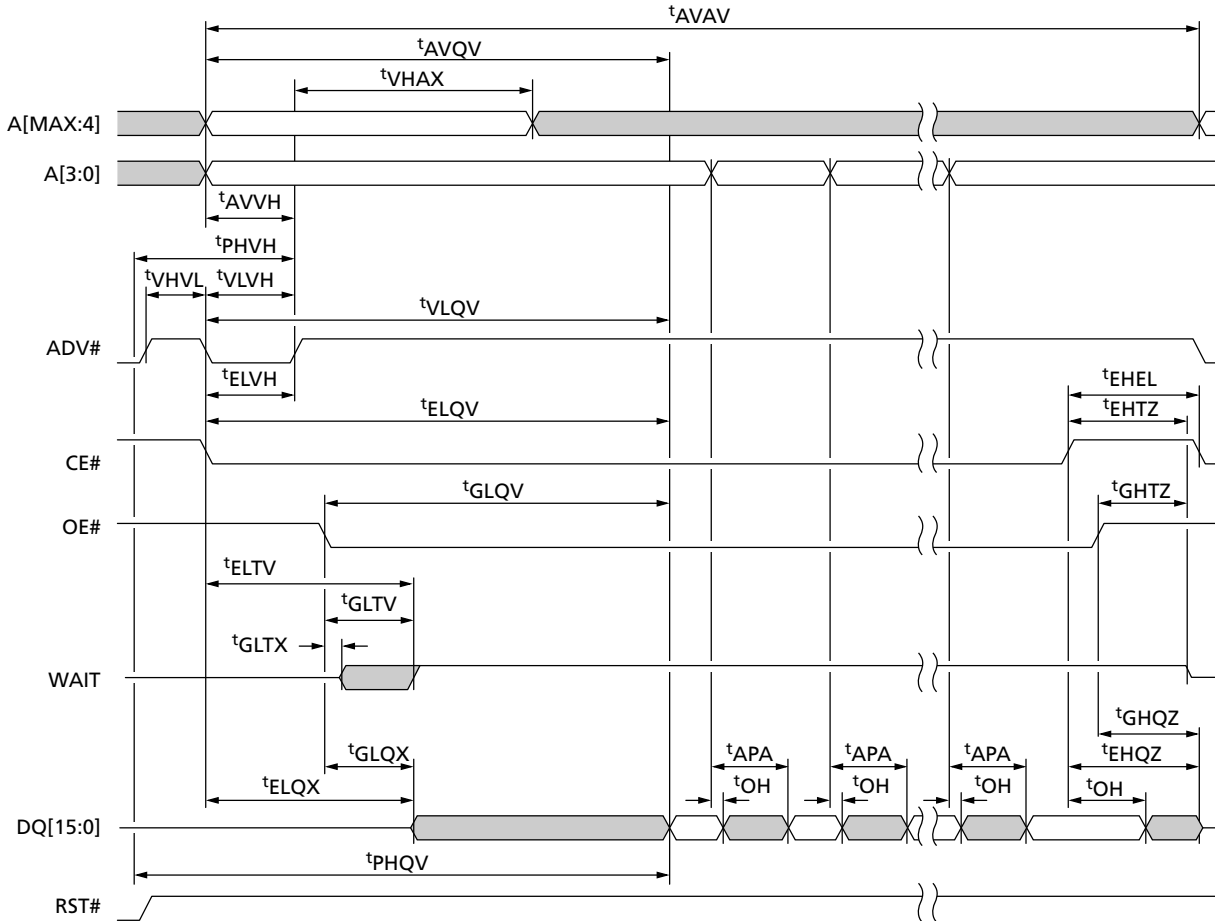

Note: 1. WAIT shown active LOW (RCR[10] = 0).

Figure 20: Synchronous 8- or 16-Word Burst Read (Non-MUX)

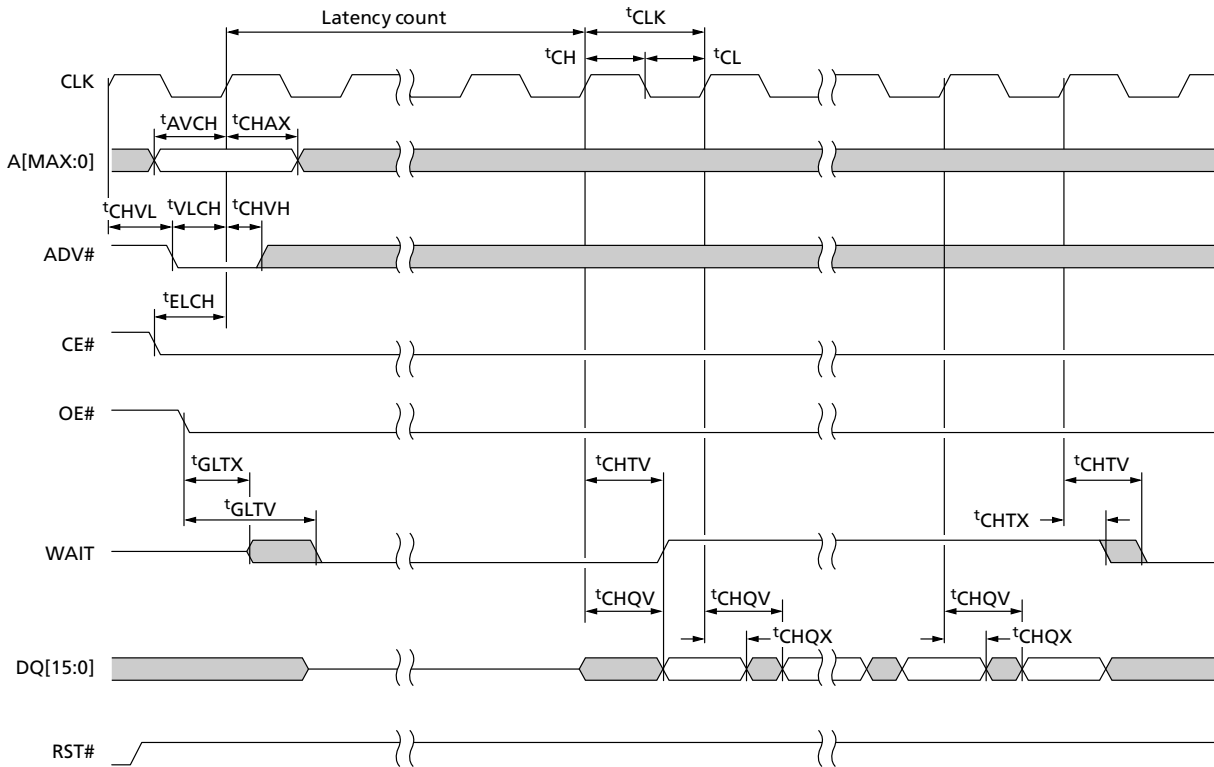

- Notes:
1. 8-word and 16-word burst are always wrap-only.
 2. WAIT shown as active LOW (RCR[10] = 0) and asserted with data (RCR[8] = 0).
 3. ADV# may be held LOW throughout the synchronous READ operation.
 4. t_{AVQV} , t_{ELQV} , and t_{VLQV} apply to legacy-latching only.
 5. t_{ACC} and t_{VLVH} apply to clock-latching only.

Figure 21: Synchronous Continuous Misaligned Burst Read (Non-MUX)

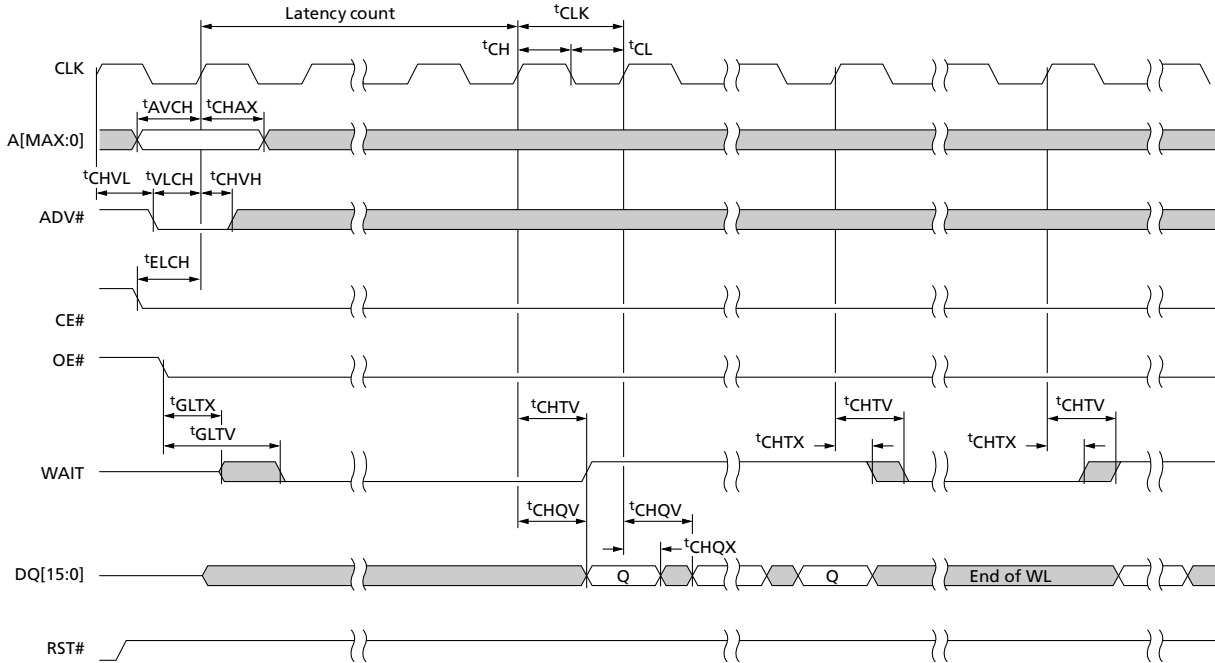

- Notes:
1. WAIT shown as active LOW (RCR[10] = 0) and asserted with data (RCR[8] = 0).
 2. ADV# may be held LOW throughout the synchronous READ operation.
 3. t_{AVQV} , t_{ELQV} , and t_{VLQV} apply to legacy-latching only.
 4. t_{ACC} and t_{VLVH} apply to clock-latching only.

Figure 22: Synchronous Burst with Burst Interrupt Read (Non-MUX)

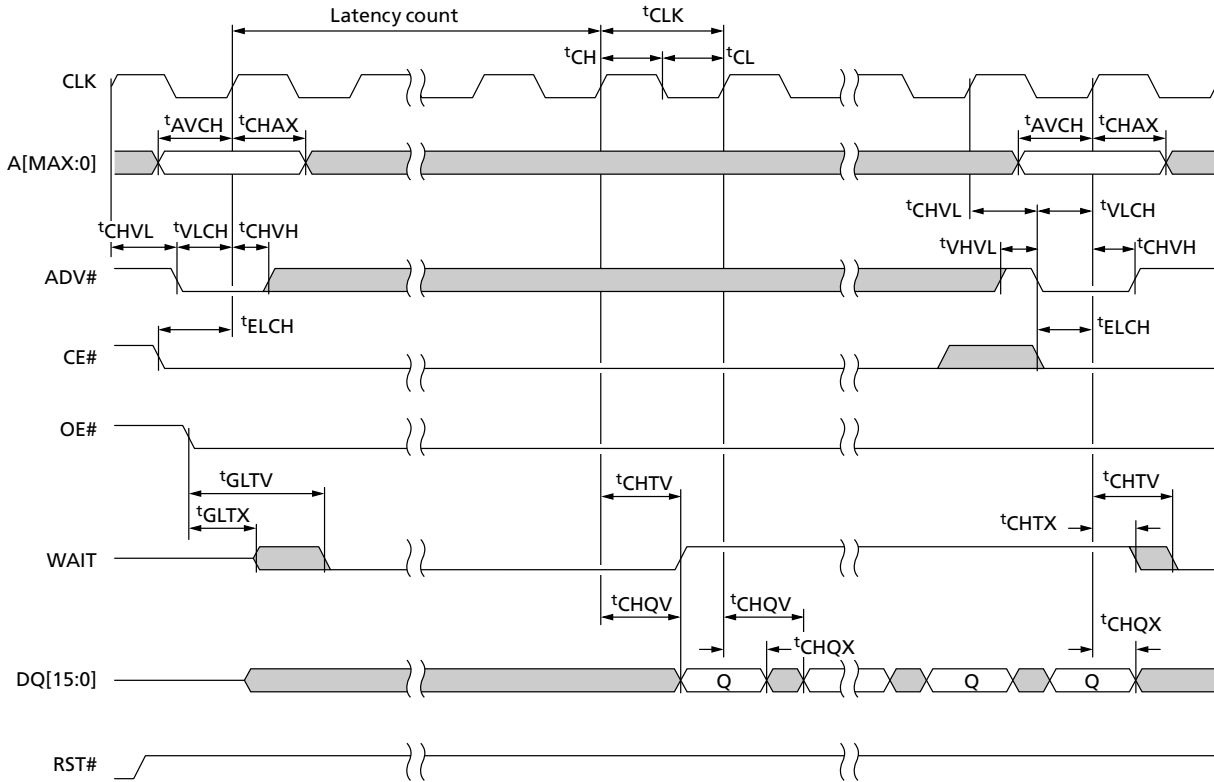

- Notes:
1. WAIT shown as active LOW (RCR[10] = 0) and asserted with data (RCR[8] = 0).
 2. A burst can be interrupted by toggling CE# or ADV#.
 3. For no-wrap bursts, end-of-wordline WAIT states could occur (not shown in this figure).
 4. t_{AVQV} , t_{ELQV} , and t_{VLQV} apply to legacy-latching only.
 5. t_{ACC} and t_{VLVH} apply to clock-latching only.

Figure 23: Asynchronous Single-Word Read

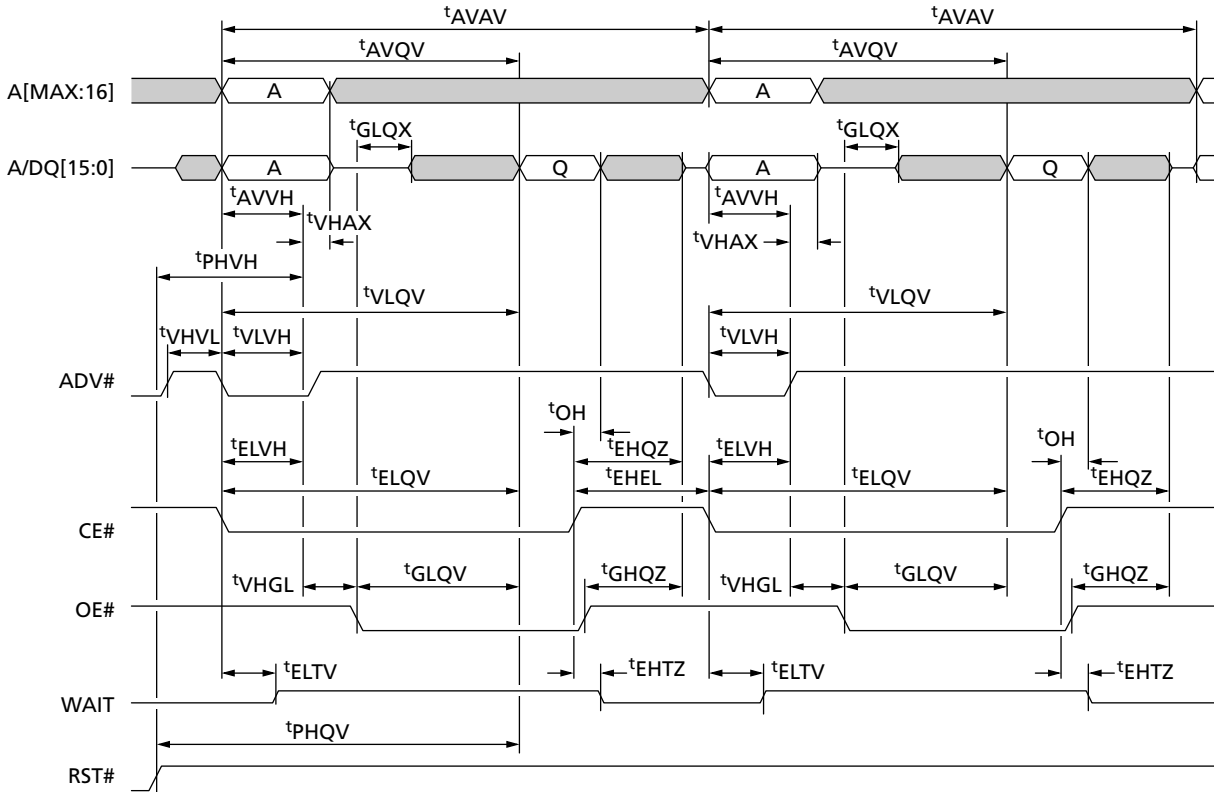

- Notes:
1. WAIT shown as active LOW (RCR[10] = 0).
 2. Back-to-back READ operations shown.
 3. CE# does not need to toggle between read cycles (i.e., t_{EHEL} need not apply).

Figure 24: Synchronous 8- or 16-Word Burst Read (A/D MUX)

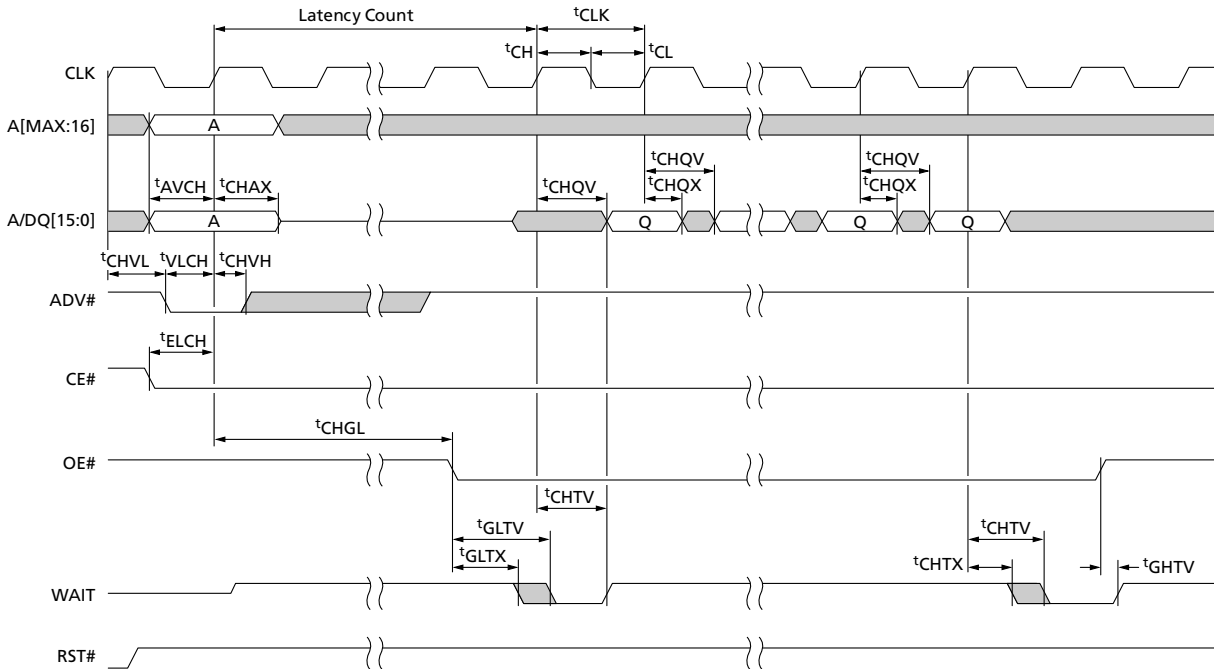

- Notes:
1. 8-word and 16-word burst are always wrap-only.
 2. WAIT shown as active LOW (RCR[10] = 0) and asserted with data (RCR[8] = 0).
 3. t_{AVQV} , t_{ELQV} , and t_{VLQV} apply to legacy-latching only.
 4. t_{ACC} and t_{VLVH} apply to clock-latching only.

Figure 25: Synchronous Continuous Misaligned Burst Read (A/D MUX)

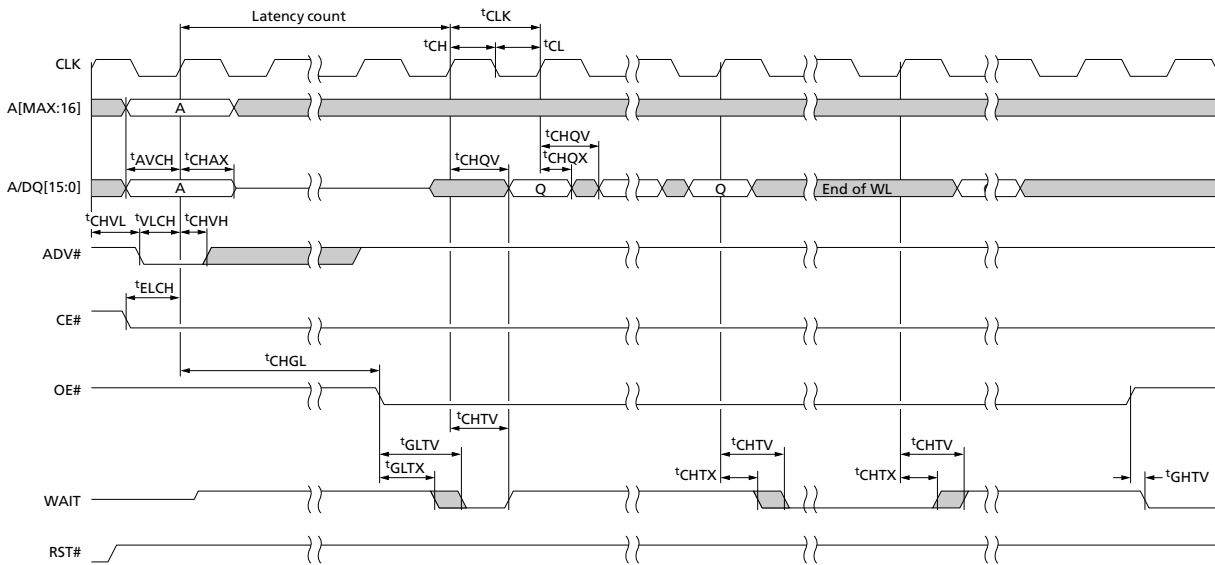

- Notes:
1. 8-word and 16-word burst are always wrap-only.
 2. WAIT shown as active LOW (RCR[10] = 0) and asserted with data (RCR[8] = 0).
 3. tAVQV, tELQV, and tVLQV apply to legacy-latching only.
 4. tACC and tVLVH apply to clock-latching only.

Figure 26: Synchronous Burst with Burst-Interrupt (AD-Mux)

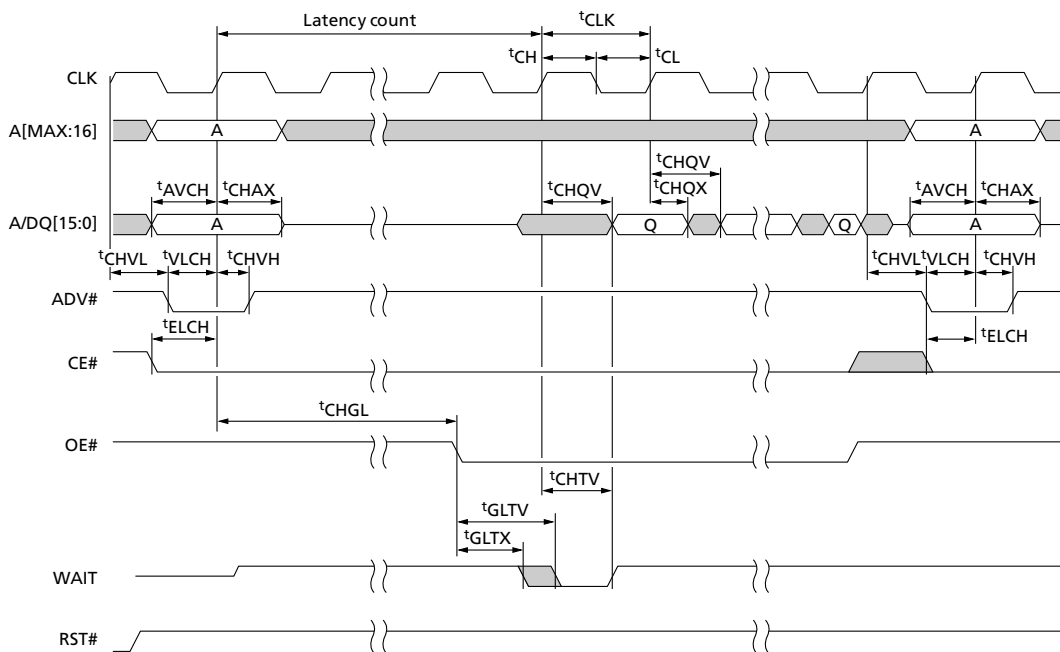



128Mb, 256Mb, 512Mb, 1Gb StrataFlash Memory AC Read Specifications

- Notes:
1. t_{AVQV} , t_{ELQV} , and t_{VLQV} apply to legacy-latching only.
 2. t_{ACC} and t_{VLVH} apply to clock-latching only.
 3. A burst can be interrupted by toggling CE# or ADV#.

AC Write Specifications

Table 41: AC Write Specifications

Notes 1 and 2 apply to all

Parameter	Symbol	Min	Max	Unit	Notes
RST# HIGH recovery to WE# LOW	t_{PHWL}	150	–	ns	3
CE# setup to WE# LOW	t_{ELWL}	0	–	ns	10
WE# write pulse width LOW	t_{WLWH}	40	–	ns	4
Data setup to WE# HIGH	t_{DVWH}	40	–	ns	
Address setup to WE# HIGH	t_{AVWH}	40	–	ns	
CE# hold from WE# HIGH	t_{WHEH}	0	–	ns	
Data hold from WE# HIGH	t_{WHDX}	0	–	ns	
Address hold from WE# HIGH	t_{WHAX}	0	–	ns	
WE# pulse width HIGH	t_{WHWL}	20	–	ns	5
V_{PP} setup to WE# HIGH	t_{VPWH}	200	–	ns	3, 7
V_{PP} hold from status read	t_{QVVL}	0	–	ns	3, 7
WP# hold from status read	t_{QVBL}	0	–	ns	3, 7
WP# setup to WE# HIGH	t_{BHWH}	200	–	ns	3, 7
WE# HIGH to OE# LOW	t_{WHGL}	0	–	ns	8
ADV# LOW to WE# HIGH	t_{VLWH}	55	–	ns	
WE# HIGH to read valid	t_{WHQV}	$t_{AVQV} + 30$	–	ns	3, 6, 9
WRITE Operation to Asynchronous Read Transition					
WE# HIGH to address valid	t_{WHAV}				
Write to Synchronous Read Specification					
WE# HIGH to CLK HIGH @ 110 MHz	t_{WHCH}	15	–	ns	3, 6, 11
WE# HIGH to CE# LOW	t_{WHEL}	9	–	ns	3, 6, 11
WE# HIGH to ADV# LOW	t_{WHVL}	7	–	ns	3, 6, 11
Write Specifications with Clock Active					
ADV# HIGH to WE# LOW	t_{VHWL}	–	27	ns	11
CLK HIGH to WE# LOW	t_{CHWL}	–	27	ns	11

- Notes:
1. Write timing characteristics during erase suspend are the same as WRITE-only operations.
 2. A WRITE operation can be terminated with either CE# or WE#.
 3. Sampled, not 100% tested.
 4. Write pulse width LOW (t_{WLWH} or t_{ELEH}) is defined from CE# or WE# LOW (whichever occurs last) to CE# or WE# HIGH (whichever occurs first). Hence, $t_{WLWH} = t_{ELEH} = t_{WLEH} = t_{ELWH}$.
 5. Write pulse width HIGH (t_{WHWL} or t_{EHEL}) is defined from CE# or WE# HIGH (whichever occurs first) to CE# or WE# LOW (whichever occurs last). Hence, $t_{WHWL} = t_{EHEL} = t_{WHEL} = t_{EHW}$.
 6. t_{WHCH} must be met when transitioning from a WRITE cycle to a synchronous burst read. In addition CE# or ADV# must toggle when WE# goes HIGH.
 7. V_{PP} and WP# must be at a valid level until erase or program success is determined.

8. When performing a READ STATUS operation following any command that alters the status register, t_{WHGL} is 20ns.
9. Add 10ns if the WRITE operation results in an RCR or block lock status change for the subsequent READ operation to reflect this change.
10. Either t_{VHWL} or t_{CHWL} is required to meet the specification depending on the address latching mechanism; both of these specifications can be ignored if the clock is not toggling during the WRITE cycle.
11. If $ADV\#$ remains LOW after the WRITE cycle completes, a new READ cycle will start.

Figure 27: Write Timing

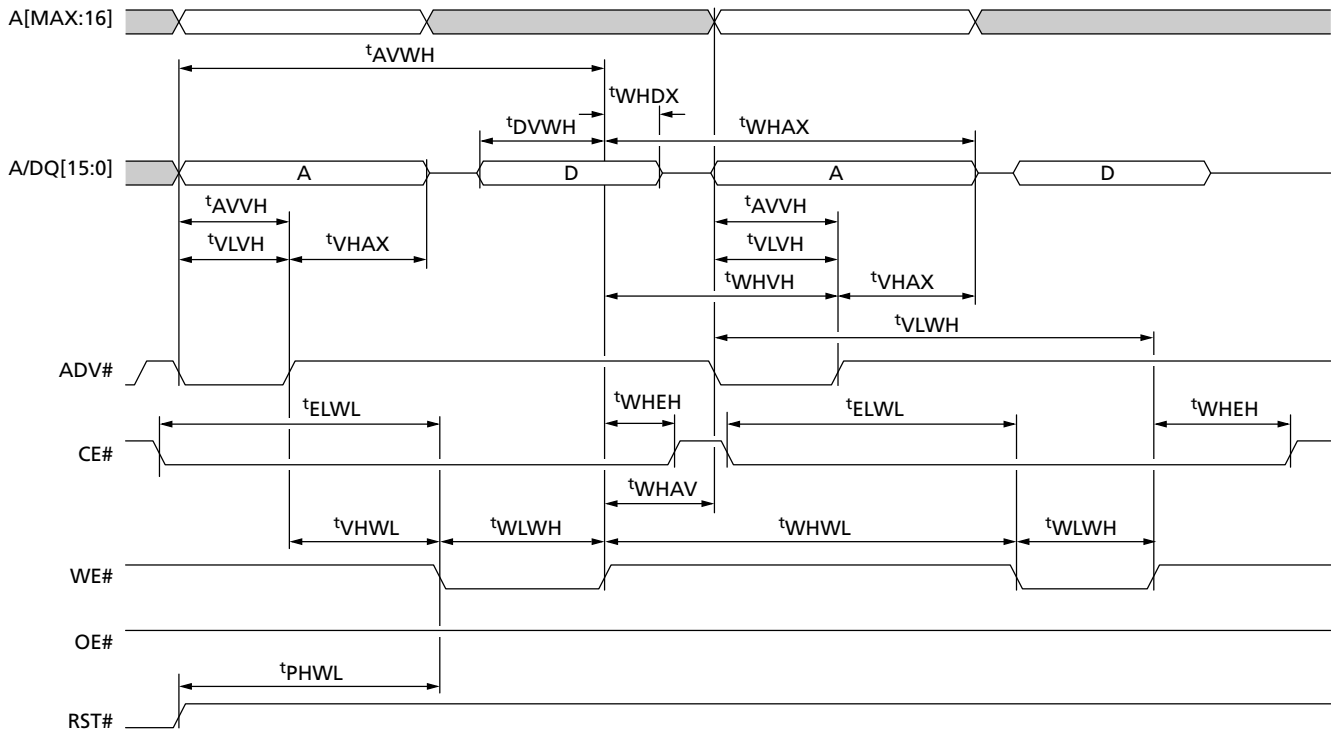

Figure 28: Write to Write (Non-Mux)

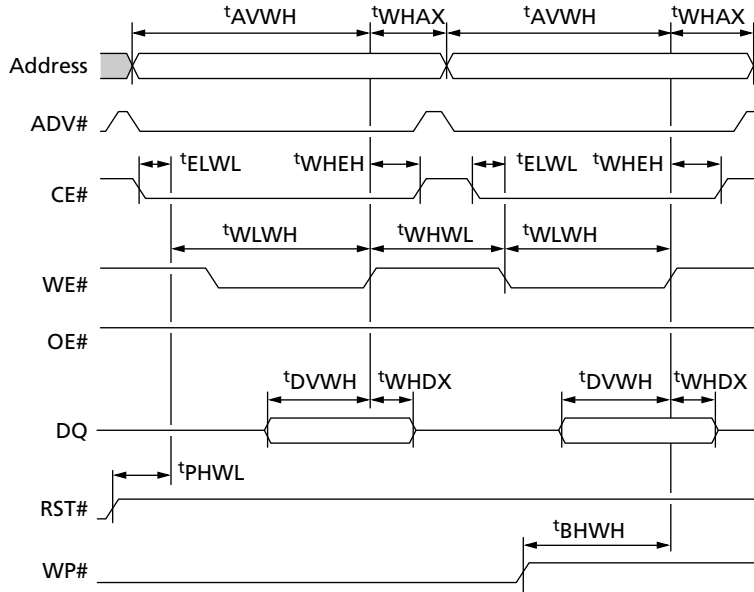

Figure 29: Async Read to Write (Non-Mux)

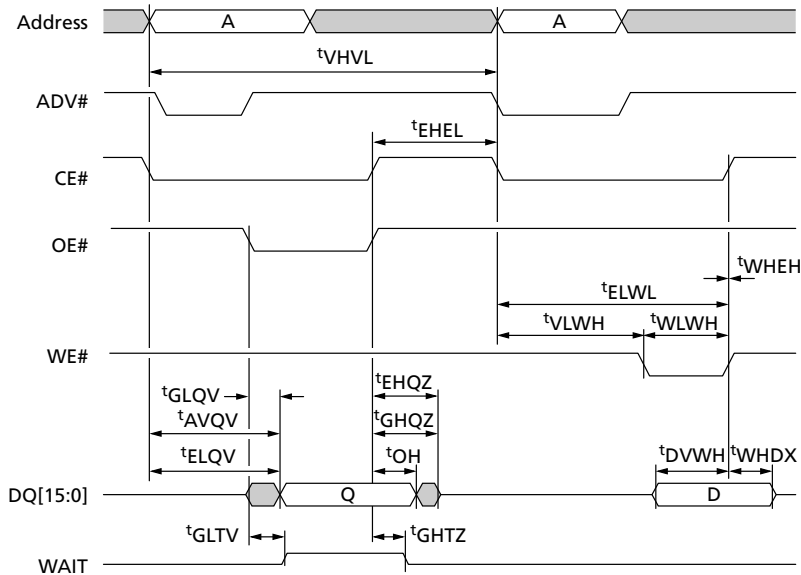

Figure 30: Write to Async Read (Non-Mux)

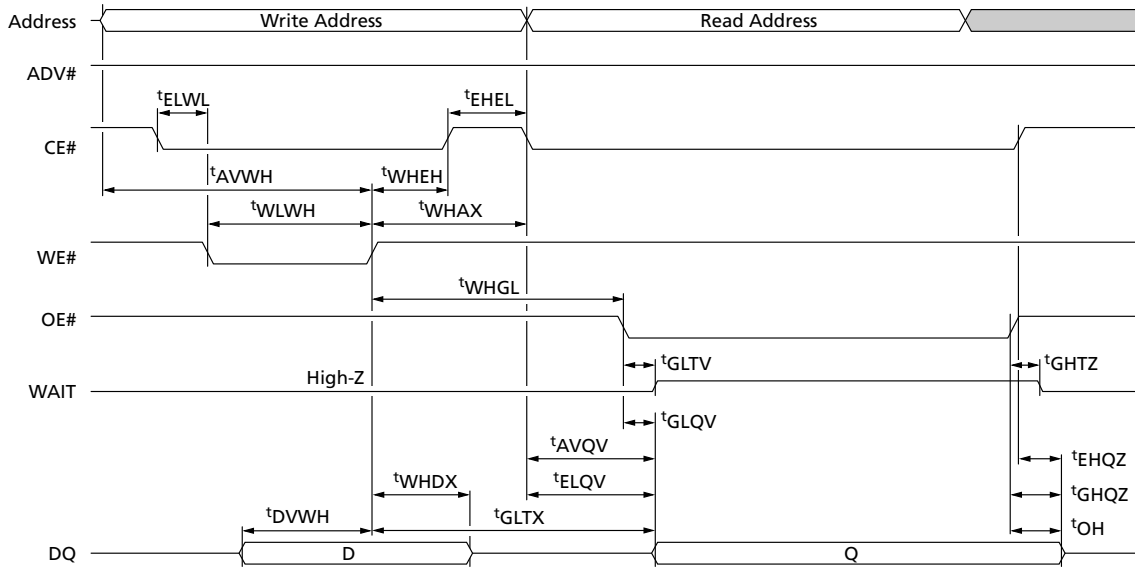

Figure 31: Sync Read to Write (Non-Mux)

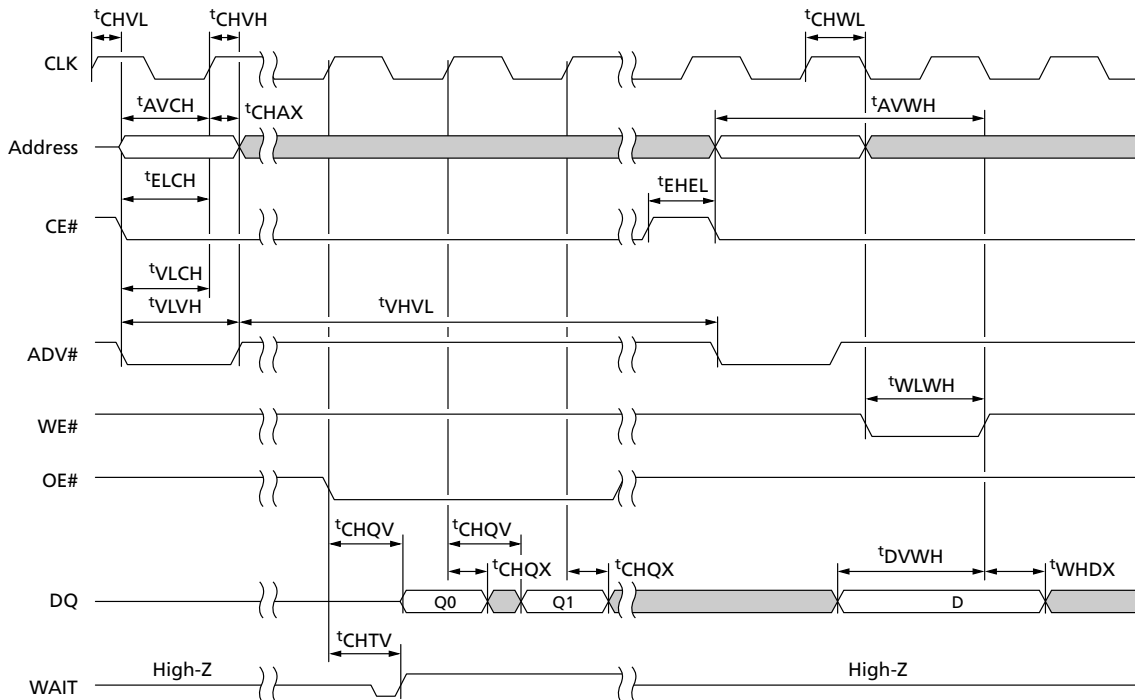

Figure 32: Write to Sync Read (Non-Mux)

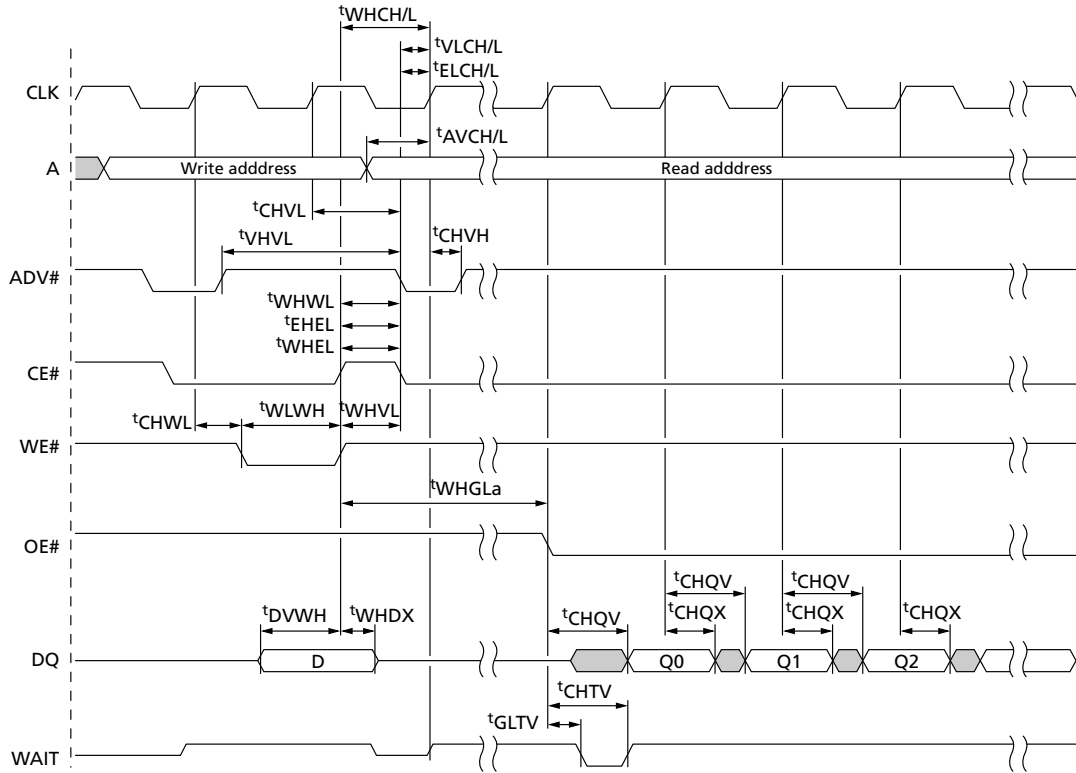

Figure 33: Write to Write (AD-Mux)

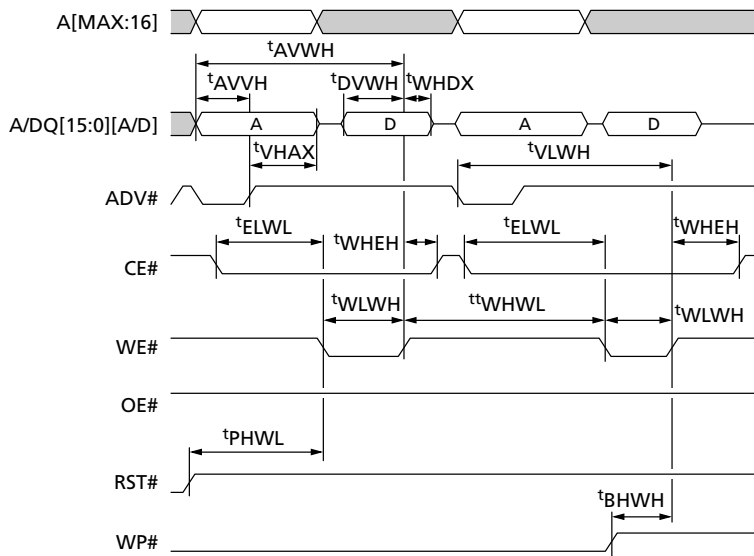

Figure 34: Async Read to Write (AD-Mux)

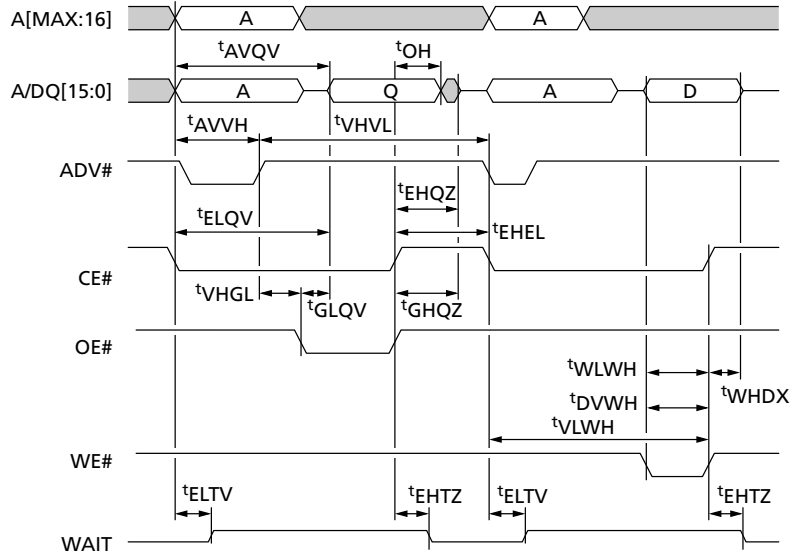

Figure 35: Write to Async Read (AD-Mux)

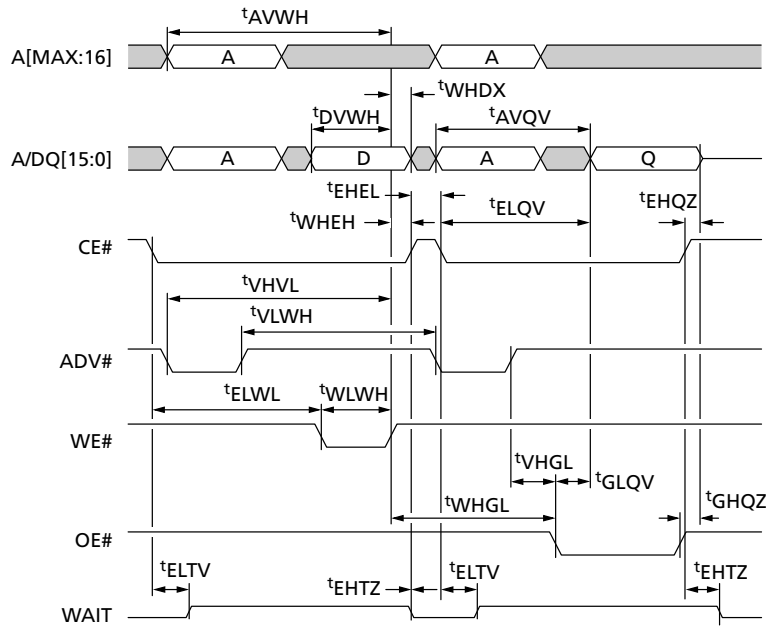

Figure 36: Sync Read to Write (AD-Mux)

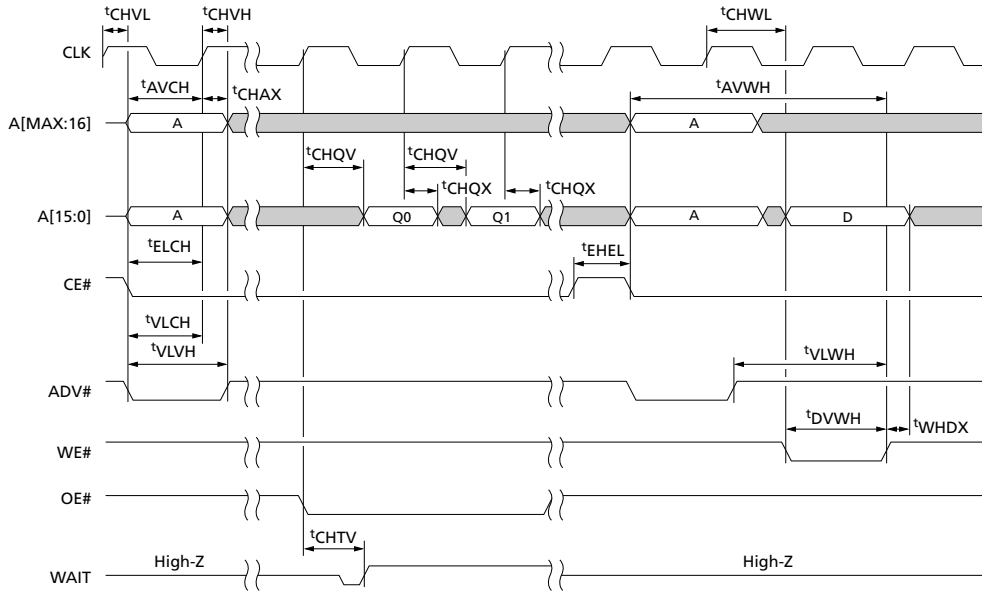
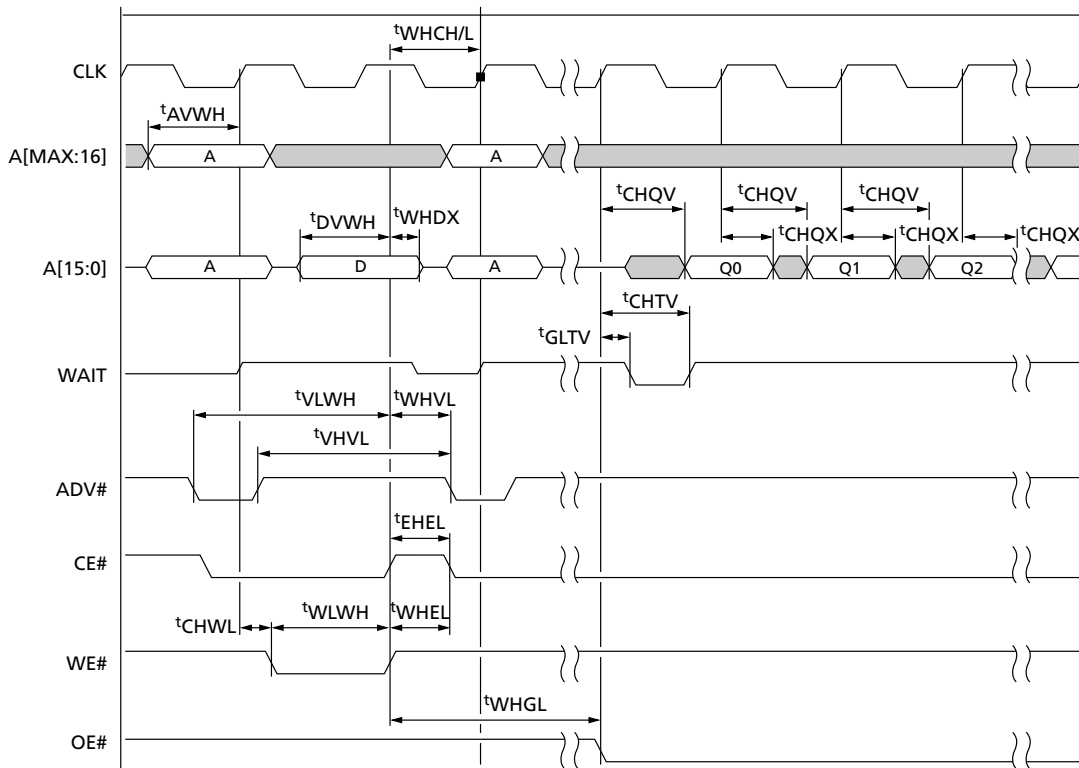

Figure 37: Write to Sync Read (AD-Mux)





Electrical Specifications – Program/Erase Characteristics

Table 42: Program/Erase Characteristics

Note 1 applies to all

Parameter		Symbol	V _{PPL} or V _{PPH}			Units	Notes	
			Min	Typ	Max			
Word Programming								
Program time	Single word (first word)		^t PROG/W	–	115	230	μs	2
	Single word (subsequent word)				50	230		
Buffered Programming								
Program time	Single word		^t PROG/W	–	250	500	μs	
	One buffer (512 words)	90nm (128–512Mb)	^t PROG/PB	–	2.15	4.3	ms	
		65nm (128–1024Mb)			1.02	2.05		
		45nm (128–1024Mb)			0.57	1.14		
Buffer Enhanced Factory Programming (BEFP)								
Program	Single word	90nm (128–512Mb)	^t BEFP/W	–	4.2	–	μs	3
		65nm (128–1024Mb)			2.0			
		45nm (128–1024Mb)			0.93			
	BEFP setup			^t BEFP/SETUP	5	–	–	μs
Erasing and Suspending								
Erase time	128K-word parameter		^t ERS/MAB	–	0.9	4	s	
Suspend latency	Program suspend		^t SUSP/P	–	20	30	μs	
	Erase suspend		^t SUSP/E	–	20	30	μs	
Blank Check								
Main array block	Main array block		^t BC/MB	–	3.2	–	ms	

- Notes:
1. Typical values measured at T_C = 25°C and nominal voltages. Performance numbers are valid for all speed versions. Excludes overhead. Sampled, but not 100% tested.
 2. Conventional word programming: First and subsequent words refer to first word and subsequent words in control mode programming region.
 3. Averaged over the entire device. BEFP is not validated at V_{PPL}.

Common Flash Interface

The common Flash interface (CFI) is part of an overall specification for multiple command set and control interface descriptions. System software can parse the CFI database structure to obtain information about the device, such as block size, density, bus width, and electrical specifications. The system software determines which command set to use to properly perform a WRITE, BLOCK ERASE, or READ command, and to otherwise control the device. Information in the CFI database can be viewed by issuing the READ CFI command.

READ CFI Structure Output

The READ CFI command obtains CFI database structure information and always outputs it on the lower byte, DQ[7:0], for a word-wide (x16) Flash device. This CFI-compliant device always outputs 00h data on the upper byte (DQ[15:8]).

The numerical offset value is the address relative to the maximum bus width that the device supports, with a starting address of 010h, which is a word address for x16 devices. For example, at a starting address of 10h, a READ CFI command outputs an ASCII Q in the lower byte and 00h in the higher byte.

In the following tables, address and data are represented in hexadecimal notation. In addition, because the upper byte of word-wide devices is always 00h, the leading 00 has been dropped and only the lower byte value is shown.

Table 43: Example of CFI Output (x16 Device) as a Function of Device and Mode

Device	Hex Offset	Hex Code	ASCII Value (DQ[15:8])	ASCII Value (DQ[7:0])
Address	00010:	51	00	Q
	00011:	52	00	R
	00012:	59	00	Y
	00013:	P_ID _{LO}	00	Primary vendor ID
	00014:	P_ID _{HI}	00	
	00015:	P _{LO}	00	Primary vendor table address
	00016:	P _{HI}	00	
	00017:	A_ID _{LO}	00	Alternate vendor ID
	00018:	A_ID _{HI}	00	
		:	:	:
	:	:	:	:

Table 44: CFI Database: Addresses and Sections

Address	Section Name	Description
00001:Fh	Reserved	Reserved for vendor-specific information
00Address010h	CFI ID string	Command set ID (identification) and vendor data offset
0001Bh	System interface information	Timing and voltage
00027h	Device geometry definition	Layout

Table 44: CFI Database: Addresses and Sections (Continued)

Address	Section Name	Description
P	Primary Micron-specific extended query	Vendor-defined informaton specific to the primary vendor algorithm (offset 15 defines <i>P</i> which points to the primary Micron-specific extended query table)

CFI ID String

The CFI ID string provides verification that the device supports the CFI specification. It also indicates the specification version and supported vendor-specific command sets.

Table 45: CFI ID String

Hex Offset	Length	Description	Address	Hex Code	ASCII Value (DQ[7:0])
10h	3	Query unique ASCII string "QRY"	10:	- -51	Q
			11:	- -52	R
			12:	- -59	Y
13h	2	Primary vendor command set and control interface ID code;16-bit ID code for vendor-specified algorithms	13:	- -00	Primary vendor ID number
			14:	- -02	
15h	2	Extended query table primary algorithm address	15:	- -0A	Primary vendor table address, primary algorithm
			16:	- -01	
17h	2	Alternate vendor command set and control interface ID code; 0000h indicates no second vendor-specified algorithm exists	17:	- -00	Alternate vendor ID number
			18:	- -00	
19h	2	Secondary algorithm extended query table address; 0000h indicates none exists	19:	- -00	Primary vendor table address, secondary algorithm
			1A:	- -00	

System Interface Information

Table 46: System Interface Information

Hex Offset	Length	Description	Address	Hex Code	ASCII Value (DQ[7:0])
1Bh	1	V _{CC} logic supply minimum program/erase voltage bits 0–3 BCD 100mV bits 4–7 BCD volts	1Bh	- -17	1.7V
1Ch	1	V _{CC} logic supply maximum program/erase voltage bits 0–3 BCD 100mV bits 4– 7 BCD volts	1Ch	- -20	2.0V
1Dh	1	V _{PP} [programming] supply minimum program/erase voltage bits 0–3 BCD 100mV bits 4–7 hex volts	1Dh	- -85	8.5V

Table 46: System Interface Information (Continued)

Hex Offset	Length	Description	Address	Hex Code	ASCII Value (DQ[7:0])
1Eh	1	V _{PP} [programming] supply maximum program/erase voltage bits 0–3 BCD 100mV bits 4–7 hex volts	1Eh	- -95	9.5V
1Fh	1	n such that typical single word program timeout = $2^n \mu\text{s}$	1Fh	- -06	64 μs
20h	1	n such that typical full buffer write timeout = $2^n \mu\text{s}$	20h	- -0B (256, 512 Mbit - 90nm; 1024 Mbit - 65nm) - -0A (128, 256, 512 Mbit - 65nm)	2048 μs (256, 512 Mbit - 90nm; 1024 Mbit - 65nm) 1023 μs (128, 256, 512 Mbit - 65nm)
21h	1	n such that typical block erase timeout = 2^nms	21h	- -0A	1s
22h	1	n such that typical full chip erase timeout = 2^nms	22h	- -00	NA
23h	1	n such that maximum word program timeout = 2^n times typical	23h	- -02	256 μs
24h	1	n such that maximum buffer write timeout = 2^n times typical	24h	- -02 (256, 512 Mbit - 90nm; 128, 256, 512 Mbit - 65nm) - -01 (1024 Mbit - 65nm)	8192 μs (256, 512 Mbit - 90nm; 128, 256, 512 Mbit - 65nm) 4096 μs (1024 Mbit - 65nm)
25h	1	n such that maximum block erase timeout = 2^n times typical	25h	- -02	4s
26h	1	n such that maximum chip erase timeout = 2^n times typical	26h	- -00	NA

Device Geometry Definition

Table 47: Device Geometry

Hex Offset	Length	Description	Address	Hex Code	ASCII Value (DQ[7:0])
27h	1	n such that device size in bytes = 2^n .	27:		(page 0)

Table 47: Device Geometry (Continued)

Hex Offset	Length	Description	Address	Hex Code	ASCII Value (DQ[7:0])
28h	2	Flash device interface code assignment: n such that $n + 1$ specifies the bit field that represents the device width capabilities as described here: bit 0: x8 bit 1: x16 bit 2: x32 bit 3: x64 bits 4–7: – bits 8–15: –	28:	- -01	x16
			29:	- -00	
2Ah	2	n such that maximum number of bytes in write buffer = 2^n	2Ah	- -0A	1024
			2Bh	- -00	
2Ch	1	Number of erase block regions (x) within the device: $x = 0$ indicates no erase blocking; the device erases in bulk x specifies the number of device regions with one or more contiguous, same-size erase blocks Symmetrically blocked partitions have one blocking region	2Ch		(page 0)
2Dh	4	Erase block region 1 information: bits 0–15 = y , $y + 1$ = number of identical-size erase blocks bits 16–31 = z , region erase block(s) size are $z \times 256$ bytes	2D:		(page 0)
			30:		
31h	4	Erase block region 2 information: bits 0–15 = y , $y + 1$ = number of identical-size erase blocks bits 16–31 = z , region erase block(s) size are $z \times 256$ bytes	31:		(page 0)
			34:		
35h	4	Reserved for future erase block region information	35:		(page 0)
			38:		

Note: 1. See the bit field table.

Table 48: Block Region Map Information

Address	128Mb		256Mb		512Mb		1Gb	
	Bottom	Top	Bottom	Top	Bottom	Top	Bottom	Top
27:	- -18	--	- -19	--	- -1A	--	- -1B	--
28:	- -01	--	- -01	--	- -01	--	- -01	--
29:	- -00	--	- -00	--	- -00	--	- -00	--
2A:	- -0A	--	- -0A	--	- -0A	--	- -0A	--
2B:	- -00	--	- -00	--	- -00	--	- -00	--
2C:	- -01	--	- -01	--	- -01	--	- -01	--



Table 48: Block Region Map Information (Continued)

Address	128Mb		256Mb		512Mb		1Gb	
	Bottom	Top	Bottom	Top	Bottom	Top	Bottom	Top
2D:	--FF	--	--7F	--	--FF	--	--FF	--
2E:	--00	--	--00	--	--00	--	--01	--
2F:	--00	--	--00	--	--00	--	--00	--
30:	--04	--	--04	--	--04	--	--04	--

Primary Micron-Specific Extended Query

Table 49: Primary Micron-Specific Extended Query

Hex Offset P = 10Ah	Length	Description	Address	Hex Code	ASCII Value (DQ[7:0])
(P+0)h (P+1)h (P+2)h	3	Primary extended query table, unique ASCII string: PRI	10A:	- -50	P
			10B:	- -52	R
			10C:	- -49	I
(P+3)h	1	Major version number, ASCII	10D:	- -31	1
(P+4)h	1	Minor version number, ASCII	10E:	- -34	4
(P+5)h (P+6)h (P+7)h (P+8)h	4	Optional feature and command support (1 = yes; 0 = no) Bits 10–31 are reserved; undefined bits are 0 If bit 31 = 1, then another 31-bit field of optional features follows at the end of the bit 30 field	10F:	- -E6 (Non-Mux) - -66 (A/D Mux)	-
			110:	- -07 (90nm, 65nm)	-
			111:	- -00	-
			112:	- -00	-
			Bit 0: Chip erase supported	Bit 0 = 0	No
			Bit 1: Suspend erase supported	Bit 1 = 1	Yes
			Bit 2: Suspend program supported	Bit 2 = 1	Yes
			Bit 3: Legacy lock/unlock supported	Bit 3 = 0	No
			Bit 4: Queued erase supported	Bit 4 = 0	No
			Bit 5: Instant individual block locking supported	Bit 5 = 1	Yes
			Bit 6: OTP bits supported	Bit 6 = 1	Yes
			Bit 7: Page mode read supported	Bit 7 = 0	No: A/D Mux Yes: Non-Mux
			Bit 8: Synchronous read supported	Bit 8 = 1	Yes
			Bit 9: Simultaneous operations supported	Bit 9 = 1	Yes
			Bit 10: Reserved	Bit 10 = 0	No
			Bit 30: CFI links to follow	Bit 30 = 0	No
		Bit 31: another optional features field to follow.	Bit 31 = 0	No	
(P+9)h	1	Supported functions after suspend: read array, status, query Other supported options: Bits 1–7 reserved; undefined bits are 0	113:	- -01	-
		Bit 0: Program supported after erase suspend	Bit 0 = 1	Yes	
(P+A)h (P+B)h	2	Block status register mask: Bits 2 – 3 and 6 - 15 are reserved; undefined bits are 0	114:	- -33 (90nm, 65nm)	-
			115:	-	
		Bit 0: Block lock bit status register active	Bit 0 = 1	Yes	
		Bit 1: Block lock-down bit status active	Bit 1 = 1	Yes	

Table 49: Primary Micron-Specific Extended Query (Continued)

Hex Offset P = 10Ah	Length	Description	Address	Hex Code	ASCII Value (DQ[7:0])
(P+C)h	1	V _{CC} logic supply highest performance program/erase voltage bits 0–3 BCD 100mV Bits 4–7 BCD value in volts	116:	- -18	1.8V
(P+D)h	1	V _{PP} optimum program/erase voltage Bits 0–3 BCD 100mV Bits 4–7 hex value in volts	117:	- -90	9.0V

Table 50: One Time Programmable (OTP) Space Information

Hex Offset P = 10Ah	Length	Description	Address	Hex Code	ASCII Value (DQ[7:0])
(P+E)h	1	Number of OTP block fields in JEDEC ID space. 00h indicates that 256 OTP fields are available	118:	- -02	2
(P+F)h (P+10)h (P+11)h (P+12)h	4	OTP Field 1: This field describes user-available OTP bytes. Some are preprogrammed with device-unique serial numbers. Others are user-programmable. Bits 0–15 point to the OTP lock byte (the first byte). The following bytes are factory preprogrammed and user-programmable: Bits 0–7 = lock/bytes JEDEC plane physical low address. Bits 8–15 = lock/bytes JEDEC plane physical high address. Bits 16–23 = n where 2^n equals factory-preprogrammed bytes. Bits 24–31 = n where 2^n equals user-programmable bytes.	119:	- -80	80h
			11A:	- -00	00h
			1B:	- -03	8 byte
			11C:	- -03	8 byte
(P+13)h (P+14)h (P+15)h (P+16)h	4	Protection Field 2: Bits 0–31 point to the protection register physical lock word address in the JEDEC plane. The bytes that follow are factory or user-programmable.	11D:	- -89	89h
			11E:	- -00	00h
			11F:	- -00	00h
			120:	- -00	00h
(P+17)h (P+18)h (P+19)h	3	Bits 32–39 = n where n equals factory-programmed groups (low byte). Bits 40–47 = n where n equals factory-programmed groups (high byte). Bits 48–55 = n where $2n$ equals factory-programmed bytes/groups.	121:	- -00	0
			122:	- -00	0
			123:	- -00	0

Table 50: One Time Programmable (OTP) Space Information (Continued)

Hex Offset P = 10Ah	Length	Description	Address	Hex Code	ASCII Value (DQ[7:0])
(P+1A)h	3	Bits 56–63 = n where n equals user-programmed groups (low byte). Bits 64–71 = n where n equals user-programmed groups (high byte). Bits 72–79 = n where n equals user programmable bytes/groups.	124:	--10	16
(P+1B)h			125:	--00	0
(P+1C)h			126:	--04	16

Table 51: Burst Read Informaton

Hex Offset P = 10Ah	Length	Description	Address	Hex Code	ASCII Value (DQ[7:0])
(P+1D)h	1	Page mode read capability: Bits 7–0 = n where 2^n hex value represents the number of read page bytes. See offset 28h for device word width to determine page mode data output width. 00h indicates no read page buffer.	127:	--05 (Non Mux) --00 (A/D Mux)	32 byte (Non Mux) 0 (A/D Mux)
(P+1E)h	1	Number of synchronous mode read configuration fields that follow. 00h indicates no burst capability.	128:	--03	3
(P+1F)h	1	Synchronous mode read capability configuration 1: Bits 3–7 = reserved. Bits 0–2 = n where 2^{n+1} hex value represents the maximum number of continuous synchronous reads when the device is configured for its maximum word width. A value of 07h indicates that the device is capable of continuous linear bursts that will output data until the internal burst counter reaches the end of the device's burstable address space. This fields's 3-bit value can be written directly to the RCR bits 0–2 if the device is configured for its maximum word width. See offset 28h for word width to determine the burst data output width.	129:	--02	8
(P+20)h	1	Synchronous mode read capability configuration 2.	12A:	--03	16
(P+21)h	1	Synchronous mode read capability configuration 3.	12B:	--07	Cont

Table 52: Partition and Block Erase Region Information

Hex Offset P = 10Ah		Description Optional Features and Commands	Length	Address	
Bottom	Top			Bottom	Top
(P+22)h	(P+22)h	Number of device hardware partition regions within the device: x = 0: A single hardware partition device (no fields follow). x specifies the number of device partition regions containing one or more contiguous erase block regions	1	12C:	12C:

Table 53: Partition Region 1 Information: Top and Bottom Offset/Address

Hex Offset P = 10Ah		Description Optional Features and Commands	Length	Address	
Bottom	Top			Bottom	Top
(P+23)h	(P+23)h	Data size of this Partition Region information field: (number of addressable locations, including this field).	2	12D:	12D:
(P+24)h	(P+24)h			12E:	12E:
(P+25)h (P+26)h	(P+25)h (P+26)h	Number of identical partitions within the partition region.	2	12F: 130:	12F: 130:
(P+27)h	(P+27)h	Number of PROGRAM or ERASE operations allowed in a partition: Bits 0–3 = number of simultaneous PROGRAM operations. Bits 4–7 = number of simultaneous ERASE operations.	1	131:	131:
(P+28)h	(P+28)h	Simultaneous PROGRAM or ERASE operations allowed in other partitions while a partition in this region is in program mode: Bits 0–3 = number of simultaneous program operations. Bits 4–7 = number of simultaneous ERASE operations.	1	132:	132:
(P+29)h	(P+29)h	Simultaneous PROGRAM or ERASE operations allowed in other partitions while a partition in this region is in erase mode: Bits 0–3 = number of simultaneous PROGRAM operations. Bits 4–7 = number of simultaneous ERASE operations.	1	133:	133:

Table 53: Partition Region 1 Information: Top and Bottom Offset/Address (Continued)

Hex Offset P = 10Ah		Description Optional Features and Commands	Length	Address	
Bottom	Top			Bottom	Top
(P+2A)h	(P+2A)h	Types of erase block regions in this partition region: x = 0: no erase blocking; the partition region erases in bulk. x = number of erase block regions with contiguous, same-size erase blocks. Symmetrically blocked partitions have one blocking region. Partition size = (type 1 blocks) x (type 1 block sizes) + (type 2 blocks) x (type 2 block sizes) +...+ (type n blocks) x (type n block sizes).	1	134:	134:
(P+2B)h	(P+2B)h	Partition region 1 (erase block type 1) information: Bits 0–15 = y, y+1 = number of identical-sized erase blocks in a partition. Bits 16–31 = z, where region erase block(s) size is z x 256 bytes.	4	135:	135:
(P+2C)h	(P+2C)h			136:	136:
(P+2D)h	(P+2D)h			137:	137:
(P+2E)h	(P+2E)h			138:	138:
(P+2F)h	(P+2F)h	Partition 1 (erase block type 1): Minimum block erase cycles x 1000	2	139:	139:
(P+30)h	(P+30)h			13A:	13A:
(P+31)h	(P+31)h	Partition 1 (erase block type 1) bits per cell; internal EDAC: Bits 0–3 = bits per cell in erase region Bit 4 = internal EDAC used (1 = yes, 0 = no) Bits 5–7 = reserved for future use	1	13B:	13B:
(P+32)h	(P+32)h	Partition 1 (erase block type 1) page mode and synchronous mode capabilities: Bits 0 = page mode host reads permitted (1 = yes, 0 = no) Bit 1 = synchronous host reads permitted (1 = yes, 0 = no) Bit 2 = synchronous host writes permitted (1 = yes, 0 = no) Bits 3–7 = reserved for future use	1	13C:	13C:
(P+33)h	(P+33)h	Partition 1 (Erase Block Type 1) programming region information: Bits 0 - 7 = x, 2 ^x : programming region aligned size (bytes) Bits 8 - 14 = reserved for future use Bit 15 = legacy flash operation; ignore 0:7 Bit 16 - 23 = y: control mode valid size (bytes) Bit 24 - 31 = reserved for future use Bit 32 - 39 = z: control mode invalid size (bytes) Bit 40 - 46 = reserved for future use Bit 47 = legacy flash operation (ignore 23:16 and 39:32)	6	13D:	13D:
(P+34)h	(P+34)h			13E:	13E:
(P+35)h	(P+35)h			13F:	13F:
(P+36)h	(P+36)h			140:	140:
(P+37)h	(P+37)h			141:	141:
(P+38)h	(P+38)h			142:	142:

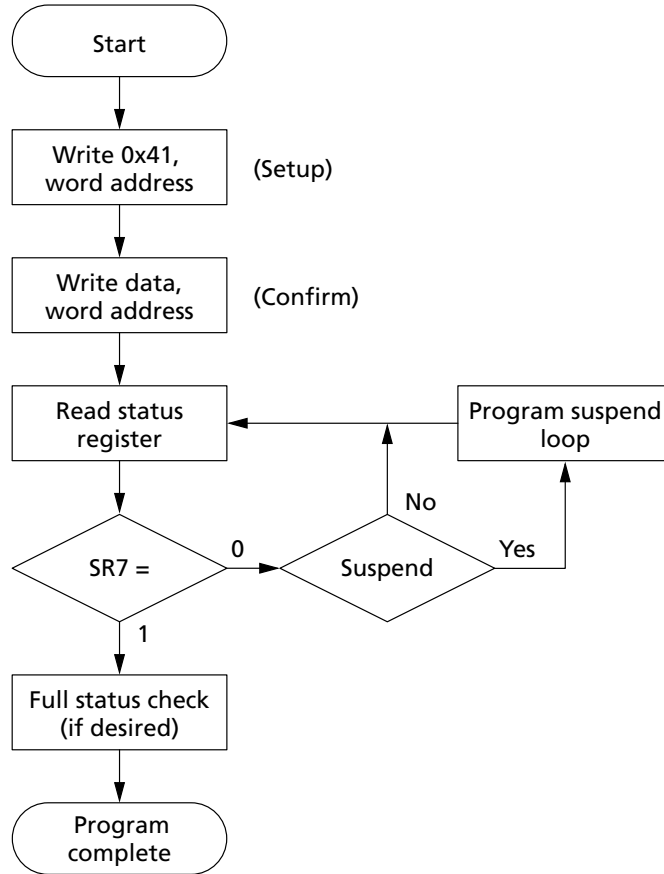

Table 54: Partition and Erase Block Map Information

Address	128Mb		256Mb		512Mb		1Gb	
	Bottom	Top	Bottom	Top	Bottom	Top	Bottom	Top
12C:	--01	--	--01	--	--01	--	--01	--
12D:	--16	--	--16	--	--16	--	--16	--
12E:	--00	--	--00	--	--00	--	--00	--
12F:	--08	--	--08	--	--08	--	--08	--
130:	--00	--	--00	--	--00	--	--00	--
131:	--11	--	--11	--	--11	--	--11	--
132:	--00	--	--00	--	--00	--	--00	--
133:	--00	--	--00	--	--00	--	--00	--
134:	--01	--	--01	--	--01	--	--01	--
135:	--07	--	--0F	--	--1F	--	--3F	--
136:	--00	--	--00	--	--00	--	--00	--
137:	--00	--	--00	--	--00	--	--00	--
138:	--04	--	--04	--	--04	--	--04	--
139:	--64	--	--64	--	--64	--	--64	--
13A:	--00	--	--00	--	--00	--	--00	--
13B:	--12	--	--12	--	--12	--	--12	--
13C:	--02 Mux --03 Non Mux	--	--02 Mux --03 Non Mux	--	--02 Mux --03 Non Mux	--	--02 Mux --03 Non Mux	--
13D:	--0A	--	--0A	--	--0A	--	--0A	--
13E:	--00	--	--00	--	--00	--	--00	--
13F:	--10	--	--10	--	--10	--	--10	--
140:	--00	--	--00	--	--00	--	--00	--
141:	--10	--	--10	--	--10	--	--10	--
142:	--00	--	--00	--	--00	--	--00	--

Flowcharts

Figure 38: Word Program Procedure



Bus Operation	Command	Comments
WRITE	PROGRAM SETUP	Data = 0x41 Address = Location to program
WRITE	DATA	Data = Data to program Address = Location to program
READ	None	Status register data
Idle	None	Check SR7 1 = Write state machine ready 0 = Write state machine busy

- Notes:
1. Repeat for subsequent word PROGRAM operations.
 2. Full status register check can be done after each program or after a sequence of PROGRAM operations.
 3. Write 0xFF after the last operation to set to the read array state.

Figure 39: Word Program Full Status Check Procedure

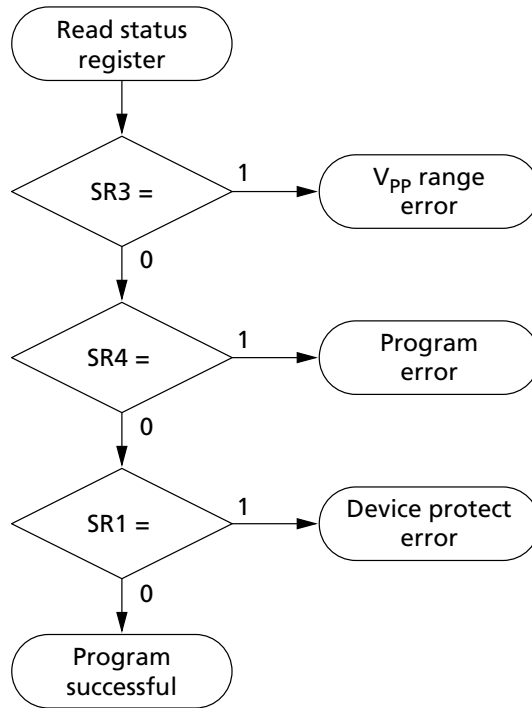

Note:

SR3 MUST be cleared before the write state machine will support further program attempts.

Bus Operation	Command	Comments
Idle	None	Check SR3 1 = V _{pp} error
Idle	None	Check SR4 1 = Data program error
Idle	None	Check SR1 1 = Block locked; operation aborted

Note: 2. If an error is detected, clear the status register before continuing operations. Only the CLEAR STATUS REGISTER command clears the status register error bits.

Figure 40: Program Suspend/Resume Procedure

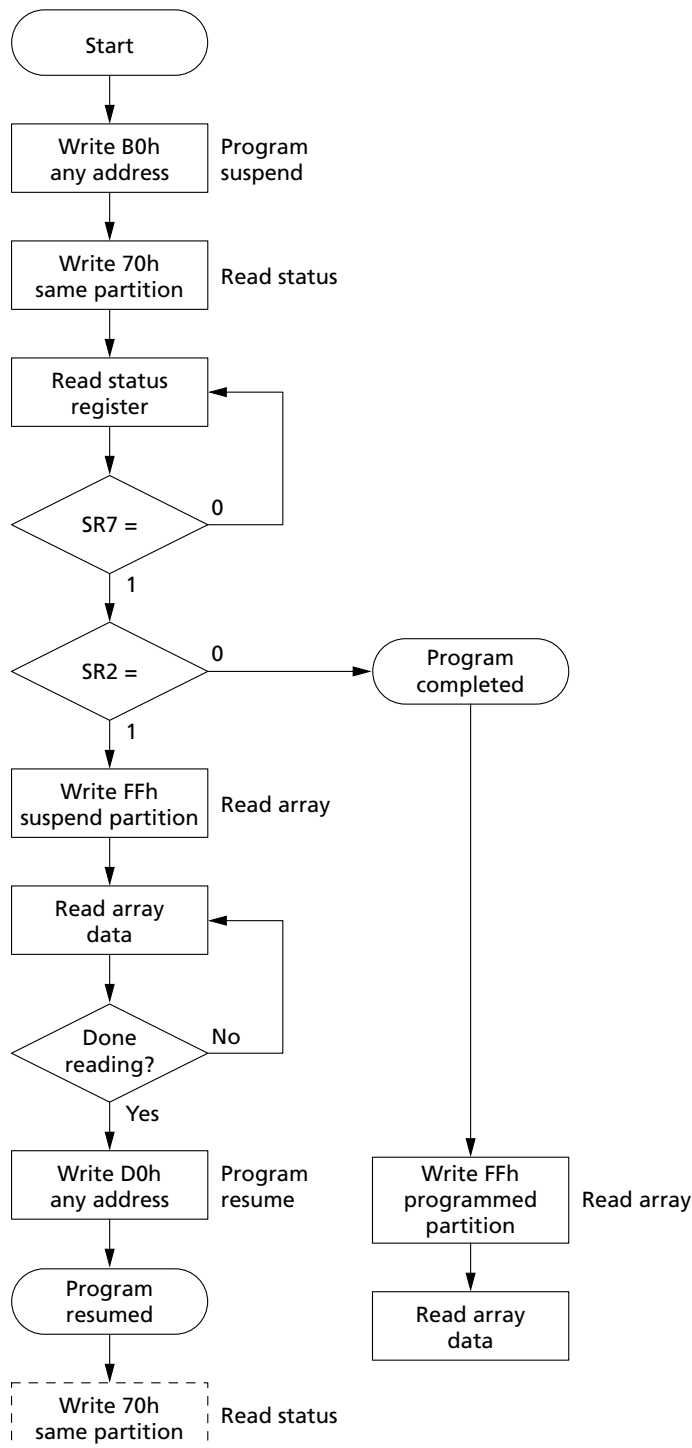



128Mb, 256Mb, 512Mb, 1Gb StrataFlash Memory Flowcharts

Bus Operation	Command	Comments
WRITE	PROGRAM SUSPEND	Data = B0h Address = Block to suspend
WRITE	READ STATUS	Data = 70h Address = Same partition
READ		Status register data Address = Suspended block
Standby		Check SR7 1 = Write state machine ready 0 = Write state machine busy
Standby		Check SR2 1 = Program suspended 0 = Program completed
WRITE	READ ARRAY	Data = FFh Address = Any address within the suspended partition
READ		Read array data from block other than the one being programmed
WRITE	PROGRAM RESUME	Data = D0h Address = Suspended block

If the suspended partition was placed in read array mode:

WRITE	READ STATUS	Return partition to status mode: Data = 70h Address = Same partition
-------	-------------	--

Figure 41: Buffer Programming Procedure

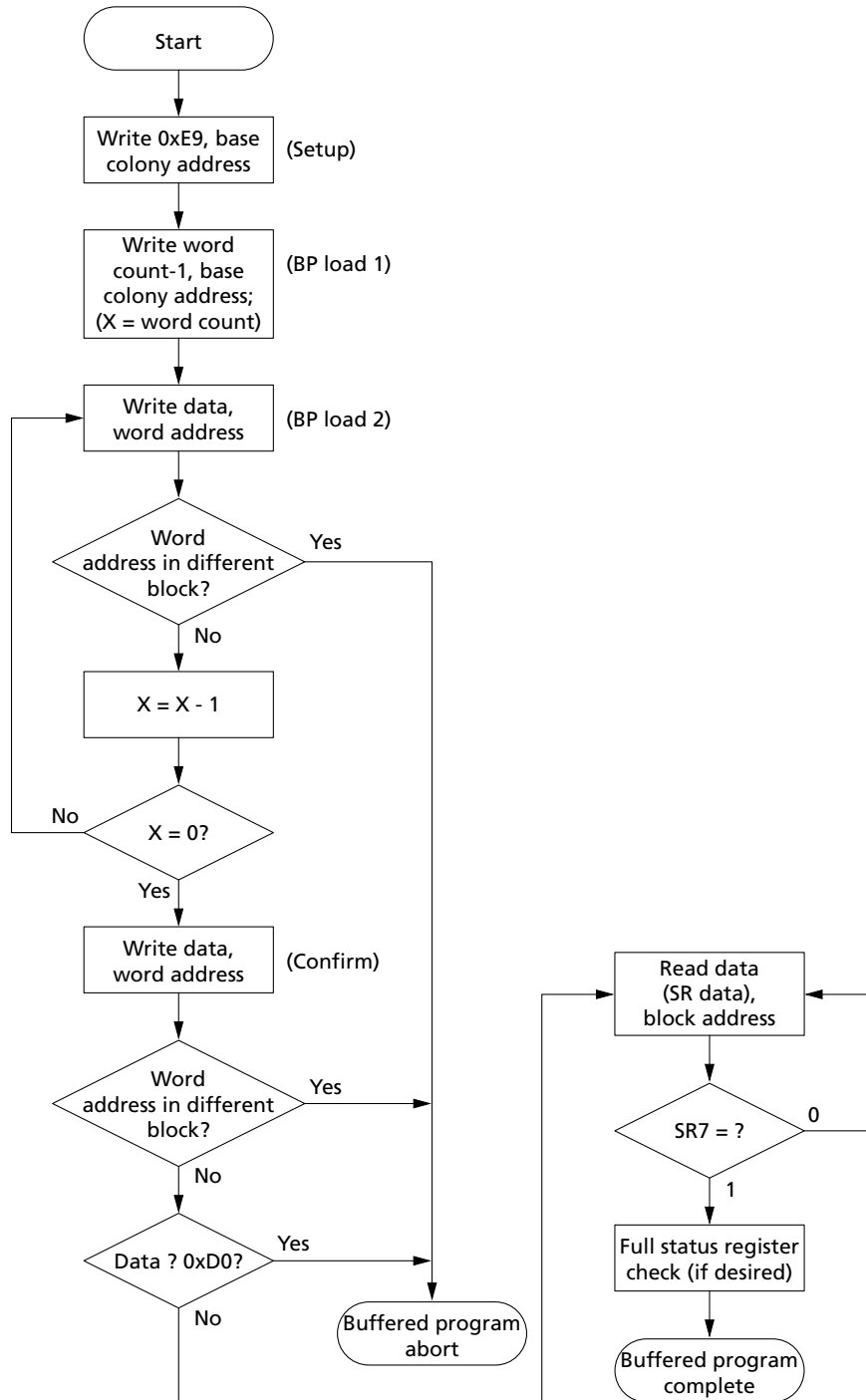

Bus Operation	Command	Comments
WRITE	BUFFERED PROGRAM SETUP	Data = 0xE9 Addr = Colony base address
WRITE	BUFFERED PROGRAM LOAD 1	Data = word count -1 ¹ Address = Block address
WRITE ^{2, 3}	BUFFERED PROGRAM LOAD 2	Data = Data to be programmed Address = Word address
WRITE ^{4, 5}	BUFFERED PROGRAM CONFIRM	Data = 0xD0 Address = Address within block
READ	None	Status register Data Address = Block address

- Notes:
1. D[8:0] is loaded as word count-1.
 2. Repeat BUFFERED PROGRAM LOAD 2 until the word count is achieved. (Load up to 512 words.)
 3. The command sequence aborts if the address of the BUFFERED PROGRAM LOAD 2 cycle is in a different block from the address of the BUFFERED PROGRAM SETUP cycle.
 4. The command sequence aborts if the address of the BUFFERED PROGRAM CONFIRM cycle is in a different block from the address of the BUFFERED PROGRAM SETUP cycle. Also, an abort will occur if the data of the BUFFERED PROGRAM CONFIRM cycle data is not 0xD0.
 5. The read mode changes to status read on the BUFFERED PROGRAM CONFIRM command.

Figure 42: Buffered Enhanced Factory Programming (BEFP) Procedure

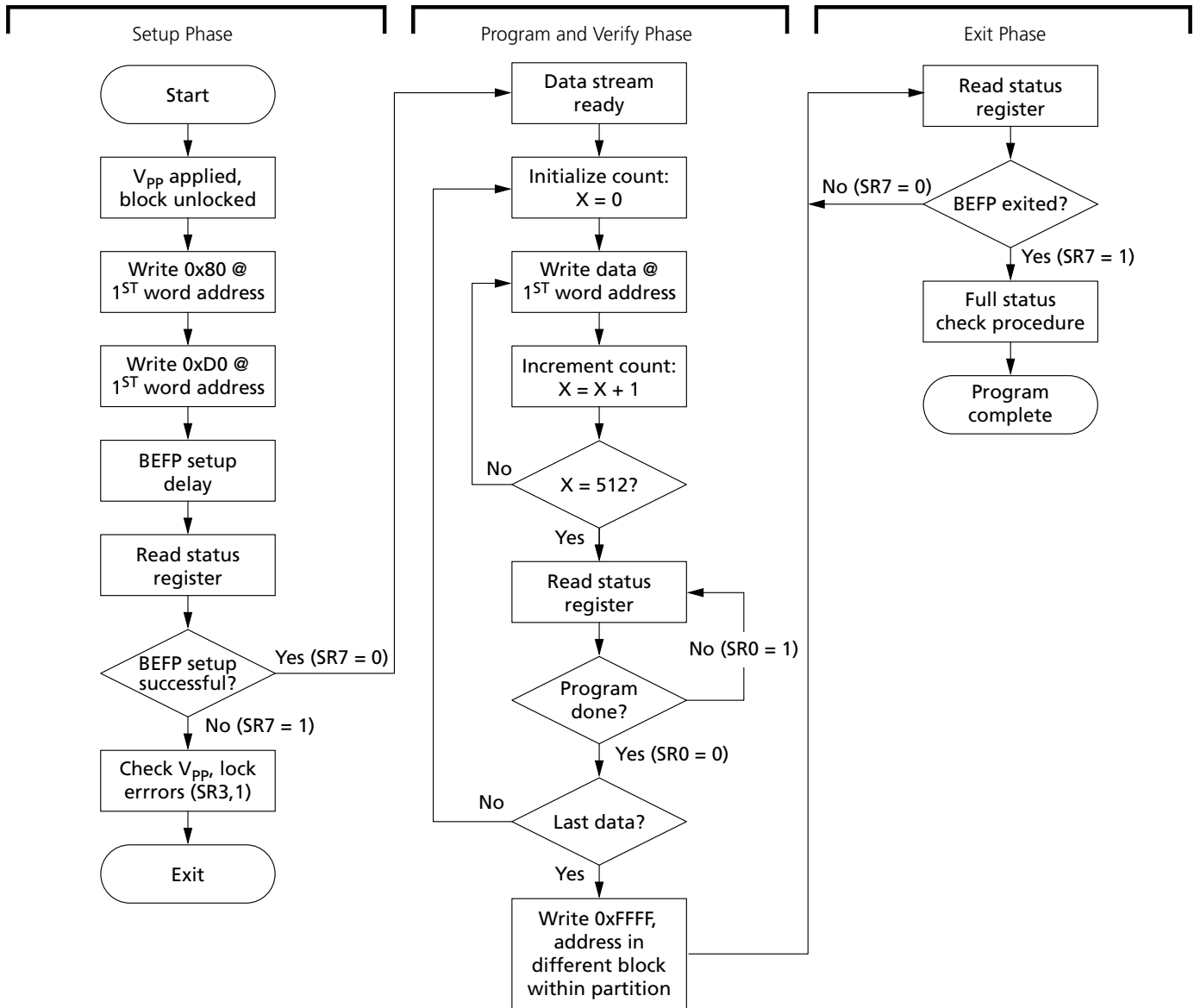

Bus Operation	Action	Comments
Setup Phase		
WRITE	Unlock block	V _{PPH} applied to V _{PP}
WRITE	BEFP setup	Data = 0x80 @ first word address ¹
WRITE	BEFP confirm	Data = 0xD0 @ first word address
READ	Status register	Data = Status register data Adress = First word address



128Mb, 256Mb, 512Mb, 1Gb StrataFlash Memory Flowcharts

Bus Operation	Action	Comments
Standby	BEFP setup done?	Check SR7: 0 = BEFP ready 1 = BEFP not ready
Standby	Error condition check	If SR7 is set, check: SR3 set = V_{pp} error SR1 set = Locked block
Program and Verify Phase		
READ	Status register	Data = Status register data Address = First word address
Standby	Data stream ready?	Check SR0: 0 = Ready for data 1 = Not ready for data
Standby	Initialize count	X = 0
WRITE	Load buffer	Data = Data to program Address = First word address ²
Standby	Increment count	X = X + 1
Standby	Buffer full?	X = 512? Yes = Read SR0 No = Load next data word
READ	Status register	Data = Status register data Address = First word address
Standby	Program done?	Check SR0: 0 = Program done 1 = Program in progress
Standby	Last data?	No = Fill buffer again Yes = Exit
WRITE	Exit program and verify phase	Data = 0xFFFF @ address not in current block
Exit Phase		
READ	Status register	Data = Status register data Address = First word address
Standby	Check exit status	Check SR7: 0 = Exit not completed 1 = Exit completed

- Notes:
1. Repeat for subsequent blocks.
 2. After BEFP exit, a full status register check can determine if any program error occurred.
 3. See the Word Program Full Status Register Check Procedure flowchart.
 4. Write 0xFF to enter read array state.

Figure 43: Block Erase Procedure

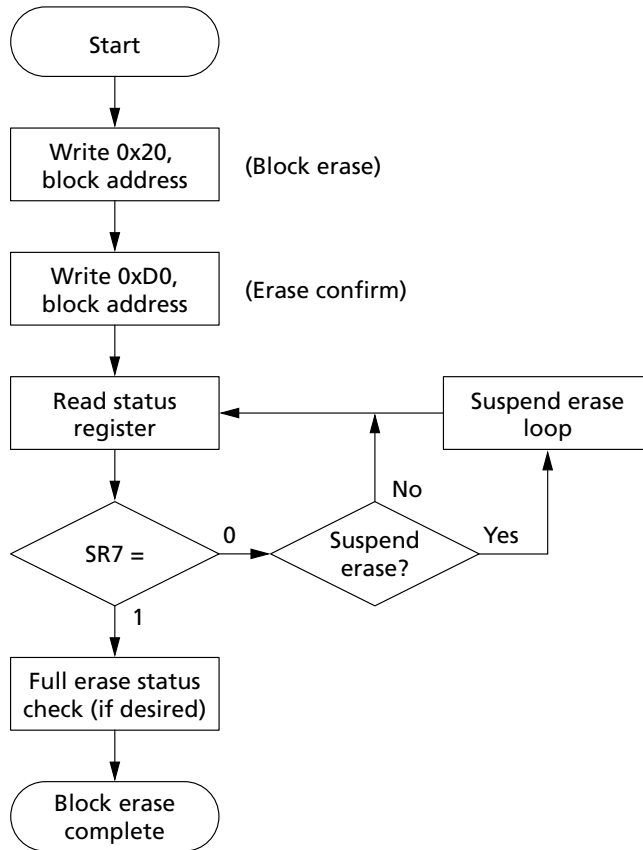

Bus Operation	Command	Comments
WRITE	BLOCK ERASE SETUP	Data = 0x20 Address = Block to be erased
WRITE	ERASE CONFIRM	Data = 0xD0 Address = Block to be erased
READ	None	Status register data
Idle	None	Check SR7 1 = Write state machine ready 0 = Write state machine busy

- Notes:
1. Repeat for subsequent block erasures.
 2. Full status register check can be done after each block erase or after a sequence of block erasures.
 3. Write 0xFF after the last operation to enter read array mode.

Figure 44: Block Erase Full Status Check Procedure

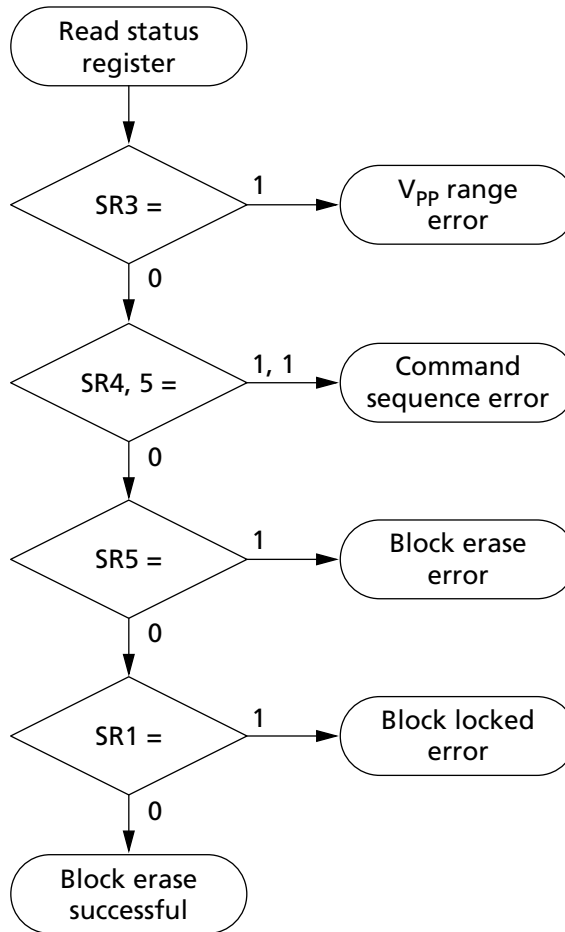

Bus Operation	Command	Comments
Idle	None	Check SR3 1 = V _{pp} range error
Idle	None	Check SR[4, 5] Both 1 = Command sequence error
Idle	None	Check SR5 1 = Block erase error
Idle	None	Check SR1 1 = Attempted erase of locked block; erase aborted

- Notes:
1. Only the CLEAR STATUS REGISTER command clears the SR[1, 3, 4, 5].
 2. If an error is detected, clear the status register before attempting an erase retry or other error recovery.

Figure 45: Erase Suspend/Resume Procedure

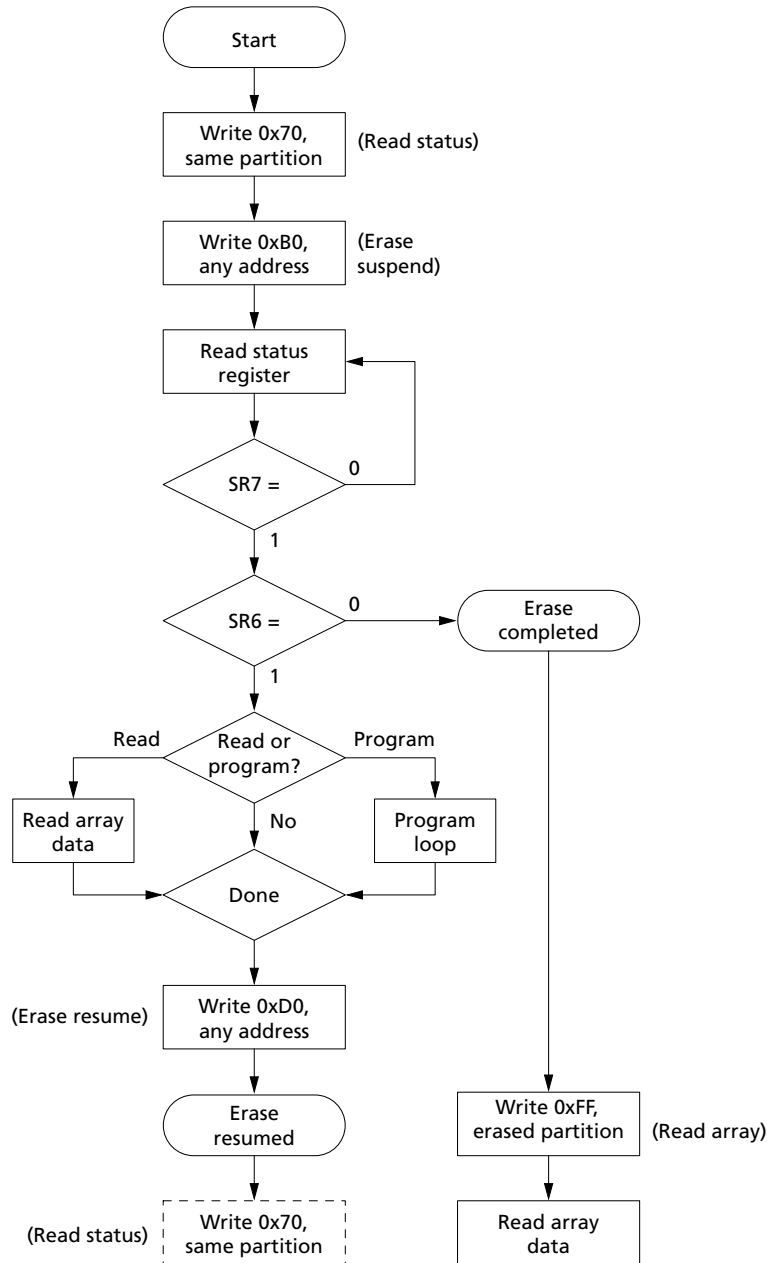



128Mb, 256Mb, 512Mb, 1Gb StrataFlash Memory Flowcharts

Bus Operation	Command	Comments
WRITE	READ STATUS	Data = 0x70 Address = Any partition address
WRITE	ERASE SUSP- PEND	Data = 0xB0 Address = Same partition address as above
READ	None	Status register data Address = Same partition
Idle	None	Check SR7 1 = Write state machine ready 0 = Write state machine busy
Idle	None	Check SR6 1 = Erase suspended 0 = Erase completed
WRITE	Any READ or PROGRAM	Data = Command for desired operation Address = Any address within the suspended partition
READ or WRITE	None	Read array or program data from/to block other than the one being erased
WRITE	PROGRAM RE- SUME	Data = 0xD0 Address = Any address

If the suspended partition was placed in read array mode or a program loop:

WRITE	READ STATUS REGISTER	Return partition to status mode: Data = 0x70 Address = Same partition
-------	-------------------------	---

Figure 46: Block Lock Operations Procedure

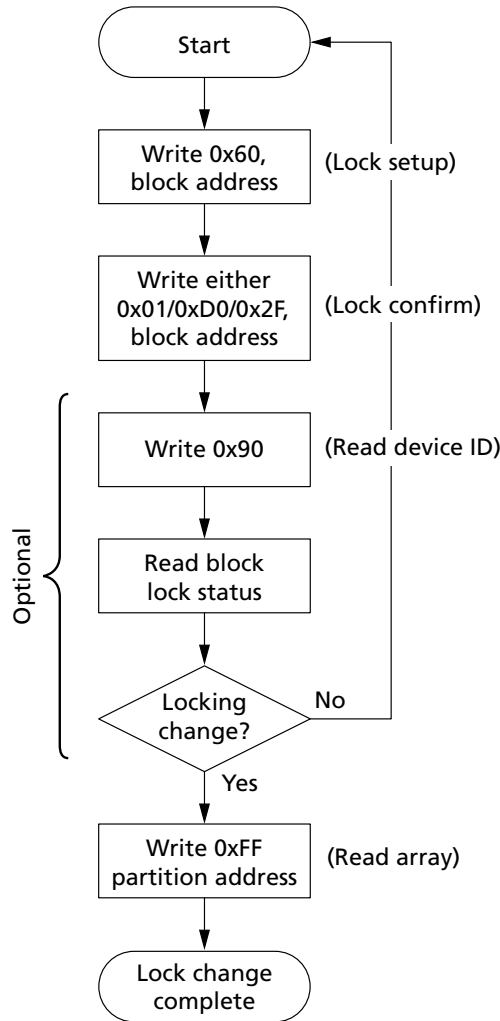

Bus Operation	Command	Comments
WRITE	LOCK SETUP	Data = 0x60 Address = Block to lock/unlock/lock-down
WRITE	LOCK, UNLOCK, or LOCK-DOWN CONFIRM	Data = 0x01 (BLOCK LOCK) Data = 0xD0 (BLOCK UNLOCK) Data = 0x2F (LOCK-DOWN BLOCK) Address = Block to lock/unlock/lock-down
WRITE (optional)	READ DEVICE ID	Data = 0x90 Address = Block address + offset 2
READ (optional)	BLOCK LOCK STATUS	Block lock status data Address = Block address + offset 2
Idle	None	Confirm locking change on D[1, 0]
WRITE	READ ARRAY	Data = 0xFF Address = Block address

Figure 47: Protection Register Programming Procedure

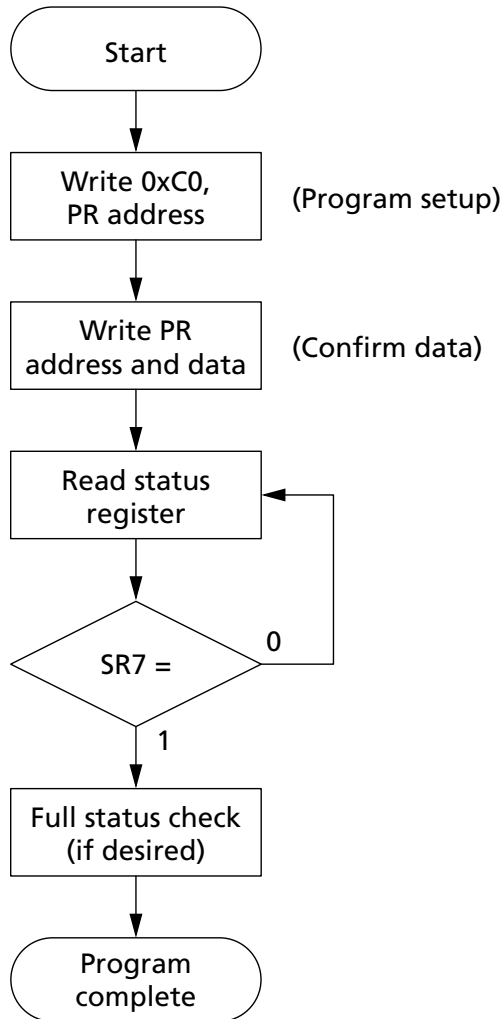

Bus Operation	Command	Comments
WRITE	PROGRAM PR SETUP	Data = 0xC0 Address = First location to program
WRITE	PROTECTION PROGRAM	Data = Data to program Address = Location to program
READ	None	Status register data
Idle	None	Check SR7 1 = Write state machine ready 0 = Write state machine busy

- Notes:
1. PROGRAM PROTECTION REGISTER operation addresses must be within the protection register address space. Addresses outside this space will return an error.
 2. Repeat for subsequent PROGRAM operations.
 3. Full status register check can be done after each PROGRAM operation or after a sequence of PROGRAM operations.
 4. Write 0xFF after the last operation to set to the read array state.

Figure 48: Protection Register Programming Full Status Check Procedure

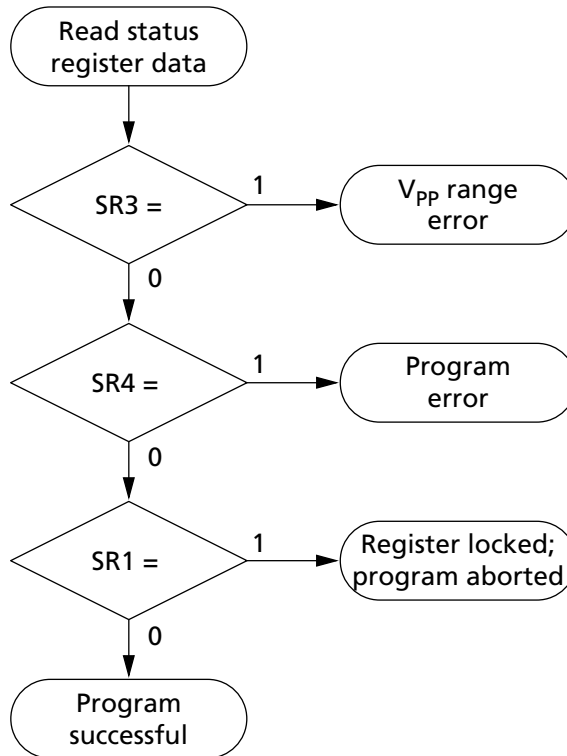

Bus Operation	Command	Comments
Idle	None	Check SR3 1 = V _{pp} error
Idle	None	Check SR4 1 = Programming error
Idle	None	Check SR1 1 = Register locked; operation aborted

- Notes:
1. Only the CLEAR STATUS REGISTER command clears SR[1, 3, 4].
 2. If an error is detected, clear the status register before attempting a program retry or other error recovery.

Figure 49: Blank Check Procedure

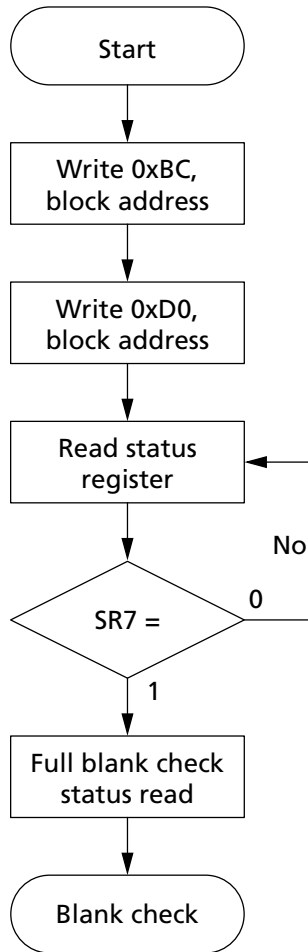

Bus Operation	Command	Comments
WRITE	BLANK CHECK SETUP	Data = 0xBC Address = Block to be read
WRITE	BLANK CHECK CONFIRM	Data = 0xD0 Address = Block to be read
READ	None	Status register data
Idle	None	Check SR7 1 = Write state machine ready 0 = Write state machine busy

- Notes:
1. Repeat for subsequent block blank check.
 2. Full status register check should be read after blank check has been performed on each block.

Figure 50: Blank Check Full Status Check Procedure

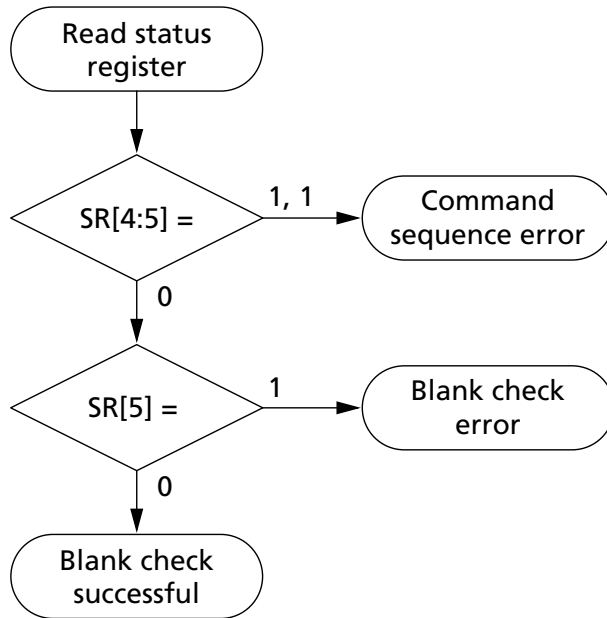

Bus Operation	Command	Comments
Idle	None	Check SR[4, 5] 1 = Command sequence error
Idle	None	Check SR5 1 = Blank check error

- Notes:
1. SR[1, 3] must be cleared before the write state machine will allow blank check to be performed.
 2. Only the CLEAR STATUS REGISTER command clears SR[1, 3, 4, 5].
 3. If an error is detected, clear the status register before attempting a blank check retry or other error recovery.

AADM Mode

AADM Feature Overview

The following is a list of general requirements for AADM mode.

Feature availability. AADM mode is available in devices that are configured as A/D MUX. With this configuration, AADM mode is enabled by setting a specific volatile bit in the read configuration register.

High-address capture (A[MAX:17]). When AADM mode is enabled, A[MAX:17] and A[16:1] are captured from the A/ DQ[15:0] balls. The selection of A[MAX:17] or A[16:1] is determined by the state of the OE# input, as A[MAX:17] is captured when OE# is at V_{IL} .

READ and WRITE cycle support. In AADM mode, both asynchronous and synchronous cycles are supported.

Customer requirements. For AADM operation, the customer is required to ground A[MAX:17].

Other characteristics. For AADM, all other device characteristics (program time, erase time, I_{CCS} , etc.) are the same as A/D MUX unless otherwise stated.

AADM Mode Enable (RCR[4] = 1)

Setting RCR[4] to its non-default state (1b) enables AADM mode. The default device configuration upon reset or power-up is A/D MUX mode. Upon setting RCR[4] = 1, the upper addresses, A[MAX:17] are latched. All 0s are latched by default.

Bus Cycles and Address Capture

AADM bus operations have one or two address cycles. For two address cycles, the upper address (A[MAX:17]) must be issued first, followed by the lower address (A[16:1]). For bus operations with only one address cycle, only the lower address is issued. The upper address that applies is the one that was most recently latched on a previous bus cycle. For all READ cycles, sensing begins when the lower address is latched, regardless of whether there are one or two address cycles.

In bus cycles, the external signal that distinguishes the upper address from the lower address is OE#. When OE# is at V_{IH} , a lower address is captured; when OE# is at V_{IL} , an upper address is captured.

When the bus cycle has only one address cycle, the timing waveform is similar to A/D MUX mode. The lower address is latched when OE# is at V_{IH} , and data is subsequently outputted after the falling edge of OE#.

When the device initially enters AADM mode, the upper address is internally latched as all 0s.

WAIT Behavior

The WAIT behavior in AADM mode functions the same as the legacy non-MUX WAIT behavior (A/D MUX WAIT behavior is unique). In other words, WAIT will always be driven whenever DQ[15:0] is driven, and WAIT will tri-state whenever DQ[15:0] tri-state.

In asynchronous mode (RCR[15] = 1b), WAIT always indicates valid data when driven. In synchronous mode (RCR[15] = 0b), WAIT indicates valid data only after the latency count has lapsed and the data output data is truly valid.

Asynchronous READ and WRITE Cycles

For asynchronous READ and WRITE cycles, ADV# must be toggled HIGH-LOW-HIGH a minimum of one time and a maximum of two times during a bus cycle. If ADV# is toggled LOW twice during a bus cycle, OE# must be held LOW for the first ADV# rising edge and OE# must be held HIGH for the second ADV# rising edge. The first ADV# rising edge (with OE# LOW) captures A[MAX:16]. The second ADV# rising edge (with OE# HIGH) captures A[16:1]. Each bus cycle must toggle ADV# HIGH-LOW-HIGH at least one time in order to capture A[16:1]. For asynchronous reads, sensing begins when the lower address is latched.

During asynchronous cycles, it is optional to capture A[MAX:17]. If these addresses are not captured, then the previously captured A[MAX:17] contents will be used.

Asynchronous READ Cycles

For AADM, note that asynchronous read access is from the rising edge of ADV# rather than the falling edge (^tVHQV rather than ^tVLQV).

Table 55: AADM Asynchronous and Latching Timings

Symbol	MIN (ns)	MAX (ns)	Notes
^t GLQV		20	
^t PHQV		150	
^t ELQX	0		
^t GLQX	0		
^t EHQZ		9	
^t GHQZ		9	
^t OH	0		
^t EHEL	7		
^t ELTV		11	
^t EHTZ		9	
^t GLTV		7	
^t GLTX	0		
^t GHTZ		9	
^t AVVH	5		
^t ELVH	9		
^t VLVH	7		
^t VHVL	7		
^t VHAX	5		
^t VHGL	3		
^t VHQV		96	1
^t PHVH	30		

- Without latching A[MAX:17] in the asynchronous READ cycle, the previously latched A[MAX:17] applies.

Asynchronous WRITE Cycles

Table 56: AADM Asynchronous Write Timings

Symbol	MIN (ns)
t_{PHWL}	150
t_{ELWL}	0
t_{WLWH}	40
t_{DVWH}	40
t_{WHEH}	0
t_{WHDX}	0
t_{WHWL}	20
t_{VPWH}	200
t_{WVVL}	0
t_{BHWH}	200
t_{WHGL}	0
t_{GHWL}	0

- Notes:
- A READ cycle may be restarted prior to completing a pending READ operation, but this may occur only once before the sense operation is allowed to complete.
 - t_{VHQV} applies to asynchronous read access time.

Figure 53: AADM Asynchronous WRITE Cycle (Latching A[MAX:0])

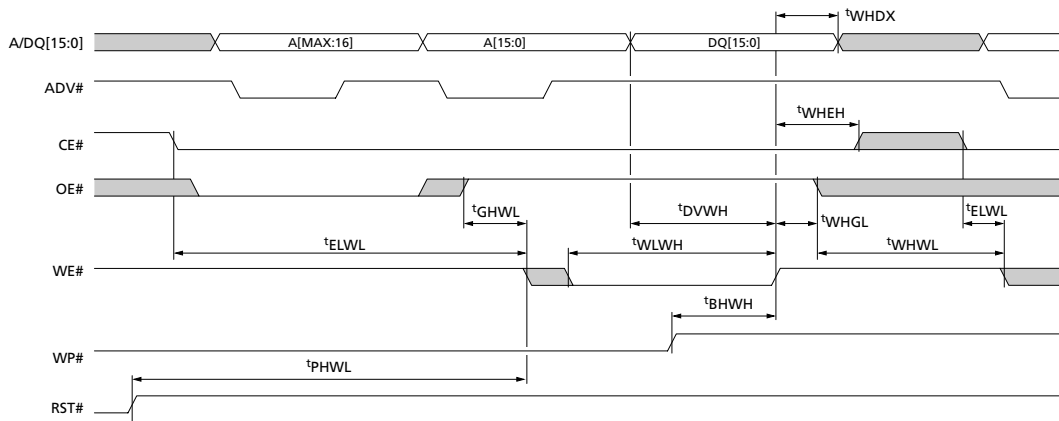

- Note: 1. CE# need not be de-asserted at beginning of cycle if OE# does not have output control.

Figure 54: AADM Asynchronous WRITE Cycle (Latching A[15:0] only)

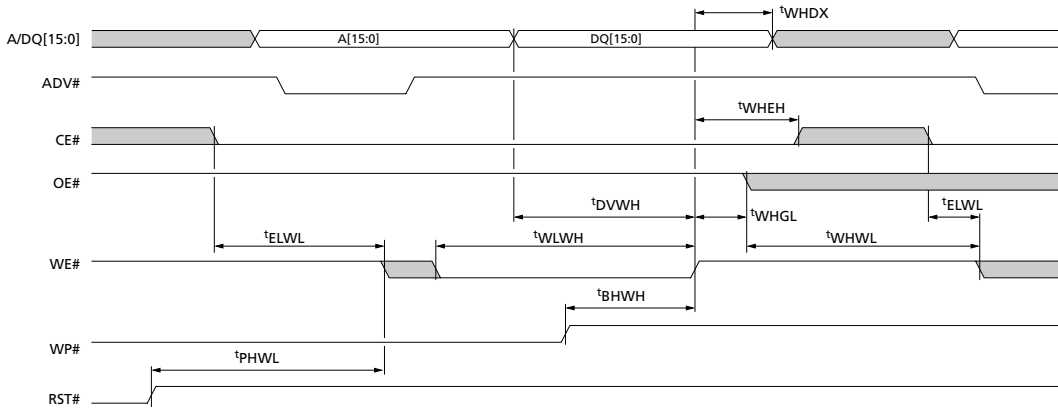

Note: 1. Without latching A[MAX:16] in the WRITE cycle, the previously latched A[MAX:16] applies.

Synchronous READ and WRITE Cycles

Just as asynchronous bus cycles, synchronous bus cycles (RCR[15] = 0b) can have one or two address cycles. If there are two address cycles, the upper address must be latched first with OE# at V_{IL} followed by the lower address with OE# at V_{IH}. If there is only one address cycle, only the lower address will be latched and the previously latched upper address applies. For reads, sensing begins when the lower address is latched, but for synchronous reads, addresses are latched on a rising clock CLK instead of a rising ADV# edge.

For synchronous bus cycles with two address cycles, it is not necessary to de-assert ADV# between the two address cycles. This allows both the upper and lower address to be latched in only two clock periods.

Synchronous READ Cycles

For synchronous READ operation, the specifications in the AADM Asynchronous and Latching Timings Table also apply.

Table 57: AADM Synchronous Timings

Symbol	Target (104 MHz) Min (ns)	Target (104 MHz) Max (ns)	Notes
t _{CLK}	9		
t _{RISE/FALL}		1.5	6
t _{AVCH}	3		
t _{VLCH}	3		
t _{ELCH}	3.5		
t _{CHQV}		7	
t _{CHQX}	2		
t _{CHAX}	5		5

Table 57: AADM Synchronous Timings (Continued)

Symbol	Target (104 MHz) Min (ns)	Target (104 MHz) Max (ns)	Notes
t_{CHTV}		7	
t_{CHVL}	2.5		
t_{CHTX}	2		
t_{CHVH}	2		
t_{CHGL}	2.5		4, 5
t_{VLVH}	t_{CLK}	$2 \times t_{CLK}$	3, 4
t_{VHCH}	3		
t_{CHGH}	2		
t_{GHCH}	2		
t_{GLCH}	3		

- Notes:
1. In synchronous burst READ cycles, the asynchronous OE# to ADV# setup and hold times must also be met (t_{GHVH} and t_{VHGL}) to signify that the address capture phase of the bus cycle is complete.
 2. A READ cycle may only be terminated (prior to the completion of sensing data) one time before a full bus cycle must be allowed to complete.
 3. The device must operate down to 9.6 MHz in synchronous burst mode.
 4. During the address capture phase of a read burst bus cycle, OE# timings relative to CLK shall be identical to those of ADV# relative to CLK.
 5. To prevent A/D bus contention between the host and the memory device, OE# may only be asserted LOW after the host has satisfied the ADDR hold spec, t_{CHAX} .
 6. Rise and fall time specified between V_{IL} and V_{IH} .

Figure 55: AADM Synchronous Burst READ Cycle (ADV# De-asserted Between Address Cycles)

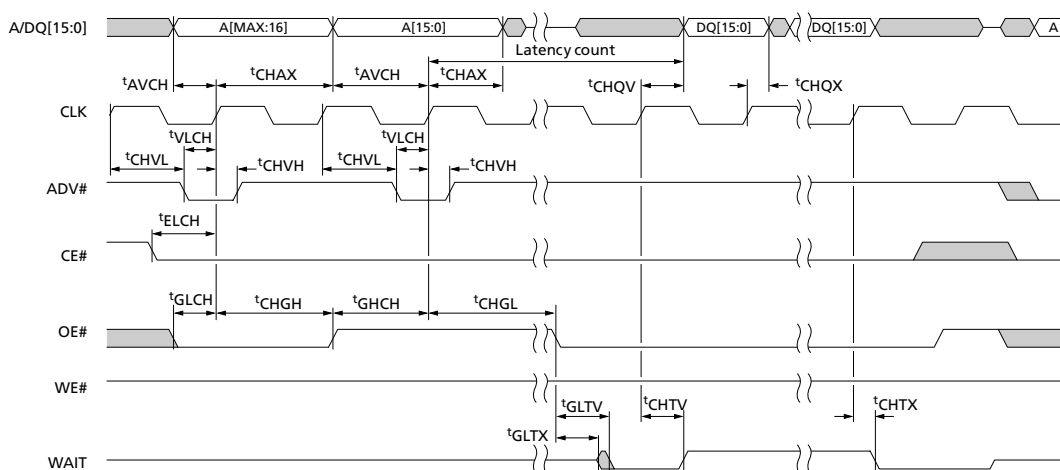

- Notes:
1. CE# need not be de-asserted at beginning of cycle if OE# does not have output control.
 2. Diagram shows WAIT as active LOW (RCR[10] = 0) and asserted with data (RCR[8] = 0).
 3. For no-wrap bursts, end-of-wordline WAIT states could occur (not shown).

Synchronous WRITE Cycles

For synchronous writes, only the address latching cycle(s) are synchronous. Synchronous address latching is depicted in the Synchronous READ Cycles.

The actual WRITE operation (rising WE# edge) is asynchronous and is independent of CLK. Asynchronous writes are depicted in Asynchronous WRITE Cycles.

System Boot

Systems that use the AADM mode will boot from the bottom 128KB of device memory because A[MAX:17] are expected to be grounded in-system. The 128KB boot region is sufficient to perform required boot activities before setting RCR[4] to enable AADM mode.

Ordering Information

Figure 58: Part Number Chart for G18 Components

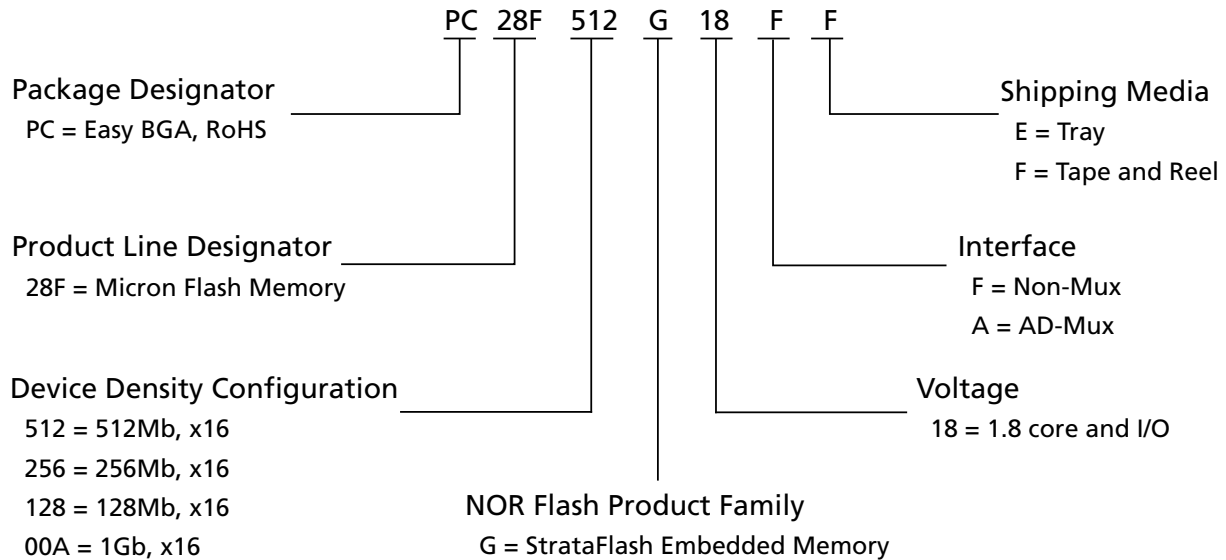

Table 58: Valid Line Items

Part Number	Density	Package	Interface	Shipping Media
PC28F128G18FE	128Mb	Easy BGA	Non-Mux	Tray
PC28F128G18FF	128Mb	Easy BGA	Non-Mux	Tape and Reel
PC28F256G18FE	256Mb	Easy BGA	Non-Mux	Tray
PC28F256G18FF	256Mb	Easy BGA	Non-Mux	Tape and Reel
PC28F256G18AE	256Mb	Easy BGA	AD-Mux	Tray
PC28F256G18AF	256Mb	Easy BGA	AD-Mux	Tape and Reel
PC28F512G18FE	512Mb	Easy BGA	Non-Mux	Tray
PC28F512G18FF	512Mb	Easy BGA	Non-Mux	Tape and Reel
PC28F00AG18FE	1Gb	Easy BGA	Non-Mux	Tray
PC28F00AG18FF	1Gb	Easy BGA	Non-Mux	Tape and Reel

Revision History

Rev. F – 8/11

- Removed (45nm, 65nm, Litho) from the Device ID Codes table.
- Changed balls H2 and H6 from V_{SS} to V_{SSQ} in Figure 2.
- Corrected A/D MUX symbol from A[MAX:16] to A[MAX:17] in the Signal Descriptions table.
- Added the Address Mapping for Address/ Data Mux Mode table.
- Updated the Read Configuration Register Bit Definitions table.

Rev. E – 8/11

- CFI ID string table, hex offset 13h: Changed address 13 hex code to 00; changed address 14 hex code to 02.
- Table: DC Voltage Characteristics and Operating Conditions: Changed V_{IL} Max to 0.45; changed V_{IH} Min to $V_{CCQ} - 0.45$.

Rev. D – 5/11

- Revised for reuse.

Rev. C – 2/11

- Added AAD-mux description.

Rev. B – 12/10

- Made miscellaneous text edits and formatting improvements.

Rev. A – 12/10

- Initial release.

8000 S. Federal Way, P.O. Box 6, Boise, ID 83707-0006, Tel: 208-368-3900
www.micron.com/productsupport Customer Comment Line: 800-932-4992
Micron and the Micron logo are trademarks of Micron Technology, Inc.
All other trademarks are the property of their respective owners.

This data sheet contains minimum and maximum limits specified over the power supply and temperature range set forth herein. Although considered final, these specifications are subject to change, as further product development and data characterization sometimes occur.

X-ON Electronics

Largest Supplier of Electrical and Electronic Components

Click to view similar products for [micron manufacturer](#):

Other Similar products are found below :

[MTFC4GACAJCN-1M WT TR](#) [MT18JSF1G72PDZ-1G6E1](#) [MTFDDAK960MAV-1AEA2AAYYES](#) [M29W400DT55N6E](#) [M25P32-VME6G](#)
[MT29F1G16ABBDAH4-ITX:D TR](#) [MTFDHAL7T6TDP-1AT1ZABYY](#) [MTFDDAA240MBB-2AE1ZABYY](#) [MTFDDAK1T9TDD-](#)
[1AT1ZABYY](#) [MTFDDAK3T8TDT-1AW1ZABYY](#) [MTFDDAK3T8TDS-1AW1ZABYY](#) [M25PX16-VMN6TP](#) [EDW4032BABG-70-F-D](#)
[MT47H32M16NF-25E IT:H TR](#) [MTFDDAV256TBN-1AR12ABYY](#) [MTFDDAK7T6TDS-1AW15ABYY](#) [MTFDDAK960TDT-](#)
[1AW1ZABYY](#) [MT40A256M16LY-062E AUT:F](#) [MTA9ASF1G72AZ-2G6E1](#) [MT48LC8M16A2P-6A:G](#) [LJDTT8GB-000-617](#)
[MT28EW01GABA1HJS-0SIT TR](#) [MT16KTF1G64AZ-1G4E1](#) [MTFC32GAKAEFF-AIT TR](#) [MT40A512M8SA-062E:F](#) [MTFDDAK3T8TDT-](#)
[1AW16ABYY](#) [MTFDDAK2T0TDL-1AW1ZABYY](#) [MT29F32G08CBADAWP:D](#) [MT29F4G08ABADAH4:D TR](#) [MTFDDAK1T9QDE-](#)
[2AV1ZABYY](#) [MTFC8GAKAJCN-1M WT](#) [MTFDDAC512MAM-1K1](#) [MT41K512M8DA-107 XIT:P TR](#) [MTFDHAL15T3TDP-](#)
[1AT1ZABYY](#) [MT40A2G16SKL-062E:B](#) [UF25B100](#) [MTFDDAK960TDT-1AW16ABYY](#) [MT40A512M8RH-083E:B](#) [MT48LC32M8A2P-](#)
[6A:G TR](#) [MTFDHAL7T6TCT-1AR1ZABYY](#) [MTA36ASF4G72PZ-2G9E2](#) [MTFDHBK256TDP-1AT12AIYY](#) [MT47H64M16NF-25E XIT:M](#)
[TR](#) [MT47H64M16NF-25E:M TR](#) [MTFDDAK064MBD-1AH12ITYY](#) [MT46H64M16LFBF-5 AIT:B TR](#) [MT29F1G08ABAFAP-ITE:F](#)
[MTFDHAL12T8TDR-1AT1ZABYY](#) [MTFDHBK1T0TDP-AAT12AIYYES](#) [MTSD1T0AKC7MS-1WTCS](#)