



# CAT809, CAT810

## 3-Pin Microprocessor Power Supply Supervisors

### FEATURES

- Precision monitoring of
  - +5.0 V ( $\pm 5\%$ ,  $\pm 10\%$ ,  $\pm 20\%$ ),
  - +3.3 V ( $\pm 5\%$ ,  $\pm 10\%$ ),
  - +3.0 V ( $\pm 10\%$ ) and
  - +2.5 V ( $\pm 5\%$ ) power supplies
- Offered in two output configurations:
  - CAT809: Active LOW reset
  - CAT810: Active HIGH reset
- Direct replacements for the MAX809 and MAX810 in applications operating over the industrial temperature range
- Reset valid down to  $V_{CC} = 1.0$  V
- 6  $\mu$ A power supply current
- Power supply transient immunity
- Available in SOT-23 and SC70 packages with Sn or NiPdAu GREEN lead finish
- Industrial temperature range:  $-40^{\circ}\text{C}$  to  $+85^{\circ}\text{C}$

### APPLICATIONS

- Computers
- Servers
- Laptops
- Cable modems
- Wireless communications
- Embedded control systems
- White goods
- Power meters
- Intelligent instruments
- PDAs and handheld equipment

### THRESHOLD SUFFIX SELECTOR

Nominal Threshold Voltage	Threshold Suffix Designation
4.63V	L
4.38V	M
4.00V	J
3.08V	T
2.93V	S
2.63V	R
2.32V	Z

### DESCRIPTION

The CAT809 and CAT810 are  $\mu$ P supervisory circuits that monitor power supplies in digital systems. The CAT809 and CAT810 are direct replacements for the MAX809 and MAX810 in applications operating over the industrial temperature range.

These devices generate a reset signal, which is asserted while the power supply voltage is below a preset threshold level and for at least 140 ms after the power supply level has risen above that level. The underlying floating gate technology, AE<sup>2</sup>(™) used by Catalyst Semiconductor, makes it possible to offer any custom reset threshold value. Seven industry standard threshold levels are offered to support +5.0 V, +3.3 V, +3.0 V and +2.5 V systems.

The CAT809 features a  $\overline{\text{RESET}}$  push-pull output (active LOW) and the CAT810 features a RESET push-pull output (active HIGH).

Fast transients on the power supply are ignored and the output is guaranteed to be in the correct state at  $V_{CC}$  levels as low as 1.0 V.

The CAT809/810 are fully specified over the industrial temperature range ( $-40^{\circ}\text{C}$  to  $85^{\circ}\text{C}$ ) and are available in compact 3-pin SOT23 and SC70 packages.

### PIN CONFIGURATION

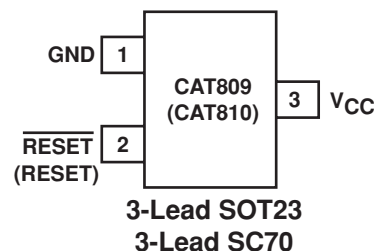

## ORDERING INFORMATION

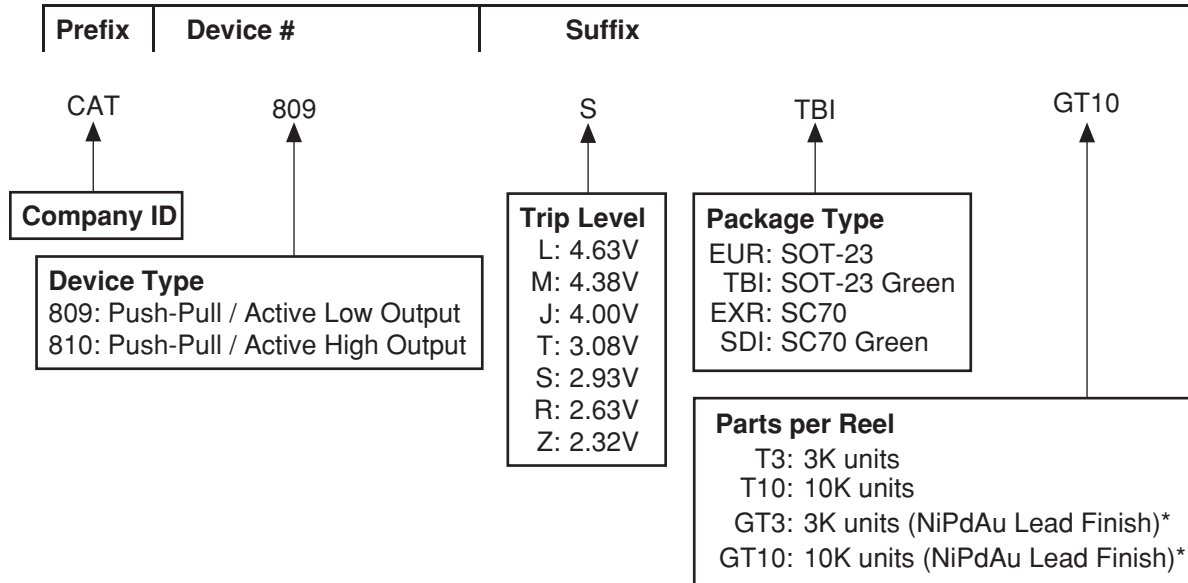

The device shown in the examples (CAT809STBI-GT10) has an Active Low, Push-Pull output; a trip level of 2.85V to 3.00V and is provided in the Green SOT-23 package with a NiPdAu lead finish on tape and reel with 10,000 units.

\* NiPdAu is a Lead Finish Option on the Green Packages only. Unless indicated with the "G", green packages are shipped with a Sn Matte Lead Finish.

## TOP MARKING

Parts and Threshold	SOT23 <sup>(1)</sup>	SOT-23 Green Sn Matte Lead Finish <sup>(1)</sup>	SOT-23 Green NiPdAu Lead Finish <sup>(1) (2)</sup>	SC70 <sup>(1)</sup>	SC70 Green Sn Matte Lead Finish <sup>(1)</sup>	SC70 Green NiPdAu Lead Finish <sup>(1) (2)</sup>
CAT809L	AAYM	DBYM	NRYM	FA_	GA_	NR_
CAT809M	ABYM	DCYM		FB_	GB_	
CAT809J	CWYM	CAYM		FG_	GG_	
CAT809T	ACYM	DFYM		FE_	GE_	
CAT809S	ADYM	DEYM		FD_	GD_	
CAT809R	AFYM	DDYM		FC_	GC_	
CAT809Z	CFYM	DGYM		FF_	GF_	
CAT810L	AGYM	CKYM	NSYM	FH_	GH_	NS_
CAT810M	AHYM	CLYM		FJ_	GJ_	
CAT810J	AIYM	CJYM		FP_	GP_	
CAT810T	AJYM	CPYM		FM_	GM_	
CAT810S	AKYM	CNYM		FL_	GL_	
CAT810R	ALYM	CMYM		FK_	GK_	
CAT810Z	CGYM	CRYM		FN_	GN_	

**Notes**

- 1) The "YM" in the SOT-23 package marking indicates the Year and Month of production and the "\_" in the SC70 package marking indicates the assembly location.
- 2) All NiPdAu devices will be marked to indicate product type and package. Threshold and full part numbers will be provided on box and reel labels as well as all Shipping documents.

**PIN DESCRIPTIONS**

Pin Number		Name	Description
CAT809	CAT810		
1	1	GND	Ground
2	—	$\overline{\text{RESET}}$	Active LOW reset. $\overline{\text{RESET}}$ is asserted if $V_{CC}$ falls below the reset threshold and remains low for at least 140ms after $V_{CC}$ rises above the reset threshold.
—	2	RESET	Active HIGH reset. RESET is asserted if $V_{CC}$ falls below the reset threshold and remains high for at least 140ms after $V_{CC}$ rises above the reset threshold.
3	3	$V_{CC}$	Power supply voltage that is monitored.

**ABSOLUTE MAXIMUM RATINGS\***

Any pin with respect to ground ..... -0.3 V to +6.0 V  
 Input Current,  $V_{CC}$  ..... 20 mA  
 Output Current, RESET,  $\overline{\text{RESET}}$  ..... 20 mA  
 Rate of Rise,  $V_{CC}$  ..... 100 V/ $\mu$ s  
 Continuous Power Dissipation  
     Derate 2.2mW/ $^{\circ}$ C above 70 $^{\circ}$ C (SC70) ..... 175 mW  
     Derate 4mW/ $^{\circ}$ C above 70 $^{\circ}$ C (SOT23) ..... 320 mW

Operating Temperature Range ..... -40 $^{\circ}$ C to +85 $^{\circ}$ C  
 Storage Temperature Range ..... -65 $^{\circ}$ C to +105 $^{\circ}$ C  
 Lead Soldering Temperature (10 sec) ..... 300 $^{\circ}$ C

**\*COMMENT**

Stresses above those listed under “Absolute Maximum Ratings” may cause permanent damage to the device. These are stress ratings only, and functional operation of the device at these or any other conditions outside of those listed in the operational sections of this specification is not implied. Exposure to any absolute maximum rating for extended periods may affect device performance and reliability.

**ELECTRICAL CHARACTERISTICS**

$V_{CC}$  = Full range,  $T_A$  = -40 $^{\circ}$ C to +85 $^{\circ}$ C unless otherwise noted. Typical values at  $T_A$  = +25 $^{\circ}$ C and  $V_{CC}$  = 5 V for the L/M/J versions,  $V_{CC}$  = 3.3 V for the T/S versions,  $V_{CC}$  = 3 V for the R version and  $V_{CC}$  = 2.5 V for the Z version.

Parameter	Symbol	Conditions	Min	Typ	Max	Units	
VCC Range		$T_A = 0^{\circ}\text{C to } +70^{\circ}\text{C}$	1.0		5.5	V	
		$T_A = -40^{\circ}\text{C to } +85^{\circ}\text{C}$	1.2		5.5		
Supply Current	$I_{CC}$	$T_A = -40^{\circ}\text{C to } +85^{\circ}\text{C}$	$V_{CC} < 5.5 \text{ V, J/L/M}$		8	20	$\mu\text{A}$
			$V_{CC} < 3.6 \text{ V, R/S/T/Z}$		6	15	
Reset Threshold Voltage	$V_{TH}$	L Threshold	$T_A = +25^{\circ}\text{C}$	4.56	4.63	4.70	V
			$T_A = -40^{\circ}\text{C to } +85^{\circ}\text{C}$	4.50		4.75	
		M Threshold	$T_A = +25^{\circ}\text{C}$	4.31	4.38	4.45	
			$T_A = -40^{\circ}\text{C to } +85^{\circ}\text{C}$	4.25		4.50	
		J Threshold	$T_A = +25^{\circ}\text{C}$	3.93	4.00	4.06	
			$T_A = -40^{\circ}\text{C to } +85^{\circ}\text{C}$	3.89		4.10	
		T Threshold	$T_A = +25^{\circ}\text{C}$	3.04	3.08	3.11	
			$T_A = -40^{\circ}\text{C to } +85^{\circ}\text{C}$	3.00		3.15	
		S Threshold	$T_A = +25^{\circ}\text{C}$	2.89	2.93	2.96	
			$T_A = -40^{\circ}\text{C to } +85^{\circ}\text{C}$	2.85		3.00	
		R Threshold	$T_A = +25^{\circ}\text{C}$	2.59	2.63	2.66	
			$T_A = -40^{\circ}\text{C to } +85^{\circ}\text{C}$	2.55		2.70	
		Z Threshold	$T_A = +25^{\circ}\text{C}$	2.28	2.32	2.35	
			$T_A = -40^{\circ}\text{C to } +85^{\circ}\text{C}$	2.25		2.38	

**ELECTRICAL CHARACTERISTICS** (continued)

$V_{CC}$  = Full range,  $T_A$  =  $-40^{\circ}\text{C}$  to  $+85^{\circ}\text{C}$  unless otherwise noted. Typical values at  $T_A$  =  $+25^{\circ}\text{C}$  and  $V_{CC}$  = 5 V for L/M/J versions,  $V_{CC}$  = 3.3 V for T/S versions,  $V_{CC}$  = 3 V for R version and  $V_{CC}$  = 2.5 V for Z version.

Parameter	Symbol	Conditions	Min	Typ <sup>(1)</sup>	Max	Units
Reset Threshold Tempco				30		ppm/ $^{\circ}\text{C}$
$V_{CC}$ to Reset Delay (Note 2)		$V_{CC} = V_{TH}$ to $(V_{TH} - 100\text{ mV})$		20		$\mu\text{s}$
Reset Active Timeout Period		$T_A = -40^{\circ}\text{C}$ to $+85^{\circ}\text{C}$	140	240	400	ms
RESET Output Voltage Low (Push-pull, active LOW, CAT809)	$V_{OL}$	$V_{CC} = V_{TH}$ min, $I_{SINK} = 1.2\text{ mA}$ CAT809R/S/T/Z			0.3	V
		$V_{CC} = V_{TH}$ min, $I_{SINK} = 3.2\text{ mA}$ CAT809J/L/M			0.4	
		$V_{CC} > 1.0\text{ V}$ , $I_{SINK} = 50\text{ }\mu\text{A}$			0.3	
RESET Output Voltage High (Push-pull, active LOW, CAT809)	$V_{OH}$	$V_{CC} = V_{TH}$ max, $I_{SOURCE} = 500\text{ }\mu\text{A}$ CAT809R/S/T/Z	$0.8 V_{CC}$			V
		$V_{CC} = V_{TH}$ max, $I_{SOURCE} = 800\text{ }\mu\text{A}$ CAT809J/L/M	$V_{CC} - 1.5$			
RESET Output Voltage Low (Push-pull, active HIGH, CAT810)	$V_{OL}$	$V_{CC} > V_{TH}$ max, $I_{SINK} = 1.2\text{ mA}$ CAT810R/S/T/Z			0.3	V
		$V_{CC} > V_{TH}$ max, $I_{SINK} = 3.2\text{ mA}$ CAT810J/L/M			0.4	
RESET Output Voltage High (Push-pull active HIGH, CAT810)	$V_{OH}$	$1.8\text{ V} < V_{CC} \leq V_{TH}$ min, $I_{SOURCE} = 150\text{ }\mu\text{A}$	$0.8 V_{CC}$			V

Note 1: Production testing done at  $T_A = +25^{\circ}\text{C}$ ; limits over temperature guaranteed by design only.

Note 2: RESET output for the CAT809; RESET output for the CAT810

**TYPICAL OPERATING CHARACTERISTICS**

$V_{CC}$  = Full range,  $T_A$  =  $-40^{\circ}\text{C}$  to  $+85^{\circ}\text{C}$  unless otherwise noted. Typical values at  $T_A = +25^{\circ}\text{C}$  and  $V_{CC} = 5\text{ V}$  for L/M/J versions,  $V_{CC} = 3.3\text{ V}$  for T/S versions,  $V_{CC} = 3\text{ V}$  for R version and  $V_{CC} = 2.5\text{ V}$  for Z version.

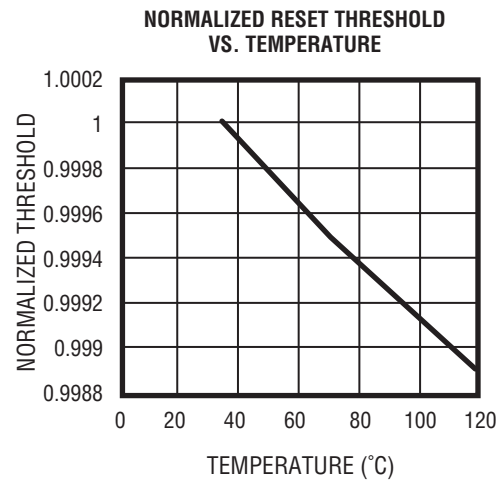
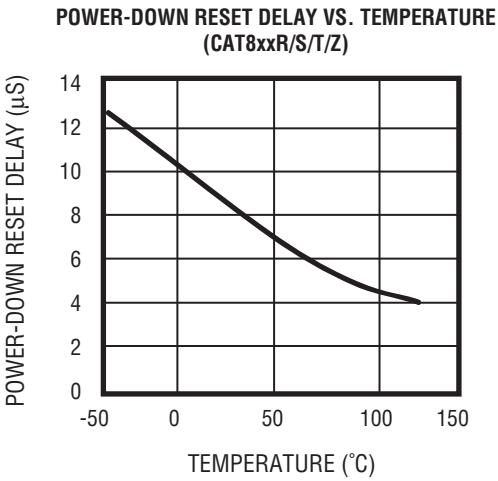
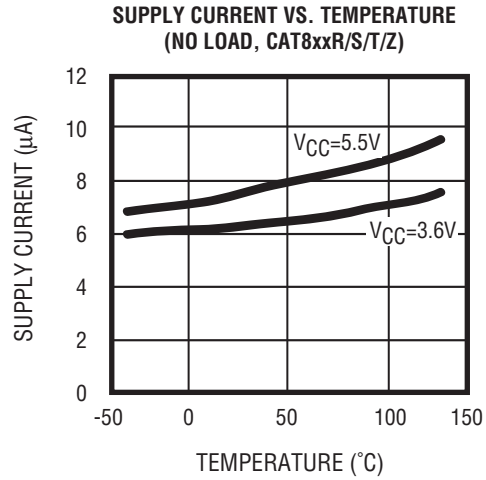
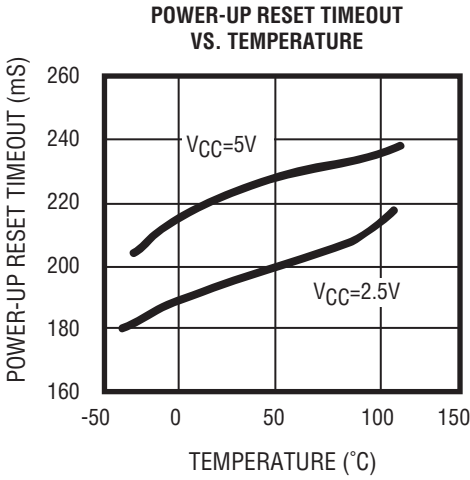

## DETAILED DESCRIPTIONS

### RESET TIMING

The reset signal is asserted LOW for the CAT809 and HIGH for the CAT810 when the power supply voltage falls below the threshold trip voltage and remains asserted for at least 140ms after the power supply voltage has risen above the threshold.

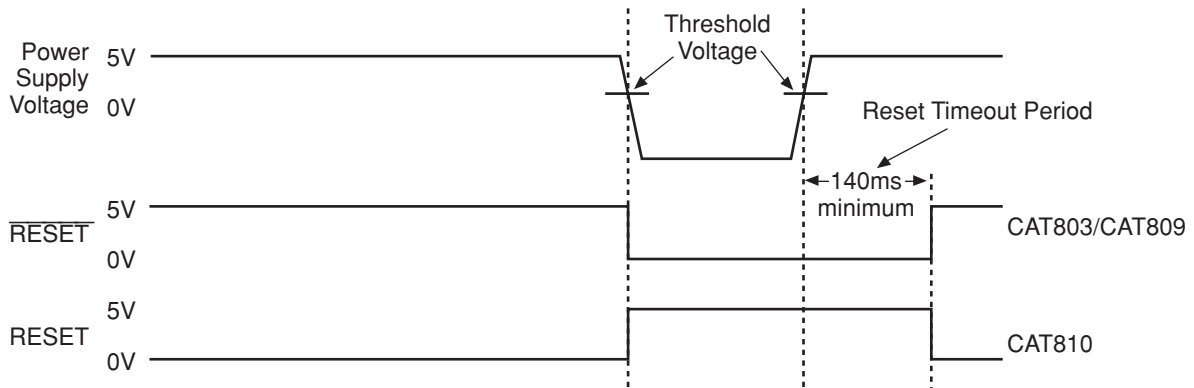

Figure 1. Reset Timing Diagram

### V<sub>CC</sub> TRANSIENT RESPONSE

The CAT809/810 protect  $\mu$ Ps against brownout failure. Short duration transients of 4 $\mu$ sec or less and 100 mV amplitude typically do not cause a false RESET.

Figure 2 shows the maximum pulse duration of negative-going V<sub>CC</sub> transients that do not cause a reset condition.

As the amplitude of the transient goes further below the threshold (increasing  $V_{TH} - V_{CC}$ ), the maximum pulse duration decreases. In this test, the V<sub>CC</sub> starts from an initial voltage of 0.5V above the threshold and drops below it by the amplitude of the overdrive voltage ( $V_{TH} - V_{CC}$ ).

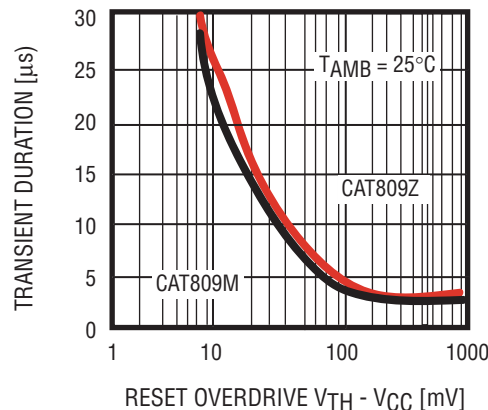

Figure 2. Maximum Transient Duration Without Causing a Reset Pulse vs. Reset Comparator Overdrive

**VALID RESET WITH V<sub>CC</sub> UNDER 1.0 V**

To ensure that the CAT809  $\overline{\text{RESET}}$  pin is in a known state when V<sub>CC</sub> is under 1.0 V, a 100 kΩ pull-down resistor between  $\overline{\text{RESET}}$  pin and GND is recommended; the value is not critical. For the CAT810, a pull-up resistor from RESET pin to V<sub>CC</sub> is needed.

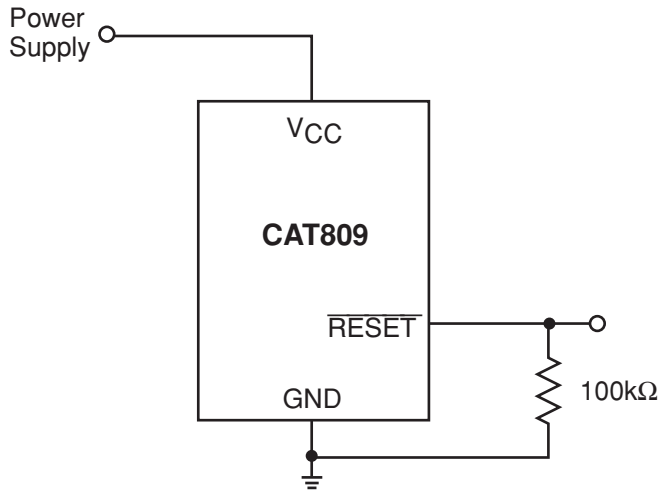

Figure 3.  $\overline{\text{RESET}}$  Valid with V<sub>CC</sub> Under 1.0 V

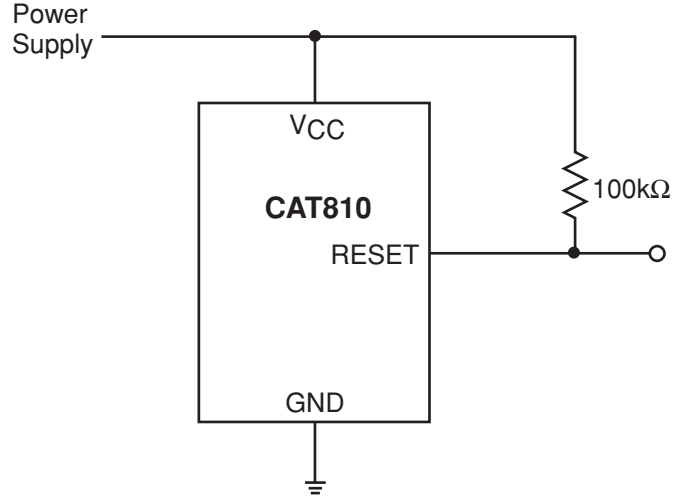

Figure 4. RESET Valid with V<sub>CC</sub> Under 1.1 V

**BI-DIRECTIONAL RESET PIN INTERFACING**

The CAT809/810 can interface with μP/μC bi-directional reset pins by connecting a 4.7 kΩ resistor in series with the CAT809/810 reset output and the μP/μC bi-directional reset pin.

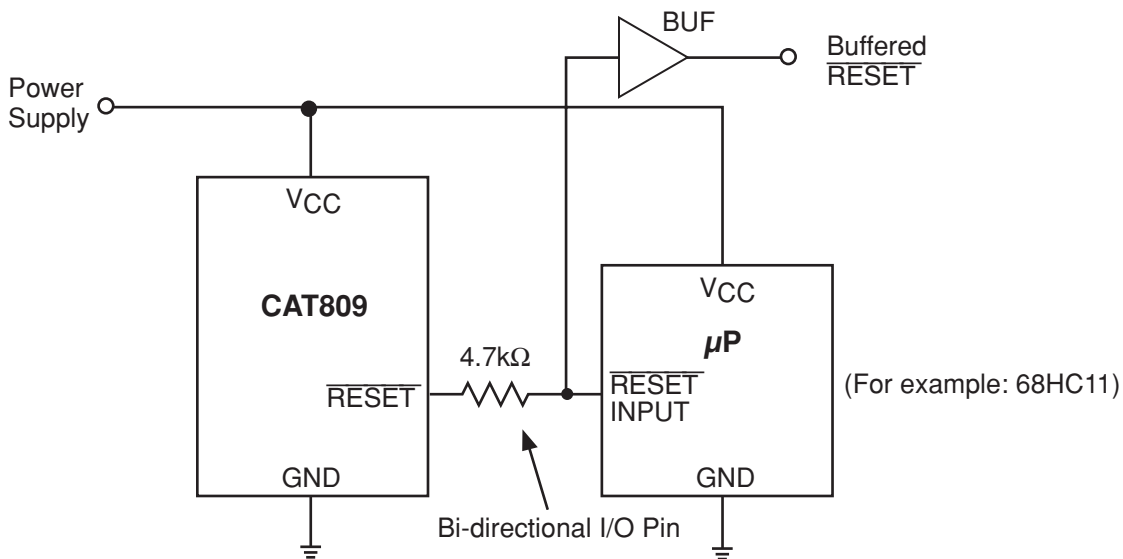

Figure 5. Bi-directional Reset Pin Interfacing



**OTHER SUPERVISORY PRODUCTS**

Function	CAT1161/3	CAT1162	CAT809	CAT810	CAT811	CAT812
With 16k Bit Serial EEPROM Memory	●	●				
Watchdog Timer	●					
Manual Reset Input	●	●			●	●
Active Low Reset			●		●	
Active High Reset				●		●
Dual Polarity Reset Outputs	●	●				
Package	8-pin DIP and SOIC	8-pin DIP and SOIC	3-pin SOT23 and SC70	3-pin SOT23 and SC70	4-pin SOT143	4-pin SOT143

**PACKAGE INFORMATION**

**Plastic SOT-23 (3-Pin)**

	Inches		Millimeters	
	Min	Max	Min	Max
<b>Plastic SOT-23 (3-Pin)</b>				
A	0.0350	0.0441	0.89	1.12
A1	0.0005	0.0039	0.013	0.10
B	0.0146	0.0197	0.37	0.50
c	0.0033	0.0071	0.085	0.18
D	0.1102	0.1197	2.80	3.04
E	0.0472	0.0551	1.20	1.40
e	0.0350	0.0406	0.89	1.03
e1	0.0701	0.0807	1.78	2.05
H	0.0827	0.1039	2.10	2.64
∞	0°	8°	0°	8°
L	0.0083	0.0161	0.275	0.41
L1	0.0160	0.0270	0.275	0.685

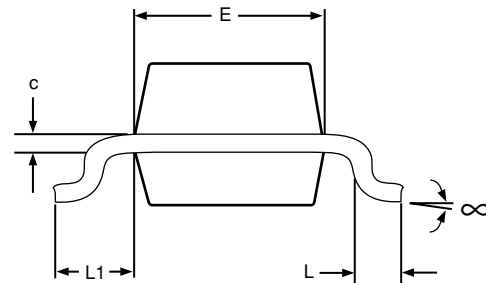
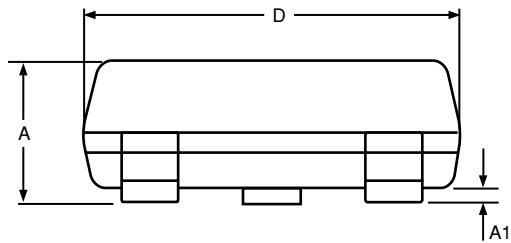
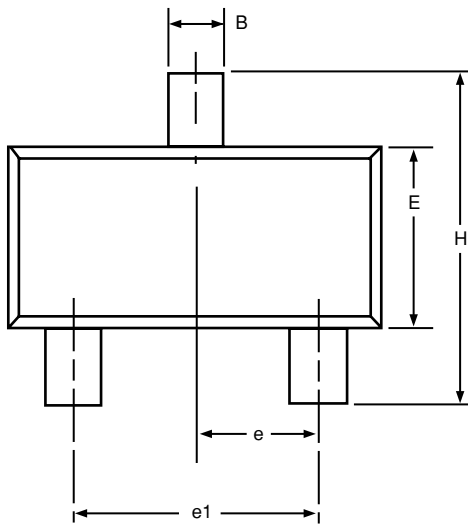

**NOTE:**

1. THIS PART IS COMPLIANT WITH JEDEC SPECIFICATION TO-236AB
2. DIE IS FACE UP FOR MOLD AND TRIM/FORM
3. DIMENSIONS ARE EXCLUSIVE OF MOLD FLASH AND METAL BURR

**PACKAGE INFORMATION**

**SC-70 Package (3-Lead)**

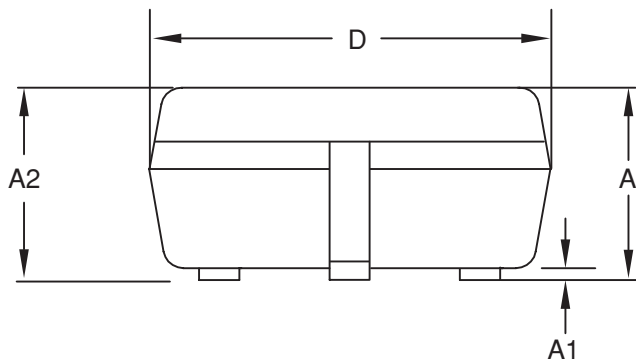
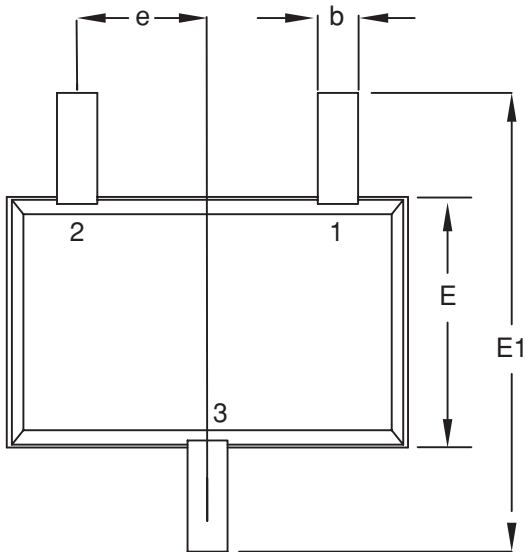

	Inches		Millimeters	
	Min	Max	Min	Max
<b>Plastic SC-70 (3-Pin)</b>				
A	0.0315	0.0433	0.80	1.10
A1	0.0000	0.0039	0.00	0.10
A2	0.0315	0.0394	0.80	1.00
b	0.0059	0.00118	0.15	0.30
c	0.0035	0.0071	0.09	0.18
D	0.0709	0.0866	1.80	2.20
E	0.0453	0.0531	1.15	1.35
E1	0.0709	0.0945	1.80	2.40
e	0.00255 BSC		0.65BSC	
L	0.0102	0.0181	0.26	0.46
L1	0.0108	0.0226	0.275	0.575

**NOTE:**

1. THIS PART IS COMPLIANT WITH EIAJ SPECIFICATION SC-70
2. DIE IS FACE UP FOR MOLD. DIE IS FACING DOWN FOR TRIM/FORM
3. DIMENSIONS ARE EXCLUSIVE OF MOLD FLASH AND METAL BURR

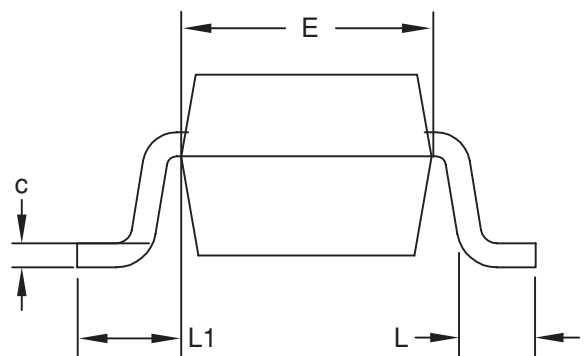

## REVISION HISTORY

Date	Rev.	Reason
10/29/2003	N	Updated VCC Transient Response text and Figure 2
10/30/2003	O	Updated Power Up Reset Timeout vs. Temperature curve
3/10/2004	P	Corrected temperature range Updated Description Updated Ordering Information Updated Absolute Maximum Ratings Updated Electrical Characteristics
03/23/2004	Q	Updated Description Updated Ordering Information Updated Absolute Maximum Ratings Updated Electrical Characteristics Updated Typical Operating Characteristics Updated Package Information
3/25/2004	R	Changed Preliminary designation to Final Updated Max Reset Active Timeout Period in Electrical Characteristics Updated package drawings
5/10/2004	S	Updated top marking table
12/28/2005	T	Updated Features Updated Ordering Information Updated Top Marking
02/17/2006	Q	Updated Typical Operating Characteristics

---

**Copyrights, Trademarks and Patents**

Trademarks and registered trademarks of Catalyst Semiconductor include each of the following:

DPP™ AE<sup>2</sup>™ MiniPot™

Catalyst Semiconductor has been issued U.S. and foreign patents and has patent applications pending that protect its products.

*CATALYST SEMICONDUCTOR MAKES NO WARRANTY, REPRESENTATION OR GUARANTEE, EXPRESS OR IMPLIED, REGARDING THE SUITABILITY OF ITS PRODUCTS FOR ANY PARTICULAR PURPOSE, NOR THAT THE USE OF ITS PRODUCTS WILL NOT INFRINGE ITS INTELLECTUAL PROPERTY RIGHTS OR THE RIGHTS OF THIRD PARTIES WITH RESPECT TO ANY PARTICULAR USE OR APPLICATION AND SPECIFICALLY DISCLAIMS ANY AND ALL LIABILITY ARISING OUT OF ANY SUCH USE OR APPLICATION, INCLUDING BUT NOT LIMITED TO, CONSEQUENTIAL OR INCIDENTAL DAMAGES.*

Catalyst Semiconductor products are not designed, intended, or authorized for use as components in systems intended for surgical implant into the body, or other applications intended to support or sustain life, or for any other application in which the failure of the Catalyst Semiconductor product could create a situation where personal injury or death may occur.

Catalyst Semiconductor reserves the right to make changes to or discontinue any product or service described herein without notice. Products with data sheets labeled "Advance Information" or "Preliminary" and other products described herein may not be in production or offered for sale.

Catalyst Semiconductor advises customers to obtain the current version of the relevant product information before placing orders. Circuit diagrams illustrate typical semiconductor applications and may not be complete.

---



Catalyst Semiconductor, Inc.  
Corporate Headquarters  
1250 Borregas Avenue  
Sunnyvale, CA 94089  
Phone: 408.542.1000  
Fax: 408.542.1200  
[www.catalyst-semiconductor.com](http://www.catalyst-semiconductor.com)

Publication #: 3004  
Revision: Q  
Issue date: 02/17/06

## X-ON Electronics

Largest Supplier of Electrical and Electronic Components

*Click to view similar products for [Supervisory Circuits](#) category:*

*Click to view products by [ON Semiconductor](#) manufacturer:*

Other Similar products are found below :

[NCP304LSQ38T1G](#) [NCP304LSQ40T1G](#) [NCP304LSQ42T1G](#) [NCP304LSQ43T1G](#) [NCP304LSQ46T1G](#) [NCP305LSQ11T1G](#)  
[NCP305LSQ16T1G](#) [NCP305LSQ17T1G](#) [NCP305LSQ18T1G](#) [NCP305LSQ24T1G](#) [NCP305LSQ25T1G](#) [NCP305LSQ29T1G](#)  
[NCP305LSQ31T1G](#) [NCP305LSQ32T1G](#) [NCP308MT250TBG](#) [NCP308SN300T1G](#) [NCP391FCALT2G](#) [NCV303LSN42T1G](#)  
[NCV308SN330T1G](#) [CAT1161LI-25-G](#) [CAT853STBI-T3](#) [CAT1026LI-30-G](#) [CAT1320LI-25-G](#) [CAT872-30ULGT3](#) [NCP304HSQ18T1G](#)  
[NCP304HSQ29T1G](#) [NCP304LSQ27T1G](#) [NCP304LSQ29T1G](#) [NCP304LSQ45T1G](#) [NCP305LSQ26T1G](#) [NCP305LSQ35T1G](#)  
[NCP305LSQ37T1G](#) [NCP308MT300TBG](#) [NCV300LSN36T1G](#) [NCV302LSN30T1G](#) [NCV303LSN16T1G](#) [NCV303LSN22T1G](#)  
[NCV303LSN27T1G](#) [NCV33161DMR2G](#) [TC54VN2402EMB713](#) [MCP1316T-44NE/OT](#) [MCP1316MT-45GE/OT](#) [MCP1316MT-23LI/OT](#)  
[MCP1316T-26LE/OT](#) [MAX8997EWW+](#) [MAX821RUS+T](#) [MAX6725AKASYD3-LF-T](#) [MAX6445UK31L+T](#) [MAX809SEUR](#)  
[MAX6701LKA+](#)