

Eaton®
Commercial Controls Division

S Series Snap Switches	4.2
Snap Switch Pushbutton Superstructure	4.8
Door Interlock Switches	4.9
Wiper/Dimmer Controls	4.10
Rotary Wiper Controls	4.12
Keylock Switches	4.14
ON-OFF Trigger Switch	4.16
AC Variable Speed Control Switch	4.17
Industrial Rocker	4.18
Locking Rocker	4.18
Sump Pump Switches	4.20
Accessories	4.22
Circuit Diagrams	4.28



4



Special Devices and Accessories



The Power of Reliability

4.1

4 SPECIAL DEVICES AND ACCESSORIES

S Series Snap Action Switches

DESCRIPTION

The S Series product group expands Eaton's snap action switch portfolio to cover all major amperages and operating forces. A wide range of sizes and options gives customers the ability to select the most appropriate switch for their specific application. Typical applications include computers, consumer electronics, small appliances, power tools, vending machines and packaging machinery.

Ultraminiature

The SC Series offers the smallest size with ratings of 0.1A and 3A. A choice of operating forces, terminations and lever combinations is available.

Subminiature

Slightly larger than the SC Series, the SE/SEV Series offers more options in operating force, termination, and lever style. This series also offers a 1PDT circuit and a 1PST circuit with either NO or NC terminals. The SEV version has VDE microgap approval.

Subminiature Waterproof

The SF Series is ideal for applications where the switch is subject to submergence of water or poor environmental conditions. It has one current rating and operating force but a variety of terminations and lever combinations. A 1PDT circuit and a 1PST circuit with either NO or NC terminals is available.

General

The SG Series is the standard size snap switch with amperages from 0.1A to 15A, and a variety of operating forces.

With VDE approval, the SGV Series has a contact distance of larger than 3mm.

Low Torque

The SJ Series is the low torque series designed to meet applications where a light actuating force is needed. A selection of operating forces and lever combinations is available.

SPECIFICATIONS

See specification table.

Approvals:   

● SEV and SGV series only.

SPECIFICATIONS TABLE

	SC ULTRAMINIATURE	SE SUBMINIATURE	SEV SUBMINIATURE VDE	SF SUBMINIATURE WATERPROOF	SG GENERAL	SGV GENERAL VDE	SJ LOW TORQUE
Operating Speed	1 to 500mm/sec.	0.1 to 1mm/sec.	0.1 to 1mm/sec.	0.1 to 1mm/sec.	0.1mm/sec. to 1m/sec.	0.1mm/sec. to 1m/sec.	1 to 360/sec.
Operating Frequency	200 ops./min. (mech) 30 ops./min. (elec)	300 ops./min.	300 ops./min.	300 ops./min.	Less than 300 ops./min.	400 ops./min.	240 ops./min. (mech) 20 ops./min. (elec)
Contact Resistance (Initial)	30m max.	30m max.	30m max.	30m max.	30m, 100m max.	30m max.	30m, 100m max.
Insulation Resistance	100M min. @ 250V dc	100M min.	100M min.	100M min.	100M min. @ 500V dc	100M min. @ 500V dc	100M min. @ 500V dc
Dielectric Strength	AC 1,000V RMS (50-60Hz)	AC 1,000V RMS (50-60Hz)	AC 1,000V RMS (50-60Hz)	AC 1,000V RMS (50-60Hz)	AC 1,000V RMS (50-60Hz)	AC 1,000V RMS (50-60Hz)	600V ac (50-60Hz)/ 1,500V ac (50-60Hz)
Shock Resistance: Electrical Mechanical	Approx. 30G Approx. 100G	More than 30G More than 100G	More than 30G More than 100G	More than 30G More than 100G	Approx. 30G Approx. 100G	More than 30G More than 100G	100G 100G
Ambient	-25°C to +85°C	-25°C to +85°C	-25°C to +85°C	-25°C to +85°C	-25°C to +85°C	-25°C to +125°C	-25°C to +80°C
Ambient Humidity	85% RH max.	85% RH max.	85% RH max.	85% RH max.	85% RH max.	85% RH max.	85% RH max.
Service Life: Electrical (at rated load, depending on type)	15,000-500,000 ops./min.	10,000-100,000 ops./min.	10,000 ops./min.	50,000 ops./min.	6,000-100,000 ops./min.	50,000-100,000 ops./min.	100,000 ops./min.
Service Life: Mechanical	10,000,000 ops./min.	10,000,000 ops./min.	10,000,000 ops./min.	2,000,000 ops./min.	10,000,000 ops./min.	10,000,000 ops./min.	10,000,000 ops./min.

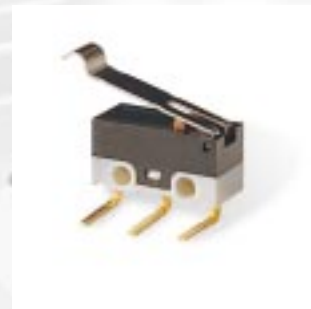

SC Series
Ultraminiature



SE Series
Subminiature



SEV Series
Subminiature VDE



HOW TO ORDER — SNAP ACTION SWITCH

To determine your **Complete Catalog Number**, you must start with the appropriate **Base Circuit Number** and add the appropriate **Code Letters** and/or **Numbers** as in the example below:

Start with this Base Circuit Number	...add each appropriate Code Number or Letter...					...to get to your Complete Catalog Number
Series Reference	Rating	Force	Termination	Lever	Circuit	Complete Catalog Number
SC	30	E	30	A	0	SC30E30A0

SNAP ACTION SWITCH SELECTION TABLE

Series	Ratings		Operating Force		Termination Type		Lever Type ❶		Circuit Type					
	Type	Code	Type	Code	Type	Code	Type (mm)	Code	Type	Code				
SC SERIES — ULTRAMINIATURE														
SC	0.1A/48V dc	10	See Page 4.4	C	PCB	30	Button	A	1 P.D.T.	0				
	3A/125V ac	30		E	PCB (Special)	40	Straight	C						
					Left-Angle (1.3mm)	50	Simulated Roller	E						
				Right-Angle	60									
SE SERIES — SUBMINIATURE														
SE	5A/125V ac	50	See Page 4.4	C	Solder	10	Button	A	1 P.D.T.	0				
				E	PCB	30	Straight (14.6)	B						
	10A/125V ac	70		G	Left-Angle (1.3mm)	50	Straight (16.6)	C	1 P.S.T.-NO	1				
					Right Angle	60	Straight (22.7)	D	1 P.S.T.-NC		2			
				Quick-Connect	70	S Roller (15.8)	E							
					Quick-Connect	70	Roller	G						
SEV SERIES — SUBMINIATURE VDE														
SEV	5A/125V ac	50	See Page 4.4	C	Solder	10	Button	A	1 P.D.T.	0				
				E			Straight (4.4)	B						
				G			PCB	30			Straight (6.4)	C		
							Straight (12.3)	D						
SF SERIES — SUBMINIATURE WATERPROOF														
SF	5A/125V ac	50	See Page 4.4	E	Solder	10	Button	A	1 P.D.T.	0				
							Straight (4.4)	B						
							PCB	30			Straight (6.4)	C	1 P.S.T.-NO	1
							Wire (Bottom)	90			Straight (12.3)	D	1 P.S.T.-NC	
							S Roller (5.9)	E						
							Roller	G						
SG SERIES — GENERAL														
SG	0.1A/125V ac	10	See Page 4.5	A	Solder	10	Button	A	1 P.D.T.	0				
	3A/125V ac	30		H			Screw	20			Straight (12.9)	B		
	6A/125V ac	60		J			PCB	30			Straight (27.2)	C	1 P.S.T.-NO	
				K			Right-Angle	60			Straight (51.1)	D		
	10A/125V ac	70		L			Quick Connect (.187")	70			S Roller (24.2)	E	1 P.S.T.-NC	2
	15A/125V ac	80		M			Quick Connect (.250")	72			Roller (12.2)	G		
								N			Quick Connect (.250")	72	Roller (25.6)	H
SGV SERIES — GENERAL VDE														
SGV	4A/125V ac	40	See Page 4.5	E	Quick Connect (.187")	70	Button	A	1 P.S.T.-NO	1				
							Straight (13.7)	B						
	10A/125V ac	70					M	Quick Connect (.250")			72	Straight (27.2)	C	
							Straight (51.0)	D						
							S Roller (24.2)	E						
							Roller (12.2)	G						
							Roller (25.6)	H						
SJ SERIES — LOW TORQUE														
SJ	5A/125V ac	50	See Page 4.5	L	Solder	10	Straight (50)	P	1 P.D.T.	0				
				S			Straight (65)	Q						
				H			Straight (80)	R						

❶ See page 4.6 for typical lever drawings.



4

4.3

4 SPECIAL DEVICES AND ACCESSORIES

S Series Snap Action Switches (continued)

OPERATING FORCE REFERENCE TABLE KEY

Abbreviation	Description	Abbreviation	Description	Abbreviation	Description	Abbreviation	Description
OF	Operating Force	PT	Pretravel	MD	Movement Differential	RF	Releasing Force
OP	Operating Position	OT	Overtravel	FP	Free Position		

OPERATING FORCE REFERENCE TABLE

Lever Type	OF Code	OF Maximum g/ounce	OP mm (inches)	PT Maximum mm (inches)	OT Minimum mm (inches)	MD Maximum mm (inches)	FP Maximum mm (inches)	RF Maximum g/ounce
SC SERIES — ULTRAMINIATURE								
A	C	90/3.25	7.00 ± .30 (.276)	1.30 (.051)	.20 (.008)	.20 (.008)	8.00 (.314)	15/5.25
	E	150/5.25						20/7
C	C	30/1.05	8.40 ± .80 (.330)	3.40 (.134)	.60 (.024)	.80 (.031)	11.00 (.433)	5/1.75
	E	50/1.75						8/2.8
E	C	25/88	10.50 ± .80 (.413)	3.30 (.129)	.60 (.024)	.80 (.031)	13.00 (.512)	4/0.14
	E	40/1.4						7/2.54
SE SERIES — SUBMINIATURE								
A	G	249/8.72	11.40 ± .30 (.449)	1.10 (.043)	.40 (.016)	.20 (.008)	12.20 (.480)	50/1.75
	E	148/5.18						35/1.23
	C	104/3.64						20/7
B	G	60/2.10	11.80 ± .80 (.465)	3.60 (.142)	.60 (.024)	.80 (.031)	14.60 (5.75)	15/5.25
	E	35/1.23						10/3.5
	C	25/88						6/2.1
C	G	55/1.93	11.80 ± .90 (.465)	4.00 (.157)	.60 (.024)	.80 (.031)	14.90 (.587)	13/4.55
	E	33/1.16						8/2.8
	C	25/88						6/2.1
D	G	45/1.58	11.80 ± 1.50 (.465)	6.10 (.240)	1.50 (.059)	1.50 (.059)	16.40 (.646)	13/4.55
	E	25/88						6/2.1
	C	20/7						5/1.75
E	G	56/1.96	13.70 ± 1.00 (.539)	4.60 (.181)	.80 (.031)	.80 (.031)	17.30 (.681)	13/4.55
	E	34/1.19						8/2.8
	C	25/88						5/1.75
G	G	60/2.1	17.50 ± .87 (.689)	3.80 (.150)	.80 (.031)	.80 (.031)	20.50 (.807)	15/5.25
	E	35/1.23						8/2.8
	C	25/88						6/2.1
SEV SERIES — SUBMINIATURE VDE								
A	G	249/8.72	11.40 ± .30 (.449)	1.10 (.043)	.40 (.016)	.20 (.008)	N/A	50/1.75
	E	146/5.11						35/1.23
	C	104/3.64						20/7
B	G	80/2.8	11.80 ± 1.10 (.465)	4.60 (.181)	.90 (.035)	.80 (.031)	N/A	14/4.9
	E	50/1.75						10/3.5
	C	35/1.23						6/2.1
C	G	70/2.45	11.80 ± 1.20 (.465)	5.10 (.200)	1.00 (.039)	.80 (.031)	N/A	13/4.55
	E	45/1.58						9/3.15
	C	30/1.05						5/1.75
D	G	55/1.93	11.80 ± 1.60 (.465)	6.90 (.270)	1.40 (.055)	1.10 (.043)	N/A	10/3.5
	E	35/1.23						7/2.45
	C	25/88						4/0.14
SF SERIES — SUBMINIATURE WATERPROOF								
A	E	203/7.11	8.40 ± .30 (.330)	1.20 (.047)	.60 (.024)	.10 (.004)	9.30 (.366)	50/1.75
B	E	57/2.0	8.80 ± 1.10 (.346)	4.30 (.169)	2.10 (.082)	.50 (.020)	12.00 (.472)	14/4.90
C	E	51/1.79	8.80 ± 1.20 (.346)	4.80 (.189)	2.40 (.094)	.60 (.035)	12.40 (.488)	13/4.55
D	E	39/1.37	8.80 ± 1.60 (.346)	6.30 (.248)	3.10 (.122)	.90 (.016)	13.50 (.531)	10/3.5
E	E	53/1.86	10.70 ± 1.20 (.421)	4.60 (.181)	2.30 (.091)	.40 (.016)	14.10 (.558)	13/4.55
G	E	57/2.0	13.90 ± 1.10 (.547)	4.30 (.169)	2.1 (.082)	.40 (.016)	17.10 (.669)	14/4.9

4.4 Refer to page 4.6 for definitions.

Refer to the Selection Table (page 4.3) and Lever Type Drawings (page 4.6).



OPERATING FORCE REFERENCE TABLE (continued)

Lever Type ❶	OF Maximum g/ounce							OP mm (inches)	PT Maximum mm (inches)	OT Minimum mm (inches)	MD Maximum mm (inches)
	A	B	C	D	E	F	G				
Code	H	J	K	L	M	N	P				
SG SERIES — GENERAL							SG SERIES — GENERAL				
A	18/.63	45/1.58	75/2.63	110/3.85	170/5.95	230/8.05	330/11.6	14.70 ± .50 (.579)	1.20 (.047)	1.27 (.050)	0.025 (.001)
B	18/.63	45/1.58	75/2.63	110/3.85	170/5.95	230/8.05	330/11.6	15.30 ± .50 (.602)	1.57 (.062)	1.27 (.050)	0.41 (.016)
	8/.28	27/.95	37/1.30	50/1.75	85/2.98	120/4.2	175/6.13	15.30 ± 1.10 (.602)	2.50 (.098)	2.00 (.079)	0.50 (.020)
C	8/.28	22/.77	37/1.3	50/1.75	86/3.01	125/4.38	180/6.3	15.30 ± 1.50 (.602)	3.18 (.125)	2.16 (.085)	0.76 (.030)
	5/.175	16/.56	22/.77	30/1.05	51/1.79	65/2.28	90/3.15	15.30 ± 2.30 (.602)	2.60 (.102)	3.30 (.130)	1.02 (.040)
D	—	13/.455	25/.88	30/1.05	49/1.72	70/2.45	120/4.2	15.30 ± 2.50 (.602)	7.60 (.299)	3.00 (.118)	1.20 (.047)
	—	8/.28	15/.525	20/.7	30/1.05	35/1.23	50/1.75	15.30 ± 4.30 (.602)	10.00 (.394)	5.00 (.197)	1.70 (.067)
E	10/.35	28/.98	43/1.51	55/1.93	91/3.19	120/4.2	172/6.02	18.70 ± 1.50 (.736)	3.18 (.125)	2.16 (.085)	0.76 (.030)
	7/.245	16/.56	24/.84	35/1.23	56/1.96	70/2.45	100/3.5	18.70 ± 2.10 (.736)	5.60 (.220)	3.30 (.130)	1.02 (.040)
G	20/.7	55/1.93	80/2.8	110/3.85	170/5.95	230/8.05	330/11.6	20.70 ± .80 (.815)	1.20 (.047)	1.02 (.040)	0.25 (.010)
	8/.28	35/1.23	55/1.93	70/2.45	100/3.5	120/4.2	175/6.13	20.70 ± 1.10 (.815)	2.50 (.098)	2.00 (.079)	0.40 (.016)
H	8/.28	30/1.05	50/1.75	55/1.93	100/3.5	125/4.38	180/6.3	20.70 ± 1.50 (.815)	3.18 (.125)	2.16 (.085)	0.76 (.030)
	5/.175	20/.7	30/1.05	40/1.4	51/1.79	65/2.28	90/3.15	20.70 ± 2.20 (.815)	5.08 (.200)	3.05 (.120)	1.02 (.040)

4

OPERATING FORCE REFERENCE TABLE (continued)

Lever Type ❶	OF Code	OF Maximum g/ounce	OP mm (inches)	PT Maximum mm (inches)	OT Minimum mm (inches)	MD Maximum mm (inches)
SGV SERIES — GENERAL VDE						
A	E	510/17.9	14.40 ± .50 (.555)	1.90 (.074)	.70 (.028)	-1.20 (-.047)
	M	—	—	—	—	—
B	E	447/15.6	15.00 ± .60 (.590)	2.20 (.087)	.80 (.031)	1.40 (.055)
	M	314/11.0	15.00 ± .90 (.590)	3.10 (.122)	1.10 (.043)	2.00 (.079)
C	E	225/7.88	15.00 ± 1.20 (.590)	4.30 (.169)	1.60 (.063)	2.70 (.106)
	M	185/6.48	15.00 ± 1.40 (.590)	5.20 (.204)	1.90 (.075)	3.30 (.130)
D	E	120/4.2	15.00 ± 2.20 (.590)	8.10 (.319)	3.00 (.118)	5.10 (.201)
	M	108/3.78	15.00 ± 2.40 (.590)	9.00 (.354)	3.30 (.130)	5.70 (.224)
E	E	253/8.86	18.40 ± 1.00 (.724)	3.80 (.150)	1.40 (.055)	2.40 (.094)
	M	204/7.14	18.40 ± 1.30 (.724)	4.80 (.189)	1.70 (.067)	3.00 (.118)
G	E	502/17.6	20.40 ± .50 (.803)	1.90 (.075)	.70 (.028)	1.20 (.047)
	M	340/11.9	20.40 ± .80 (.803)	2.90 (.114)	1.00 (.039)	1.80 (.071)
H	E	239/8.37	20.40 ± 1.10 (.803)	4.10 ± (.161)	1.50 (.059)	2.60 (.102)
	M	195/6.83	20.40 ± 1.30 (.803)	5.00 (.197)	1.80 (.071)	3.20 (.125)

OPERATING FORCE REFERENCE TABLE (continued)

Lever Type ❶	OF Code	OT Maximum g-cm (oz.-in.)	Releasing Torque Min. g-cm (oz.-in.)	PT Maximum	OT Minimum	MD Minimum	Return Travel Minimum	Total Travel	FP
SJ SERIES — LOW TORQUE									
P, Q, R	L	5.1 (0.0708)	0.6 (0.0083)	21°	17°	2°	5°	38°	15 ± 3°
P, Q, R	S	7.6 (0.1054)	0.9 (0.0125)	21°	17°	2°	5°	38°	15 ± 3°
P, Q, R	H	10.2 (0.1415)	1.3 (0.0180)	21°	17°	2°	5°	38°	15 ± 3°

❶ Reference the Selection Table (page 4.3) and Lever Type Drawings (page 4.6).



4.5

4 SPECIAL DEVICES AND ACCESSORIES

S Series Snap Action Switches (continued)

LEVER TYPE REFERENCE TABLE

These drawings show the SG and SJ Series. Construction for other Series may vary slightly. Refer to Selection Table (page 4.3) for Lever Length.

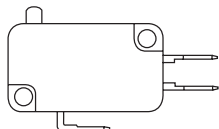
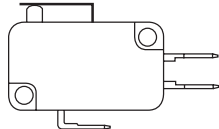
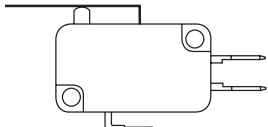
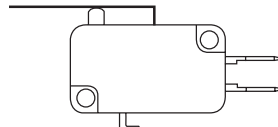
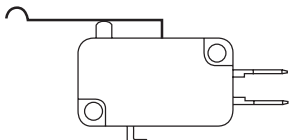
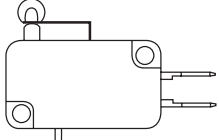
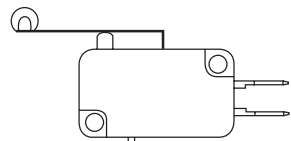
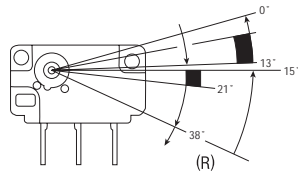
LEVER TYPES	
 Button Code A	 Straight Code B
 Straight (Medium) Code C	 Straight (Long) Code D
 Simulated Roller Code E	 Roller (Short) Code G
 Roller (Long) Code H	 Series SJ Code P, Q, R

MECHANICAL TERMS

MECHANICAL TERMS			
Free Position	The unoperated, fully extended position of the actuator.	Movement Differential	Distance or angle the actuator travels in returning from Operating Position to Reset Position.
Pretravel	Distance or angle the actuator travels from free position to the Operating Position.	Release Force	The amount of external force or torque the switch will overcome when returning from Overtravel Position to Free Position.
Operating Position	The position of the actuator when the snap action of all switch contacts occurs during actuation stroke.	Total Travel	The sum of pretravel and overtravel.
Operating Force	Force or torque applied to the actuator to reach the Operating Position.	Snap Action	A rapid motion of the contacts from one position to another. Snap Action is independent of rate of travel of actuator.
Overtravel	Movement of actuator from Operating Position to final position at end of actuating stroke.	Contact Pressure	At any point, the amount of force holding stationary and movable contacts together.
Overtravel Force	Force or torque applied to actuator to move from Operating Position to full Overtravel Position.	Contact Gap	The effective open distance between the movable and stationary contacts.
Reset Position	Position of actuator when all switch contacts return to positions prior to actuation.	Multiple Break	An arrangement of contacts such that the circuit is broken simultaneously in several places.

DEFINITION OF OPERATING CHARACTERISTICS

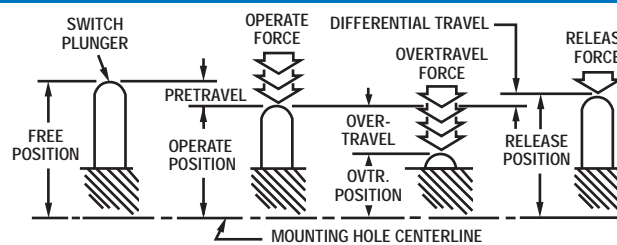



DIMENSIONS APPROXIMATE IN MM (INCHES)

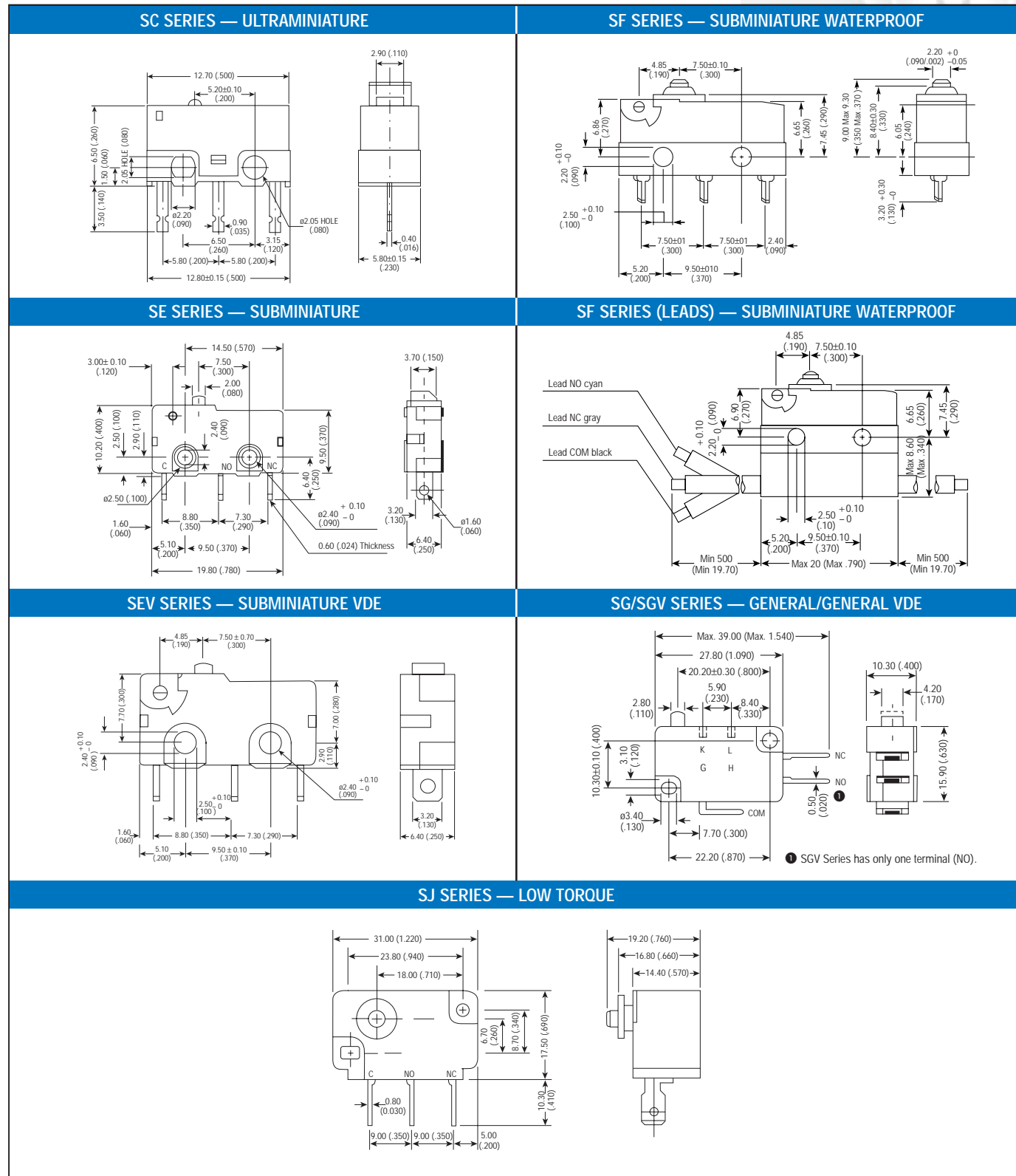

4 SPECIAL DEVICES AND ACCESSORIES

Snap Switch Pushbutton Superstructure

DESCRIPTION

These Non-Illuminated Pushbutton Actuators complement our S Series Snap Switch Line featured on pages 4.2-4.7. The actuators are available in three different non-illuminated versions. The line is complete with attractive colored pushbutton caps for color coding applications. Two of the series of superstructures are available with

attractive mounting collars. They come in a variety of colors which act as a protective collar around the operating button to prevent accidental operation of the switch.

These superstructures are designed for installation in a 12.07mm (.475") diameter-mounting hole. All series are supplied with a flat surface on the bushing to prevent rotation. In the series requiring the mounting collar, the collar itself is

the facenut tightening the switch/superstructure assembly down to the panel.

Options:

- NO and NC circuits.
- Pad printed buttons.
- Other colors available.
- PC terminals available.
- Round 17.78mm (.700") button, different heights.

SNAP SWITCH SELECTION TABLE

Number of Poles	Electrical Rating	Operation Characteristics	Terminals	BASE CAT. NUMBER ❶	Superstructure Style ❶		Pushbutton Color ❶		Pushbutton Shroud ❶																		
					Type	Code	Color	Code	Color	Code																	
HIGH ELECTRICAL																											
1 (One Snap Switch) Momentary	UL Recognized and CSA Certified: 15A, 125-250V ac 1/2 Hp, 125-250V ac 1/2A, 125V dc 1/4A, 250V dc 28V dc: Sea Level: 10A, Res. or Ind. 6A, Motor Load 50,000 Ft. 10A, Res./6A Ind.	Op. Force — 6 to 14 oz. Release Force — 4 oz. min. Pretravel — 1.19mm (.047") max. Differential Travel — .41mm (.016") max. Overtravel — 1.01mm (.040") min. Mechanical Life — 150,000 op. min. with min. median of 1 million. Op. Position — 14.7mm (.578 ± .015") Free Position — 16.2mm (.640") max.	Screw Solder Lug Quick Connect (.188") Quick Connect (.250") Short Solder Lug	SA37BCE1	Round 17.78mm (.700") Dia.	2	White	-10	Round Button Shroud	White	A1																
				SA37BCE2								Rectangular 19.43 x 15.37mm (.765 x .605")	5	Black	-9	Black	Grey	A6									
				SA37BCE3															Grey	-11	Rectangular Shroud	Grey	A5				
				SA37BCE4																				Yellow	-5	White	B1
				SA37BCE5																							
1 (One Snap Switch) Momentary	UL Recognized and CSA Certified: 10A, 125-250V ac 1/3 Hp, 125-250V ac 1/2A, 125V dc 1/4A, 250V dc 28V dc: Sea Level: 10A, Res. or 6A Ind. 6A, Motor Load 3.6A, Lamp Load 50,000 ft.: 10A, Res./6A Ind.	Op. Force — 8 oz. max. Release Force — 2 oz. min. Pretravel — 1.19mm (.047") max. Differential Travel — .15 to .41mm (.006 to .016") Overtravel — 1.01mm (.040") min. Mechanical Life — 1 million op. min. with min. median of 10 million. Op. Position — 14.7mm (.578 ± .015") Free Position — 16.2mm (.640") max.	Screw Solder Lug Quick Connect (.188") Quick Connect (.250") Short Solder Lug	SA37BCB1	13.97mm (.550") Dia. ❷	4	Orange	-12	Grey	B5																	
SA37BCB2	Rectangular 19.43 x 15.37mm (.765 x .605")	5	Blue	-4							Blue	Grey	A5														
SA37BCB3														Grey	-11	Rectangular Shroud	Grey	A5									
SA37BCB4																			Yellow	-5	White	B1					
SA37BCB5																							Green	-6	Black	B6	

❶ Add code letters and numbers for Superstructure Style, Pushbutton Color and Pushbutton Shroud Color (if applicable). Example: SA37BCE12-2A6.
 ❷ Not available with decorative shroud.

DIMENSIONS APPROXIMATE IN MM (INCHES)

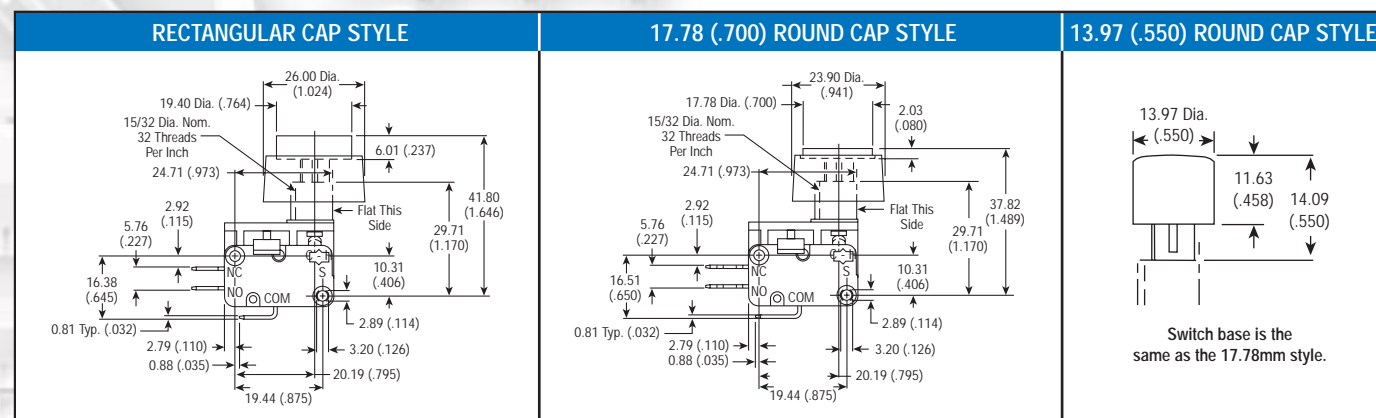

Door Interlock Switches

DESCRIPTION

Door interlock switches are attached to the door of equipment where it is necessary to turn power on or off when the door is closed or opened. This type of control is used in applications where maintenance and testing must be performed inside a cabinet.

Interlock switches are supplied with one 1PDT snap action switch or two 1PDT miniature snap action switches.

The snap action switches are mounted in a frame and a single actuator, which is spring loaded, operates the switch. When mounted in a door, the closing of the door forces the actuator against the spring thereby closing the switch. When the door is open, the actuator springs out thereby opening the power circuit.

The interlock switch has a service position, which allows service personnel to turn power on even when the cabinet door is open. When the door is closed, the switch automatically resets to the normal closed position.

SPECIFICATIONS:

Ratings:

See selection table.

Operating Features:

Free position — 9.53mm (.375") max.

Operate position — 5.12mm (.203") max.

Depressed position — 3.17mm (.125") max.

Materials and Finishes:

Switch — Contact Eaton Customer Service.
1-800-962-0820

Bracket — Stainless steel.

Actuator — 1 Pole — Molded noryl; 2 Pole — stainless steel.

Spring — Stainless steel.

Insulator — Glass cloth.

Mounting:

Tapped holes are provided for mounting in either of two positions — 2 screw side or front panel mounting. Mounting hardware is not provided.

Options:

- Special circuits.
- Solder lug, spade, and PC terminations.
- Special actuators.

Approvals:

UL Recognized.
CSA Certified.



DOOR INTERLOCK SELECTION TABLE (BOLD FACE TYPE INDICATES ITEMS NORMALLY IN DISTRIBUTOR STOCK)

Nominal Ratings ①				Number of Poles	Features	Screw Terminal Catalog Number
Amperes			Horsepower			
125-250V ac	125V dc	250V dc	125-250V ac			
15	0.5	0.25	1/2	One Pole	#6-32 Tapped hole in actuator (.375") deep	SS12ET10-20Y3 SS12ET10-20Y2
15	0.5	0.25	1/2	Two Pole	#6-32 Tapped hole in actuator (.375") deep	SS12ET10-21Y3 SS12ET10-21Y2

① Sea Level: 10A, Resistive or Inductive; 6A, Motor Load. 50,000 feet: 10A, Resistive; 6A, Inductive.

DIMENSIONS APPROXIMATE IN MM (INCHES)

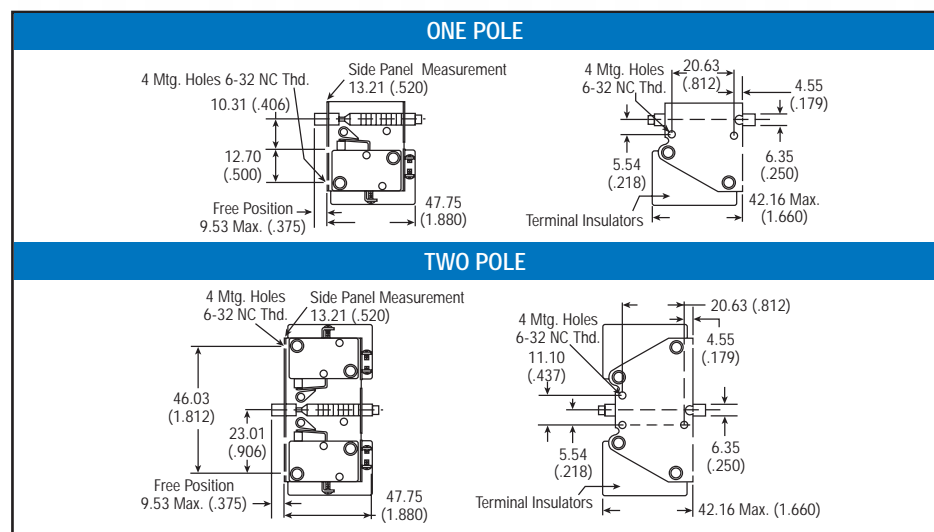

EATON



SA37BCB42-2A6
Pushbutton Superstructure



SA37BCE45-10B6
Pushbutton Superstructure



SS12ET10-20Y2
Door Interlock



SS12ET10-21Y2
Door Interlock

4 DIMMER AND WIPER CONTROLS

Paddle and Slide Controls

DESCRIPTION

Eaton's unique family of dimmer and wiper controls are field proven to be the market's most dependable controls. Although originally designed for the heavy truck market, applications in various other types of vehicles exist. Paddle and slide versions are available and both have the look, feel and durability associated with our controls. Bezels and actuators are molded in a soft matte finish. Illuminated and non-illuminated versions are available. Board mounted LED's located behind a laser etched

panel provide illumination. Customized light panel lettering and custom pad printed bezels are also available. Both dimmer and wiper controls are designed to fit in the NGR gang mount system to compliment the NGR family of switches.

SPECIFICATIONS

Ratings (Dimmer Only):

4, 6, 8, 10A @ 14V dc.
2, 3, 4, 5A @ 28V dc.

Mechanical Life:

100,000 operations, maximum.

Operating Temperature Range:

-40°C to +85°C
(-40°F to 185°F).

Base Material:

High grade thermoplastic molding material.

Mounting Means:

Snap-in mounting with plastic bezel.

Mounting Hole:

Rectangular panel cutout.
44 x 22mm
(1.734 x .867").

Panel Thickness:

.76 x 4.80mm
(.030 to .190").

Approximate Weight:

1.5 oz.

HOW TO ORDER — PADDLE AND SLIDE CONTROLS

To determine your **Complete Catalog Number**, you must start with the appropriate **Control Type** and add the appropriate **Code Letters** and/or **Numbers** as in the example below:

Add each appropriate Number or Letter...								...to get to your Complete Catalog Number
Control Type	Actuator Type	Application Voltage	Amperage Rating	Bezel Print Style	Connector Type	Circuit Board	LED Color	Complete Catalog Number
D	P	12	4	A	A	L	G	DP124AALG

PADDLE AND SLIDE CONTROLS SELECTION TABLE

CODE LETTERS AND NUMBERS																	
Control Type	Code	Actuator Type	Code	Application Voltage	Code	Amperage Rating ¹	Code	Bezel Print Style	Code	Connector Type Packard No.	Code	Circuit Board ²	Code	LED Color	Code		
Dimmer	D	Paddle	P	12 Volts	12	4	4	Style A	A	12020398	A	18 Sec. Max Nominal Dwell	L	Green	G		
						6	6	Style B	B	12015345	B					10 Sec. Max Nominal Dwell	S
Wiper	W	Slide	S	24 Volts	24	8	8	Style C	C	174930-1	C	Dimmer	D	Red	R		
						10	10	Style D	D	12034295	D					Non-Illuminated	X
						Wiper	W	Leads Only	E								

BEZEL PRINT STYLE ³

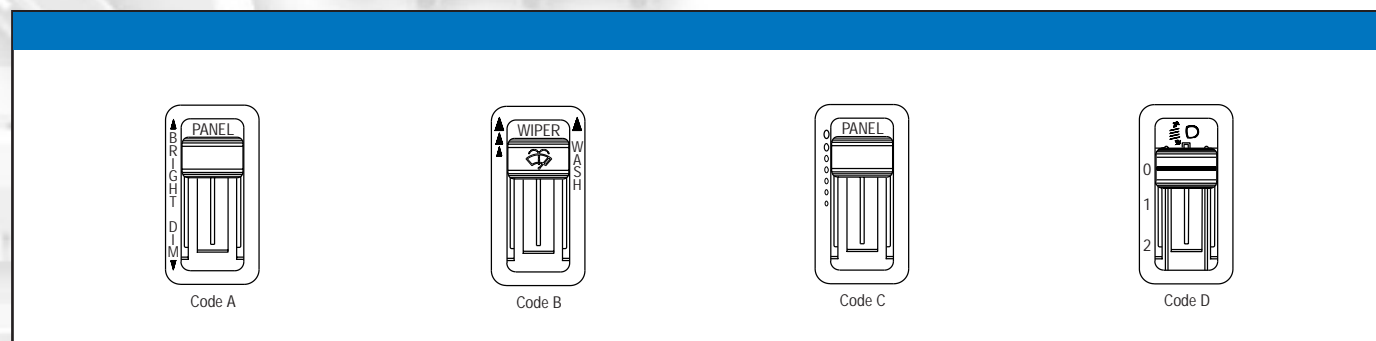

¹ Amperage ratings for dimmers only.
² Maximum dwell time describes the average time constant for delayed wiper activation.
³ Custom Pad print available for bezel or button.



DIMENSIONS APPROXIMATE IN MM (INCHES)

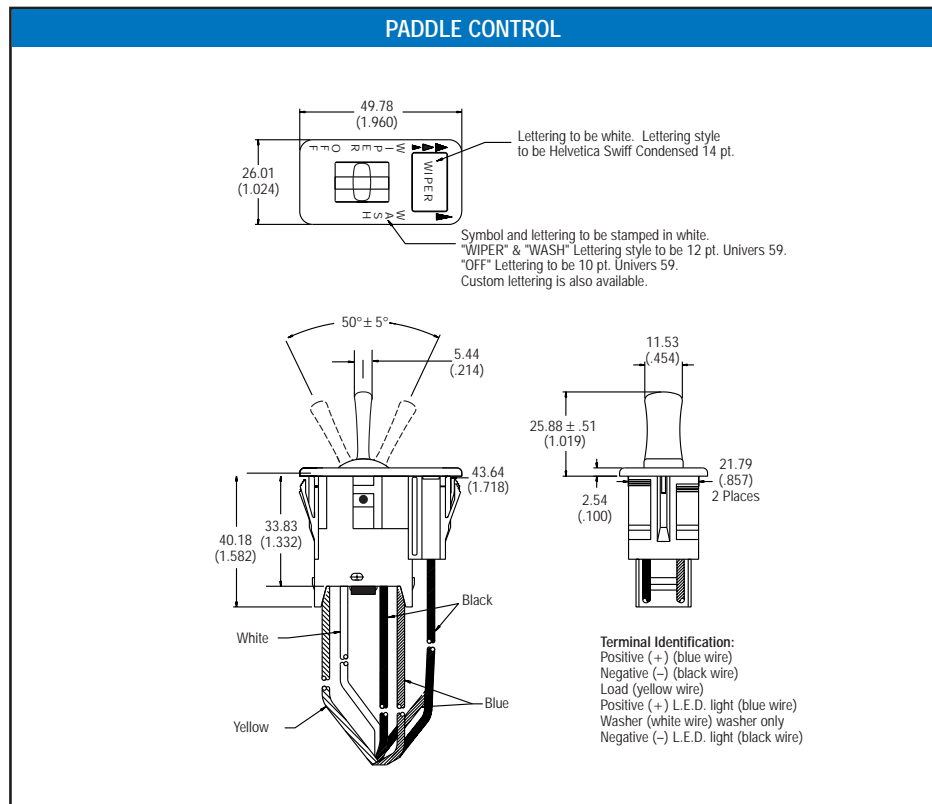

DS126AEDY
Dimmer Slide Control



DP124AEDY
Dimmer Paddle Control

4

DIMENSIONS APPROXIMATE IN MM (INCHES)

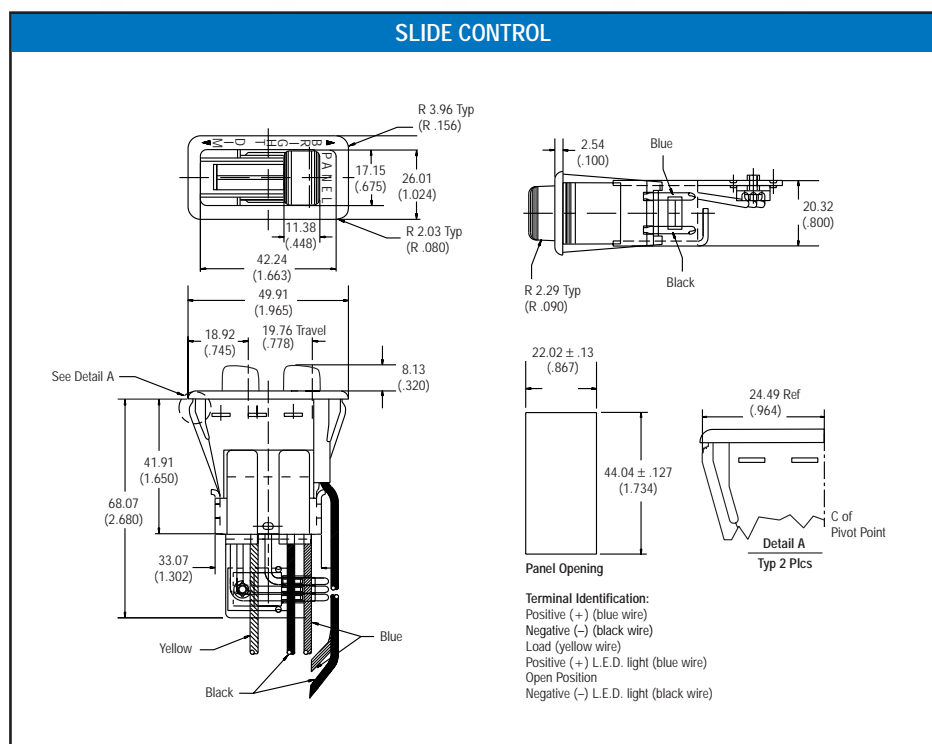

WS12WBESY
Wiper Slide Control



WP12WBELY
Wiper Paddle Control

4.11

4 DIMMER AND WIPER CONTROLS

RW 200 Series Rotary Wiper

DESCRIPTION

The Rotary Wiper has been designed to be a highly durable rotary wiper control for the transportation industry. The RW200 series wiper has four wiper control positions via a rotating knob: Off, Intermittent, Continuous Low Speed and Continuous High Speed. The device has a washer function that operates the washer pump and wiper while the knob is depressed.

Meets SAE standards J1455, J1944 and J1988.

SPECIFICATIONS

Operating Voltage Range:
9V dc to 16V dc.

Continuous Load Rating:

17A from -40°C to 23°C
(-40°F to 73°F).

Derated to 5A @ 85°C (185°F).

Wiper Electromechanical Life:

50,000 Cycles.

Electrical Cycle Life:

250,000 Cycles in the Intermittent Position.

300,000 Cycles combined in the Low and High Positions.

300,000 Cycles combined in the Low and High Positions.

Operating Temperature:

-40°C to 85°C

(-40°F to 185°F).

Humidity Rating:

Device will operate properly

at 98% humidity between

-40°C to 38°C

(-40°F to 100°F).

Mechanical Shock:

The switch will withstand a three foot drop on concrete.

Vibration:

The device will operate properly while being exposed to 133 hours of 1 G RMS vibration along all 3 axis, sweeping from 5 Hz to 1500 Hz at 1 octave per minute.

Load Dump Protection:

The switch will withstand a 120 Volt Load Dump per SAE J1455.

Reverse Voltage Protection:

The device shall not be damaged when exposed to 12V dc for 5 minutes.

Options:

- Variable bushing length.
- Variable spindle length.
- Choice of connectors.
- Pad printing on knob.

ROTARY WIPER SELECTION TABLE

Series	Voltage	Packard Connectors	Bushing Length	Catalog Number
RW	12V dc	12064752	.261"	RW20012AA
		12064752	.424"	RW20012AB
		12977042	.261"	RW20012BA
		12977042	.424"	RW20012BB
		6288538	.261"	RW20012CA
		6288538	.424"	RW20012CB
		6294544 & 2977048	.261"	RW20012DA
		6294544 & 2977048	.424"	RW20012DB

CONNECTOR DRAWINGS

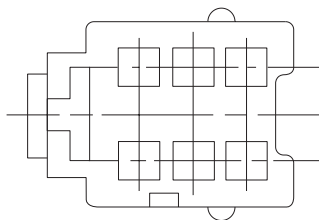

12064752

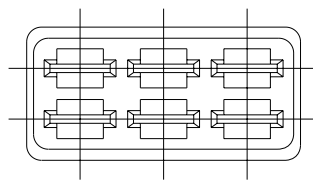

12977042

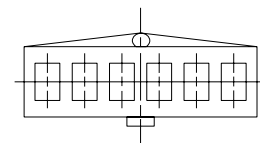

6288538

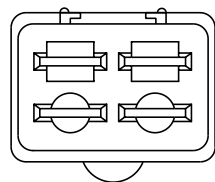

6294544

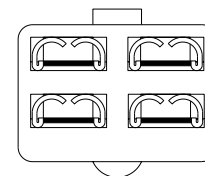

2977048



DIMENSIONS APPROXIMATE IN MM (INCHES)

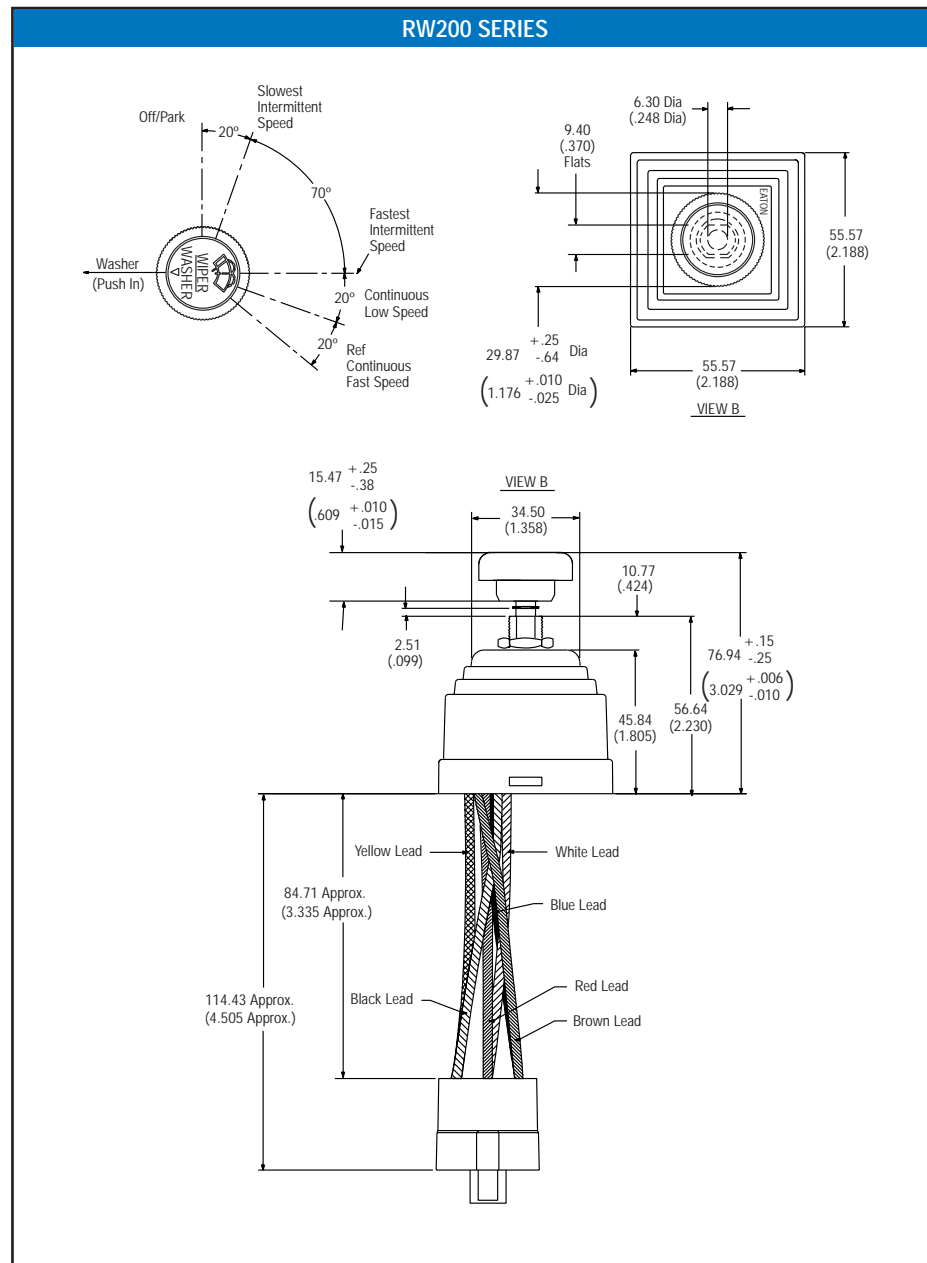

Rotary Wiper

4

CIRCUIT CONTINUITY

SWITCH POSITION	CIRCUIT CONTINUITY
Off	Open
Intermittent	Yellow – Red and Brown
Low Speed	Yellow
High Speed	White
Washer	Brown
	Red – Positive
	Black – Negative

WIRE TERMINATIONS

WIRE COLOR	SWITCH CONNECTIONS
Yellow	Motor Low Speed Terminal
White	Motor High Speed Terminal
Blue	Motor Park Terminal
Black	Ground
Brown	Washer Pump
Red	+ 12V dc (Positive)

4 SPECIAL DEVICES AND ACCESSORIES

General Purpose Heavy Duty Keylock Switches — AC/DC Rated

DESCRIPTION

General Purpose

These keylock switches provide reliable performance in a space saving design. They all utilize Quick-make/Quick-break switching mechanisms, with wiping action blades for self-cleaning contacts.

Heavy Duty

These switches have a Slow-make/Slow-break switching mechanism with large butt type contacts. Their high current switching capability allows them to be used for locking switching circuits in power applications.

SPECIFICATIONS

Ratings:

See selection table.

Circuits:

General Purpose

1PST, 1PDT, 2PST, 2PDT.
Maintained action.

Heavy Duty

2PST, 2 Circuit.
Maintained.

Contact Mechanism:

General Purpose

Quick-make/Quick-break wiping action.

Heavy Duty

Slow-make/Slow-break butt contact.

Contact Material:

General Purpose

Movable — Bronze silver plated.
Stationary — Brass silver plated.

Heavy Duty

Movable — Silver cadmium oxide.
Stationary — Silver cadmium oxide.

Termination Types:

General Purpose

Solder Lugs — Brass silver plated.

Heavy Duty

7842 Series:

Screw Terminals — Brass designed to accept #7-32 x 3/16 binding head (Cat. No. 11-6085-2) screws. Furnished unassembled.

7846 Series:

Quick-Connect Terminals — Brass.

GENERAL PURPOSE KEYLOCK AC/DC SWITCHES SELECTION TABLE

Rating	Poles and Throw	Circuit with Key in... (Keyway Down)			Key Removal Position	Solder Lug Terminals Catalog Number
		LEFT Position	CENTER Position (Keyway)	RIGHT Position		
6A, 125V ac/dc 3A, 250V ac/dc	1 P.S.T	— —	OFF OFF	ON ON	CENTER CENTER AND RIGHT	8928K492 8928K493
6A, 125V ac/dc 1A, 250V ac/dc	1 P.D.T.	—	ON	ON	CENTER AND RIGHT	8928K494
6A, 125V ac/dc 1 1/2A, 250V dc	1 P.D.T.	—	ON	ON	CENTER	8283K150
6A, 125V ac/dc 3A, 250V dc	2 P.S.T.	— ON	OFF ON OFF	ON OFF —	CENTER CENTER LEFT	8370K150 8370K151 8370K152
6A, 125V ac/dc 3A, 250V ac/dc	2 P.S.T.	—	OFF	ON	CENTER AND RIGHT	8928K495
6A, 125V ac/dc 3A, 250V dc	2 P.D.T.	— —	ON ON	ON ON	CENTER CENTER AND RIGHT	8373K150 8373K151

HEAVY DUTY KEYLOCK AC RATED SWITCHES SELECTION TABLE

Rating	Circuit	Action	Key Removal Position	Slotted Bushing Length		Type of Termination	Catalog Number	Key Style ①
				mm	inches			
7842 TYPE SERIES								
20A, 120V ac 20A, 240V ac 1 1/2 Hp, 120V ac 2 Hp, 240V ac	2 P.S.T.	OFF-ON (Clockwise) OFF-ON (Clockwise)	OFF Both	14.27 14.27	.562 .562	Screw Screw	7842K2 ② 7842K3 ②	A A
7846 TYPE SERIES								
20A, 120V ac 20A, 240V ac 1 1/2 Hp, 120V ac 2 Hp, 240V ac	2 P.S.T.	OFF-ON-OFF-ON	OFF	12.70	.500	Quick-Connect	7846K1 ②	E

① Key Style: A — 13-5496, E — 13-8173.

② Not CSA Certified.



Mounting Means:

General Purpose

Threaded Bushing —
11.89mm (.468") dia.
Keyway — 1.55-1.70mm
wide x .89-.94mm deep
(.062-.067" wide x
.035-.370" deep)
Hardware Supplied —
1 hexnut (Cat. No. 15-192)
and 1 chamfered dress nut
(Cat. No. 15-994-2) supplied.
Furnished unassembled.

Heavy Duty

7842 Series:
Slotted Bushing —
11.89mm (.468") dia.
Hardware Supplied —
4 terminal screws
(Cat. No. 11-6085-2) and 1
hexnut (Cat. No. 15-2525-58).
Furnished unassembled.
7846 Series:
Hardware Supplied —
2 hexnuts
(Cat. No. 15-2525-59).

Dielectric Withstand:
1000V RMS minimum.

Operating Temperature Range:
-17.8°C to +65.6°C
(0°F to 150°F).

Agency Approvals:
UL Recognized.
CSA Certified
(except where noted).



For more information, contact your
Eaton Sales Representative.

DIMENSIONS APPROXIMATE IN MM (INCHES)

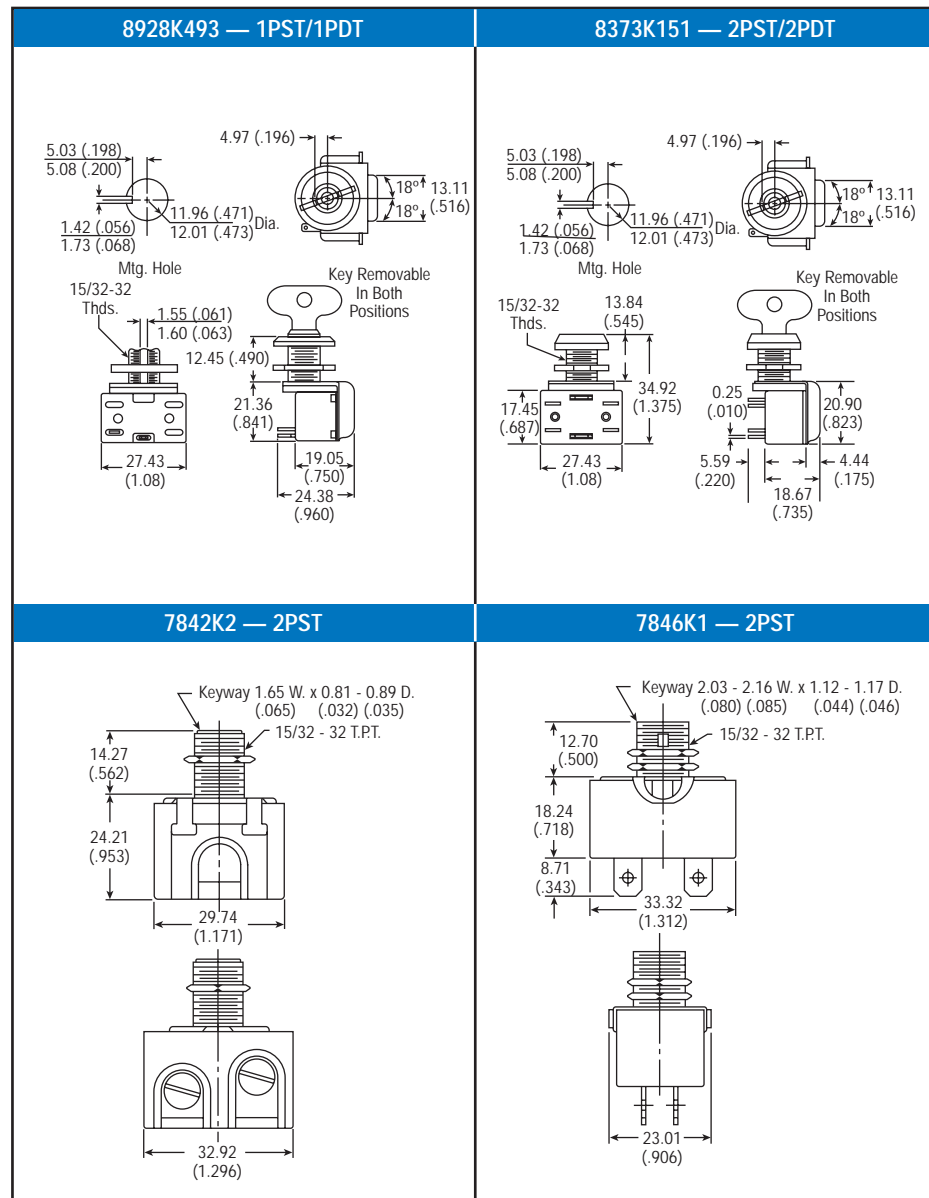

8928K493
General Purpose Keylock



8373K151
General Purpose Keylock



7846K1
Heavy Duty Keylock



7842K2
Heavy Duty Keylock

4 SPECIAL DEVICES AND ACCESSORIES

Utility and Industrial ON-OFF Trigger Switch

DESCRIPTION

Utility

The 140 Series Trigger Switch has a proven record of meeting the demanding requirements for both consumer and industrial tools.

Industrial

The rugged PT Series Trigger Switch is designed for use in high performance, professionally rated power tools.

SPECIFICATIONS

Ratings:

See selection table.

Terminal Types^①:

Utility

Screw Terminals — Brass designed to accept #M3.5 x 5.0 Posidrive (Cat. No. A160-166) terminal screws.

Plug-in Terminals — Accept #18 or #20 AWG Wire^②.

Industrial

Screw Terminals — Copper designed to accept #M6.3 x .6 Thread (Cat. No. A60-117) terminal screws.

Approvals:

UL Recognized.
CSA Certified.
European Approvals.



UTILITY AND INDUSTRIAL ON-OFF TRIGGER SWITCHES SELECTION TABLE

Ratings	Poles and Throw	Mounting	Termination	Trigger Style	Trigger or Lever Material	With Lock-On	Catalog Number
UTILITY							
10A, 125V ac 8 (6)A, 250V ac	2 P.S.T.	Nest	Plug-in Plug-in Screw Screw	In-line	Nylon Nylon Nylon Nylon	Yes	1402 140L2 140CP2 140CPL2
	2 P.S.T.	Nest		In-line		No	
	2 P.S.T.	Nest		In-line		Yes	
	2 P.S.T.	Nest		In-line		No	
INDUSTRIAL							
22A, 125V ac/dc 10A, 250V ac/dc	2 P.S.T.	Flange	Screw Screw	Overhanging	Nylon Nylon	No	PT2A21B PT2A1A11B
	2 P.S.T.	Flange		Overhanging		Yes	

DIMENSIONS APPROXIMATE IN MM (INCHES)

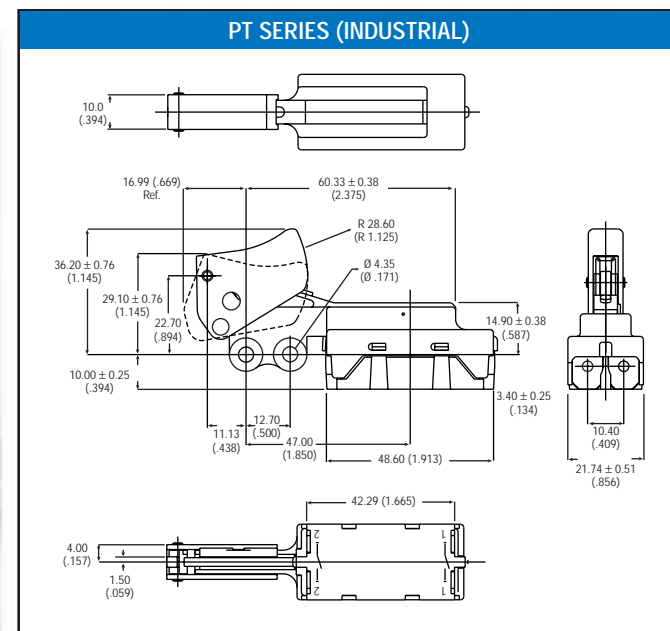
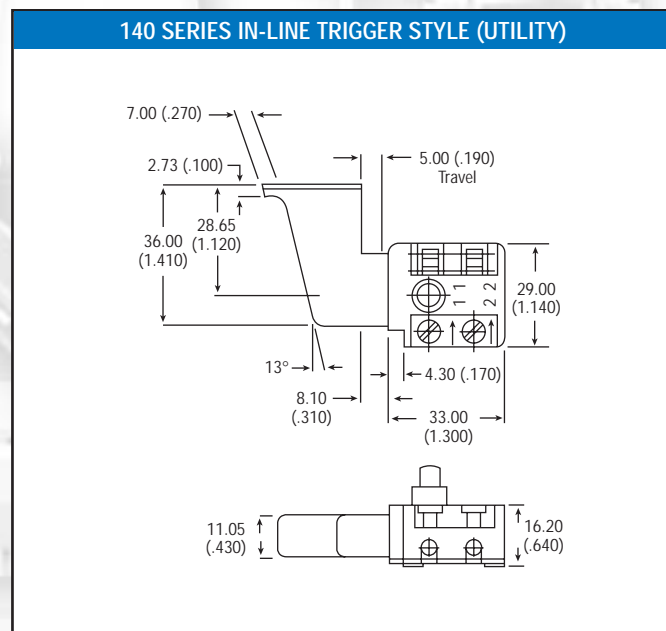

- ① All terminals are furnished unassembled.
- ② Do not insert # 20 Wire after removing # 18 Wire.

AC Variable Speed Control Switches

DESCRIPTION

Our broad range of ac speed control switches are designed to meet the requirements of portable electric power tools for either 125/115V or 250/230V input. Both 1/2 wave (SCR) and full wave (Triac) circuits are available as well as resistor and potentiometer outputs.

SPECIFICATIONS

Circuits:

1PST or 2PST with integrated 1/2 wave or full wave speed control with bypass contact.

Contact Material:

Moveable — Copper.

Stationary — Copper.

Terminal Types:

Jepac Series —

Screw Terminals for Line Connector.

Plug-in Terminals for Motor Connector — 0.5 - 1.5mm/#22-16 AWG Wire.

Plug-in Terminals for capacitor connector for European market.

8600/8622 —

Plug-in terminals for line and motor connector.

Base Material:

Nylon, Phenolic or Polyester.

Dielectric Withstand:

1000V RMS Minimum UL/CSA Requirement.

1500V RMS Minimum European Requirement.

Options:

- Various trigger styles and colors.
- Various reversing lever styles and colors.
- Potentiometer.
- ON/OFF and 2-speed versions.
- Half-wave.
- Full-Wave.
- Lock-on or lock-off — custom lock buttons.
- Actuator adjustment wheel.
- Reversing Switch.

Approvals:

UL Recognized, CSA Certified.

European Approvals (Jepac only).



AC VARIABLE SELECTION TABLE

Ratings	Poles and Throw	Wiring Diagram (See Below)	Termination	Capacitor Connection	Trigger Style	Trigger or Lever Material	With Reversing	Cat. No. With Side Lock Pin
6A, 125V ac	2 P.S.T. 2 P.S.T. 2 P.S.T.	A A A	Plug-in Plug-in Plug-in	No No No	In-line In-line Overhanging	Nylon Nylon Nylon	Yes Yes No	8600K2 8600K3 8622K2
7A, 125V ac	1 P.S.T.	B	Screw Plug-in	Yes	In-line	Nylon	Yes	J1 Series
6A, 250V ac	1 P.S.T.	B	Screw Plug-in	Yes	In-line	Nylon	Yes	J2 Series

8622K2: 4A, 125V. Series 8600 have higher ratings available. Contact your local Eaton Sales Representative.

DIMENSIONS APPROXIMATE IN MM (INCHES)

WIRING DIAGRAMS		8600 SERIES IN-LINE TRIGGER	
Diagram A			
Diagram B			
8622 SERIES OVERHANGING TRIGGER		JEPAC SERIES	



140PHX02
Utility ON/OFF



PT2M21H
Industrial ON/OFF



8600 Series
AC Variable



J1/J2 Series
AC Variable

4 SPECIAL DEVICES AND ACCESSORIES

Industrial Rocker Switch and Locking Rocker

DESCRIPTION

Locking Rocker

This unique switch features a patented internal locking mechanism, which allows the switch to be locked in the off-position to prevent unauthorized or accidental operation. The key to locking or unlocking the switch is a removable paddle rocker cap, which must be inserted in order to move the switch to the "ON" position. The switch can still be turned "OFF."

The locking rocker is ideally suited for such markets as the portable tools, computers, lawn and garden equipment, marine and construction.

Industrial Rocker Switch

This all-plastic rocker switch was originally designed for portable tool applications. It has a high rated Quick-make, Quick-break over center type contact mechanism suitable for either ac or dc service.

SPECIFICATIONS

Ratings:

See selection table.

Circuits:

Industrial Rocker Switch
2PST maintained action.

Contact Mechanism:

Locking Rocker
Slow-make/Slow-break contact mechanism.

INDUSTRIAL ROCKER SWITCH SELECTION TABLE

Rating	Poles and Throw	Circuit with Rocker in			BASE CIRCUIT SEE PAGE 4.28	Mounting	Screw Terminals Catalog Number
		UP Position	CENTER Position	DOWN Position			
INDUSTRIAL ROCKER SWITCH		INDUSTRIAL ROCKER SWITCH					
16A, 125V ac/dc 8A, 250V ac/dc 1 Hp, 125V ac/dc	2 P.S.T.	ON	NONE	OFF	C	Flush	8630K50

LOCKING ROCKER SELECTION TABLE

Rating ①	Poles and Throw	Circuit with Rocker in			BASE CIRCUIT SEE PAGE 4.28	Catalog Number
		UP Position	CENTER Position	DOWN Position		
WITHOUT PALM GUARD FEATURE		WITHOUT PALM GUARD FEATURE				
20A, 125V ac 20A, 250V ac 1Hp, 125V ac 2 Hp, 250V ac	1 P.S.T.	ON	NONE	OFF	A	8166K27
	1 P.D.T.	ON	NONE	ON	B	8166K28
20A, 125V ac 20A, 250V ac 1Hp, 125V ac 2 Hp, 250V ac	2 P.S.T.	ON	NONE	OFF	C	8166K25
	2 P.D.T.	ON	NONE	ON	D	8166K26
WITH PALM GUARD FEATURE		WITH PALM GUARD FEATURE				
20A, 125V ac 20A, 250V ac 1Hp, 125V ac 2 Hp, 250V ac	1 P.S.T.	ON	NONE	OFF	A	8166K23
	1 P.D.T.	ON	NONE	ON	B	8166K24
20A, 125V ac 20A, 250V ac 1Hp, 125V ac 2 Hp, 250V ac	2 P.S.T.	ON	NONE	OFF	C	8166K21
	2 P.D.T.	ON	NONE	ON	D	8166K22

① Ratings listed for 125V ac also apply at 28V dc. Also supplied with a 20A, 277V ac rating as standard.



Butt action contact mechanism designed specifically for use on ac and low voltage dc applications.

Contact Material:

Locking Rocker

Movable — Silver plated copper with cad-oxide contact face button.

Stationary — Copper with cad-oxide contact face button.

Industrial Rocker Switch

Movable — Copper silver plated.

Stationary — Bronze silver plated.

Terminal Types:

Locking Rocker

.250" spade terminals are standard.

Industrial Rocker Switch

Screw Terminals — Brass designed to accept #5-40 x 1/4" binding head (Cat. No. 811-14) screws. Furnished unassembled.

Mounting Means:

Industrial Rocker Switch
Flush — Four holes (.098") dia. Designed for use with #4 plastite screw.

Rocker Material:

Locking Rocker

Custom styled, red thermoplastic rocker key with "REMOVE TO LOCK" across the top of the key in raised letters.

Dielectric:

Locking Rocker
1000V RMS minimum.

Approvals:

UL Recognized.
CSA Certified.
Contact your local Eaton Sales Representative for Selection Information and Optional Features.



DIMENSIONS APPROXIMATE IN MM (INCHES)

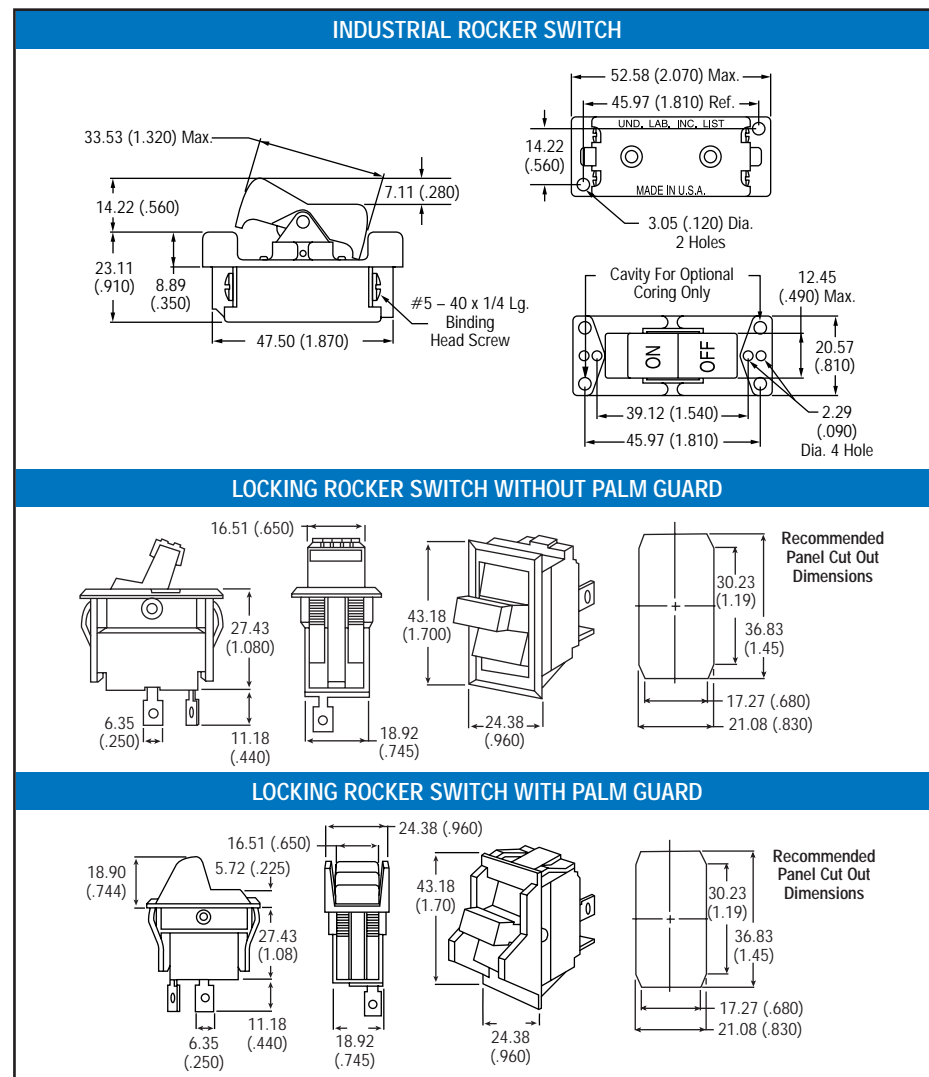

8630K50
Industrial Rocker



8166K27
Locking Rocker without Palm Guard



8166K21
Locking Rocker with Palm Guard

4 SPECIAL DEVICES AND ACCESSORIES

Sump Pump Switches — AC Rated

These completely molded, ruggedly constructed switch assemblies are designed specifically for sump pump and liquid level applications. All series feature Quick-make/Quick-break mechanisms with snap acting butt contacts. They provide high reliability and long life at an economical cost. Currently used in many pedestal and submersible type residential sump pumps, these switches can be supplied to operate with float type or weight type actuators.

SPECIFICATIONS

Ratings:

See selection table.

Electrical Life:

Life expectancy in excess of 100,000 on-off cycles.

Circuits:

2PST.

Maintained — For use with float type actuators.

Momentary — For use with weight type actuators.

Contact Mechanism:

Quick-make/Quick-break snap acting butt contact.

Contact Materials:

Movable — Fine silver.

Stationary — Fine silver.

Termination:

All Types — 2 male tabs, 6.33 x .81mm (.250 x .032") as line connections.

Pedestal Types — 2 additional wire leads, 95.25mm (3.750") long with 6.33mm (.250") female connectors.

Submersible Types — 2 additional wire leads, 95.25mm (3.750") long, with approximately (.085") dia. female pin connectors (AMP #42745-1).

General Purpose Type — 2 additional wire leads, 95.25mm (3.750") long, stripped 10.31mm (.406") for connecting with wire nuts.

Termination Materials:

Brass.

Mounting Means:

Pedestal Types — Holes in flange to fit most motor heads.

General Purpose Types — Universal strap mountings for pedestal pipe, discharge pipe or motor head O.D.

Submersible Types — 2 holes for mounting inside of submersible pump housing.

Housing and Operating Lever Material:

Thermoplastic — Meets impact and flammability requirements of UL Specification #746 as applied in UL Specification #778.

Dielectric Withstand:

2000V RMS for 60 seconds.

Operating Temperature Range:

-17.8°C to +65.6°C (0°F to + 150°F).

Operating Force:

Float Activated Switches —

2-8 ounces to open and close contacts.

Submersible Switches —

8-12 ounces to open and close contacts.

Weight Activated Switches —

2.8 ounces minimum to "ON".

12.2 ounces maximum to "OFF".

Approvals:

UL Recognized, CSA Certified.

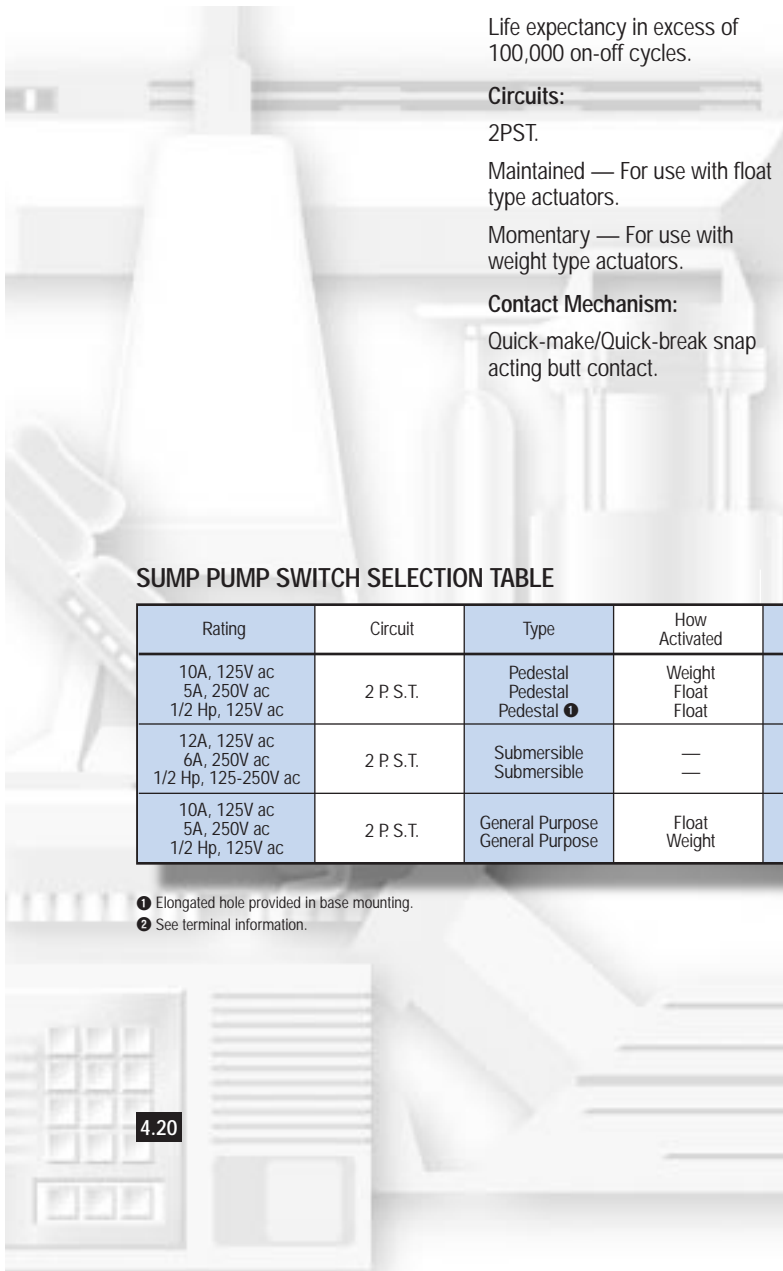

SUMP PUMP SWITCH SELECTION TABLE

Rating	Circuit	Type	How Activated	Housing Profile	Lever Type	Terminal Connector ②	Lever Position For "ON"	Catalog Number
10A, 125V ac 5A, 250V ac 1/2 Hp, 125V ac	2 P.S.T.	Pedestal Pedestal Pedestal ①	Weight Float Float	High High High	Long Long Long	.250" Female .250" Female .250" Female	Up Up Up	8980K44 8980K49 8980K50
12A, 125V ac 6A, 250V ac 1/2 Hp, 125-250V ac	2 P.S.T.	Submersible Submersible	— —	Low Low	Short Short	Pin Type Pin Type	Down Up	8980K55 8980K147
10A, 125V ac 5A, 250V ac 1/2 Hp, 125V ac	2 P.S.T.	General Purpose General Purpose	Float Weight	— —	Long Long	2 Wire Leads 2 Wire Leads	Up Up	8980K148 8980K60

① Elongated hole provided in base mounting.
② See terminal information.



DIMENSIONS APPROXIMATE IN MM (INCHES)

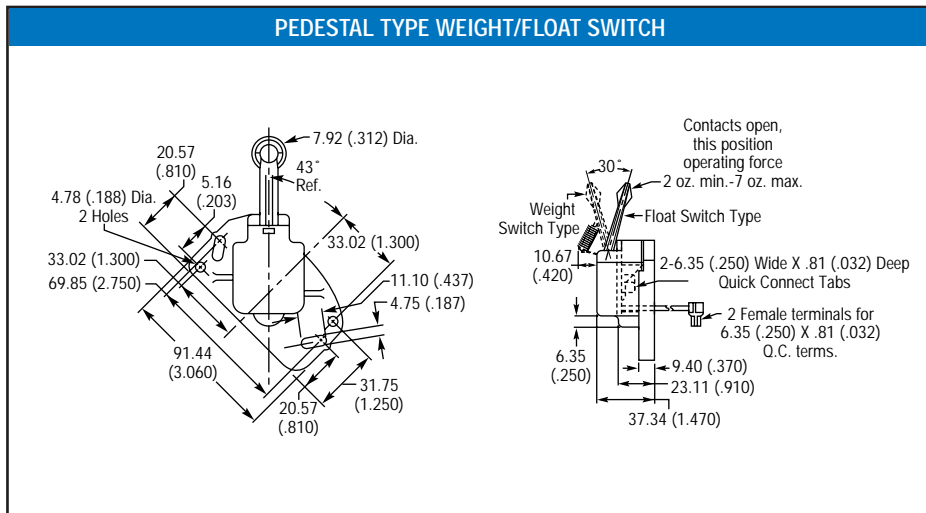

8980K44
Pedestal

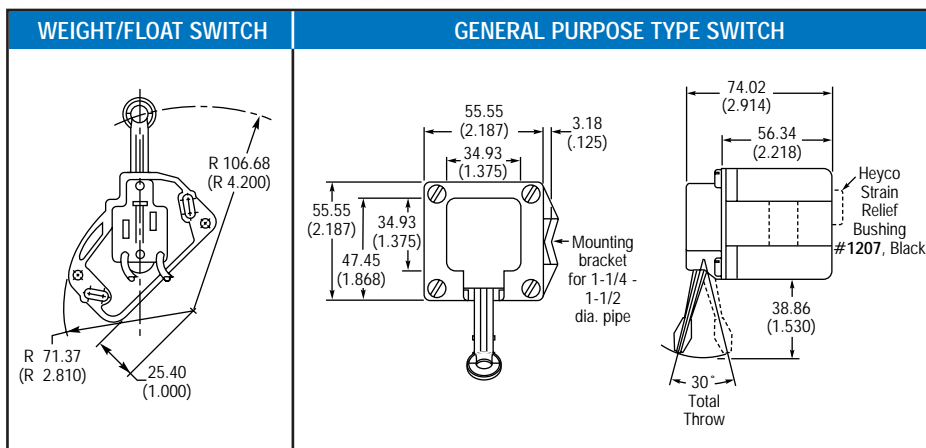

8980K55
Submersible

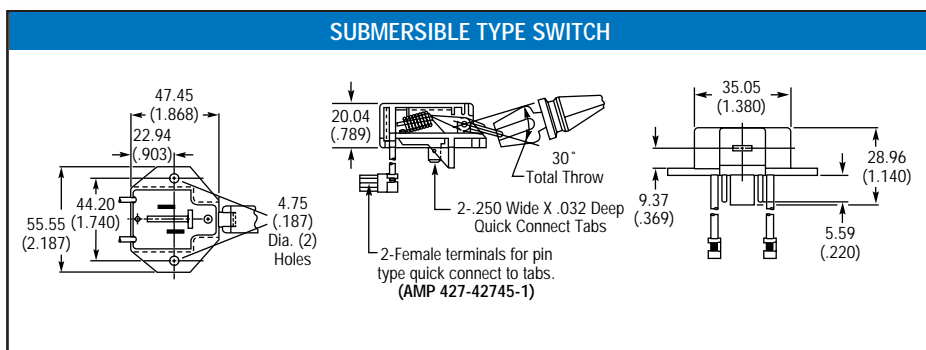

8980K60
General Purpose

4

4 SPECIAL DEVICES AND ACCESSORIES

Mounting Hardware for One Hole Mounting Switches

DESCRIPTION

All bushing mounted switches are furnished with two mounting nuts. One nut is mounted behind the

panel to prevent the bushing sleeve from being distorted if the front panel is overtightened. Eaton accepts no responsibility for

damage to switches mounted without the backup nuts.

MOUNTING HARDWARE SELECTION TABLE (BOLD FACE TYPE INDICATES ITEMS NORMALLY IN DISTRIBUTOR STOCK)

Size	Description	Material	Dimensions mm (inches)				Catalog Number
			Thickness (Dim. A)	Inside Diameter (Dim. B)	O.D. or Dim. Across Flats (Dim. C)	Dim. Across Corners (Dim. D)	
MOUNTING NUTS							
3/8-27	Hexagon Locknut	Nickel Plated Brass	3.18 (.125)	—	14.27 (.562)	15.88 (.625)	15-2526-2
3/8-24		Bright Nickel Plated Brass	3.18 (.125)	—	14.27 (.562)	15.88 (.625)	15-2525-6
11/32-32		Nickel Plated Brass	1.60 (.063)	—	12.01 (.473)	13.49 (.531)	15-2525-2
15/32-32	Hexagon Locknut	Zinc-Chromate Treated	1.91 (.075)	—	15.88 (.625)	—	15-192
		Bright Nickel Plated Brass	1.98 (.078)	—	13.87 (.546)	15.88 (.625)	15-2525-58
		Nickel Plated Brass	1.98 (.078)	—	13.87 (.546)	15.88 (.625)	15-2525-59
		Zinc-Chromate Treated	4.76 (.188)	19.89 (.783)	25.80 (1.125)	—	15-2528-2
	Hexagon Facenut	Nickel Plated Brass	1.98 (.078)	—	14.27 (.562)	16.66 (.656)	15-966-2
		Semi-Lustre Nickel Plated Brass	1.98 (.078)	—	14.27 (.562)	16.66 (.656)	15-966-6
	Knurled Facenut	Bright Nickel Plated Brass	1.68 (.066)	—	14.27 (.562)	—	15-124F1
		Black Cupric Oxide Plated Brass	1.68 (.066)	—	14.27 (.562)	—	15-124F5
Nickel Plated Brass		2.77 (.109)	—	15.88 (.625)	—	15-90	
Chamfered Dress Nut	Bright Nickel Plated Brass	3.84 (.151)	7.92 (.312)	17.45 (.687)	—	15-994-2	
Standard Knurl Nut with Shoulder	Nickel Plated Brass	2.77 (.109)	—	15.06 (.593)	—	15-2534-14	
Dress Nut	Satin Chrome Plated Brass	3.18 (.125)	—	14.27 (.562)	—	15-2523-4	
		Black Nylon	4.75 (.187)	9.91 (.390)	16.26 (.640)	—	15-1048-3
	Knurled Dress Nut	Chrome Plated Brass	4.75 (.187)	7.92 (.312)	16.26 (.640)	—	15-189-5
3/4-32	Hexagon Facenut	Nickel Plated Steel	2.36 (.093)	—	23.80 (.937)	27.38 (1.078)	15-1043
#8-40	Hexagon Locknut and Facenut	Nickel Plated Steel	1.52 (.060)	—	6.22 (.245)	5.49 (.216)	15-1047
MOUNTING WASHERS AND LOCKING RING							
For 9.53 (.375") Bushing	Flat Washer	Steel	0.69 (.027)	9.65 (.380)	18.29 (.720)	—	16-4183-3
For 9.98 (.393") Bushing		Stainless Steel	1.24 (.049)	3.05 (.120)	7.14 (2.810)	—	16-4183-6
For 15/32 Bushing	Plain Washer	Cadmium Plated Steel	0.79 (.031)	12.29 (.484)	19.05 (.750)	—	16-1382
	Internal Tooth Lockwasher	Cadmium Plated Steel	0.53 (.021)	11.96 (.471)	15.06 (.593)	—	16-3557
	Locking Ring	Zinc Plated Steel	1.02 (.040)	12.07 (.475)	18.24 (.718)	—	29-761-5

Hardware items are sold for use with Eaton switches only. Minimum ordering quantity on all items is 100.

DIMENSIONS APPROXIMATE IN MM (INCHES)

HEXAGON LOCKNUTS OR FACENUTS	KNURLED FACENUT	KNURLED NUT WITH SHOULDER	CHAMFERED DRESS NUT CATALOG NO. 15-994-2	KNURLED DRESS NUT CATALOG NO. 15-189-5
KNURLED DRESS NUT CATALOG NO. 15-1048-3	DRESS NUT CATALOG NO. 15-2523-4	PLAIN WASHER	INTERNAL TOOTH LOCKWASHER	LOCKING RING



APPLICATION TABLE

Switch Catalog Number	Catalog Numbers					Switch Catalog Number	Catalog Numbers				
	Locknut	Facenut	Lockwasher	Locking Ring	Terminal Screws		Locknut	Facenut	Lockwasher	Locking Ring	Terminal Screws
APPLICATION TABLE						APPLICATION TABLE					
7070-7073 7320-21	15-192 15-192	15-124F1 15-966-2	— —	— —	811-2 811-14	8130-8166 8194	— —	— —	— —	— —	811-2 11-1766
7300-7317 7360-61 7402	— 15-192 15-192	15-966-6 15-966-2 15-966-2	— — —	— — —	811-2 811-161 11-1766	8261-62 8280, 90, 95 8282, 83, 92, 97	— 15-192 15-192	15-966-6 15-124F1 15-124F1	16-886 — —	— — —	— 11-26 11-26
7500-7510 7546-7548 7560-71 7576	15-192 15-192 15-192 15-192	15-124F1 15-124F1 15-124F1 15-124F1	— — — —	— — — —	811-2 811-2 811-2 11-1369	8307 8337 8370-75	— — 15-192	— — 15-124F1	— — —	— — —	11-26 811-161 11-26
7580-87 7590-97,99 7630-32 7660-7670 7690-95	15-192 15-192 15-192 — 15-192	15-124F1 15-124F1 15-124F1 15-966-2 15-124F1	— — — 16-886 —	— — — 29-761 —	811-2 811-2 811-2 11-1893 811-2	8381-82,86,91,96 8406 8410 8411, 18	15-192 — — 15-192	15-124F1 — — 15-966-2	— — — —	— — — —	11-26 11-26 811-7206 811-7206
7700-05 7800-7805 7810 7811 7812-7813	15-192 15-192 — — —	15-966-2 15-124F1 — — —	— — — — —	— — — — —	811-2 811-2 11-6106 11-6074-4 11-6074-11	8432-35 8440 8442-45 8448	15-192 15-192 15-192 15-192	15-124F1 15-124F1 15-124F1 15-966-2	— — — —	— — — —	811-2 11-26 811-2 811-2
7814-16 7818 7835-36 7842K2, K3	— — 15-192 15-2525-58	15-1043 — 15-124F1 —	— — — —	— — — —	11-6100 11-6074-4 — 11-6085-2	8690	15-192	15-966-2	—	—	811-7248
7846 7990-92 8004-05	15-2525-59 15-192 —	— 15-966-2 —	— — —	— — —	— 811-2 811-2	8800-8860 8928K478-482 8928K492-495	— 15-192 15-192	15-966-6 15-124F1 15-994-2	16-886 — —	29-761 — —	11-1893 11-26 —
8054-8057	—	—	—	—	811-2	8980 SA37	— 15-192	— —	— —	— —	② —

4

① The Application Table lists the original equipment hardware supplied.
 ② Contact Customer Service Center. See back cover.

Snap-On Pushbutton Caps — Standard

DESCRIPTION

These snap-on pushbutton caps are made of molded plastic for use with grooved style switches. They are ordered separately for user assembly.

SELECTION TABLE

Description	Button Diameter mm (inches)	Catalog Number
Black Molded	15.88 (.625)	53-3338
Red Molded	15.88 (.625)	53-3338-2

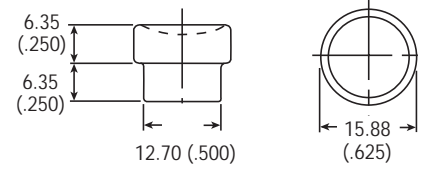
CAT. NO. 35-3338	CAT. NO. 53-3338-2
	

4 SPECIAL DEVICES AND ACCESSORIES

Rotary Keylock Brackets — Security Tumbler Type

DESCRIPTION

This series of rotary keylock is designed for use in security applications. They provide a simple method of converting 1 and 2 pole toggle switches. For use with 2 or 3 position switches.

SPECIFICATIONS

Bushing:
7/8" Dia., 24 threads/inch.

Mounting Hardware and Keys:

1 hexagon locknut (Cat. No. 15-2528-2) and 1 bright chrome plated dress nut (Cat. No. 15-2528-2). Furnished unassembled. Plus 2 keys (Cat. No. 13-8171).

Finish:

Lock Bushing — Diecast zinc.
Lock Barrel and Dress Nut — Chrome plated brass.
Keys — Brass.

KEYS SELECTION TABLE

Where Used	Catalog No.
Key removable in counter-clockwise position	8980P25
Key removable in center position	8980P26
Key removable in clockwise position	8980P27
Key removable in either extreme position	8980P28

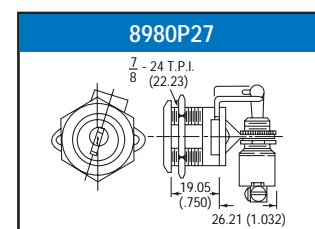

Keys For Locking Switches

DESCRIPTION

Additional keys may be ordered from the table below. Key styles below match those listed for specific switches in the keylock section on pages 4.14.

KEYS SELECTION TABLE

Where Used	Catalog No.
General Purpose & Heavy Duty Series	13-5496
Security Locking Bracket	13-8171
Heavy Duty Series	13-8173

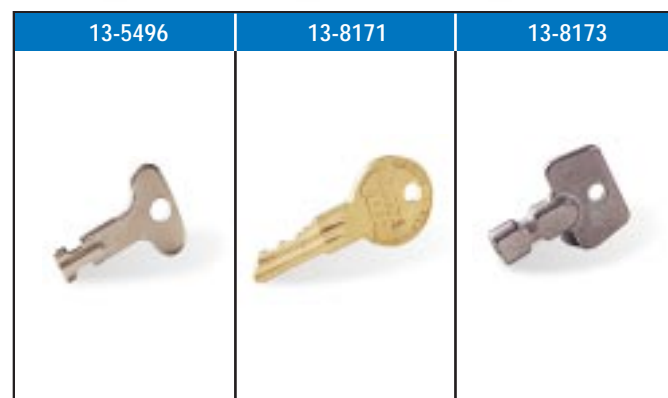

Decorator Facenuts

SELECTION TABLE

Type	Color	Catalog Number
Knurled Facenuts	Black	15-1048-3
	Brite Clear	15-1048-7
Beveled Facenuts	Brite Black	15-1049-3
	Brite Clear	15-1049-7

Decorator Facenuts for designer line and 15/32" bushing switches, 15/32-32 thread.

DIMENSIONS APPROXIMATE IN MM (INCHES)

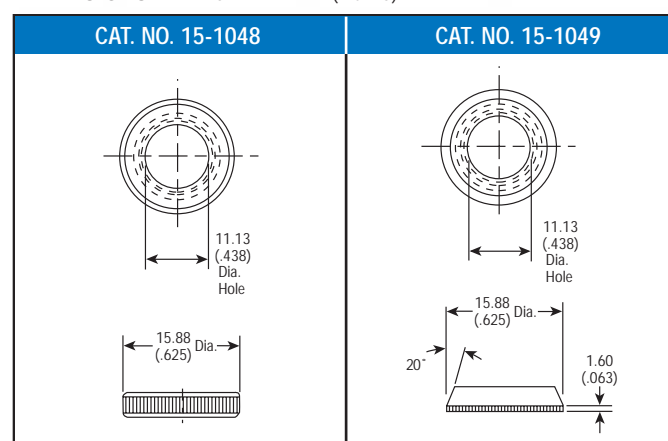

Dust Protection Cap Nut Assembly

The dust protection assembly (Cat. No. 8916K693) consists of neoprene washer and cap nut. It is recommended for use with tool handle switches that have a 15/32" bushing (Cat. No. 7320-7322, 7360-7361).

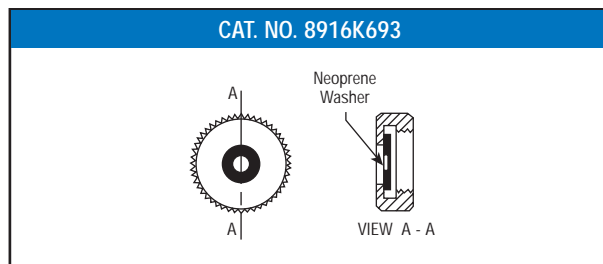

Replacement Terminal Screws

SELECTION TABLE ●

Screw Size	Catalog Number ●
#5-40 x 1/8"	11-1117
#5-40 x 5/32"	11-26
#5-40 x 3/16" Binding Head	811-7206
#5-40 x 1/4" Binding Head	811-14
#6-32 x 3/16" Binding Head	811-2
#6-32 x 1/4" Binding Head	811-161
#6-32 x 1/4" Binding Head	811-7248
#6-32 x 1/4" Pan Head — Brass	11-1893
#6-32 x 3/8" Binding Head	811-129
#8-32 x 3/16" Binding Head	11-1618
#8-32 x 1/4"	11-1369
#8-32 x 1/4"	811-408-2
#8-32 x 3/8" Binding Head	11-1766
#8-32 x 3/8" Binding Head	11-6074-4
#6-32 x 7/32" Binding Head	11-6085-2

● Hardware items are sold for use with Eaton Switches only.

Indicating Plates

SELECTION TABLE ●

Keyway Location	Marking		Material	Finish	Catalog Number
	Opposite Keyway	Keyway Side			
	ON	OFF	.320" Steel	Burnished Nickel	30-5632-4
	ON	OFF	.032" Steel	Burnished Nickel	30-5632-13

● Indicating plates for 15/32" bushing mounted switches.

Panel Seal

- Prevents moisture and contaminants from entering panel enclosure.
- Behind panel mounting.
- Stainless steel cup washer assures proper seating of silicone rubber seal.
- Seal withstands 20 psi water pressure.
- Cat. No. 32-341.

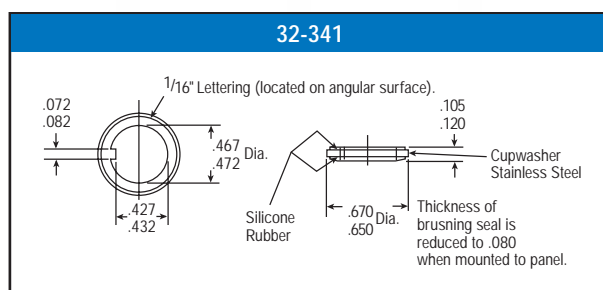

EATON

4 SPECIAL DEVICES AND ACCESSORIES

Accessories for EURO/SR, FULL SIZE, ESPORT and NGR Rockers

DIMENSIONS APPROXIMATE IN MM (INCHES)

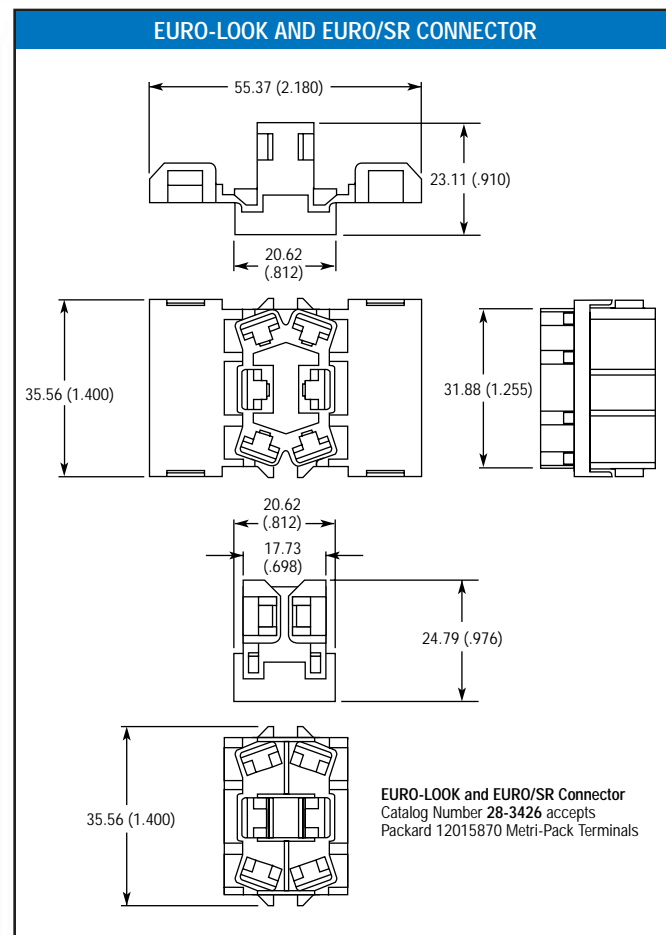
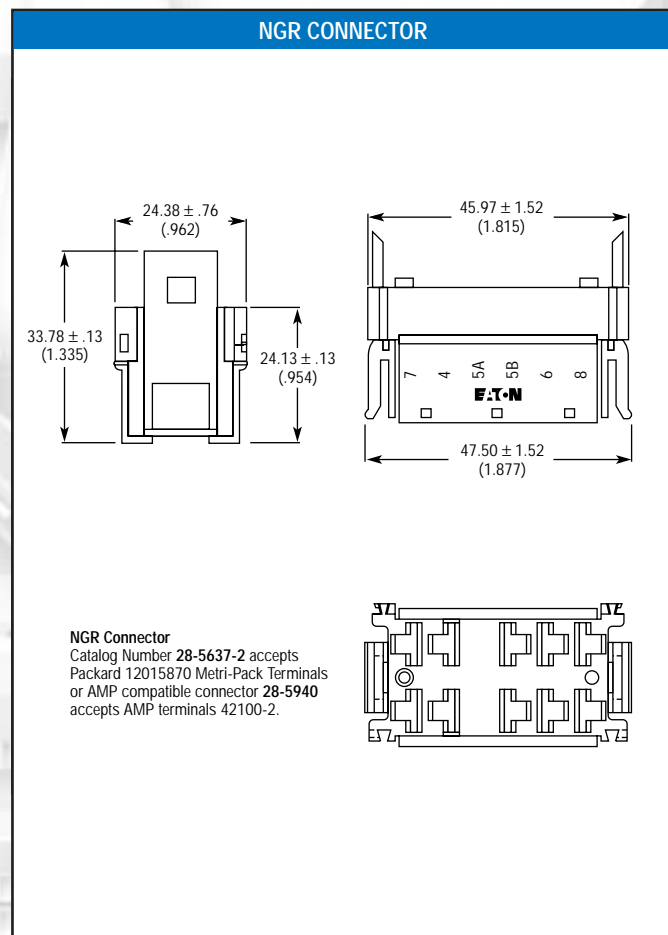
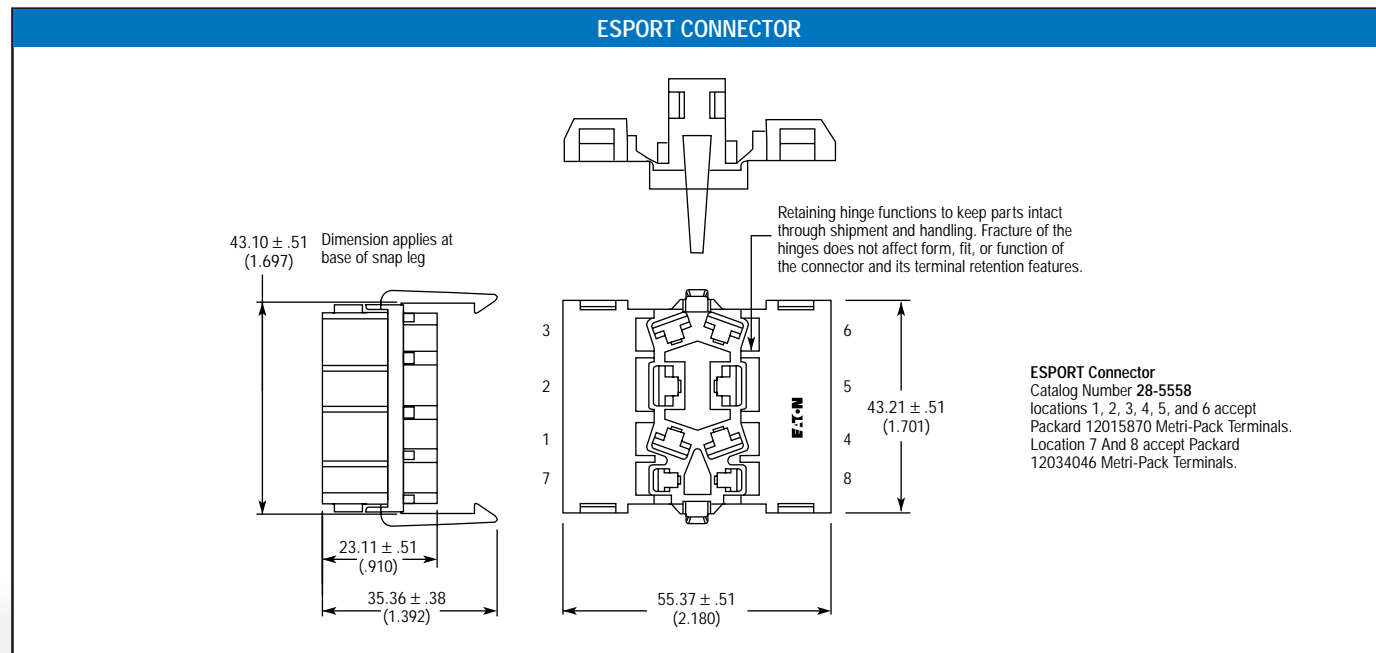



DIMENSIONS APPROXIMATE IN MM (INCHES)

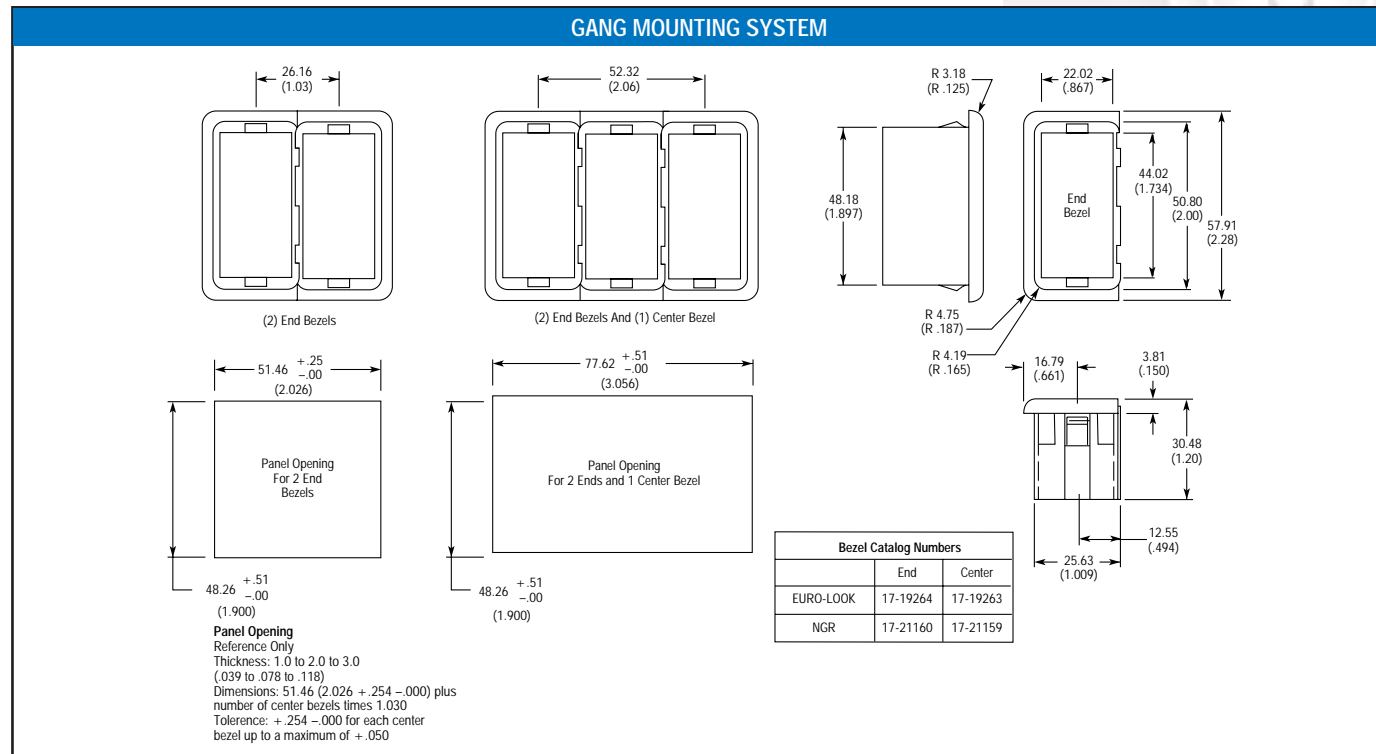

4

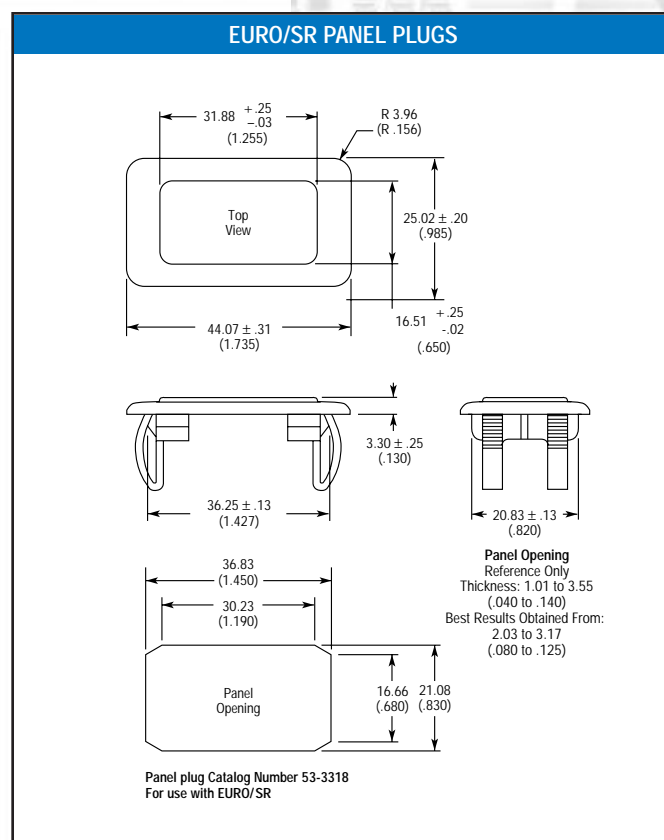
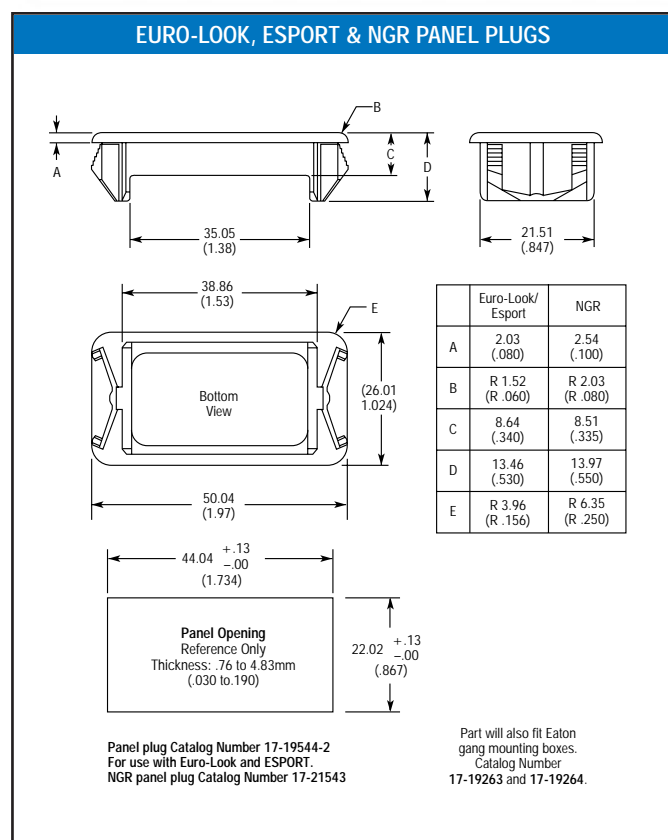

4 SPECIAL DEVICES AND ACCESSORIES

Rocker, Toggle and Pushbutton Switch Circuit Diagrams

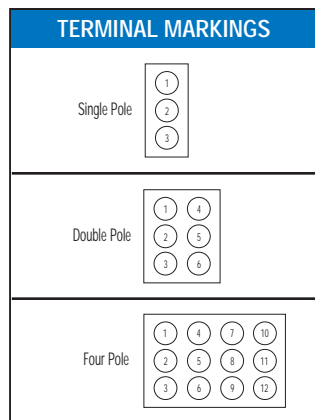

TERMINAL IDENTIFICATION

When specified on order, switches will have the terminals identified as shown in the illustration at right. Terminal markings will be ink-stamped on the side of the switch case and unused terminal positions will not be identified.

All views are rear of switch with keyway or flat down as applicable. Terminal numbers 2, 2 & 5, and 5 & 8 are considered inboard terminals for single, two and four pole switches respectively. All others are considered outboard.

LEGENDS

ROCKER, TOGGLE AND PUSHBUTTON SWITCH LEGEND	
•	Contact Terminal — will make contact with switch lever
○	Isolated Terminal — does not make contact with lever
⌋	Center terminal and switch lever
⊗	Bulb
↔	Momentary Contact
•	Denotes mechanical contact portion

See page 4.29 for 92, Midsize and Elite Circuit Diagrams.
See pages 1.41-1.45 for NGR Circuit Diagrams.

"THREE INDEPENDENT" ON-ON-ON CIRCUIT DIAGRAM

Note: For switch modified with "Three Independent" ON-ON-ON Special Circuit. External Jumpers are required. Converts 2PDT to 1P3T or 4PDT to 2P3T. User to connect wiring per instructions given below.

Connection Points	Single Pole
Connect Common to Terminals	2
Connect Circuit "A" to Terminals	6
Connect Circuit "B" to Terminals	4
Connect Circuit "C" to Terminals	1

3 "ON" Independent	No. of Poles	Circuit with Lever in		
		UP Position	CENTER Position (Maintained)	DOWN Position (Keyway)
1P3T	1	Circuit A	Circuit B	Circuit C

ROCKER, TOGGLE AND PUSHBUTTON CIRCUIT DIAGRAMS

Circuit Letter	Schematic	Circuit Letter	Schematic
A (1 P.S.T.)		I (2 Circuit) ⑤	
B (1 P.D.T.)		J (1 P.S.T.)	
C (2 P.S.T.)		K (1 P.D.T.)	
D (2 P.D.T.)		L (2 P.S.T.)	
E (4 P.S.T.) ①		M (2 P.S.T.)	
F (4 P.D.T.) ②		N ③ (2 P.D.T.)	
G ④ (1 P.S.T.)		P (1 P.D.T.)	
H ⑤ (1 P.D.T.)		Q ⑥ (2 Circuit)	

- ① Poles 11 and 12 may be eliminated for 3 pole devices.
- ② Poles 10, 11 and 12 may be eliminated for 3 pole devices.
- ③ Dependent Lamp.
- ④ Independent Lamp.
- ⑤ Two Circuit — Indicates a special type of double throw switch in which the two circuits being controlled may be independent of each other.
- ⑥ For 206 Series, an additional lamp is available.
- ⑦ Available in 1PDT or 2PDT.

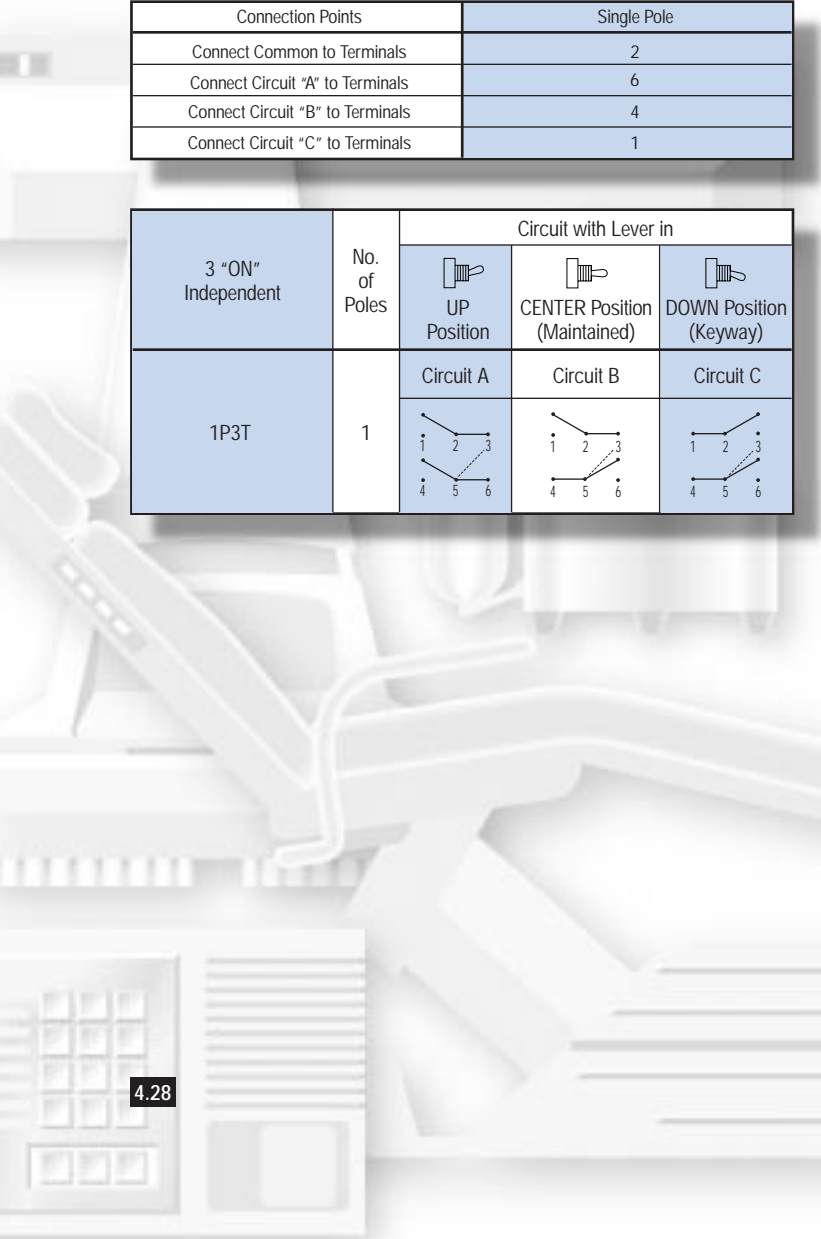



Rocker Switch Circuit Diagrams

92, MIDSIZE AND ELITE SERIES CIRCUIT DIAGRAMS

Circuit Number (Circuit Designation)	Schematic	Circuit with Rocker in			Circuit Number (Circuit Designation)	Schematic	Circuit with Rocker in		
		UP Position	CENTER Position	DOWN Position			UP Position	CENTER Position	DOWN Position
NON-ILLUMINATED									
1 (1 P.S.T.)		ON	NONE	OFF	10 (2 P.S.T.)		ON	NONE	OFF
2 (1 P.S.T.)		ON	NONE	OFF	11 (2 P.S.T.)		ON*	NONE	OFF
3 (1 P.S.T.)		ON*	NONE	OFF	12 (2 P.S.T.)		ON	NONE	OFF*
4 (1 P.S.T.)		ON	NONE	OFF*	13 (2 P.D.T.)		ON	NONE	ON
5 (1 P.D.T.)		ON	NONE	ON	14 (2 P.D.T.)		ON	OFF	ON
6 (1 P.D.T.)		ON	OFF	ON	15 (2 P.D.T.)		ON	NONE	ON*
7 (1 P.D.T.)		ON	NONE	ON*	16 (2 P.D.T.)		ON*	OFF	ON
8 (1 P.D.T.)		ON*	OFF	ON	17 (2 P.D.T.)		ON*	OFF	ON*
9 (1 P.D.T.)		ON*	OFF	ON*					
ILLUMINATED									
18 (1 P.S.T.)		ON	NONE	OFF	26 (1 P.D.T.)		ON	OFF	ON*
19 (1 P.S.T.)		ON	NONE	OFF	27 (2 P.S.T.)		ON	OFF	ON*
20 (1 P.S.T.)		ON	NONE	OFF	28 (2 P.S.T.)		ON	NONE	OFF
21 (1 P.S.T.)		ON*	NONE	OFF	29 (2 P.S.T.)		ON	NONE	OFF
22 (1 P.S.T.)		ON	NONE	OFF*	30 (2 P.S.T.)		ON*	NONE	OFF
23 (1 P.D.T.)		ON	NONE	ON	31 (2 P.S.T.)		ON	NONE	OFF*
24 (1 P.D.T.)		ON	OFF	ON	32 (Indicator)				
25 (1 P.D.T.)		ON	NONE	ON*					

* Momentary contact.
 ① Terminal numbers 1, 2 and 3 denotes single pole base.
 Terminal numbers 11, 12, 13, 24, 25 and 26 denotes double pole base.
 ② Single pole in double pole base with lamp independently wired.
 ③ Double Pole — Independently wired lamp.

X-ON Electronics

Largest Supplier of Electrical and Electronic Components

Click to view similar products for [Keylock Switches](#) category:

Click to view products by [Eaton](#) manufacturer:

Other Similar products are found below :

[89496-09](#) [89638-00](#) [58J9A90-01C02N](#) [719-0022-020](#) [719-0122-000](#) [719-0201-000](#) [719-0202-000](#) [719-0702-000](#) [84800-04](#) [88521-00](#)
[GKNC33L](#) [GKNC3L](#) [PVA2OAH5](#) [14-136.025K](#) [14-235.022K](#) [AS6H-2K2A](#) [AS6M-2K1B](#) [1571487-1](#) [HW4K-2BF20](#) [JD7510H](#)
[K6SLYE1.55NL327SD](#) [KH3C-20C](#) [89638-05](#) [A028301](#) [A165K-J2AL-2](#) [A165K-J2M-2](#) [A165K-J3AMR](#) [A165K-J3M](#) [205389 \(PAYGUARD](#)
[BUTTON PAD\)](#) [2SWK131AL102](#) [30PA39-AML](#) [LW6MJ-2C64WWB](#) [AS6M-2K1A](#) [51-401.036D](#) [51-401.036K](#) [51-414.036D](#) [HW1K-](#)
[3HF20](#) [4370039](#) [Y1112-2027CLFT](#) [4B01H322NCFQ](#) [51-155.025D](#) [51-195.025D](#) [51-378.AD](#) [51-404.036D](#) [51-405.036D](#) [51-415.036D](#) [1-](#)
[1437597-8](#) [86945-05](#) [88169-05](#) [719-0204-000](#)