



ELECTRONICS, INC.
 44 FARRAND STREET
 BLOOMFIELD, NJ 07003
 (973) 748-5089

NTE396 Silicon NPN Transistor Power Amplifier & High Speed Switch (Compl to NTE397)

Absolute Maximum Ratings:

Collector–Emitter Voltage, V_{CEO}	350V
Collector–Base Voltage, V_{CBO}	450V
Emitter–Base Voltage, V_{EBO}	7V
Continuous Collector Current, I_C	1A
Base Current, I_B	500mA
Total Device Dissipation ($T_A = +25^\circ\text{C}$), P_D	1W
Derate Above 25°C	5.7mW/ $^\circ\text{C}$
Total Device Dissipation ($T_C = +25^\circ\text{C}$), P_D	5W
Derate Above 25°C	28.6mW/ $^\circ\text{C}$
Operating Junction Temperature Range, T_J	-65° to $+200^\circ\text{C}$
Storage Temperature Range, T_{stg}	-65° to $+200^\circ\text{C}$
Thermal Resistance, Junction–to–Case, R_{thJC}	35°C/W
Thermal Resistance, Junction–to–Ambient, R_{thJA}	175°C/W

Electrical Characteristics: ($T_A = +25^\circ\text{C}$ unless otherwise specified)

Parameter	Symbol	Test Conditions	Min	Typ	Max	Unit
OFF Characteristics						
Collector–Emitter Sustaining Voltage	$V_{CEO(sus)}$	$I_C = 50\text{mA}$, $I_B = 0$, Note 1	350	–	–	V
Collector Cutoff Current	I_{CEO}	$V_{CE} = 300\text{V}$, $I_B = 0$	–	–	20	μA
	I_{CEX}	$V_{CE} = 450\text{V}$, $V_{BE} = 1.5\text{V}$	–	–	500	μA
	I_{CBO}	$V_{CB} = 360\text{V}$, $I_E = 0$	–	–	20	μA
Emitter Cutoff Current	I_{EBO}	$V_{EB} = 6\text{V}$, $I_C = 0$	–	–	20	μA
ON Characteristics (Note 1)						
DC Current Gain	h_{FE}	$I_C = 2\text{mA}$, $V_{CE} = 10\text{V}$	30	–	–	
		$I_C = 20\text{mA}$, $V_{CE} = 10\text{V}$	40	–	160	
Collector–Emitter Saturation Voltage	$V_{CE(sat)}$	$I_C = 50\text{mA}$, $I_B = 4\text{mA}$	–	–	0.5	V
Base–Emitter Saturation Voltage	$V_{BE(sat)}$	$I_C = 50\text{mA}$, $I_B = 4\text{mA}$	–	–	1.3	V

Note 1. Pulse Test; Pulse Width $\leq 300\mu\text{s}$, Duty Cycle $\leq 2\%$.

CAUTION: The sustaining voltage ***must not*** be measured on a curve tracer.

Electrical Characteristics (Cont'd): ($T_A = +25^\circ\text{C}$ unless otherwise specified)

Parameter	Symbol	Test Conditions	Min	Typ	Max	Unit
Small-Signal Characteristics						
Current Gain-Bandwidth Product	f_T	$I_C = 10\text{mA}, V_{CE} = 10\text{V}, f = 50\text{MHz}$	15	–	–	MHz
Output Capacitance	C_{obo}	$V_{CB} = 10\text{V}, I_E = 0, f = 1\text{MHz}$	–	–	10	pF
Input Capacitance	C_{ibo}	$V_{CB} = 5\text{V}, I_C = 0, f = 1\text{MHz}$	–	–	75	pF
Small-Signal Current Gain	h_{fe}	$I_C = 5\text{mA}, V_{CE} = 10\text{V}, f = 1\text{MHz}$	25	–	–	
Real Part of Input Impedance	$\text{Re}(h_{ie})$	$V_{CE} = 10\text{V}, I_C = 5\text{mA}, f = 1\text{MHz}$	–	–	300	Ω

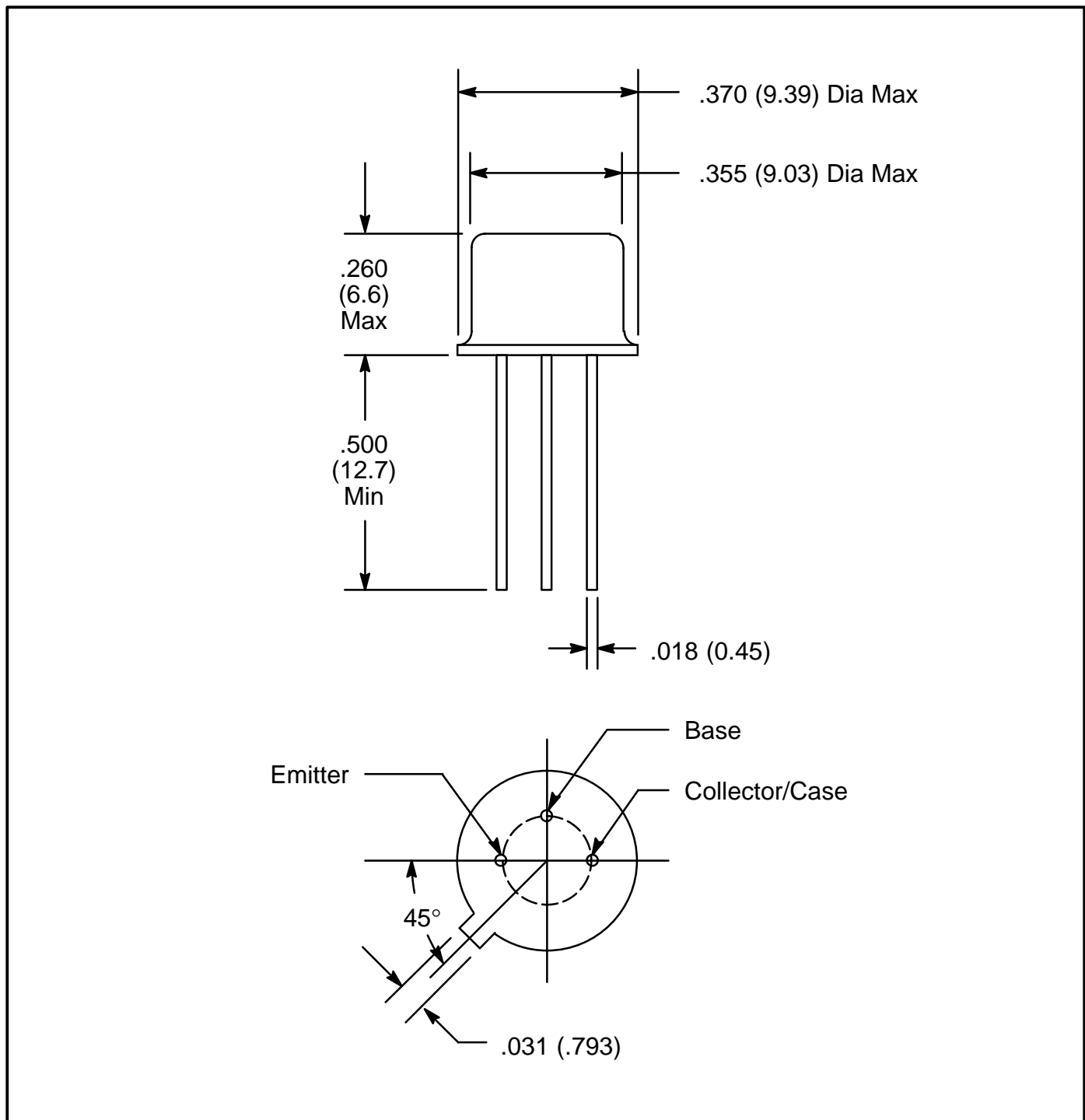

X-ON Electronics

Largest Supplier of Electrical and Electronic Components

Click to view similar products for [Bipolar Transistors - BJT category](#):

Click to view products by [NTE manufacturer](#):

Other Similar products are found below :

[619691C](#) [MCH4017-TL-H](#) [MJ15024/WS](#) [MJ15025/WS](#) [BC546/116](#) [BC556/FSC](#) [BC557/116](#) [BSW67A](#) [HN7G01FU-A\(T5L,F,T](#)
[NJVMJD148T4G](#) [NSVMMBT6520LT1G](#) [NTE187A](#) [NTE195A](#) [NTE2302](#) [NTE2330](#) [NTE2353](#) [NTE316](#) [IMX9T110](#) [NTE63](#) [NTE65](#)
[C4460](#) [SBC846BLT3G](#) [2SA1419T-TD-H](#) [2SA1721-O\(TE85L,F\)](#) [2SA1727TLP](#) [2SA2126-E](#) [2SB1202T-TL-E](#) [2SB1204S-TL-E](#) [2SC5488A-](#)
[TL-H](#) [2SD2150T100R](#) [SP000011176](#) [FMC5AT148](#) [2N2369ADCSM](#) [2SB1202S-TL-E](#) [2SC2412KT146S](#) [2SC4618TLN](#) [2SC5490A-TL-H](#)
[2SD1816S-TL-E](#) [2SD1816T-TL-E](#) [CMXT2207 TR](#) [CPH6501-TL-E](#) [MCH4021-TL-E](#) [BC557B](#) [TTC012\(Q\)](#) [BULD128DT4](#) [JANTX2N3810](#)
[Jantx2N5416](#) [US6T6TR](#) [KSF350](#) [068071B](#)