



317-897-7000
 sales@generaldevices.com
 www.generaldevices.com



PRODUCT CATALOG

Choose from the most complete selection of standard and custom slides, cabinets and racks available.

CHASSIS TRAK®
Telescopic Slides

VENT RAK®
Cabinets & Enclosures

CUSTOM METAL FABRICATION



MULTIPURPOSE SHELTERS



CABINETS AND RACKS



BOTTOM MOUNT SLIDES



BALL BEARING SLIDES



SOLID/ROLLER BEARING SLIDES

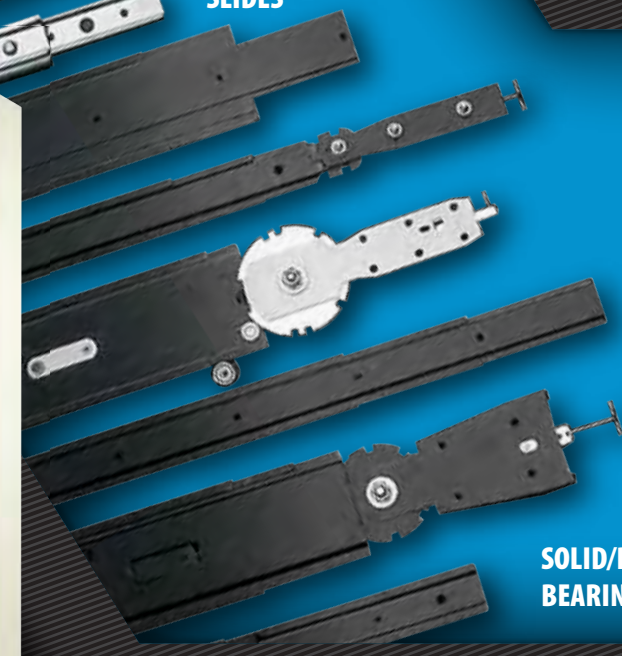

CABINET ACCESSORIES



General Devices Company
 P.O. Box 39100
 1410 S. Post Road
 Indianapolis, IN 46239-0100
 USA
Phone: 317-897-7000
Fax: 317-898-2917



Founded in 1953 by Herbert and Gladys Fall, General Devices Co., Inc. provides engineers and designers with quality products and unique solutions for electronic packaging requirements. While serving as a Naval officer, Herbert Fall recognized the need for easier and less time consuming ways to service the “hard” or “static” rack-mounted electronic equipment. He developed a new kind of telescoping slide - the original Chassis Trak[®] - which made equipment easier to install and service.

Today, we are the proud supplier of millions of slides and additional electronic packaging hardware to government agencies and private industries throughout the world.

General Devices has witnessed the progress that has taken place in electronics since 1953 and we have responded with packaging solutions and innovative hardware designs to meet each new technological advance. General Devices will continue this record of timely reply as the industry continues to advance.

The products of General Devices are at work today in diverse markets. From computers, communications, telecommunications, broadcasting and military, emergency and recreational vehicles, medical, mining and natural resources, General Devices serves customers worldwide.

Currently, General Devices offers telescoping chassis slides, chassis, commercial and military cabinets, cooling modules, cable carriers and other cabinet mounted hardware.

Additionally, with our own tool and die shop, we provide custom fabrication, stamping, welding, forming and finishing for our customers.

Still family owned, our products are sold through a network of factory representatives and distributors in the United States, Canada, Europe and through trading partners in the Middle East and Japan.

A close examination of our products will show our commitment to quality and design. Our service goes beyond manufacturing the best products, it includes a staff of engineers and knowledgeable applications specialists who are eager to help you meet your electronic hardware needs.

In October of 2004, General Devices received ISO 9001:2000 registration to further demonstrate our commitment to quality.

For your next project depend upon General Devices for innovative solutions and the best in electronic hardware.

Chassis Trak® Telescoping Slides



Solid Bearing Slides

C-230	Pg. 14
C-300	Pg. 16
CT/CTR	Pg. 18
CTH/CTHR	Pg. 22
Two Section Slides	Pg. 29
Optional Mounting Brackets	Pg. 34

Ball Bearing Slides

LBS-11	Pg. 37
LBS-12	Pg. 38
LBS-21	Pg. 39
LBS-22	Pg. 40
LBS-32	Pg. 41
LBS-O	Pg. 42
CLB-203	Pg. 43
CLB-223	Pg. 44
CLB-305	Pg. 45
CLB-307	Pg. 46
CLB-315	Pg. 47
Optional Mounting Brackets	Pg. 48

Bottom Mount Slides

B-200/B-300	Pg. 52
C-7000	Pg. 53
C-938	Pg. 54
D-1050/1054	Pg. 55





Vent Rak[®] **Cabinet Accessories**

Shelves	Pg. 57
Utility Chassis	Pg. 64
Cable Carriers	Pg. 71
Cooling Devices	Pg. 73

Cabinets and Racks

2500 Floor Mounted Relay Rack	Pg. 76
2600 Floor/Caster Mount Relay Rack	Pg. 77
6200 Medium Duty Cabinet	Pg. 78



Multipurpose Shelters



Custom Metal Fabrication

Six Reasons To Purchase General Devices Products

- **Experience** – General Devices has been the industry leader in the design and manufacture of packaging hardware for commercial and military applications for over 50 years. As technology has demanded change, General Devices has been the leader in providing solutions to unique application requirements of engineers.
- **Reliability** – You can rest assured that once you have purchased products from General Devices they will perform and meet all of your needs for years to come.
- **Fast Delivery** – Our extensive distributor network in the U.S. and Canada helps meet urgent requirements.
- **Low Costs** – Advanced production techniques enable General Devices to offer top quality products at some of the industry's most competitive prices.
- **Engineering Assistance** – General Devices' engineers are available to make recommendations for special slide applications. Even after delivery of your order, you can depend on our engineers to answer any of your questions.
- **Flexibility** – At your request, we will modify any of our existing products to suit your needs. And for those unique situations, our engineers will work with you to custom design a solution specifically for your application need.

Rapid Response

General Devices has based its business on the principles of Lean Manufacturing, allowing General Devices to react quickly to customer requirements. Extensive and modern manufacturing equipment, combined with the vertical integration of many manufacturing services such as: screw machining, die design and fabrication, assembly and plating, silk-screening, powder coat and wet painting assures General Devices of greater independence from third party suppliers.

Design Consultation

A staff of experienced application and design engineers is available to help select or develop the right packaging hardware to meet specific requirements. Unique computer aided design (CAD) capabilities also provide fast and economical design solutions to your problems.

Product Warranty

General Devices Company, Inc., will repair or replace products manufactured by General Devices that are proven to be defective in material or factory workmanship under normal use during the period of this warranty (one year from the date of purchase).

This Warranty Does Not Cover:

- Failure, in whole or in part, resulting from misuse, alteration, excessive temperature, excessive humidity, corrosive environment or lack of maintenance.
- Any materials or components used or manufactured pursuant to the purchaser's specification.
- Deterioration due to normal use and exposure.

Warranty Repair: Purchaser shall obtain written authorization before returning any items alleged to be defective to General Devices.

Inspection: General Devices shall have the right to inspect any and all allegedly defective items on-site at purchaser's convenience.

Disclaimer of Consequential Damages and Limitations of Implied Warranty: General Devices disclaims any responsibility for loss of time or use of parts or equipment wherein General Devices' products are used, transported or any other incidental or consequential damage; and implied Warranties, including the implied Warranty of merchantability and fitness for intended use, are limited to the duration of this written warranty.

General Provisions

General Devices' catalogs and any information and/or drawings supplied to outside parties, including, but not limited to, potential customers and purchasers, are the exclusive property of General Devices, and are to be used only for the purpose of providing information to potential customers and purchasers. These are not to be utilized for any other purpose and are not to be copied in whole or in part without the previously obtained written consent of General Devices.

To allow for continuous improvement of its product design, General Devices reserves the right to make design changes as it deems appropriate. Prior to General Devices sending out its order confirmations, General Devices' sales representatives and distributors shall deliver to potential purchasers written notification of any relevant major design changes in General Devices' products.

Quality Products

General Devices offers a full selection of electronic cabinets, enclosures and the related hardware used in electronic enclosures.

Chassis Trak® Telescoping Slides

General Devices manufactures the widest line of telescoping slides available to the electronics industry. In addition to bottom mount slides, hundreds of models of side-mounted solid bearing, roller bearing and ball bearing slides are available.

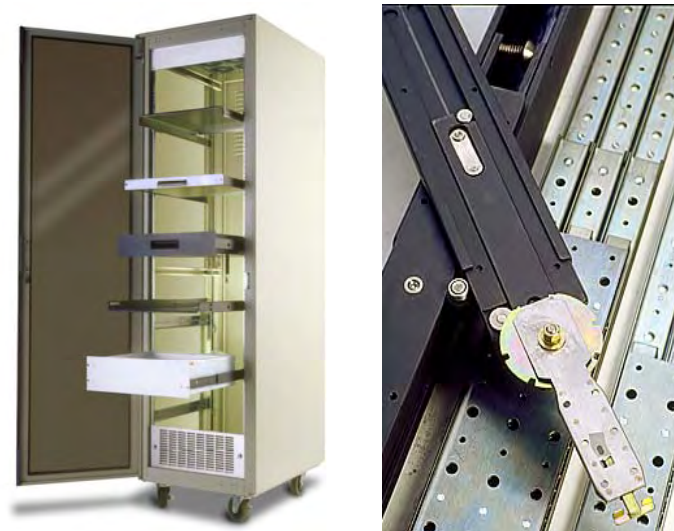

Vent Rak® Cabinets and Racks

A selection of commercial cabinets and racks are also manufactured by General Devices. You can select from simple relay racks to complete commercial systems.

Cable Carriers, Guides and Retractors

These guides and retractors keep cables neat and orderly to prevent sagging, pinching and abrasive wear. Units are shipped ready for installation on standard EIA/RETMA support rails.

Cooling Modules and Fan Trays

General Devices offers a full selection of cooling devices, including front panel modules and fan trays for horizontal rack mounting.

Shelves, Drawers, Writing Surfaces

Sliding shelves, fixed writing surfaces, storage drawers, or sliding platforms for equipment that cannot be rack-mounted - a comprehensive selection is available.

Assembly and Fabrication Services

Value added services include customer engineering, laser cutting of ferrous and non-ferrous metals, complete sheet metal fabrication, painting, plating, assembly and installation.

Six Features That Save You Time and Money

- **Quick Installation** — Our Chassis Trak[®] telescoping slides are designed for quick and easy installation. Easy-to-read instructions also accompany most slides shipped.
- **Complete Mounting Hardware** — All of the hardware needed to mount your slides to both the chassis and cabinet are available with your order. Optional mounting brackets are also available for specified applications. Our sales support staff will gladly assist you in ordering the proper hardware.
- **Lock-Out Feature** — A latch mechanism is available on most chassis sections to lock the slide in its extended position.
- **Quick Disconnect** — On all of the solid bearing slide models, the chassis may be completely removed from the cabinet by simply depressing the chassis section latch.
- **Smooth Slide Action** — Forming and machining slides to exact tolerances provides smooth sliding action with minimum deflection in the extended position.
- **Standardization** — All of General Devices' slides are designed to meet the universal RETMA (EIA) hole spacing standard.

Slide Considerations

There are several items to consider to ensure the successful installation of your slides.

- Is your unit cycled frequently?
- Does your unit require tilting to help with access?
- Will your cables or electrical wiring need a cable carrying device?
- If your unit malfunctions, is the ability to instantly remove and replace it important?
- How much accessibility will you need to the unit?

- Is access from the front and rear important?
- If solid mounting the chassis is needed, but access is desirable, is a movable cabinet applicable?
- Does your unit need frequent service or is frequent removal from the cabinet necessary?
- Will your equipment be subject to shock and vibration or rough handling?
- Is the space between the cabinet and chassis limited? Are bottom mounted slides needed?
- Is this a mobile installation with limited space (such as trucks, aircraft, ships, buses, etc.)?
- Does the weight of your unit require help (lift, jack, etc.) for removal/replacement?

Front Panel Clearance

An important design consideration is to allow clearance between the cabinet and the chassis front panel. This clearance, which depends on the panel height, slide clearance, and handles (or any other obstruction on the cabinet front) must be calculated for each specific application.

The Thickness of Chassis Trak[®] Slides

Chassis Trak[®] Solid Bearing Slides have a built in operational clearance which simplifies mounting and insures a smooth operation. This clearance is exemplified by the Min/Max figures in the table on page 9.

Because of the precise relationship of the balls with the raceways, Chassis Trak[®] Ball Bearing Slides do not have the operational clearance found in the solid bearing slides. While mounting is necessarily more precise, adjustment is easily accomplished by means of the adjustable mounting brackets.

All Chassis Trak[®] slides and mounts comply with the Universal RETMA (EIA) hole patterns.

Mounting of Slides When Depth Is A Problem

Mounting A Short Chassis; Rear Extension Support Bracket

When combining two different depths of chassis in one cabinet, it will be necessary to use a rear extension support bracket. This bracket will allow the rear of the slide to be secured to the rear mounting surface. See the mounting bracket pages 34 and 48.

Cabinet Depth

Cabinets normally are found in overall depths of 18 to 32 inches, in two-inch increments. The usable inside depth, which depends on the particular model of cabinet, determines the maximum depth chassis which could be mounted in a particular cabinet.

Slides are available in any length but are normally stocked in 10 through 24 inch lengths in two-inch increments. The vertical cabinet members to which slides mount are normally adjustable to match slide length. The use of additional cabinet vertical mounting members permits installation of a second-length slide. Consult factory for assistance.

Cabinet Width

Ideally the chassis width plus the thickness of the slides should equal the clear opening width of the cabinet, since the slide must pass between the chassis and the vertical members of the cabinet. The tables on page 9 describe standard chassis widths and the clear opening widths of cabinets.

Note: If chassis is too wide for side mounting slides, see CLB-305 on page 45 of this catalog. Also, a rack mount sliding shelf bottom mounted slide is available.

Mounting of Slides When Width Is A Problem

The following methods of mounting should be considered when width is a problem:

8

Too Little Space - Thin Slide

If width is critical in a particular application, consider using a thinner slide. The tables on page 9 describe the thickness of Chassis Trak[®] telescoping slides.

Recessed Mounting

The sliding thickness shown in the table on page 9 pertains to that part of the slide which must pass between the chassis and the edge of the cabinet opening when the stationary member is recessed behind the edge of the opening.

Bottom Mount

By mounting under the chassis, width no longer becomes a factor to consider in slides. See the Bottom Mount Slide section for details, page 51.

Too Much Space - Adjustable Support Brackets

Front support brackets are slotted to provide inward adjustment. Maximum adjustment is approximately 3/8 inch per side.

Strap Mounting

Most Solid Bearing slides can be manufactured with mounting straps in lieu of standard mounting flanges. Primary consideration must be given to the mating surface. Load tolerances of the mating surface, clearance for the back side locking mechanism and slide extension must all be evaluated. A backstop screw can be installed if no back stop is provided by the cabinet. See specific Solid Bearing slides for more information.

Special Application Slides

Custom and Modified General Devices Slides

Available from General Devices is the industry's widest selection of bottom mount, solid, ball and roller bearing slides. This combined product and application experience enable General Devices to design and manufacture custom slides or to modify standard models to meet your special requirements.

Solid Bearing Slides

General Devices' solid bearing slides provide high resistance to shock and vibration and are extremely well suited for mobile installations.

Ball Bearing Slides

General Devices' ball bearing slides are high precision slides that provide the smoothest operation for your most delicate instruments. Ball bearing slides are the choice for equipment and instrumentation that require frequent checking and where ease of operation is desired.

Detent Safety Recommendations

An unbalanced chassis load, either front or rear, may cause possible damage to the slide detent mechanism and cause injury to the operator activating the detent.

The unbalanced torque weight is released immediately by activating the detent and should never subject the operator to more than five pounds of unexpected torque weight. If it is impossible to meet this criteria, it is imperative to block or de-activate the detent, warn operator of the expected torque, and provide instructions on how to safely activate the detent.

If you have any questions or concerns, please contact the factory.

Cabinet Front Panel Width	Chassis Width	Cabinet Clear Opening Width			
		Minimum Standard	Most Cabinets		Vent Rak Cabinets
19	17	17.750	17.781	17.812	17.937
24	22	22.750	22.781	22.812	22.937
30	28	28.750	28.781	22.812	28.937
Maximum Allowable Slide Thickness		.375	.390	.406	.468

Solid Bearing Slides	Clearance Minimum	Required Maximum	Sliding Minimum	Thickness Maximum
C-230-S	.34	.41	.28	.32
C-230-D	.34	.41	.31	.34
C-300-S	.37	.49	.33	.37
C-300-D	.39	.52	.37	.41
CTS	.37	.46	.32	.37
CTD	.40	.49	.34	.38
CTRS	.37	.46	.32	.37
CTRD	.40	.49	.34	.38
CTHS	.42	.54	.35	.42
CTHD	.57	.67	.47	.55
CTHRS	.42	.54	.35	.42
CTHRD	.57	.67	.47	.55
C-649	.31	.37	.25	.27
C-857	.27	.32	.22	.24
C-874	.31	.37	.25	.27
C-917	.27	.32	.22	.24
C-3700	.24	.30	.18	.20

Ball Bearing Slides	Overall Thickness	Sliding Thickness
LBS-11	.38	.26
LBS-12	.76	.64
LBS-O	.50	.45
LBS-21	.50	.32
LBS-22	.94	.76
LBS-32	.94	.76
CLB-203	.38	.26
CLB-223	.50	.32
CLB-305	.76	.38
CLB-307	.76	.64
CLB-315	.50	.45

Bottom Mount Slides

General Devices' bottom mount slides are designed especially for light duty to heavy duty applications in the electronics, aerospace/airline, heavy equipment and machinery, trucking and transportation industries.

Big Loads, Little Effort

Chassis Trak[®] bottom mount slides let you make the most of valuable space by providing heavy load bearing capability and ease of extension for electronic racks and cabinets, telephone equipment, machine controls, generators, heavy transformers and other bulky or heavy equipment.

Bottom mount slides are available in models to handle capacities ranging from 75 lbs. to 1,500 lbs. Even greater loads are possible by combining several slides together so that they equally bear a portion of the load.

Chassis Trak[®] bottom mount slides are designed to handle compression loads with the slides mounted beneath the load. In addition, two models - the C-7000 and the B-200 - are suitable for suspension (tension load bearing) as well as compression load bearing applications. The C-7000 series is easily modified for two way travel - increasing the slide's versatility.

The "Spacemaker"

Chassis Trak[®] bottom mount slides can actually "make" space by the efficient utilization of corridors, limited access areas and nooks that might not otherwise be used. Aboard ships, on offshore oil rigs, in control rooms, in mobile broadcast vehicles - anywhere space is a premium, bottom mount slides can help store and provide access to equipment.

Bottom mount slides are also ideal where rail type movement is required; but where rails are impractical, or cannot be put into the floor.

Wide Applications

Following are just a few of the applications for Chassis Trak[®] bottom mount slides.

- Under electronic cabinets, telephone and PBX equipment
- Battery racks and charging units
- Power generators
- Air conditioner power units and cooling coils
- X-ray equipment in medical units
- Radio transmitters and antennas
- Equipment access in emergency aid vehicles
- Mobile broadcast platforms
- Support for seismic equipment in oil fields
- Clean room pass-through chambers with two-way slides

Extra Heavy Load Bearing Capability

Bottom mount slides are composed of heavy gauge sections of cold rolled steel coupled with solid, stainless steel rollers. Close tolerance rollers, stainless steel synchronizing retainers and precision balls minimize the pull force required for slide movement and provide vertical alignment of slide sections. The balls provide horizontal alignment.

When choosing bottom mount slides, weight is the first consideration. All Chassis Trak[®] bottom mount slides have a built-in 100% safety factor, and all can be applied safely at the rated capacity. Large or bulky loads may mean that several slides are required for balance or to compensate for load displacement.

Mounting Suggestions

Bottom mount slides should be mounted on a level surface that is free of obstruction when the slides are extended. When more than one bottom mount slide is used to carry the same load, slides should be mounted parallel to each other (+/- .031" recommended).

On C-938 units, the chassis member must be removed (remove the one screw) and mounted to drawer member with 82° F.H. screws. We recommend using a locking adhesive when re-installing the screw.

On D-1054 slides, the cabinet member must be mounted from beneath the unit. This is usually achieved by mounting slides to a bottom plate before installing them to a floor, etc.

General Devices can supply mounting plates or countersinking rear holes to enable slides to be mounted from the top whenever they are to be mounted in an application prohibiting the screws from being inserted from beneath the unit.

Do not exceed listed load capacities. Serious product damage or personal injury may occur. For increased load capacity, multiply the number of slides required for the application. General Devices will not be liable for product misuse, or the damages that may result from such misuse.

Custom Solutions

Standard bottom mount slides can meet the requirements of most applications. Some uses require unique solutions, and General Devices' slide engineering and design departments can help you find a fast and cost effective remedy to your design problem.

Our designers have developed special heavy duty slides with more than 60" of extension and a 1,000 pound load rating. Model C-7000 bottom mount slides have been modified to provide more than 85" of extension. Slides have been grouped to provide capacities of several tons.

General Devices' engineers have many years of experience applying telescoping slide technology to a variety of applications. From smooth, precision bottom mount slides used on a rotary optical examination module, to heavy duty slides used for service access to back-up power generators, General Devices can provide the right load bearing capacity and performance characteristics for nearly any requirement.



General Devices is capable of modifying or building custom slide products to meet unique requirements. Example above: Custom built bottom mount slides were utilized by Bombardier to provide access to battery trays on one of their electric locomotives.

Pictured below are some custom bottom mount slides holding an air conditioner used to cool the crew compartment on a traditional style train.



Vent Rak[®] Cabinets

Extensive and modern manufacturing plants provide General Devices with sole supplier capabilities - from tool and die design and screw machining, to fabrication, laser cutting and finishing. This enables us to control the quality of your finished product and assures independence from suppliers.

Standard Options

Buss Bars

Available for factory installation, buss bars provide not only common ground but also low impedance connections between removable plug-in circuit modules, the host circuit ground plane and power buses.

Multi-Outlet Power Strips

Multi-outlet power strips allow easy access of power to the electronics mounted inside the cabinet. These power strips have grounded receptacles rated 15 Amp., 125V, pre-wired with Number 12 type TW conductors. Receptacles are located at 6" apart.

Plexiglas[®] Door

As an option, a Plexiglas[®] door may be provided to protect delicate instruments and permit easy viewing. Smoke (#2094 Gray) or clear is available.

Writing Top

When a writing or counter surface is desired in front of the cabinet, the bolt-on writing surface provides a 1.25" thick plastic laminate writing surface. It bolts to a channel bracket, and the total assembly is mounted to the front of the cabinet. The total vertical space requirement for the writing surface is 5.25"

Casters

Various caster assembly/caster options are available. All casters should be selected to meet requirements of fully loaded cabinets.

Eyebolts

Eyebolts, or "lifting eyes" may be provided in each corner at the top of cabinets. For light and medium loads, the standard eyebolt option is rated at 1400 lb. capacity with a 1" diameter eyelet and a 3/8-16 threaded stem. For heavy loads (2600 lb. capacity), a 1.25" diameter eyelet and 1/2-13 threaded stem is recommended.

Modification of Standard Product

Based on the customers requirement, standard components can be modified easily to satisfy unique applications. Some of the routine modifications supplied include:

- Custom vertical panel openings, panel widths or cabinet depths
- Customer specified access and control cutouts
- Structural reinforcement
- Special airflow provisions

Cabinet Accessories

General Devices offers a full selection of electronic cabinets and enclosure related hardware.

Cable Carriers, Guides and Retractors

These guides and retractors keep cables neat and orderly to prevent sagging, pinching and abrasive wear. Units are shipped ready for installation on standard EIA/RETMA support rails.

Cooling Modules and Fan Trays

General Devices offers a full selection of cooling devices, including front panel modules and fan trays for horizontal rack mounting.

Shelves, Drawers, Writing Surfaces

Sliding shelves, fixed writing surfaces, storage drawers, or sliding platforms for equipment that cannot be rack-mounted - a comprehensive selection is available.



C-230

These fully extendable, three-section slides are designed to fit any standard rack or enclosure. The solid bearing surfaces provide high resistance to shock and vibration and make these utility slides extremely well suited to mobile installations. Stop latches permit instantaneous removal of the chassis. All models are available with optional strap mounting.



C-300

The C-300 economical, compact solid bearing slide is ideally suited to commercial applications in addition to being approved for military applications. Rigid quality controls during manufacture assure you of smooth sliding action and a minimum of deflection or play when the slides are in the extended position.

NOTE: In a standard C-300 set, two right-hand slides are provided.



CT/CTR

The CT slides are fully extendable, three-section basic slides designed to fit any standard rack or enclosure. Standard features include automatic lock-out and pushbutton lock release that permits instant chassis removal from the rack. Pencil thin design permits installation of standard 17" chassis in a standard 19" rack.

NOTE: CTH/CTHR (Heavy Duty models are also available)



Two Section

Two section slides are thinner but just as sturdy as standard units. These thin slides allow for a wider chassis application. Two Section slides are supplied as flat mount or with a return flange to meet standard mounting requirements.

The Two Section Series slides are an electronic equipment "spacesaver" in that they allow a wide chassis to fit into cabinets that were previously too small.

C-230-D Pivot Slide

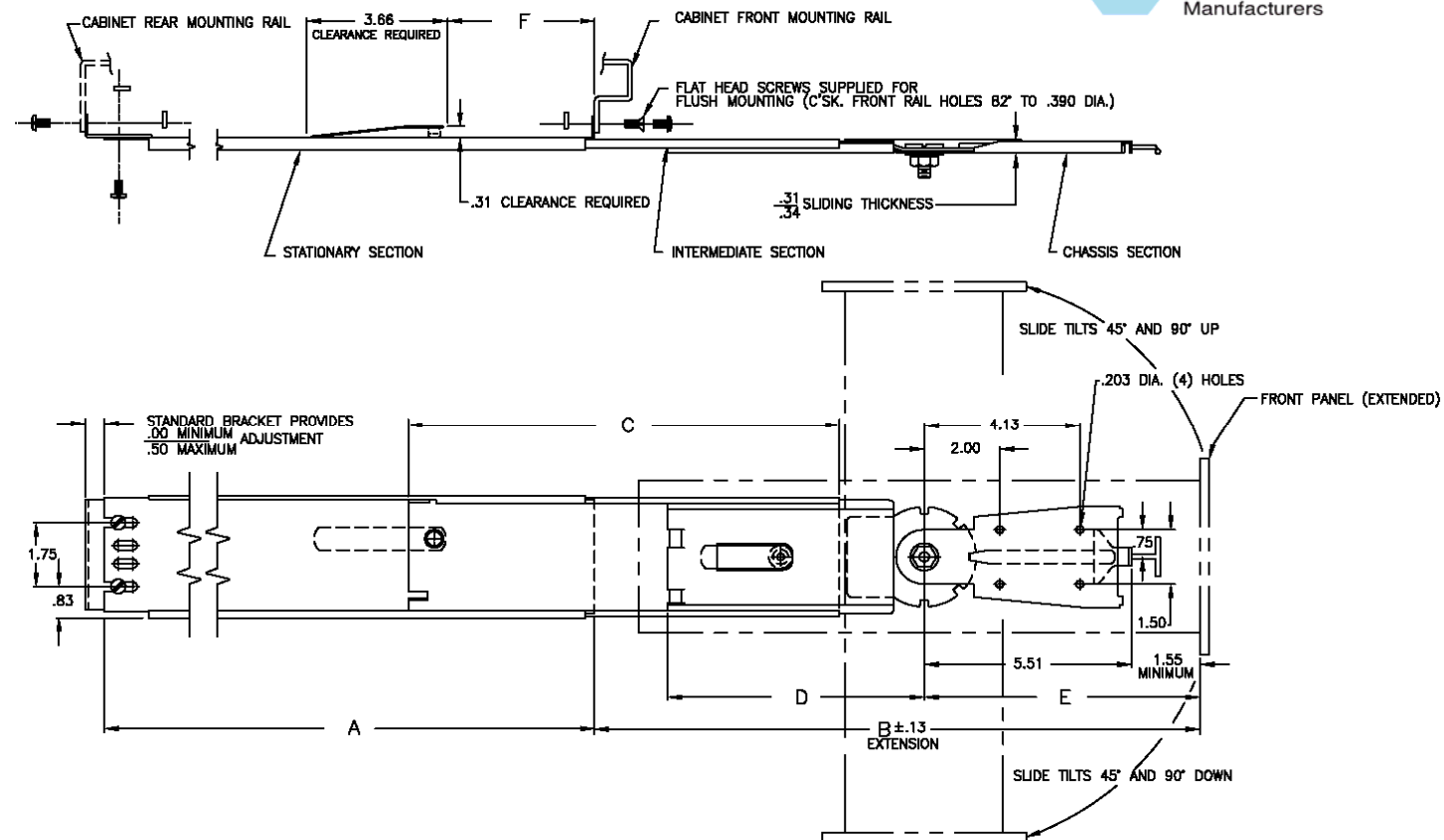

Catalog Number	A	B (min)	B (max)	C	D	E (min)	E (max)	F	Load Capacity
C-230-D-112	12.00	15.00	15.00	11.00	4.81	5.69	5.69	1.81	140 LBS.
C-230-D-114	14.00	18.00	18.00	13.00	6.81	5.69	5.69	1.81	140 LBS.
C-230-D-116	16.00	16.00	18.00	13.00	6.81	5.69	7.69	3.81	135 LBS.
C-230-D-118	18.00	22.00	22.00	17.00	8.81	7.69	7.69	3.81	135 LBS.
C-230-D-120	20.00	20.00	22.00	17.00	8.81	7.69	9.69	5.81	130 LBS.
C-230-D-122	22.00	26.00	26.00	21.00	10.81	9.69	9.69	5.81	130 LBS.
C-230-D-124	24.00	24.00	26.00	21.00	10.81	9.69	11.69	7.81	125 LBS.

TO ORDER, SPECIFY

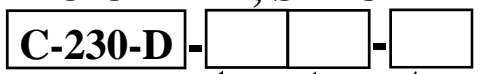

Stationary Section
 1 - Cabinet Mount
 2 - Strap Mount
 4 - Closed Slot
 For information on Strap Mount option see page 27.

Notes

- Right hand and left hand slides are identical. Set contains 2 right hand slides.
- Finish: All standard slides are coated with Poxylube™ dry film lubricant.
- All standard slides are designed to lock-out in the extended position and are available with an optional automatic release if lock-out is not desirable.
- Standard hardware packages include all the hardware necessary to mount your Chassis Trak® slides:
 - Rear mounting bracket (B-131) included
 - Bar Nuts (CA8056-06-0020)
 - #10-32 screws and keps nuts
- All sliding members of the standard slide are made from cold rolled steel.
- All Chassis Trak® solid bearing slides are supplied with a quick disconnect feature.
- Optional mounting patterns, slide lengths and extensions are available.
- See safety recommendations for detent slides on page 9.
- For optional mounting brackets see page 35.

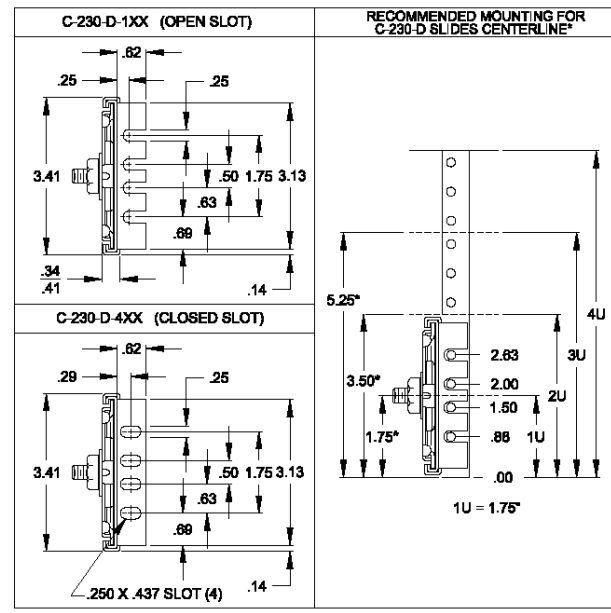

C-230-S Slide

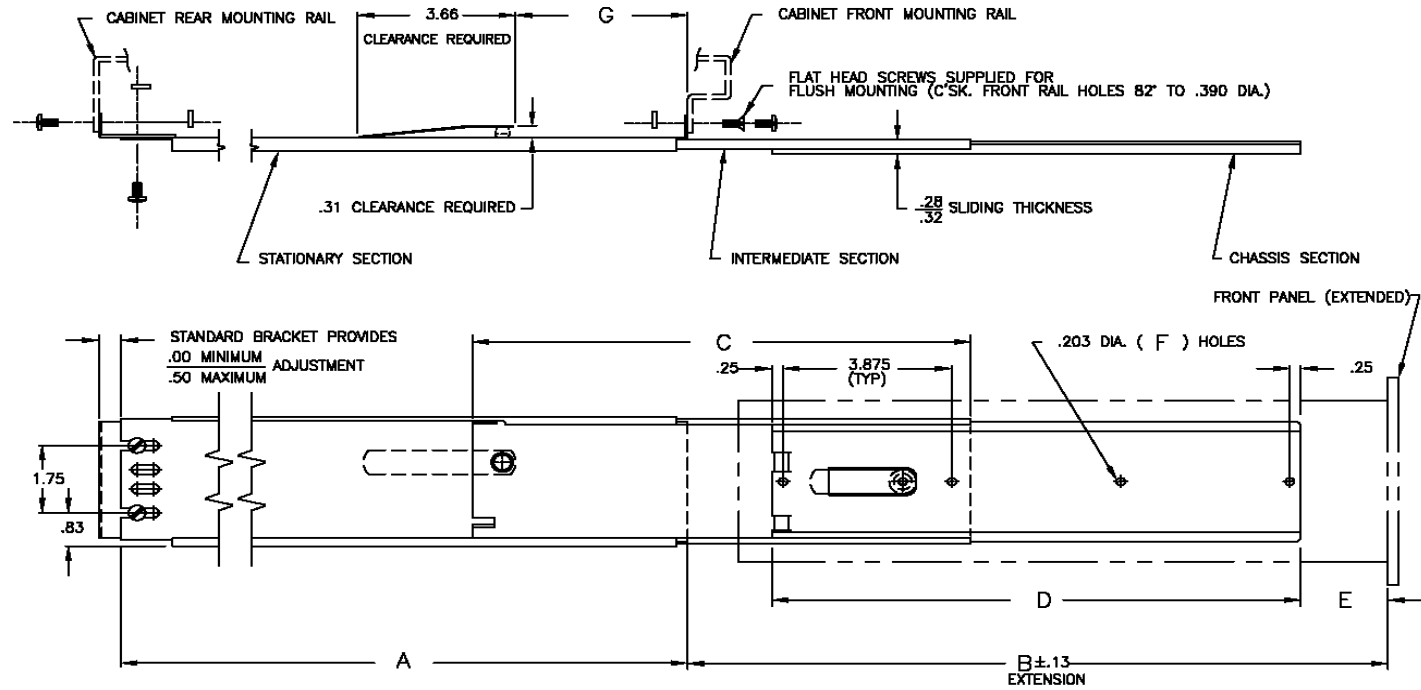

Catalog Number	A	B (min)	B (max)	C	D	E (min)	E (max)	F	G	Load Capacity
C-230-S-112	12.00	15.00	15.00	11.00	8.25	2.25	2.25	3	1.81	140 LBS.
C-230-S-114	14.00	18.00	18.00	13.00	12.13	0.38	0.38	4	1.81	140 LBS.
C-230-S-116	16.00	16.00	18.00	13.00	12.13	0.38	2.38	4	3.81	135 LBS.
C-230-S-118	18.00	22.00	22.00	17.00	12.13	4.38	4.38	4	3.81	135 LBS.
C-230-S-120	20.00	20.00	22.00	17.00	16.00	0.50	2.50	5	5.81	130 LBS.
C-230-S-122	22.00	26.00	26.00	21.00	16.00	4.50	4.50	5	5.81	130 LBS.
C-230-S-124	24.00	24.00	26.00	21.00	16.00	4.50	6.50	5	7.81	125 LBS.

TO ORDER, SPECIFY



Stationary Section
 1 - Cabinet Mount
 2 - Strap Mount
 4 - Closed Slot
 For information on Strap Mount option see page 27.

Notes

- Right hand and left hand slides are identical. Set contains 2 right hand slides.
- Finish: All standard slides are coated with Poxylube™ dry film lubricant.
- All standard slides are designed to lock-out in the extended position and are available with an optional automatic release if lock-out is not desirable.
- Standard hardware packages include all the hardware necessary to mount your Chassis Trak® slides:
 - Rear mounting bracket (B-131) included
 - Bar Nuts (CA8056-06-0020)
 - #10-32 screws and keps nuts
- All sliding members of the standard slide are made from cold rolled steel.
- All Chassis Trak® solid bearing slides are supplied with a quick disconnect feature.
- Optional mounting patterns, slide lengths and extensions are available.
- For optional mounting brackets see page 35.

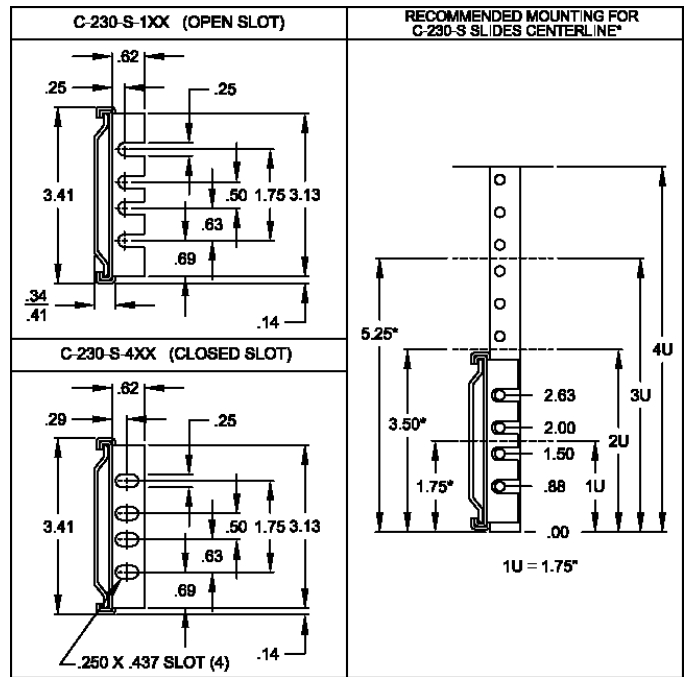

C-300-D Pivot Slide

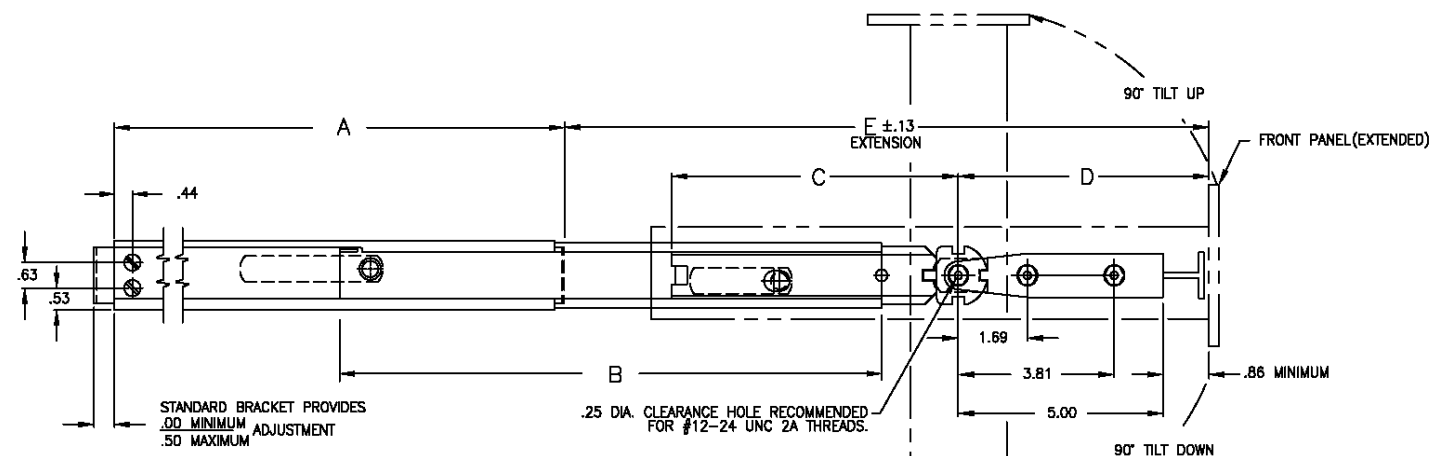
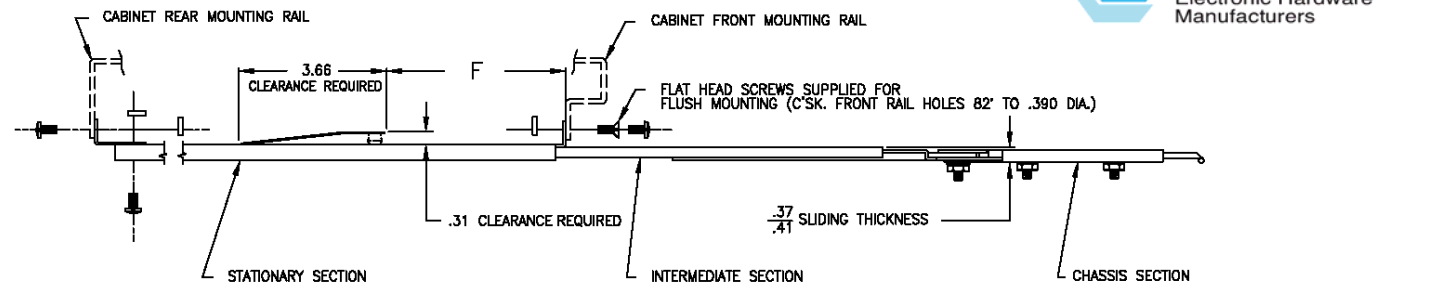

Catalog Number	A	B	C	D (min)	D (max)	E (min)	E (max)	F	Load Capacity
C-300-D-112	12.00	9.25	5.00	5.86	5.86	13.61	13.61	2.31	95 LBS.
C-300-D-114	14.00	13.25	7.00	5.86	5.86	15.61	15.61	4.31	90 LBS.
C-300-D-116	16.00	13.25	7.00	5.86	7.80	15.61	17.55	4.31	90 LBS.
C-300-D-118	18.00	13.25	7.00	5.86	9.80	15.61	19.55	4.31	90 LBS.
C-300-D-120	20.00	19.25	13.00	5.86	5.86	21.61	21.61	7.31	85 LBS.
C-300-D-122	22.00	19.25	13.00	5.86	7.80	21.61	23.55	7.31	85 LBS.
C-300-D-124	24.00	19.25	13.00	5.86	9.80	21.61	25.55	7.31	85 LBS.
C-300-D-126	26.00	25.25	19.00	5.86	5.86	27.61	27.61	10.31	80 LBS.
C-300-D-128	28.00	25.25	19.00	5.86	7.80	27.61	29.55	10.31	80 LBS.
C-300-D-130	30.00	25.25	19.00	5.86	9.80	27.61	31.55	10.31	80 LBS.

TO ORDER, SPECIFY

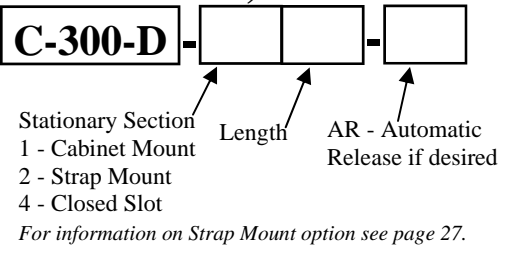

Notes

1. Finish: All standard slides are coated with Poxylube™ dry film lubricant.
2. All standard slides are designed to lock-out in the extended position and are available with an optional automatic release if lock-out is not desirable.
3. Standard hardware packages include all the hardware necessary to mount your Chassis Trak® slides:
 - Rear mounting bracket (B-217 or B-161) included
 - Bar Nuts (CA8056-06-0017 or CA8056-06-0014)
 - #10-32 screws and keps nuts
4. All sliding members of the standard slide are made from cold rolled steel.
5. All Chassis Trak® solid bearing slides are supplied with a quick disconnect feature.
6. Optional mounting patterns, slide lengths and extensions are available.
7. See safety recommendations for detent slides on page 9.
8. For optional mounting brackets see page 34.

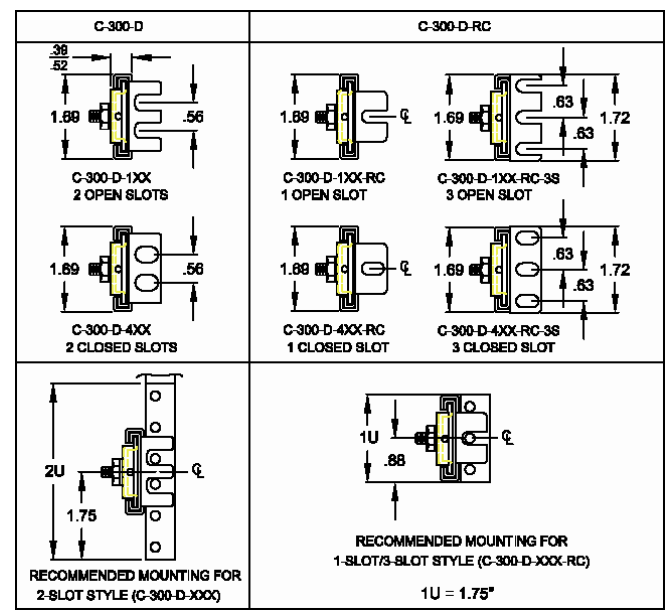

C-300-S Slide

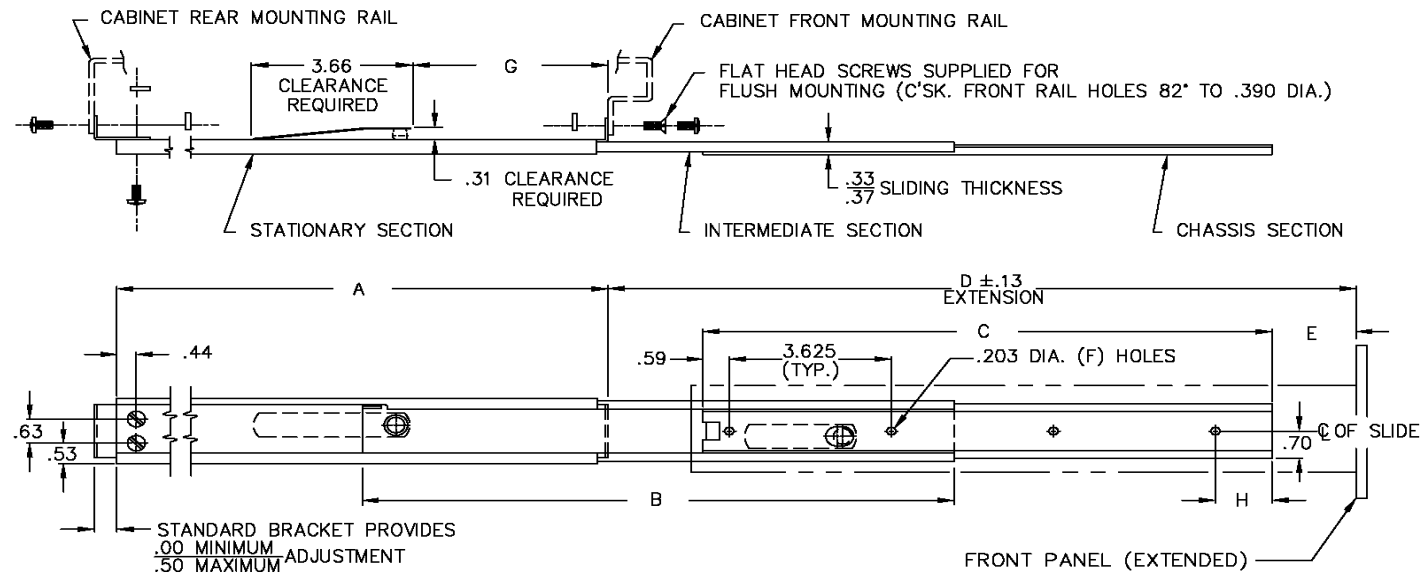

Catalog Number	A	B	C	D (min)	D (max)	E (min)	E (max)	F	G	H	Load Capacity
C-300-S-110	10.00	9.25	8.63	11.00	11.00	0.13	0.13	3	2.31	0.78	95 LBS.
C-300-S-112	12.00	9.25	8.63	11.00	13.00	0.13	2.13	3	2.31	0.78	95 LBS.
C-300-S-114	14.00	13.25	12.63	15.00	15.00	0.13	0.13	4	4.31	1.16	90 LBS.
C-300-S-116	16.00	13.25	12.63	15.00	17.00	0.13	2.13	4	4.31	1.16	90 LBS.
C-300-S-118	18.00	13.25	12.63	15.00	19.00	0.13	4.13	4	4.31	1.16	90 LBS.
C-300-S-120	20.00	19.25	18.63	21.00	21.00	0.13	0.13	5	7.31	3.53	85 LBS.
C-300-S-122	22.00	19.25	18.63	21.00	23.00	0.13	2.13	5	7.31	3.53	85 LBS.
C-300-S-124	24.00	19.25	18.63	21.00	25.00	0.13	4.13	5	7.31	3.53	85 LBS.
C-300-S-126	26.00	25.25	24.63	27.00	27.00	0.13	0.13	7	10.31	2.28	80 LBS.
C-300-S-128	28.00	25.25	24.63	27.00	29.00	0.13	2.13	7	10.31	2.28	80 LBS.
C-300-S-130	30.00	25.25	24.63	27.00	31.00	0.13	4.13	7	10.31	2.28	80 LBS.

TO ORDER, SPECIFY



Stationary Section
 1 - Cabinet Mount
 2 - Strap Mount
 4 - Closed Slot

Length

AR - Automatic Release if desired
 AND/OR
 RC - See chart below

For information on Strap Mount option see page 27.

Notes

- Finish: All standard slides are coated with Poxylube™ dry film lubricant.
- All standard slides are designed to lock-out in the extended position and are available with an optional automatic release if lock-out is not desirable.
- Standard hardware packages include all the hardware necessary to mount your Chassis Trak® slides:
 - Rear mounting bracket (B-217 or B-161) included
 - Bar Nuts (CA8056-06-0017 or CA8056-06-0014)
 - #10-32 screws and keps nuts
- All sliding members of the standard slide are made from cold rolled steel.
- All Chassis Trak® solid bearing slides are supplied with a quick disconnect feature.
- Optional mounting patterns, slide lengths and extensions are available.
- For optional mounting brackets see page 34.

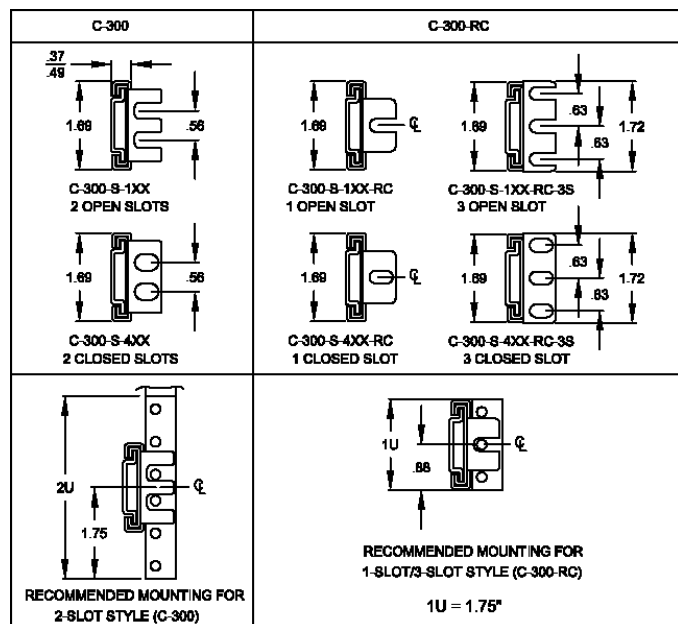

CTD Pivot Slide

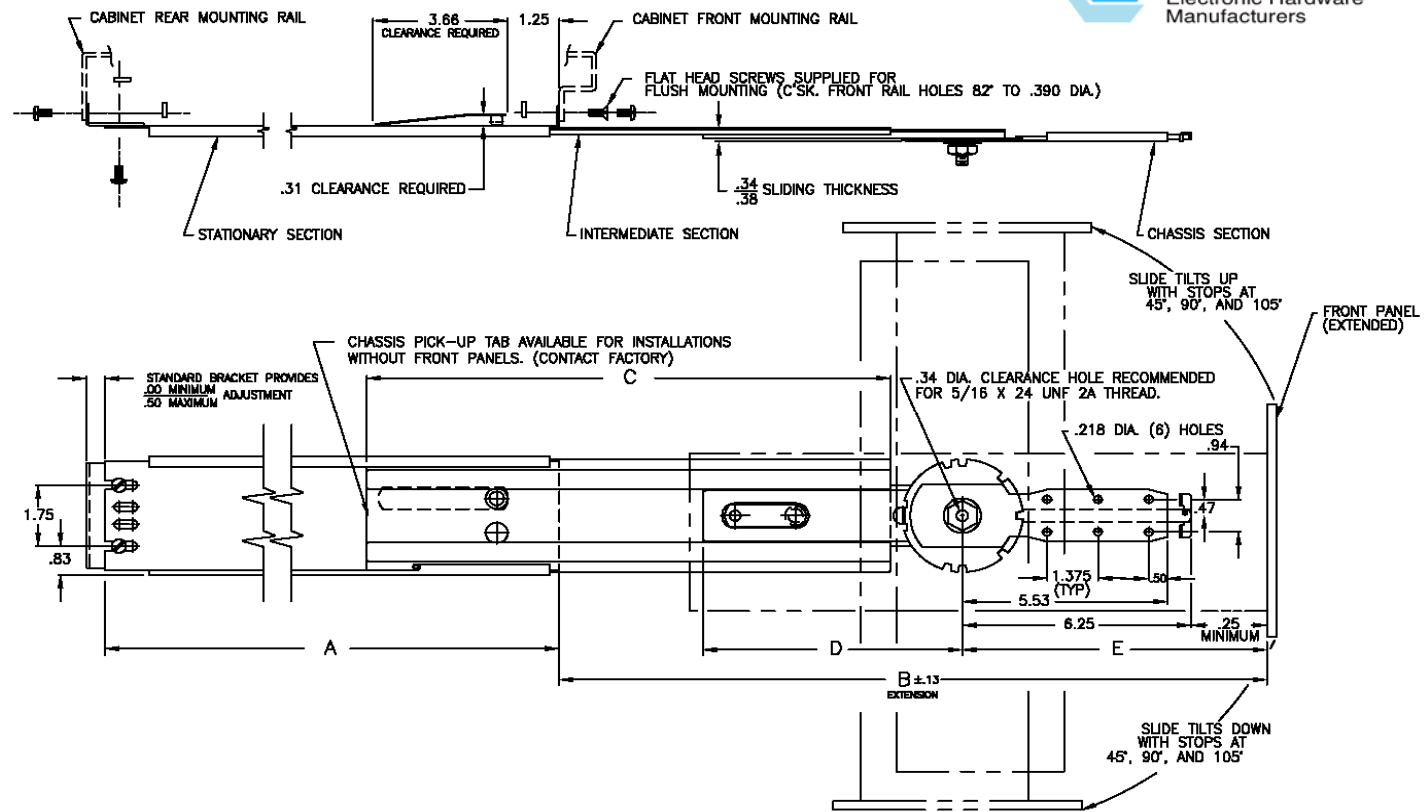

Catalog Number	A	B (min)	B (max)	C	D	E (min)	E (max)	Load Capacity
CTD-112	12.00	14.56	14.56	11.00	5.50	6.50	6.50	175 LBS.
CTD-114	14.00	16.25	16.75	13.00	7.00	6.50	7.00	175 LBS.
CTD-116	16.00	19.00	19.63	15.00	8.88	6.50	7.13	175 LBS.
CTD-118	18.00	21.00	23.63	17.00	8.88	6.50	9.13	175 LBS.
CTD-120	20.00	23.00	27.63	19.00	8.88	6.50	11.13	175 LBS.
CTD-122	22.00	26.25	31.63	21.00	9.75	6.88	12.25	175 LBS.
CTD-124	24.00	28.25	34.63	23.00	9.75	7.88	14.25	175 LBS.

TO ORDER, SPECIFY

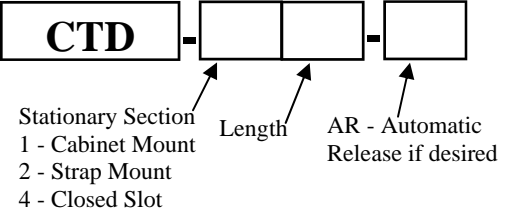

For information on mounting slides to Off-Set mounting rail see page 26.
For information on Strap Mount option see page 27.

Notes

- Right hand shown, left hand opposite.
- Finish: All standard slides are coated with Poxylube™ dry film lubricant.
- All standard slides are designed to lock-out in the extended position and are available with an optional automatic release if lock-out is not desirable.
- Standard hardware packages include all the hardware necessary to mount your Chassis Trak® slides:
 - Rear mounting bracket (B-131) included
 - Bar Nuts (CA8056-06-0020)
 - #10-32 screws and keps nuts
- All sliding members of the standard slide are made from cold rolled steel.
- All Chassis Trak® solid bearing slides are supplied with a quick disconnect feature.
- Optional mounting patterns, slide lengths and extensions are available.
- Pickup tab available for units without a front panel.
- See safety recommendations for detent slides on page 9.
- For optional mounting brackets see pages 35.

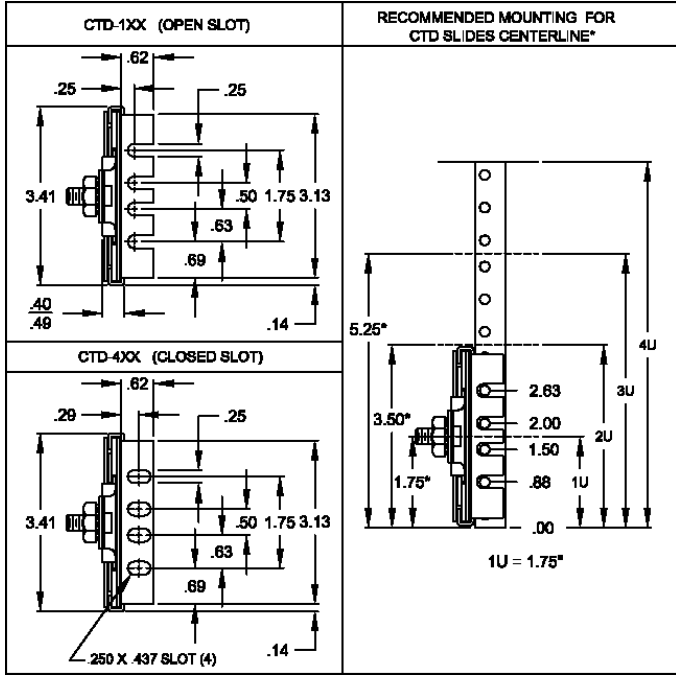

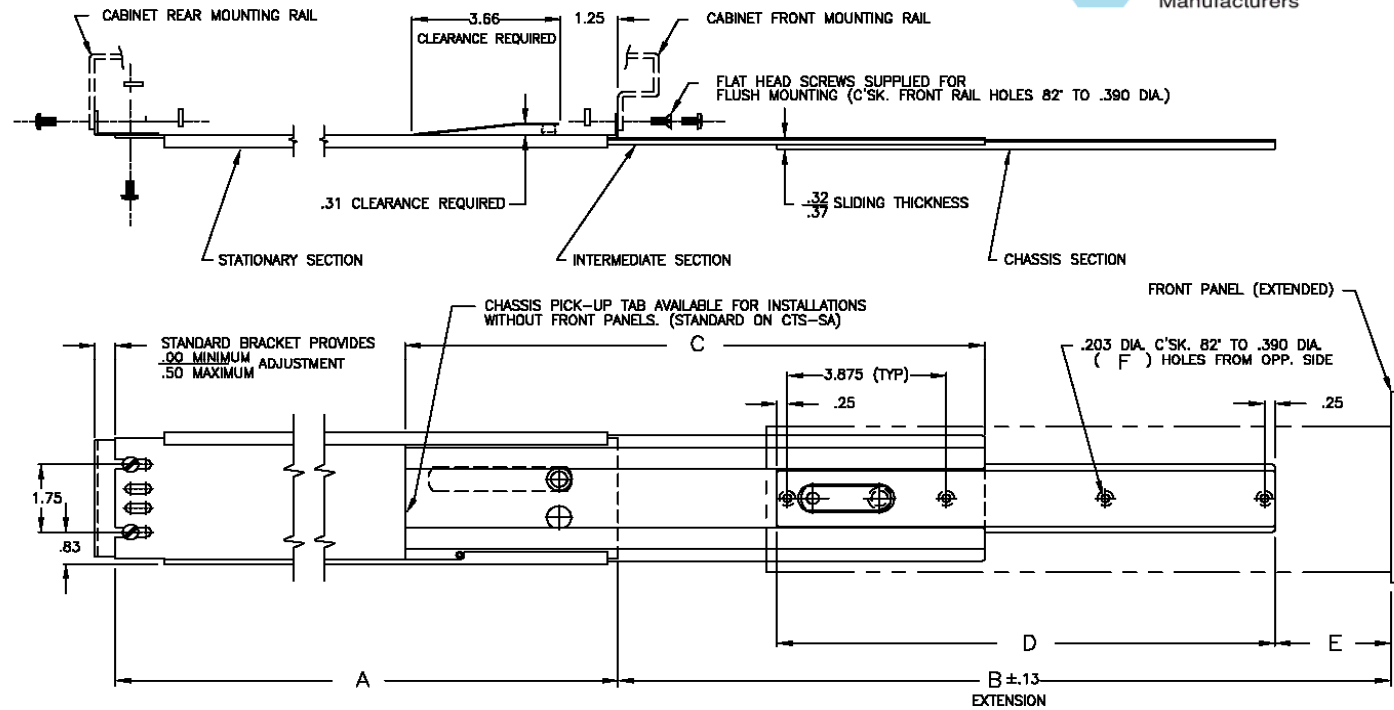

Catalog Number	A	B (min)	B (max)	C	D	E (min)	E (max)	F	Load Capacity
CTS-110	10.00	9.44	11.19	9.00	8.25	0.00	1.75	3	175 LBS.
CTS-112	12.00	10.81	14.56	11.00	8.25	0.00	3.75	3	175 LBS.
CTS-114	14.00	14.88	16.75	13.00	12.13	0.00	1.88	4	175 LBS.
CTS-116	16.00	15.75	19.63	15.00	12.13	0.00	3.88	4	175 LBS.
CTS-118	18.00	21.63	23.63	17.00	16.00	0.00	2.00	5	175 LBS.
CTS-120	20.00	23.63	27.63	19.00	16.00	0.00	4.00	5	175 LBS.
CTS-122	22.00	26.25	31.63	21.00	16.00	0.63	6.00	5	175 LBS.
CTS-124	24.00	28.25	34.63	23.00	16.00	1.63	8.00	5	175 LBS.

TO ORDER, SPECIFY

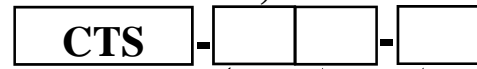

- Stationary Section
- 1 - Cabinet Mount
- 2 - Strap Mount
- 4 - Closed Slot
- AR - Automatic Release if desired

For information on mounting slides to Off-Set mounting rail see page 26.

For information on Strap Mount option see page 27.

Notes

- Right hand shown, left hand opposite.
- Finish: All standard slides are coated with Poxylube™ dry film lubricant.
- All standard slides are designed to lock-out in the extended position and are available with an optional automatic release if lock-out is not desirable.
- Standard hardware packages include all the hardware necessary to mount your Chassis Trak® slides:
 - Rear mounting bracket (B-131) included
 - Bar Nuts (CA8056-06-0020)
 - #10-32 screws and keps nuts
- All sliding members of the standard slide are made from cold rolled steel.
- All Chassis Trak® solid bearing slides are supplied with a quick disconnect feature.
- Optional mounting patterns, slide lengths and extensions are available.
- Pickup tab available for units without a front panel.
- For optional mounting brackets see page 35.

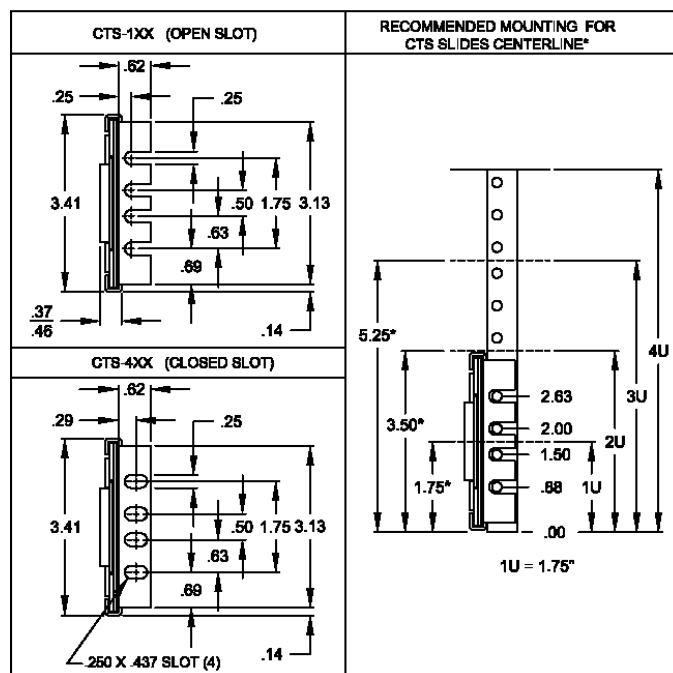

CTRD Pivot Slide

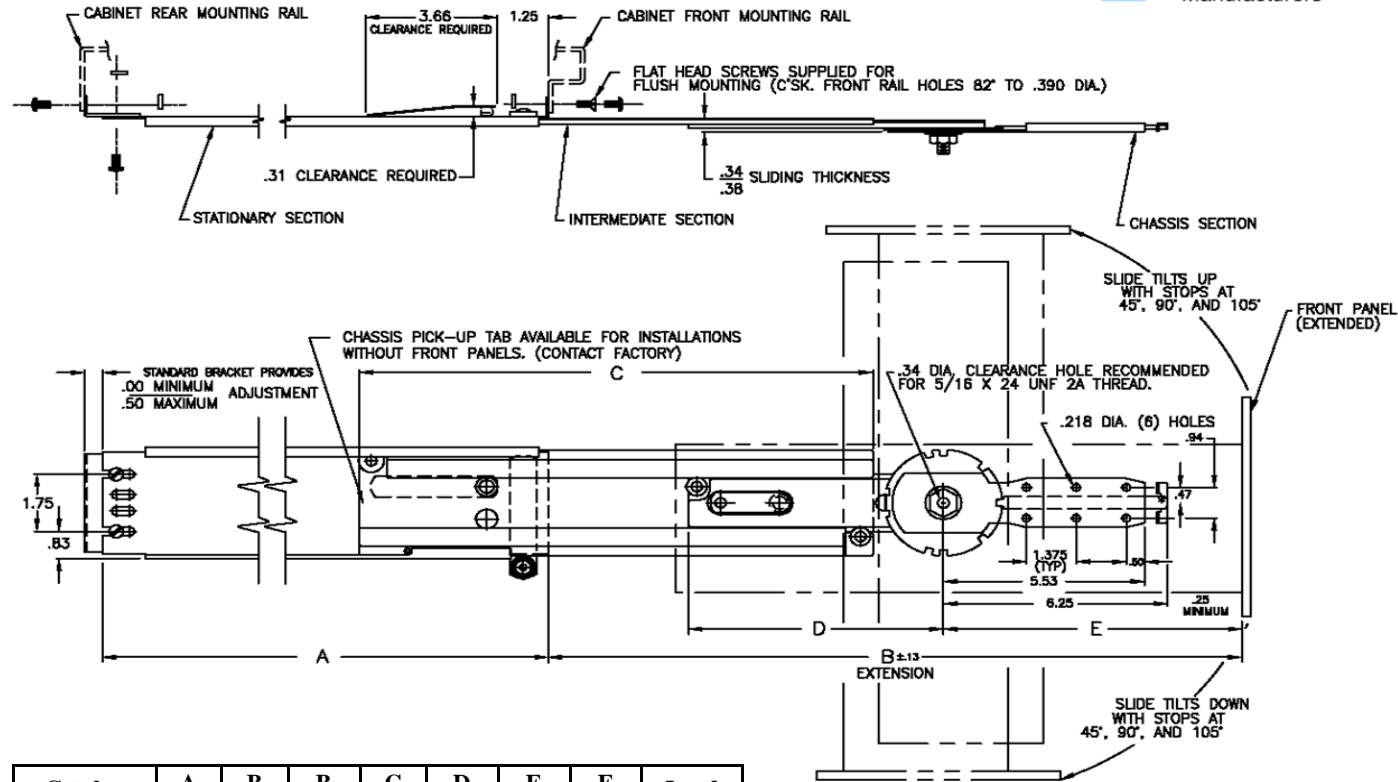

Catalog Number	A	B (min)	B (max)	C	D	E (min)	E (max)	Load Capacity
CTRD-112	12.00	14.56	14.56	11.00	5.50	6.50	6.50	175 LBS.
CTRD-114	14.00	16.25	16.75	13.00	7.00	6.50	7.00	175 LBS.
CTRD-116	16.00	19.00	19.63	15.00	8.88	6.50	7.13	175 LBS.
CTRD-118	18.00	21.00	23.63	17.00	8.88	6.50	9.13	175 LBS.
CTRD-120	20.00	23.00	27.63	19.00	8.88	6.50	11.13	175 LBS.
CTRD-122	22.00	26.25	31.63	21.00	9.75	6.88	12.25	175 LBS.
CTRD-124	24.00	28.25	34.63	23.00	9.75	7.88	14.25	175 LBS.

TO ORDER, SPECIFY

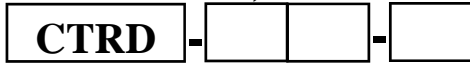

Stationary Section
 1 - Cabinet Mount
 2 - Strap Mount
 4 - Closed Slot

Length

AR - Automatic Release if desired

For information on mounting slides to Off-Set mounting rail see page 26.
 For information on Strap Mount option see page 28.

Notes

- Right hand shown, left hand opposite.
- Finish: All standard slides are coated with Poxylube™ dry film lubricant.
- All standard slides are designed to lock-out in the extended position and are available with an optional automatic release if lock-out is not desirable.
- Standard hardware packages include all the hardware necessary to mount your Chassis Trak® slides:
 - Rear mounting bracket (B-131) included
 - Bar Nuts (CA8056-06-0020)
 - #10-32 screws and keps nuts
- All sliding members of the standard slide are made from cold rolled steel.
- All Chassis Trak® solid bearing slides are supplied with a quick disconnect feature.
- Optional mounting patterns, slide lengths and extensions are available.
- Pickup tab available for units without a front panel.
- See safety recommendations for detent slides on page 9.
- For optional mounting brackets see pages 35.

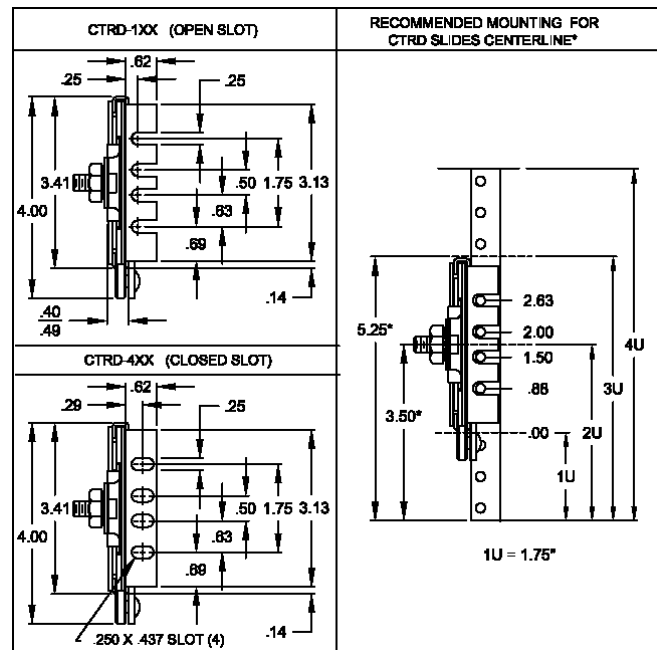

CTRS Slide

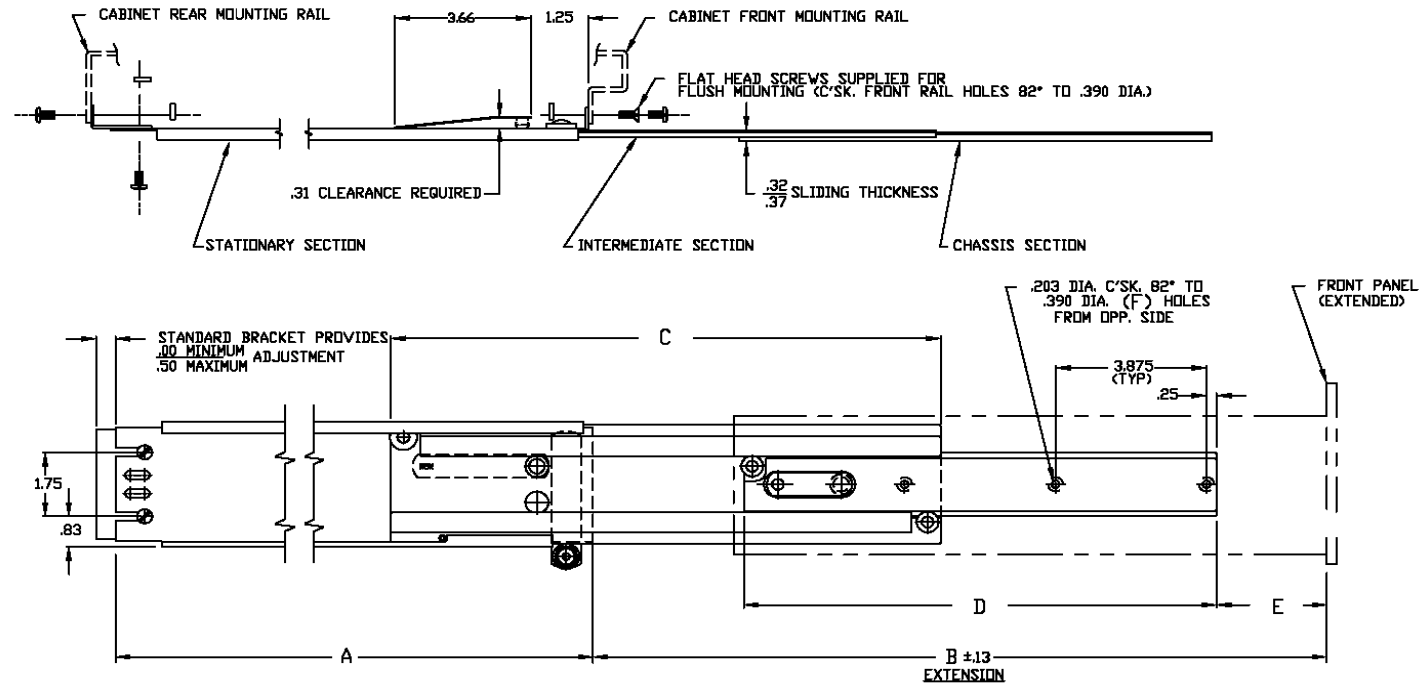

Catalog Number	A	B (min)	B (max)	C	D	E (min)	E (max)	F	Load Capacity
CTRS-110	10.00	9.44	11.19	9.00	8.25	0.00	1.75	2	175 LBS.
CTRS-112	12.00	10.81	14.56	11.00	8.25	0.00	3.75	2	175 LBS.
CTRS-114	14.00	14.88	16.75	13.00	12.13	0.00	1.88	2	175 LBS.
CTRS-116	16.00	15.75	19.63	15.00	12.13	0.00	3.88	3	175 LBS.
CTRS-118	18.00	21.63	23.63	17.00	16.00	0.00	2.00	4	175 LBS.
CTRS-120	20.00	23.63	27.63	19.00	16.00	0.00	4.00	4	175 LBS.
CTRS-122	22.00	26.24	31.63	21.00	16.00	0.63	6.00	4	175 LBS.
CTRS-124	24.00	28.24	34.63	23.00	16.00	1.63	8.00	4	175 LBS.

TO ORDER, SPECIFY



- Stationary Section
- 1 - Cabinet Mount
- 2 - Strap Mount
- 4 - Closed Slot
- Length
- AR - Automatic Release if desired

For information on mounting slides to Off-Set mounting rail see page 26.
 For information on Strap Mount option see page 28.

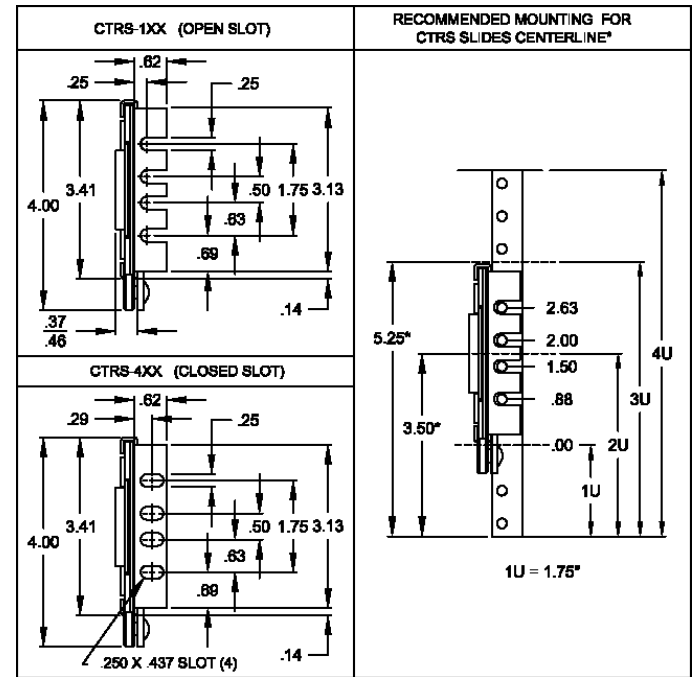

Notes

1. Right hand shown, left hand opposite.
2. Finish: All standard slides are coated with Poxylube™ dry film lubricant.
3. All standard slides are designed to lock-out in the extended position and are available with an optional automatic release if lock-out is not desirable.
4. Standard hardware packages include all the hardware necessary to mount your Chassis Trak® slides:
 - Rear mounting bracket (B-131) included
 - Bar Nuts (CA8056-06-0020)
 - #10-32 screws and keps nuts
5. All sliding members of the standard slide are made from cold rolled steel.
6. All Chassis Trak® solid bearing slides are supplied with a quick disconnect feature.
7. Optional mounting patterns, slide lengths and extensions are available.
8. Pickup tab available for units without a front panel.
9. For optional mounting brackets see page 35.

CTHD Pivot Slide

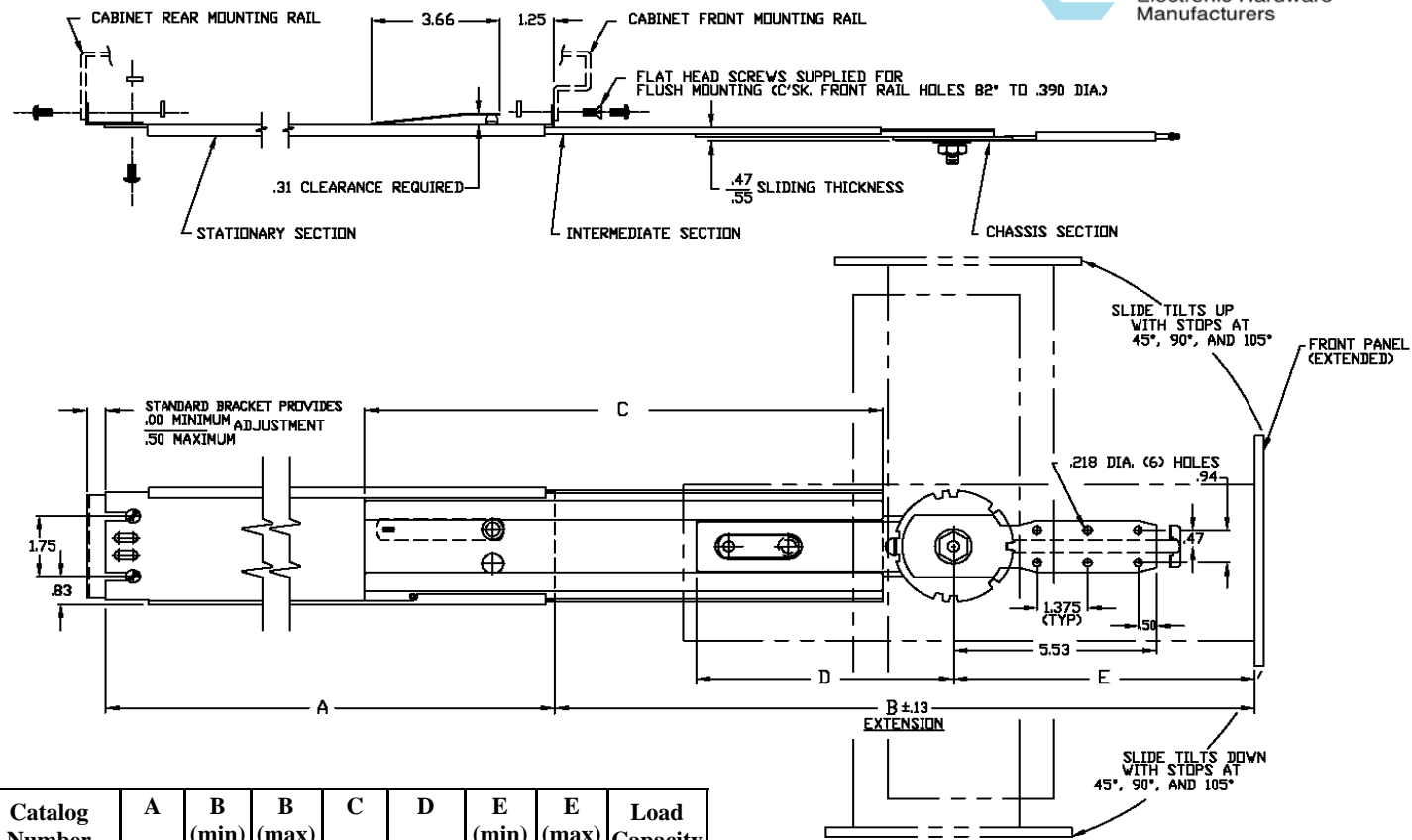

Catalog Number	A	B (min)	B (max)	C	D	E (min)	E (max)	Load Capacity
CTHD-114	14.00	15.13	15.63	13.00	7.00	6.50	7.00	275 LBS.
CTHD-116	16.00	19.00	19.63	15.00	8.88	6.50	7.13	275 LBS.
CTHD-118	18.00	21.00	23.63	17.00	8.88	6.50	9.13	275 LBS.
CTHD-120	20.00	23.00	27.63	19.00	8.88	6.50	11.13	275 LBS.
CTHD-122	22.00	23.88	29.63	21.00	9.75	6.50	12.25	275 LBS.
CTHD-124	24.00	24.25	31.63	23.00	9.75	6.87	14.25	275 LBS.

TO ORDER, SPECIFY



Stationary Section
 1 - Cabinet Mount
 2 - Strap Mount
 4 - Closed Slot

Length

AR - Automatic Release if desired

For information on Strap Mount option see page 28.

Notes

- Right hand shown, left hand opposite.
- Finish: All standard slides are coated with Poxylube™ dry film lubricant.
- All standard slides are designed to lock-out in the extended position and are available with an optional automatic release if lock-out is not desirable.
- Standard hardware packages include all the hardware necessary to mount your Chassis Trak® slides:
 - Rear mounting bracket (B-131) included
 - Bar Nuts (CA8056-06-0020)
 - #10-32 screws and keps nuts
- All sliding members of the standard slide are made from cold rolled steel.
- All Chassis Trak® solid bearing slides are supplied with a quick disconnect feature.
- Optional mounting patterns, slide lengths and extensions are available.
- Pickup tab available for units without a front panel.
- See safety recommendations for detent slides on page 9.
- For optional mounting brackets see pages 35.

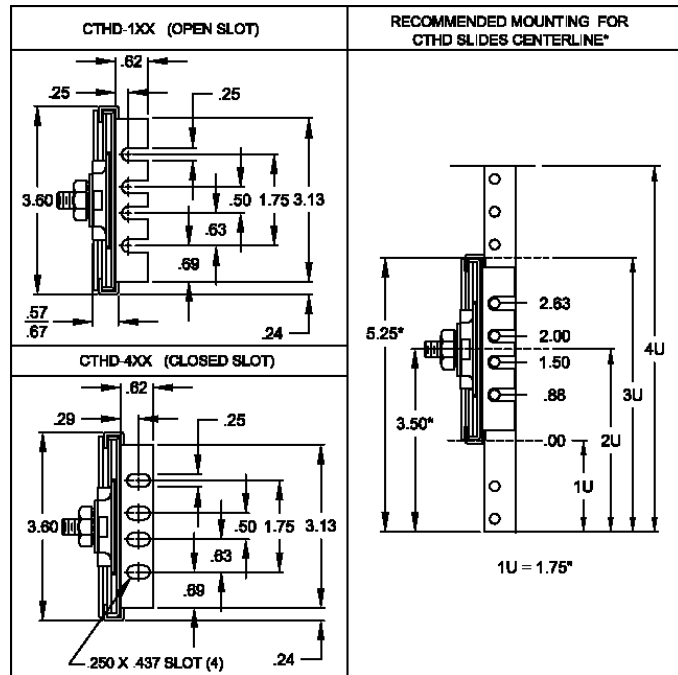

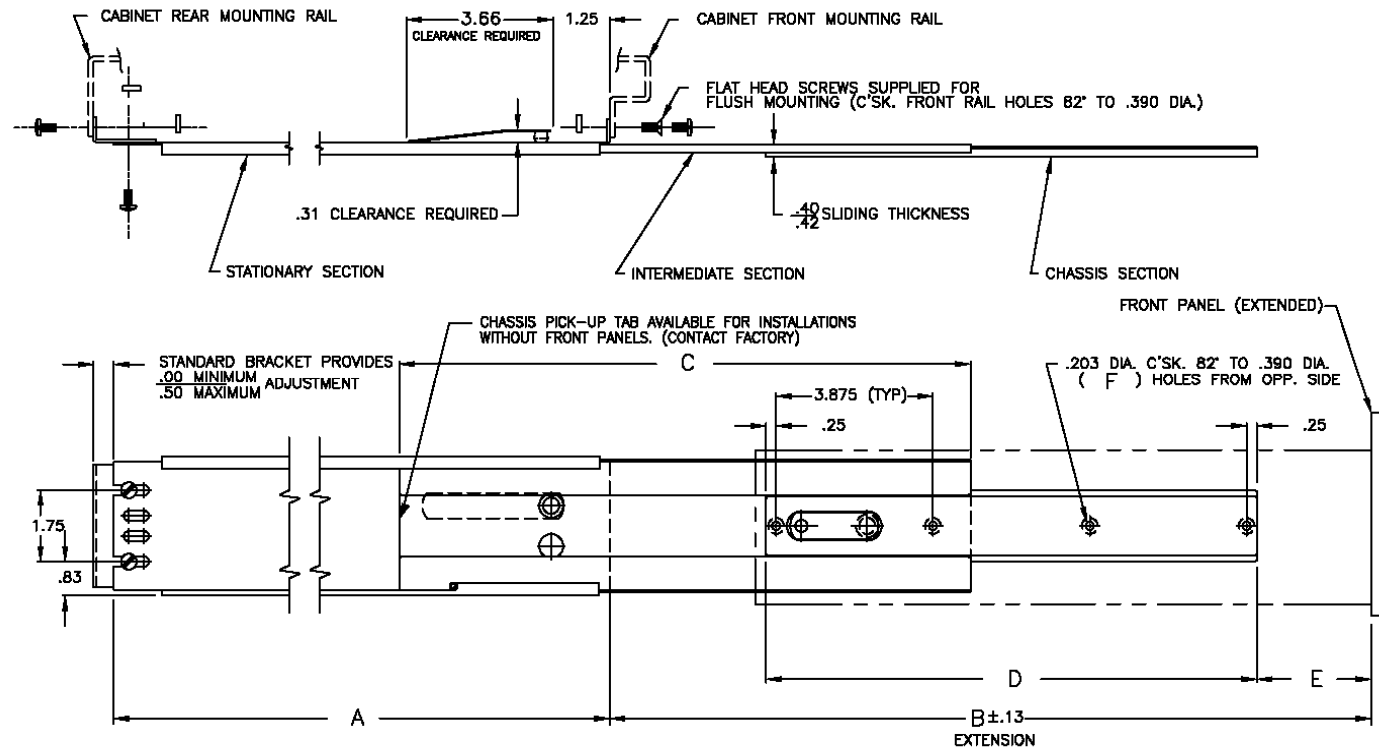

Catalog Number	A	B (min)	B (max)	C	D	E (min)	E (max)	F	Load Capacity
CTHS-114	14.00	13.75	15.63	13.00	12.13	0.00	1.88	4	275 LBS.
CTHS-116	16.00	15.75	19.63	15.00	12.13	0.00	3.88	4	275 LBS.
CTHS-118	18.00	21.63	23.63	17.00	16.00	0.00	2.00	5	275 LBS.
CTHS-120	20.00	23.63	27.63	19.00	16.00	0.00	4.00	5	275 LBS.
CTHS-122	22.00	23.63	29.63	21.00	16.00	0.00	6.00	5	275 LBS.
CTHS-124	24.00	24.25	31.63	23.00	16.00	0.63	8.00	5	275 LBS.

TO ORDER, SPECIFY



Stationary Section
 1 - Cabinet Mount
 2 - Strap Mount
 4 - Closed Slot

Length

AR - Automatic Release if desired

For information on Strap Mount option see page 28.

Notes

- Right hand shown, left hand opposite.
- Finish: All standard slides are coated with Poxylube™ dry film lubricant.
- All standard slides are designed to lock-out in the extended position and are available with an optional automatic release if lock-out is not desirable.
- Standard hardware packages include all the hardware necessary to mount your Chassis Trak® slides:
 - Rear mounting bracket (B-131) included
 - Bar Nuts (CA8056-06-0020)
 - #10-32 screws and keps nuts
- All sliding members of the standard slide are made from cold rolled steel.
- All Chassis Trak® solid bearing slides are supplied with a quick disconnect feature.
- Optional mounting patterns, slide lengths and extensions are available.
- Pickup tab available for units without a front panel.
- For optional mounting brackets see page 35.

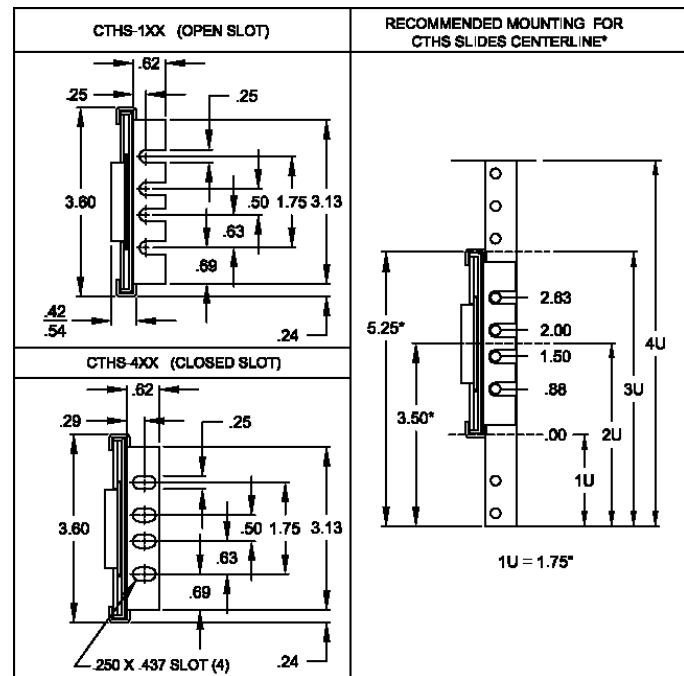

CTHRD Pivot Slide

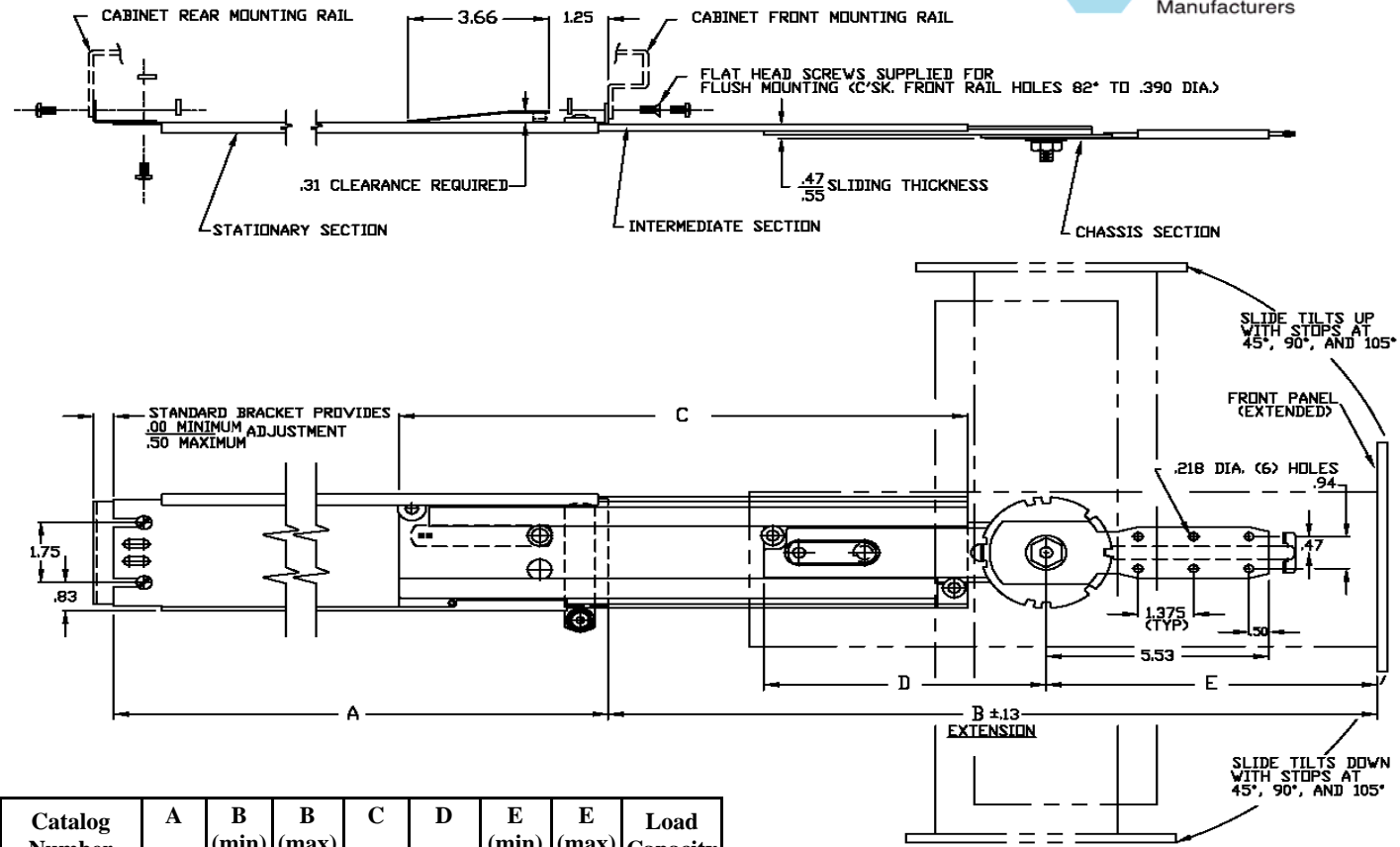

Catalog Number	A	B (min)	B (max)	C	D	E (min)	E (max)	Load Capacity
CTHRD-114	14.00	15.13	15.63	13.00	7.00	6.50	7.00	275 LBS.
CTHRD-116	16.00	19.00	19.63	15.00	8.88	6.50	7.13	275 LBS.
CTHRD-118	18.00	21.00	23.63	17.00	8.88	6.50	9.13	275 LBS.
CTHRD-120	20.00	23.00	27.63	19.00	8.88	6.50	11.13	275 LBS.
CTHRD-122	22.00	23.88	29.63	21.00	9.75	6.50	12.25	275 LBS.
CTHRD-124	24.00	24.25	31.63	23.00	9.75	6.88	14.25	275 LBS.

TO ORDER, SPECIFY

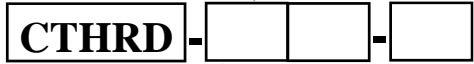

Stationary Section Length AR - Automatic Release if desired
 1 - Cabinet Mount
 2 - Strap Mount
 4 - Closed Slot

For information on Strap Mount option see page 28.

Notes

1. Right hand shown, left hand opposite.
2. Finish: All standard slides are coated with Poxylube™ dry film lubricant.
3. All standard slides are designed to lock-out in the extended position and are available with an optional automatic release if lock-out is not desirable.
4. Standard hardware packages include all the hardware necessary to mount your Chassis Trak® slides:
 - Rear mounting bracket (B-131) included
 - Bar Nuts (CA8056-06-0020)
 - #10-32 screws and keps nuts
5. All sliding members of the standard slide are made from cold rolled steel.
6. All Chassis Trak® solid bearing slides are supplied with a quick disconnect feature.
7. Optional mounting patterns, slide lengths and extensions are available.
8. Pickup tab available for units without a front panel.
9. See safety recommendations for detent slides on page 9.
10. For optional mounting brackets see pages 35.

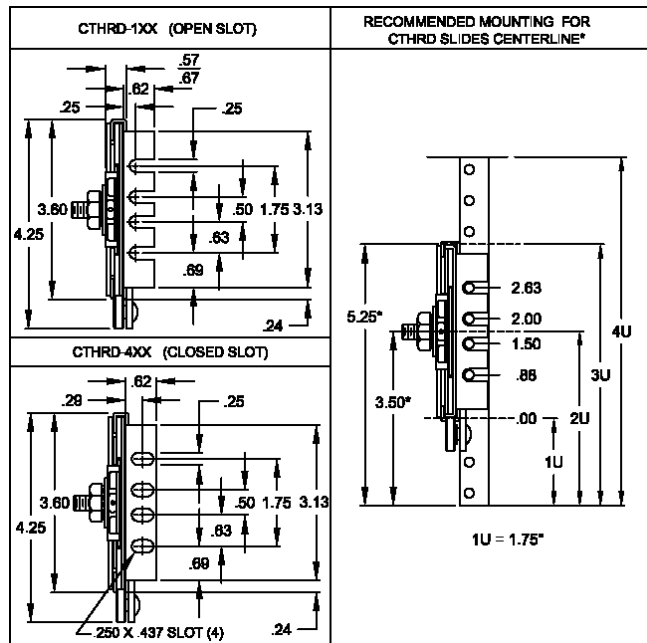

CTHRS Slide

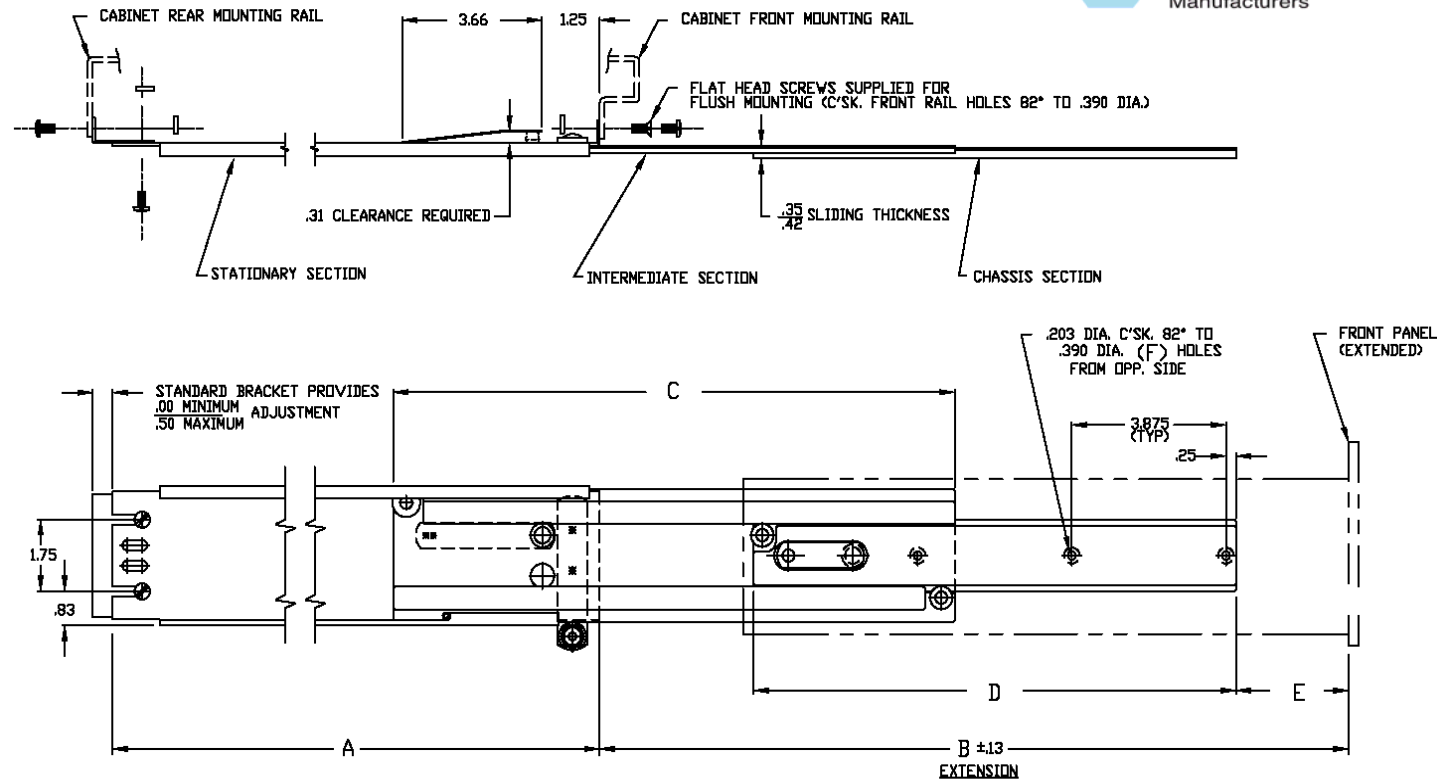

Catalog Number	A	B (min)	B (max)	C	D	E (min)	E (max)	F	Load Capacity
CTHRS-114	14.00	13.75	15.63	13.00	12.13	0.00	1.88	3	275 LBS.
CTHRS-116	16.00	15.75	19.63	15.00	12.13	0.00	3.88	3	275 LBS.
CTHRS-118	18.00	21.63	23.63	17.00	16.00	0.00	2.00	4	275 LBS.
CTHRS-120	20.00	23.63	27.63	19.00	16.00	0.00	4.00	4	275 LBS.
CTHRS-122	22.00	23.63	29.63	21.00	16.00	0.00	6.00	4	275 LBS.
CTHRS-124	24.00	24.25	31.63	23.00	16.00	0.63	8.00	4	275 LBS.

TO ORDER, SPECIFY



Stationary Section
 1 - Cabinet Mount
 2 - Strap Mount
 4 - Closed Slot

Length

AR - Automatic Release if desired

For information on Strap Mount option see page 28.

Notes

1. Right hand shown, left hand opposite.
2. Finish: All standard slides are coated with Poxylube™ dry film lubricant.
3. All standard slides are designed to lock-out in the extended position and are available with an optional automatic release if lock-out is not desirable.
4. Standard hardware packages include all the hardware necessary to mount your Chassis Trak® slides:
 - Rear mounting bracket (B-131) included
 - Bar nuts (CA8056-06-0020)
 - #10-32 screws and keps nuts
5. All sliding members of the standard slide are made from cold rolled steel.
6. All Chassis Trak® solid bearing slides are supplied with a quick disconnect feature.
7. Optional mounting patterns, slide lengths and extensions are available.
8. Pickup tab available for units without a front panel.
9. For optional mounting brackets see page 35.

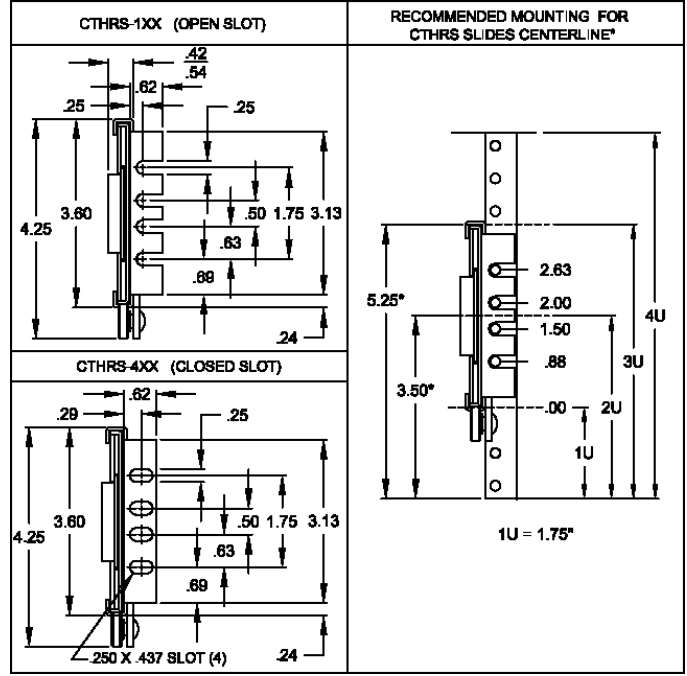

CTS and CTRS Special Application



Slide for Off-Set Leg Mounting Rail

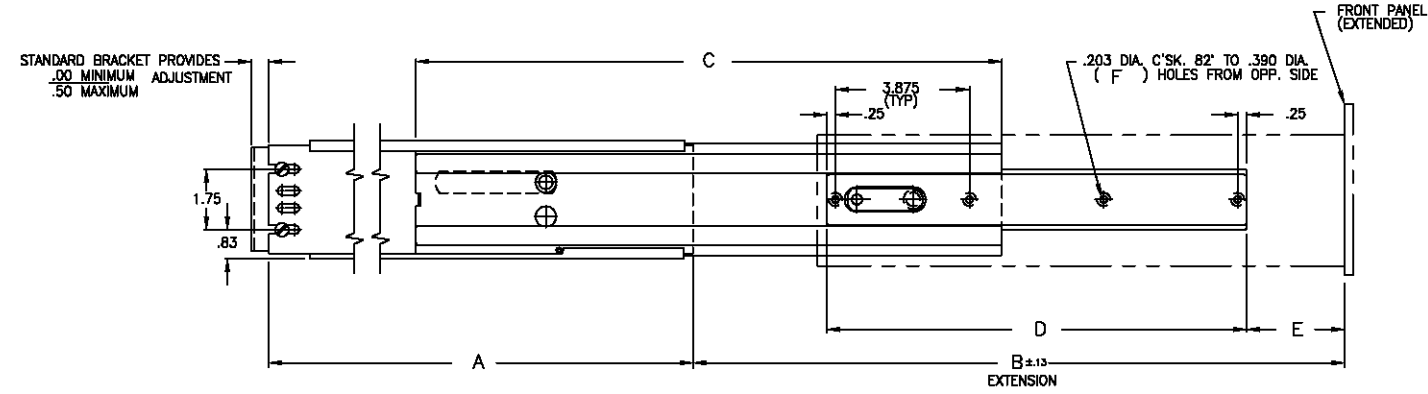
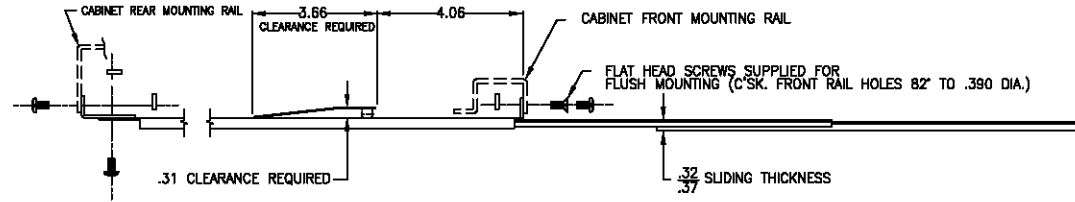

Catalog Number	A	B (min)	B (max)	C	D	E (min)	E (max)	F	Load Capacity
CTS-SA-114	14.00	13.50	14.25	13.00	12.13	0.0	.75	4	175 LBS.
CTS-SA-116	16.00	14.06	16.81	15.00	12.13	0.0	2.75	4	175 LBS.
CTS-SA-118	18.00	18.81	19.69	17.00	16.00	0.0	.88	5	175 LBS.
CTS-SA-120	20.00	20.81	23.69	19.00	16.00	0.0	2.88	5	175 LBS.
CTS-SA-122	22.00	23.31	27.69	21.00	16.00	.50	4.88	5	175 LBS.
CTS-SA-124	24.00	25.31	30.69	23.00	16.00	1.50	6.88	5	175 LBS.

TO ORDER, SPECIFY

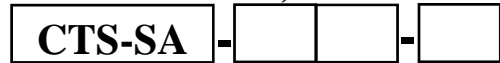

Stationary Section
1 - Cabinet Mount Length AR - Automatic Release if desired
4 - Closed Slot

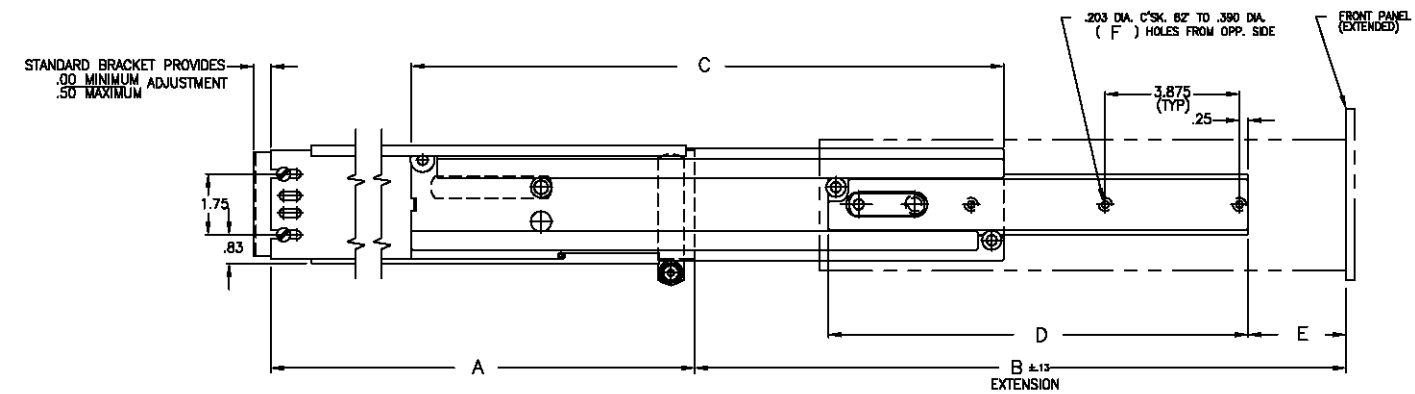
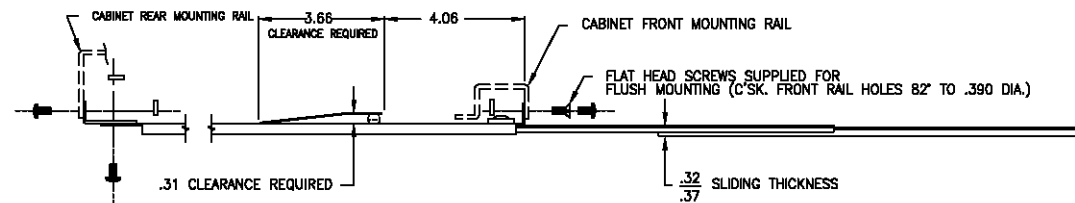

TO ORDER, SPECIFY

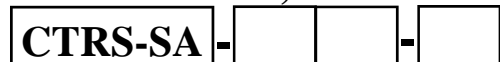

Stationary Section
1 - Cabinet Mount Length AR - Automatic Release if desired
4 - Closed Slot

Catalog Number	A	B (min)	B (max)	C	D	E (min)	E (max)	F	Load Capacity
CTRS-SA-114	14.00	13.50	14.25	13.00	12.13	0.0	.75	4	175 LBS.
CTRS-SA-116	16.00	14.06	16.81	15.00	12.13	0.0	2.75	4	175 LBS.
CTRS-SA-118	18.00	18.81	19.69	17.00	16.00	0.0	.88	5	175 LBS.
CTRS-SA-120	20.00	20.81	23.69	19.00	16.00	0.0	2.88	5	175 LBS.
CTRS-SA-122	22.00	23.31	27.69	21.00	16.00	.50	4.88	5	175 LBS.
CTRS-SA-124	24.00	25.31	30.69	23.00	16.00	1.50	6.88	5	175 LBS.

Strap Mounting Option



C-230 Strap Mount

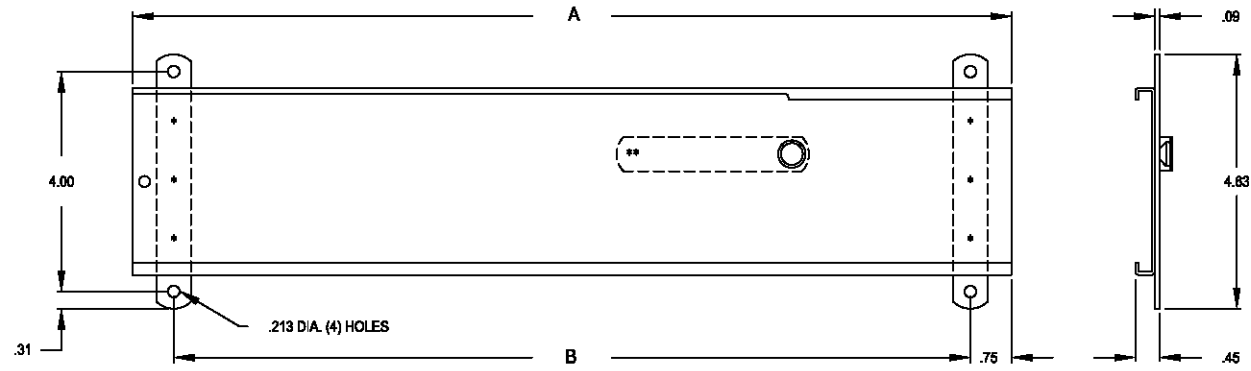

A	B
12.00	10.50
14.00	12.50
16.00	14.50
18.00	16.50
20.00	18.50
22.00	20.50
24.00	22.50

Notes

- To order, specify **C-230-S-2-XX** see pages 14-15 for more information.
- Strap mount slides are not designed to accommodate the standard EIA hole pattern.
- All slides requires a .31" clearance behind the spring and button assembly for proper operation.

C-300 Strap Mount

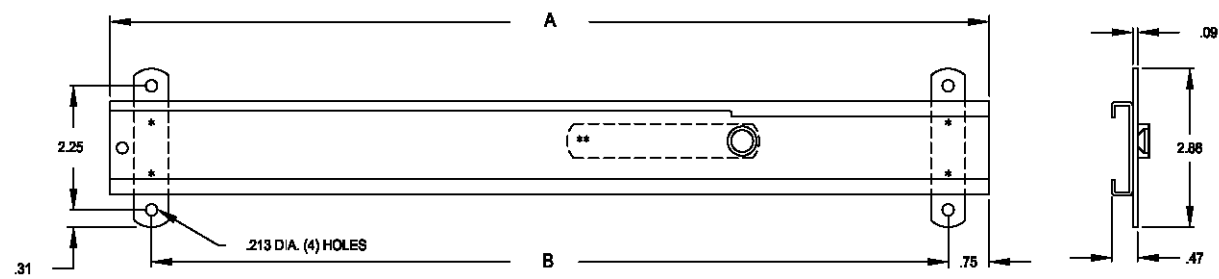

A	B
10.00	8.50
12.00	10.50
14.00	12.50
16.00	14.50
18.00	16.50
20.00	18.50
22.00	20.50
24.00	22.50
26.00	24.50
28.00	26.50
30.00	28.50

Notes

- To order, specify **C-300-S-2-XX** see pages 16-17 for more information.
- Strap mount slides are not designed to accommodate the standard EIA hole pattern.
- All slides requires a .31" clearance behind the spring and button assembly for proper operation.

CTS Strap Mount

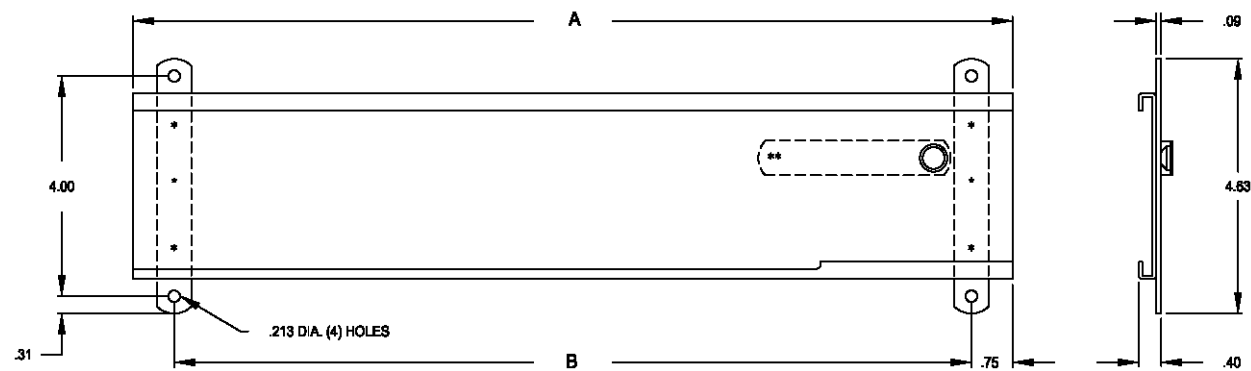

A	B
12.00	10.50
14.00	12.50
16.00	14.50
18.00	16.50
20.00	18.50
22.00	20.50
24.00	22.50

Notes

- To order, specify **CTS-2-XX** see pages 18-19 for more information.
- Strap mount slides are not designed to accommodate the standard EIA hole pattern.
- All slides requires a .31" clearance behind the spring and button assembly for proper operation.

Strap Mounting Option



CTRS Strap Mount

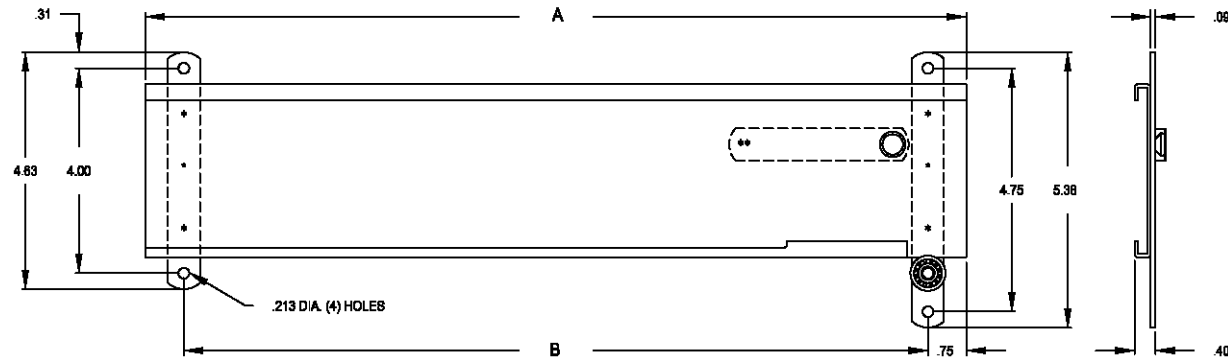

A	B
12.00	10.50
14.00	12.50
16.00	14.50
18.00	16.50
20.00	18.50
22.00	20.50
24.00	22.50

Notes

1. To order, specify **CTRS-2[XX]** see pages 20-21 for more information.
2. Strap mount slides are not designed to accommodate the standard EIA hole pattern.
3. All slides requires a .31" clearance behind the spring and button assembly for proper operation.

CTHS Strap Mount

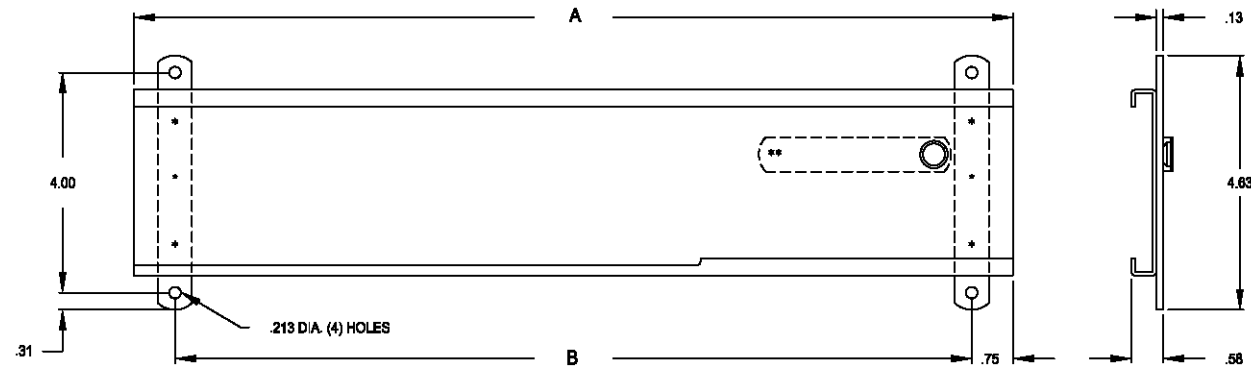

A	B
12.00	10.50
14.00	12.50
16.00	14.50
18.00	16.50
20.00	18.50
22.00	20.50
24.00	22.50

Notes

1. To order, specify **CTHS-2[XX]** see pages 22-23 for more information.
2. Strap mount slides are not designed to accommodate the standard EIA hole pattern.
3. All slides requires a .31" clearance behind the spring and button assembly for proper operation.

CTHRS Strap Mount

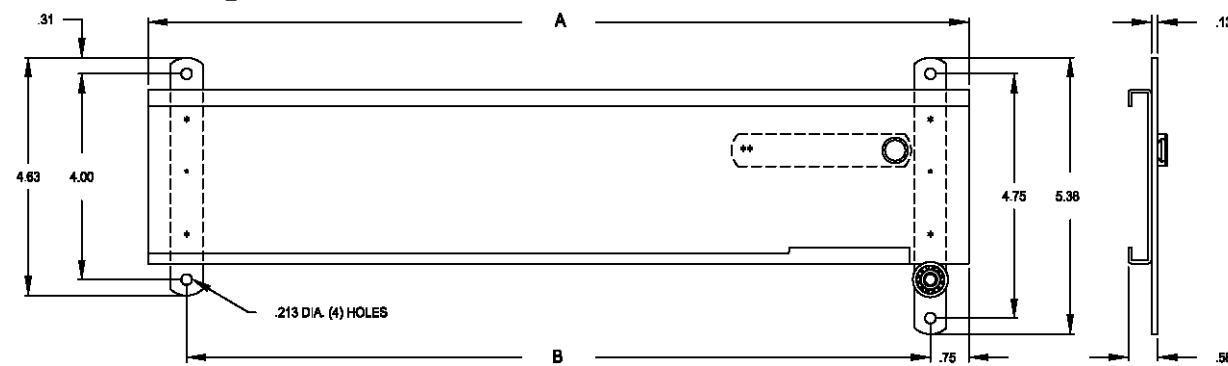

A	B
12.00	10.50
14.00	12.50
16.00	14.50
18.00	16.50
20.00	18.50
22.00	20.50
24.00	22.50

Notes

1. To order, specify **CTHRS-2[XX]** see pages 24-25 for more information.
2. Strap mount slides are not designed to accommodate the standard EIA hole pattern.
3. All slides requires a .31" clearance behind the spring and button assembly for proper operation.

C-3700 Two Section Slide

**Ultra-Thin Solid Bearing Slide*

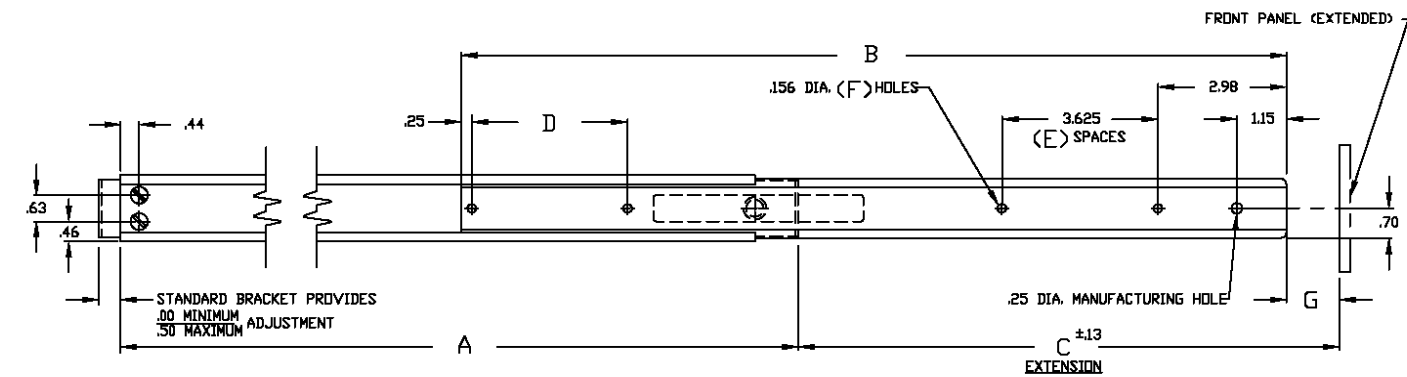
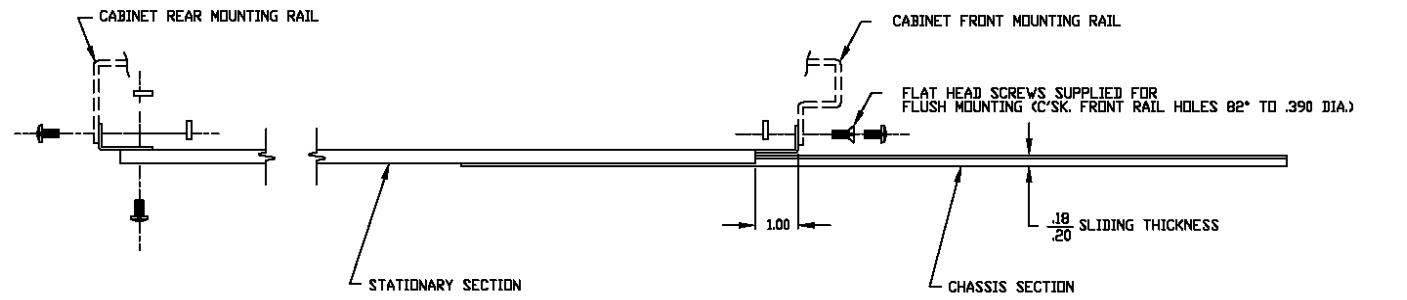

Catalog Number	A	B	C (MIN)	C (MAX)	D	E	F	G (MIN)	G (MAX)	Load Capacity
C-3700-12	12.00	10.13	6.22	7.45	NONE	NONE	2	0.00	1.23	85 LBS.
C-3700-14	14.00	12.13	7.72	8.95	NONE	NONE	2	0.00	1.23	80 LBS.
C-3700-16	16.00	14.13	9.22	10.45	NONE	1	3	0.00	1.23	80 LBS.
C-3700-18	18.00	16.13	10.72	11.95	NONE	1	3	0.00	1.23	75 LBS.
C-3700-20	20.00	18.13	12.22	13.45	NONE	2	4	0.00	1.23	75 LBS.
C-3700-22	22.00	20.13	13.22	14.45	NONE	2	4	0.00	1.23	70 LBS.
C-3700-24	24.00	22.13	14.72	15.95	NONE	2	4	0.00	1.23	70 LBS.
C-3700-26	26.00	24.13	16.22	17.45	3.625	3	6	0.00	1.23	65 LBS.
C-3700-28	28.00	26.13	17.22	18.45	3.625	3	6	0.00	1.23	65 LBS.
C-3700-30	30.00	28.13	18.72	19.45	3.625	3	6	0.00	1.23	60 LBS.

TO ORDER, SPECIFY

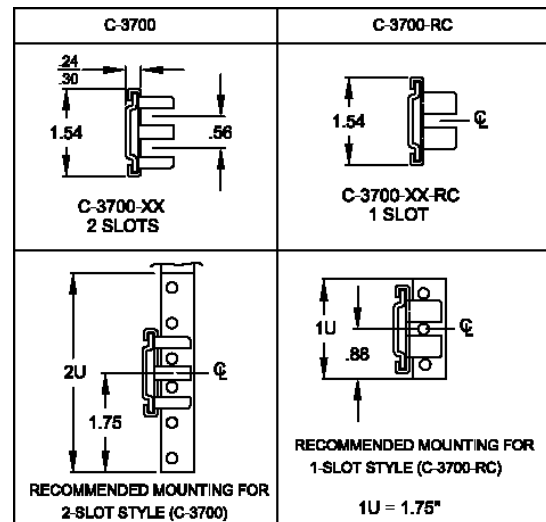
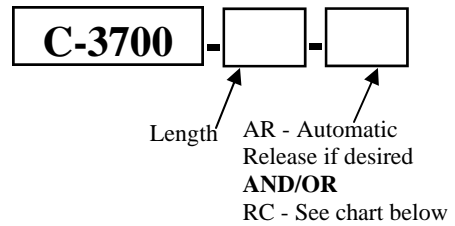

Notes

1. Finish: All standard slides are coated with Poxylube™ dry film lubricant.
2. All standard slides are designed to lock-out in the extended position and are available with an optional automatic release if lock-out is not desirable.
3. Standard hardware packages include all the hardware necessary to mount your Chassis Trak® slides:
 - Rear mounting bracket (B-217 or B-161) included
 - Bar Nuts (CA8056-06-0017 or CA8056-06-0014)
 - #6-32 screws and keps nuts to mount chassis section
 - #10-32 screws and keps nuts to mount slide in rack
4. All sliding members of the standard slide are made from cold rolled steel.
5. All Chassis Trak® solid bearing slides are supplied with a quick disconnect feature.
6. Optional mounting patterns, slide lengths and extensions are available.
7. For optional mounting brackets see page 34.

C-649 Two Section Slide

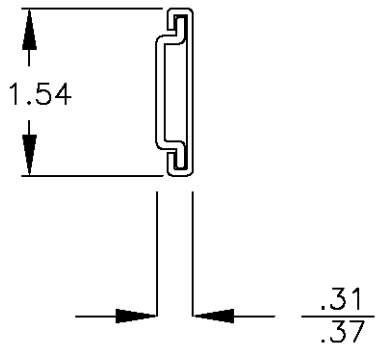
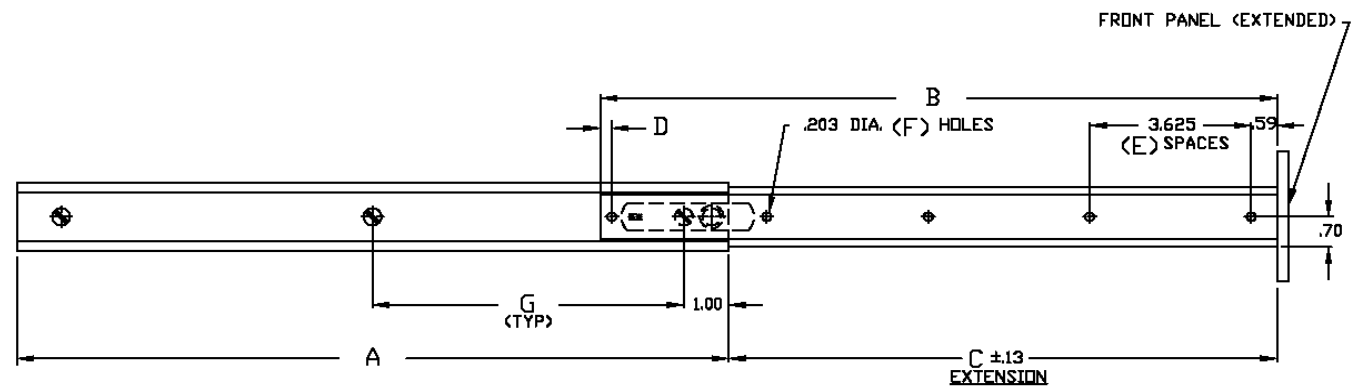
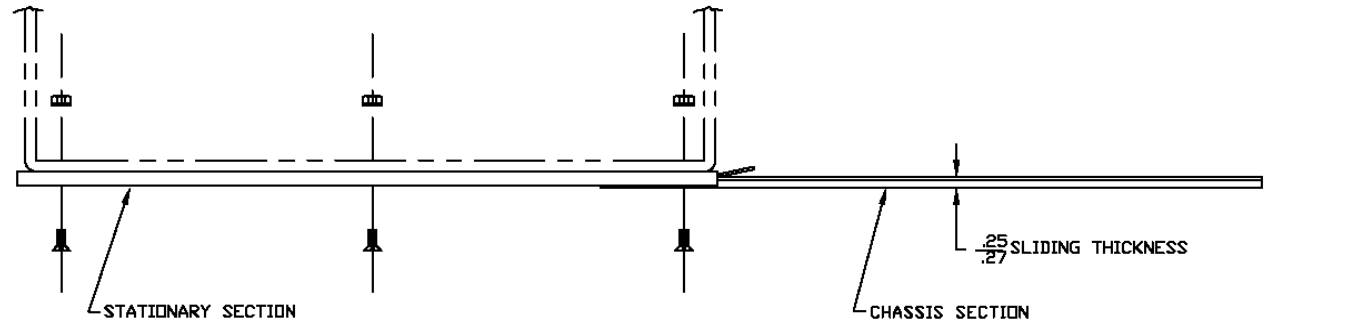

TO ORDER, SPECIFY

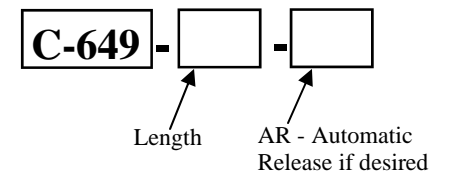

Catalog Number	A	B	C	D	E	F	G	Load Capacity
C-649-10	10.00	9.25	7.00	NONE	1	2	4.00	95 LBS.
C-649-12	12.00	11.25	9.00	NONE	2	3	5.00	95 LBS.
C-649-14	14.00	13.25	10.50	NONE	2	3	6.00	90 LBS.
C-649-16	16.00	15.25	12.00	0.25	2	4	7.00	90 LBS.
C-649-18	18.00	17.25	13.50	0.25	3	5	8.00	90 LBS.
C-649-20	20.00	19.25	15.00	0.25	3	5	9.00	85 LBS.
C-649-22	22.00	21.25	16.50	0.25	4	6	10.00	85 LBS.
C-649-24	24.00	23.25	18.00	0.25	4	6	11.00	85 LBS.
C-649-26	26.00	25.25	19.50	0.25	4	6	12.00	80 LBS.
C-649-28	28.00	27.25	21.00	0.25	5	7	13.00	80 LBS.
C-649-30	30.00	29.25	22.50	0.25	5	7	14.00	80 LBS.

Notes

1. Finish: All standard slides are coated with Poxylube™ dry film lubricant.
2. All standard slides are designed to lock-out in the extended position and are available with an optional automatic release if lock-out is not desirable.
3. Standard hardware packages include all the hardware necessary to mount your Chassis Trak® slides:
 - #10-32 and #8-32 screws and keps nuts
4. All sliding members of the standard slide are made from cold rolled steel.
5. All Chassis Trak® solid bearing slides are supplied with a quick disconnect feature.
6. Optional mounting patterns, slide lengths and extensions are available.

C-874 Two Section Slide

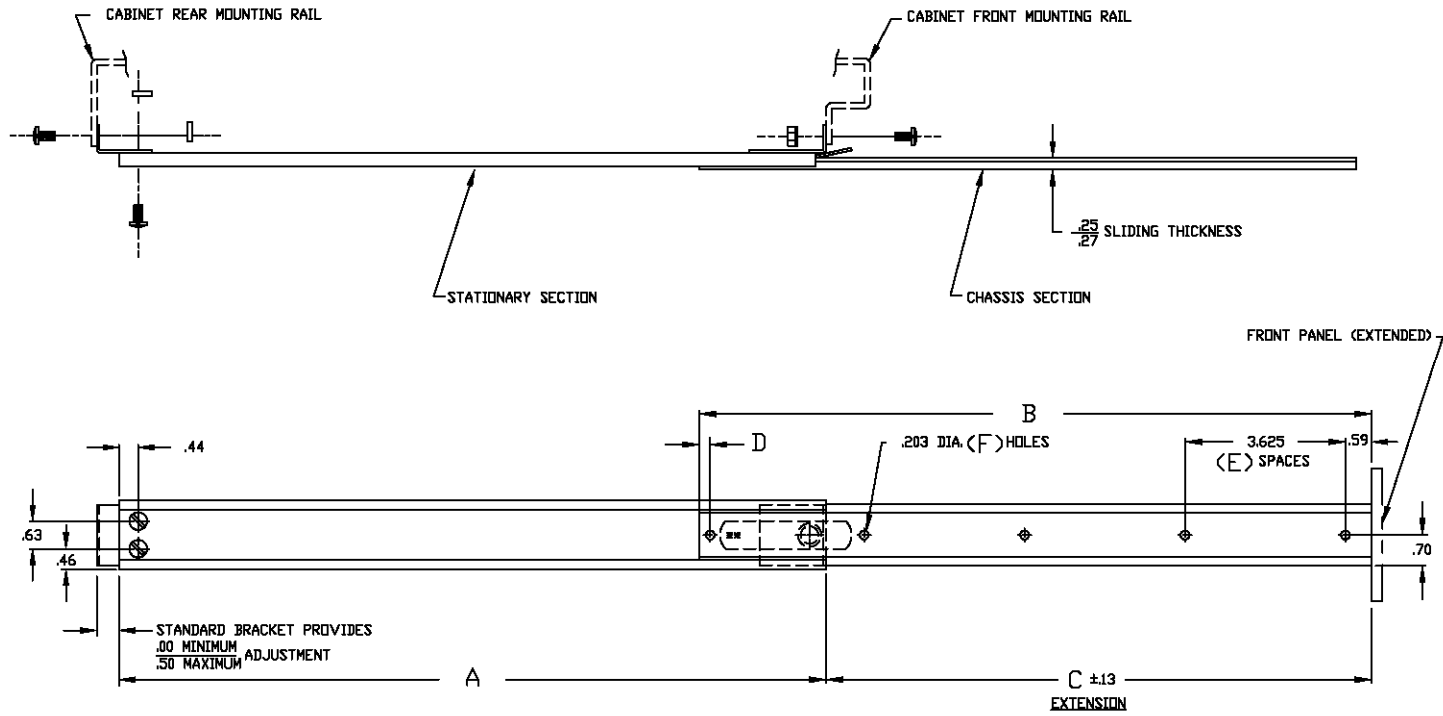

Catalog Number	A	B	C	D	E	F	Load Capacity
C-874-10	10.00	9.25	7.00	NONE	1	2	95 LBS.
C-874-12	12.00	11.25	9.00	NONE	2	3	95 LBS.
C-874-14	14.00	13.25	10.50	NONE	2	3	90 LBS.
C-874-16	16.00	15.25	12.00	0.25	2	4	90 LBS.
C-874-18	18.00	17.25	13.50	0.25	3	5	90 LBS.
C-874-20	20.00	19.25	15.00	0.25	3	5	85 LBS.
C-874-22	22.00	21.25	16.50	0.25	4	6	85 LBS.
C-874-24	24.00	23.25	18.00	0.25	4	6	85 LBS.
C-874-26	26.00	25.25	19.50	0.25	4	6	80 LBS.
C-874-28	28.00	27.25	21.00	0.25	5	7	80 LBS.
C-874-30	30.00	29.25	22.50	0.25	5	7	80 LBS.

TO ORDER, SPECIFY

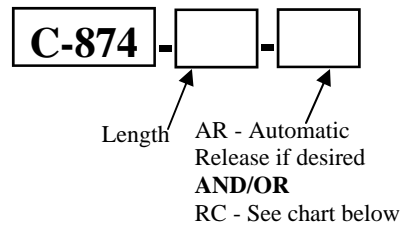

Notes

1. Finish: All standard slides are coated with Poxylube™ dry film lubricant.
2. All standard slides are designed to lock-out in the extended position and are available with an optional automatic release if lock-out is not desirable.
3. Standard hardware packages include all the hardware necessary to mount your Chassis Trak® slides:
 - Rear mounting bracket (B-217 or B-161) included
 - Bar Nuts (CA8056-06-0017 or CA8056-06-0014)
 - #10-32 screws and keps nuts
4. All sliding members of the standard slide are made from cold rolled steel.
5. All Chassis Trak® solid bearing slides are supplied with a quick disconnect feature.
6. Optional mounting patterns, slide lengths and extensions are available.
7. For optional mounting brackets see page 34.

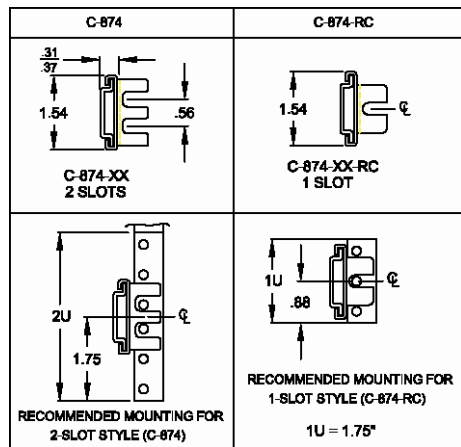

C-857 Two Section Slide

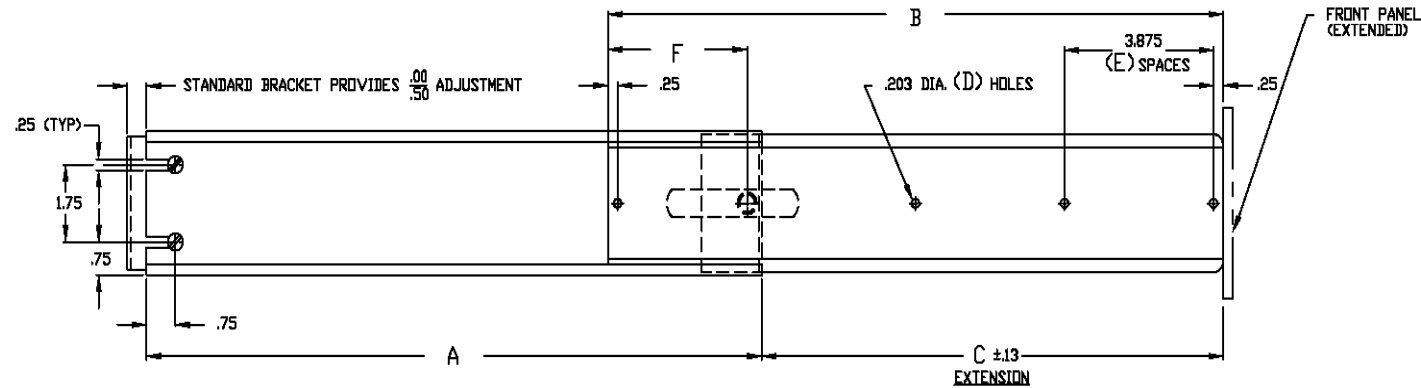
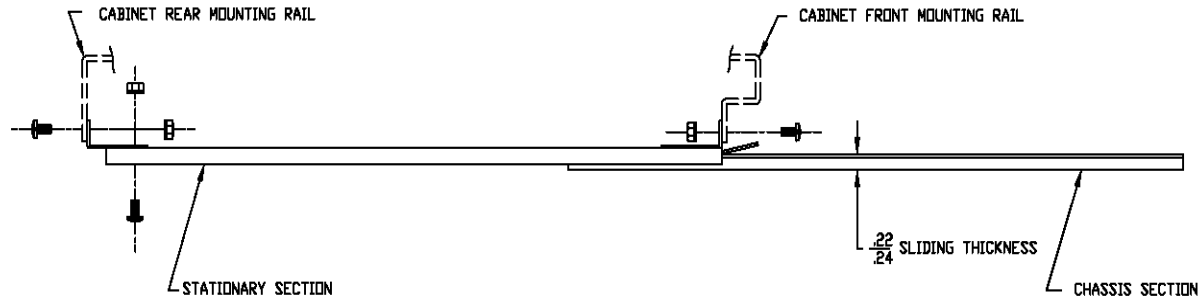

Catalog Number	A	B	C	D	E	F	Load Capacity
C-857-10	10.00	10.00	7.50	2	1	2.13	140 LBS.
C-857-12	12.00	12.00	9.00	4	2	2.63	140 LBS.
C-857-14	14.00	14.00	10.50	4	2	3.13	135 LBS.
C-857-16	16.00	16.00	12.00	4	2	3.63	135 LBS.
C-857-18	18.00	18.00	13.50	5	3	4.13	135 LBS.
C-857-20	20.00	20.00	15.00	5	3	4.63	130 LBS.
C-857-22	22.00	22.00	16.50	5	3	5.13	130 LBS.
C-857-24	24.00	24.00	18.00	6	4	5.63	130 LBS.
C-857-26	26.00	26.00	19.50	6	4	6.13	125 LBS.
C-857-28	28.00	28.00	21.00	6	4	6.63	125 LBS.
C-857-30	30.00	30.00	22.50	6	4	7.13	125 LBS.

TO ORDER, SPECIFY

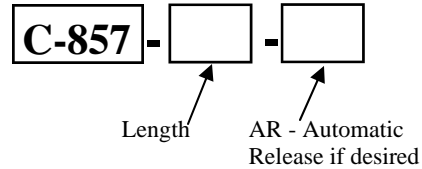

Notes

1. Finish: All standard slides are coated with Poxylube™ dry film lubricant.
2. All standard slides are designed to lock-out in the extended position and are available with an optional automatic release if lock-out is not desirable.
3. Standard hardware packages include all the hardware necessary to mount your Chassis Trak® slides:
 - Rear mounting bracket (B-131) included
 - Bar Nuts (CA8056-06-0020)
 - #10-32 screws and keps nuts
4. All sliding members of the standard slide are made from cold rolled steel.
5. All Chassis Trak® solid bearing slides are supplied with a quick disconnect feature.
6. Optional mounting patterns, slide lengths and extensions are available.
7. For optional mounting brackets see page 35.

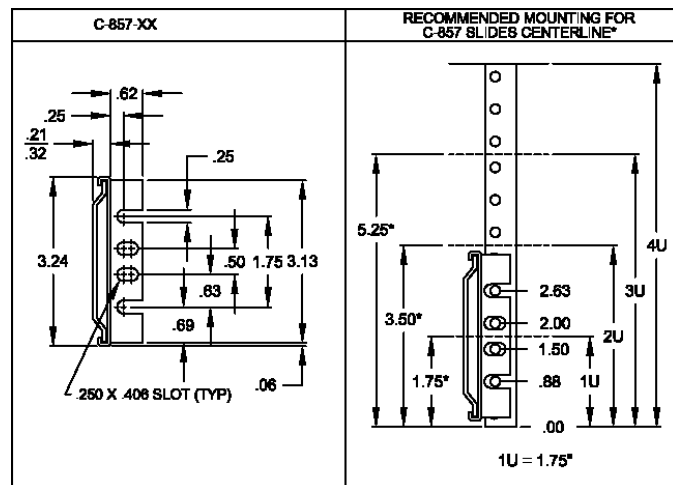

C-917 Two Section Slide

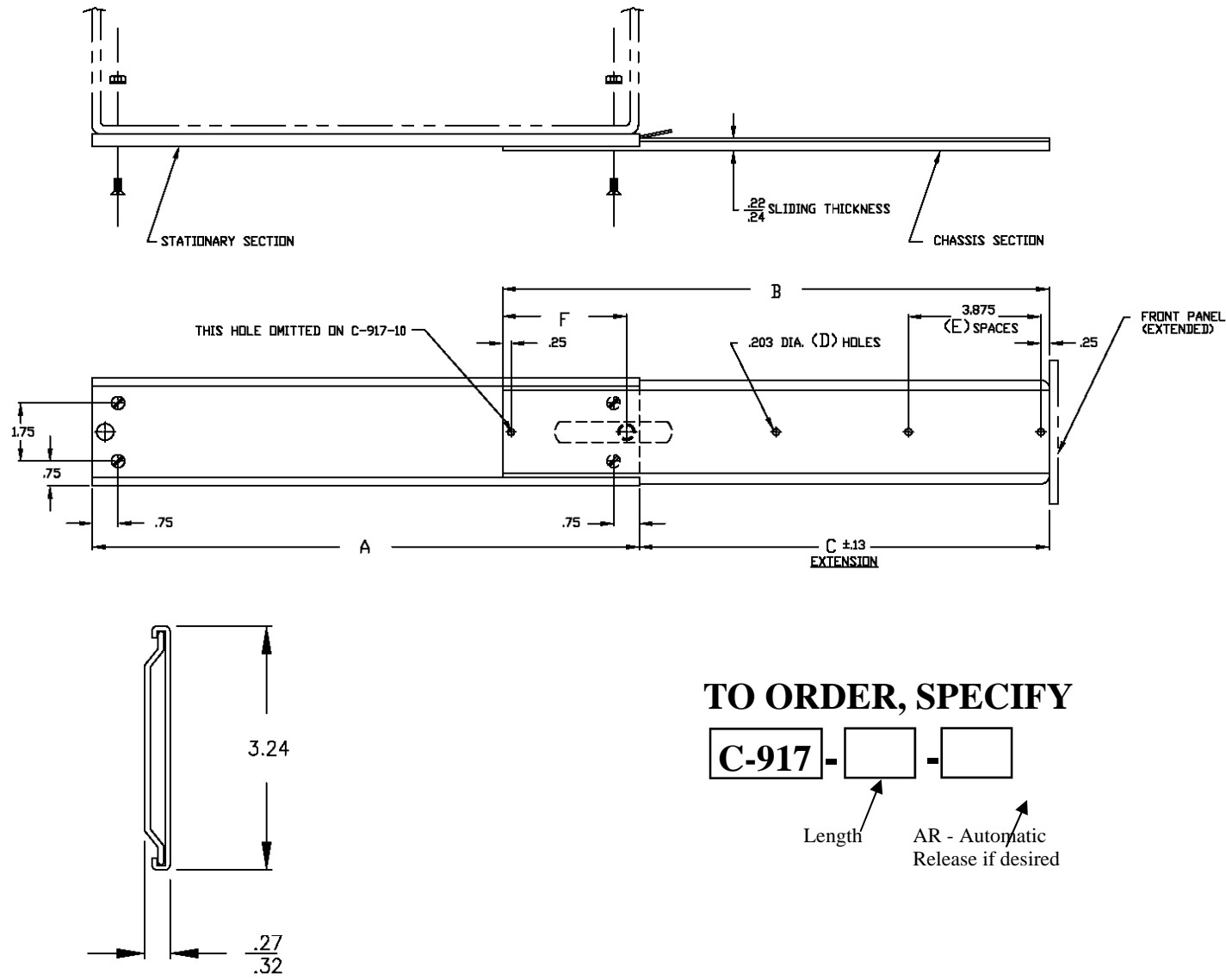

TO ORDER, SPECIFY

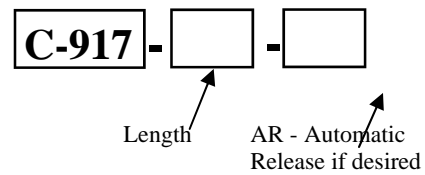

Catalog Number	A	B	C	D	E	F	Load Capacity
C-917-10	10.00	10.00	7.50	2	1	2.13	140 LBS.
C-917-12	12.00	12.00	9.00	4	2	2.63	140 LBS.
C-917-14	14.00	14.00	10.50	4	2	3.13	135 LBS.
C-917-16	16.00	16.00	12.00	4	2	3.63	135 LBS.
C-917-18	18.00	18.00	13.50	5	3	4.13	135 LBS.
C-917-20	20.00	20.00	15.00	5	3	4.63	130 LBS.
C-917-22	22.00	22.00	16.50	5	3	5.13	130 LBS.
C-917-24	24.00	24.00	18.00	6	4	5.63	130 LBS.
C-917-26	26.00	26.00	19.50	6	4	6.13	125 LBS.
C-917-28	28.00	28.00	21.00	6	4	6.63	125 LBS.
C-917-30	30.00	30.00	22.50	6	4	7.13	125 LBS.

Notes

1. Finish: All standard slides are coated with Poxylube™ dry film lubricant.
2. All standard slides are designed to lock-out in the extended position and are available with an optional automatic release if lock-out is not desirable.
3. Standard hardware packages include all the hardware necessary to mount your Chassis Trak® slides:
 - #10-32 screws and keps nuts
4. All sliding members of the standard slide are made from cold rolled steel.
5. All Chassis Trak® solid bearing slides are supplied with a quick disconnect feature.
6. Optional mounting patterns, slide lengths and extensions are available.

Optional Mounting Brackets



Matrix For Solid Bearing Slides & Appropriate Rear Mounting Brackets with Range of Extension									
	B-217*	B-217-1.5	B-217-2	B-217-2.5	B-217-3	B-217-3.5	B-217-4	B-308	B-793
C-300-D	0 to .50	.25 to .75	.75 to 1.25	1.25 to 1.75	1.75 to 2.25	2.25 to 2.75	2.75 to 3.25	0 to 6.00	0 to 6.00
C-300-S	0 to .50	.25 to .75	.75 to 1.25	1.25 to 1.75	1.75 to 2.25	2.25 to 2.75	2.75 to 3.25	0 to 6.00	0 to 6.00
C-874	0 to .50	.25 to .75	.75 to 1.25	1.25 to 1.75	1.75 to 2.25	2.25 to 2.75	2.75 to 3.25		
C-3700	0 to .50	.25 to .75	.75 to 1.25	1.25 to 1.75	1.75 to 2.25	2.25 to 2.75	2.75 to 3.25		

	B-161*	B-161-1.5	B-161-2	B-161-2.5	B-161-3	B-161-3.5	B-161-4	B-309	B-389
C-300-D-RC	0 to .50	.25 to .75	.75 to 1.25	1.25 to 1.75	1.75 to 2.25	2.25 to 2.75	2.75 to 3.25	0 to 6.00	
C-300-S-RC	0 to .50	.25 to .75	.75 to 1.25	1.25 to 1.75	1.75 to 2.25	2.25 to 2.75	2.75 to 3.25	0 to 6.00	
C-300-S-RC-3S									0 to 6.00
C-874-RC	0 to .50	.25 to .75	.75 to 1.25	1.25 to 1.75	1.75 to 2.25	2.25 to 2.75	2.75 to 3.25	0 to 6.00	
C-3700-RC	0 to .50	.25 to .75	.75 to 1.25	1.25 to 1.75	1.75 to 2.25	2.25 to 2.75	2.75 to 3.25	0 to 6.00	

Note brackets are made from 16 gauge C.R.S. — Standard finish: clear zinc commercial plating

*Supplied with standard slides

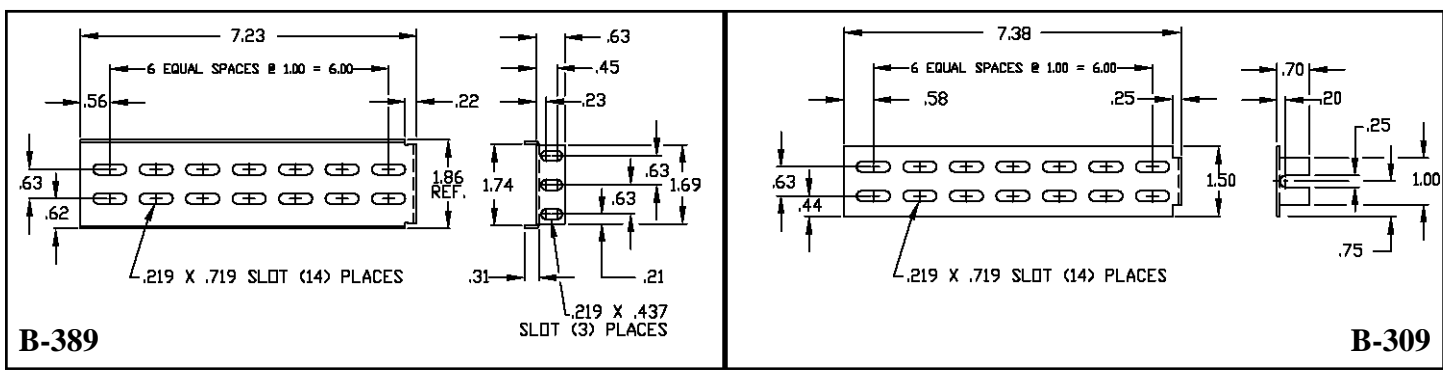
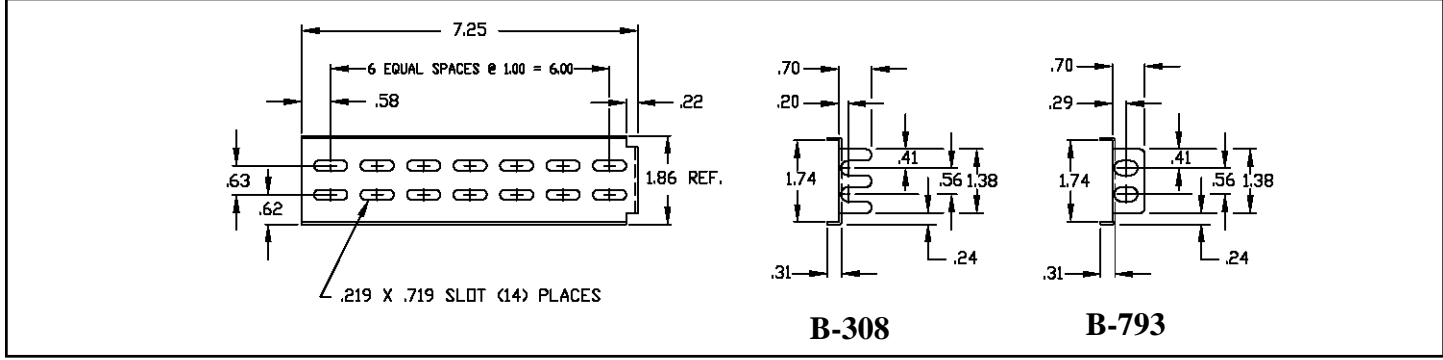
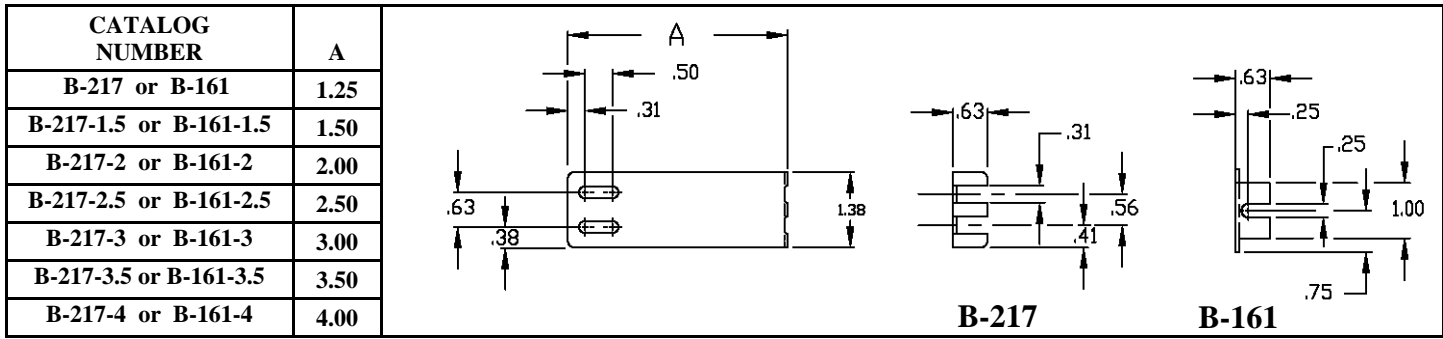

Optional Mounting Brackets



Matrix For Solid Bearing Slides & Appropriate Rear Mounting Brackets with Range of Extension										
	B-131*	B-131-2	B-131-2.5	B-131-3	B-131-3.5	B-131-4	B-307-1 B-814-1	B-307-2 B-814-2	B-810-1	B-810-2
C-230-D	0 to .50	.44 to 1.06	.94 to 1.56	1.44 to 2.06	1.94 to 2.56	2.44 to 3.06	0 to 4.00	0 to 8.00		
C-230-S	0 to .50	.44 to 1.06	.94 to 1.56	1.44 to 2.06	1.94 to 2.56	2.44 to 3.06	0 to 4.00	0 to 8.00		
CTD	0 to .50	.44 to 1.06	.94 to 1.56	1.44 to 2.06	1.94 to 2.56	2.44 to 3.06	0 to 4.00	0 to 8.00		
CTS	0 to .50	.44 to 1.06	.94 to 1.56	1.44 to 2.06	1.94 to 2.56	2.44 to 3.06	0 to 4.00	0 to 8.00		
CTRD	0 to .50	.44 to 1.06	.94 to 1.56	1.44 to 2.06	1.94 to 2.56	2.44 to 3.06	0 to 4.00	0 to 8.00		
CTRS	0 to .50	.44 to 1.06	.94 to 1.56	1.44 to 2.06	1.94 to 2.56	2.44 to 3.06	0 to 4.00	0 to 8.00		
CTHD	0 to .50	.44 to 1.06	.94 to 1.56	1.44 to 2.06	1.94 to 2.56	2.44 to 3.06			0 to 4.00	0 to 8.00
CTHS	0 to .50	.44 to 1.06	.94 to 1.56	1.44 to 2.06	1.94 to 2.56	2.44 to 3.06			0 to 4.00	0 to 8.00
CTHRD	0 to .50	.44 to 1.06	.94 to 1.56	1.44 to 2.06	1.94 to 2.56	2.44 to 3.06			0 to 4.00	0 to 8.00
CTHRS	0 to .50	.44 to 1.06	.94 to 1.56	1.44 to 2.06	1.94 to 2.56	2.44 to 3.06			0 to 4.00	0 to 8.00
C-857	0 to .50	.44 to 1.06	.94 to 1.56	1.44 to 2.06	1.94 to 2.56	2.44 to 3.06				

Note brackets are made from 16 gauge C.R.S. — Standard finish: clear zinc commercial plating

*Supplied with standard slides

CATALOG NUMBER	A
B-131	1.56
B-131-2	2.00
B-131-2.5	2.50
B-131-3	3.00
B-131-3.5	3.50
B-131-4	4.00

.213 DIA. (4) HOLES

.25 (TYP)

.218 DIA. (C) NO. OF HOLES

B-307

B-810

B-814

CATALOG NUMBER	A	B	C
B-307-1 / B-810-1 / B-814-1	5.94	4.38	16
B-307-2 / B-810-2 / B-814-2	9.69	8.13	28

Ball Bearing Slides



Constructed from 14 gauge cold rolled steel, the LBS slides are designed for horizontal extension only and do not disconnect. Other non-standard options include: special markings, special extensions, special finishes, lock-in and complete design changes per customer request.

LBS Slides Available	Load Capacity
LBS-11 3/4 extension - 10" to 30" lengths available	50 to 145 lbs
LBS-12 Full extension - 10" to 30" lengths available	75 to 180 lbs.
LBS-O Over-and-under full extension - 10" to 30" lengths available	75 to 180 lbs.
LBS-21 Heavy duty 3/4 extension - 10" to 30" lengths available	160 to 250 lbs.
LBS-22 Heavy duty full extension - 10" to 30" lengths available	360 to 605 lbs.
LBS-32 Extra heavy duty full extension - 10" to 30" lengths available	510 to 930 lbs.



The CLB slides are constructed from 14 gauge cold rolled steel. Each model has a front quick disconnect feature and locks out at full extension. Other non-standard options include: special markings, special extensions, special finishes, lock-in and complete design changes per customer request.

CLB Slides Available	Load Capacity
CLB-203 3/4 extension w/quick disconnect - 10" to 30" lengths available.	50 to 145 lbs
CLB-223 Heavy duty 3/4 extension w/quick disconnect - 10" to 30" lengths available.	160 to 250 lbs.
CLB-305 Full extension w/Green Button release mechanism. Has .38 sliding thickness. Back mounted in between rails w/offset mounting brackets. 10" to 30" lengths available.	75 to 140 lbs.
CLB-307 Full extension w/Green Button release mechanism. Has .64 sliding thickness. 10" to 30" lengths available.	75 to 175 lbs.
CLB-315 Full extension w/Green Button release mechanism. Has .45 sliding thickness and is 3/16" tall w/gravity lock. 14" to 30" lengths available.	75 to 170 lbs.

LBS-11



(3/4) Extension Ball Bearing Slide

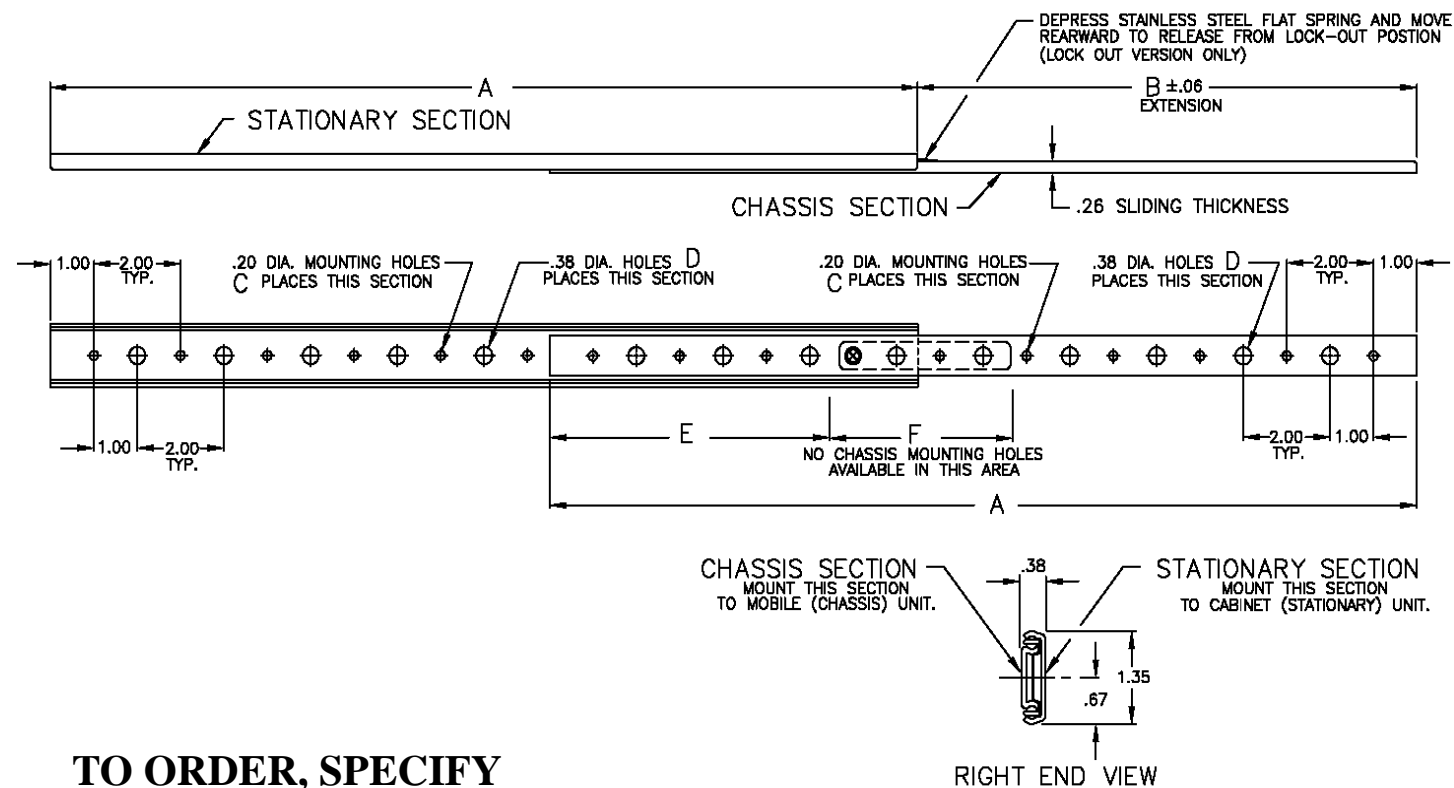

TO ORDER, SPECIFY

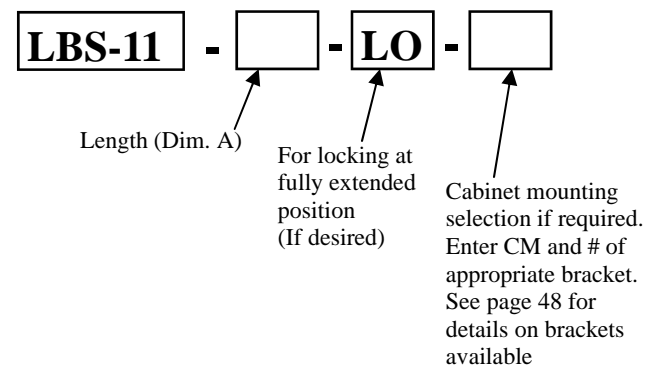

Notes

- LBS-11 consists of one set of two non-handed slides. Optional lock-out feature is available.
- All slides are supplied with special (.094" max. head height) #8-32x3/8 Phillips pan head screws and self-locking nuts for mounting one set of slides. Use only these special screws when mounting through slide member to prevent internal damage to ball retainer. If mounting to cabinet rails, see cabinet mounting section for ball bearing slides.
- LBS-11 does not disconnect.
- Slide members are made from 14 gauge (.074) work hardened cold rolled steel.
- Finish: clear zinc commercial plating.
- Holes other than those shown may be in part at manufacture's option.
- Load capacity is based on one set of slides at full extension with load (center of gravity) centered between the slides and at midpoint of the slide (chassis section). Load capacities have a 100% (static load) safety factor at full extension. The slides will support more than the stated capacities but are not designed to be operated at capacities greater than those stated.
- Grease applied to ball bearing slides has a temperature range of -45°F to +350°F.
- Odd length slides available, contact factory for more information.
- Other non-standard options which are available include: special marking, special extensions, special finishes, lock-in and complete design changes per customer request. Contact factory as these options will require a special reference number to assure receipt of specified options.

Catalog Number	A	B	C	D	E	F	Load Capacity
LBS-11-10	10.00	7.50	5	4	1.50	3.00	145 LBS.
LBS-11-12	12.00	9.00	6	5	1.50	3.00	140 LBS.
LBS-11-14	14.00	10.50	7	6	1.50	3.00	130 LBS.
LBS-11-16	16.00	12.00	8	7	1.50	5.00	120 LBS.
LBS-11-18	18.00	13.50	9	8	1.50	5.00	110 LBS.
LBS-11-20	20.00	15.00	10	9	1.50	5.00	95 LBS.
LBS-11-22	22.00	16.50	11	10	1.50	5.00	85 LBS.
LBS-11-24	24.00	18.00	12	11	1.50	7.00	80 LBS.
LBS-11-26	26.00	19.50	13	12	1.50	7.00	70 LBS.
LBS-11-28	28.00	21.00	14	13	3.50	5.00	60 LBS.
LBS-11-30	30.00	22.50	15	14	3.50	5.00	50 LBS.

LBS-12



Full Extension Ball Bearing Slide

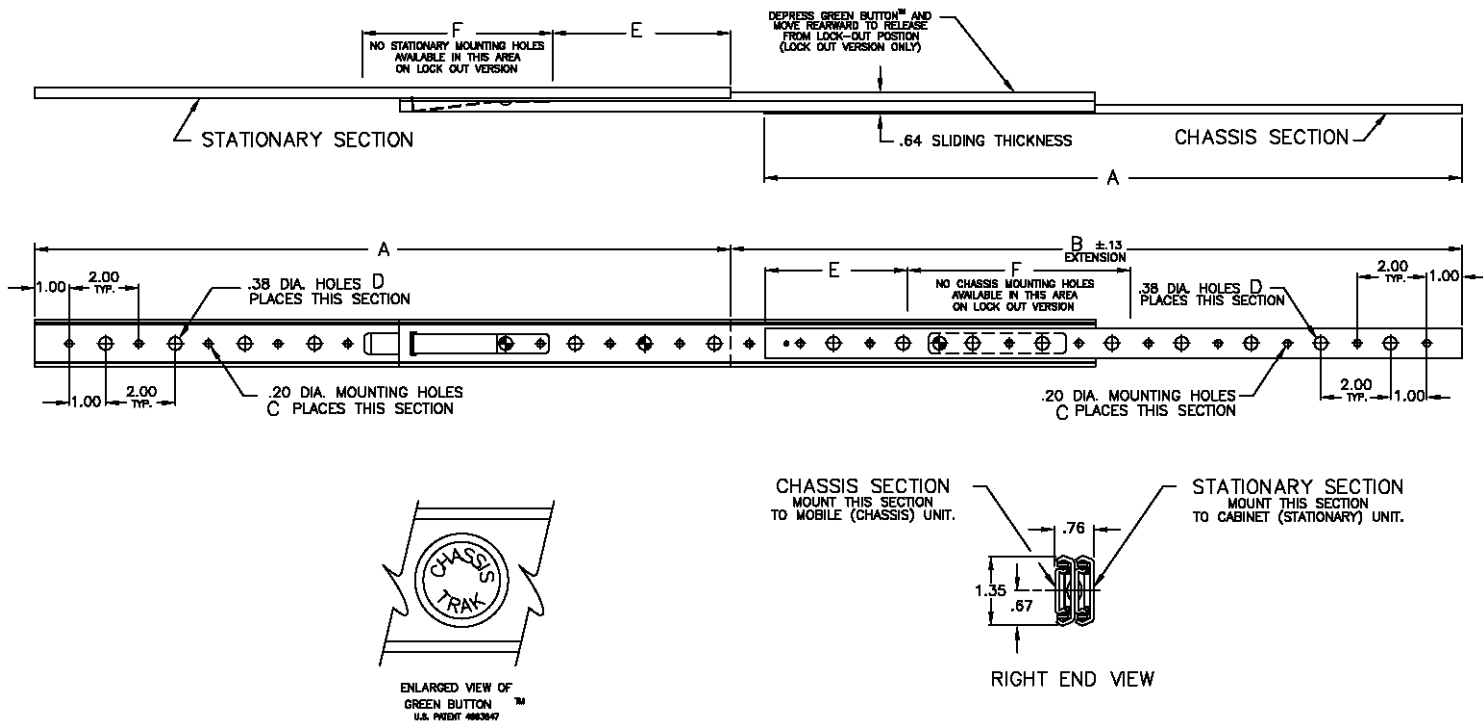

TO ORDER, SPECIFY

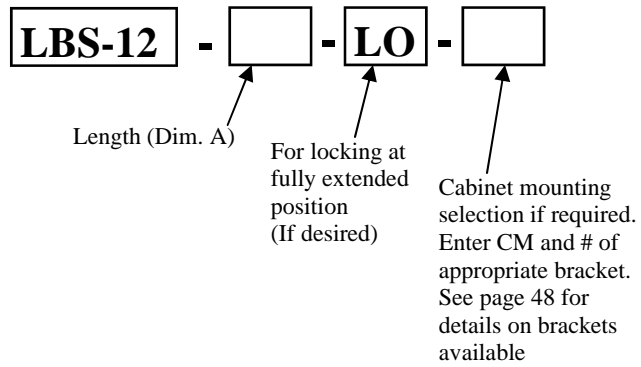

Notes

- LBS-12 consists of one set of two non-handed slides. Optional lock-out feature is available.
- All slides are supplied with special (.094" max. head height) #8-32x3/8 Phillips pan head screws and self-locking nuts for mounting one set of slides. Use only these special screws when mounting through slide member to prevent internal damage to ball retainer. If mounting to cabinet rails, see cabinet mounting section for ball bearing slides.
- LBS-12 does not disconnect.
- Slide members are made from 14 gauge (.074) work hardened cold rolled steel.
- Finish: clear zinc commercial plating.
- Holes other than those shown may be in part at manufacture's option.
- Load capacity is based on one set of slides at full extension with load (center of gravity) centered between the slides and at midpoint of the slide (chassis section). Load capacities have a 100% (static load) safety factor at full extension. The slides will support more than the stated capacities but are not designed to be operated at capacities greater than those stated.
- Grease applied to ball bearing slides has a temperature range of -45°F to +350°F.
- Odd length slides available, contact factory for more information.
- Other non-standard options which are available include: special marking, special extensions, special finishes, lock-in and complete design changes per customer request. Contact factory as these options will require a special reference number to assure receipt of specified options.

Catalog Number	A	B	C	D	E	F	Load Capacity
LBS-12-10	10.00	11.00	5	4	1.50	3.00	180 LBS.
LBS-12-12	12.00	13.00	6	5	1.50	3.00	175 LBS.
LBS-12-14	14.00	15.00	7	6	1.50	5.00	170 LBS.
LBS-12-16	16.00	17.00	8	7	2.00	5.00	160 LBS.
LBS-12-18	18.00	19.00	9	8	2.00	7.00	150 LBS.
LBS-12-20	20.00	21.00	10	9	4.00	5.00	145 LBS.
LBS-12-22	22.00	23.00	11	10	4.00	7.00	130 LBS.
LBS-12-24	24.00	25.00	12	11	6.00	5.00	115 LBS.
LBS-12-26	26.00	27.00	13	12	6.00	7.00	105 LBS.
LBS-12-28	28.00	29.00	14	13	8.00	5.00	90 LBS.
LBS-12-30	30.00	31.00	15	14	8.00	7.00	75 LBS.

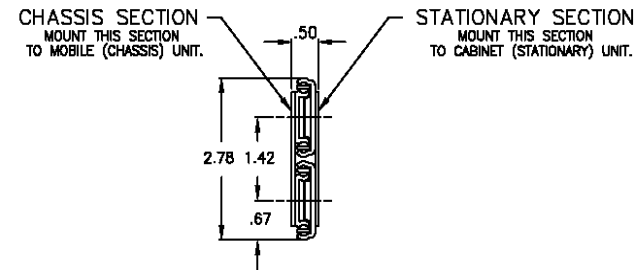
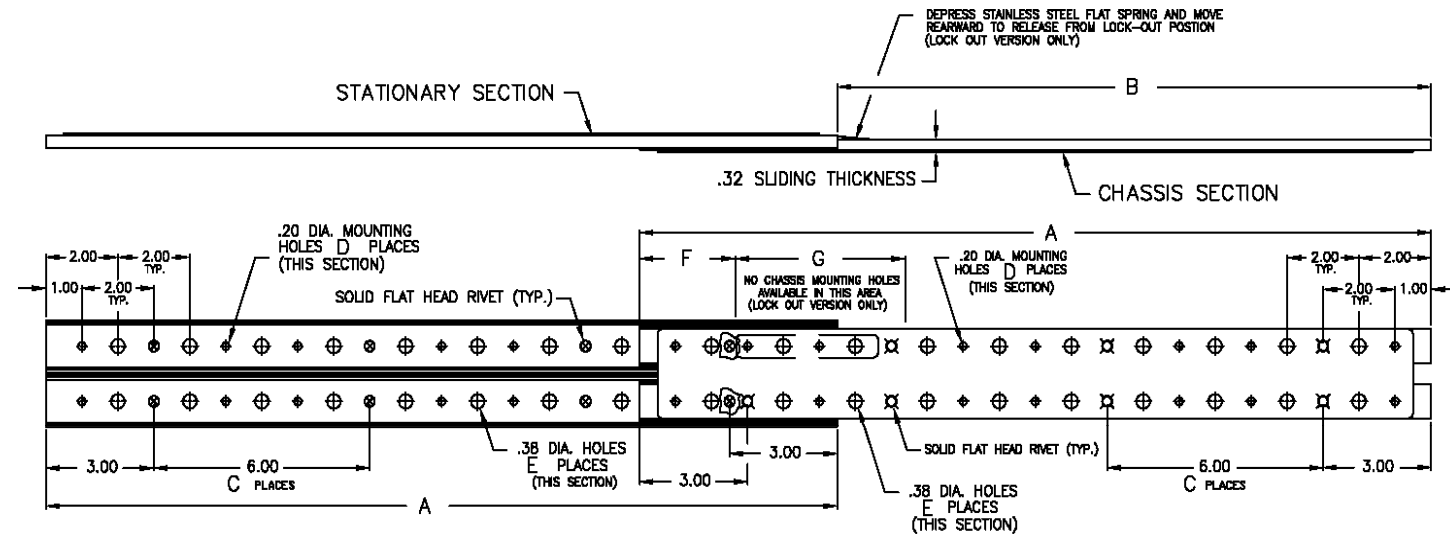

TO ORDER, SPECIFY

LBS-21 - - **LO** -

Length (Dim. A)

For locking at fully extended position (If desired)

Cabinet mounting selection if required. Enter CM and # of appropriate bracket. See page 48 for details on brackets available

Notes

- LBS-21 consists of one set of two non-handed slides. Optional lock-out feature is available.
- All slides are supplied with special (.094" max. head height) #8-32x3/8 Phillips pan head screws and self-locking nuts for mounting one set of slides. Use only these special screws when mounting through slide member to prevent internal damage to ball retainer. If mounting to cabinet rails, see cabinet mounting section for ball bearing slides.
- LBS-21 does not disconnect.
- Slide members are made from 14 gauge (.074) work hardened cold rolled steel.
- Finish: clear zinc commercial plating.
- Holes other than those shown may be in part at manufacture's option.
- Load capacity is based on one set of slides at full extension with load (center of gravity) centered between the slides and at midpoint of the slide (chassis section). Load capacities have a 100% (static load) safety factor at full extension. The slides will support more than the stated capacities but are not designed to be operated at capacities greater than those stated.
- Grease applied to ball bearing slides has a temperature range of -45°F to +350°F.
- Odd length slides available, contact factory for more information.
- Other non-standard options which are available include: special marking, special extensions, special finishes, lock-in and complete design changes per customer request. Contact factory as these options will require a special reference number to assure receipt of specified options.

Catalog Number	A	B	C	D	E	F	G	Load Capacity
LBS-21-10	10.00	7.50	OMIT	5	4	1.50	3.00	250 LBS.
LBS-21-12	12.00	9.00	OMIT	6	5	1.50	3.00	250 LBS.
LBS-21-14	14.00	10.50	OMIT	7	6	1.50	3.00	240 LBS.
LBS-21-16	16.00	12.00	1	8	7	1.50	5.00	230 LBS.
LBS-21-18	18.00	13.50	1	9	8	1.50	5.00	225 LBS.
LBS-21-20	20.00	15.00	1	10	9	1.50	5.00	220 LBS.
LBS-21-22	22.00	16.50	2	11	10	1.50	5.00	210 LBS.
LBS-21-24	24.00	18.00	2	12	11	1.50	7.00	200 LBS.
LBS-21-26	26.00	19.50	2	13	12	1.50	7.00	190 LBS.
LBS-21-28	28.00	21.00	3	14	13	3.50	5.00	180 LBS.
LBS-21-30	30.00	22.50	3	15	14	3.50	5.00	160 LBS.

LBS-22



Heavy Duty, Full Extension Ball Bearing Slide

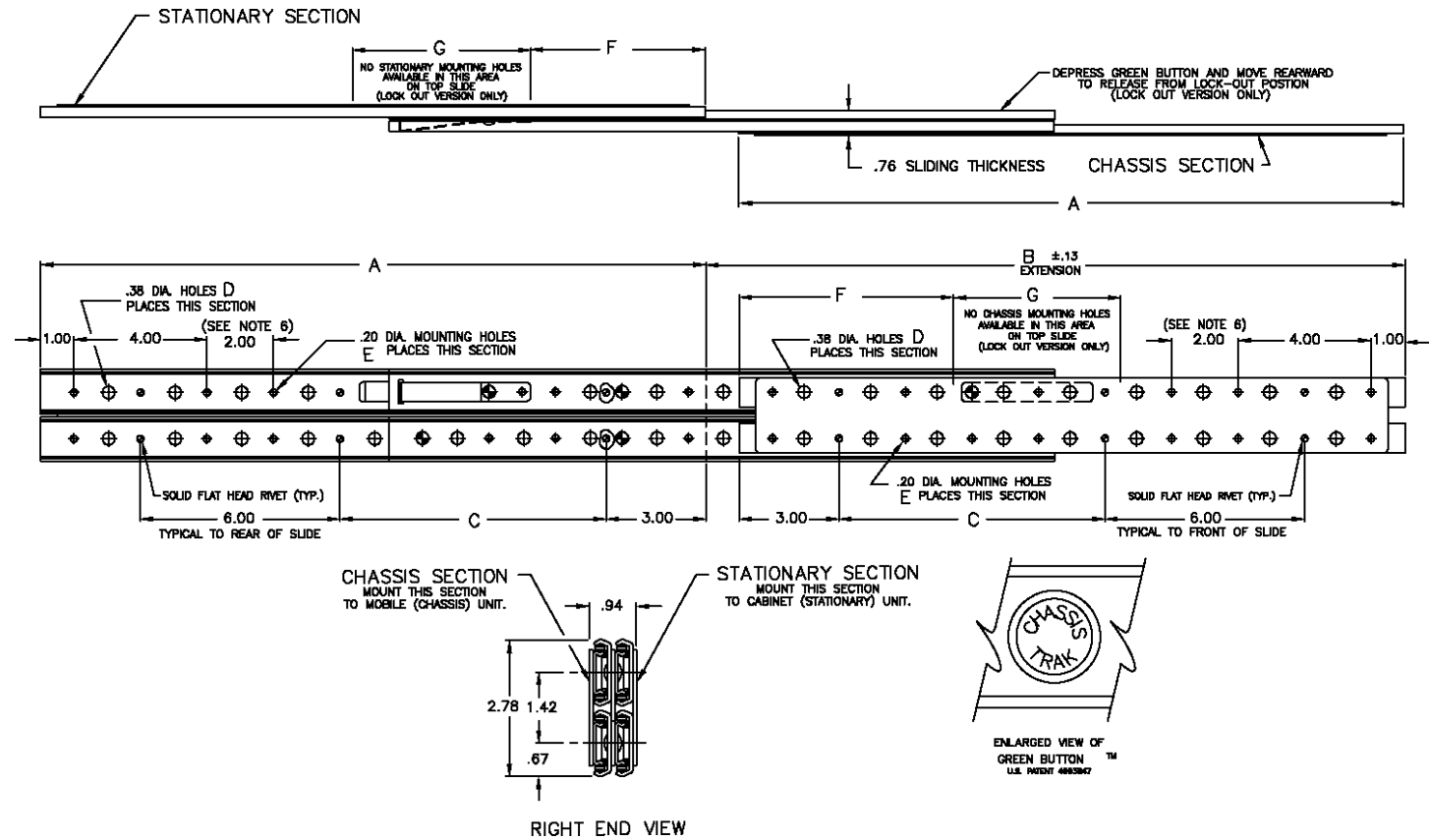

TO ORDER, SPECIFY

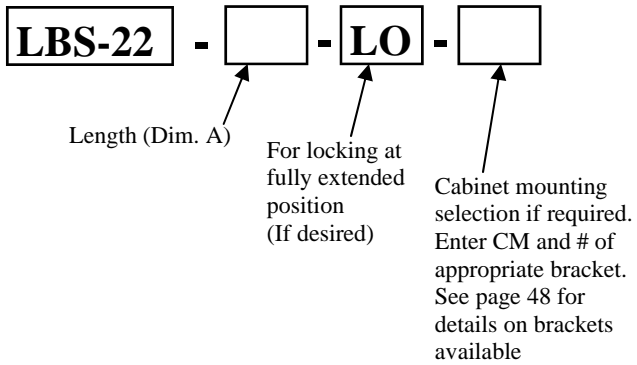

Notes

- LBS-22 consists of one set of two non-handed slides. Optional lock-out feature is available.
- All slides are supplied with special (.094" max. head height) #8-32x3/8 Phillips pan head screws and self-locking nuts for mounting one set of slides. Use only these special screws when mounting through slide member to prevent internal damage to ball retainer. If mounting to cabinet rails, see cabinet mounting section for ball bearing slides.
- LBS-22 does not disconnect.
- Slide members are made from 14 gauge (.074) work hardened cold rolled steel.
- Finish: clear zinc commercial plating.
- Typical mounting hole dimension except where replaced with solid flat head rivets.
- Holes other than those shown may be in part at manufacture's option.
- Load capacity is based on one set of slides at full extension with load (center of gravity) centered between the slides and at midpoint of the slide (chassis section). Load capacities have a 100% (static load) safety factor at full extension. The slides will support more than the stated capacities but are not designed to be operated at capacities greater than those stated.
- Grease applied to ball bearing slides has a temperature range of -45°F to +350°F.
- Odd length slides available, contact factory for more information.
- Other non-standard options which are available include: special marking, special extensions, special finishes, lock-in and complete design changes per customer request. Contact factory as these options will require a special reference number to assure receipt of specified options.

Catalog Number	A	B	C	D	E	F	G	Load Capacity
LBS-22-10	10.00	11.00	4.00	8	6	1.50	3.00	605 LBS.
LBS-22-12	12.00	13.00	6.00	10	8	1.50	5.00	600 LBS.
LBS-22-14	14.00	15.00	8.00	12	10	1.50	7.00	590 LBS.
LBS-22-16	16.00	17.00	4.00	14	10	3.50	5.00	570 LBS.
LBS-22-18	18.00	19.00	6.00	16	12	3.50	7.00	550 LBS.
LBS-22-20	20.00	21.00	8.00	18	14	5.50	5.00	530 LBS.
LBS-22-22	22.00	23.00	4.00	20	14	5.50	7.00	505 LBS.
LBS-22-24	24.00	25.00	6.00	22	16	7.50	5.00	475 LBS.
LBS-22-26	26.00	27.00	8.00	24	18	7.50	7.00	440 LBS.
LBS-22-28	28.00	29.00	4.00	26	18	9.50	5.00	400 LBS.
LBS-22-30	30.00	31.00	6.00	28	20	9.50	7.00	360 LBS.

Extra Heavy Duty, Full Extension Ball Bearing Slide

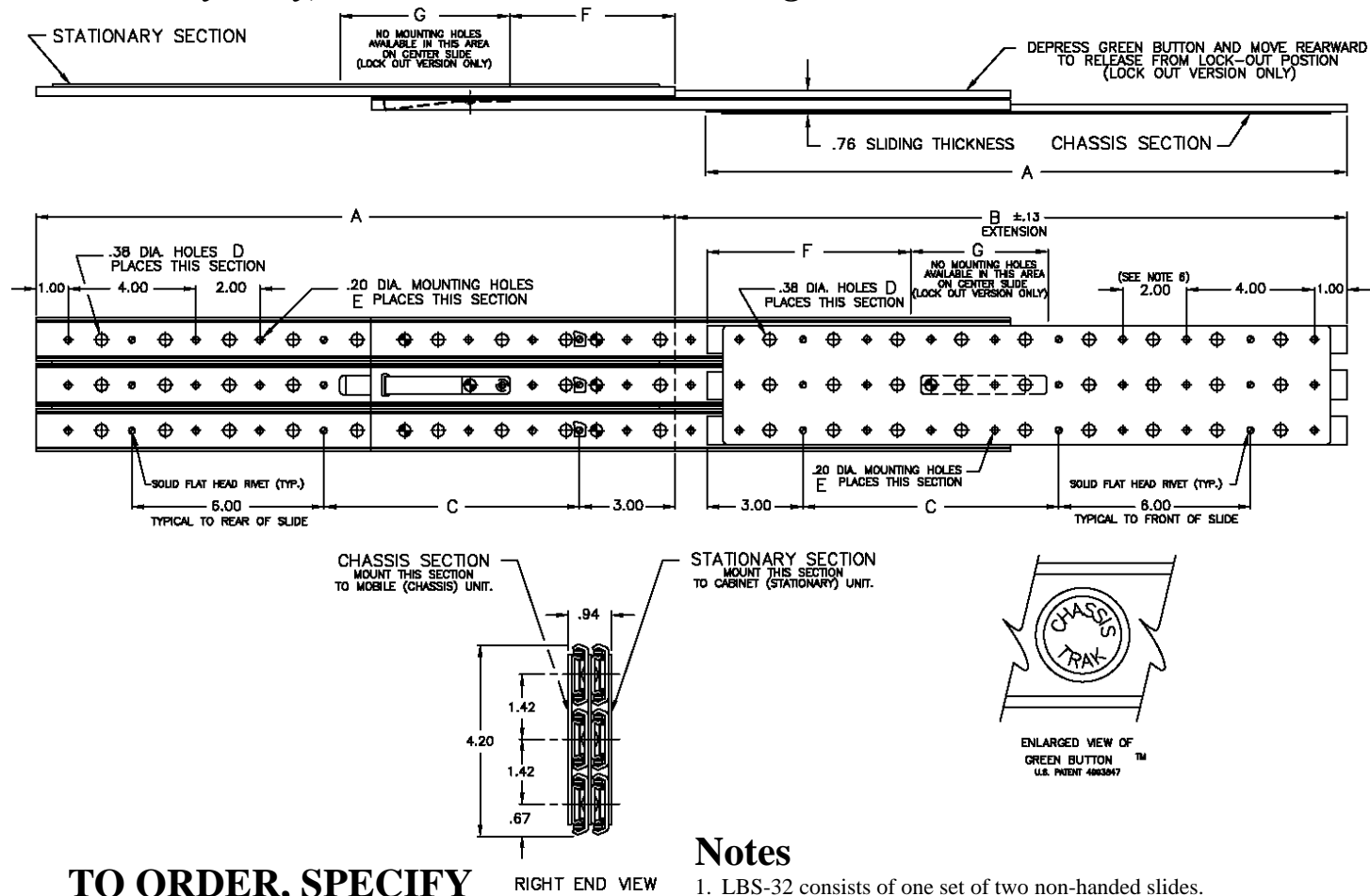

TO ORDER, SPECIFY

LBS-32 - - **LO** -

Length (Dim. A)

For locking at fully extended position (If desired)

Cabinet mounting selection if required. Enter CM and # of appropriate bracket. See page 48 for details on brackets available

Notes

- LBS-32 consists of one set of two non-handed slides. Optional lock-out feature is available.
- All slides are supplied with special (.094" max. head height) #8-32x3/8 Phillips pan head screws and self-locking nuts for mounting one set of slides. Use only these special screws when mounting through slide member to prevent internal damage to ball retainer. If mounting to cabinet rails, see cabinet mounting section for ball bearing slides.
- LBS-32 does not disconnect.
- Slide members are made from 14 gauge (.074) work hardened cold rolled steel.
- Finish: clear zinc commercial plating.
- Typical mounting hole dimension except where replaced with solid flat head rivets.
- Holes other than those shown may be in part at manufacture's option.
- Load capacity is based on one set of slides at full extension with load (center of gravity) centered between the slides and at midpoint of the slide (chassis section). Load capacities have a 100% (static load) safety factor at full extension. The slides will support more than the stated capacities but are not designed to be operated at capacities greater than those stated.
- Grease applied to ball bearing slides has a temperature range of -45°F to +350°F.
- Odd length slides available, contact factory for more information.
- Other non-standard options which are available include: special marking, special extensions, special finishes, lock-in and complete design changes per customer request. Contact factory as these options will require a special reference number to assure receipt of specified options.

Catalog Number	A	B	C	D	E	F	G	Load Capacity
LBS-32-10	10.00	11.00	4.00	12	9	1.50	5.00	930 LBS.
LBS-32-12	12.00	13.00	6.00	15	12	1.50	5.00	925 LBS.
LBS-32-14	14.00	15.00	8.00	18	15	1.50	7.00	910 LBS.
LBS-32-16	16.00	17.00	4.00	21	15	3.50	5.00	885 LBS.
LBS-32-18	18.00	19.00	6.00	24	18	3.50	7.00	850 LBS.
LBS-32-20	20.00	21.00	8.00	27	21	5.50	5.00	820 LBS.
LBS-32-22	22.00	23.00	4.00	30	21	5.50	7.00	780 LBS.
LBS-32-24	24.00	25.00	6.00	33	24	7.50	5.00	730 LBS.
LBS-32-26	26.00	27.00	8.00	36	27	7.50	7.00	670 LBS.
LBS-32-28	28.00	29.00	4.00	39	27	9.50	5.00	600 LBS.
LBS-32-30	30.00	31.00	6.00	42	30	9.50	7.00	510 LBS.

Over and Under Full Extension Ball Bearing Slide

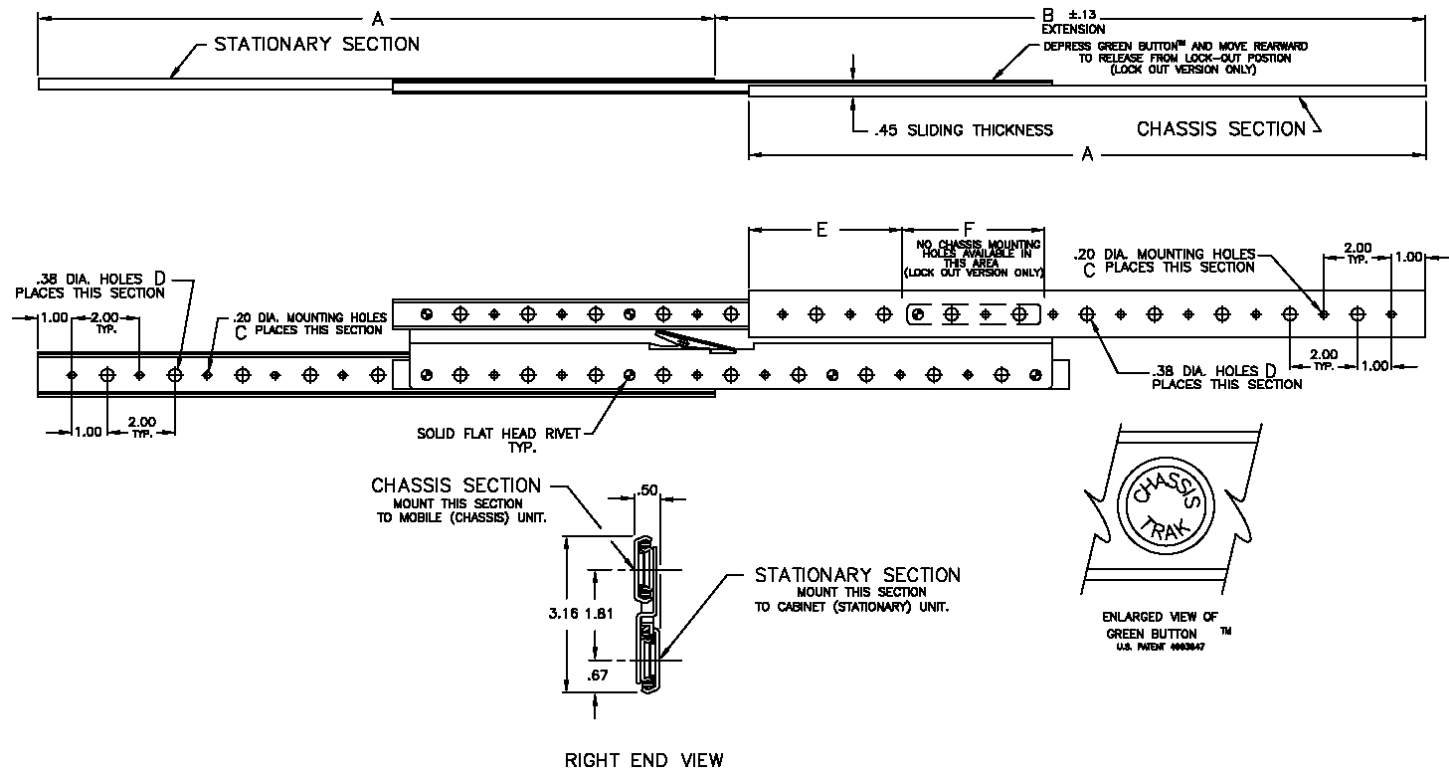

TO ORDER, SPECIFY

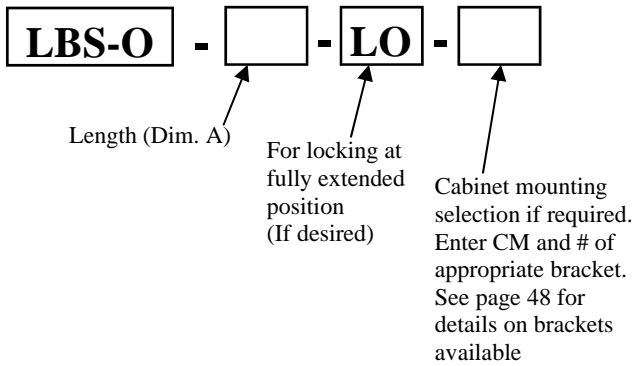

Notes

- LBS-O consists of one right hand and one left hand slide pair. Optional lock-out feature is available.
- All slides are supplied with special (.094" max. head height) #8-32x3/8 Phillips pan head screws and self-locking nuts for mounting one set of slides. Use only these special screws when mounting through slide member to prevent internal damage to ball retainer. If mounting to cabinet rails, see cabinet mounting section for ball bearing slides.
- LBS-O does not disconnect.
- Slide members are made from 14 gauge (.074) work hardened cold rolled steel.
- Finish: clear zinc commercial plating.
- Holes other than those shown may be in part at manufacture's option.
- Load capacity is based on one set of slides at full extension with load (center of gravity) centered between the slides and at midpoint of the slide (chassis section). Load capacities have a 100% (static load) safety factor at full extension. The slides will support more than the stated capacities but are not designed to be operated at capacities greater than those stated.
- Grease applied to ball bearing slides has a temperature range of -45°F to +350°F.
- Odd length slides available, contact factory for more information.
- Other non-standard options which are available include: special marking, special extensions, special finishes, lock-in and complete design changes per customer request. Contact factory as these options will require a special reference number to assure receipt of specified options.

Catalog Number	A	B	C	D	E	F	Load Capacity
LBS-O-10	10.00	11.00	5	4	OMIT	OMIT	180 LBS.
LBS-O-12	12.00	13.00	6	5	1.50	4.50	175 LBS.
LBS-O-14	14.00	15.00	7	6	1.50	4.50	170 LBS.
LBS-O-16	16.00	17.00	8	7	2.50	4.00	160 LBS.
LBS-O-18	18.00	19.00	9	8	2.50	5.00	150 LBS.
LBS-O-20	20.00	21.00	10	9	4.50	4.00	145 LBS.
LBS-O-22	22.00	23.00	11	10	4.50	5.00	130 LBS.
LBS-O-24	24.00	25.00	12	11	6.50	4.00	115 LBS.
LBS-O-26	26.00	27.00	13	12	6.50	5.00	105 LBS.
LBS-O-28	28.00	29.00	14	13	8.50	4.00	90 LBS.
LBS-O-30	30.00	31.00	15	14	8.50	5.00	75 LBS.

CLB-203 Slide



(3/4) Extension Slide With Quick Disconnect

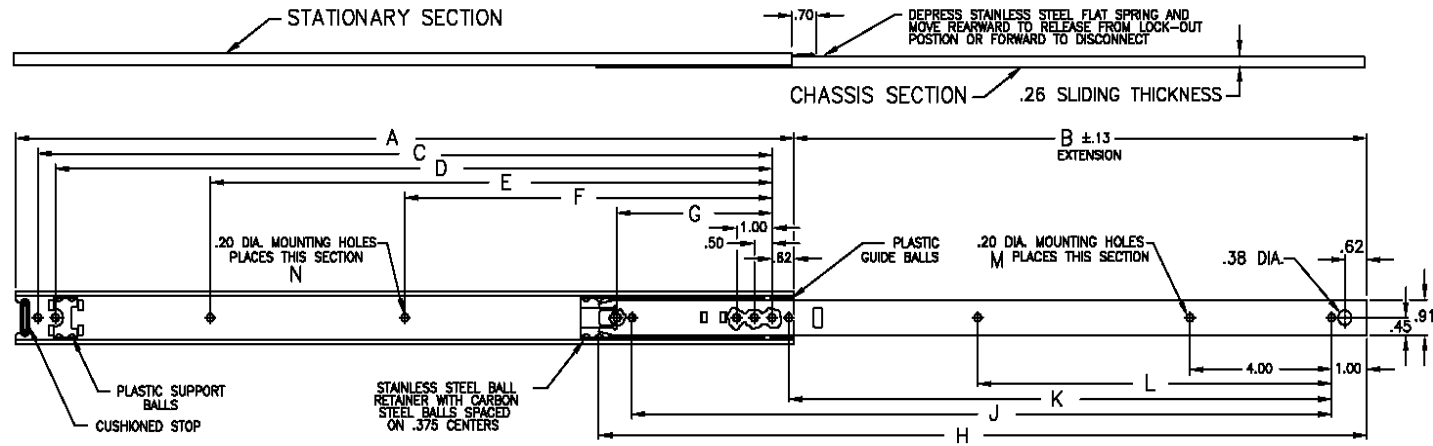

TO ORDER, SPECIFY

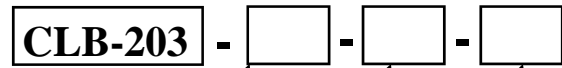

Length (Dim. A)

AR - Automatic Release (non-locking)

Cabinet mounting selection if required. Enter CM and # of appropriate bracket. See page 48 for details on brackets available

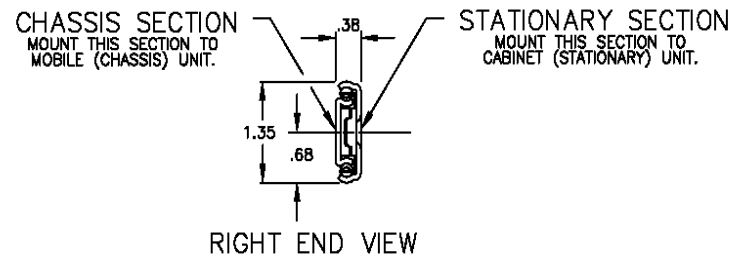

Notes

- CLB-203 consists of one set of two non-handed slides.
- All slides are supplied with special (.094" max. head height) #8-32x3/8 Phillips pan head screws and self-locking nuts for mounting one set of slides. Use only these special screws when mounting through slide member to prevent internal damage to ball retainer. If mounting to cabinet rails, see cabinet mounting section for ball bearing slides.
- CLB-203 has a front disconnect feature and locks at full extension. For non-locking, see "order" chart.
- Slide members are made from 14 gauge (.074) work hardened cold rolled steel.
- Finish: clear zinc commercial plating.
- Holes other than those shown may be in part at manufacture's option.
- Load capacity is based on one set of slides at full extension with load (center of gravity) centered between the slides and at midpoint of the slide (chassis section). Load capacities have a 100% (static load) safety factor at full extension. The slides will support more than the stated capacities but are not designed to be operated at capacities greater than those stated.
- Grease applied to ball bearing slides has a temperature range of -45°F to +350°F, however, due to the use of plastic guide and support balls, the slide is designed for applications not exceeding 150°F ambient temperature.
- Odd length slides available, contact factory for more information.
- Other non-standard options which are available include: special marking, special extensions, special finishes, lock-in and complete design changes per customer request. Contact factory as these options will require a special reference number to assure receipt of specified options.

Catalog Number	A	B	C	D	E	F	G	H	J	K	L	M	N	Load Capacity
CLB-203-10	10.0	7.0	8.75	8.25	3.875	OMIT	OMIT	9.62	8.0	OMIT	OMIT	3	6	145 LBS.
CLB-203-12	12.0	9.0	10.75	10.25	5.875	OMIT	4.375	11.62	10.0	6.0	OMIT	4	7	140 LBS.
CLB-203-14	14.0	11.0	12.75	12.25	7.875	OMIT	4.375	13.62	12.0	8.0	OMIT	4	7	130 LBS.
CLB-203-16	16.0	12.0	14.75	14.25	9.875	OMIT	4.375	15.62	14.0	10.0	OMIT	4	7	120 LBS.
CLB-203-18	18.0	13.0	16.75	16.25	11.875	8.365	4.375	17.62	16.0	OMIT	8.0	4	8	110 LBS.
CLB-203-20	20.0	15.0	18.75	18.25	13.875	9.375	4.375	19.62	18.0	OMIT	9.0	4	8	95 LBS.
CLB-203-22	22.0	16.0	20.75	20.25	15.875	10.375	4.375	21.62	20.0	16.0	10.0	5	8	85 LBS.
CLB-203-24	24.0	17.0	22.75	22.25	17.875	11.375	4.375	23.62	22.0	18.0	11.0	5	8	80 LBS.
CLB-203-26	26.0	19.0	24.75	24.25	19.875	12.375	4.375	25.62	24.0	20.0	12.0	5	8	70 LBS.
CLB-203-28	28.0	20.0	26.75	26.25	21.875	13.375	4.375	27.62	26.0	22.0	13.0	5	8	60 LBS.
CLB-203-30	30.0	21.0	28.75	28.25	23.875	14.375	4.375	29.62	28.0	24.0	14.0	5	8	50 LBS.

CLB-223 Slide



Heavy Duty, (3/4) Extension Quick Disconnect Slide

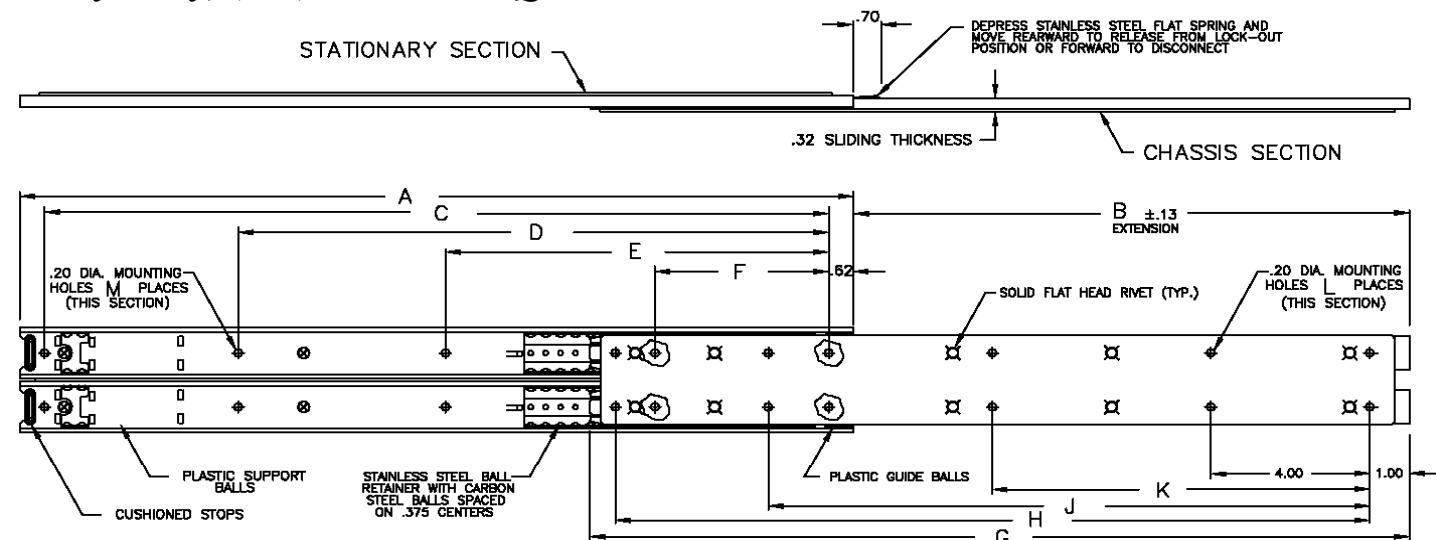

TO ORDER, SPECIFY

CLB-223 - [] - [] - []

Length (Dim. A)

AR - Automatic Release (non-locking)

Cabinet mounting selection if required. Enter CM and # of appropriate bracket. See page 48 for details on brackets available

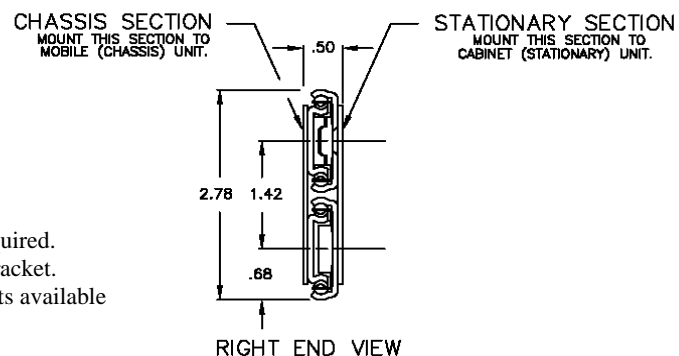

Notes

- CLB-223 consists of one right and one left hand slide (1 pair).
- All slides are supplied with special (.094" max. head height) #8-32x3/8 Phillips pan head screws and self-locking nuts for mounting one set of slides. Use only these special screws when mounting through slide member to prevent internal damage to ball retainer. If mounting to cabinet rails, see cabinet mounting section for ball bearing slides.
- CLB-223 has a front disconnect feature and locks at full extension. For non-locking, see "order" chart.
- Slide members are made from 14 gauge (.074) work hardened cold rolled steel.
- Finish: clear zinc commercial plating.
- Holes other than those shown may be in part at manufacture's option.
- Load capacity is based on one set of slides at full extension with load (center of gravity) centered between the slides and at midpoint of the slide (chassis section). Load capacities have a 100% (static load) safety factor at full extension. The slides will support more than the stated capacities but are not designed to be operated at capacities greater than those stated.
- Grease applied to ball bearing slides has a temperature range of -45°F to +350°F, however, due to the use of plastic guide and support balls, the slide is designed for applications not exceeding 150°F ambient temperature.
- Odd length slides available, contact factory for more information.
- Other non-standard options which are available include: special marking, special extensions, special finishes, lock-in and complete design changes per customer request. Contact factory as these options will require a special reference number to assure receipt of specified options.

Catalog Number	A	B	C	D	E	F	G	H	J	K	L	M	Load Capacity
CLB-223-10	10.0	7.0	8.75	3.875	OMIT	OMIT	9.62	8.0	OMIT	OMIT	6	10	250 LBS.
CLB-223-12	12.0	9.0	10.75	5.875	OMIT	4.375	11.62	10.0	6.0	OMIT	8	14	250 LBS.
CLB-223-14	14.0	11.0	12.75	7.875	OMIT	4.375	13.62	12.0	8.0	OMIT	8	14	240 LBS.
CLB-223-16	16.0	12.0	14.75	9.875	OMIT	4.375	15.62	14.0	10.0	OMIT	8	14	230 LBS.
CLB-223-18	18.0	13.0	16.75	11.875	8.375	4.375	17.62	16.0	OMIT	8.0	8	16	225 LBS.
CLB-223-20	20.0	15.0	18.75	13.875	9.375	4.375	19.62	18.0	OMIT	9.0	8	16	220 LBS.
CLB-223-22	22.0	16.0	20.75	15.875	10.375	4.375	21.62	20.0	16.0	10.0	10	16	210 LBS.
CLB-223-24	24.0	17.0	22.75	17.875	11.375	4.375	23.62	22.0	18.0	11.0	10	16	200 LBS.
CLB-223-26	26.0	19.0	24.75	19.875	12.375	4.375	25.62	24.0	20.0	12.0	10	16	190 LBS.
CLB-223-28	28.0	20.0	26.75	21.875	13.375	4.375	27.62	26.0	22.0	13.0	10	16	180 LBS.
CLB-223-30	30.0	21.0	28.75	23.875	14.375	4.375	29.62	28.0	24.0	14.0	10	16	160 LBS.

CLB-305 Slide



Full Extension, Quick Disconnect Ball Bearing Slide

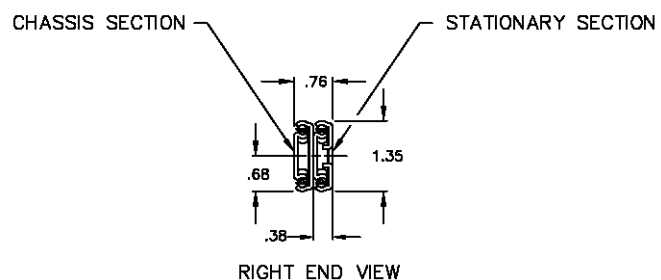
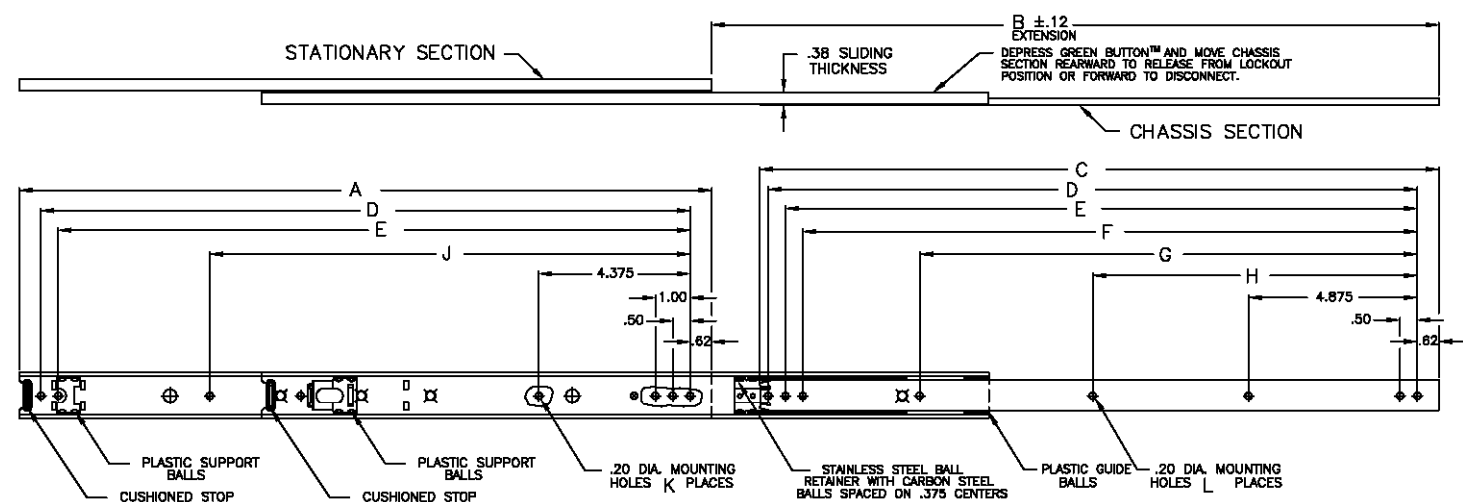

TO ORDER, SPECIFY

CLB-305 - [] - [] - []

- Length (Dim. A)
- AR - Automatic Release (non-locking)
- Cabinet mounting selection if required. Enter CM and # of appropriate bracket. See page 48 for details on brackets available

CLB-305 slide is designed to have .38 Sliding Thickness. See Note #5.

Notes

- CLB-305 consists of one set of two non-handed slides.
- All slides are supplied with special (.094" max. head height) #8-32x3/8 Phillips pan head screws and self-locking nuts for mounting one set of slides. Use only these special screws when mounting through slide member to prevent internal damage to ball retainer. If mounting to cabinet rails, see cabinet mounting section for ball bearing slides.
- CLB-305 has a front disconnect feature and locks at full extension. For non-locking, see "order" chart.
- Slide members are made from 14 gauge (.074) work hardened cold rolled steel.
- Slide is designed to allow stationary section to be mounted between the cabinet mounting rails to take advantage of the .38" sliding thickness. Recommended slide length is 1.0" less than the rail setting.**
- Finish: clear zinc commercial plating.
- Holes other than those shown may be in part at manufacture's option.
- Load capacity is based on one set of slides at full extension with load (center of gravity) centered between the slides and at midpoint of the slide (chassis section). Load capacities have a 100% (static load) safety factor at full extension. The slides will support more than the stated capacities but are not designed to be operated at capacities greater than those stated.
- Grease applied to ball bearing slides has a temperature range of -45°F to +350°F, however, due to the use of plastic guide and support balls, the slide is designed for applications not exceeding 150°F ambient temperature.
- Odd length slides available, contact factory for more information.
- Other non-standard options which are available include: special marking, special extensions, special finishes, lock-in and complete design changes per customer request. Contact factory as these options will require a special reference number to assure receipt of specified options.

Catalog Number	A	B	C	D	E	F	G	H	J	K	L	Load Capacity
CLB-305-12	12.0	12.6	11.62	10.75	10.25	OMIT	OMIT	OMIT	OMIT	6	5	140 LBS.
CLB-305-14	14.0	15.0	13.62	12.75	12.25	11.75	OMIT	OMIT	OMIT	6	6	135 LBS.
CLB-305-16	16.0	17.0	15.62	14.75	14.25	13.75	OMIT	OMIT	9.875	7	6	125 LBS.
CLB-305-18	18.0	19.0	17.62	16.75	16.25	15.75	OMIT	8.375	11.875	7	7	120 LBS.
CLB-305-20	20.0	21.0	19.62	18.75	18.25	17.75	14.375	9.375	13.875	7	8	110 LBS.
CLB-305-22	22.0	23.0	21.62	20.75	20.25	19.75	16.375	10.375	15.875	7	8	100 LBS.
CLB-305-24	24.0	25.0	23.62	22.75	22.25	21.75	18.375	11.375	17.875	7	8	95 LBS.
CLB-305-26	26.0	27.0	25.62	24.75	24.25	23.75	20.375	12.375	19.875	7	8	90 LBS.
CLB-305-28	28.0	29.0	27.62	26.75	26.25	25.75	22.375	13.375	21.875	7	8	80 LBS.
CLB-305-30	30.0	31.0	29.62	28.75	28.25	27.75	24.375	14.375	23.875	7	8	75 LBS.

CLB-307 Slide



Full Extension, Quick Disconnect Ball Bearing Slide

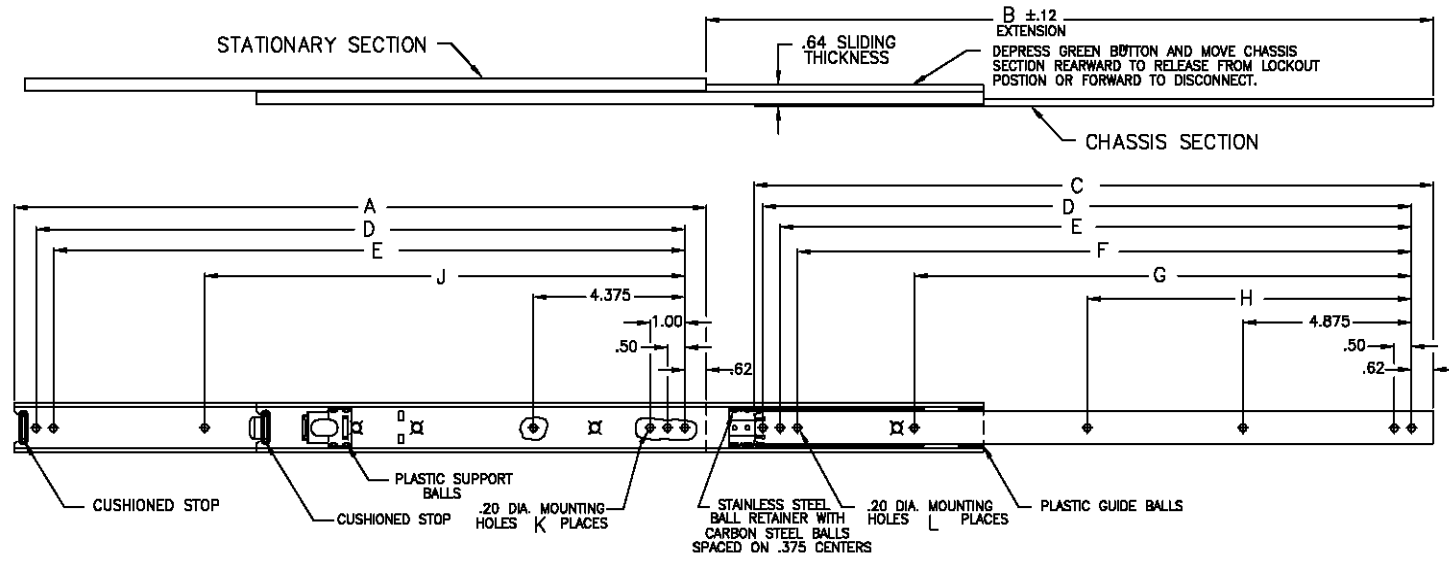

TO ORDER, SPECIFY

CLB-307 - - -

Length (Dim. A)

AR - Automatic Release (non-locking)

Cabinet mounting selection if required. Enter CM and # of appropriate bracket. See page 48 for details on brackets available

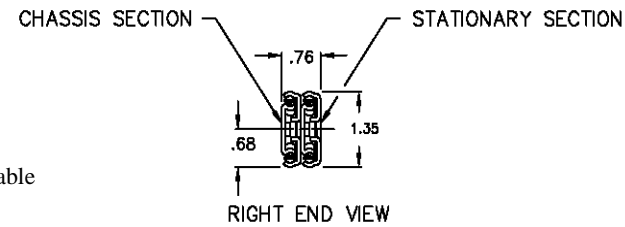

Notes

- CLB-307 consists of one set of two non-handed slides.
- All slides are supplied with special (.094" max. head height) #8-32x3/8 Phillips pan head screws and self-locking nuts for mounting one set of slides. Use only these special screws when mounting through slide member to prevent internal damage to ball retainer. If mounting to cabinet rails, see cabinet mounting section for ball bearing slides.
- CLB-307 has a front disconnect feature and locks at full extension. For non-locking, see "order" chart.
- Slide members are made from 14 gauge (.074) work hardened cold rolled steel.
- Finish: clear zinc commercial plating.
- Holes other than those shown may be in part at manufacture's option.
- Load capacity is based on one set of slides at full extension with load (center of gravity) centered between the slides and at midpoint of the slide (chassis section). Load capacities have a 100% (static load) safety factor at full extension. The slides will support more than the stated capacities but are not designed to be operated at capacities greater than those stated.
- Grease applied to ball bearing slides has a temperature range of -45°F to +350°F, however, due to the use of plastic guide and support balls, the slide is designed for applications not exceeding 150°F ambient temperature.
- Odd length slides available, contact factory for more information.
- Other non-standard options which are available include: special marking, special extensions, special finishes, lock-in and complete design changes per customer request. Contact factory as these options will require a special reference number to assure receipt of specified options.

Catalog Number	A	B	C	D	E	F	G	H	J	K	L	Load Capacity
CLB-307-12	12.0	13.0	11.62	10.75	10.25	OMIT	OMIT	OMIT	OMIT	5	5	175 LBS.
CLB-307-14	14.0	15.0	13.62	12.75	12.25	11.75	OMIT	OMIT	OMIT	5	6	170 LBS.
CLB-307-16	16.0	17.0	15.62	14.75	14.25	13.75	OMIT	OMIT	9.875	7	6	160 LBS.
CLB-307-18	18.0	19.0	17.62	16.75	16.25	15.75	OMIT	8.375	11.875	7	7	150 LBS.
CLB-307-20	20.0	21.0	19.62	18.75	18.25	17.75	14.375	9.375	13.875	7	8	145 LBS.
CLB-307-22	22.0	23.0	21.62	20.75	20.25	19.75	16.375	10.375	15.875	7	8	130 LBS.
CLB-307-24	24.0	25.0	23.62	22.75	22.25	21.75	18.375	11.375	17.875	7	8	115 LBS.
CLB-307-26	26.0	27.0	25.62	24.75	24.25	23.75	20.375	12.375	19.875	7	8	105 LBS.
CLB-307-28	28.0	29.0	27.62	26.75	26.25	25.75	22.375	13.375	21.875	7	8	90 LBS.
CLB-307-30	30.0	31.0	29.62	28.75	28.25	27.75	24.375	14.375	23.875	7	8	75 LBS.

CLB-315 Slide



Full Extension, Quick Disconnect Ball Bearing Slide

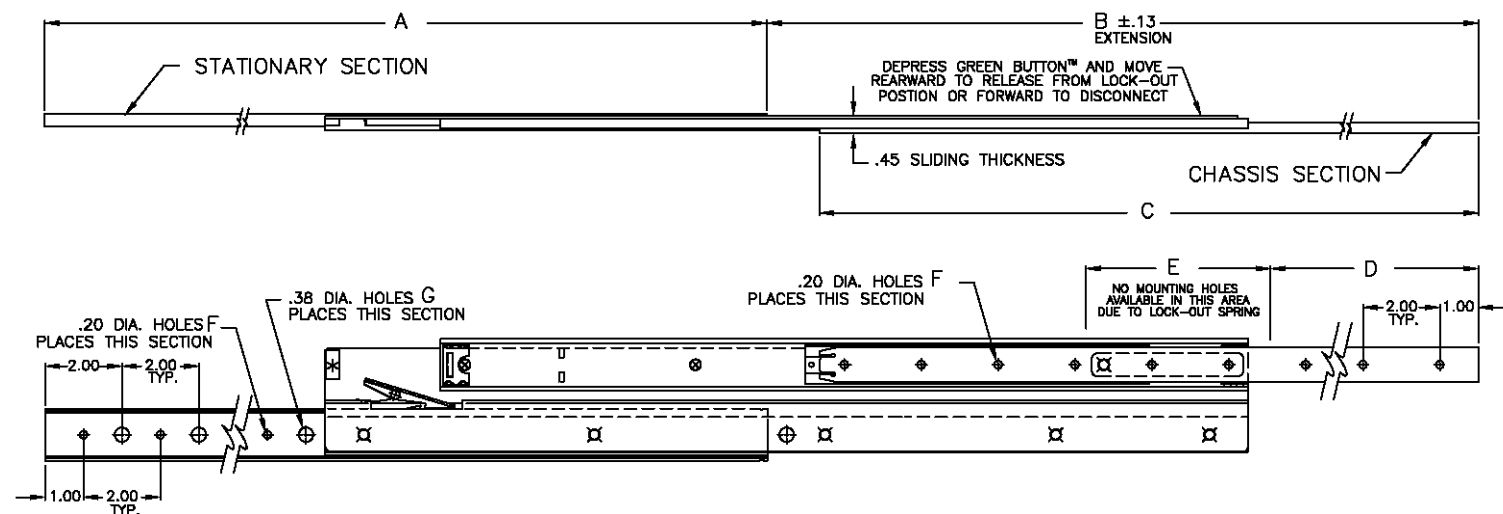

TO ORDER, SPECIFY

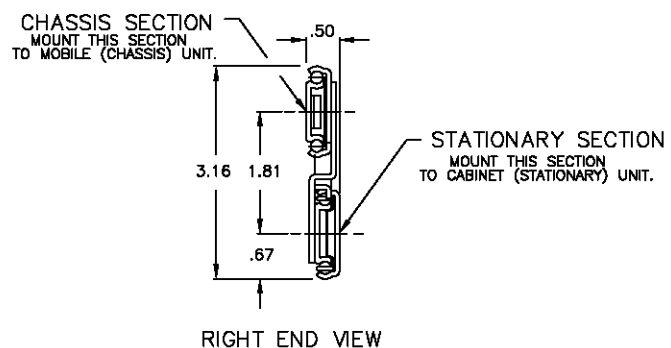
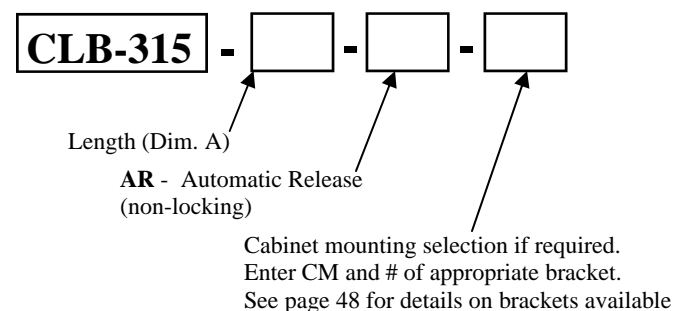

Notes

- CLB-315 consists of one right hand and one left hand slide (1 pair).
- All slides are supplied with special (.094" max. head height) #8-32x3/8 Phillips pan head screws and self-locking nuts for mounting one set of slides. Use only these special screws when mounting through slide member to prevent internal damage to ball retainer. If mounting to cabinet rails, see cabinet mounting section for ball bearing slides.
- CLB-315 has a front disconnect feature and locks at full extension. For non-locking, see "order" chart.
- Slide members are made from 14 gauge (.074) work hardened cold rolled steel.
- Finish: clear zinc commercial plating.
- Holes other than those shown may be in part at manufacture's option.
- Load capacity is based on one set of slides at full extension with load (center of gravity) centered between the slides and at midpoint of the slide (chassis section). Load capacities have a 100% (static load) safety factor at full extension. The slides will support more than the stated capacities but are not designed to be operated at capacities greater than those stated.
- Grease applied to ball bearing slides has a temperature range of -45°F to +350°F, however, due to the use of plastic guide and support balls, the slide is designed for applications not exceeding 150°F ambient temperature.
- Odd length slides available, contact factory for more information.
- Other non-standard options which are available include: special marking, special extensions, special finishes, lock-in and complete design changes per customer request. Contact factory as these options will require a special reference number to assure receipt of specified options.

Catalog Number	A	B	C	D	E	F	G	Load Capacity
CLB-315-14	14.0	15.0	13.63	7.63	4.50	7	6	170 LBS.
CLB-315-16	16.0	17.0	15.63	8.63	4.00	8	7	160 LBS.
CLB-315-18	18.0	19.0	17.63	9.63	5.00	9	8	150 LBS.
CLB-315-20	20.0	21.0	19.63	10.63	4.00	10	9	145 LBS.
CLB-315-22	22.0	23.0	21.63	11.63	5.00	11	10	130 LBS.
CLB-315-24	24.0	25.0	23.63	12.63	4.00	12	11	115 LBS.
CLB-315-26	26.0	27.0	25.63	13.63	5.00	13	12	105 LBS.
CLB-315-28	28.0	29.0	27.63	14.63	4.00	14	13	90 LBS.
CLB-315-30	30.0	31.0	29.63	15.63	5.00	15	14	75 LBS.

Ball Bearing Slide Mounting Brackets



Matrix For Ball Bearing Slides & Appropriate Cabinet Mounting Brackets with Maximum Extension												
	CM1/Ext.	CM2/Ext.	CM3/Ext.	CM4/Ext.	CM5/Ext.	CM6/Ext.	CM7/Ext.	CM8/Ext.	CM9/Ext.	CM11/Ext.	CM12/Ext.	CM14/Ext.
LBS-11	●/1.00	●/1.00	●/3.16	●/6.16	●/1.00	●/2.40						●/6.16
LBS-12	●/1.00	●/1.00	●/3.16	●/6.16	●/1.00	●/2.40						●/6.16
LBS-O	●/1.00	●/1.00	●/3.16	●/6.16	●/1.00	●/2.40						●/6.16
LBS-21									●/1.45			
LBS-22									●/1.45			
LBS-32											●/1.45	
CLB-203	●/1.36	●/1.36	●/3.53	●/6.53	●/1.36	●/2.77						●/6.16
CLB-223										●/1.19		
CLB-305							●/1.77	●/1.77				
CLB-307	●/1.36	●/1.36	●/3.53	●/6.53	●/1.36	●/2.77						●/6.16
CLB-315	●/1.00	●/1.00	●/3.16	●/6.16	●/1.00	●/2.40						●/6.16

CM 1

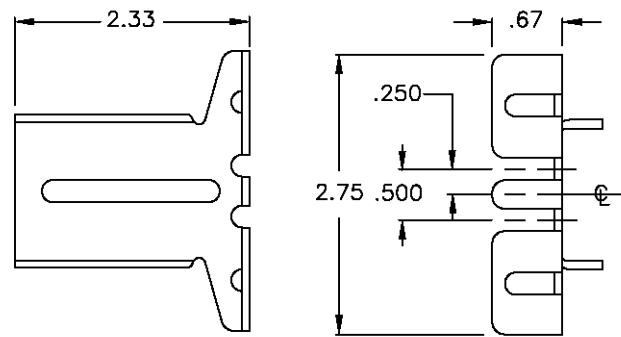

CM 2

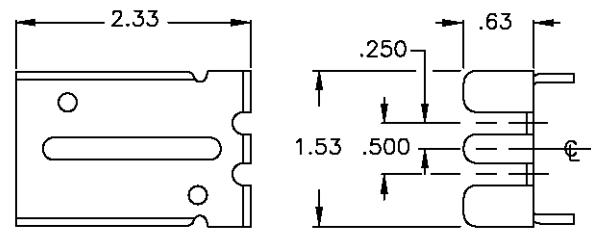

CM 3

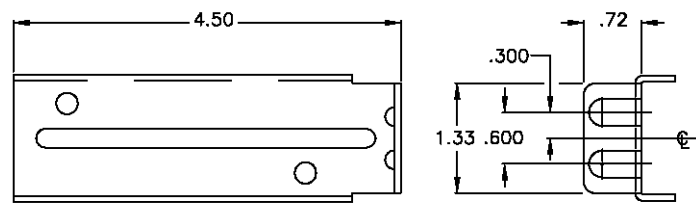

CM 4

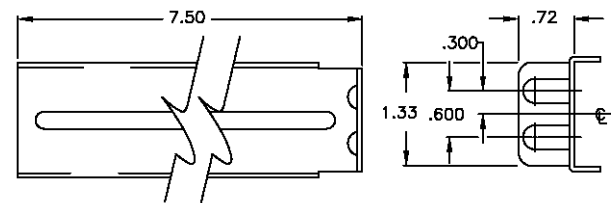

CM 5

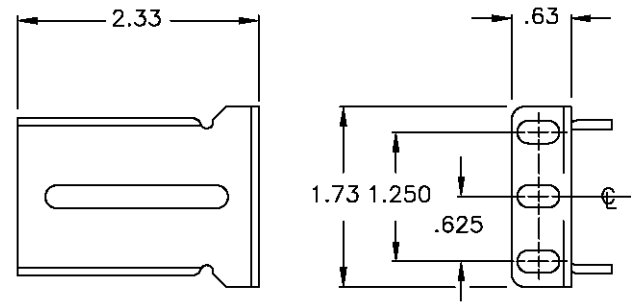

CM 6

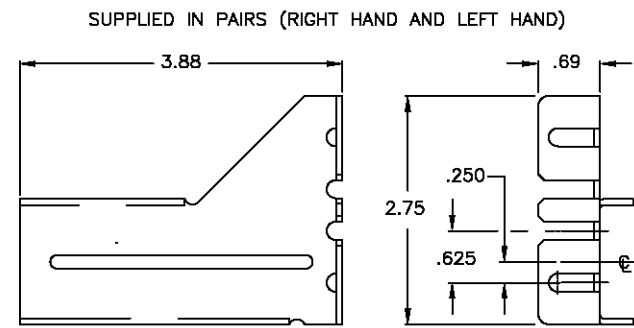

CM 7

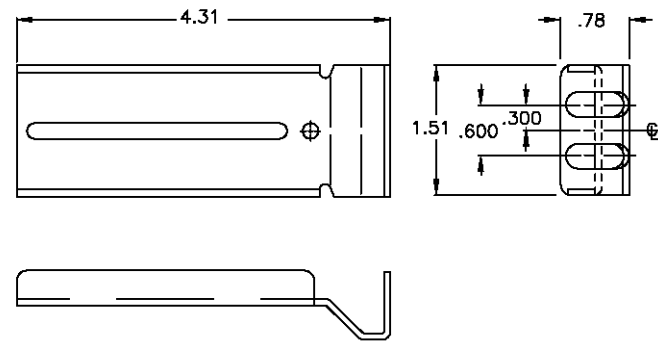

CM 8

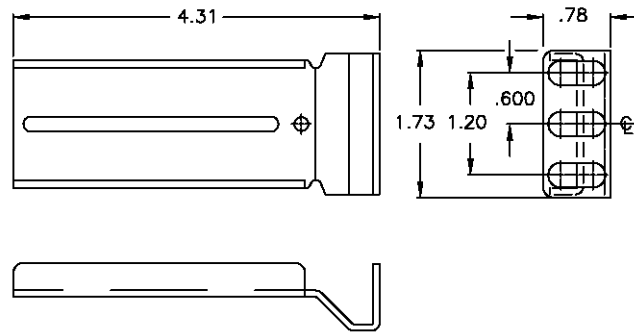

CM 9

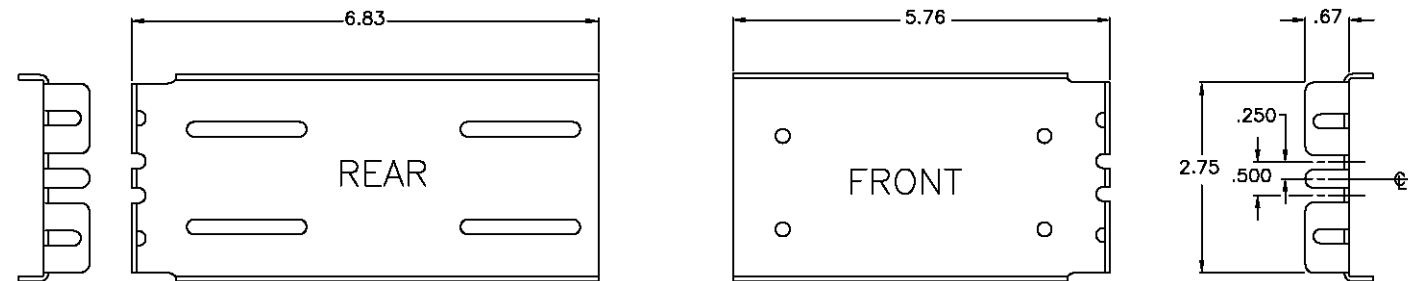

CM 11

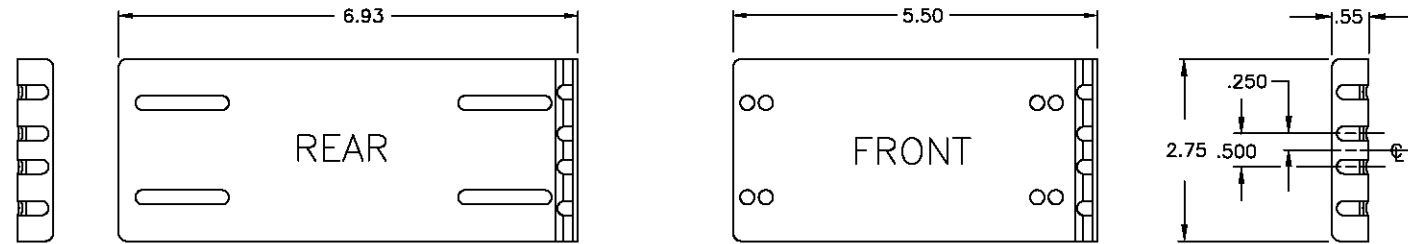

CM 12

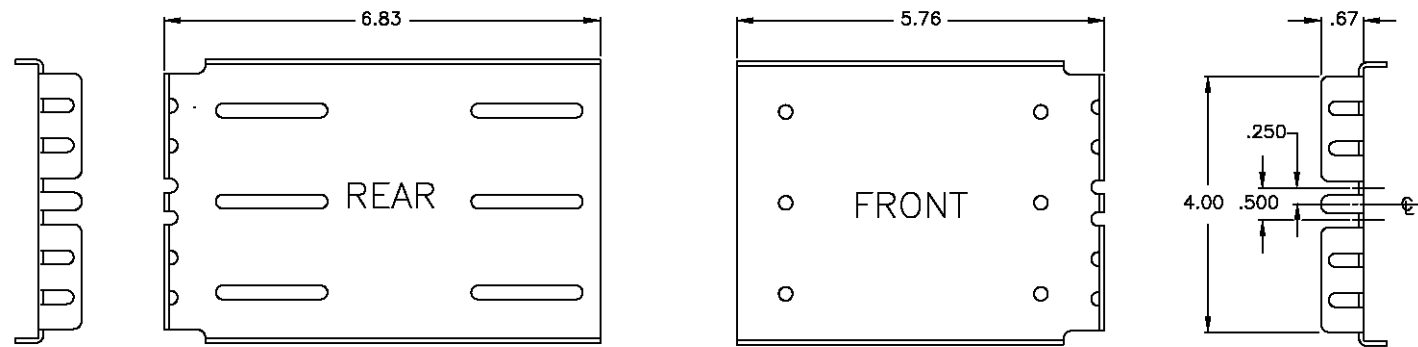

CM 14

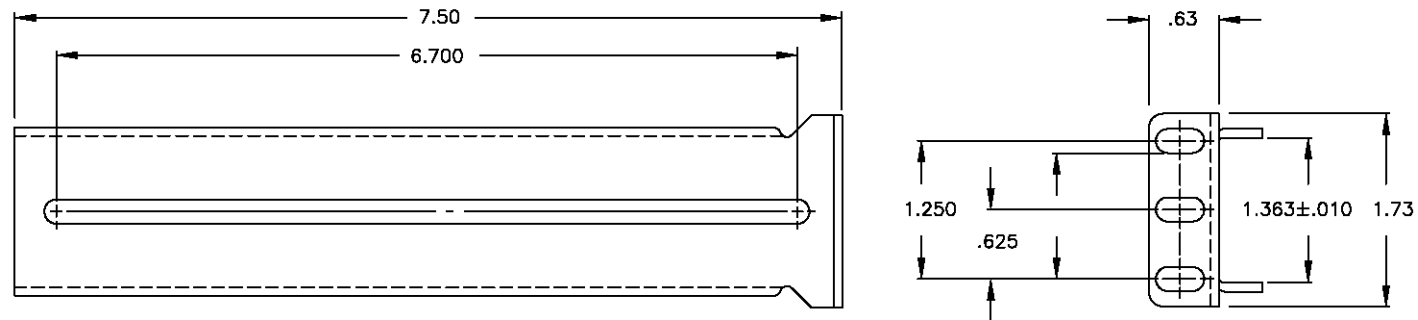

- A CM14 bracket kit consists of two CM5 brackets for the front of the slide and two CM14 brackets for adjustable mounting at the rear of the slide.



B-200/300

Designed for tension or compression loading.
Slide locks in the extended position.

Slides are identical, except the B-300 has automatic release from the extended position.

10" - 30" lengths available.



C-7000

Linear bearing bottom mount slide.

Standard slide has positive stops but does not lock at any position.

Optional lock-out feature is readily available.

10" - 30" lengths available



C-938

Designed for compression loading only and must be disconnected to mount chassis section.

Optional lock-in lock-out feature is available.

Load capacity is based on one slide at the full extension, with load at midpoint of the slide. For increased load requirements, multiply the number of slides required for the application.



D-1050/1054

Extra heavy duty bottom mount slide.

The D-1054 is the same as the D-1050, however, the D-1054 slide locks at the fully closed position and at the fully extended position.

Both slide models operate on solid rollers for vertical alignment and ball bearings for horizontal thrust.

B-200/B-300



Solid Bearing Bottom Mount Slide For Tension Or Compression Loading

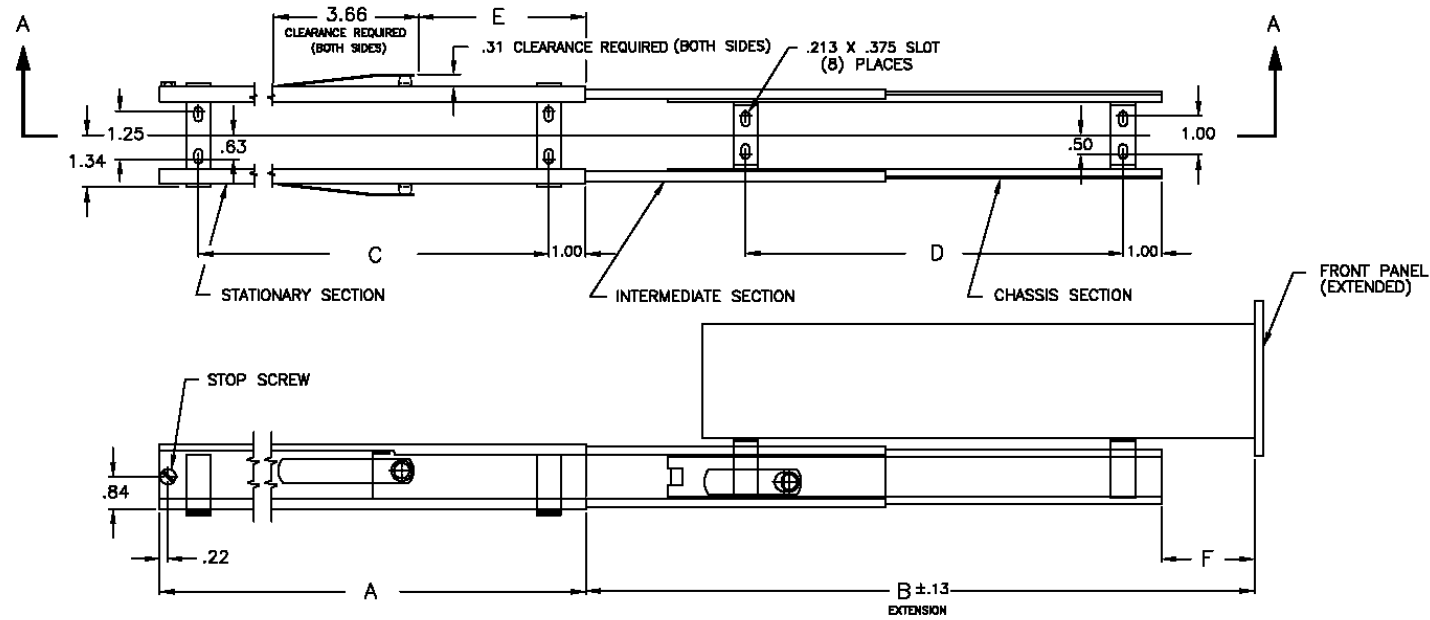

SECTION A-A

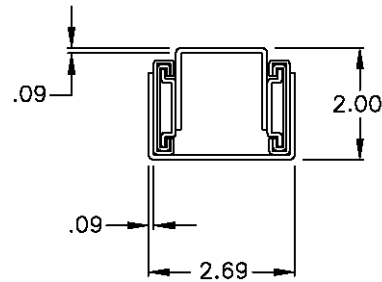

TO ORDER, SPECIFY
B-200 — XX
For Automatic Release
B-300 — XX

Catalog Number	A	B	C	D	E	F	Load Capacity
B-200-10	10.0	11.0	8.0	5.63	2.31	0.13	150 LBS.
B-200-12	12.0	13.0	10.0	5.63	2.31	2.13	150 LBS.
B-200-14	14.0	15.0	12.0	9.63	4.31	0.13	150 LBS.
B-200-16	16.0	17.0	14.0	9.63	4.31	2.13	150 LBS.
B-200-18	18.0	19.0	16.0	9.63	4.31	4.13	150 LBS.
B-200-20	20.0	21.0	18.0	15.63	7.31	0.13	115 LBS.
B-200-22	22.0	23.0	20.0	15.63	7.31	2.13	115 LBS.
B-200-24	24.0	25.0	22.0	15.63	7.31	4.13	115 LBS.
B-200-26	26.0	27.0	24.0	21.63	10.31	0.13	90 LBS.
B-200-28	28.0	29.0	26.0	21.63	10.31	2.13	90 LBS.
B-200-30	30.0	31.0	28.0	21.63	10.31	4.13	90 LBS.

Notes

- Slides are sold as non-handed items.
- Finish: All standard slides are coated with Poxylube™ dry film lubricant.
- All standard slides are designed to lock in the extended position. If this feature is not desirable, order model B-300 for automatic release.
- Standard hardware packages include all hardware necessary to mount your Chassis Trak® slides.
- All sliding members of this slide are made from cold rolled steel.
- All Chassis Trak® solid bearing slides are supplied with a quick disconnect feature. This permits the entire chassis to be easily removed and replaced.
- Optional mounting patterns, slide lengths and extensions are available.
- Load capacity is based on one slide at full extension with the load (center of gravity) at the midpoint of the slide (chassis section). This capacity has a 100% static (non-moving) load safety factor at full extension. It is not intended for operation with loads exceeding specified load capacity. For increased load capacity, multiply the number of slides required for the application.

Linear Bearing Bottom Mount Slide For Tension Or Compression Loading

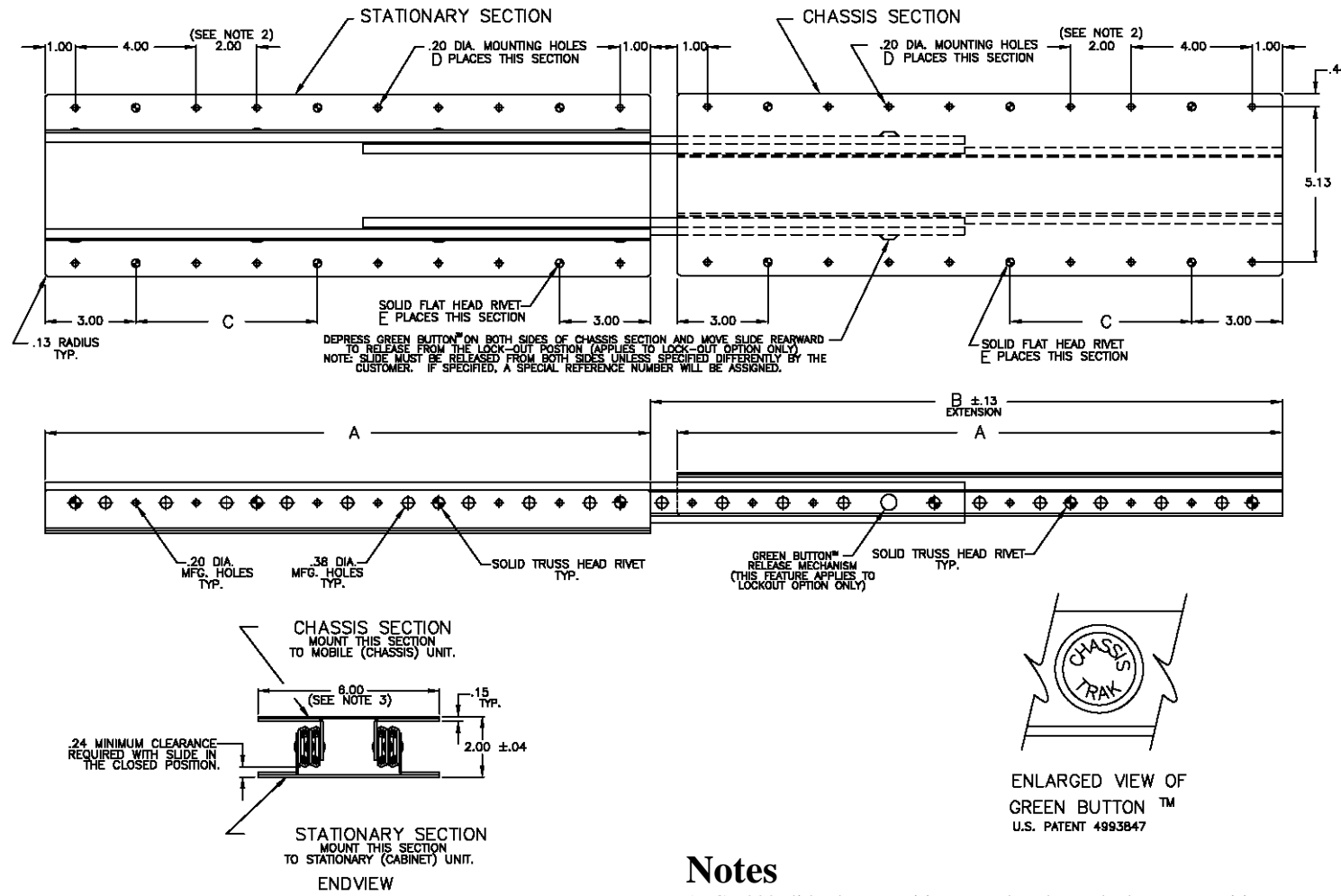

TO ORDER, SPECIFY

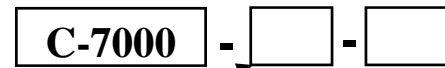

Length (Dim. A) LO - For Locking At Fully Extended Position

Catalog Number	A	B	C	D	E	Load Capacity
C-7000-10	10.0	10.88	OMIT	6	4	180 LBS.
C-7000-12	12.0	12.88	OMIT	8	4	175 LBS.
C-7000-14	14.0	14.88	4.00	8	6	170 LBS.
C-7000-16	16.0	16.88	4.00	10	6	160 LBS.
C-7000-18	18.0	18.88	6.00	12	6	150 LBS.
C-7000-20	20.0	20.88	6.00	14	6	145 LBS.
C-7000-22	22.0	22.88	8.00	16	6	130 LBS.
C-7000-24	24.0	24.88	8.00	18	6	115 LBS.
C-7000-26	26.0	26.88	10.00	20	6	105 LBS.
C-7000-28	28.0	28.88	10.00	22	6	90 LBS.
C-7000-30	30.0	30.88	12.00	24	6	75 LBS.

Notes

- C-7000 slides have positive stops but do not lock at any position. Optional lock-out feature is readily available (see order specification chart).
- This dimension is typical except where hole is replaced with solid flat head rivet.
- This dimension is standard, but may be changed readily to meet customer requests (4.31 minimum dimension). For additional modifications, contact the factory.
- Finish: clear zinc commercial plating.
- Ball bearing rollers are lubricated with -45°F to +350°F temperature range grease.
- Load capacity is based on one slide at full extension with the load (center of gravity) at the midpoint of the slide (chassis section). This capacity has a 100% static (non-moving) load safety factor at full extension. It is not intended for operation with loads exceeding specified load capacity. For increased load capacity, multiply the number of slides required for the application.
- Slide is designed for compression or suspension loading.
- Slide members and plate are made of 14 gage (.074) cold rolled steel.
- Standard mounting hardware package is included with each slide assembly.
- Other non-standard options are available including other finishes and lock-in features. These options require a special reference number.

Roller Bearing Bottom Mount Slide

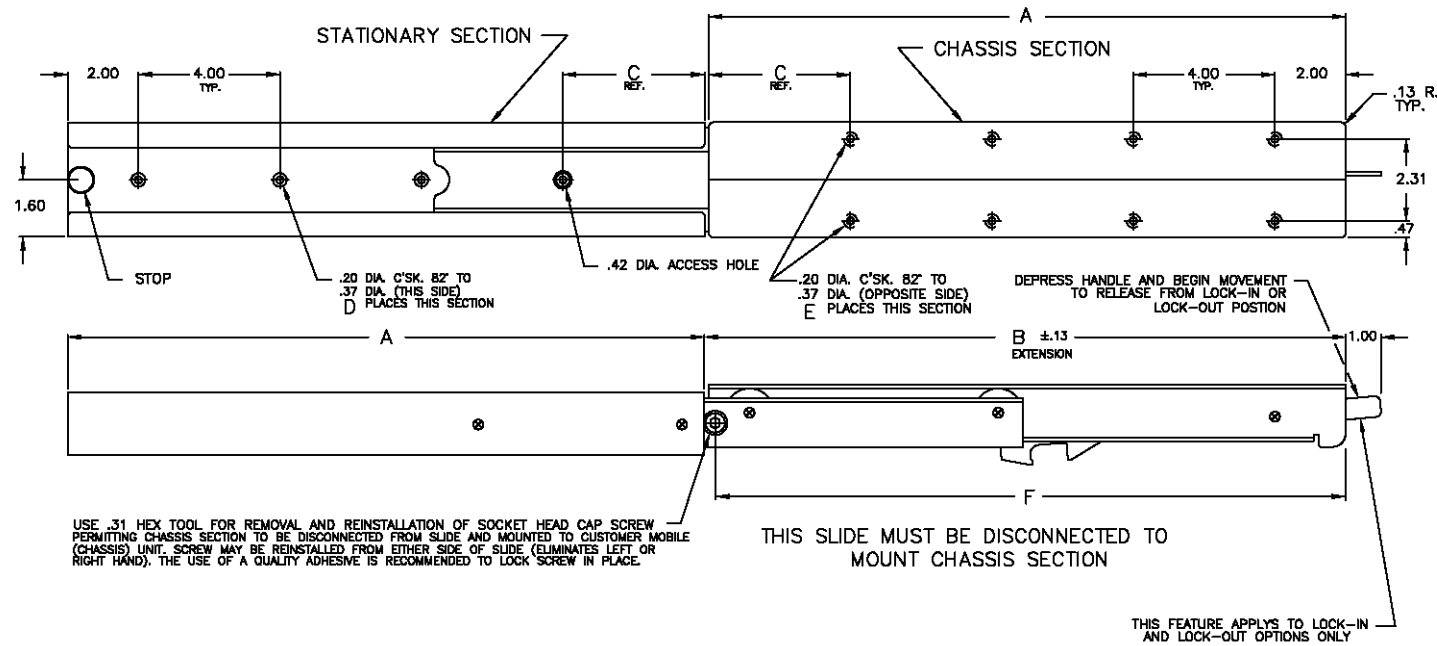

TO ORDER, SPECIFY

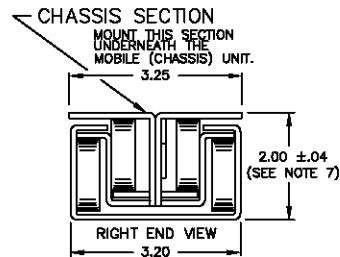
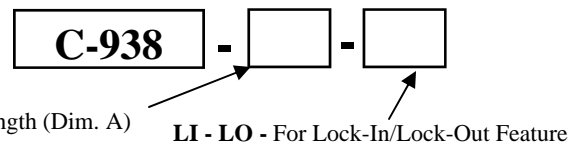

Catalog Number	A	B	C	D	E	F	Load Capacity
C-938-12	12.0	12.06	2.00	3	6	11.67	400 LBS.
C-938-14	14.0	14.06	4.00	3	6	13.67	335 LBS.
C-938-16	16.0	16.06	2.00	4	8	15.67	285 LBS.
C-938-18	18.0	18.06	4.00	4	8	17.67	250 LBS.
C-938-20	20.0	20.06	2.00	5	10	19.67	220 LBS.
C-938-22	22.0	22.06	4.00	5	10	21.67	200 LBS.
C-938-24	24.0	24.06	2.00	6	12	23.67	180 LBS.
C-938-26	26.0	26.06	4.00	6	12	25.67	165 LBS.
C-938-28	28.0	28.06	2.00	7	14	27.67	155 LBS.
C-938-30	30.0	30.06	4.00	7	14	29.67	140 LBS.
C-938-32	32.0	32.06	2.00	8	16	31.67	130 LBS.
C-938-34	34.0	34.06	4.00	8	16	33.67	125 LBS.
C-938-36	36.0	36.06	2.00	9	18	35.67	120 LBS.
C-938-38	38.0	38.06	4.00	9	18	37.67	110 LBS.
C-938-40	40.0	40.06	2.00	10	20	39.67	105 LBS.
C-938-42	42.0	42.06	4.00	10	20	41.67	100 LBS.
C-938-44	44.0	44.06	2.00	11	22	43.67	95 LBS.
C-938-46	46.0	46.06	4.00	11	22	45.67	90 LBS.
C-938-48	48.0	48.06	2.00	12	24	47.67	85 LBS.

Notes

- Standard C-938 has no locking features.
- Optional lock-in/lock-out feature is available.
- Finish: E-Coat conversion coating or clear zinc commercial plating.
- Load capacity is based on one slide at full extension with the load (center of gravity) at the midpoint of the slide (chassis section). For increased load capacity, multiply the number of slides required for the application.
- Stated load capacity has a 100% static (non-moving) load safety factor at full extension. Slide is not intended to be operated with continuous loading which exceeds stated capacities.
- Ball bearing rollers are lubricated with -45°F to +350°F temperature range grease.
- Measured in the closed (retracted) position.
- Slide members are made from 12 gage (.105) cold rolled steel.
- Other non-standard options including finishes and stainless steel slides are available. These options require a special reference number.
- No mounting hardware supplied.
- Slide is designed for compression or suspension loading.

Extra Heavy Duty Bottom Mount Slides

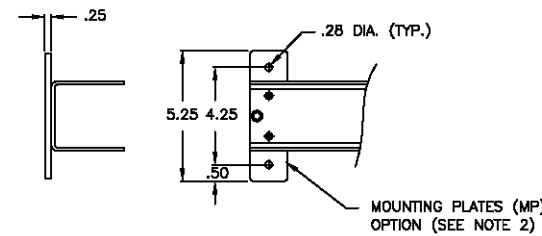
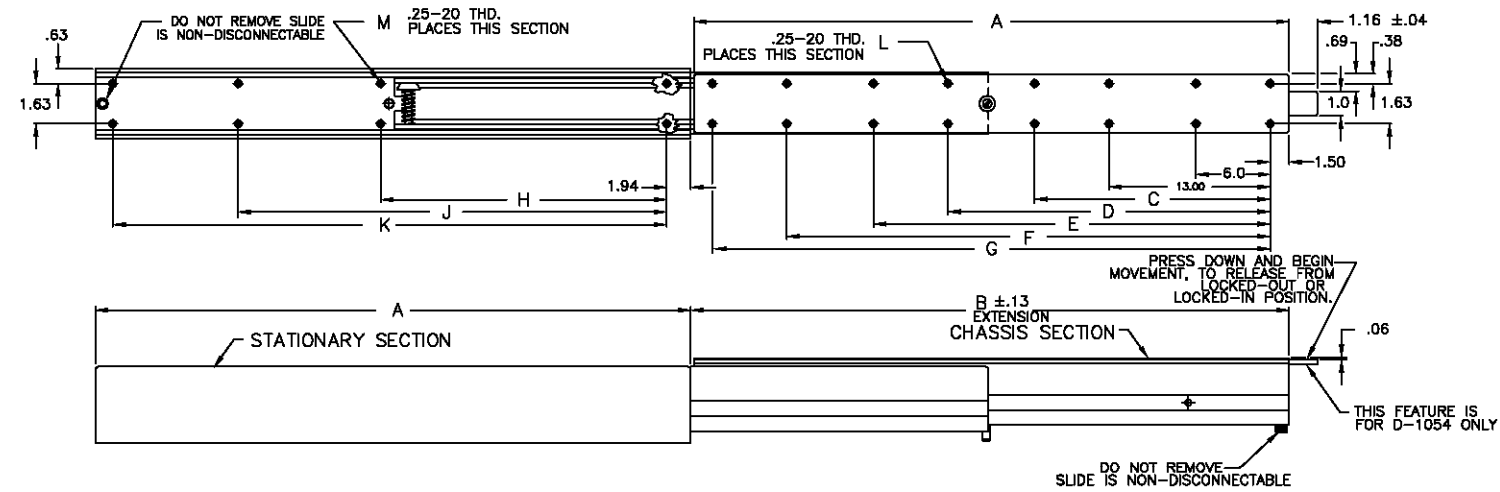

TO ORDER, SPECIFY

D-1050/1054 - -

Length (Dim. A) MP - Mounting Plate

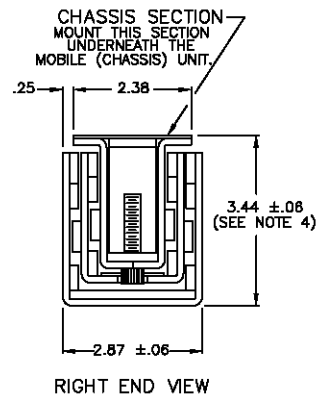

Notes

- Catalog number D-1054 designates the same slide as D-1050, however, the D-1054 slide locks at the fully closed position (LI) and at the fully extended position (LO).
- Stationary section is designed for mounting from the bottom (threaded holes). If application requires mounting stationary section from the top side, order optional mounting plates.
- Slide operates on solid rollers for vertical alignment and ball bearings for horizontal thrust.
- Measured in the closed (retracted) position.
- Load capacity is based on one slide at full extension with the load (center of gravity) at the midpoint of the slide (chassis section).

Catalog Number	A	B	C	D	E	F	G	H	J	K	L	M	Load Capacity
D-1050/1054-18	18.0	18.0	OMIT	OMIT	OMIT	OMIT	15.0	8.06	OMIT	15.34	8	6	1270 LBS.
D-1050/1054-20	20.0	20.0	OMIT	OMIT	OMIT	OMIT	17.0	9.06	OMIT	17.34	8	6	1140 LBS.
D-1050/1054-22	22.0	22.0	OMIT	OMIT	OMIT	OMIT	19.0	10.06	OMIT	19.34	8	6	1035 LBS.
D-1050/1054-24	24.0	24.0	19.0	OMIT	OMIT	OMIT	21.0	11.06	OMIT	21.34	10	6	950 LBS.
D-1050/1054-26	26.0	26.0	19.0	OMIT	OMIT	OMIT	23.0	12.06	OMIT	23.34	10	6	875 LBS.
D-1050/1054-28	28.0	28.0	19.0	OMIT	OMIT	OMIT	25.0	13.06	OMIT	25.34	10	6	815 LBS.
D-1050/1054-30	30.0	30.0	19.0	OMIT	OMIT	OMIT	27.0	14.06	OMIT	27.34	10	6	760 LBS.
D-1050/1054-32	32.0	32.0	19.0	OMIT	OMIT	OMIT	29.0	15.06	OMIT	29.34	10	6	710 LBS.
D-1050/1054-34	34.0	34.0	19.0	OMIT	OMIT	OMIT	31.0	16.06	OMIT	31.34	10	6	670 LBS.
D-1050/1054-36	36.0	36.0	19.0	26.0	OMIT	OMIT	33.0	17.06	25.56	33.34	12	8	630 LBS.
D-1050/1054-38	38.0	38.0	19.0	26.0	OMIT	OMIT	35.0	18.06	27.06	35.34	12	8	600 LBS.
D-1050/1054-40	40.0	40.0	19.0	26.0	OMIT	OMIT	37.0	19.06	28.56	37.34	12	8	570 LBS.
D-1050/1054-42	42.0	42.0	19.0	26.0	32.0	OMIT	39.0	20.06	30.06	39.34	14	8	545 LBS.
D-1050/1054-44	44.0	44.0	19.0	26.0	32.0	OMIT	41.0	21.06	31.56	41.34	14	8	520 LBS.
D-1050/1054-46	46.0	46.0	19.0	26.0	32.0	OMIT	43.0	22.06	33.06	43.34	14	8	495 LBS.
D-1050/1054-48	48.0	48.0	19.0	26.0	32.0	39.0	45.0	23.06	34.56	45.34	16	8	475 LBS.

- For increased load capacity, multiply the number of slides required for the application.
- Slide is non-disconnectable.
 - Slide is designed for compression loading only.
 - To prevent internal damage to the slide, maximum mounting screw penetration cannot exceed .42" into the stationary section or .31" into chassis section.
 - No mounting hardware supplied.
 - Slide members are coated with Poxylube™ - a gray-colored dry film lubricant.
 - Slide members are made from 10 gage (.135) cold rolled steel, and 3/16 C.D. Flat Bar.
 - Non-standard stainless steel slide, coated with Poxylube™, is available. This option will require a special reference number.



Cabinet Accessories

General Devices offers a full selection of electronic cabinets and enclosure related hardware.

- Writing Shelves
- Storage Drawers and Sliding Shelves
- Fixed Shelves
- Utility Chassis
- Cable Carriers, Guides and Retractors
- Cooling Modules and Fan Trays



D-4080 Retractable Writing Shelf

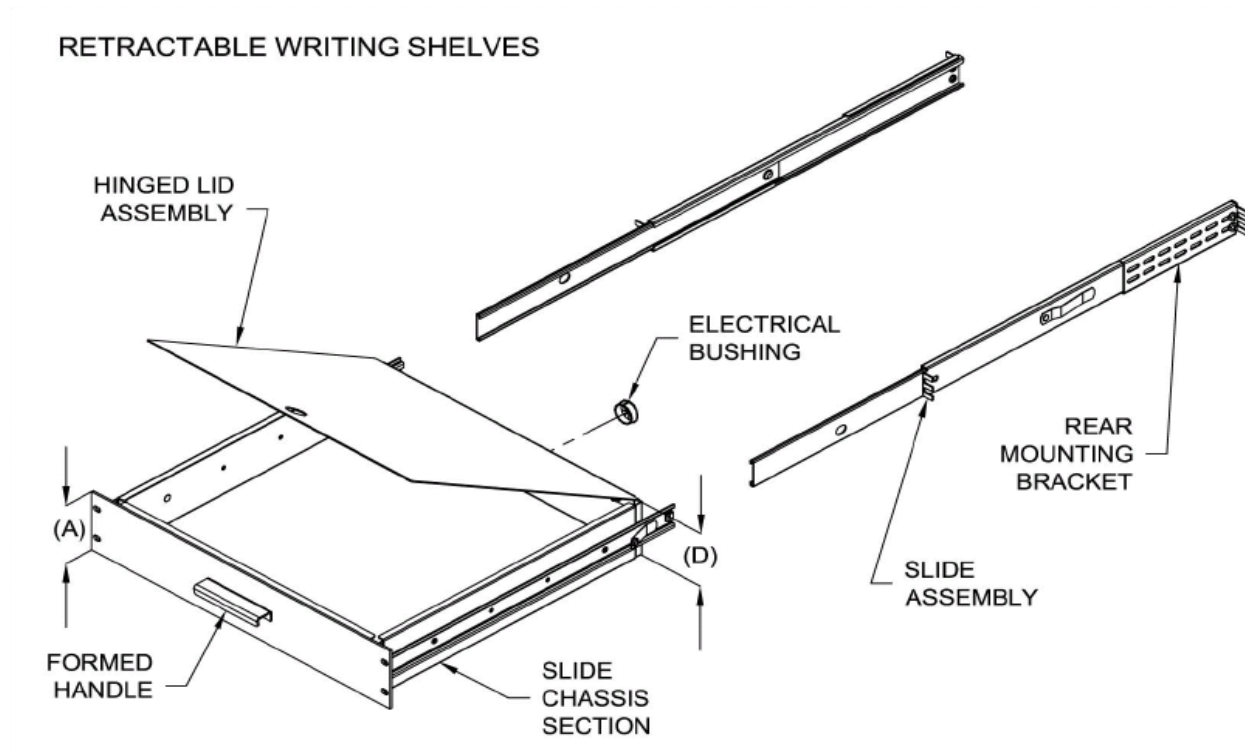

Slide assemblies with rear mounting brackets and assembly hardware as follows:

- TYPE **D-4080-1** uses TYPE C-300-S-420-RC-3S slide assembly and TYPE B-389 rear bracket
- TYPE **D-4080-3** & **D-4080-5** use TYPE C-300-S-120 slide assembly and TYPE B-308 rear bracket

Retractable Writing Shelves

- Shelf is designed to mount in 19" EIA electronic rack.
- Drawer has 17" width and depth.
- 12 gauge front panel with formed push-pull handle.
- Hole in rear of the drawer to accommodate electrical cord and bushing.
- Retractable writing surface has black powder coat finish.

Part Number	Panel Height (A)	Drawer Height (D)
D-4080-1	1.72	1.42
D-4080-3	3.47	3.17
D-4080-5	5.22	4.92

Storage Drawer/Sliding Shelf



D-4100 Storage Drawer

CATALOG NUMBER	A	B	C	D	E
D-4100-3	19.0	17.0	17.88	3.47	3.00
D-4100-5	19.0	17.0	17.88	5.22	4.75
D-4100-7	19.0	17.0	17.88	6.97	6.50
D-4100-8	19.0	17.0	17.88	8.72	8.25
D-4100-10	19.0	17.0	17.88	10.47	10.00
D-4100-12	19.0	17.0	17.88	12.22	11.75
D-4100-14	19.0	17.0	17.88	13.97	13.50

*24 and 30 inch panel width versions available.
Contact factory for more information.

1. Storage drawer body (16 gauge C.R.S. with semi-gloss black finish).
2. Front panel (12 gauge C.R.S. with semi-gloss black finish).
3. Handle pull.
4. Slide assembly Model C-300-S-122
5. B-308 extension bracket.

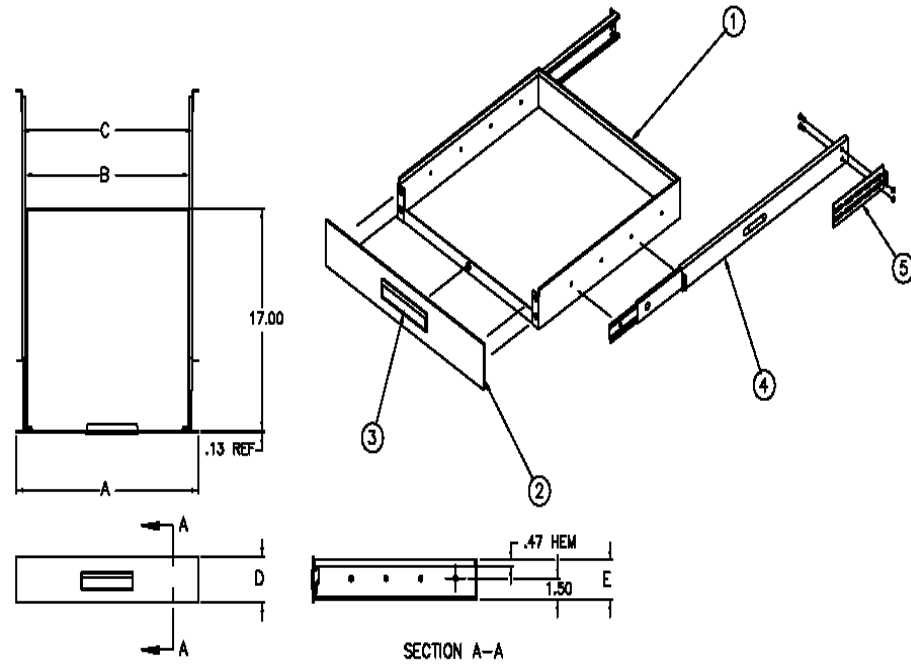

D-4454 Sliding Shelf

19" PANEL WIDTH*			
CATALOG NUMBER	A	B	C
D-4454-19x20	18.31	17.0	20.0
D-4454-19x22	18.31	17.0	22.0
D-4454-19x24	18.31	17.0	24.0
D-4454-19x26	18.31	17.0	26.0
D-4454-19x28	18.31	17.0	28.0
D-4454-19x30	18.31	17.0	30.0

*24 and 30 inch panel width versions available.
Contact factory for more information.

- Finish: Semi-gloss black.
Mounting hardware included (B-309 brackets).
Contact factory for optional perforated ventilation.

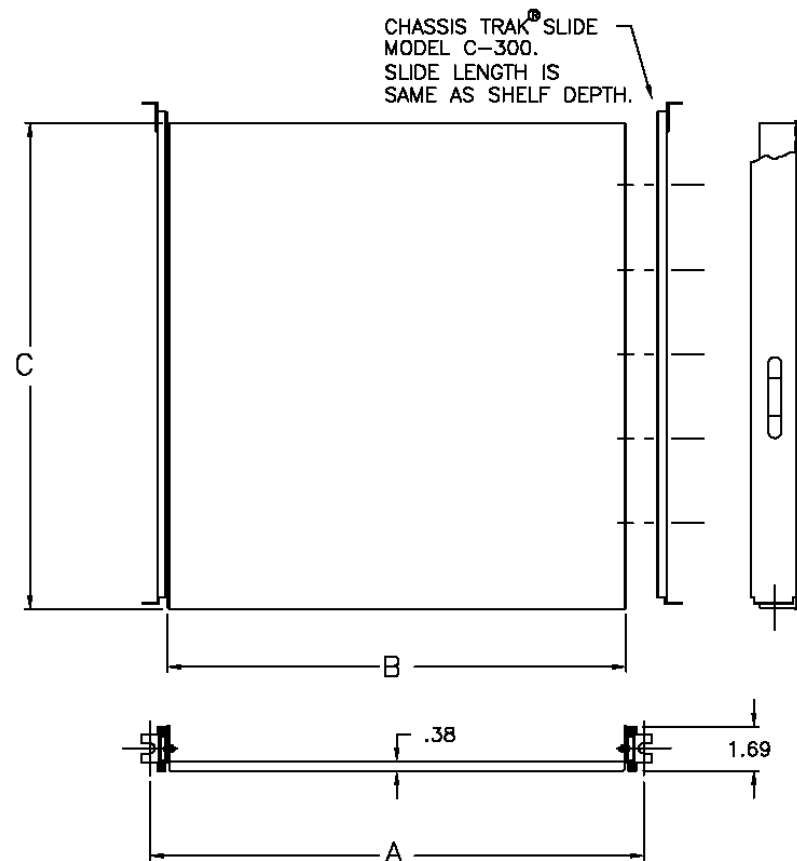

Sliding Shelf

C-7100 Ball Bearing Sliding

Catalog Number	A	B
C-7100-10-CM1	10.22	11.00
C-7100-12-CM1	12.22	13.00
C-7100-14-CM1	14.22	15.00
C-7100-16-CM1	16.22	17.00
C-7100-18-CM1	18.22	19.00
C-7100-20-CM1	20.22	21.00
C-7100-22-CM1	22.22	23.00
C-7100-24-CM1	24.00	25.00
C-7100-26-CM1	26.22	27.00
C-7100-28-CM1	28.22	29.00
C-7100-30-CM1	30.00	31.00

CHASSIS TRAK® SLIDE
MODEL LBS-12
SLIDE LENGTH IS SAME
AS SHELF DEPTH.

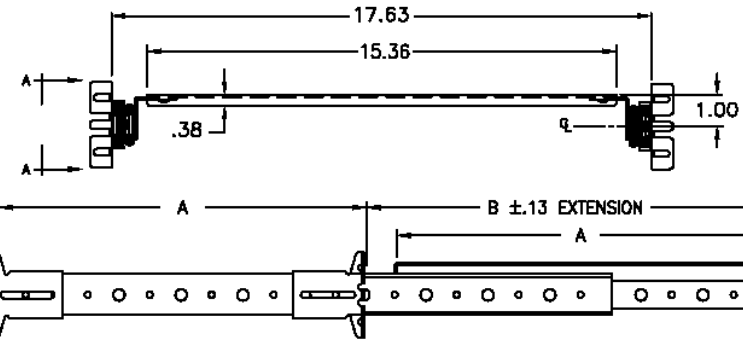
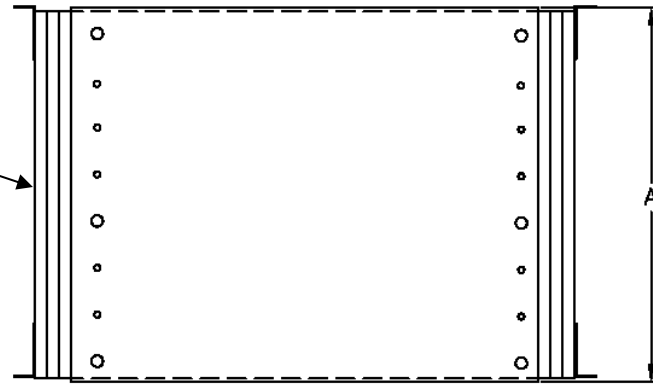

Finish: Clear zinc commercial plating

CM1 STYLE MOUNTING BRACKETS (SUPPLIED WITH SHELF)

(SEE MATRIX ON PAGE 48 FOR OPTIONAL MOUNTING BRACKETS DESIGNED FOR USE WITH MODEL LBS-12)

C-71307 Ball Bearing Sliding

Catalog Number	A	B
C-71307-12-CM5	12.00	13.00
C-71307-14-CM5	14.00	15.00
C-71307-16-CM5	16.00	17.00
C-71307-18-CM5	18.00	19.00
C-71307-20-CM5	20.00	21.00
C-71307-22-CM5	22.00	23.00
C-71307-24-CM5	24.00	25.00
C-71307-26-CM5	26.00	27.00
C-71307-28-CM5	28.00	29.00
C-71307-30-CM5	30.00	31.00

CHASSIS TRAK® SLIDE
MODEL CLB-307
SLIDE LENGTH IS SAME
AS SHELF DEPTH.

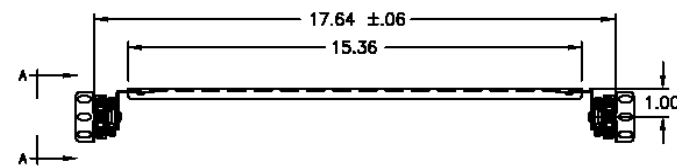
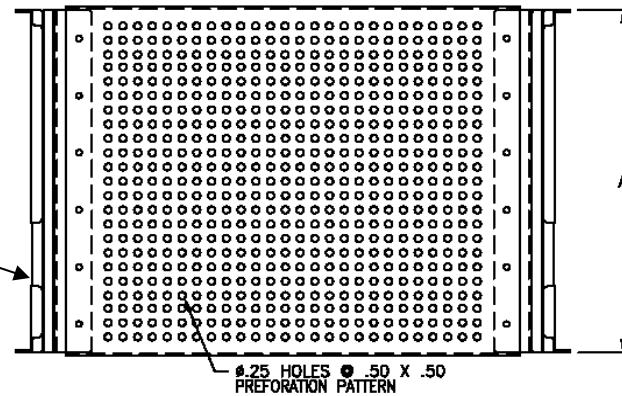

Finish: Clear zinc commercial plating

DEPRESS GREEN BUTTON® (BOTH SIDES OF SLIDE ASSEMBLY) AND BEGIN REARWARD MOVEMENT TO RELEASE FROM LOCK-OUT POSITION.

(CM5 BRACKETS SUPPLIED WITH SHELF; SEE MATRIX ON PAGE 48 FOR ALTERNATIVE MOUNTING BRACKETS DESIGNED FOR USE WITH MODEL CLB-307)

Fixed Shelves



D-4451 Adjustable Fixed Shelf

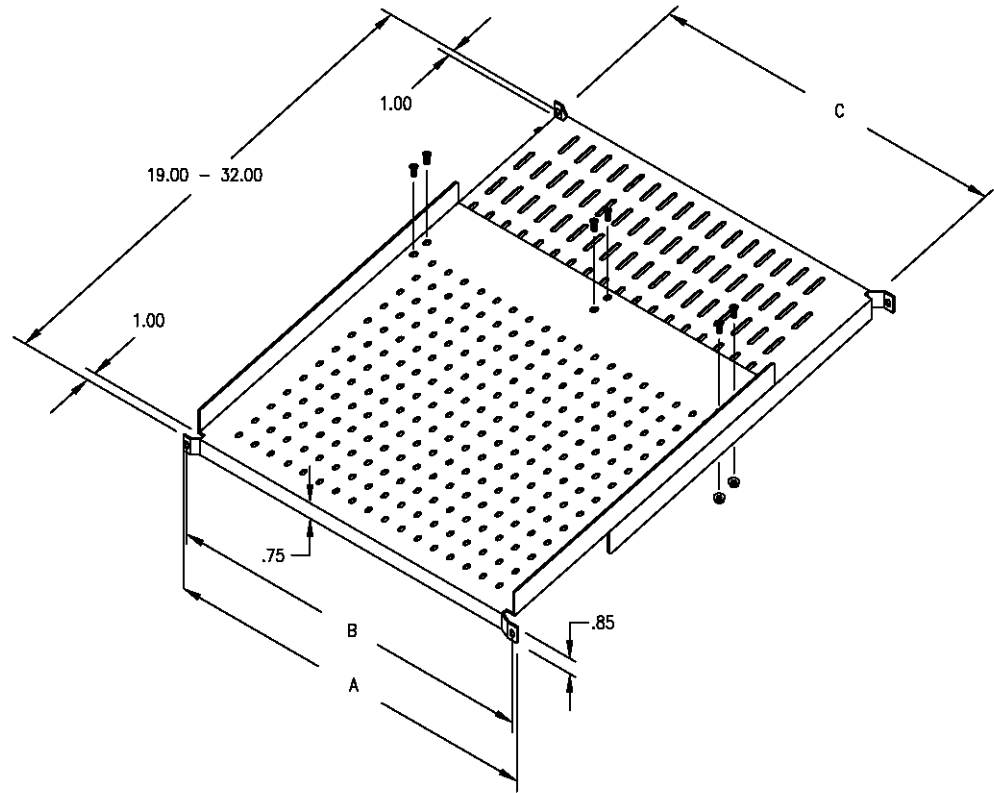

Adjustable fixed shelf is ideal for installing equipment that cannot be rack mounted.

Adjusts to multiple mounting depths from 19" - 32".

Perforated for additional cooling.

Sturdy 14-gauge steel construction. 75-lb. capacity.

Fits 19" panel width.

Finish: Semi-gloss black

D-6064 Fixed Shelf

CATALOG NUMBER	A	B	C	D (Depth)	E
D-6064-19x18	19.06	18.31	17.88	17.94	16.81
D-6064-19x20	19.06	18.31	17.88	19.94	18.81
D-6064-19x22	19.06	18.31	17.88	21.94	20.81
D-6064-19x24	19.06	18.31	17.88	23.94	22.81
D-6064-19x26	19.06	18.31	17.88	25.94	24.81
D-6064-19x28	19.06	18.31	17.88	27.94	26.81

*24 and 30 inch panel width versions available.
Contact factory for more information.

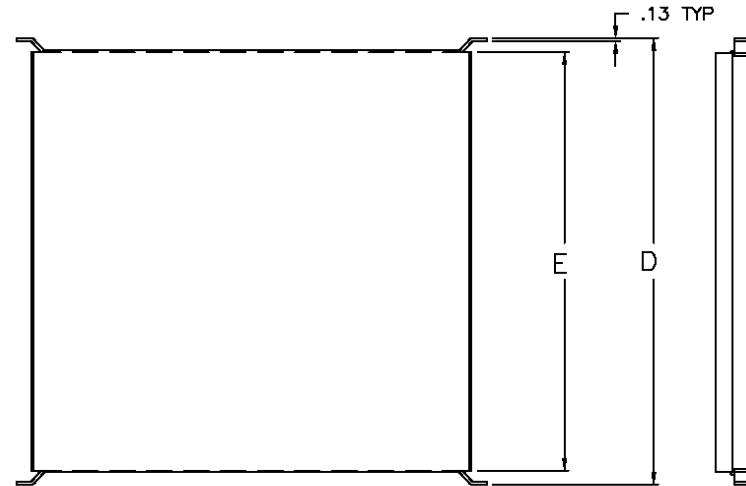

Finish: Semi-gloss black.
Mounting hardware included.
Material: 14-gauge C.R.S. (.074").
Contact factory for optional perforated ventilation

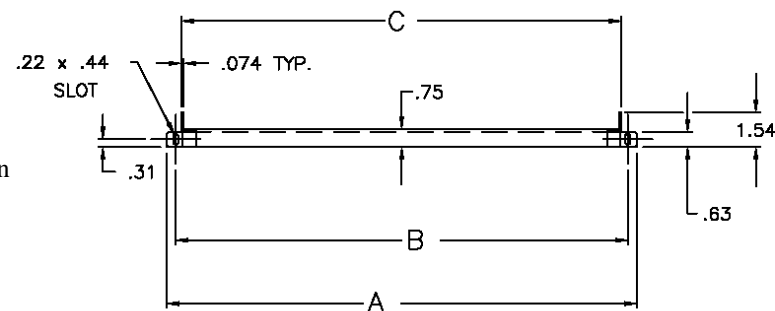

Shelves



D-4455 1U All In One Shelf

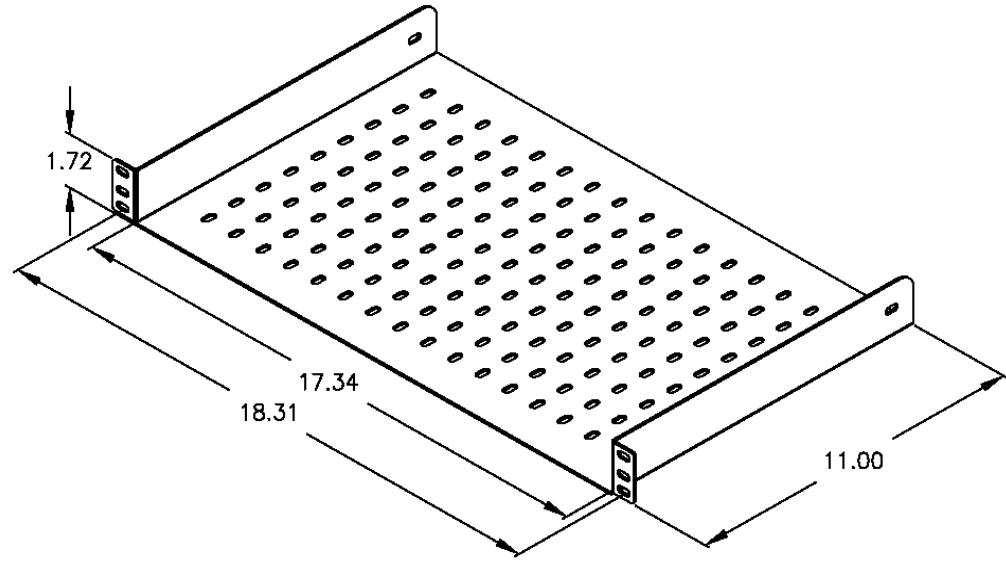

D-4455 all-in-one shelf mounts equipment on the inside or the outside of standard 19" enclosures and racks. Rugged 14-gauge steel construction.

Perforated to help keep equipment cool.

Finish: Semi-gloss black

D-4456 2U All In One Shelf

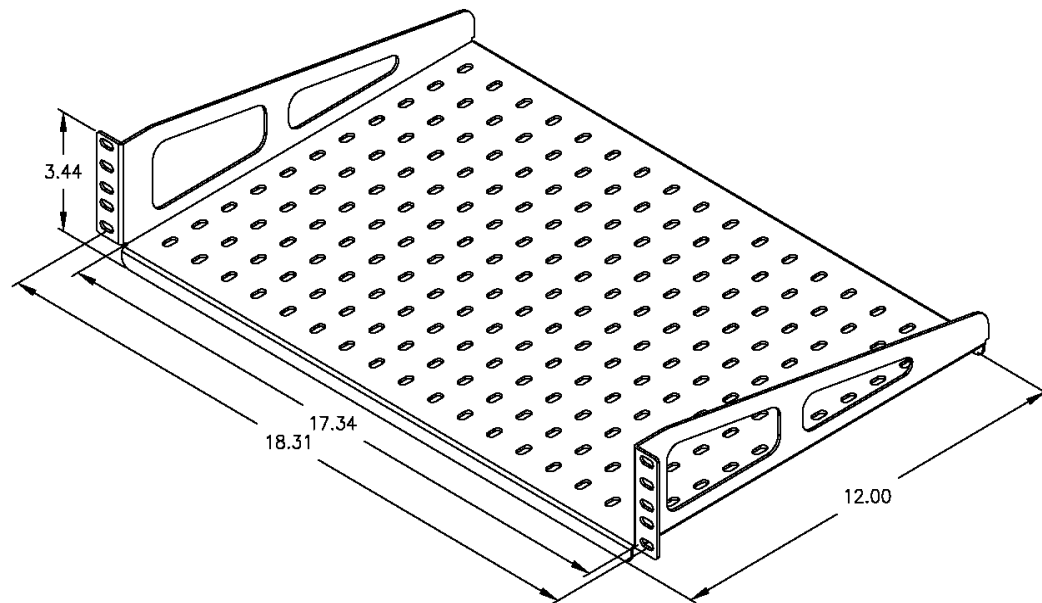

D-4456 all-in-one shelf mounts equipment on the inside or the outside of standard 19" enclosures and racks. Rugged 14-gauge steel construction.

Perforated to help keep equipment cool.

Finish: Semi-gloss black

Shelves



D-4457 2U Clip on Rack Shelf

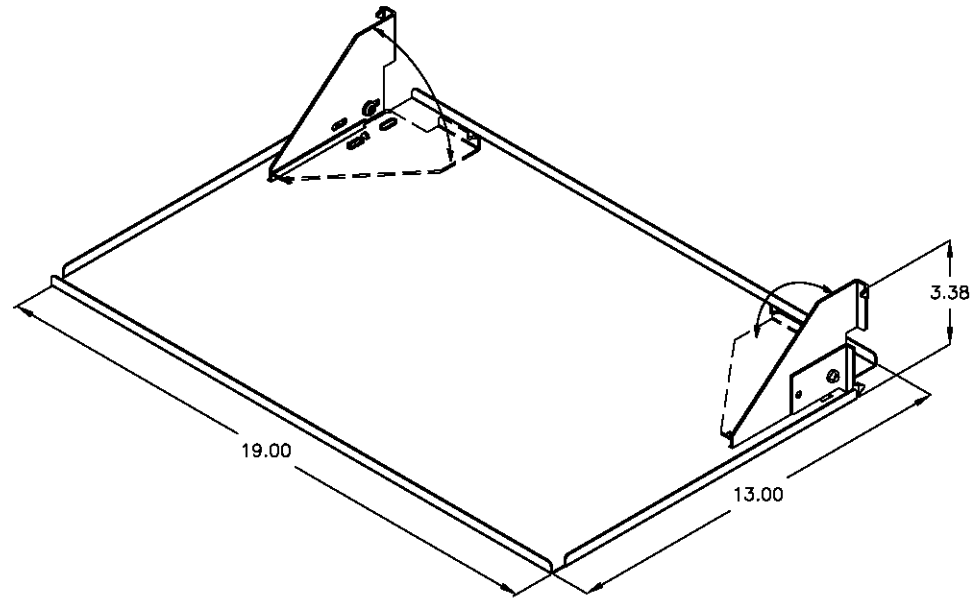

D-4457 Clip on Shelf with black powder coat finish. Shelf is designed to clip on any standard EIA versatile mounting rail.

Can be used as a temporary keyboard, laptop, instrument or tool tray.

Shelf folds away to 19" x 13" x 1" for storage or carrying.

Finish: Semi-gloss black

D-4458 Fixed Relay Rack Shelf

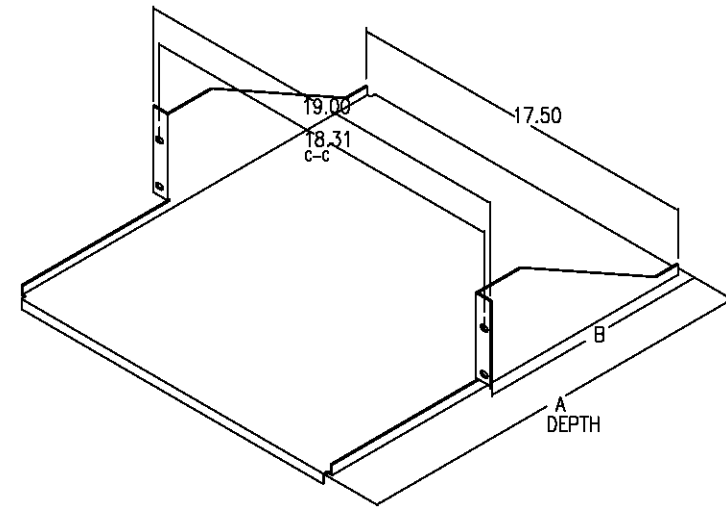

D-4458 Fixed Relay Rack Shelf is designed to fit 19" open relay racks. Heavy duty 14-gauge steel construction.

Finish: Cloud white powder coat paint

Catalog Number	A	B
D-4458-20	20.0	11.50
D-4458-24	24.0	13.50
D-4458-30	30.0	16.50

D-4460 Relay Rack Shelf

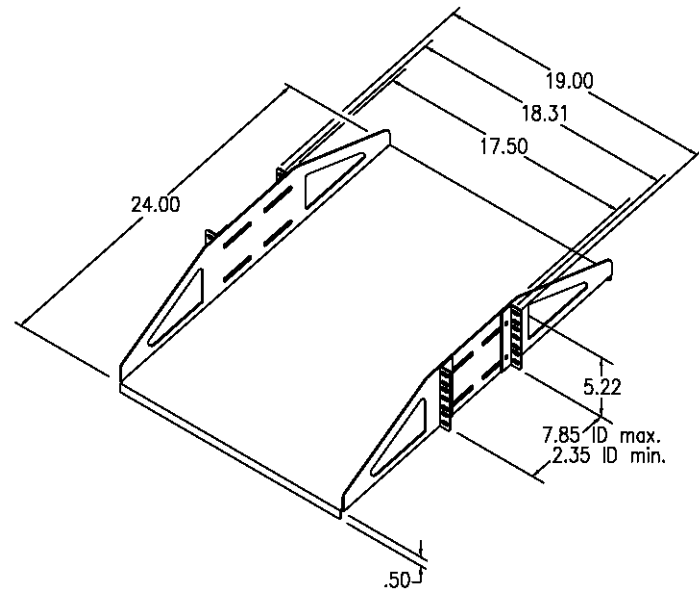

D-4460 Fixed Relay Rack Shelf is designed to fit 19" open relay racks - adjustable mounting brackets are included.

Heavy duty 14-gauge steel construction.

Finish: Cloud white powder coat paint

B-4470 Chassis Support Bracket

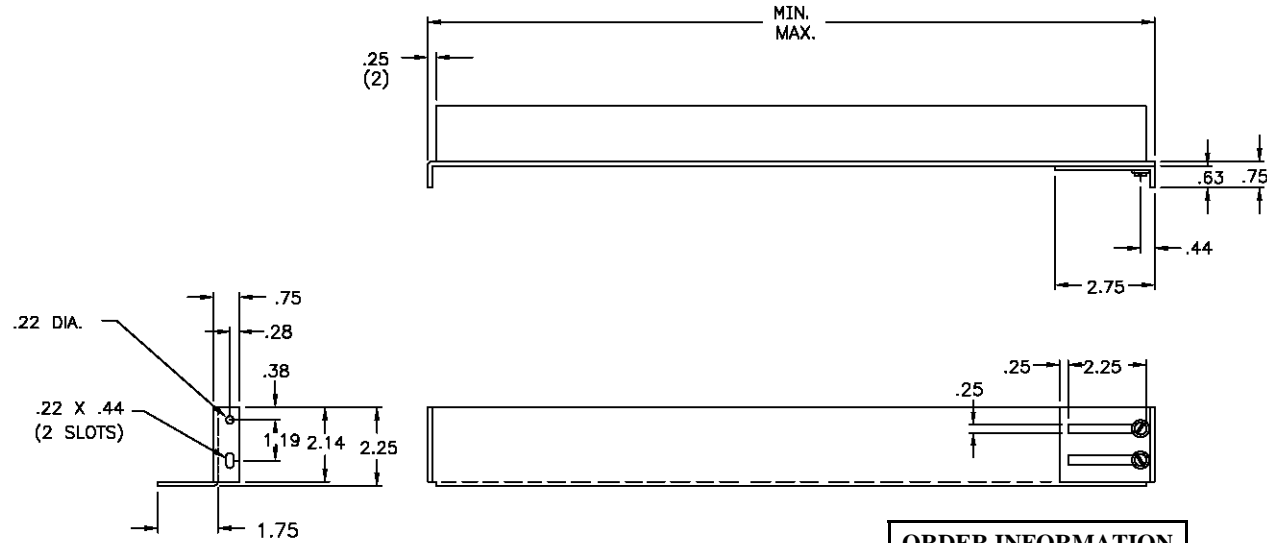

Finish: Clear zinc commercial plating
 Material: 12 gauge C.R.S.
 Other sizes available in 2" increments

ORDER INFORMATION		
SPECIFY	MIN.	MAX.
B-4470 x 24	21.0	23.0
B-4470 x 30	27.0	29.0
B-4470 x 36	33.0	35.0

C-8505 Hardware Pull

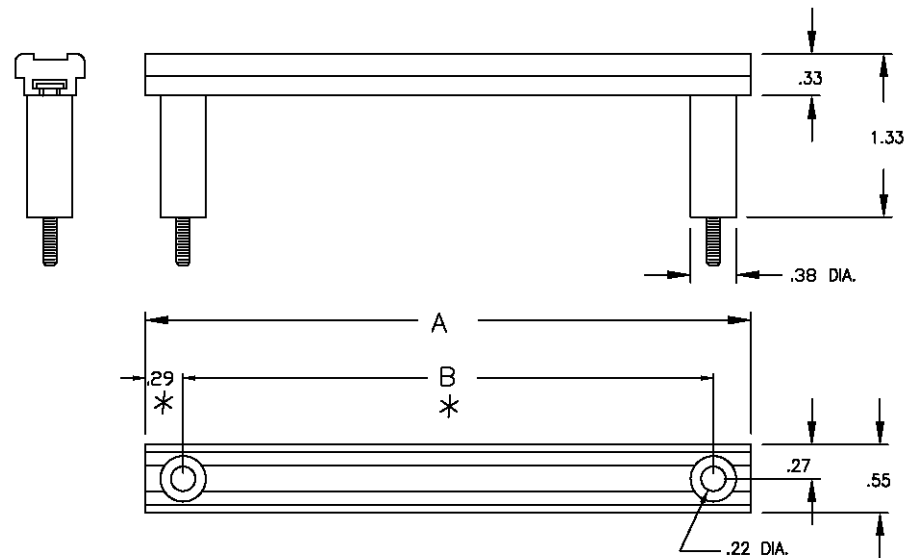

SPECIFY	OVERALL LENGTH A	HOLE C-C B*
C-8505-3	3.25	2.66
C-8505-5	5.00	4.41
C-8505-7	6.75	6.16
C-8505-8	8.50	7.91
C-8505-10	10.25	9.66
C-8505-12	12.00	11.41
C-8505-14	13.75	13.16

Material: Aluminum extrusion with clear chromate conversion coating finish and black textured insert.

Mounting hardware included (sold in pairs).
 *Recommended dimension
 Dim. B can vary at customer request.

D-4001 1.75" Utility Chassis

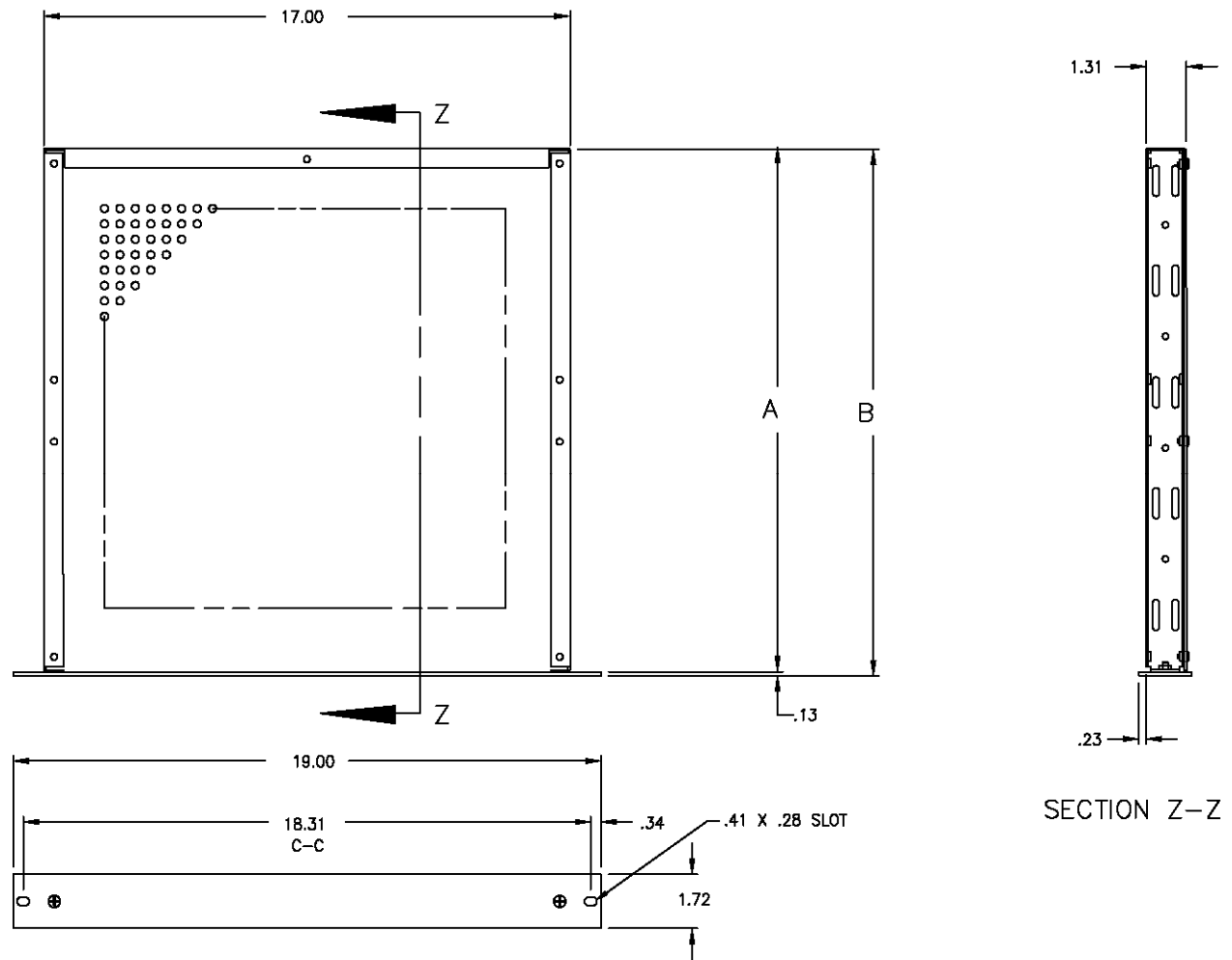

Ordering Information

CHA - XX - XX

Accessory Series

Front Panel Height
Specify
01

Chassis Depth		
Specify	Depth Dim. A	Overall Dim. B
08	8.50	8.63
12	12.75	12.88
17	17.00	17.13

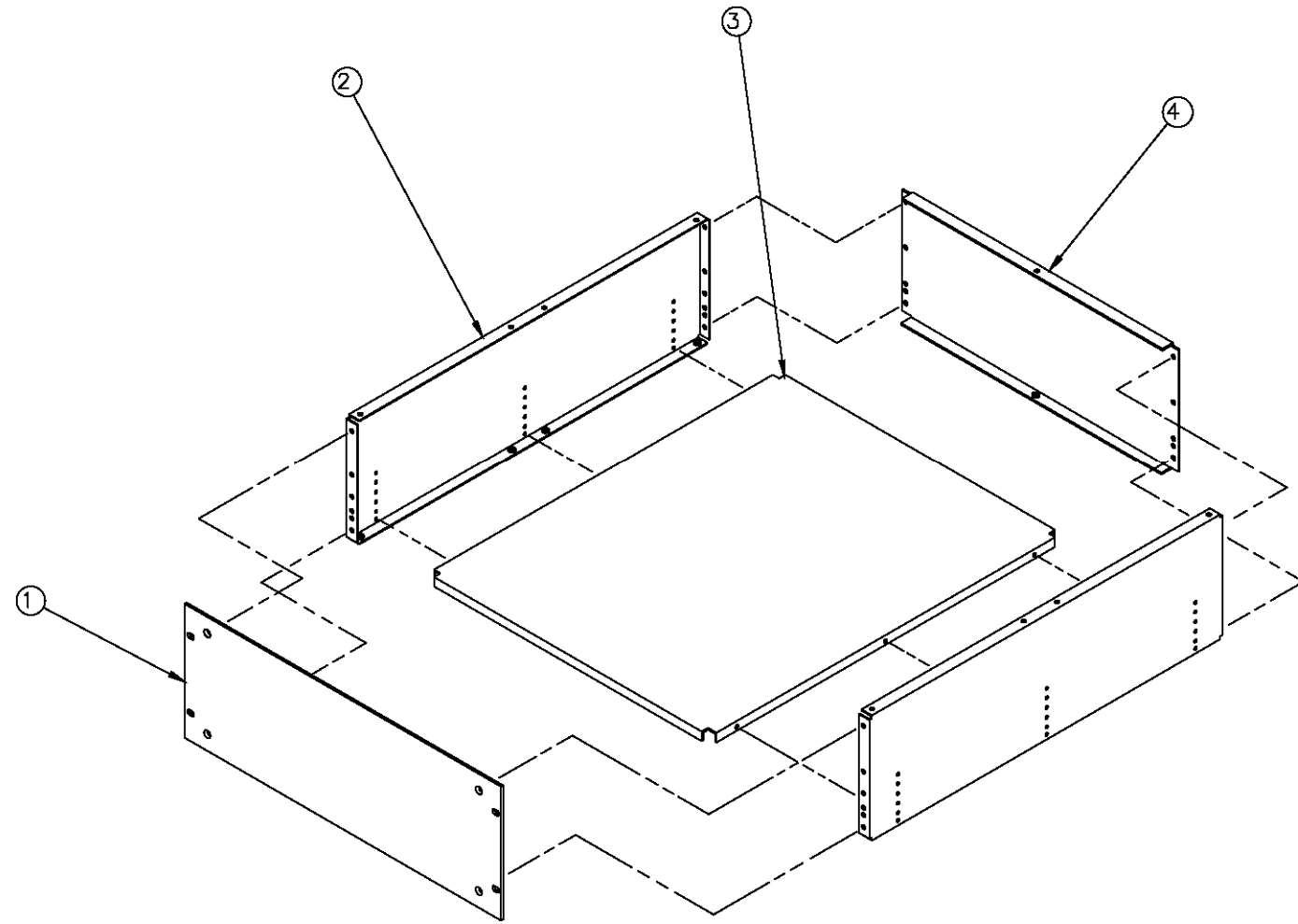

Notes

1. Front panel (.125" aluminum; Finish: Clear chromate conversion coating).

2. Chassis side panel (2 each; .062" aluminum; Finish: Clear chromate conversion coating).

3. Chassis bottom plate (.090" aluminum; Finish: Clear chromate conversion coating).

4. Rear panel (.090 aluminum; Finish: Clear chromate conversion coating).

Ordering Information

CHA - XX - XX

Accessory Series

Front Panel Height		
Specify	Overall Height A	Chassis Height B
03	3.47	3.00
05	5.22	4.75
07	6.97	6.50
08	8.72	8.25
10	10.47	10.00
12	12.22	11.75
14	13.97	13.50

Chassis Depth		
Specify	Depth Dim. A	Overall Dim. B
08	8.50	8.72
12	12.75	12.97
17	17.00	17.22
21	21.25	21.47

Chassis Order includes:

- Front panel
- Chassis side panel (2 each)
- Chassis bottom plate
- Rear panel

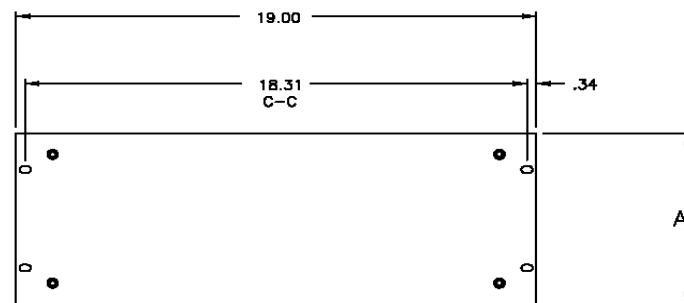
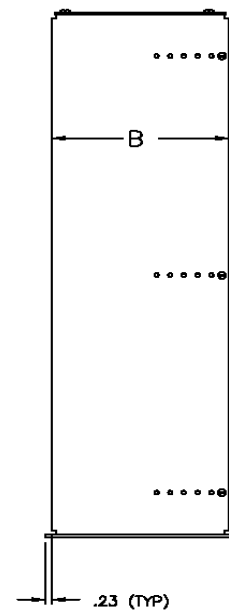
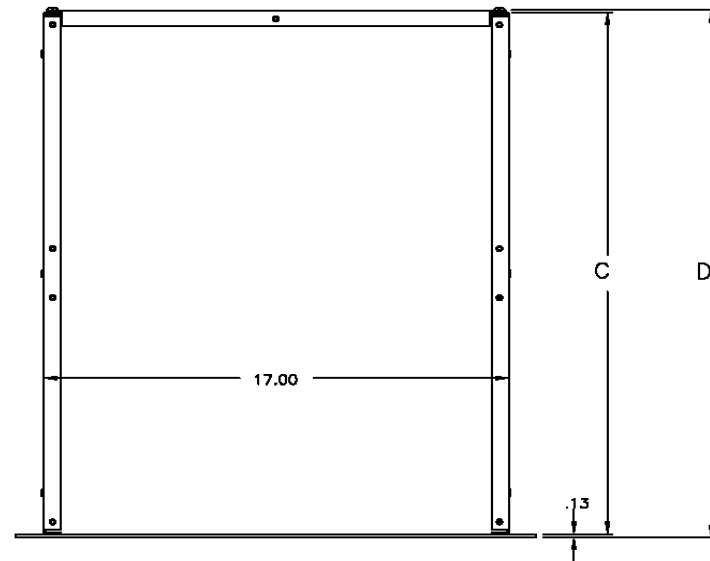

**Note, if application requires utility chassis to be rack mounted, additional holes will need to be added to side panels to accommodate slides.*

Utility Chassis Components



Front Panel

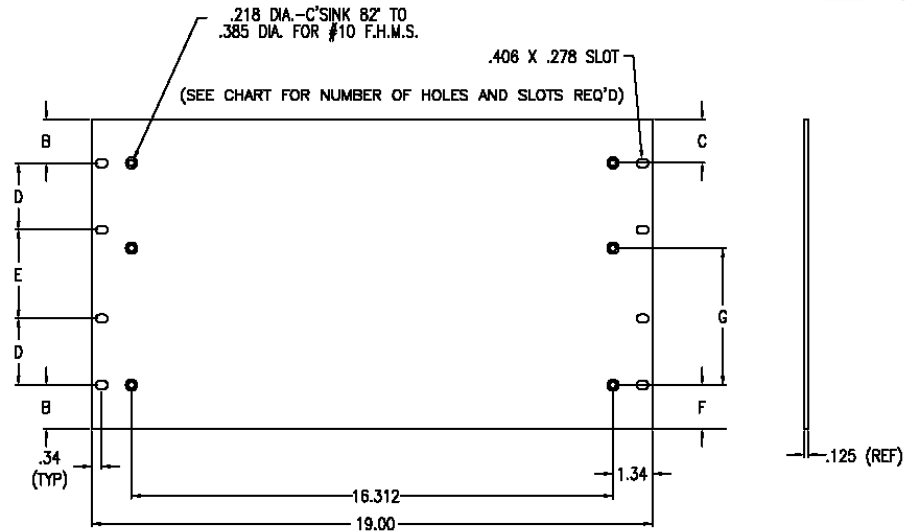

CATALOG NUMBER	A	B	C	D	E	F	G	# OF HOLES	# OF SLOTS
FPA-3	3.47	0.23	0.86	—	—	0.86	—	4	4
FPA-5	5.22	1.48	1.48	—	—	1.48	—	4	4
FPA-7	6.97	1.48	0.86	—	—	1.48	—	4	4
FPA-8	8.72	1.48	1.48	—	—	1.48	—	4	4
FPA-10	10.47	1.48	1.48	2.25	3.00	1.48	4.63	6	8
FPA-12	12.22	1.48	1.48	3.50	2.25	1.48	4.63	6	8
FPA-14	13.97	1.48	1.48	4.00	3.00	1.48	5.75	6	8

Material: 6061-T6 .125" aluminum
 Finish: Clear chromate conversion coating

Side Panel

Ordering Information

Ex: CSA-7X21
 (Side Panel for Chassis 7" Height and 21" Depth)

**Note, if application requires utility chassis to be rack mounted, additional holes will need to be added to side panels to accommodate slides.*

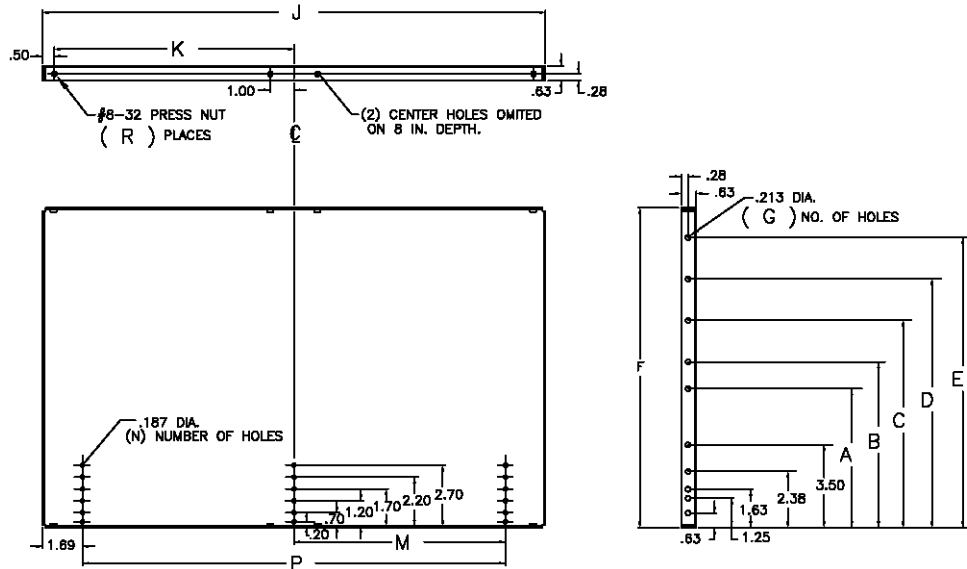

Height	A	B	C	D	E	F	G
CSA-3	—	—	—	—	—	3.00	8
CSA-5	—	—	—	—	—	4.75	10
CSA-7	5.88	—	—	—	—	6.50	12
CSA-8	5.88	7.00	—	—	—	8.25	14
CSA-10	5.88	7.00	8.75	—	—	10.00	16
CSA-12	5.88	7.00	8.75	10.50	—	11.75	18
CSA-14	5.88	7.00	8.75	10.50	12.25	13.50	20

Material: 5052-H32 .060" aluminum
 Finish: Clear chromate conversion coating

Depth	J	K	M	N	P	R
8	8.50	3.75	—	12	5.13	4
12	12.75	5.88	4.69	18	9.38	8
17	17.00	8.00	6.81	18	13.63	8
21	21.25	10.13	8.94	18	17.88	8

Chassis Plate

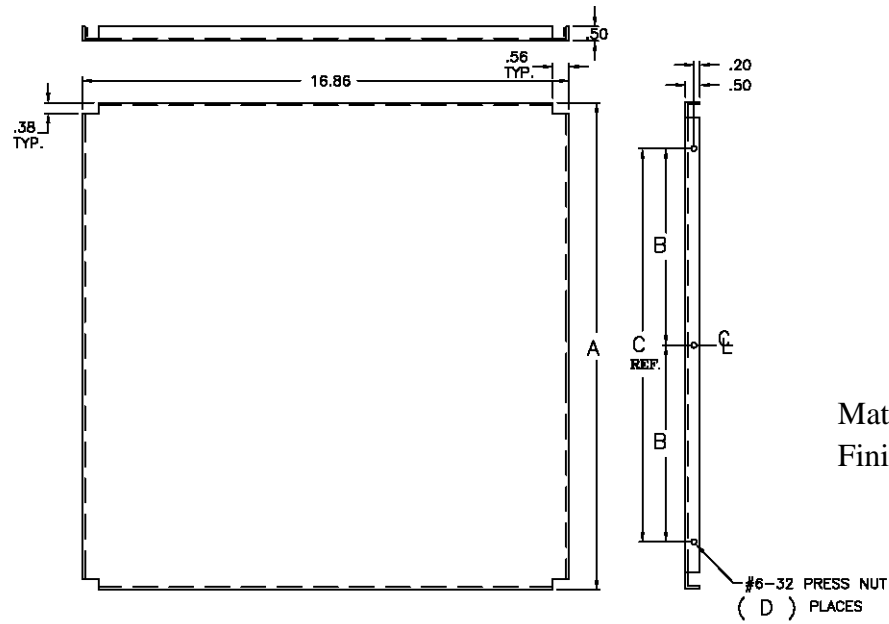

Catalog Number	A	B	C	D
SPA-8	8.36	—	5.13	4
SPA-12	12.61	4.69	9.38	6
SPA-17	16.86	6.81	13.63	6
SPA-21	21.11	8.94	17.88	6

Material: 5052-H32 .090" aluminum
Finish: Clear chromate conversion coating

Rear Support Panel

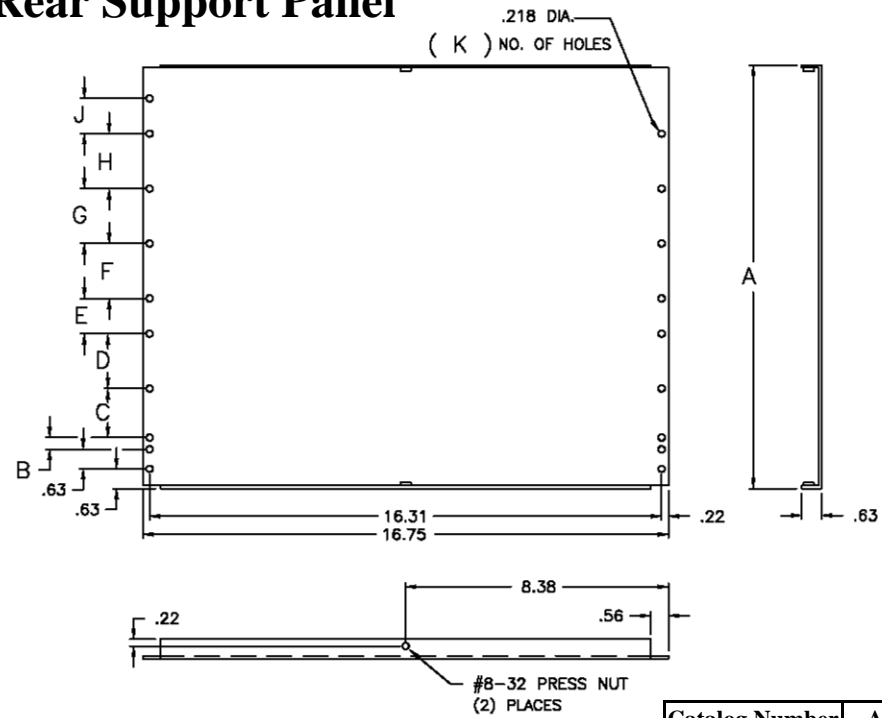

Material: 5052-H32 .090" aluminum
Finish: Clear chromate conversion coating

Catalog Number	A	B	C	D	E	F	G	H	J	K
RPA-3	3.00	0.38	0.75	—	—	—	—	—	—	8
RPA-5	4.75	0.38	0.75	1.12	—	—	—	—	—	10
RPA-7	6.50	0.38	0.75	1.12	2.38	—	—	—	—	12
RPA-8	8.25	0.38	0.75	1.12	2.38	1.12	—	—	—	14
RPA-10	10.00	0.38	0.75	1.12	2.38	1.12	1.75	—	—	16
RPA-12	11.75	0.38	0.75	1.12	2.38	1.12	1.75	1.75	—	18
RPA-14	13.50	0.38	0.75	1.12	2.38	1.12	1.75	1.75	1.75	20

Ventilated Protective Cover

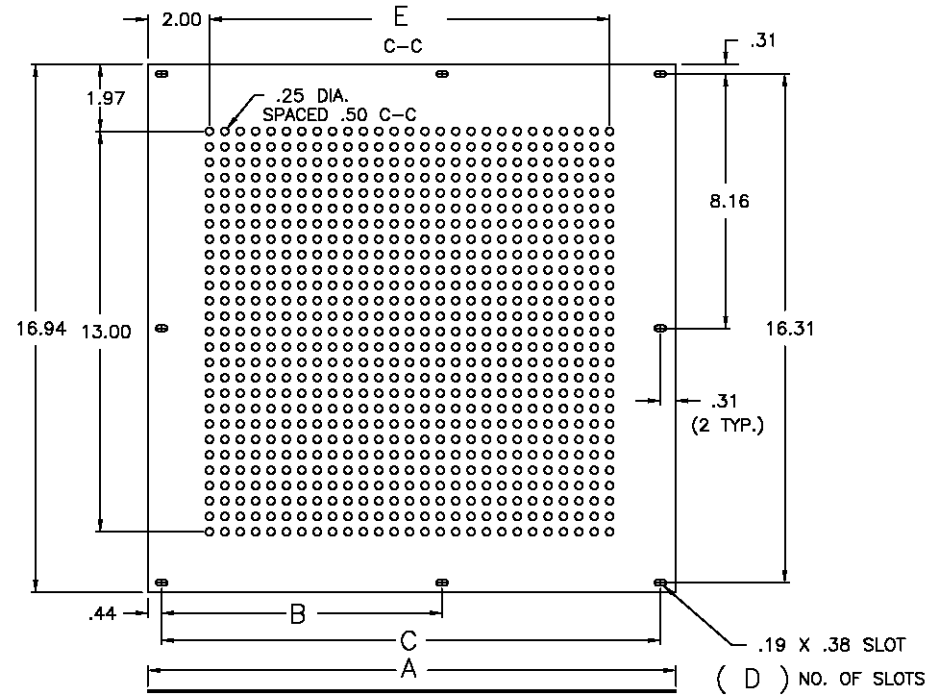

Catalog Number	A	B	C	D	E
PCA-8	8.44	—	7.50	6	5.00
PCA-12	12.69	6.88	11.75	8	8.00
PCA-17	16.94	9.00	16.00	8	13.00
PCA-21	21.19	11.13	20.25	8	17.00

Material: 5052-H32 .060" aluminum
 Finish: Clear chromate conversion coating

Solid Protective Cover

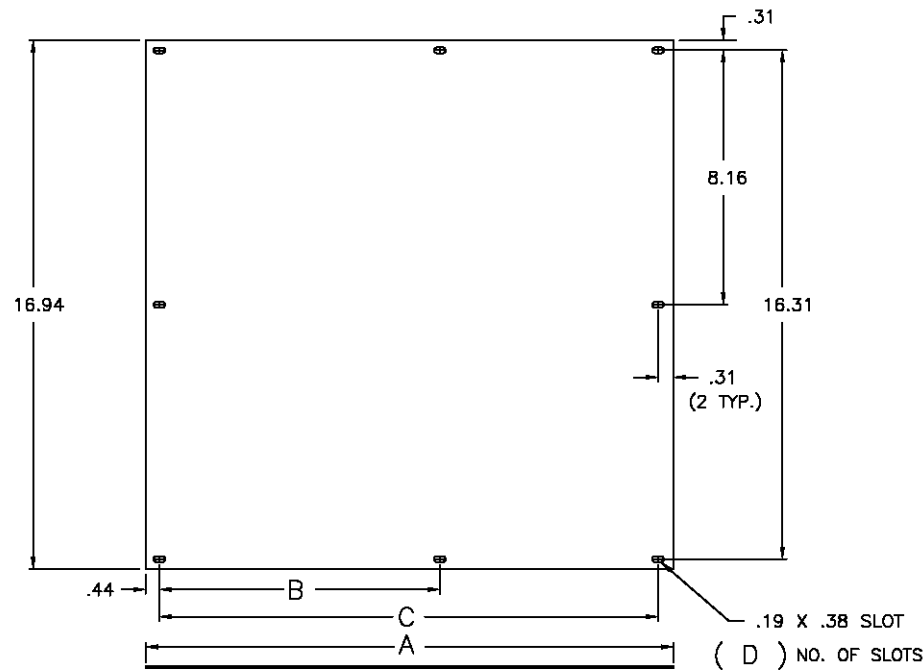

Catalog Number	A	B	C	D	E
PCA-8-S	8.44	—	7.50	6	5.00
PCA-12-S	12.69	6.88	11.75	8	8.00
PCA-17-S	16.94	9.00	16.00	8	13.00
PCA-21-S	21.19	11.13	20.25	8	17.00

Material: 5052-H32 .060" aluminum
 Finish: Clear chromate conversion coating

D-4021 Aluminum Blank Panels

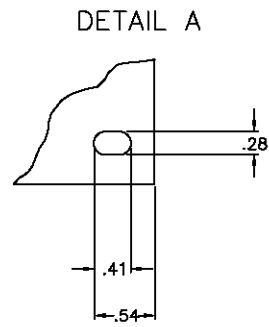
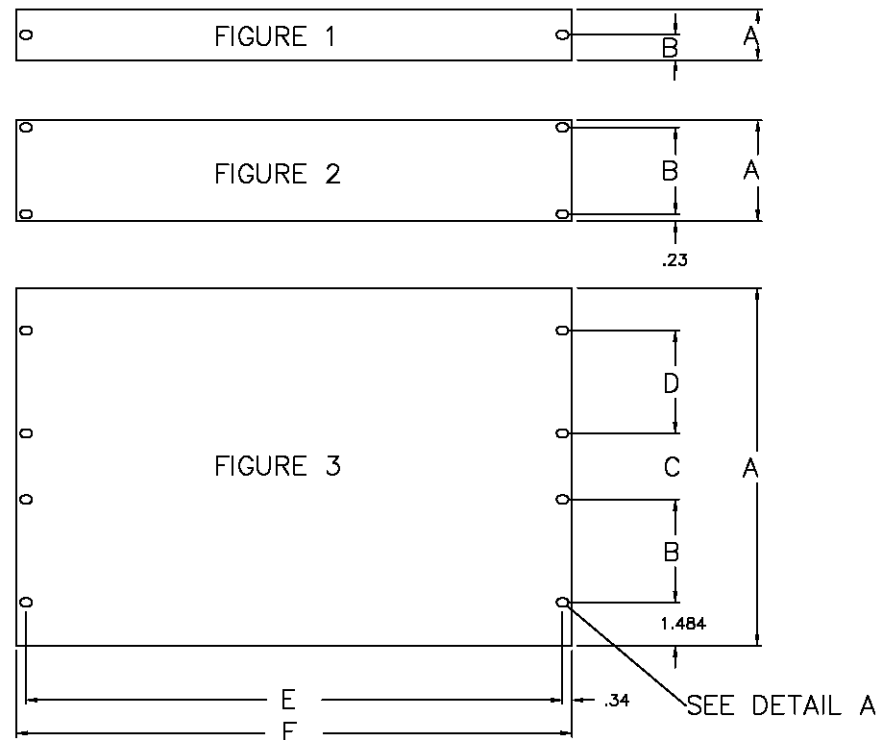

Standard material is 6061-T6 aluminum.

Standard finish: Clear chromate conversion coating.

Optional painting and punching to commercial or military specifications is available.

Ordering Information

VD4021 - XX - 00XX

Accessory Series

Panel Width		
Specify	E	F
0	18.31	19.0
2	23.31	24.0
3	29.31	30.0

Material Thickness	
Specify	For
0	0.13
1	0.19

Panel Height					
Specify	See Figure	A	B	C	D
01	1	1.72	0.86	—	—
03	2	3.47	3.00	—	—
05	3	5.22	2.25	—	—
07	3	6.97	4.00	—	—
08	3	8.72	5.75	—	—
10	3	10.47	2.25	3.00	2.25
12	3	12.22	3.50	2.25	3.50
14	3	13.97	4.00	3.00	4.00
15	3	15.72	4.00	4.75	4.00
17	3	17.47	4.00	6.50	4.00
19	3	19.22	5.25	5.75	5.25
21	3	20.97	5.25	7.50	5.25

D-329 Cable Carrier

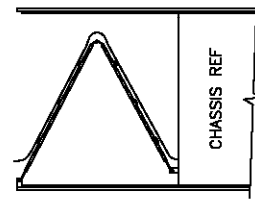
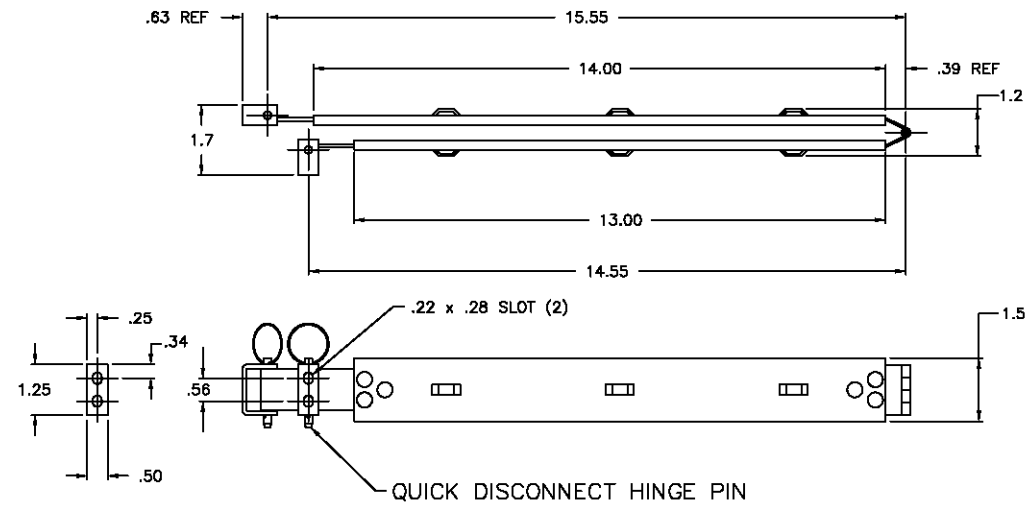

OPEN

Finish: Clear zinc commercial plating
 Material: C.R.S.
 Maximum extension: 30"
 To order, specify D-329

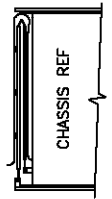

CLOSED

C-990 Cable Carrier

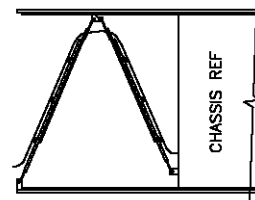
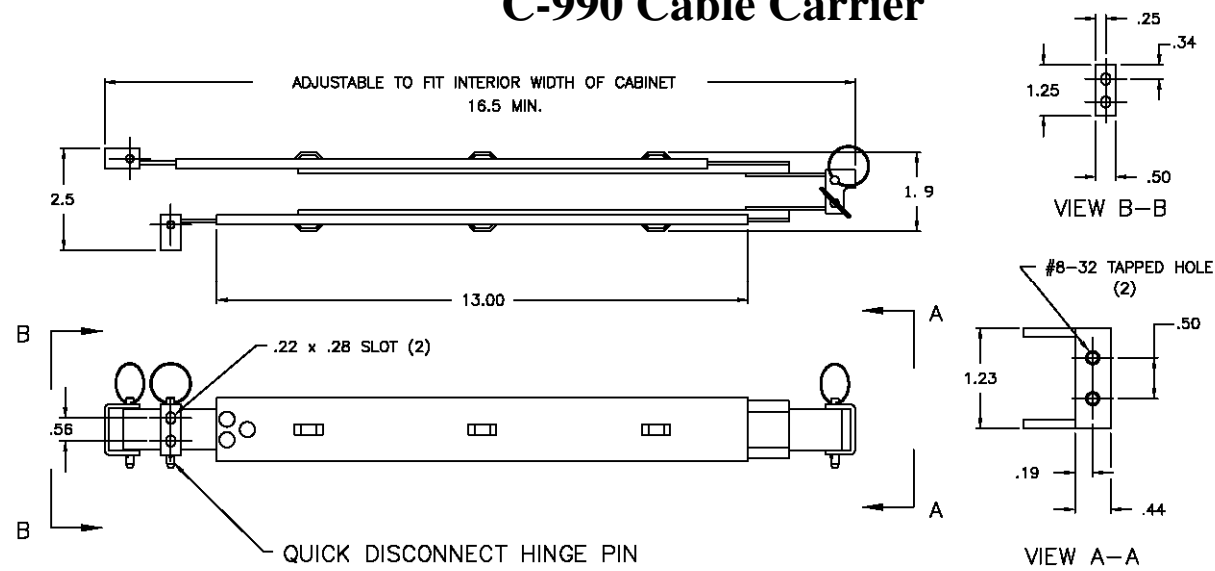

OPEN

Finish: Clear zinc commercial plating
 Material: C.R.S.
 Maximum extension: 30"
 To order, specify D-990

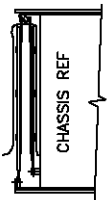

CLOSED

C-4555 Ribbon Cable Carrier

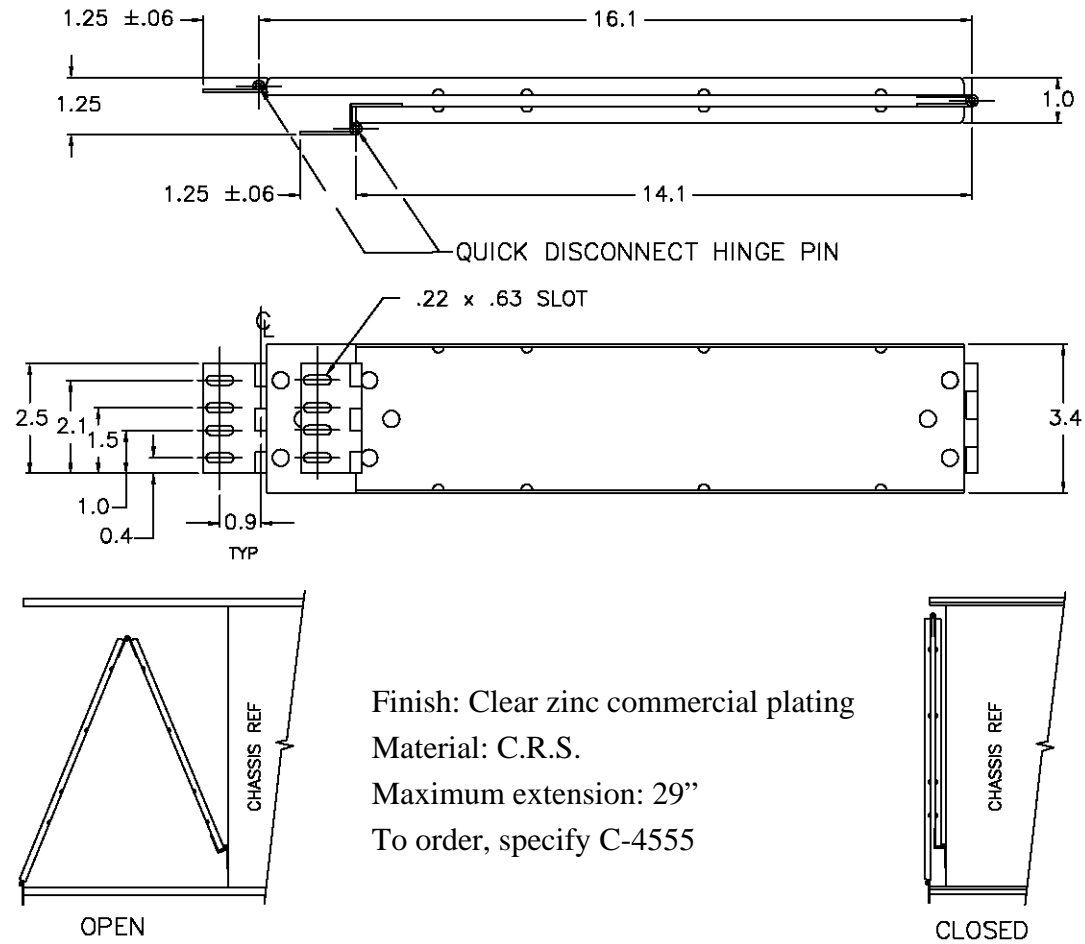

C-4017 Cable Roller Guide

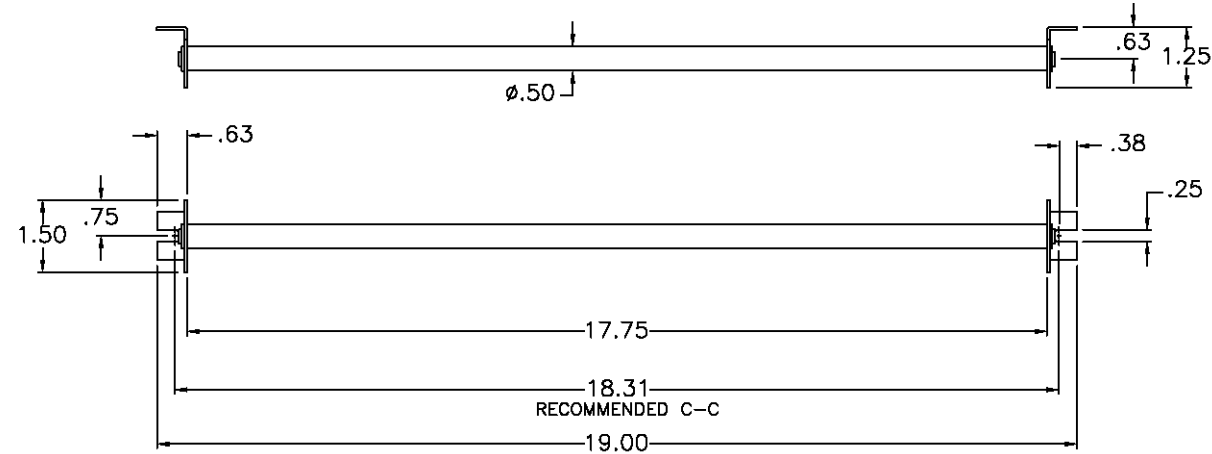

Finish: Clear zinc commercial plating
 Material: C.R.S.
 To order, specify C-4017
 May be used in conjunction with other
 cable carriers or retractors.

Cooling Devices



D-4118 Cooling Device

Finish: Front Panel is black
 To order, Specify D-4118
 See Next Page For Details

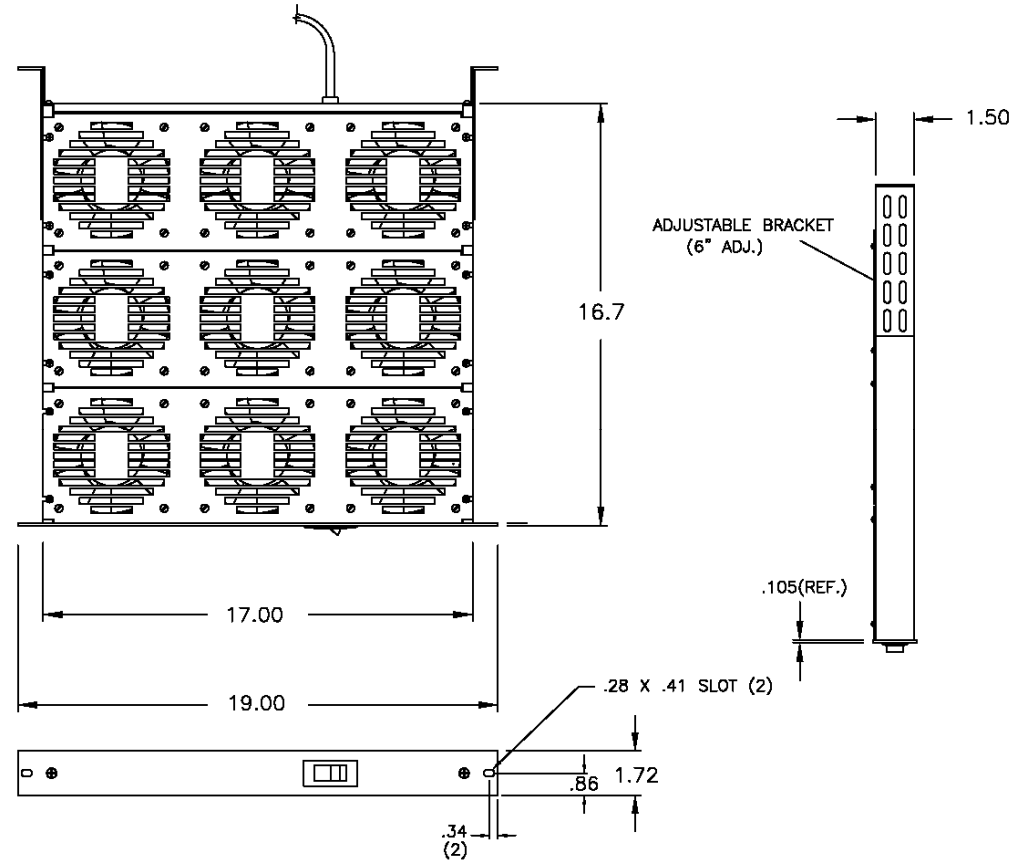

Ordering Information

VD4118 - XX - X,X,X,X,X - XXXXX

Accessory Series	
Specify	VD4121
	VD4118

Voltage	
Specify	For
10	110 VAC
20	220 VAC

To order 4118 or 4121 cooling device with slides (C-300-S-120/B-308 brackets), specify: 18S20
 *When ordering slides with a cooling device, a pull handle is supplied with the front panel.

Fan locations for VD4118: specify locations 1 thru 9. Model VD4121 supplied with 3 fans as standard. Fans are 100 C.F.M. (each).

Example: VD4118-10-1,3,5-18S20

D-4119 Cooling Devices

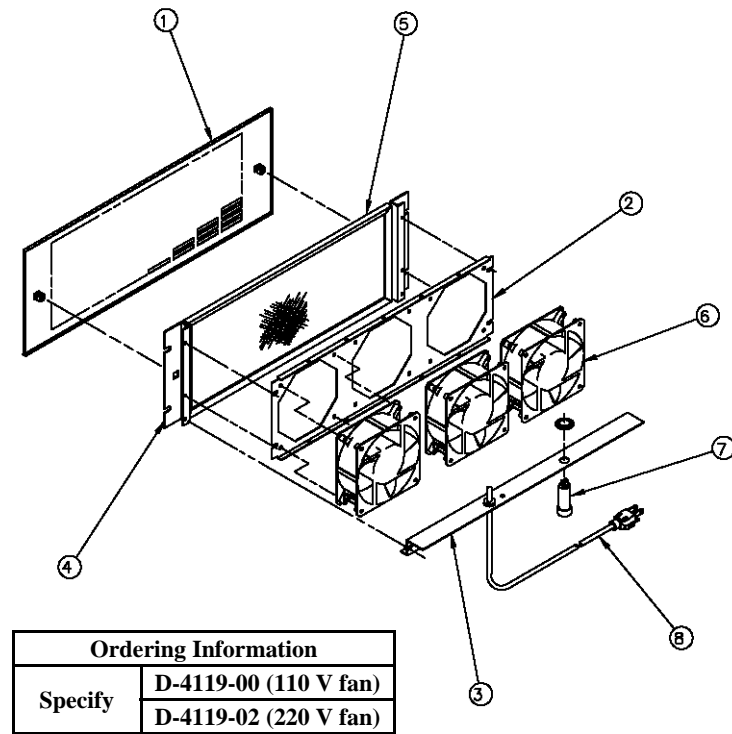

1. Removable front vent panel (20 gauge stainless steel).
2. Fan mount (18 gauge C.R.S.; Finish: Clear zinc commercial plating).
3. Wire support bracket (16 gauge C.R.S.; Finish: Clear zinc commercial plating).
4. Filter bracket (2 each; 14 gauge C.R.S.; Finish: Clear zinc commercial plating).
5. Washable filter.
6. Fan (3 each; 100 C.F.M. rating).
7. 1.5 AMP. Circuit breaker.

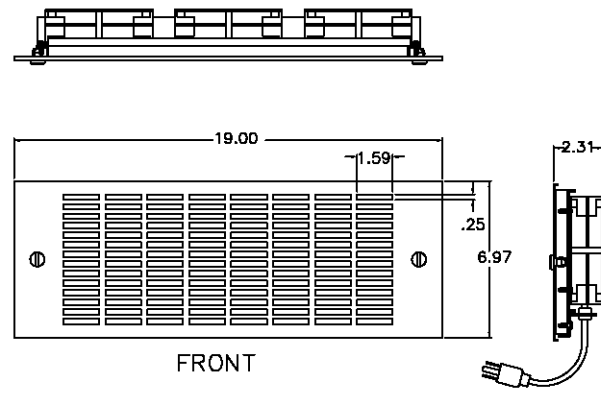

Ordering Information	
Specify	D-4119-00 (110 V fan)
	D-4119-02 (220 V fan)

D-4121 Cooling Device

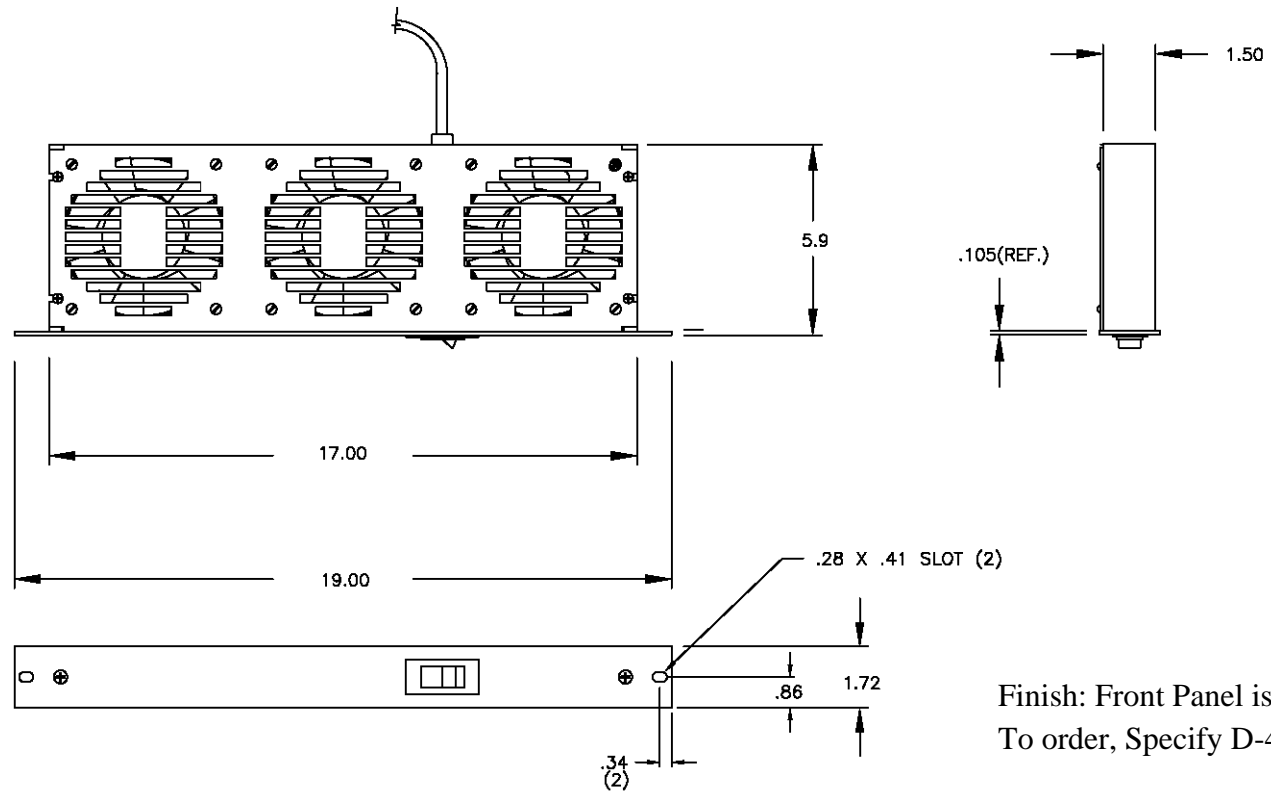

Finish: Front Panel is black
To order, Specify D-4121

Cabinets and Racks

General Devices offers a selection of electronic cabinets and racks for use in the broadcast and telecommunication industries.

- 2500 Floor Mounted Relay Rack
- 2600 Floor/Caster Mounted Relay Rack
- 6200 Medium Duty Commercial Cabinet

All cabinets and racks can be customized to match customer supplied specifications.

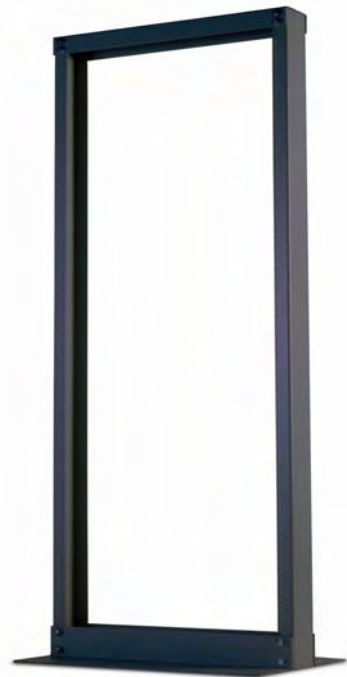

2500 Relay Rack



Knock-Down Floor Mounted Relay Rack

The 2500 Relay Rack is a perfect compliment to the 6200 Rack. Ideal for monitors, video editors, power supplies, tape machines and more.

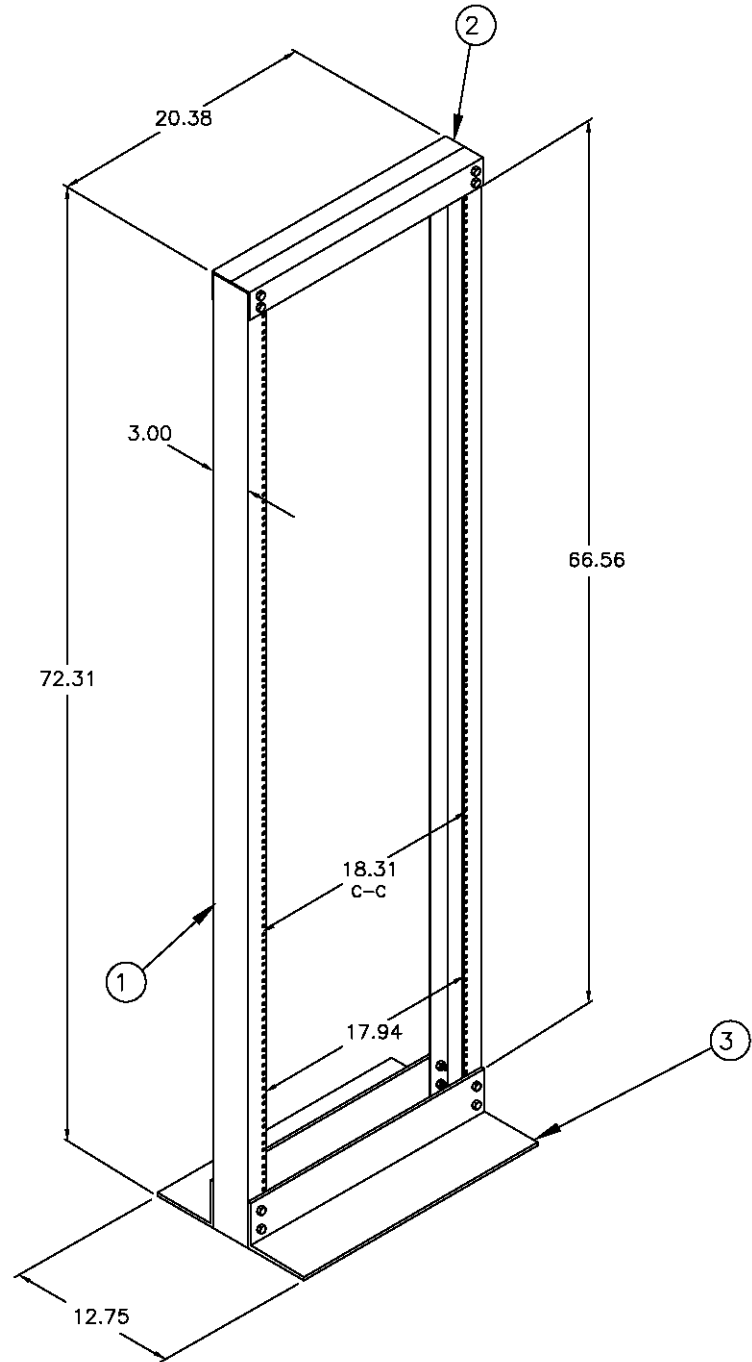
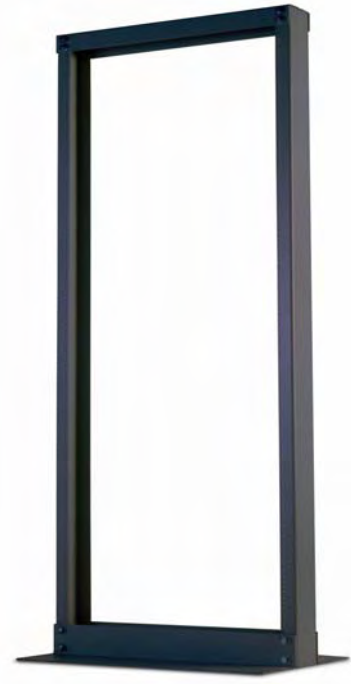

Notes

1. Uprights (1 pair) made from 10 gauge C.R.S. with #10-32 tapped holes per EIA RS-310 specs. On 18.31" center to center.
2. Two cross bars (10 gauge C.R.S.)
3. Two base plates (7 gauge C.R.S.)
4. Finish: Painted standard #26440 gray.
5. Model 2500 is shipped unassembled.

2600 Relay Rack



Knock-Down Floor/Caster Mounted



The 2600 Relay Rack is a perfect compliment to the 6200 Rack. Ideal for monitors, video editors, power supplies, tape machines and more. The 2600 is also available with optional casters.

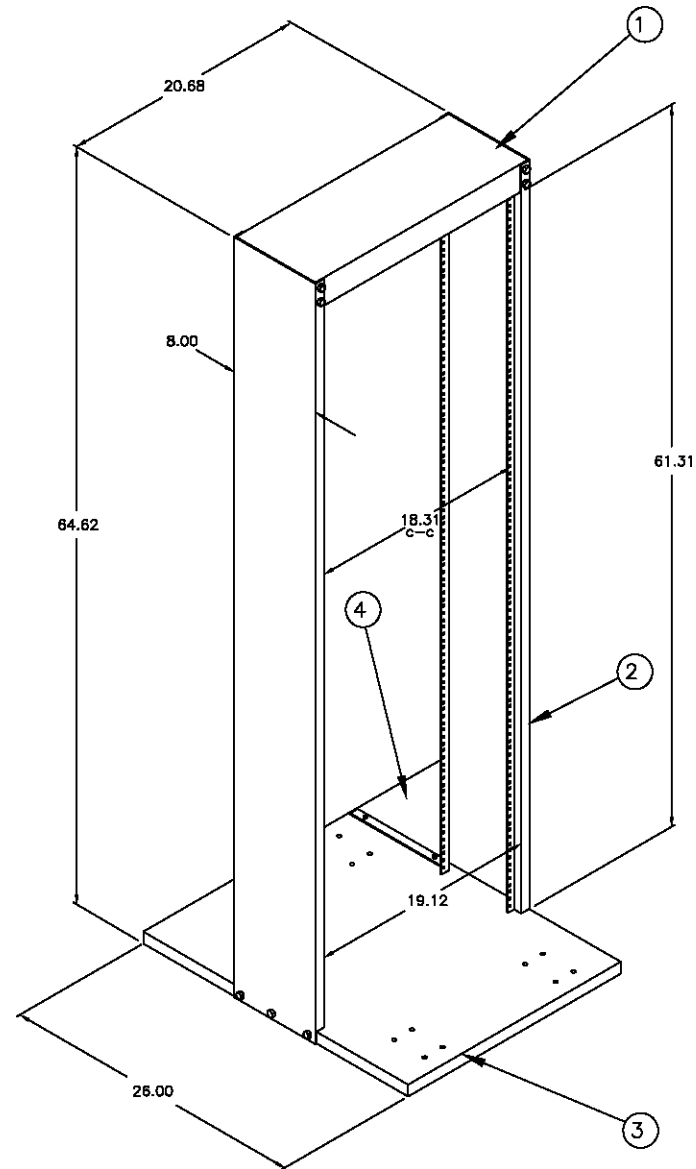

Notes

1. Cap is made of 12 gauge C.R.S.
2. Uprights (1 pair) made from 12 gauge C.R.S. with #10-32 tapped holes per EIA RS-310 specs. on 18.31" center to center.
3. Base weldment (12 gauge C.R.S.)
4. Two Gussets (12 gauge C.R.S.)
5. Finish: Painted standard #26440 gray.
6. Model 2600 is shipped unassembled.
7. Optional casters (set of 4) are available.

6200 Cabinet

Medium Duty Commercial Cabinet



The 6200 line of cabinets is a favorite of leading companies in the electronics and communications industries. This versatile enclosure is designed and built to pass some of the most stringent commercial applications. The 6200 provides strength, versatility, quality and attractive appearance at a very affordable price.

(Optional front door shown)

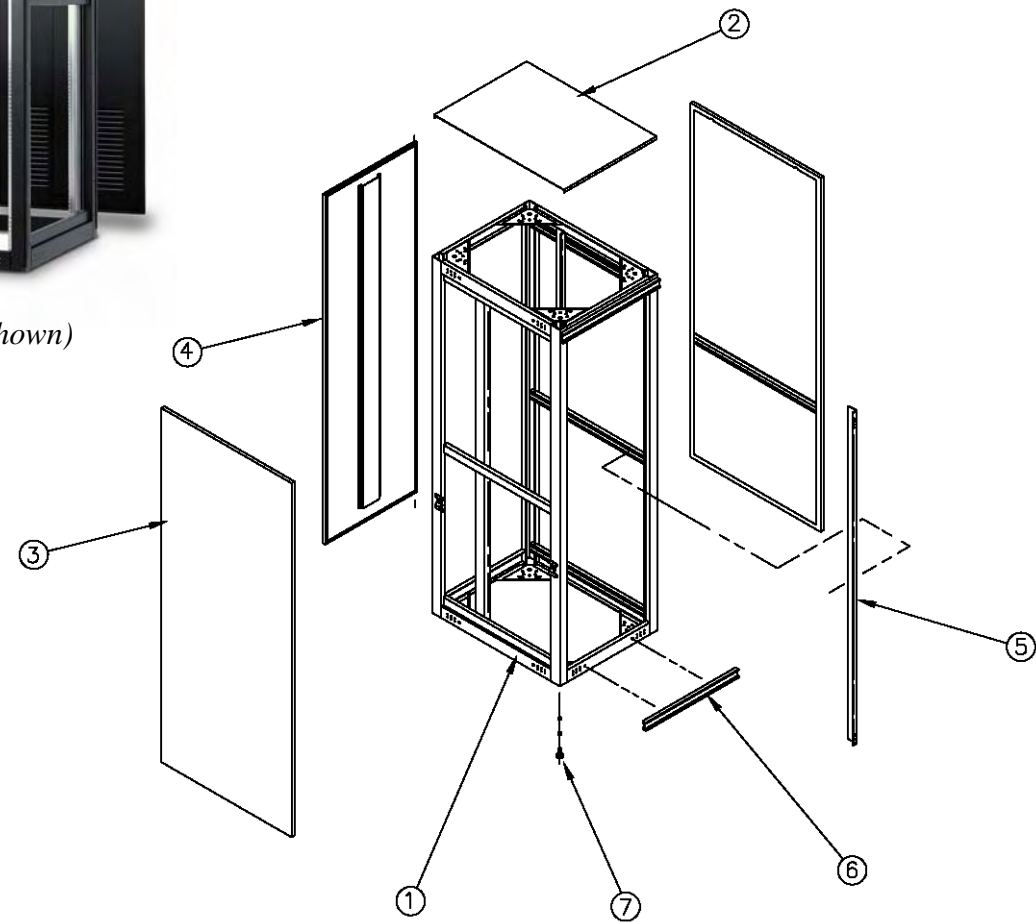

Notes

1. Cabinet Frame is made from 12 gauge C.R.S.
 2. Removable top cover is made from 12 gauge C.R.S.
 3. Removable side panel (lift-off, 2 each) is made from 18 gauge C.R.S.
 4. Removable rear door (16 gauge C.R.S.)
 5. Mounting angles (2 pair) are made from 12 gauge C.R.S. with #10-32 tapped holes per EIA RS-310 specs. Finish: Zinc and bright
 6. Decorative front horizontal trim (2 each)
 7. Leveler assembly (4 each)
- Standard cabinet includes all items shown

6200 Cabinet

Medium Duty Commercial Cabinet

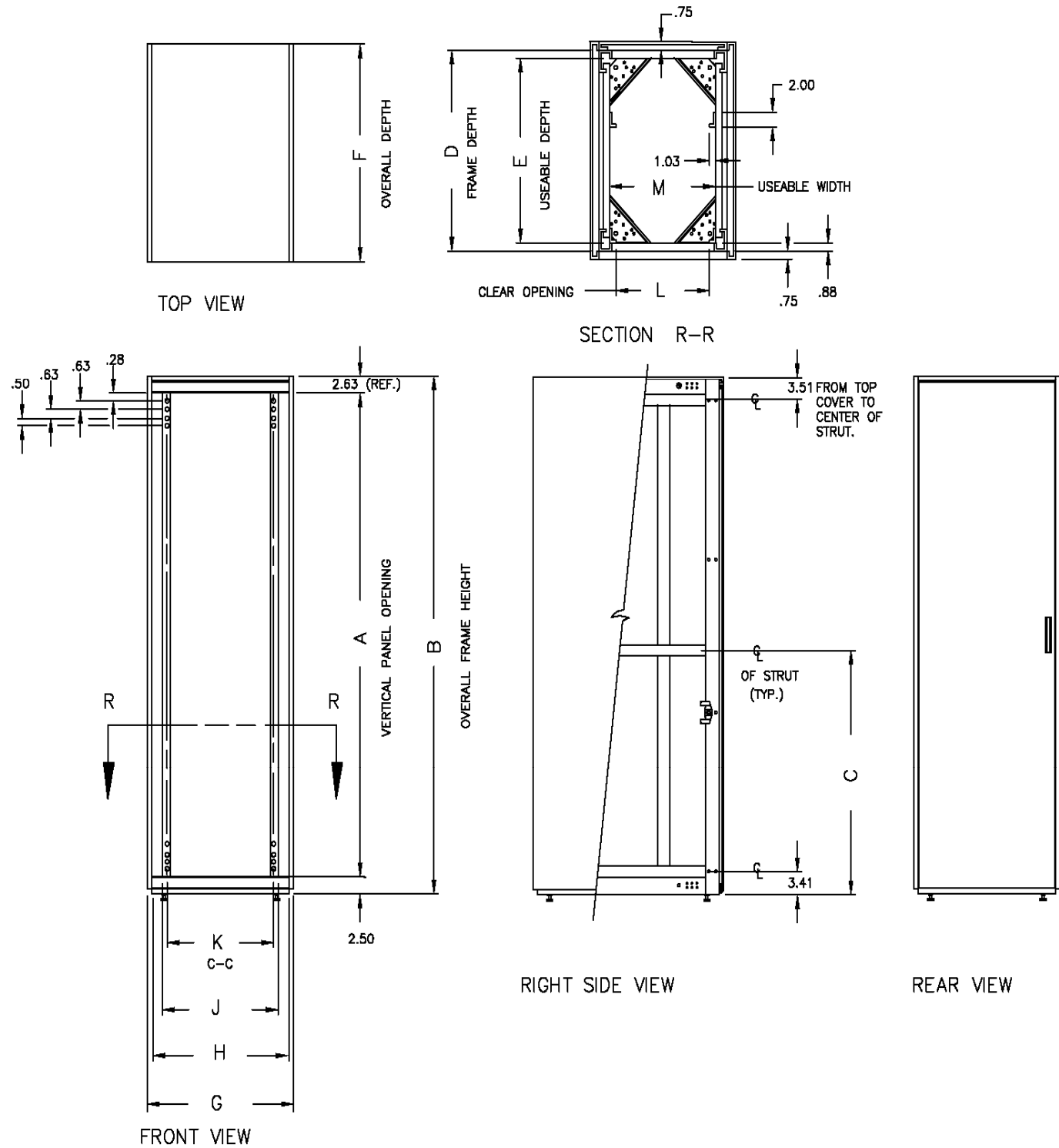

Available Standard Powder Coat Paint Colors

- A) Black
- B) Light Gray
- C) Light Blue
- D) IBM Cloud White
- E) IBM Charcoal Gray
- F) IBM Sky Blue

Additional colors and Federal Standard Color Matching also available.

6200 Cabinet



Medium Duty Commercial Cabinet

ORDERING INFORMATION

VR6200 - XX - XX - XX - XX - XXXX - XXXXX

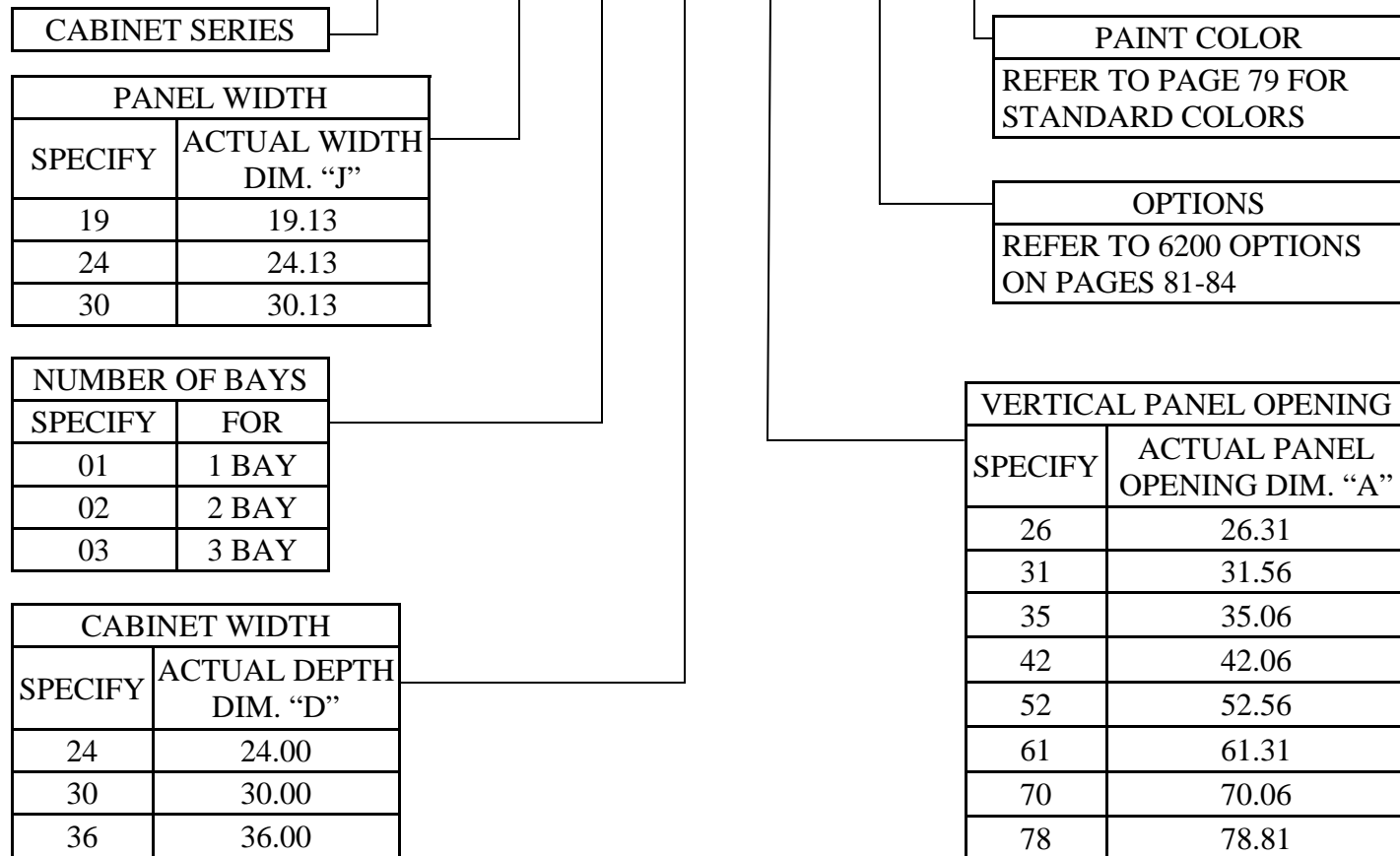

CABINET SERIES

PANEL WIDTH	
SPECIFY	ACTUAL WIDTH DIM. "J"
19	19.13
24	24.13
30	30.13

PAINT COLOR
REFER TO PAGE 79 FOR STANDARD COLORS

OPTIONS
REFER TO 6200 OPTIONS ON PAGES 81-84

NUMBER OF BAYS	
SPECIFY	FOR
01	1 BAY
02	2 BAY
03	3 BAY

VERTICAL PANEL OPENING	
SPECIFY	ACTUAL PANEL OPENING DIM. "A"
26	26.31
31	31.56
35	35.06
42	42.06
52	52.56
61	61.31
70	70.06
78	78.81

CABINET WIDTH	
SPECIFY	ACTUAL DEPTH DIM. "D"
24	24.00
30	30.00
36	36.00

Panel Width

Order Width	Overall Width G	Frame Width H	Panel Width J	Hole C-C K	Clear Opening L	Useable Width M
19	24.13	22.63	19.13	18.31	17.94	20.00
24	29.13	27.63	24.13	23.31	22.94	25.00
30	35.13	33.63	30.13	29.31	28.94	31.00

Cabinet Depth

Order Depth	Frame Depth D	Usable Depth E	Overall Depth F
24	24.00	22.25	25.50
30	30.00	28.25	31.50
36	36.00	34.25	37.50

Vertical Panel Opening

Order P.O.	Panel Opening A	Overall Height B	Strut Location C
26	26.31	31.44	—
31	31.56	36.69	—
35	35.06	40.19	—
42	42.06	47.19	21.38
52	52.56	57.69	26.63
61	61.31	66.44	31.00
70	70.06	75.19	35.38
78	78.81	83.94	39.75

EXAMPLE: VR6200-19-30-70-62LSPT, 62CBMD-27038

6200 Cabinet Options



Medium Duty Commercial Cabinet

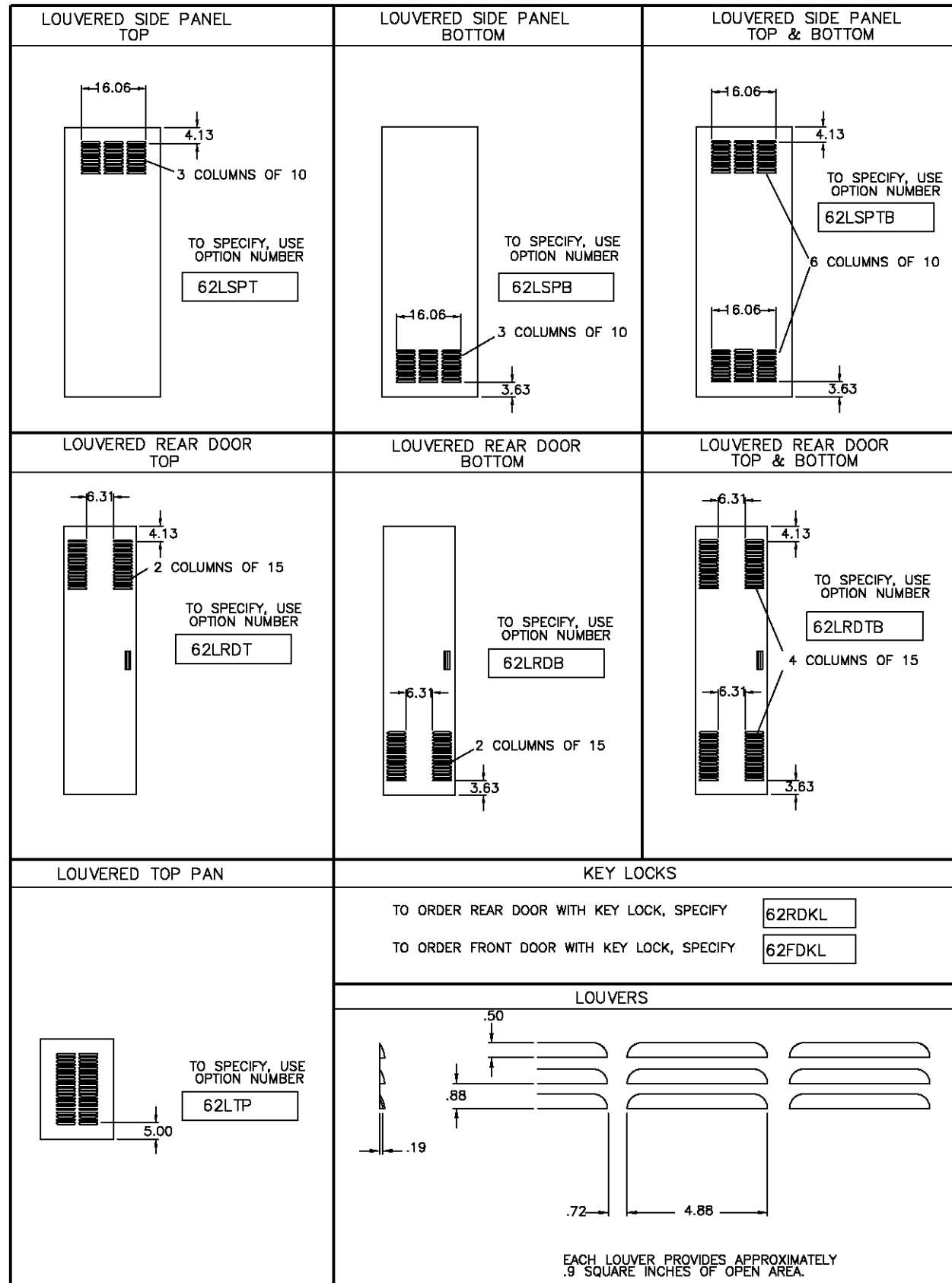

6200 Cabinet Options

Medium Duty Commercial Cabinet



<p>CASTER BASE – TOP VIEW</p> <p>SEE CHART ON PAGE 80 FOR DIMENSIONS "D" & "H"</p>	<p>STANDARD DUTY CASTERS</p> <p>2" DIA, 150 LB CAPACITY DUAL WHEEL SWIVEL CASTERS TO SPECIFY, USE OPTION NUMBER</p> <p>62CSD</p>
<p>STANDARD DUTY CASTER BASE</p> <p>2" DIA, 150 LB CAPACITY DUAL WHEEL SWIVEL CASTERS TO SPECIFY, USE OPTION NUMBER</p> <p>62CBSD</p>	<p>MEDIUM DUTY CASTERS</p> <p>4" DIA, 200 LB CAPACITY CASTERS FRONT SWIVEL, REAR RIGID TO SPECIFY, USE OPTION NUMBER</p> <p>62CMD</p> <p>TO SPECIFY ALL SWIVEL CASTERS USE OPTION NUMBER</p> <p>62CMDS</p>
<p>MEDIUM DUTY CASTER BASE</p> <p>4" DIA, 200 LB CAPACITY CASTERS FRONT SWIVEL, REAR RIGID TO SPECIFY, USE OPTION NUMBER</p> <p>62CBMD</p> <p>TO SPECIFY ALL SWIVEL CASTERS USE OPTION NUMBER</p> <p>62CBMDS</p>	<p>HEAVY DUTY CASTERS</p> <p>4" DIA, 300 LB CAPACITY CASTERS FRONT SWIVEL, REAR RIGID TO SPECIFY, USE OPTION NUMBER</p> <p>62CHD</p> <p>TO SPECIFY ALL SWIVEL CASTERS USE OPTION NUMBER</p> <p>62CHDS</p>
<p>HEAVY DUTY CASTER BASE</p> <p>FRONT SWIVEL, REAR RIGID 4" DIA, 300 LB CAPACITY CASTERS TO SPECIFY, USE OPTION NUMBER</p> <p>62CBHD</p> <p>TO SPECIFY ALL SWIVEL CASTERS USE OPTION NUMBER</p> <p>62CBHDS</p>	<p>STATIONARY BASE</p> <p>TO SPECIFY, USE OPTION NUMBER</p> <p>62SB</p>

6200 Cabinet Options



Medium Duty Commercial Cabinet

<p>STANDARD MOUNTING ANGLE</p> <p>TO SPECIFY, USE OPTION NUMBER 62MA</p> <p>TWO PAIR OF MOUNTING ANGLES ARE PROVIDED WITH THE CABINET UNLESS OTHERWISE SPECIFIED.</p> <p>TO ORDER ADDITIONAL MOUNTING ANGLES, WRITE THE OPTION NUMBER TIMES THE NUMBER OF PAIR DESIRED.</p> <p>EXAMPLE: 62MA X 2</p>	<p>OFFSET MOUNTING CHANNEL</p> <p>TO SPECIFY, USE OPTION NUMBER 62OMC</p> <p>TO REPLACE THE STANDARD MOUNTING ANGLES WITH MOUNTING CHANNELS, PLACE "R" IN FRONT OF THE OPTION NUMBER.</p> <p>EXAMPLE: R62OMC</p> <p>TO ORDER MOUNTING CHANNELS IN ADDITION TO MOUNTING ANGLES, WRITE THE OPTION NUMBER TIMES THE NUMBER OF PAIR DESIRED.</p> <p>EXAMPLE: 62OMC X 2</p>
<p>MOUNTING "Z" RAIL</p> <p>TO SPECIFY, USE OPTION NUMBER 62MZR</p> <p>TO REPLACE THE STANDARD MOUNTING ANGLES WITH MOUNTING "Z" RAILS, PLACE "R" IN FRONT OF THE OPTION NUMBER.</p> <p>EXAMPLE: R62MZR</p> <p>TO ORDER MOUNTING RAILS IN ADDITION TO THE MOUNTING ANGLES, WRITE THE OPTION NUMBER TIMES THE NUMBER OF PAIR DESIRED.</p> <p>EXAMPLE: 62MZR X 2</p>	<p>MOUNTING CHANNEL</p> <p>TO SPECIFY, USE OPTION NUMBER 62MC</p> <p>TO REPLACE THE STANDARD MOUNTING ANGLES WITH MOUNTING CHANNELS, PLACE "R" IN FRONT OF THE OPTION NUMBER.</p> <p>EXAMPLE: R62MC</p> <p>TO ORDER MOUNTING CHANNELS IN ADDITION TO MOUNTING ANGLES, WRITE THE OPTION NUMBER TIMES THE NUMBER OF PAIR DESIRED.</p> <p>EXAMPLE: 62MC X 2</p>
<p>FRONT DOOR OPTIONS</p> <p>TOP VIEW</p> <p>FRONT</p> <p>62GFD</p> <p>PLEXIGLAS® COLOR NO. 2094 GRAY WILL BE USED UNLESS OTHERWISE SPECIFIED.</p> <p>FRONT</p> <p>TO ORDER SOLID STEEL FRONT DOOR, SPECIFY</p> <p>62SFD</p>	<p>BOTTOM COVER</p> <p>TO SPECIFY, USE OPTION NUMBER</p> <p>62BC</p> <p>.10</p>

6200 Cabinet Options



Medium Duty Commercial Cabinet

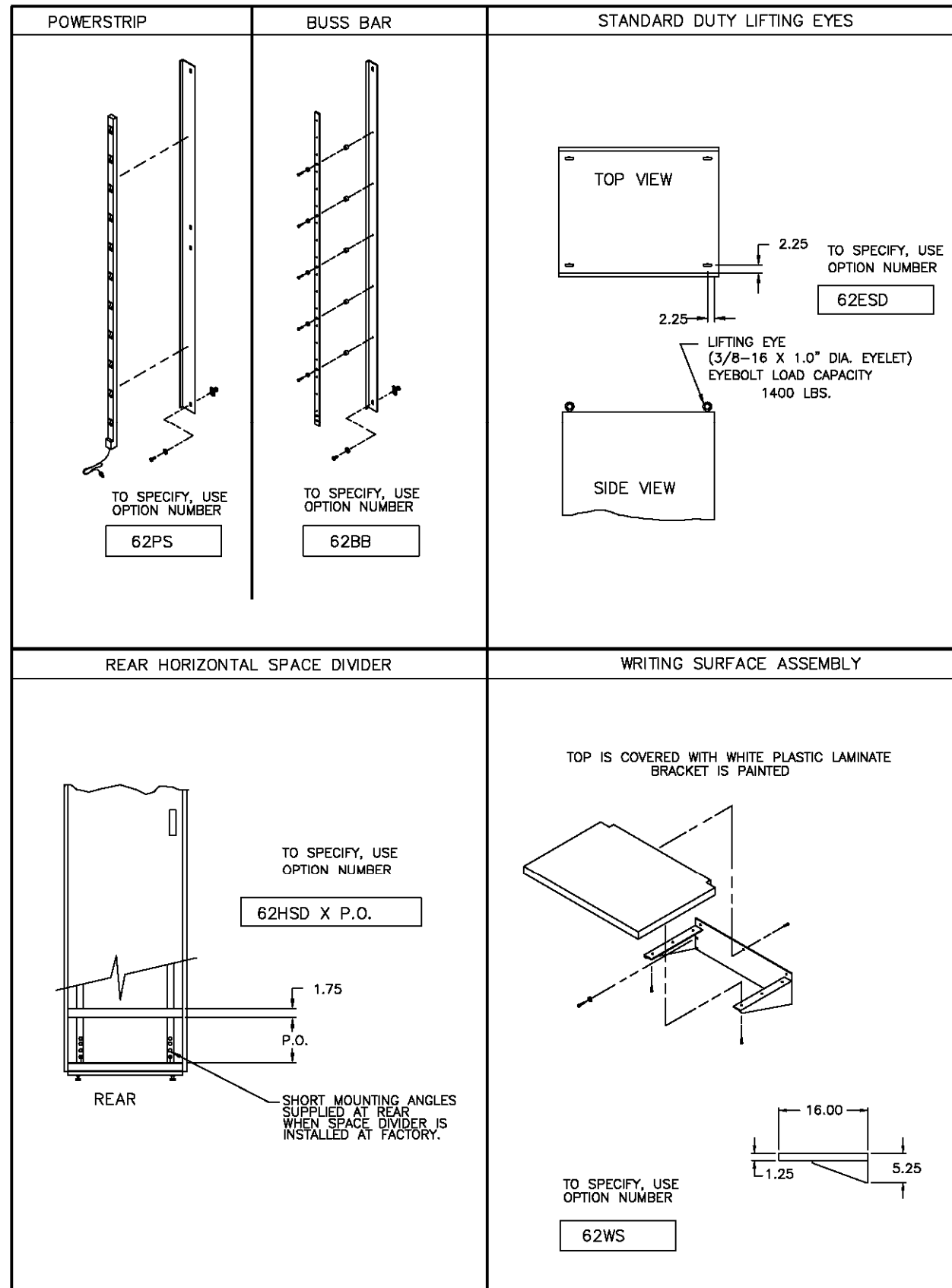

Multipurpose Shelter



General Devices Multipurpose Communication Shelters are constructed of powder-coated steel and insulated for maximum weatherability requiring minimal maintenance. Protect your equipment with one of our temperature controlled environment options: air conditioning, baseboard heat or forced air.

Benefits/Features

- Tough and resilient
- Costs less than concrete or fiberglass
- Light enough to be portable - can be site located by forklift or boom
- Locate on any firm, level surface - no site foundation required
- Strength, security and durability of steel
- Weatherproof
- Work inside, not outside
- Locks from the outside for security
- Power, cable, and utility access through floor



Optional wall mounted air conditioners, emergency generator connection system, and special hinged satellite dish mounting platform shown.

Available Options

- Baseboard heater and/or window or wall unit air conditioner with thermostat
- Exhaust fan with thermostat
- 19-inch equipment rack & relay rack configurations
- Overhead cable racks
- Emergency generator connection system

Mechanical Specifications

Product Code	Width	Depth	Height	Shipping Weight
MCS667	77 in (195 cm)	72 in (183 cm)	86 in (218 cm)	1800+
MCS669	77 in (195 cm)	72 in (183 cm)	104 in (264 cm)	2200+
MCS697	77 in (195 cm)	108 in (274 cm)	86 in (218 cm)	2400+
MCS699	77 in (195 cm)	108 in (274 cm)	104 in (264 cm)	2900+
MCS8129	96 in (244 cm)	144 in (366 cm)	104 in (264 cm)	4400+

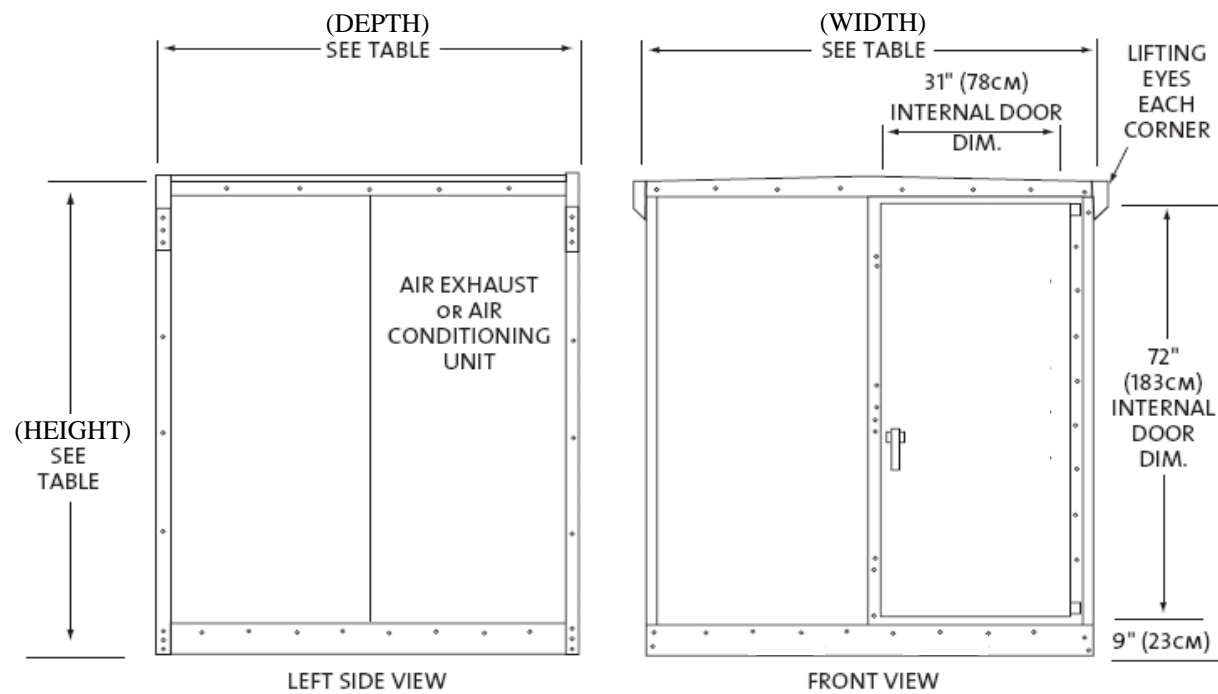

Walls, Floor and Ceiling

Powder-coated steel with insulation

Door

Dimensions: 31" X 72"
Shipped with three-point locking handle and eye for padlock

Bases

Forklift accessible

Ventilation Panels

With fan and timer

Shelter Interior

White melamine walls

Lighting Kit

Fluorescent light and wall receptacles

Hardware Kit

Stainless steel anchor brackets

Equipment to Meet Your Needs

Whether you need engineering input on a custom metal product, precision cutting for a single prototype, or high-production stamping and finishing, your best source for complete sheet metal fabrication services is General Devices Company.



Laser Capabilities

- Ideal for precision-cut short runs and prototypes where fast turnaround is important.
- Maintains tight cutting tolerances and excellent high edge quality results.
- Table capacities of up to 5' x 10'.
- Cuts up to 1/2" of steel.
- Complex pattern capability.



CNC Turret Presses

Most efficient choice for jobs requiring standard hole sizes or a large number of holes per sheet.

Hard Tooling and Die Shop

An on site Tool and Die shop that designs, builds, and maintains dies, fixtures, weld fixtures, and inspection gauges.

Screw Machine Shop

Small – and medium-run production of special fasteners, screws, washers and more. Capable of creating custom hardware from nylon, steel, aluminum, and stainless with up to 2 1/4" capacity.

Manufacturing Capabilities and Resources

General Devices manufacturing resources include:

- Traditional punch presses and modern stamping dies
 - Stampings up to 500 tons
- Lathes, Saws, Rivet Machines and Orbital Rivet Machines
- Shears, Screw Machines
- Welding, including:
 - GMAW, (Gas Metal-Arc Welding)
 - Bench
 - Robotic
 - GTAW (Gas Tungsten-Arc Welding)
 - RSW (Resistance Spot Welding)
- Surface Grinders
- Zinc Plating System
- Comprehensive Powder Coat Paint and Finish Capabilities
- Silk-screening
- Many other custom coatings and finishes are available.

Please contact the factory for your requirements.

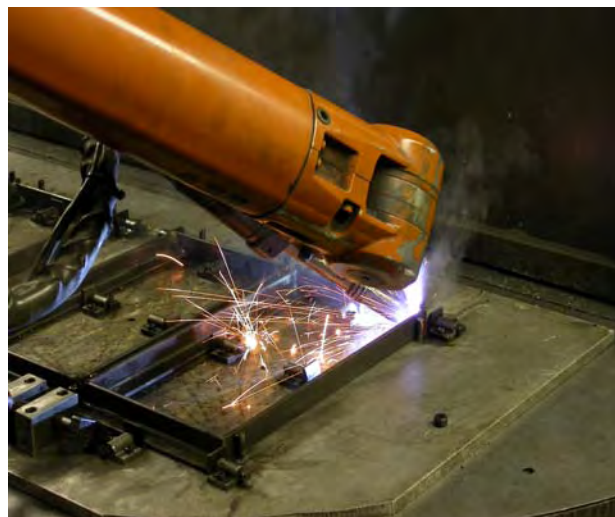



CUSTOM METAL FABRICATION



MULTIPURPOSE SHELTERS

CABINETS AND RACKS



BOTTOM MOUNT SLIDES



BALL BEARING SLIDES



CABINET ACCESSORIES



317-897-7000
sales@generaldevices.com
www.generaldevices.com



PRODUCT CATALOG

Choose from the most complete selection of standard and custom slides, cabinets and racks available.

CHASSIS TRAK®
Telescopic Slides

VENT RAK®
Cabinets & Enclosures



General Devices Company
P.O. Box 39100
1410 S. Post Road
Indianapolis, IN 46239-0100
USA
Phone: 317-897-7000
Fax: 317-898-2917

X-ON Electronics

Largest Supplier of Electrical and Electronic Components

Click to view similar products for [general devices manufacturer](#):

Other Similar products are found below :

[C-300-S-116](#) [CLB-305-20](#) [CTRS-112](#) [CM5](#) [C-938-28-LI/LO](#) [C-874-28](#) [C-874-22](#) [CTHS-124](#) [CTRS-124](#) [CM14](#) [C-230-S-116](#) [C-938-12](#) [C-938-20-LI-LO](#) [D-4455](#) [CM3](#) [CLB-203-22](#) [C-3700-18](#) [CLB-203-20](#) [CTS-122](#) [CLB-203-28](#) [CLB-203-24](#) [D-4454-19X24](#) [D-4080-1](#) [PCA-17](#) [B-217-2.5](#) [C-230-S-122](#) [D-4456](#) [C-300-S-120-RC-3S](#) [B-810-2](#) [C-300-S-118-RC](#) [B-793](#) [PCA-21](#) [B-307-1](#) [C-300-S-128](#) [C-300-S-126-RC](#) [C-300-S-210](#) [C-300-S-424](#) [C-4555](#) [C-300-S-122-RC-3S](#) [C-300-S-120-RC](#) [C-4017](#) [CTS-120](#) [C-300-S-424-RC-3S](#) [B-217-2](#) [B-131-3.5](#) [B-307-2](#) [C-300-S-422](#) [C-230-S-124](#) [C-300-S-420](#) [C-300-S-124](#)