

# **FLAT PAK I/O MODULE SELECTION GUIDE**

---

## **5 Volt Logic Voltage Only**

### **AC INPUT**

12 - 32 VAC	IDC5P
90 - 140 VAC	IAC5P

### **AC OUTPUT**

12 - 140 VAC	OAC5P
--------------	-------

### **DC INPUT**

10 - 32 VDC	IDC5P
90 - 140 VDC	IAC5P

### **DC OUTPUT**

5 - 60 VDC	ODC5P
------------	-------

# AC INPUT MODULES FLAT PAK, PLUG-IN

12 - 32 VAC  
90 - 140 VAC

## DESCRIPTION

The Flat Pak AC input modules are used for sensing ON/OFF alternating current (AC) voltage levels. All AC input modules are designed with filtering on the input and a hysteresis amplifier for high noise rejection and transient free "clean" switching. Each module provides up to 4000  $V_{rms}$  of optical isolation between the field inputs and the logic side of the circuit.

The Flat Pak module are typical used on user-designed printed circuit boards where the standard single channel or Quad Pak module do not provide an exact fit. The Flat Pak modules are also ideal for circuit boards designed for computer chassis (i.e., Intel's MultiBus, STD bus, etc.) because of its low profile.

Typical uses and applications include sensing the presence or absence of voltage or sensing contact closures from sources such as:

- Proximity Switches
- Limit Switches
- Selector Switches
- Push Button And Toggle Switches
- Thermostats

## FEATURES

- Industry standard plug-in module
- 4000 VAC optical isolation
- UL recognized #E58169
- CSA certified #35852
- Operating temperature: -30 to 70° C
- Built-in filtering for transient suppression and noise rejection

## ORDERING GUIDE

Input Voltage VAC	Logic Voltage	Part Number
12 - 32	5	IDC5
90 - 140	5	IAC5

**AC INPUT MODULES  
FLAT PAK, PLUG-IN**

**12 - 32 VAC  
90 - 140 VAC**

**SPECIFICATIONS**

**GENERAL - Applies To All Models**

Operating Ambient Temperature: -30 to 70° C  
 Isolation Input-To-Output: 4000 V<sub>rms</sub>  
 Output Voltage Drop: 0.4 Volts @ 50 milliamperes  
 Output Current: 50 milliamperes  
 Output Leakage With No Input: 100 microamperes maximum @ 30 VDC  
 Output Transistor: 30 Volts breakdown

	<b>Units</b>	<b>IDC5P</b>	<b>IAC5P</b>
Input Voltage Range:	VAC	12 - 32	90 - 140
Input Current @ Maximum Line:	mA	25	11
Turn-on Time:	msec	5	20
Turn-off Time:	msec	5	20
Input Allowed For No Output:	mA, V	1, 3	3, 45
Logic Supply Voltage-Nominal:	VDC	5	5
Logic Supply Voltage Range:	VDC	4.5 - 6	4.5 - 6
Logic Supply Current:	mA	12	12
@ Nominal Logic Voltage*			
Input Resistance:	Ohms	1.5k	14k
(R1 in Schematic Diagram)			
Control Resistance:	Ohms	220	220
(Rc in Schematic Diagram)			

**AC INPUT MODULES  
FLAT PAK, PLUG-IN**

**12 - 32 VAC  
90 - 140 VAC**

**DIMENSIONS**

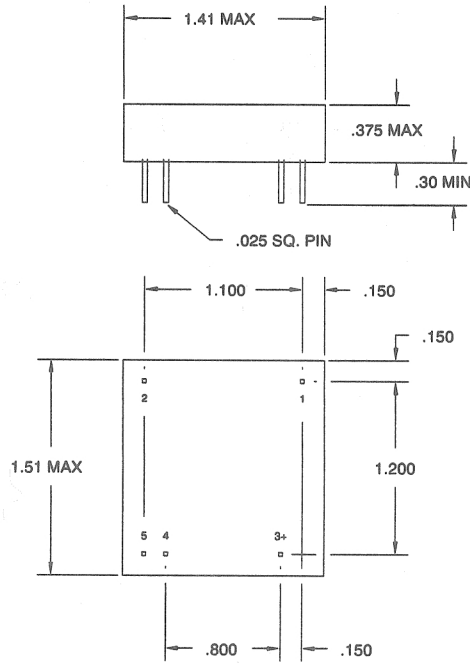

**SCHEMATIC**

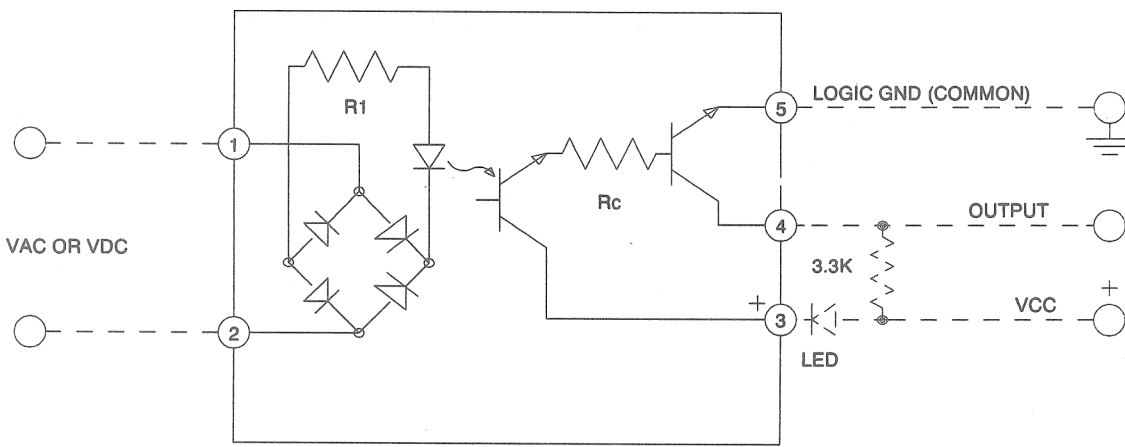

**EQUIVALENT  
CIRCUIT ONLY  
NEGATIVE TRUE LOGIC**

## AC OUTPUT MODULES FLAT PAK, PLUG-IN

12 - 140 VAC

### DESCRIPTION

The Flat Pak AC output modules are used for controlling or switching AC loads. Each module provides up to 4000 V<sub>rms</sub> of optical isolation between the field devices and the control logic. With the exception of the OAC5A5 module, all AC output modules are equivalent to a single pole, single throw, normally open contact (FORM A, SPST-NO, Make). The OAC5A5 is equivalent to a single pole, single throw, normally closed contact (FORM B, SPST-NC, Break). All AC output modules feature zero voltage turn-on and zero current turn-off.

The Flat Pak module are typical used on user-designed printed circuit boards where the standard single channel or Quad Pak module do not provide an exact fit. The Flat Pak modules are also ideal for circuit boards designed for computer chassis (i.e., Intel's MultiBus, STD bus, etc.) because of its low profile.

Typical uses and applications for AC output modules include switching the following loads:

- Relays
- Solenoids And Contactors
- Motor Starters
- Heaters
- Lamps Or Indicators

### FEATURES

- Industry standard plug-in module
- 4000 VAC optical isolation
- Current rating: 3 amperes @ 45° C
- Withstands one cycle surge of 80 amperes
- UL recognized #E58169
- CSA certified #35852
- Operating temperature: -30 to 70° C
- Zero voltage turn-on
- Zero current turn-off

### ORDERING GUIDE

Line Voltage VAC	Logic Voltage	Part Number
12 - 140	5	OAC5P

# AC OUTPUT MODULES FLAT PAK, PLUG-IN

12 - 140 VAC

## SPECIFICATIONS

### GENERAL - Applies To All Models

Current Rating:	
@ 45° C Ambient	3 amperes
@ 70° C Ambient	2 amperes
One Cycle Surge:	80 amperes peak
Peak Repetitive Voltage:	500 Volts
Operating Ambient Temperature:	-30 to 70° C
Isolation Input-To-Output:	4000 V <sub>rms</sub>
Minimum Load Current:	20 milliamperes
Operating Frequency:	25 - 65 Hz
Turn-on Time:	1/2 cycle maximum - Zero Voltage
Turn-off Time:	1/2 cycle maximum - Zero Current
DV/DT - Off-state:	200 Volts/microsecond
DV/DT - Commutating:	Snubbed for rated 0.5 power factor load
Output Voltage Drop Maximum Peak:	1.6 Volts
Off-state Leakage:	5 milliamperes, rms

### OAC5P

Line Voltage - Nominal:	120 VAC
Operating Voltage Range:	12 - 140 VAC
Logic Voltage - Nominal:	5 VAC
Logic Voltage Range (V <sub>CC</sub> ):	2.5 - 8 VDC
Logic Pickup Voltage:	2.55 VDC
Logic Dropout Voltage:	1 VDC
Logic Input Current:	12 mA
@ Normal Logic Voltage (I <sub>out</sub> in Schematic Diagram)	
Control Resistance: (R <sub>C</sub> in Schematic Diagram)	220 Ohms

# AC OUTPUT MODULES FLAT PAK, PLUG-IN

12 - 140 VAC

## DIMENSIONS

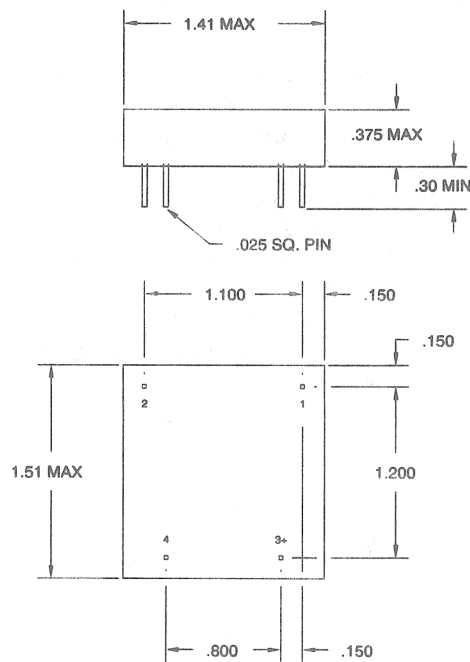

## SCHEMATIC

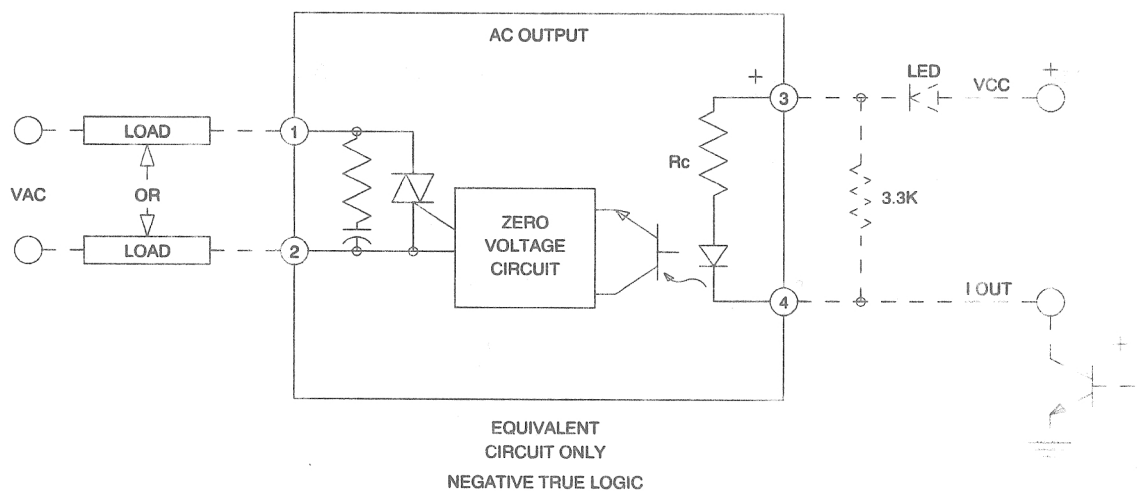

# DC INPUT MODULES FLAT PAK, PLUG-IN

10 - 32 VDC  
90 - 140 VDC

## DESCRIPTION

The Flat Pak DC input modules are used for sensing ON/OFF DC voltage levels. All DC input modules with the exception of the IDC5B and the IDC5D are designed with filtering on the input and a hysteresis amplifier for high noise rejection and transient free "clean" switching. The IDC5B module is a fast switching input module for signals produced by photoelectric switches, encoders, DC proximity switches or TTL level devices. The IDC5D is a low cost, DC only, input module for use in data acquisition applications. Each module provides up to 4000 V<sub>rms</sub> of optical isolation between the field inputs and the logic side of the circuit.

The Flat Pak module are typical used on user-designed printed circuit boards where the standard single channel or Quad Pak module do not provide an exact fit. The Flat Pak modules are also ideal for circuit boards designed for computer chassis (i.e., Intel's MultiBus, STD bus, etc.) because of its low profile.

Typical uses and applications include sensing the presence or absence of voltage or sensing contact closures from sources such as:

- Proximity Switches
- Limit Switches
- Selector Switches
- Push Button And Toggle Switches
- Photoelectric Switches
- TTL Compatible Devices

## FEATURES

- Industry standard plug-in module
- 4000 VAC optical isolation
- UL recognized #E58169
- CSA certified #35852
- Operating temperature: -30 to 70° C

## ORDERING GUIDE

Input Voltage VDC	Logic Voltage	Part Number
10 - 32	5	IDC5P
90 - 140	5	IAC5P



**DC INPUT MODULES  
FLAT PAK, PLUG-IN**

**10 - 32 VDC  
90 - 140 VDC**

**SPECIFICATIONS**

**GENERAL - Applies To All Models**

Operating Ambient Temperature: -30 to 70° C  
Isolation Input-To-Output: 4000 V<sub>rms</sub>  
Output Voltage Drop: 0.4 Volts @ 50 milliamperes  
Output Current: 50 milliamperes  
Output Leakage With No Input: 100 microamperes maximum @ 30 VDC  
Transistor: 30 Volts breakdown

	<b>Units</b>	<b>IDC5P</b>	<b>IAC5P</b>
Input Voltage Range:	VDC	10 - 32	90 - 140
Input Current @ Maximum Line:	mA	25	11
Turn-on Time:	msec	5	20
Turn-off Time:	msec	5	20
Input Allowed For No Output:	mA, V	1, 3	3, 45
Logic Supply Voltage - Nominal:	VDC	5	5
Logic Supply Voltage Range:	VDC	4.5 - 6	4.5 - 6
Logic Supply Current:	mA	12	12
@ Nominal Logic Voltage*			
Input Resistance: (R1 in Schematic Diagram)	Ohms	1k	14k
Control Resistance: (Rc in Schematic Diagram)	Ohms	220	220

**DC INPUT MODULES  
FLAT PAK, PLUG-IN**

**10 - 32 VDC  
90 - 140 VDC**

**DIMENSIONS**

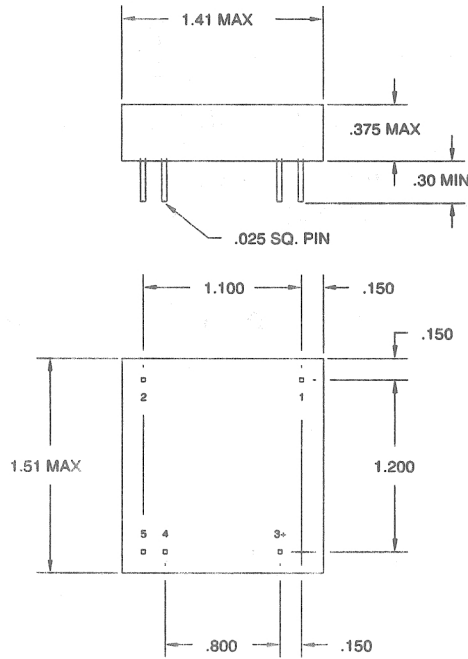

**SCHEMATIC**

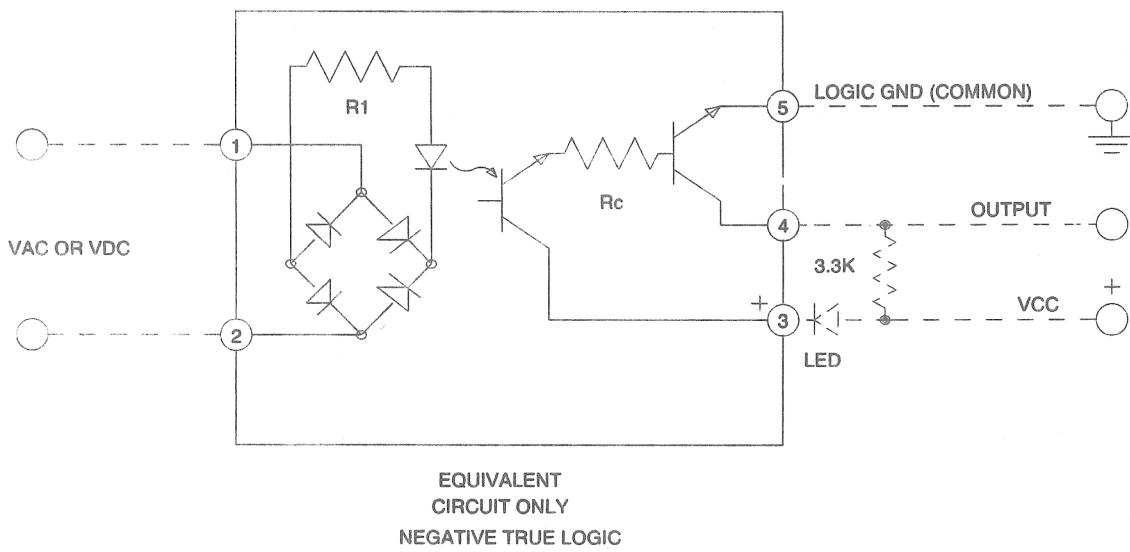

## DC OUTPUT MODULES FLAT PAK, PLUG-IN

---

5 - 60 VDC

### DESCRIPTION

The Flat Pak DC output modules are used for controlling or switching DC loads. Each module provides up to 4000 V<sub>rms</sub> of optical isolation between the field devices and the control logic.

The Flat Pak module are typical used on user-designed printed circuit boards where the standard single channel or Quad Pak module do not provide an exact fit. The Flat Pak modules are also ideal for circuit boards designed for computer chassis (i.e., Intel's MultiBus, STD bus, etc.) because of its low profile.

Typical uses and applications for DC output modules include switching the following loads:

- DC Relays
- DC Solenoids
- DC Motor Starters
- DC Lamps Or Indicators

### FEATURES

- Industry standard plug-in module
- 4000 VAC optical isolation
- Withstands one second surge at 5 amperes
- UL recognized #E58169
- CSA certified #35852
- Operating temperature: -30 to 70° C

### ORDERING GUIDE

Line Voltage VDC	Logic Voltage	Part Number
5 - 60	5	ODC5P

**SPECIFICATIONS**

**GENERAL - Applies To All Models**

One Second Surge:	5 amperes
Operating Ambient Temperature:	-30 to 70° C
Isolation Input-To-Output:	4000 V <sub>rms</sub>
Turn-on Time:	100 microseconds
Turn-off Time:	750 microseconds
Output Voltage Drop Maximum:	1.6 Volts

**ODC5P**

Line Voltage - Maximum:	60 VDC
Operating Voltage Range:	5 - 60 VDC
Current Rating:	
@ 45° C Ambient	3 Amps
@ 70° C Ambient	2 Amps
Off-state Leakage:	1 mA
@ Maximum Voltage	
Logic Voltage - Nominal:	5 VDC
Logic Voltage Range (V <sub>CC</sub> ):	2.5 - 8 VDC
Logic Pickup Voltage:	2.5 VDC
Logic Dropout Voltage:	1 VDC
Logic Input Current:	12 mA
@ Nominal Logic Voltage*	
Control Resistance:	220 Ohms
(R <sub>c</sub> in Schematic Diagram)	

# DC OUTPUT MODULE FLAT PAK, PLUG-IN

5 - 60 VDC

## DIMENSIONS

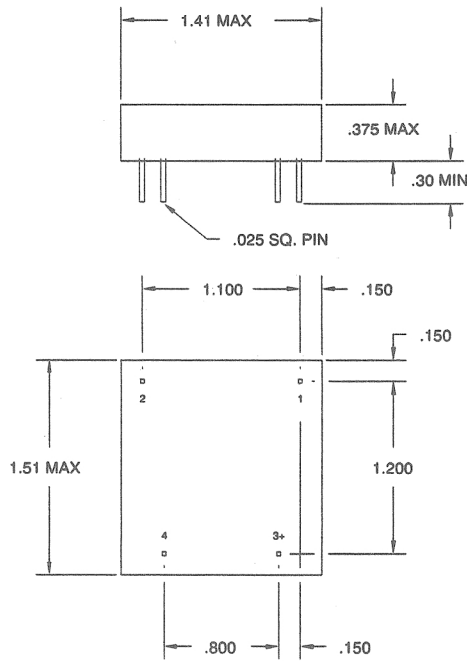

## SCHEMATIC

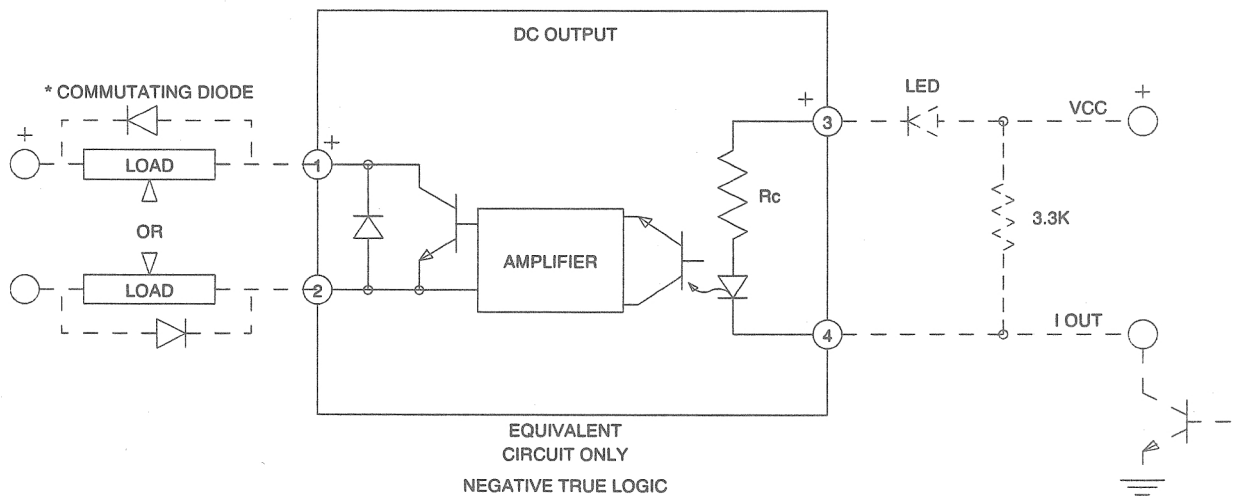

\* Must be used on inductive loads.

Note: Also compatible with Totem Pole or 3-State Output.

## X-ON Electronics

Largest Supplier of Electrical and Electronic Components

*Click to view similar products for [opto 22 manufacturer](#):*

Other Similar products are found below :

[G4AC5](#) [G4PB8H](#) [DC200MP](#) [E2](#) [PB16C](#) [240D10-17](#) [AD6T](#) [DA3](#) [SNAP-PS5-24DC](#) [SNAP-ODC5SNK](#) [SNAP-AOVA-8](#) [PB4H](#) [SNAP-AIV](#)  
[SNAP-AITM-4I](#) [GRV-EPIC-CHS4](#) [GRV-EPIC-PSDC](#) [GRV-EPIC-PSPT](#) [GRV-IAC-24](#) [GRV-IACDCTTL-24](#) [GRV-IACHV-24](#) [GRV-](#)  
[IACHVS-24](#) [GRV-IACI-12](#) [GRV-IACIHV-12](#) [GRV-IACIHVS-12](#) [GRV-IACIS-12](#) [GRV-IACS-24](#) [GRV-IDC-24](#) [GRV-IDCIS-12](#) [GRV-](#)  
[IDCS-24](#) [GRV-IMA-24](#) [GRV-ITMI-8](#) [GRV-OAC-12](#) [GRV-OACI-12](#) [GRV-OACIS-12](#) [GRV-OACS-12](#) [GRV-ODCIS-12](#) [GRV-OMRIS-8](#)  
[AD10T2](#) [AD8T](#) [DA8](#) [IAC15](#) [SNAP-PAC-EB1-FM](#) [FUSEG4B](#) [120D45](#) [DA4](#) [SNAP-B16MC](#) [AD12](#) [G4AD3](#) [B5](#) [DA4T](#)