

Powerex, Inc., 200 Hillis Street, Youngwood, Pennsylvania 15697-1800 (412) 925-7272  
 Powerex, Europe, S.A. 428 Avenue G. Durand, BP107, 72003 Le Mans, France (43) 41.14.14

**Phase Control SCR**  
**350 Amperes Average**  
**4500 Volts**

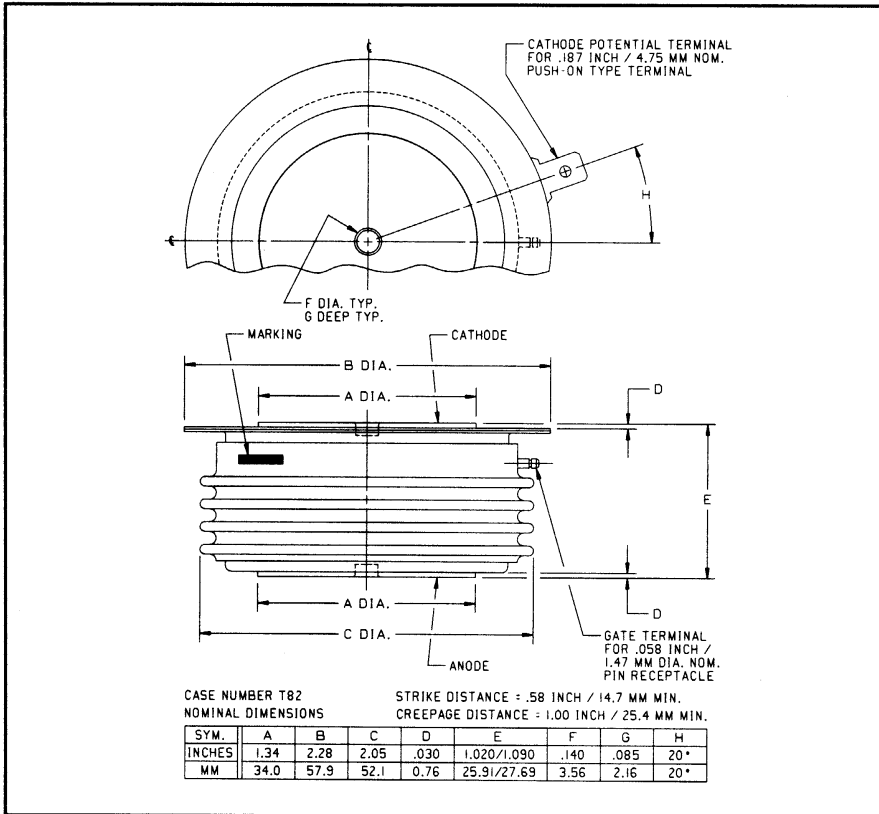

T8K7 350A (Outline Drawing)

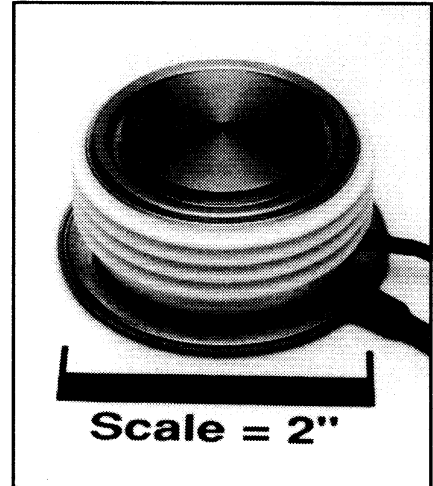

T8K7 350A Phase Control SCR  
 350 Amperes Average, 4500 Volts

### Ordering Information:

Select the complete 12 digit part number you desire from the table below.

Type	Voltage	Current	Turn-off	Gate Current	Lead Code
	$V_{DRM}/V_{RRM}$ (Volts)	$I_{T(av)}$ (A)	$I_q$ ( $\mu$ sec)	$I_{GT}$ (mA)	
T8K7	36 40 45	35	0	3	DH
	3600V 4000V 4500V	350A	250 $\mu$ sec (Typical)	200mA	12"

### Description:

Powerex Silicon Controlled Rectifiers (SCR) are designed for phase control applications. These are all-diffused, Press-Pak, hermetic Pow-R-Disc devices employing the field proven amplifying gate.

### Features:

- Low On-State Voltage
- High di/dt Capability
- High dv/dt Capability
- Hermetic Packaging
- Excellent Surge and  $I^2t$  Ratings

### Applications:

- Power Supplies
- Motor Control



Powerex, Inc., 200 Hillis Street, Youngwood, Pennsylvania 15697-1800 (412) 925-7272  
Powerex, Europe, S.A. 428 Avenue G. Durand, BP107, 72003 Le Mans, France (43) 41.14.14

**T8K7 350A**  
**Phase Control SCR**  
350 Amperes Average, 4500 Volts

### Absolute Maximum Ratings

Characteristics	Symbol	T8K7 350A	Units
Non-repetitive Transient Peak Reverse Voltage	$V_{RSM}$	$V_{RRM} + 100V$	Volts
RMS On-state Current, $T_C = 76^\circ C$	$I_{T(rms)}$	550	Amperes
Average Current 180° Sine Wave, $T_C = 76^\circ C$	$I_{T(av)}$	350	Amperes
RMS On-state Current, $T_C = 55^\circ C$	$I_{T(rms)}$	710	Amperes
Average Current 180° Sine Wave, $T_C = 55^\circ C$	$I_{T(av)}$	450	Amperes
Peak One Cycle Surge On-state Current (Non-repetitive) 60Hz	$I_{tsm}$	5500	Amperes
Peak One Cycle Surge On-state Current (Non-repetitive) 50Hz	$I_{tsm}$	5060	Amperes
Critical Rate-of-rise of On-state Current (Non-repetitive)	$di/dt$	500	A/ $\mu$ sec
Critical Rate-of-rise of On-state Current (Repetitive)	$di/dt$	150	A/ $\mu$ sec
$I^2t$ (for Fusing) for One Cycle, 60Hz	$I^2t$	100,000	A <sup>2</sup> sec
Peak Gate Power Dissipation	$P_{GM}$	50	Watts
Average Gate Power Dissipation	$P_{G(av)}$	5	Watts
Operating Temperature	$T_j$	-40 to +125°C	°C
Storage Temperature	$T_{stg}$	-40 to +150°C	°C
Approximate Weight		8	oz.
		227	g
Mounting Force		3000 to 3500	lb.
		1360 to 1590	kg.

**T8K7 350A**  
**Phase Control SCR**  
 350 Amperes Average, 4500 Volts

## Electrical Characteristics, $T_j = 25^\circ\text{C}$ Unless Otherwise Specified

Characteristics	Symbol	Test Conditions	Min.	Typ.	Max.	Units
Repetitive Peak Reverse Leakage Current	$I_{RRM}$	$T_j = 125^\circ\text{C}, V_R = V_{RRM}$			75	mA
Repetitive Peak Forward Leakage Current	$I_{DRM}$	$T_j = 125^\circ\text{C}, V_D = V_{DRM}$			75	mA
Peak On-state Voltage	$V_{TM}$	$I_{TM} = 1000\text{A Peak}$ $t_p = 8\text{msec}$			3.5	Volts
Threshold Voltage, Low-level	$V_{(TO)1}$	$T_j = 125^\circ\text{C}, I = 15\%, I_{T(av)}$ to $\pi I_{T(av)}$			1.5618	Volts
Slope Resistance, Low-level	$r_{T1}$				2.1412	m $\Omega$
Threshold Voltage, High-level	$V_{(TO)2}$	$T_j = 125^\circ\text{C}, I = \pi I_{T(av)}$ to $I_{TSM}$			2.7113	Volts
Slope Resistance, High-level	$r_{T2}$				0.96929	m $\Omega$
$V_{TM}$ Coefficients, Low-level		$T_j = 125^\circ\text{C}, I = 15\% I_{T(av)}$ to $\pi I_{T(av)}$				
					$A_1 = 1.1505$	
					$B_1 = -0.14678$	
					$C_1 = -9.586\text{E-}04$	
					$D_1 = 0.13681$	
$V_{TM}$ Coefficients, High-level		$T_j = 125^\circ\text{C}, I = \pi I_{T(av)}$ to $I_{TSM}$				
					$A_2 = -13.457$	
					$B_2 = 3.0936$	
					$C_2 = 1.627\text{E-}03$	
					$D_2 = -0.19076$	
Typical Delay Time	$t_d$	$V_D = 0.5V_{DRM}$		2.0		$\mu\text{sec}$
Typical Turn-off Time	$t_q$	$V_R = 100\text{V},$ $di_R/dt = 5\text{A}/\mu\text{sec}$ Reapplied $dv/dt = 20\text{V}/\mu\text{sec}$ Linear to $50\% V_{DRM}$		250		$\mu\text{sec}$
Minimum Critical $dv/dt$ - Linear to $V_{DRM}$	$dv/dt$	$T_j = 125^\circ\text{C}, V_D = 0.67V_{DRM}$	500	1000		$\text{V}/\mu\text{sec}$
Gate Trigger Current	$I_{GT}$	$T_j = 25^\circ\text{C}, V_D = 12\text{V}$			200	mA
Gate Trigger Voltage	$V_{GT}$	$T_j = 25^\circ\text{C}, V_D = 12\text{V}$			3.0	Volts
Peak Reverse Gate Voltage	$V_{GRM}$				4.0	Volts

## Thermal Characteristics

Maximum Thermal Resistance, Double Sided Cooling

Junction-to-Case	$R_{\theta(j-c)}$		0.040	$^\circ\text{C}/\text{W}$
Case-to-Sink	$R_{\theta(c-s)}$		0.020	$^\circ\text{C}/\text{W}$

Powerex, Inc., 200 Hillis Street, Youngwood, Pennsylvania 15697-1800 (412) 925-7272  
 Powerex, Europe, S.A. 428 Avenue G. Durand, BP107, 72003 Le Mans, France (43) 41.14.14

**T8K7 350A**  
**Phase Control SCR**  
 350 Amperes Average, 4500 Volts

**Maximum On-State Forward Voltage Drop**  
 (  $T_J = 125^\circ\text{C}$  )

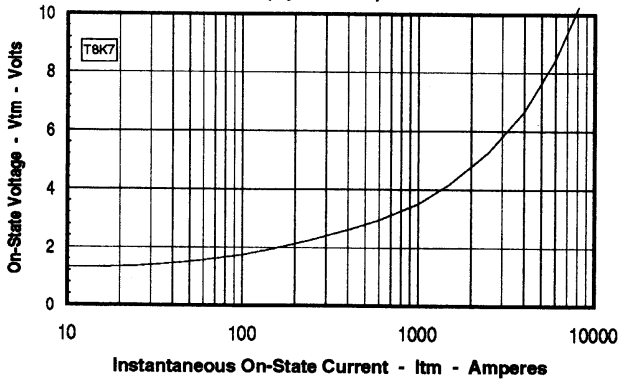

**Maximum Transient Thermal Impedance**  
 (Junction to Case)

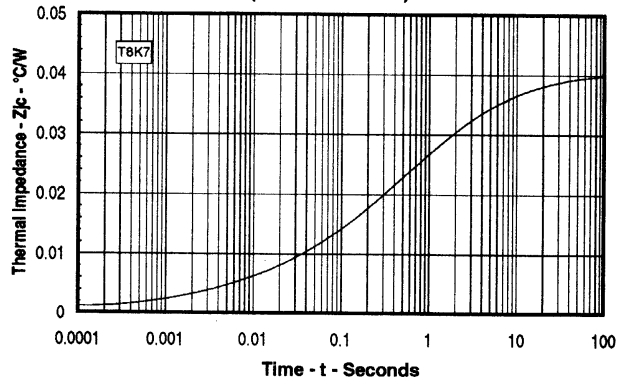

**Maximum On-State Power Dissipation**  
 (Sinusoidal Waveform)

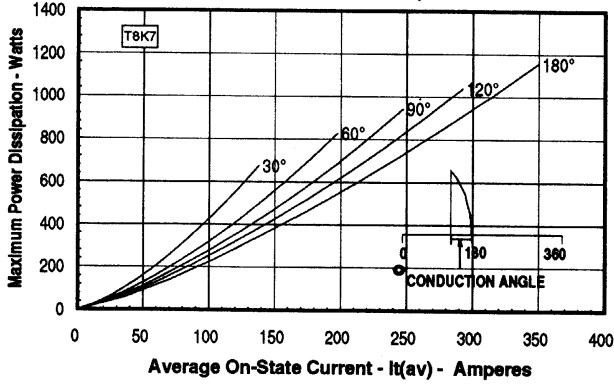

**Maximum Allowable Case Temperature**  
 (Rectangular Waveform)

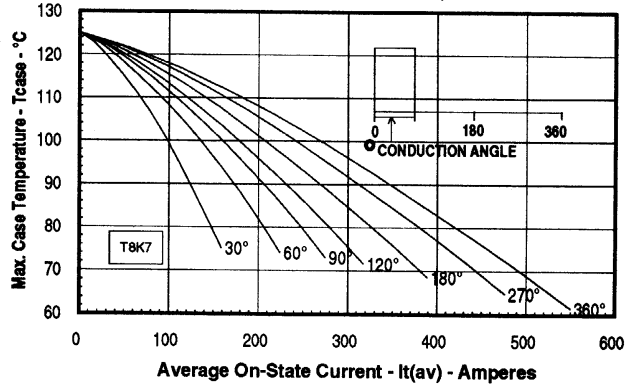

**Maximum On-State Power Dissipation**  
 (Rectangular Waveform)

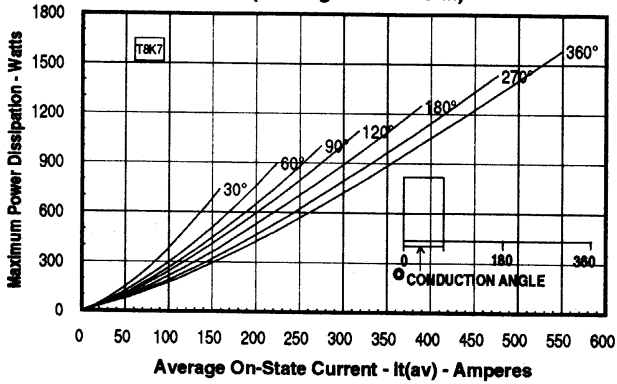

**Maximum Allowable Case Temperature**  
 (Rectangular Waveform)

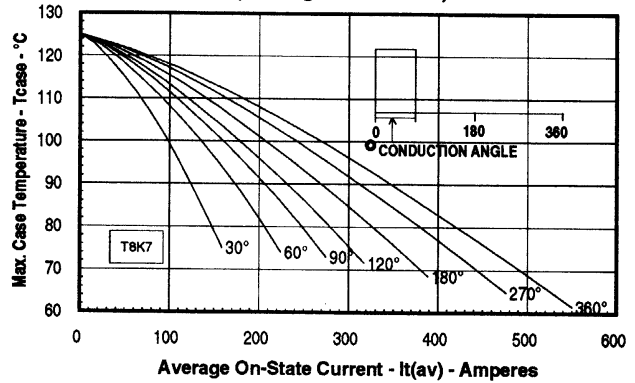

## **X-ON Electronics**

Largest Supplier of Electrical and Electronic Components

*Click to view similar products for [powerex manufacturer](#):*

Other Similar products are found below :

[R7013003XXUA](#) [R9G01212XX](#) [VLA541-01R](#) [QRD0630T30](#) [CM400DY-24NF](#) [CM100TX-24S1](#) [CM600HA-24A](#) [NLD422PB](#)  
[PSM03S93E5-A](#) [BP2B-V](#) [ND431625](#) [R5031213LSWS](#) [BG2B](#) [BG2C-5015](#) [ND431825](#) [T9G0121203DH](#) [CD611616C](#) [BG1A-PX](#)  
[TCS4402802DH](#) [CD421690C](#) [PM600DVA060](#) [CD411899C](#) [CD631615B](#) [C601PB](#) [R5021213LSWS](#) [BG2A-NFH](#) [C180PB](#) [CD431690B](#)  
[NLR425CM](#) [HARDWARE KIT 50](#) [CD410899C](#) [CM400HA-24A](#) [CD411699C](#) [LEAD KIT #NK](#) [HARDWARE KIT 49](#) [VLA500-01](#)  
[HARDWARE KIT 87](#) [VLA502-01](#) [VLA106-24154](#) [VLA106-15242](#)