

# 856977

## 787.5 MHz SAW Filter

### Applications

- General purpose wireless
- Wireless infrastructure
- 3G, 4G, Multistandard
- Repeaters

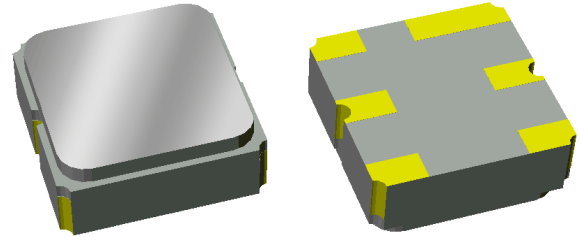

### Product Features

- Usable bandwidth 21 MHz
- High attenuation
- Low Loss
- Single-ended operation
- Matching required for operation at 50Ω
- Small Size: 3.00 x 3.00 x 1.22 mm
- Ceramic Surface Mount Package (SMP)
- Hermetically sealed
- **RoHS** compliant, **Pb**-free

### General Description

Uplink filter combining bands 13 and 14 for general purpose wireless applications. This filter was specifically designed in a 3x3mm hermetic package for base station applications and is part of our wide portfolio of RF filters in the same package.

Low insertion loss, coupled with high attenuation and good power handling, makes this filter a natural choice for our customers uplink RF filtering needs.

### Functional Block Diagram

Top view

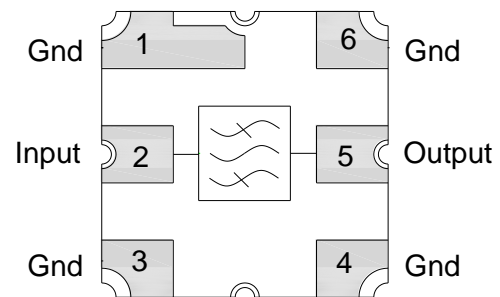

### Pin Configuration

Pin # SE	Description
2	Input
5	Output
1,3,4,6	Case Ground

### Ordering Information

Part No.	Description
856977	packaged part
856977-EVB	evaluation board

Standard T/R size = 5000 units/reel.

## Specifications

### Electrical Specifications <sup>(1)</sup>

Specified Temperature Range: <sup>(2)</sup> -30 to +85 °C

Parameter <sup>(3)</sup>	Conditions	Min	Typical <sup>(4)</sup>	Max	Units
Center Frequency		-	787.5	-	MHz
Maximum Insertion Loss	777 – 798 MHz	-	2.05	2.75	dB
Amplitude Variation <sup>(5)</sup>	777 – 798 MHz	-	0.5	1.4	dB
Amplitude Ripple (any 5 MHz in passband) <sup>(6)</sup>	777 – 798 MHz	-	0.5	1.0	dB p-p
Amplitude Ripple <sup>(6)</sup>	777 – 798 MHz	-	0.5	1.2	dB p-p
Phase Ripple	777 – 798 MHz	-	42	55	deg p-p
Group Delay Ripple	777 – 798 MHz	-	39	60	ns p-p
Absolute Group Delay	777 – 798 MHz	-	48	55	ns
Attenuation <sup>(7)</sup>	70 – 120 MHz	50	74	-	dB
	430 – 470 MHz	40	66	-	dB
	591 – 614 MHz	30	60	-	dB
	746 – 765 MHz	15	23	-	dB
	765 – 768 MHz	5	23	-	dB
	818 – 824 MHz	10	21	-	dB
	843 – 857 MHz	40	53	-	dB
	1005 – 1026 MHz	30	55	-	dB
	1688 – 1711 MHz	42	52	-	dB
	2010 – 2052 MHz	30	58	-	dB
	2922 – 2964 MHz	20	42	-	dB
Input/Output VSWR	777 – 798 MHz	-	1.4	2.0	-
Source/Load Impedance <sup>(8)</sup>	Single-ended	-	50	-	Ω

Notes:

- All specifications are based on the TriQuint schematic for the main reference design shown on page 3
- In production, devices will be tested at room temperature to a guardbanded specification to ensure electrical compliance over temperature
- Electrical margin has been built into the design to account for the variations due to temperature drift and manufacturing tolerances
- Typical values are based on average measurements at room temperature
- Describes the total variation over the defined frequency range
- This is defined as the worst difference between a peak and adjacent valley within defined frequency points
- Relative to passband loss at center frequency
- This is the optimum impedance in order to achieve the performance shown

### Absolute Maximum Ratings

Parameter	Rating
Operating Temperature <sup>(9)</sup>	-40 to +85 °C
Storage Temperature	-40 to +85 °C
Input Power (10Khrs @ 55 °C under CW signal) <sup>(10)</sup>	+20 dBm

9. Device may operate over this range with degraded Electrical Specifications

10. Device can also meet +22dBm power for an applied CW modulated CW signal at 55 deg C for a minimum of 125 hours in the 777.0-798.0 MHz frequency band"

Operation of this device outside the parameter ranges given above may cause permanent damage.

**Reference Design**

**Schematic**

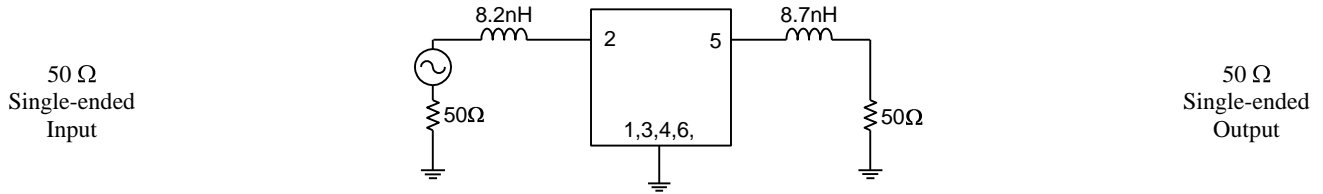

**PC Board**

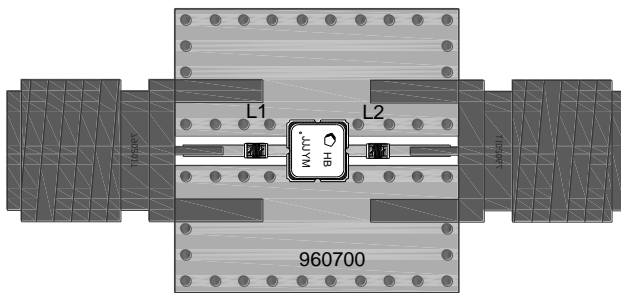

**Mounting Configuration**

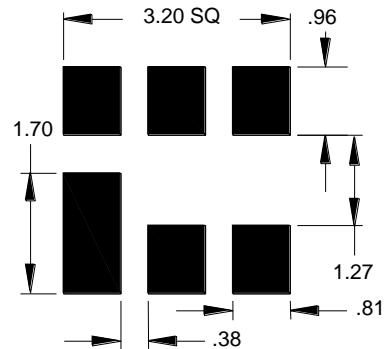

Notes:

- Top, middle & bottom layers: 1 oz copper
- Substrates: FR4 dielectric, .031" thick
- Finish plating: Nickel: 3-8µm thick, Gold: .03-.2µm thick
- Hole plating: Copper min .0008µm thick

Notes:

- 1. All dimensions are in millimeters.
- 2. This footprint represents a recommendation only.

**Bill of Material**

Reference Desg.	Value	Description	Manufacturer	Part Number
L1	8.2nH	Coil Wire-wound, 0402, 5%	Murata	LQW15AN8N2J00
L2	8.7nH	Coil Wire-wound, 0402, 5%	Murata	LQW15AN8N7J00
SMA	N/A	SMA connector	Radiall USA Inc.	9602-1111-018
PCB	N/A	3-layer	multiple	960700

**Typical Performance (at room temperature)**

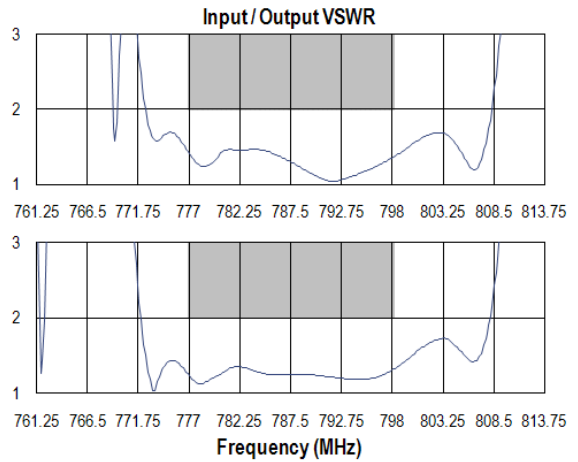
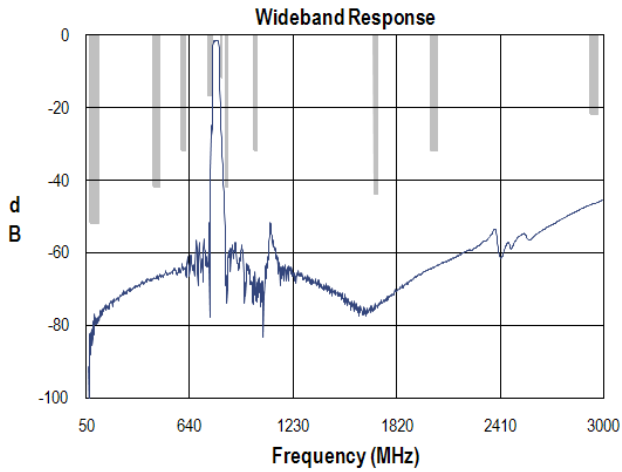
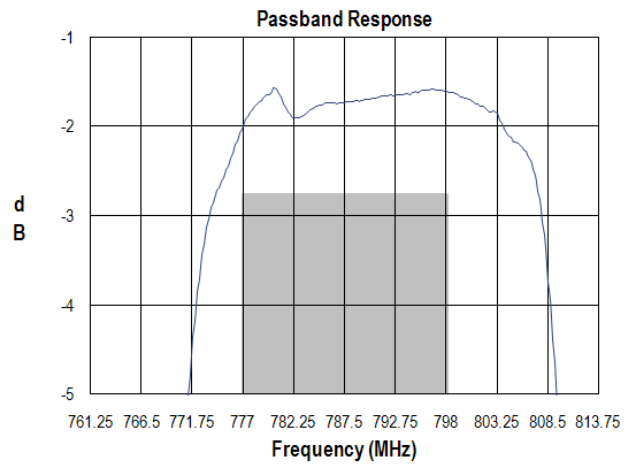
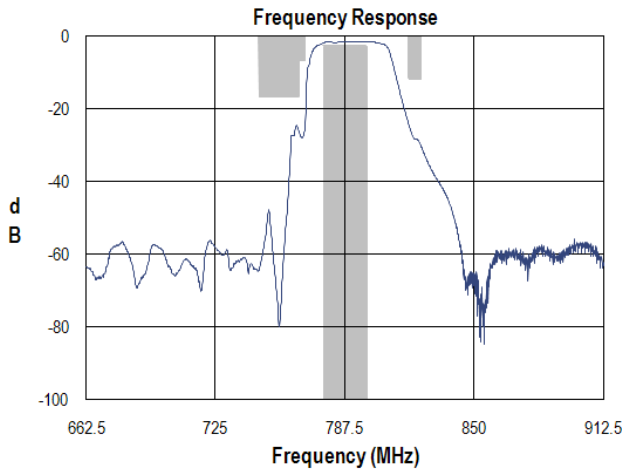

**Input Smith Chart**

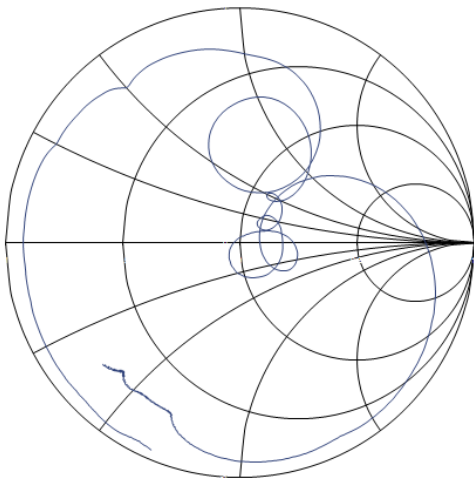

**Output Smith Chart**

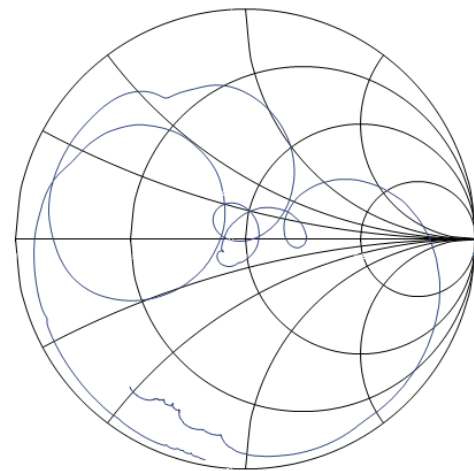

# 856977

## 787.5 MHz SAW Filter

### Mechanical Information

#### Package Information, Dimensions and Marking

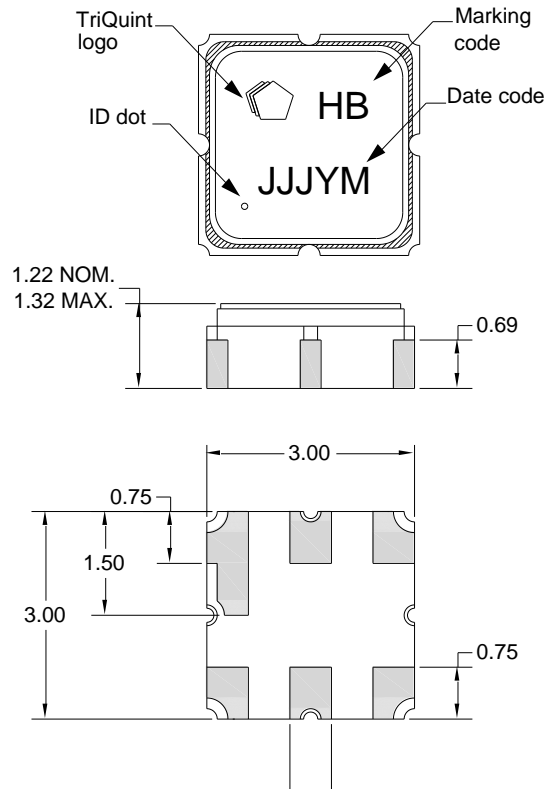

Package Style: SMP-12A  
Dimensions: 3.00 x 3.00 x 1.22 mm

Body:  $Al_2O_3$  ceramic  
Lid: Kovar, Ni plated  
Terminations: Au plating 0.5 - 1.0  $\mu$ m, over a 2-6  $\mu$ m Ni plating

All dimensions shown are nominal in millimeters  
All tolerances are  $\pm 0.15$ mm except overall length and width  $\pm 0.10$ mm

The date code consists of day of the current year (Julian, 3 digits), Y = last digit of the year, and M = manufacturing site code

### Tape and Reel Information

Standard T/R size = 5000 units/reel. All dimensions are in millimeters

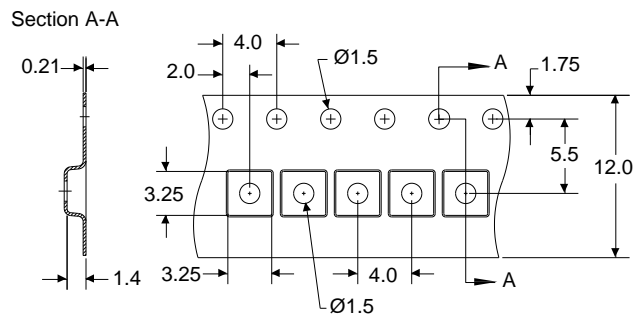
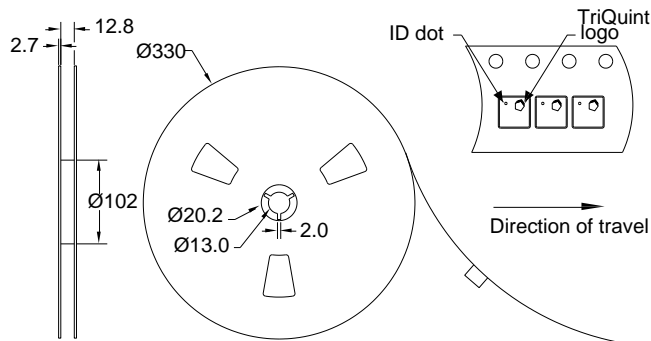

## Product Compliance Information

### ESD Information



#### Caution! ESD-Sensitive Device

ESD Rating: 0

Value: Passes  $\geq 200$  V min.  
 Test: Human Body Model (HBM)  
 Standard: JEDEC Standard JESD22-A114

ESD Rating: A

Value: Passes  $\geq 150$  V min.  
 Test: Machine Model (MM)  
 Standard: JEDEC Standard JESD22-A115

### MSL Rating

Devices are Hermetic, therefore MSL is not applicable

### Solderability

Compatible with the latest version of J-STD-020, lead free solder, 260°C

Refer to [Soldering Profile](#) for recommended guidelines.

This part is compliant with EU 2002/95/EC RoHS directive (Restrictions on the Use of Certain Hazardous Substances in Electrical and Electronic Equipment).

This product also has the following attributes:

- Halogen Free (Chlorine, Bromine)
- Antimony Free
- TBBP-A (C<sub>15</sub>H<sub>12</sub>Br<sub>4</sub>O<sub>2</sub>) Free
- PFOS Free
- SVHC Free

## Contact Information

For the latest specifications, additional product information, worldwide sales and distribution locations, and information about TriQuint:

Web: [www.triquint.com](http://www.triquint.com)      Tel: +1.407.886.8860  
 Email: [info-sales@tqs.com](mailto:info-sales@tqs.com)      Fax: +1.407.886.7061

For technical questions and application information:

Email: [flapplication.engineering@tqs.com](mailto:flapplication.engineering@tqs.com)

## Important Notice

The information contained herein is believed to be reliable. TriQuint makes no warranties regarding the information contained herein. TriQuint assumes no responsibility or liability whatsoever for any of the information contained herein. TriQuint assumes no responsibility or liability whatsoever for the use of the information contained herein. The information contained herein is provided "AS IS, WHERE IS" and with all faults, and the entire risk associated with such information is entirely with the user. All information contained herein is subject to change without notice. Customers should obtain and verify the latest relevant information before placing orders for TriQuint products. The information contained herein or any use of such information does not grant, explicitly or implicitly, to any party any patent rights, licenses, or any other intellectual property rights, whether with regard to such information itself or anything described by such information.

TriQuint products are not warranted or authorized for use as critical components in medical, life-saving, or life-sustaining applications, or other applications where a failure would reasonably be expected to cause severe personal injury or death.

## X-ON Electronics

Largest Supplier of Electrical and Electronic Components

*Click to view similar products for [triqunt semiconductor manufacturer](#):*

Other Similar products are found below :

[WJA1510-PCB](#) [854916](#) [TQP7M9106-PCB900](#) [TQP3M9008-PCB-RF](#) [TQP3M9009-PCB-RF](#) [TQP4M9072-PCB\\_IF](#) [TQP7M9103-PCB2140](#)  
[WJA1500-PCB](#) [TQL9048-PCB-RF](#) [TQL9047-PCB-RF](#) [TQP3M9007-PCB](#) [TQP3M9038-PCB-RF](#) [TQM879028-PCB2140](#) [TQP369182-PCB](#)  
[TQP3M9005-PCB](#) [TQP3M9035-PCB](#) [TQP369181-PCB](#) [TQP3M9028-PCB-RF](#) [TQP3M9019-PCB-RF](#) [TGA2575](#) [TQP369185-PCB](#)  
[TGA2583-SM](#) [TGA2576-2-FL](#) [TQP3M9037-PCB](#) [TGA2585-SM](#) [TGA2594](#) [855735](#) [TGP2102](#) [TGS2353-2-SM](#) [TGA4030-SM](#) [TGF2023-2-](#)  
[01](#) [TGL4203](#) [TGA4521](#) [880157](#) [854662](#) [TGA2565-SM](#) [TQP770001](#) [TGA2526](#) [TGA4522](#) [TAT7461](#) [TGF2023-2-02](#) [TQL1600](#) [TAT7460](#)  
[TGL4201-00](#) [TGL4201-10](#) [TQP7M9106](#) [TAT7430B](#) [1100031](#) [TAT7461-P](#) [856020](#)