

Section 1: Weldments

Thank you for purchasing the GEMS SureSite Magnetic Level Indicator. **Please read this document prior to installing your SureSite** and store it where it may be readily referred to for familiarization and maintenance purposes. If you require any additional information, you are welcome to call GEMS at the number shown below.

1-800-321-6070

(Outside of the Continental U.S., call 860-747-3000)

Record the Part Number of your SureSite here to use when ordering spare or replacement parts:

Part Number: _____

SureSite Operating Principle

The liquid level of a tank is made visible, **even at great distances**, through the use of a shock and vibration-proof magnetic level indicator that employs “flags” arranged within a specially constructed external housing: **the flag assembly**. The two sides of each pivoting flag are marked with contrasting colors. A permanent magnet is encapsulated inside each flag and forms a secure magnetic interlock with the adjacent flags. As the liquid level rises, a float equipped with a permanent magnet causes each of the flags to begin rotating in turn. This action exposes the contrasting (fluid level indicating) color on the other side of the flag. As the float and liquid level rise, each flag below the level of the float completes a 180 degree rotation, while remaining magnetically interlocked with the other lower flags. Together, the rotated flags display a band or column of color, the height of which corresponds with the liquid level within the tank. An exclusive feature of the SureSite is the magnetic guide that is integrated into the flag assembly. This magnetic attraction ensures that the float is always aligned for optimum performance and exactness, regardless of any shock, vibration, or rapid change to the level of fluid in the tank.

Standard and Mini-SureSites are supplied with the floats packed either separately, or securely strapped to the unit. Top-mounted SureSites are typically supplied with the floats installed and secured by a support tube. The float supplied with each unit has been designed to the specific gravity of the fluid being monitored, so that the permanent bar magnet will always seek and indicate the fluid surface. Because of the attraction of the permanent bar magnet in the float and the patented magnetic guide, the SureSite flag assembly can be rotated to a position which will allow for optimum viewing.

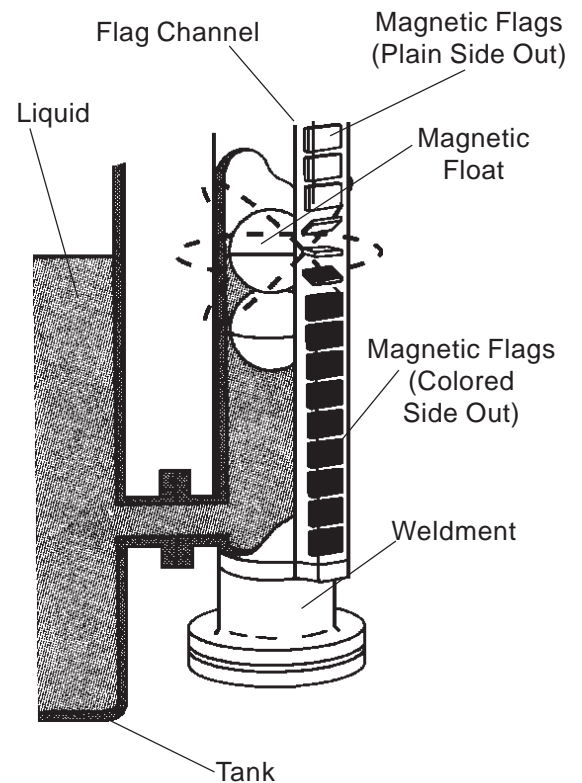

(See the Maintenance Section on page 5 for instructions on how to rotate your SureSite flag assembly.)

Important!

Read the following instructions completely - BEFORE installing the SureSite.

Installation Precautions and Preparation

Failure to observe these precautions could affect the operation of your unit.

1. When locating the tank ports for the SureSite, make sure that no strong magnetic fields or magnetic materials (such as railings, protective cages, I-beams, etc.) will be any closer than 6 inches (153 mm) from the SureSite.
2. Make necessary efforts to ensure that all tank-side modifications and equipment; i.e., the mating flanges, NPT ports or shut-off valves (if used) will align properly with the SureSite connections. Improper alignment could cause distortion and may damage welds and compromise the integrity of the SureSite and/or the tank.
3. After any necessary tank modifications are completed, the tank should be cleaned to remove contaminants. This will ensure that the installation is free of foreign particles; especially those which could be magnetic and which could impair the performance of the SureSite.
4. Do not begin the installation of the SureSite until all necessary tools and materials are obtained. (Such as mating flange gaskets, bolting hardware, etc.)
5. Gasket material typically supplied with the standard SureSite unit is either Viton or nitrile rubber, Garlock 3000 style. Higher pressure units are typically supplied with Flexitallic™ gaskets. For replacement gaskets, please consult GEMS Sensors for your specific material type.
6. All supplied flag assembly clamps are intended to be installed with a torque on the clamp screw not to exceed 5 lb.-inches.

Installation

Caution

Handle the SureSite with care to avoid damaging the threaded areas, flange surfaces, etc.

Note

If you have a top-mounted alloy or top-mounted plastic SureSite, skip to Page 4 for instructions.

For Standard SureSites (Alloy, Mini and Plastic)

1. Remove the protective packing materials from your SureSite.
2. Position the unit horizontally on a level surface.
3. Unpack the float assembly or, with the aid of a wire-cutter or similar device, remove the strapping that secures the float to the exterior of the SureSite Unit.

Warning

DO NOT: 1) Hold the SureSite in a vertical position or 2) Drop the float assembly into the unit. Avoid this or any action which could damage or dent the float. Such damage could cause the float to crush under normal working pressures.

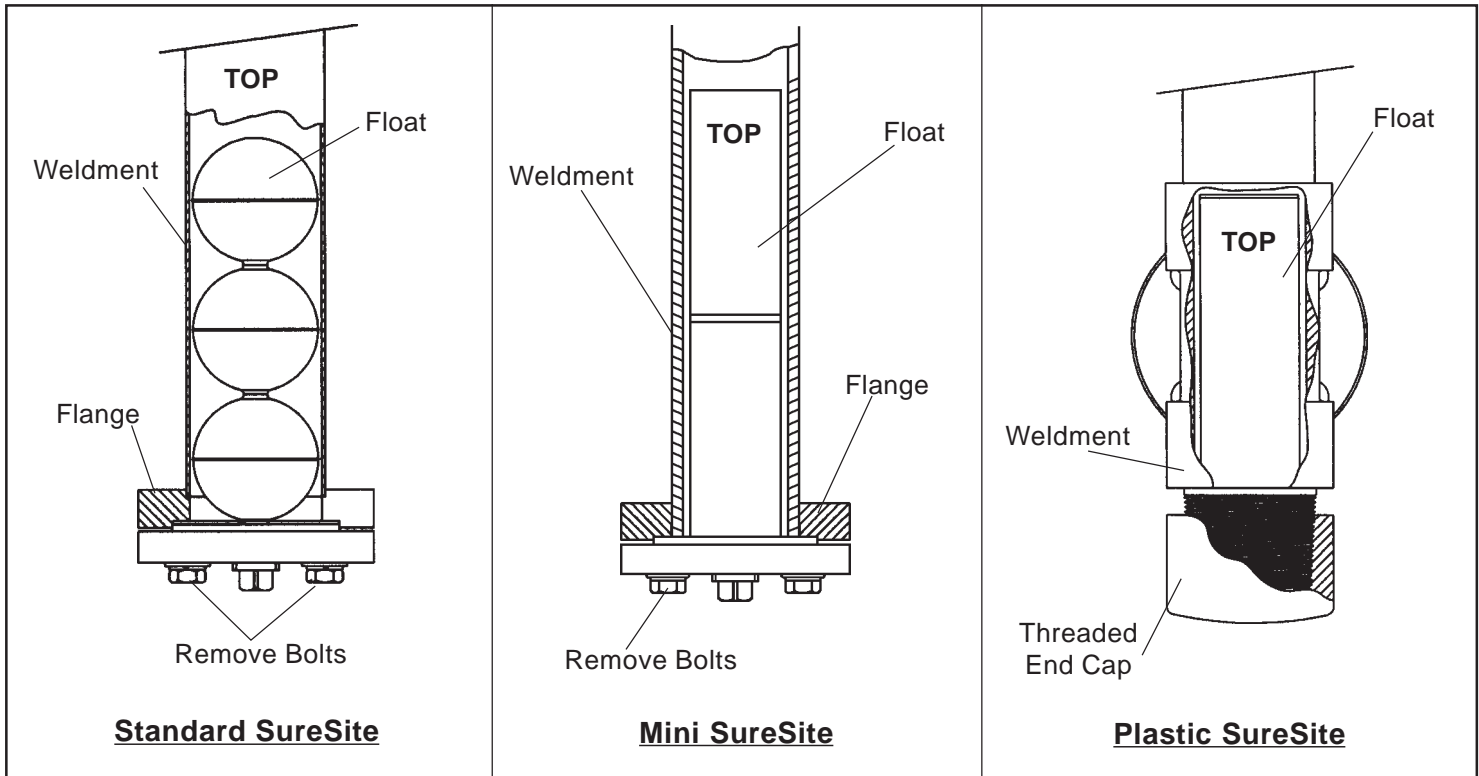

4. Remove the end cap or flange attaching bolts, as indicated in the appropriate drawing. Then remove the end cap or flange.
5. With the unit still in a horizontal position, insert the float assembly into the weldment, with the "TOP" indication on the float assembly moving in the same direction as the "UP" arrows that are located on each side of the externally mounted flag assembly.
6. With the gasket or O-ring properly positioned, reassemble the end cap or flange to the weldment. Tighten the end cap or flange bolts securely, using the proper recommended torque value as supplied in **Figure A, page 5**.
7. Slowly raise the top end of the SureSite, while the bottom end remains on the level surface, permitting the float to slowly slide to the bottom, avoiding any sudden impact damage to the float assembly.
8. Move the SureSite to the tank and position the unit with the end marked "TOP" pointing upwards. Install any necessary mounting gaskets or seals², and align the mating port flanges, NPT's or connections of the tank with those of the SureSite. **DO NOT ATTEMPT TO FORCE ALIGNMENT.** To do so may damage the welds or compromise the integrity of the SureSite. While following standard practices and procedures, tighten the flange bolts, NPT's or connections. Recommended torque values are supplied in **Figure A, page 5**.
9. **Before Filling the Tank . . .** Be sure that the installation is free of foreign particles, especially any that are magnetic. Check that all connections are secure. A hydrostatic pressure test of the complete assembly is recommended.

NOTE

GEMS recommends that you include at least one support bracket in your installation for SureSite units greater than 10 feet (120 inches, 3048 mm) in length. Depending on the specific installation, a load-bearing support at the base of the SureSite may be beneficial.

² Gaskets or seals for the port flanges are not supplied with the SureSite.

Installation for Top-Mounted Alloy SureSites

1. After removing any protective packing materials from your top-mounted SureSite and positioning it horizontally on a level surface, remove and discard the protective cap from the bottom of the SureSite and carefully withdraw the cardboard support tube.
2. Slowly raise the top end of the SureSite, while the bottom end remains on the level surface; permitting the float to slowly slide to the bottom and avoiding any sudden impact damage to the float assembly.
3. Position the necessary gasket or O-ring seal³ on the tank mounting flange and align the unit so that the bolt holes of the mating flange match. The indicating face of the flag assembly should be directed towards your desired point of observation. Do not attempt to force alignment. To do so may damage the welds or compromise the integrity of the SureSite.
4. While following standard practices and procedures, tighten the flange bolts with the recommended torque values as supplied in **Figure A, page 5.**

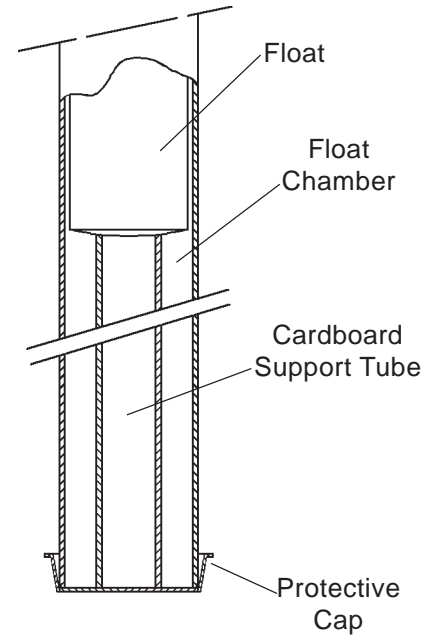

Installation for Top-Mounted Plastic SureSites

1. Remove the threaded stop pin from the bottom of the top-mounted SureSite and slowly withdraw the support tube. Reinstall the stop pin.
2. Slowly raise the top end of the SureSite, while the bottom end remains on the level surface; permitting the float to slowly slide to the bottom and avoiding any sudden impact damage to the float assembly.
3. Position the necessary gasket or O-ring seal³ on the tank mounting flange and align the unit so that the bolt holes of the mating flange match. The indicating face of the flag assembly should be directed towards your desired point of observation. Do not attempt to force alignment. To do so may damage the welds or compromise the integrity of the SureSite.
4. While following standard practices and procedures, tighten the flange bolts with the recommended torque values as supplied in **Figure A, page 5.**

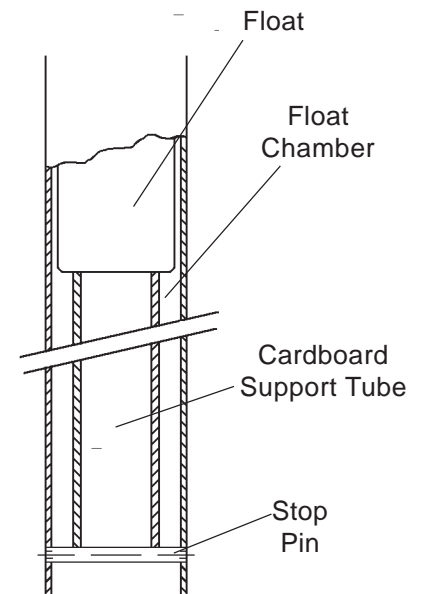

³ Gaskets or seals for the port flanges are not supplied with the SureSite.

Figure A
(Recommended Torque Values are for Lubricated Threads, Only)

Indicator Type	Fastener Description	Nominal Size	Torque Value
Standard Alloy, Top-Mount Alloy	Bolt, Nut	3/8 Inch	70 - 80 Lb.-Inches NTE (Not to Exceed) 120 Lb.-Inches
		1/2 Inch	30 Lb-Feet
		5/8 Inch	60 Lb-Feet
		3/4 Inch	100 Lb-Feet
		7/8 Inch	150 Lb-Feet
		1 Inch	250 Lb-Feet
		1-1/8 Inch	350 Lb-Feet
Standard Plastic, Top-Mount Plastic	Bolt, Nut		15-20 Lb-Feed (Valid for bolts with flat washers under both bolt-heads and nuts)
Mini	Bolt, Nut	5/16 Inch	70 - 80 Lb-Inches

Flag Installation

General Notes

Under normal circumstances, it should not be necessary to reposition the flag assembly on your SureSite. However, if you find it desirable or necessary to reposition the flag assembly, we strongly recommend that you first mark the distance from the top of the weldment to the top of the flag assembly. Before securing the flag assembly in a new radial position, ensure that the distance from the top of the flag assembly to the top of the weldment is the same as the previously noted dimension. Making a temporary or permanent mark on the weldment can ease the process.

Maintenance

The only maintenance typically required is to ensure that the internal walls of the weldment and the float are free of foreign matter. This may be accomplished by removing the float assembly from the unit and wiping both the float and the inside wall of the float chamber or weldment. Any maintenance interval is to be established by the user of the SureSite and would depend upon the characteristics of the application. Maintenance could coincide with tank cleaning or flushing.

Float Installation

Mini SureSite Float: (To set magnet position, please go to page 8.)

To accomplish the removal and subsequent reinstallation of the float assembly, follow the appropriate instructions provided on **page 6** for the SureSite type and mounting configuration you have selected.

Caution

Make sure that the tank is depressurized and that liquid has been emptied prior to removal of the float assembly.

SureSite with Side Connections (Alloy, Mini and Plastic)

The float assembly can be removed without disturbing the mounting of the SureSite unit to the tank.

1. Carefully remove the end cap (access to the float assembly) which may be retained by bolts, NPT threads or held in place by setscrews. The float assembly should be resting on the end cap as it is being lowered. Support the float assembly while setting the end cap aside.

Note: For units supplied with top float access, the float assembly must be extracted from the top of the weldment by engaging the hooking ring provided on the top of the float.

2. Withdraw the float assembly from the unit, exercising caution not to damage the float. Note the “**TOP**” indication marking on the float assembly.
3. Wipe down the weldment and the float assembly with a clean, lint-free cloth.
4. Carefully reinsert the float assembly into the weldment, ensuring that the “**TOP**” indication marking on the float assembly is positioned in the same manner as when it was removed.
5. Remove the old gasket or O-ring from the end cap assembly and replace it with a new gasket or O-ring.
6. With the new gasket or O-ring properly positioned, reassemble the end cap assembly to the weldment. Tighten the end cap or secure flange fasteners, using the proper recommended torque value, as supplied in **Figure A -page 5**.

SureSite with Top and Bottom Connections (Alloy, Mini and Plastic)

The SureSite unit should be adequately supported when removing it from the tank.

1. Disconnect the top and bottom flange/socket or NPT connections.
2. Remove any other fasteners that retain the unit and/or support bracket(s) to the tank.
3. Remove the SureSite unit from the tank, while avoiding any motion that will cause damage to the float assembly.
4. With the SureSite placed in a horizontal position on a level surface, remove the end cap or flange and withdraw the float assembly from the unit; noting the relative position of the portion of the float assembly marked “**TOP**”.
5. Wipe down the weldment and the float assembly with a clean, lint-free cloth.
6. Carefully reinsert the float assembly into the bottom of the float chamber or weldment, ensuring that the “**TOP**” indication marking on the float assembly is positioned the same as when it was removed.
7. Remove the old gasket or O-ring from the end cap assembly and replace it with a new gasket or O-ring.
8. With the new gasket or O-ring properly positioned, reassemble the end cap assembly to the bottom of the weldment. Tighten the end cap or flange bolts securely, using the proper recommended torque value, as supplied in **Figure A, page 5**.
9. Complete installation of the unit by following the **Installation Instructions for Standard SureSites (Page 3, Steps 7, 8 and 9)**.

SureSites Mounted on Top of Tank

The construction of top-mounted SureSites varies with the material selected, and each requires a slightly different procedure than those preceding for “wipe-down”. It is advisable to mark or index mating flanges and other parts so that the relative positions of the components are maintained upon reassembly.

Alloy

1. Remove the attaching bolts that secure the SureSite unit to the top of the tank. **Lift the SureSite vertically** from the tank and set it aside on a level work area, **in horizontal position**. **Exercise caution** so that the float assembly will not be dented or damaged. Remove any gasket material from the tank and SureSite mounting flanges.
2. Remove the attaching bolts securing the external weldment (with the attached flag assembly) to the mounting flange that was secured to your tank, and carefully remove the weldment and gasket from the float chamber, taking care not to damage the sphere-shaped magnet carrier.
3. While lightly supporting the magnet carrier, remove the upper (first) cotter pin attaching it to the float rod. Set the magnet carrier and cotter pin aside.
4. Remove the lower (second) cotter pin from the float rod and set it aside.
5. Withdraw the float and float rod from the bottom of the float chamber.
6. Wipe the inside of the float chamber and the exposed float assembly with a clean, lint-free cloth.
7. After completing the “wipe-down” cleaning, the unit can be reassembled.
8. Obtain new gaskets for: a) Installation between the weldment and float chamber¹, and b) Installation between the mounting flange² of your tank and that of the unit. Obtain new cotter pins for the float rod.
9. Insert the float assembly and rod into the float chamber, passing the float rod up through the opening in the mounting flange. Secure the rod to the float chamber by installing a cotter pin in the lower (second) hole and securing it. Reinstall the magnet carrier to the float rod. Insert and secure a cotter pin in the upper (first) hole to retain it.
10. Complete the remainder of the reassembly and installation by reversing the process described in Steps 1 and 2. Refer to **Figure A, page 5** for recommended torque values for bolts. Use a new gasket: a) Between the weldment and mounting flange of the float chamber, and b) Between the mounting flange of your tank and that of the SureSite unit.

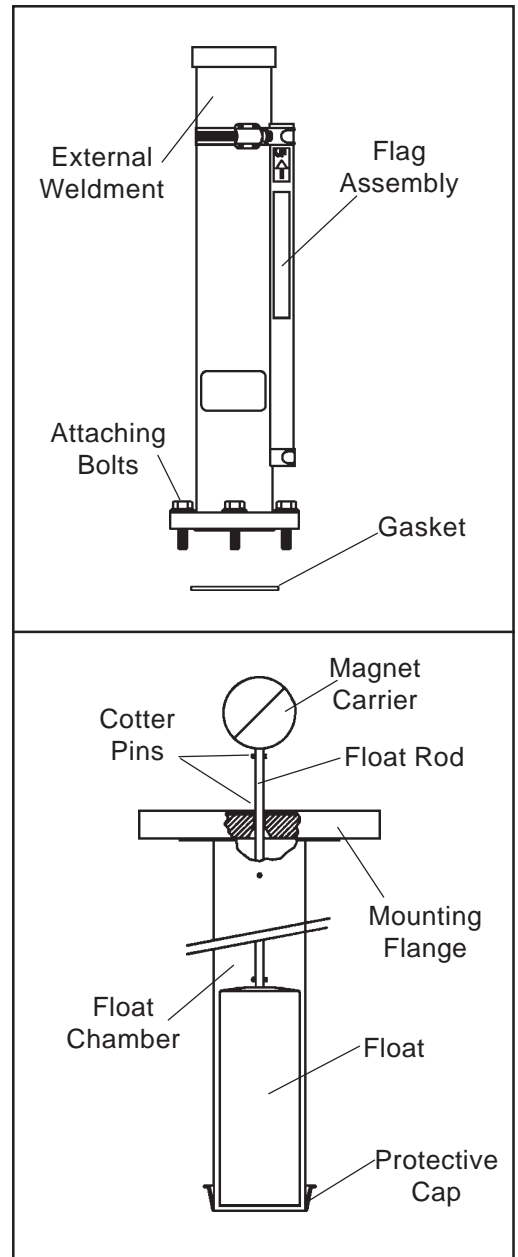

¹ Contact Gems Sensors for spare or replacement parts

² Customer-Supplied

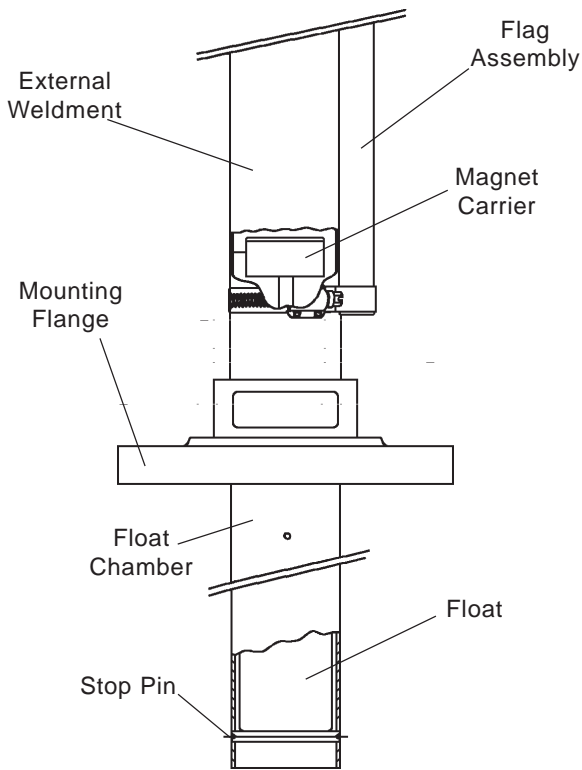

Hold the float vertical. A paper clip will attach to the magnet to show its position. Adjust the magnet position by gently tapping the end of the float.

Plastic

1. Remove the attaching bolts that secure the SureSite unit to the top of the tank and lift the indicator unit (with its float chamber) vertically from the tank. Set it aside on a level work area, horizontally. Handle the float assembly with care to prevent damage. Remove any gasket material from the tank and SureSite mounting flanges.
2. Unscrew and remove the stop pin from the bottom of the float chamber.
3. Carefully withdraw the float, float rod, and attached magnet assembly from the bottom of the float chamber.
4. Wipe the inside of the float chamber and the exposed float assembly with a clean, lint-free cloth.
5. After completing the "wipe-down" cleaning, the unit can be reassembled. Obtain a new gasket for installation between the mounting flange of your tank and that of the SureSite unit. Prepare the mating surfaces for reassembly.
6. Insert the float assembly and rod into the float chamber, passing the magnet assembly and float rod up through the bottom of the float chamber. Secure the float assembly and rod to the float chamber by reinstalling the stop pin.

Basic Float Part No. 807100
(Liquid Specific Gravity Range: 0.8 to 1.2)

Float Part Number	Liquid Specific Gravity	"X" Dimension	Float Part No. W/Lift Ring
85206	0.8	5"	810919
83453	0.9	4.5"	810917
85208	1	4"	810916
85209	1.2	3.312"	810915
84158	0.85	4.75"	810918

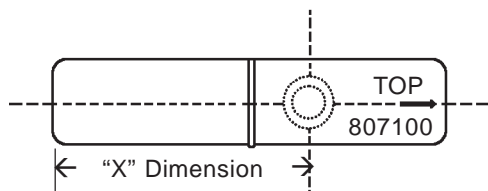

Basic Float Part No. 807200
(Liquid Specific Gravity Range: 1.5 to 3.8)

Float Part Number	Liquid Specific Gravity	"X" Dimension	Float Part No. W/Lift Ring
88111	1.9	2"	810928
801708	1.5	2.6875"	810927

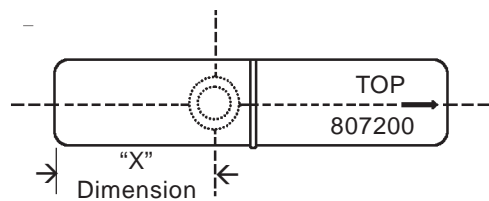

Troubleshooting

Condition	Possible Cause	Solution
No change in Media Level Indication	No Float	Install float
	Float sticking, due to contamination in the fluid level	Clean the float and weldment
	Float attracted, due to external ferrous materials within close proximity.	Remove the ferrous materials from close proximity
	The float is damaged	Replace the float
	Port is blocked	Remove blockage
Incorrect Fluid Level Indication	Float attracted, due to contamination in the media	Clean the float and weldment
	Float sticking, due to external ferrous materials within close proximity	Remove the ferrous materials from close proximity
	The float is damaged	Replace the float
	The float is upside down	Invert the float
Incorrect Color Indicating Fluid Level	Flag assembly is upside-down. (The wrong color is indicating the liquid level)	Rotate the flag assembly 180 degrees (with the end marked "TOP" uppermost)

Note: Increased viscosity increases the response time of the SureSite indicator

Warnings/Cautions

1. The SureSite Magnetic Level Indicator must be maintained and installed in strict accordance with this Instruction Bulletin. Failure to observe this warning could result in serious injuries or damages.

2. The liquids to be monitored must be compatible with the materials of construction. Specifications of these materials will be provided upon request.



Gems Sensors Inc.
 One Cowles Road
 Plainville, CT
 06062.1198

tel 860.747.3000
 fax 860.747.4244

SureSite[®] Magnetic Liquid Level Indicator

Installation, Operation and Maintenance
Bulletin No. 177664-2 (Rev. B)



Section 2: Switches

Operation

The SureSite Switch Module, available for use with the SureSite Magnetic Liquid Level Indicator, is a sealed assembly containing a magnetically actuated "latching-reed" switch assembly. The reed switch is actuated by the movement of the magnet contained in the SureSite float. The design of the reed switch permits the switch module to perform as either a "normally open" or "normally closed" switch. When installed with the lead wires (or junction box) installed at the top, the switch module is "normally open" and the reed switch will close with the rising fluid level in the tank; remaining closed until a falling fluid level in the tank causes the float to drop below the indicating position, opening the reed switch. When installed with the lead wires (or junction box) at the bottom, the switch module is "normally closed" and the reed switch will open with the rising fluid level in the tank, and remain open until a falling fluid level in the tank causes the float to drop below the indicating position, closing the reed switch. (See sketches below)

For electrical schematics of the switch module, please refer to the Wiring Diagrams, located on pages 5 and 6.

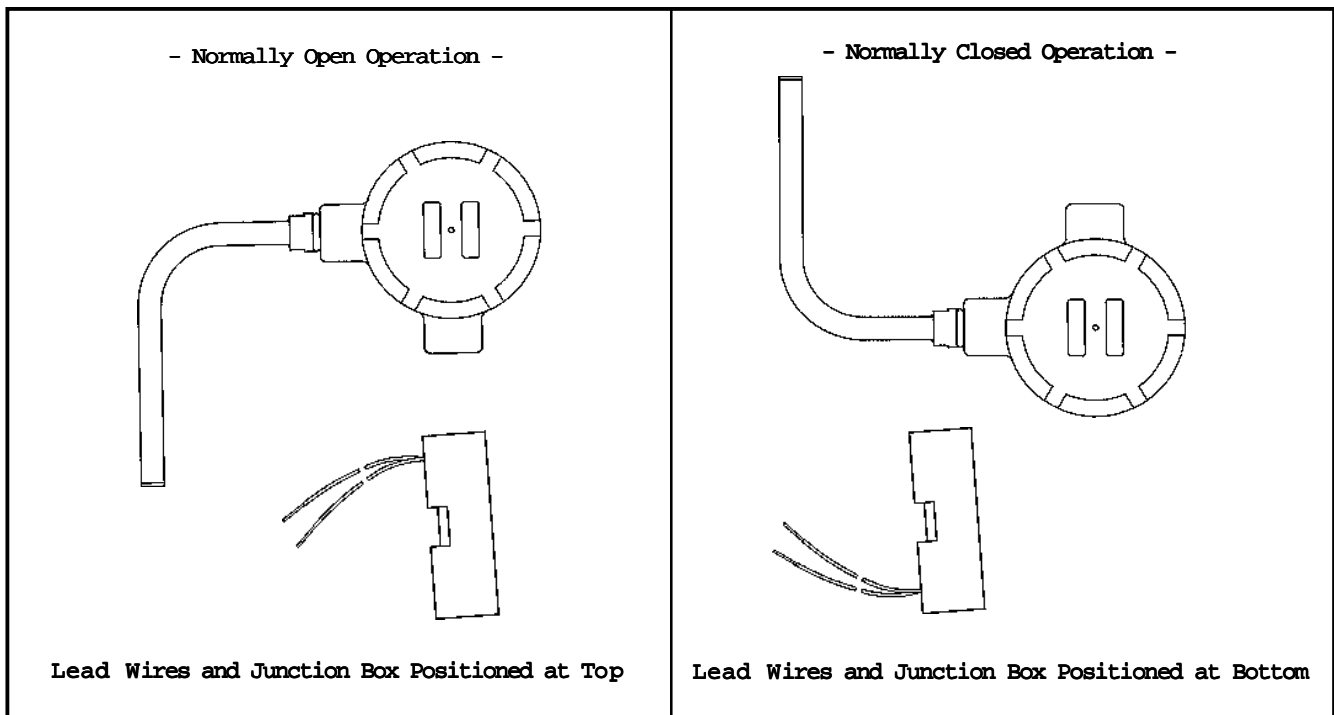

Installation

General: The SureSite switch module must be mounted 180° opposite the flag assembly of the SureSite Magnetic Level Indicator and within its operating range. The installation of the switch module varies, depending on the switch module housing and the type of SureSite Magnetic Level Indicator. The chart on the next page is intended to provide an overview of the various switch modules and to indicate which diagram(s) should be referred to for installation instructions.

Installation (Cont.)

If it is necessary to locate two switch-points close together, two switch modules can be positioned side-by-side and located 180° opposite of the flag assembly, as shown.

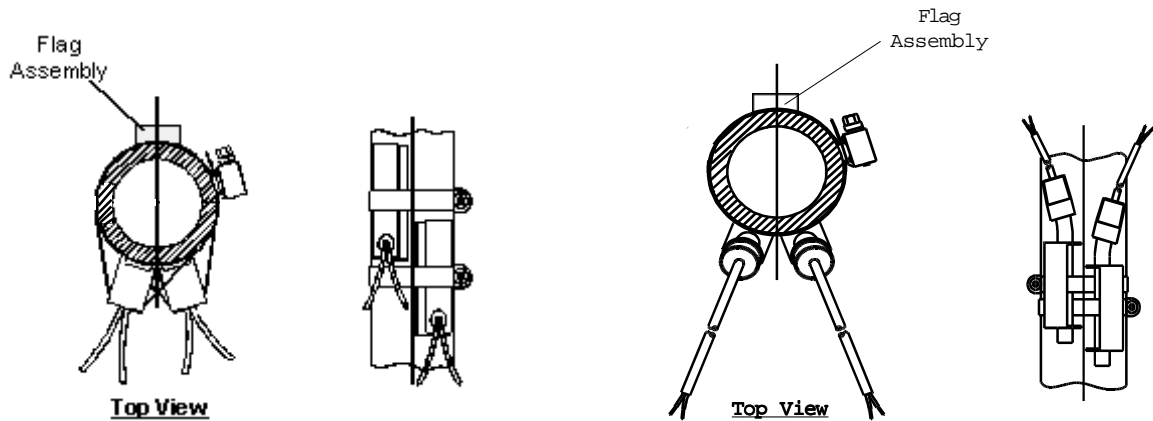

Switch Modules

Part Number	SureSite Type	Switch Rating / Configuration	Max. Fluid Temp (°F / °C)	Mounting Hardware			Switch Housing Material
				Bracket / Spacer Block	Clamp	J-Box	
Standard							
85350	Standard	20 VA SPST, N.O. or N.C.	300 / 148	N/A	N/A	N/A	Polysulfone
86435	Standard	20 VA SPST, N.O. or N.C.	300 / 148	N/A	Incl.	N/A	Polysulfone
86567	Mini	20 VA SPST, N.O. or N.C.	300 / 148	N/A	Incl.	N/A	Polysulfone
87480	Mini / Plastic	20 VA SPST, N.O. or N.C.	300 / 148	N/A	N/A	N/A	Polysulfone
80469	Plastic	20 VA SPST, N.O. or N.C.	300 / 148	N/A	N/A	N/A	Polysulfone
High Temperature							
83140	All	20 VA SPST, N.O. or N.C.	750 / 398	Incl.	N/A	N/A	316 SS
83150	All	20 VA SPST, N.O. or N.C.	750 / 398	Incl.	N/A	N/A	316 SS
84320	All	20 VA SPDT, N.O. or N.C.	750 / 398	Incl.	N/A	N/A	316 SS
803430	All	220 VDC, 5 Amp	750 / 398	Incl.	Incl.	Incl.	316 SS
Explosion-Proof / High Temperature							
83100*	All	120 VDC, 10 Amp	750 / 398	Incl.	Incl.	Incl.	316 SS
83110*	All	24 VDC, 10 Amp	750 / 398	Incl.	Incl.	Incl.	316 SS
83120*	All	20 VA SPST, N.O. or N.C.	750 / 398	Incl.	Incl.	Incl.	316 SS
83130*	All	20 VA SPST, N.O. or N.C.	750 / 398	Incl.	Incl.	Incl.	316 SS
84330	All	20 VA SPDT, N.O. or N.C.	750 / 398	Incl.	Incl.	Incl.	316 SS

*** Factory Mutual approved for:**

Explosion-proof for Class 1, Division 1, Groups C & D and Class 1, Division 2, Groups B, C & D; Dust ignition proof per Class 2, Division 1, Groups E, F & G and suitable for Class 3, Division 1, Hazardous Location, Indoors (Ref. File #J.I. 0A8A3.AE). Also CSA certified for Class 1, Division 1, Groups B, C & D (Ref. Files IR22666-22 and IR22666-24).

Note

For Standard Unit installation instructions, see Mounting Diagram "A"

For all other part numbers listed above, see Mounting diagram "B", "C" or "D"

- Mounting Diagrams -

Diagram A

Standard SureSite®

Switch Part Numbers

80469, 85350, 86435, 86567, 87480

1. Position the switch module 180° from the flag assembly and within indicating range.
2. Slide the switch clamp between the flag assembly and the weldment of your SureSite Magnetic Level Indicator.
3. With the switch module located at the desired fluid level, tighten the clamp screw securely; not to exceed a torque of 10 lb-inches.
4. Connect the switch module leads to the load circuit.

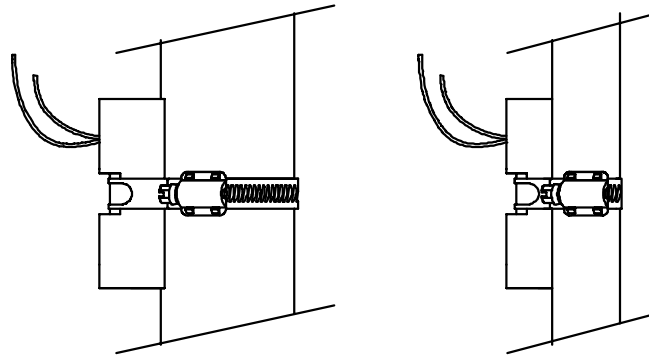

Mini SureSite®

Diagram B

1. Position the switch module 180° from the flag assembly and within indicating range.
2. Slide the tabs of the switch clamps between the flag assembly and the weldment of the Mini SureSite Magnetic Level Indicator; wrapping the retaining screw-end around the upper and lower stem of the switch, as shown.
3. With the switch module located at the desired fluid level, tighten the clamp screw securely; not to exceed a torque of 120 lb-inches.
4. Connect the switch module leads to the load circuit.

Switch
Part Numbers
83100, 83110,
83120, 83130.
83140, 83150,
84320, 84330

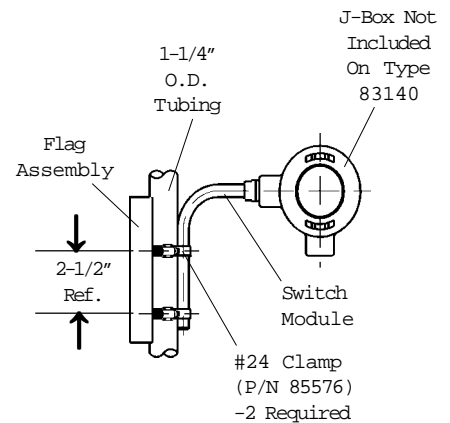

Switch
Part Numbers
83150, 84320

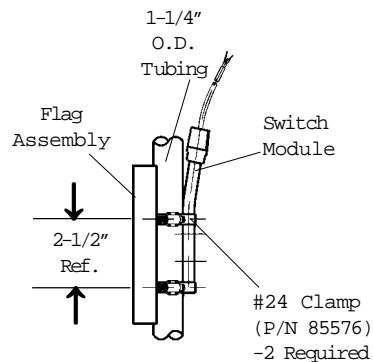

Mounting Diagrams (Cont.)

Diagram C

1. Slide the switch into the support bracket.
2. Position the switch module 180° from the flag assembly and within indicating range.
3. Slide the switch clamp between the switch bracket and the stem of the switch, then between the flag assembly and the weldment of your SureSite Magnetic Level Indicator.
4. With the switch module located at the desired fluid level, tighten this clamp screw securely, not to exceed a torque of 120 lb-inches.
5. Connect the switch module leads to the load circuit.

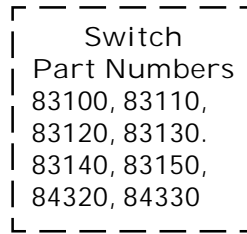

Alloy SureSite®

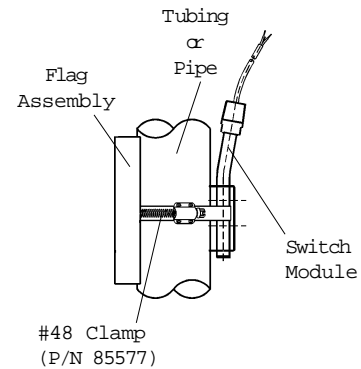
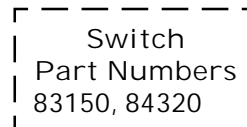
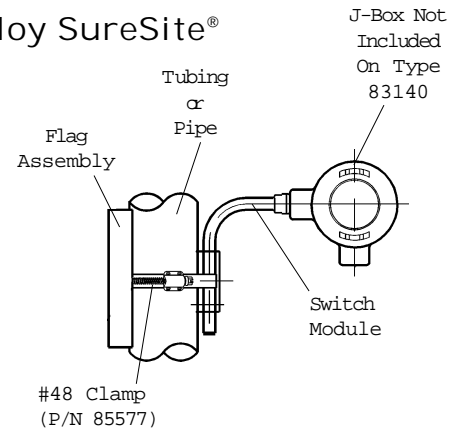
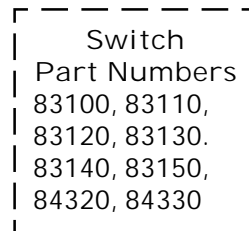
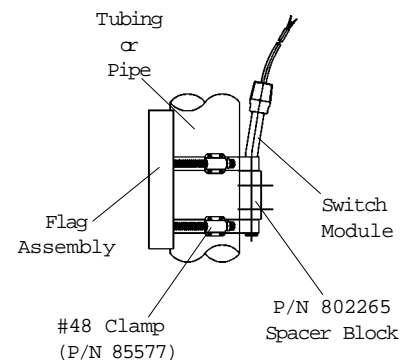
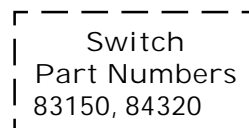
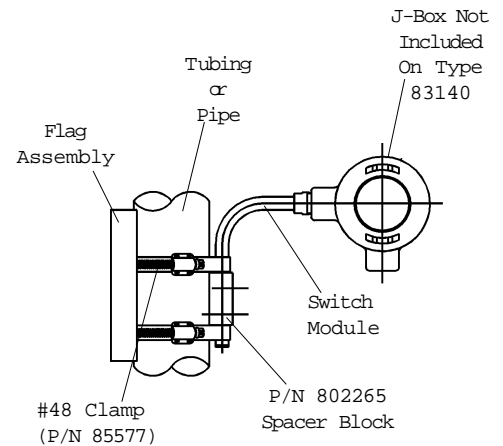

Diagram D

1. Slide the switch into the plastic spacer block.
2. Position the switch module 180° from the flag assembly.
3. Slide the tabs of the switch clamps between the flag assembly and the weldment of your SureSite Magnetic Level Indicator, wrapping the retaining screw-ends around the stem of the switch, above and below the spacer block and the desired indication/activation level, as shown.
4. With the switch module located at the desired fluid level, tighten both clamp screws securely, not to exceed a torque of 120 lb-inches.
5. Connect the switch module leads to the load circuit.



Plastic SureSite®



Wiring Diagrams

Part Numbers

80469, 87480, 85350, 86435, 86567

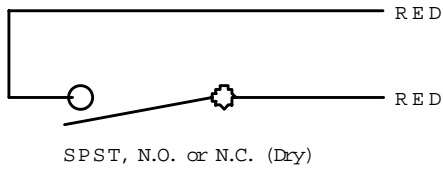

Part Number 83100

- Dry Condition -

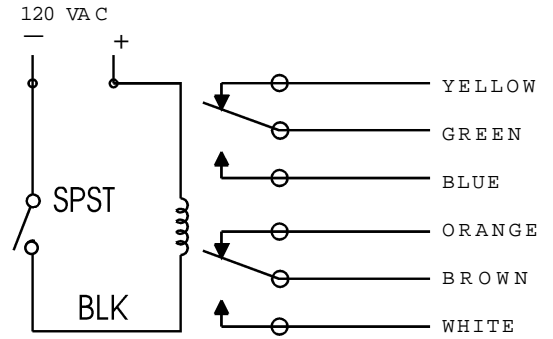

Part Number 83110

- Dry Condition -

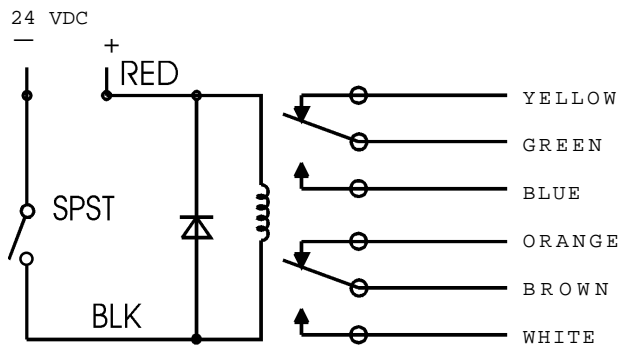

Part Numbers

83120, 83140, 83150

- Dry Condition -

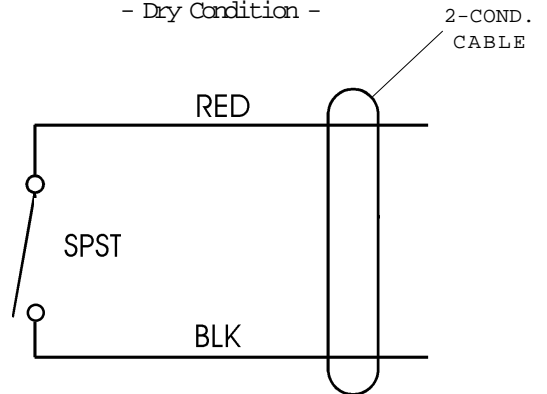

Part Number 83130

- Dry Condition -

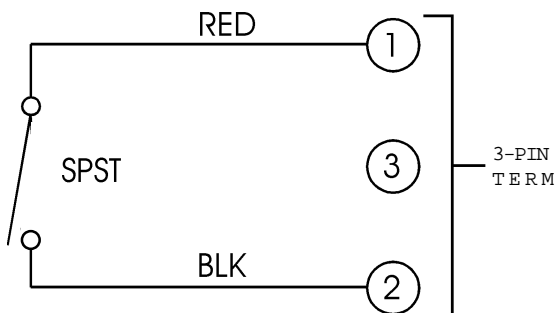

Part Numbers

84320, 84330 DPDT

- Dry Condition / J-Box at Top -

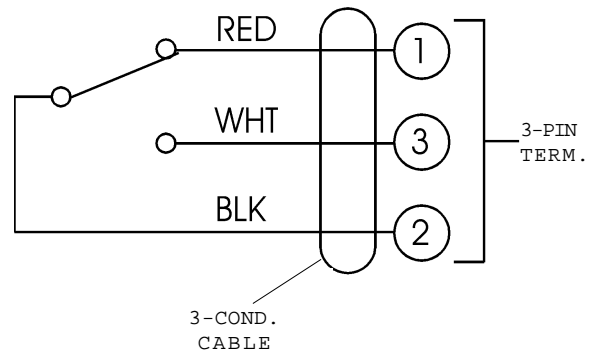

Wiring Diagrams (Cont.)

Part Numbers

84320, 84330

- Dry Condition / J-Box at BIM -

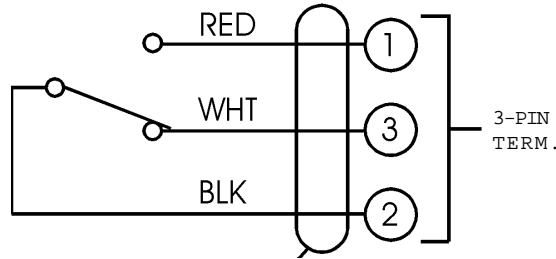

3-COND.
CABLE

Switch Module Troubleshooting

Condition	Possible Cause	Solution
Intermittent Switching or Not Latching	Positioned Incorrectly	Reposition Switch Modules
	Switch not in Indicating Range	Reposition Switch Modules
	Incorrect Mounting Hardware	See Appropriate Mounting Diagram
	Incorrect Wiring Between Switch & Load	Correct Wiring (See Wiring Diagrams)
Switch Not Switching Switch Remains Open or Closed At All times	Positioned Incorrectly	Reposition Switch Modules
	Switch Not in Indicating Range	Reposition Switch Modules
	Incorrect Mounting Hardware	See Appropriate Mounting Diagram
	Incorrect Wiring Between Switch & Load	Correct Wiring (See Wiring Diagrams)
	Switch Rating Exceeded	Replace Switch (See Appropriate Rating Diagram)



Gems Sensors Inc.
One Cowles Road
Plainville, CT
06062.1198

tel 860.747.3000
fax 860.747.4244

Rotational Positioning (Cont.)

4. Outline the location of the transmitter and flag assembly on the SureSite housing.
5. Loosen the clamps around the flag assembly to allow for installation of the transmitter clamps. The flag assembly clamps should only be loosened enough to permit the transmitter clamps to be inserted between the flag assembly and the SureSite housing.
6. Install the transmitter and loosely clamp it in the location outlined in step 4.
7. Tighten flag assembly clamps. Do not exceed 5 lb-inches.
8. Verify that the red (maximum) and blue (minimum) indication marks are centrally located between the ends of the flag assembly.
9. Using the alignment guide, verify that the SureSite transmitter is positioned correctly in relation to the flag assembly. Reposition if necessary.
10. Tighten the transmitter clamps securely. Do not exceed 5 lb-inches.
11. Wire to appropriate signal conditioner/converter or controller.

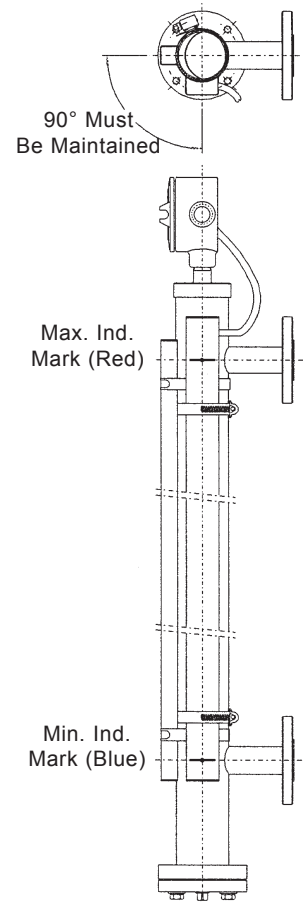

- Figure B -

Note

To ensure continuous electrical output, the transmitter must lay flat against the SureSite housing over the entire length.

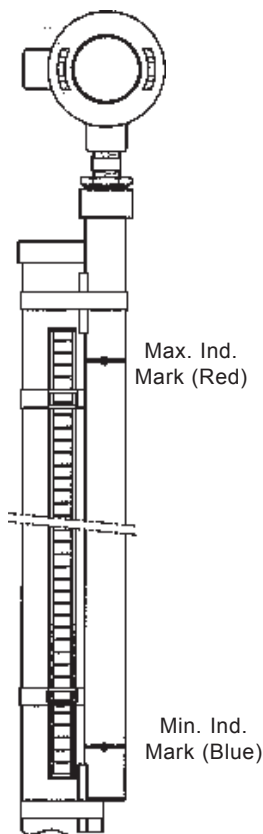

- Figure C -

High Temp/Explosion-Proof Transmitter

Rotational Positioning

1. The high temperature/explosion-proof SureSite transmitter is externally mounted and positioned either to the left or right of the flag assembly, per **Figure A**.
2. Using the flag assembly as a reference, position the high temperature/explosion-proof SureSite transmitter using the red (maximum) and blue (minimum) indication marks. Each indication mark should be placed approximately the same distance from the top and bottom of the flag assembly.
3. The high temperature/explosion-proof SureSite transmitter is secured to the SureSite Magnetic Level Indicator housing using two mounting clamps. One clamp is positioned at the top of the high temperature/explosion-proof transmitter and the other clamp is positioned at the bottom. Position clamps as shown in the **Figure C**.
4. Tighten clamps securely.

2-Piece Transmitter - High Temperature/Explosion-Proof

Rotational Positioning

1. The 2-section high temperature/explosion-proof SureSite transmitter is externally mounted to the left or right of (and adjacent to) the flag assembly and is positioned with the transmitter standoffs against the SureSite weldment or housing. The lower section mounts to the right of the flag assembly - the upper section mounts to the left; as indicated in **Figure D**.
2. Taking the upper section of the high temperature/explosion-proof SureSite transmitter and using the flag assembly as a reference, position the transmitter section so that the red (maximum) indication mark is one 1" **below** and **to the left** of the top of the SureSite flag assembly.
3. Loosely clamp the upper section of the high temperature/explosion-proof SureSite transmitter by placing one clamp around the top and bottom of the transmitter section at the same location as the transmitter standoffs. (**See Figure D**)
- 4) Taking the lower section of the high temperature/explosion-proof SureSite transmitter and using the flag assembly as a reference, position the transmitter section so that the blue (minimum) indication mark is 1" above and to right of the bottom of the SureSite flag assembly.
5. Loosely clamp the lower section of the high temperature/explosion-proof SureSite transmitter by placing one clamp around the top and bottom of the transmitter section at the same locations as the transmitter stand-offs. (**See Figure D**)
6. If the blue (minimum) indication mark of the upper section and the red (maximum) indication mark of the lower section (the centered indication marks) are not aligned as shown in **Figure D**, reposition both sections by sliding each section of the transmitter up or down equally.
7. With the centered indication marks aligned, verify that the red (maximum) indication mark of the upper section and the blue (minimum) indication mark of the lower section are centrally located between the top and bottom of the SureSite flag assembly.

Note
If the red (maximum) and blue (minimum) indication marks are not centrally located between the top and bottom of the SureSite flag assembly, reposition the transmitter accordingly.

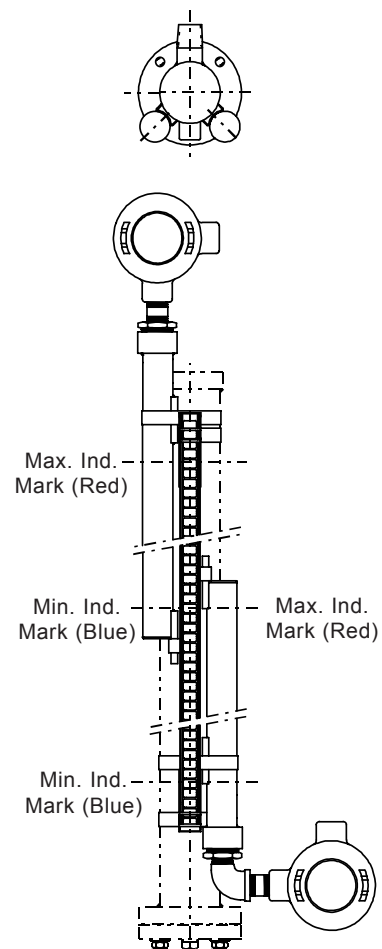

- Figure D -

Reminder

The centered indication marks must remain aligned as shown for continuous indication.

8. Tighten clamps securely.
9. Wire per supplied diagram. Due to many different wiring combinations for the 2-piece high temperature/explosion-proof SureSite transmitter, **the wiring diagram is supplied with the unit.** If using a Gems explosion-proof SureSite transmitter, use the appropriate wiring method (per N.E.C. Article 500).

Mini-Transmitter

Rotational Positioning

1. The Mini-SureSite transmitter is externally mounted and positioned 180° from the SureSite flag assembly, per **Figure E**.
2. Before installing the Mini-SureSite transmitter on your SureSite Magnetic Level Indicator, outline the location of the flag assembly on the indicator housing.
3. Remove the existing flag assembly clamps from the flag assembly, one at a time. Replace these clamps with the new flag assembly/transmitter clamps provided. When replacing the old flag assembly clamps with the new flag assembly/transmitter clamps, the Mini-Transmitter should be loosely clamped 180° from the flag assembly. The new clamp secures both the Mini-SureSite transmitter and the SureSite flag assembly.
4. With all the clamps replaced, reposition the flag assembly to the previously outlined location. Also, vertically position the Mini-SureSite transmitter so that the red (maximum) and blue (minimum) indication marks are centrally located between the top and bottom of the SureSite flag assembly.
5. Verify that the Mini-SureSite transmitter is 180° from the flag assembly. Reposition as necessary.
6. Tighten the flag assembly/transmitter clamps securely. Do not exceed 5 lb-inches.

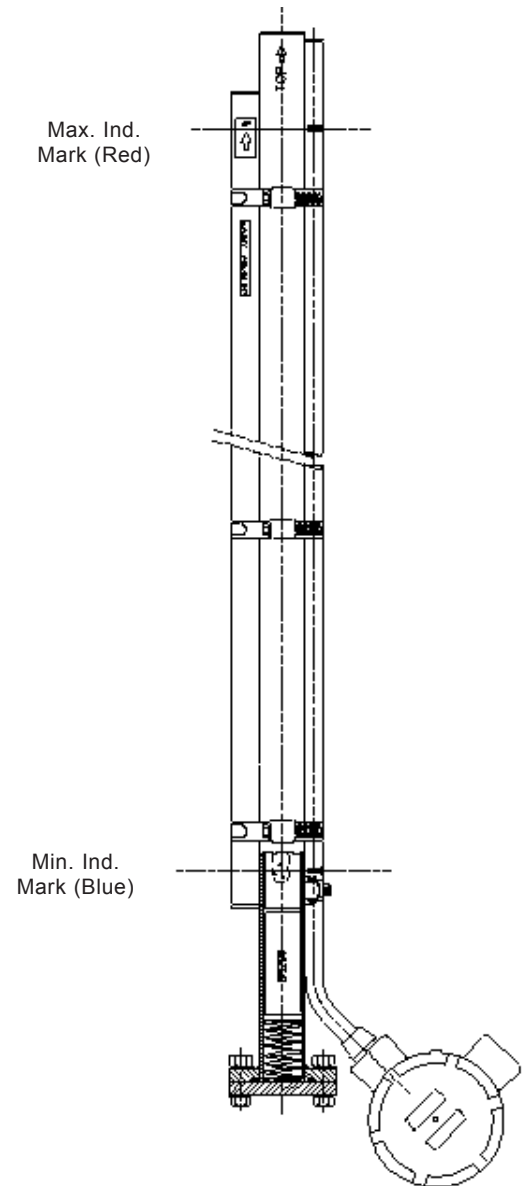

- Figure E -

Service

Because the transmitter is not field-serviceable, the unit must be returned for repair or replacement.

Transmitter Troubleshooting

Condition	Possible Cause	Solution
No Output or Loss of Signal	Positioned Incorrectly	Reposition Transmitter (See appropriate installation section)
	Incorrect Wiring Between Transmitter & Load	Correct Wiring (See wiring diagrams)
	Transmitter Faulty*	Repair or Replace Transmitter

* To Determine if Your Transmitter is Faulty:

1. Disconnect the transmitter from the signal conditioner/converter or controller.
2. With an ohmmeter, check the total resistance between the red and black wire of the high temperature/explosion-proof Suresite transmitter. The resistance should read typically between 1200W and 1600W.
 - If the resistance between the red and black wires reads as an open, contact Gems Sensors for further assistance.
 - If the resistance total between the red and black wires is verified, the **SureSite float must be removed** from the SureSite magnetic level indicator. If you are unable to remove the float from your Suresite, you **must remove the transmitter from the Suresite housing**.
3. With an ohmmeter, check the resistance between the red and white & the black and white wires of the high temperature/explosion-proof SureSite transmitter. The resistance between both sets of wires should read $\infty \Omega$. If you are reading any resistance across either set of wires other than $\infty \Omega$, contact Gems Sensors for further assistance.
4. If all of the resistance readings and the transmitter's position are verified as correct, but the SureSite transmitter is still not operating correctly, contact Gems Sensors for further assistance.

If Your 2-Piece Transmitter is Faulty, Follow the Steps Below to Determine Which Section to Replace:

1. Disconnect the upper section from the lower section of the 2-piece high temperature/explosion-proof Suresite transmitter.
2. With an ohmmeter, check the total resistance between the red and black wires of the upper section of the 2-piece high temperature/explosion-proof SureSite transmitter. The resistance should read typically between 600 Ω and 800 Ω . If the resistance between the red and black wires reads as an open, contact Gems Sensors for further assistance.

If the resistance total between the red and black wires on the upper section is verified:

3. With an ohmmeter, check the total resistance between the red and black wires of the lower section of the 2-piece high temperature/explosion-proof SureSite transmitter. The resistance should read typically between 600 Ω and 800 Ω . If the resistance between the red and black wires reads as an open, contact Gems Sensors for further assistance.

If the resistance total between the red and black wires on the lower section is verified:

4. The SureSite float **must be removed from the Suresite magnetic level indicator**. If you are unable to remove the float from your SureSite, **you must remove the transmitter from the SureSite housing**.
5. With an ohmmeter, check the resistance between the red & white and the black & white wires of the upper section of the 2-piece transmitter. The resistance between both sets of wires should read $\infty \Omega$. If you are reading any resistance across either set of wires other than $\infty \Omega$, contact Gems Sensors for further assistance.

If the resistance total between the red and black wires on the upper section is verified:

6. With an ohmmeter, check the resistance between the red & white and the black & white wires of the lower section of the 2-piece transmitter. The resistance between both sets of wires should read $\infty \Omega$. If you are reading any resistance across either set of wires other than $\infty \Omega$, contact Gems Sensors for further assistance.
7. **If all of the resistance readings and the transmitter's position are verified as correct, but the SureSite transmitter is still not operating correctly, contact Gems Sensors for further assistance.**



Gems Sensors Inc.
One Cowles Road
Plainville, CT
06062.1198

tel 860.747.3000
fax 860.747.4244

Magnetic Liquid Level Indicator

Installation, Operation and Maintenance
 Bulletin No. 177664-4 (Rev. E)



Section 4: Signal Conditioners

Signal conditioners provide a regulated output (voltage or current) when used with Gems SureSite transmitters. The signal conditioner is housed within a junction box with two or three ports. The ports allow for mounting and customer wiring. Your signal conditioner's part number can be found on the identification plate located on the back of the junction box. Your unit has the operating and electrical characteristics indicated in the chart (for reference purposes) below:

Part Number	Output Signal	Input Voltage Source	Conditioner Accuracy With Transmitter	Output Signal Loading	Transient Voltage Protection
86156	0 to 5 VDC	8 to 24 VDC	± 0.4% of Full Scale or ± 1" - - Whichever is greater	4K Ohms/V Max (.25 mA)	Metal Oxide Varistor Rated @ 30 VDC
85997	0 to 12 VDC	15 to 30 VDC		2K Ohms/V Max (.5 mA)	Metal Oxide Varistor Rated @ 38 VDC
86157*	0 to 12 VDC	20 to 30 VDC			
86158	4 to 20 mA	10 to 40 VDC	± 1.0% of Full Scale or ± 1" - - Whichever is greater	Range: 100 - 1200 Ohms	Metal Oxide Varistor Rated @ 68 VDC 250 Amps
112300	4 to 20 mA				
152800	4 to 20 mA				

***Note**

1. Lower Alarm Point for P/N 86157 varies. The default setting is 2% to 50% of full scale.
2. Upper Alarm Point for P/N 86157 varies. The default setting is 50% to 98% of full scale.

General Note

Converter/signal conditioner Part Numbers **86158, 112300, and 152800** require calibration to maintain the accuracy of SureSite transmitter readings. Converter calibration can be accomplished, using your transmitter or a transmitter simulator.

Calibration is simplified when using a transmitter simulator in place of the SureSite transmitter. Because the output voltage of the signal conditioner is stepped down to a fixed DC voltage, the transmitter and the transmitter simulator act as identical electrical loads, as interpreted by the converter. For the purpose of calibration, rotating the shaft (wiper) of the transmitter simulator performs the same function as moving the SureSite float up and down inside the weldment. In each case, the changing resistance will provide the proper output to calibrate the signal conditioner. A transmitter simulator has been supplied with your converter/signal conditioner.

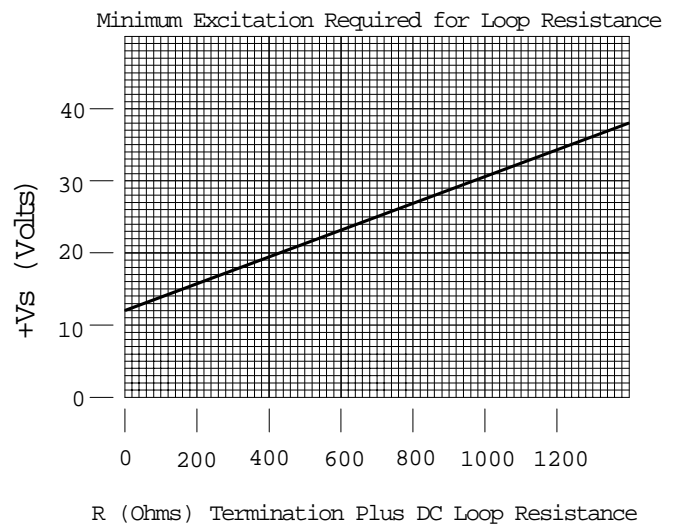

Installation Precautions and Preparations

With the exception of P/N 112300, all signal conditioners are typically installed on the SureSite magnetic level indicator at the factory. For those units so designated, the customer will have to provide electrical grounding, with an effective resistance of 1W or less. Please refer to the Wiring Diagram(s) for your particular signal conditioner part number. Calibration of the signal conditioner can be accomplished using your SureSite transmitter or the transmitter simulator (supplied).

Signal Conditioner Part Numbers 86156 (0 to 5 VDC) and 85997 (0 to 12 VDC)

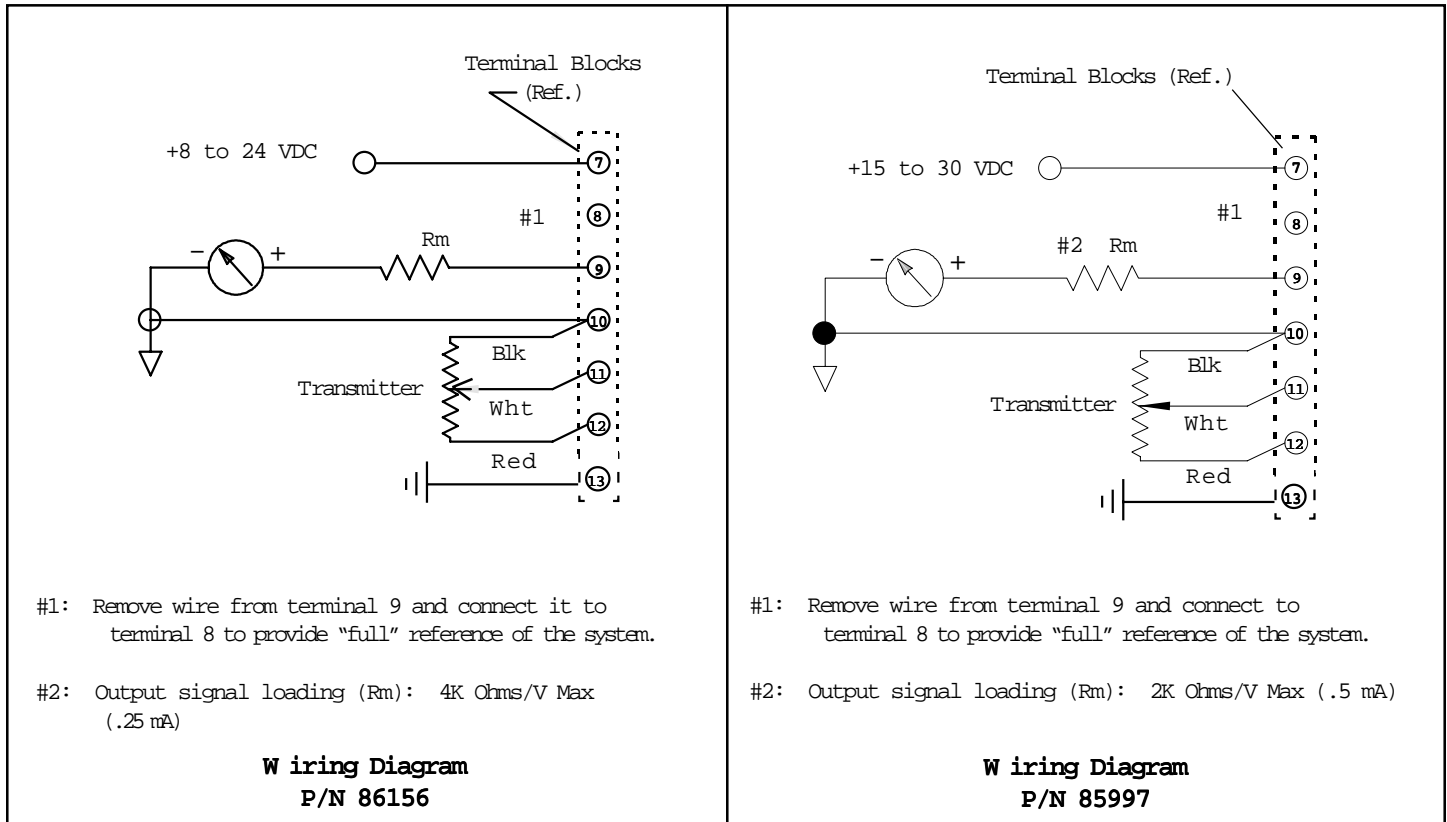

Installation Specifics

The signal conditioner is typically installed on the SureSite magnetic level indicator at the factory. If your signal conditioner was purchased separately, you may use one of the 1/2" FNPT parts for mounting.

Calibration Requirements

None. Both of these units are calibrated at the factory.

Part Number 86157, 0 to 12 VDC

This unit contains two relays intended to provide a high and low alarm signal for process control. These relays are K1 and K2, respectively, in the wiring diagram. Standard alarm functions are K1 (High Alarm) and K2 (Low Alarm). Other configurations are available upon request. Unless specified otherwise, the trip-point for the Low Alarm relay has been set at 5% of full scale, while that of the High Alarm relay has been set at 95% of full scale.

Signal Conditioner Part Numbers 86157 (0 to 12 VDC)

- Wiring Diagram -

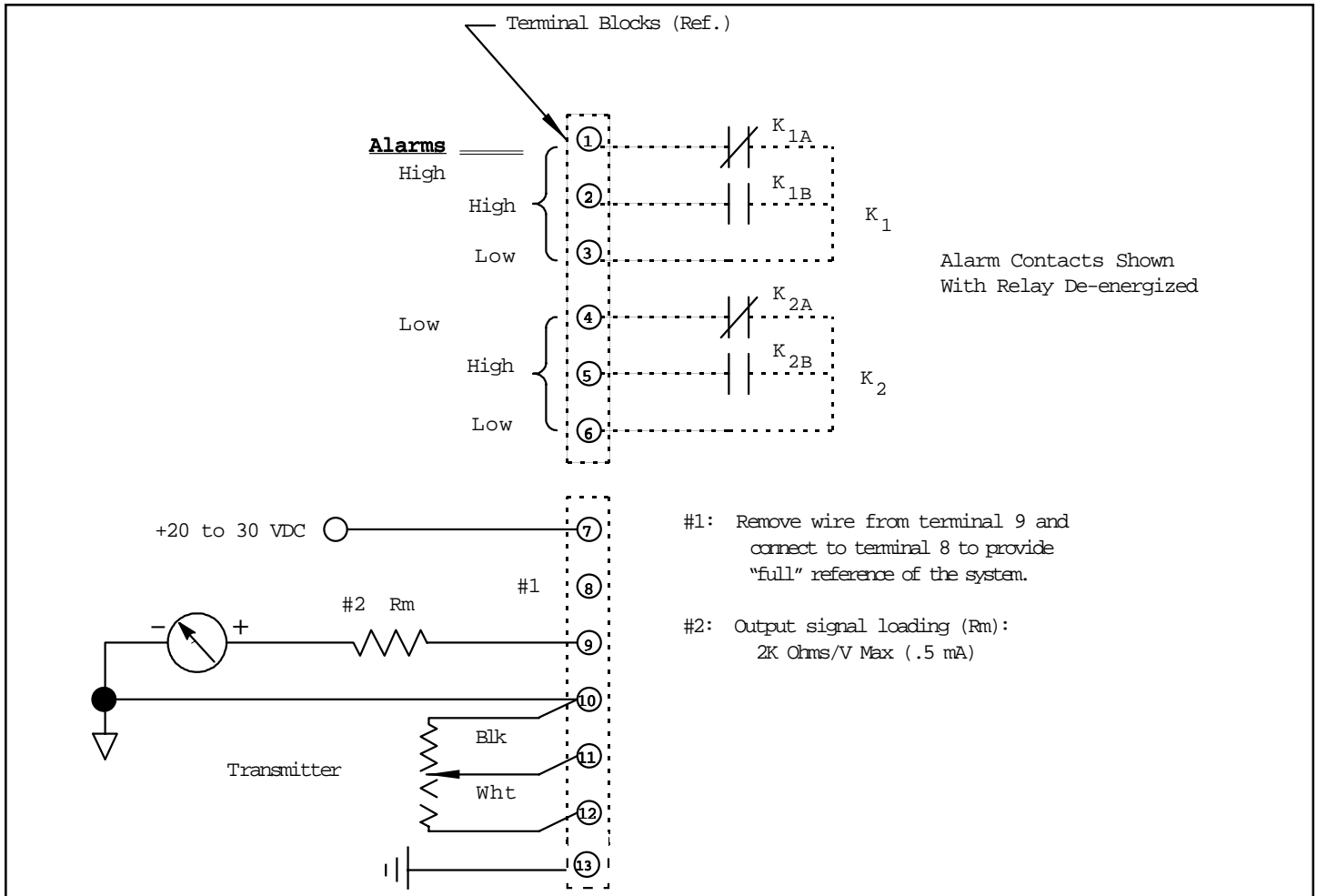

Installation Specifics

The 86157 Signal Conditioner is typically installed on the SureSite magnetic level indicator at the factory. If your signal conditioner has been purchased separately, you may use one of the 1/2" FNPT ports for mounting.

Calibration Requirements

None. This unit is calibrated at the factory. If it is necessary to change the high and/or low alarm settings, you may follow the procedure provided below.

Alarm Calibration Procedure (P/N 86157)

The alarm trip-points are adjusted by means of two separate twenty-turn potentiometers, through either the upper or lower 50% of the indicated range. The approximate set-point adjustment can be made by counting the number of revolutions from the end-stops of the pots. As a general 'Rule of Thumb,' you may expect 2.5% of the indicated range per turn. After you have established the desired trip-point(s) for the alarm relay(s), the adjusting knob(s) may be fixed with a small amount of RTV or other semi-permanent material.

Signal Conditioner Part Numbers 86158 and 152800 (4 to 20 mA)

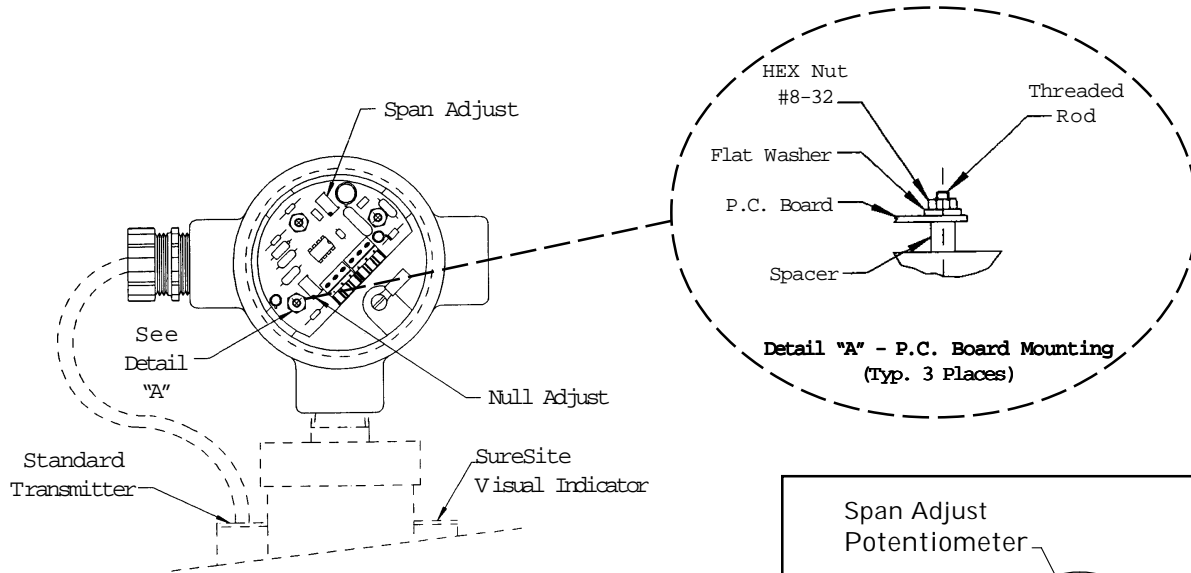

This Unit Incorporates a Linear Voltage to Current Converter

Calibration Requirements

The calibration procedure should be conducted with a potentiometer (transmitter simulator) which has a resistance value of 1.0 k Ohm , minimum, to a maximum of 2.5 k Ohm . The transmitter simulator supplied with the signal conditioner has an adjustment range of 0 to 1000 ohms.

Calibration Procedure

(**Note**: Calibration should be performed with the signal conditioner disconnected from the SureSite transmitter)

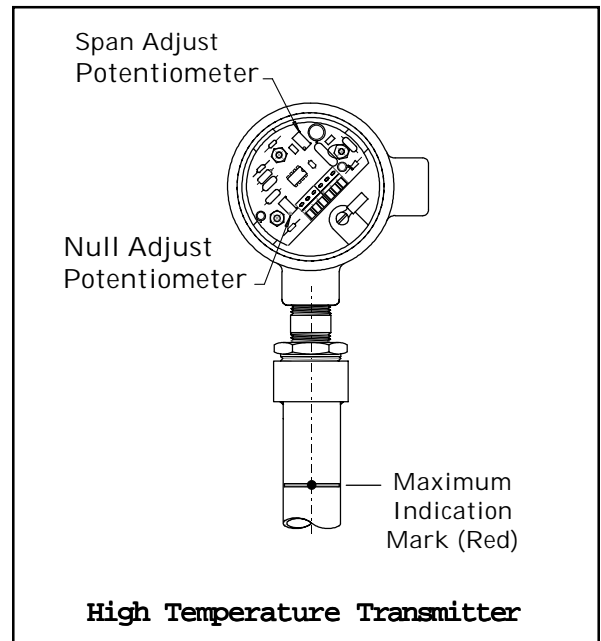

1. Make the connections as shown in the calibration wiring diagram with the power supply turned off
2. Set and apply the D. C. power supply voltage at 24 VDC, with a 250 Ohm load resistance, as shown.
3. Adjust the span and null potentiometers at approximately mid-range.
4. Set the transmitter/simulator potentiometer adjusting screw to its fully clockwise position, for a maximum indication on the digital multimeter (DMM).
5. With the span adjust potentiometer (see illustration), set the output current to 20 mA.
6. Turn the transmitter/simulator potentiometer adjusting screw to its fully counter-clockwise position, for a minimum indication on the DMM.
7. With the null adjust potentiometer, set the output current to 4 mA.
8. Repeat steps #4 through #7 for the final fine adjustment. No further adjustments will be required.
9. After calibration, the converter/signal conditioner can be mated permanently to the transmitter assembly. Any adjustments for null and span (4mA & 20 ma), due to D. C. loop resistance, are achieved by adjusting the potentiometer screws

Signal Conditioner Part Numbers 86158 (4-20mA)

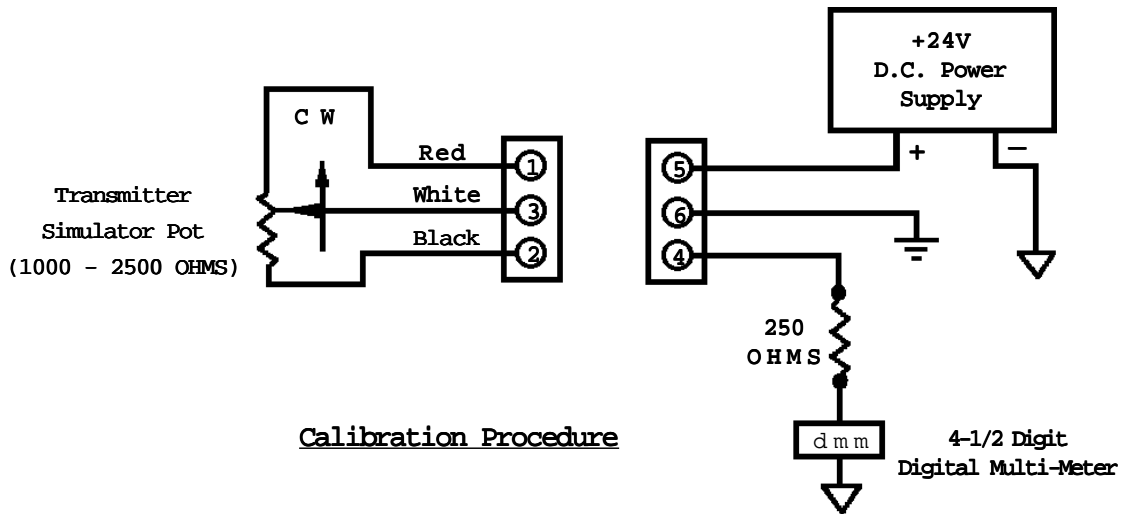

Calibration Procedure

- Wiring Diagram -

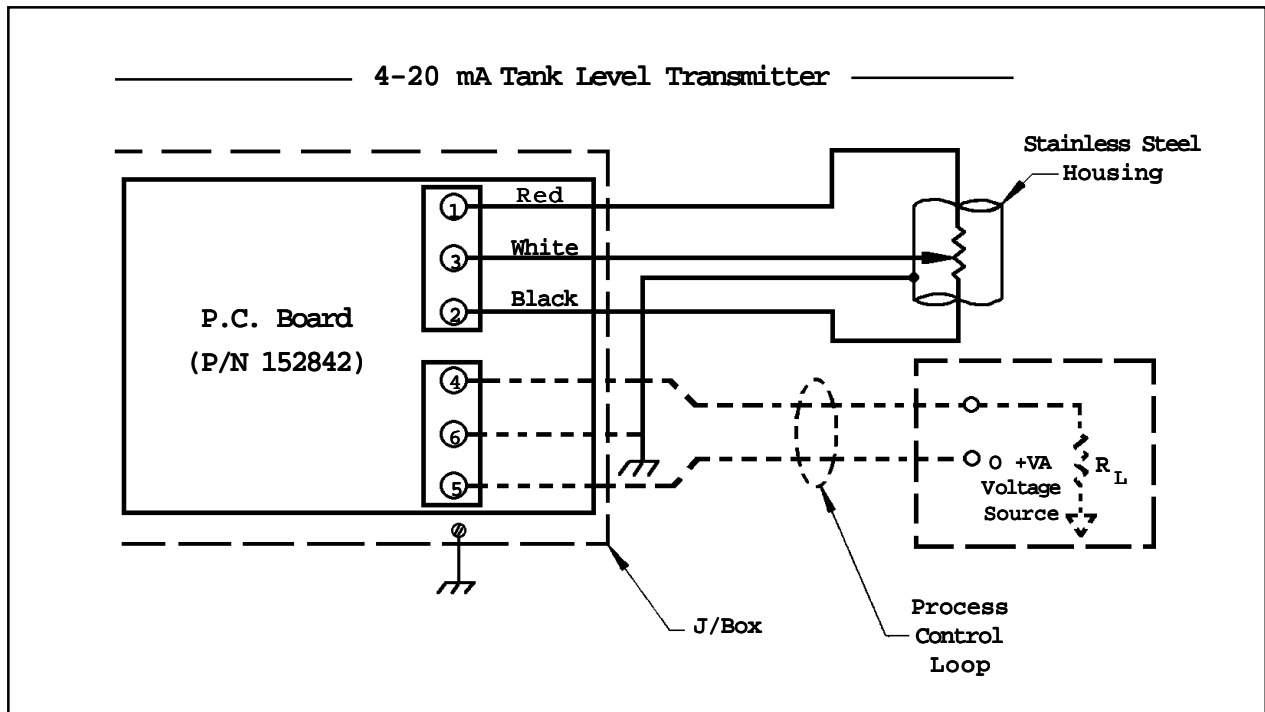

Installation Specifics

The signal conditioner is typically installed on the Gems SureSite magnetic level indicator at the factory. If your signal conditioner was purchased separately, you may use one of the FNPT ports for mounting.

Signal Conditioner Part Number 112300 (4 to 20 mA)

- Panel Mounted Version -

This unit incorporates a Linear Voltage to Current Converter.

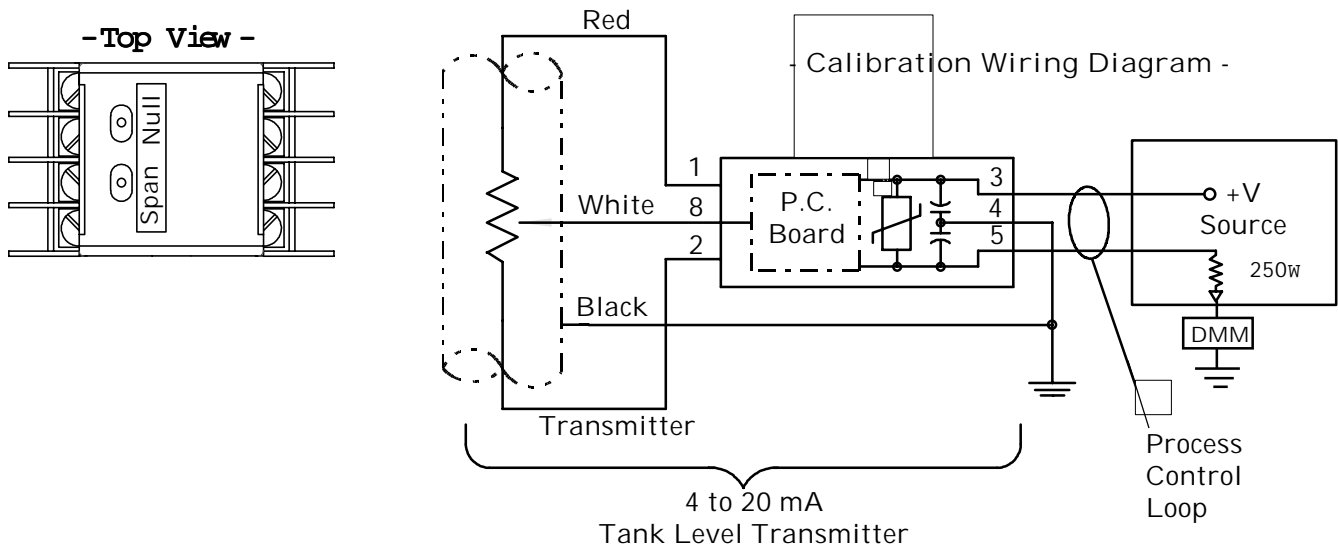

Calibration Requirements

The calibration procedure should be conducted with a potentiometer (transmitter simulator) which has a resistance value of 1.0 kW minimum to a maximum of 2.5 kW . The transmitter simulator is supplied.

Calibration Procedure

Note: Calibration should be performed with the signal conditioner disconnected from the SureSite transmitter.

1. Make connections as shown in the Calibration Wiring Diagram with the power supply turned off.
2. Set and apply the D.C. power supply voltage at 24 VDC with a 250w load resistance, as shown in the diagram.
3. Adjust both the span and null potentiometers at approximately mid-range.
4. Set the transmitter/simulator potentiometer adjusting screw to its fully clock-wise position, for a maximum indication on the digital multimeter (DMM).
5. With the span adjust potentiometer screw (see "Top View" diagram above), set the output current to 20.00 mA.
6. Turn the transmitter/simulator potentiometer adjusting screw to its fully counter-clock-wise position, for a minimum indication on the DMM.
7. With the null adjust potentiometer (see "Top View" diagram above), set the output current to 4.00 mA.
8. Repeat steps 4 through 7 for the final fine adjustment. No further adjustments will be required.
9. After calibration, the converter/signal conditioner can be installed at the desired location. Any adjustments for null and span (4.00 & 20.00 mA), due to DC loop resistance, are achieved by adjusting the potentiometer screws.

Installation Specifics

The panel-mount design of this unit permits remote installation. For mounting purposes, it is possible to remove the body of the unit from the terminal base. This permits the terminal base to be installed on two 3/16" studs or with two 3/16" screws, at the slotted holes provided. After installation of the terminal base, reinstall the body of the unit in its socket.

- Wiring Diagram -

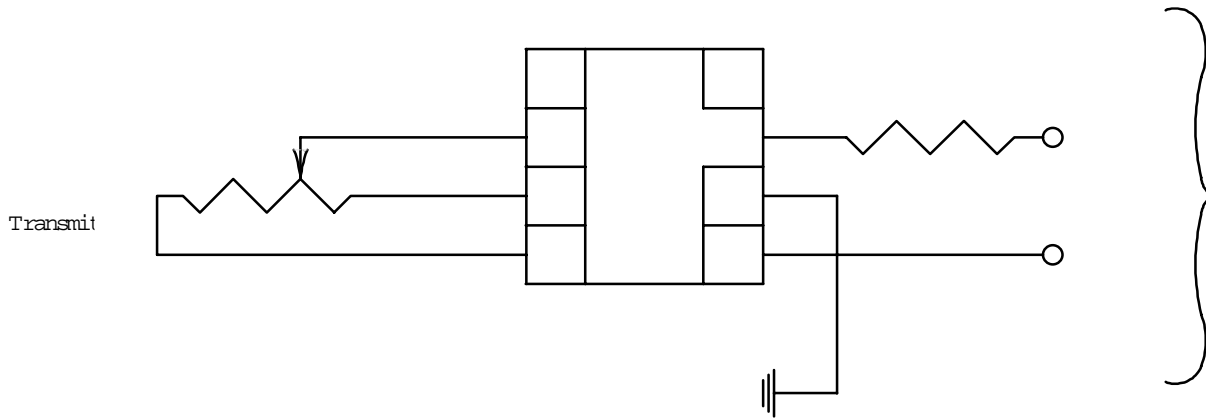

- Signal Conditioner Troubleshooting -

Condition	Possible Cause	Solution
No Output	Loose or Improperly Connected Wires At Terminal Screws	Correct Connections
	Incorrect Wiring	Correct Wiring (See Wiring Diagrams)
	Transmitter Positioning Incorrect	See SureSite Transmitter Troubleshooting Section
High or Low Alarm Points Not Alarming at Desired Setpoints	Alarm Setpoints Incorrect	Recalibrate Alarm Setpoints (See Calibration Procedure)



Gems Sensors Inc.
 One Cowles Road
 Plainville, CT
 06062.1198

tel 860.747.3000
 fax 860.747.4244



SureSite^a Magnetic Liquid Level Indicator

Installation, Operation and Maintenance
Bulletin No. 177664-5

Section 5: Power Supplies

The SureSite power supply is designed to provide regulated DC input voltage when only AC voltage is available. This DC voltage can be used to supply the required input voltage to the Gems signal conditioner. Designed to accept a nominal 115 VAC or 230 VAC input (depending upon the unit ordered), the power supply's output is 50 mA at 24 VDC, nominal. The power supply has an operating temperature range of -15°C to +70°C (-5°F to +158°F) and its output is thermally and short circuit protected against damage.

Installation

In most cases, the power supply is attached and wired to the signal conditioner at the Factory; requiring only to be wired to your AC voltage source. You may utilize any of the junction box 1/2" NPT ports to mount the unit in a fixed position.

1. With the power turned off and the circuit disabled, remove the cover from the junction box housing of the power supply, and remove the thread protector from the port you have selected for wiring. (See Installation Diagram).

2. Run your voltage source wiring through the appropriate strain relief device₁ and into the junction box.

- Typical Installation -

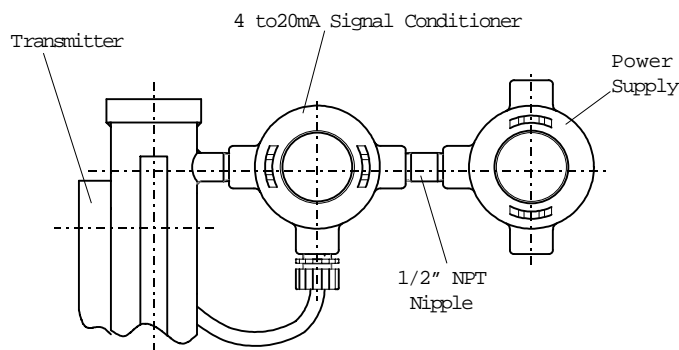

- Wiring Diagrams -

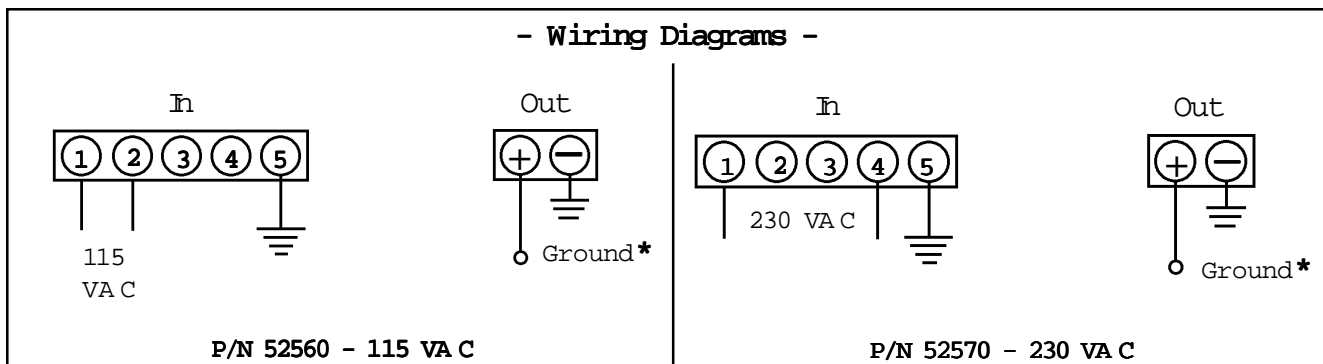

*Negative output is not junction box grounded. A ground may be made, if required.

- For 115 VAC Input Only
Connect your wiring to terminals 1 and 2 of Terminal Block-1. (See the wiring diagram for your power supply.)
- For 230 VAC Input Only
Connect your wiring to terminals 1 and 4 of Terminal Block-1. (See the wiring diagram for your power supply.)

₁The Strain Relief Device is **Not** Factory-Supplied

5. If your power supply is remotely mounted and has not been connected to the signal conditioner:

a) Remove the thread protector(s) from the ports

b) Connect the lead wires to the power supply output terminals. Run the wires through appropriate strain relief device(s)₁ and into the signal conditioner. (See the "Power Supply to Signal Conditioner" sketch.)

c) See the appropriate signal conditioner wiring diagram for proper wiring instructions.

6. Reinstall the cover with its required O-ring on the junction box.

7. Enable the circuit and turn power on.

Power Supply to Signal Conditioner

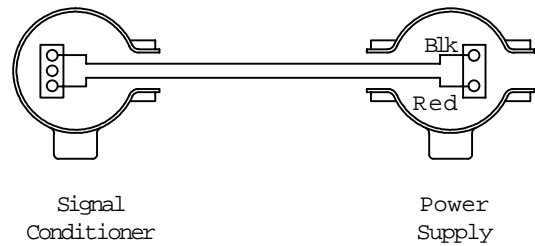

Power Supply Troubleshooting

Condition	Possible Cause	Solution
24 VDC Output Bad	Input Voltage Not Correct	Apply the Proper Input Voltage -115 VAC or 230 VAC
	Incorrect Wiring Between Signal Conditioner and Power Supply	Correct Wiring (See Appropriate Wiring Diagrams)
	Loose or Improperly Connected Wires at Terminal Screws	Correct Connections

₁The Strain Relief Device is **Not** Factory-Supplied





SureSite[®] Magnetic Liquid Level Indicator

Installation, Operation and Maintenance
Bulletin No. 177664-6
Rev. B

Section 6: Indicating Scale

This Indicating Scale provides a numerical readout of the liquid level in the tank, in addition to the visual level displayed by the flag assembly. The indicating scale is mounted alongside the flag assembly with special clamps. The scale is normally graduated in inches and feet, but may be graduated in other dimensional or volumetric units. Scales that have an overall length of more than 24 inches will be provided in two or more sectional lengths.

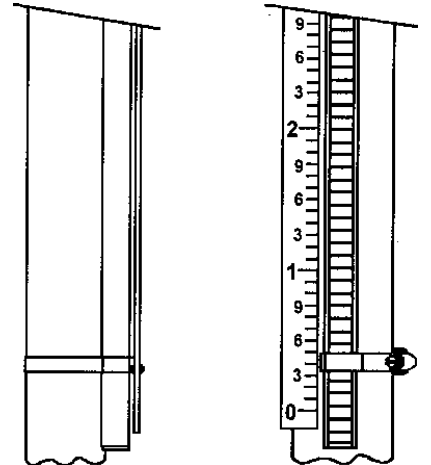

Side View

Front View

Installation

Scales ordered with the SureSite Magnetic Level Indicator are factory-installed. If ordered separately, please follow the instructions below.

Mounting

The scale is simply installed on your SureSite Magnetic Level Indicator using the bracketed clamps supplied.

1. Attach the scale onto the SureSite Magnetic Level Indicator, wrapping the clamps around the flag assembly and the weldment.
2. Tighten the clamps securely, with a torque not to exceed 5 lb.-inches.



Gems Sensors Inc.
One Cowles Road
Plainville, CT
06062.1198

tel 860.747.3000
fax 860.747.4244

SureSite® Magnetic Liquid Level Indicator

Installation, Operation and Maintenance
Bulletin No. 177664-7 (Rev A)



Section 7: Insulation Blankets

Installation

Insulation Blankets are provided to minimize the possibility of personal injury and heat loss. Blankets have been designed for various SureSite Magnetic Level Indicators and mounting configurations, as indicated below:

Indicator Type	Mounting Configuration	Description
Mini	Top and Bottom Mount	1-Piece
Mini	Side Mount	2-Piece
Standard	Top and Bottom Mount	1-Piece
Standard	Side Mount	3-Piece
Standard	Side Mount with Switches	4-Piece

Mini-SureSite - Top and Bottom Mount (1-Piece Blanket)

The optional Heat Trace cable should be installed according to the supplied instructions prior to wrapping the Insulation Blanket around the SureSite, as described below:

1. Wrap the long section of the Insulation Blanket around the SureSite Magnetic Level Indicator so that the area on either side of the flag assembly is covered. The flag assembly alone remains visible.
2. Using non-ferrous lock-wire, secure the Insulation Blanket to the Mini-SureSite at intervals of approximately 12 inches (30 cm), as shown in the illustration. Twist the wire ends to secure. (See Figure A)

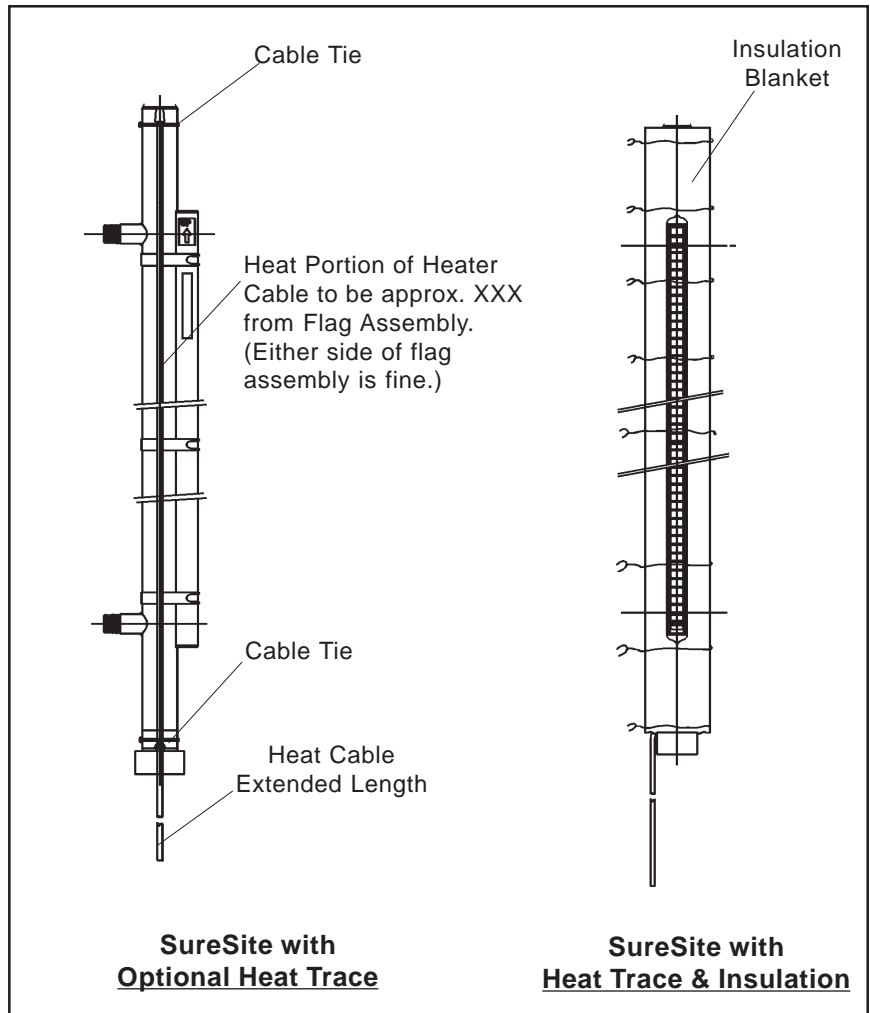

- Figure A -

**Mini-SureSite
Side-Mount
(2-Piece Blanket)**

The optional Heat Trace Cable should be installed according to the supplied instructions prior to wrapping the insulation blanket around the SureSite, as described in the instructions below:

1. Wrap each of the two long sections of the insulation blanket around half of the SureSite Magnetic Level Indicator so that the areas between the side connections and the flag assembly are covered. The flag assembly remains visible.
2. Using non-ferrous lock-wire, secure the insulation blanket to the Mini-SureSite at intervals of approximately 12 inches (30 cm), as shown in **Figure A**. Twist the wire ends to secure.

**Standard SureSite
Top and Bottom Mount
(1-Piece Blanket)**

The optional heat trace Cable should be installed according to the supplied instructions prior to wrapping the insulation blanket around the SureSite, as described below.

1. Wrap the long section of the insulation blanket around the SureSite, so that the area on either side of the flag assembly is covered. The flag assembly alone remains visible.
2. Using non-ferrous lock-wire, secure the insulation blanket to the SureSite, as shown in the illustration below (**Figure B**), at the “hog-ring” locations. Twist the wire ends to secure, drawing the insulation blanket together, surrounding the flag assembly.

**Standard SureSite
Side-Mount
(3-Piece Blanket)**

The optional heat trace cable should be installed according to the supplied instructions prior to wrapping the insulation blanket around the SureSite, as described below:

1. Wrap the long section of the insulation blanket around the SureSite, between the side connectors and position the edges so that the flag assembly alone remains visible.
2. Using non-ferrous lock-wire, secure the insulation blanket to the SureSite, as shown in the **Figure B**, at the “hog-ring” locations. Twist the wire ends to secure, drawing the insulation blanket together, surrounding the flag assembly.
3. The remaining two pieces (the top and bottom collars) are to be wrapped around the SureSite, and likewise secured as in step 2. See **Figure B** for clarity.

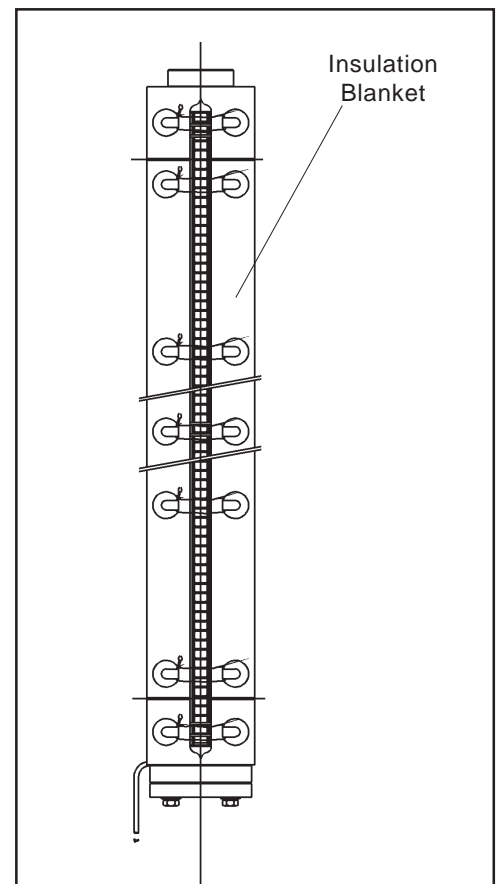

- Figure B -

Standard SureSite (4-Piece Blanket)

The optional heat trace cable, should be installed according to the supplied instructions prior to wrapping the insulation blanket around the SureSite, as described below:

1. Wrap each of the two long sections of the insulation blanket around half of the SureSite, so that the areas between the side connectors and the flag assembly are covered. The flag assembly alone remains visible.
2. Using non-ferrous lock-wire, secure the insulation blanket to the SureSite, as shown in the **Figure C**, at the "hog-ring" locations. Twist the wire ends to secure, drawing the insulation blanket together, surrounding the flag assembly.
3. The remaining two pieces (the top and bottom collars) are to be wrapped around the SureSite, and likewise secured, as in step 2. See **Figure C** for clarity.

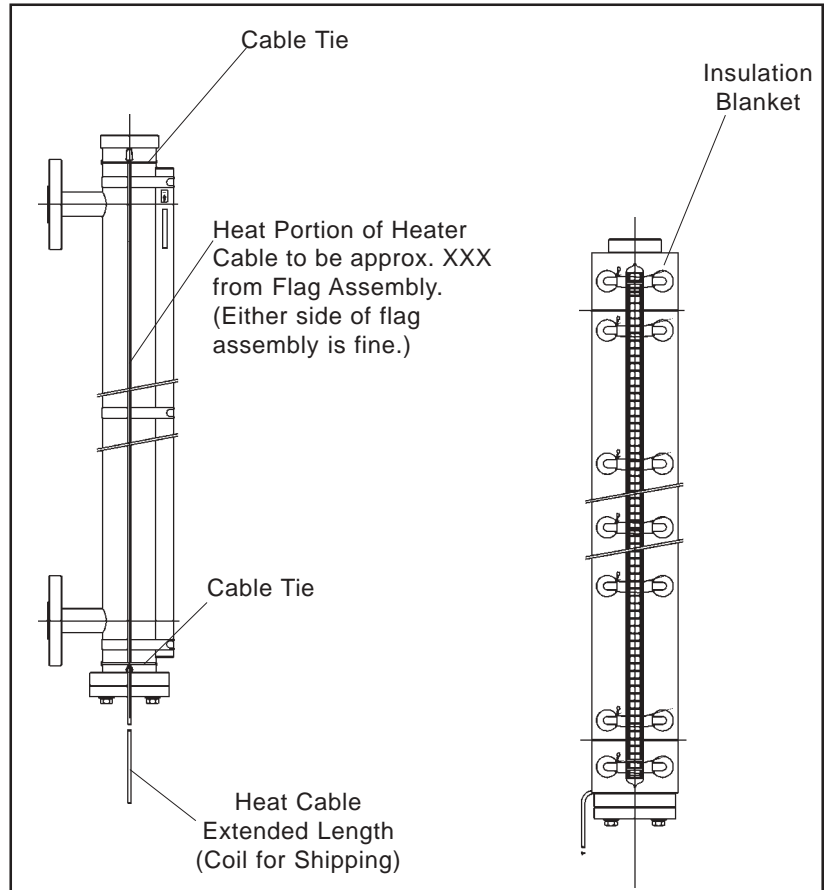

- Figure C -



Gems Sensors Inc.
One Cowles Road
Plainville, CT
06062.1198

tel 860.747.3000
fax 860.747.4244

SureSite® Magnetic Liquid Level Indicator

Installation, Operation and Maintenance

Bulletin No. 177664-8 (Rev A)

Section 8: Heat Trace



Operating Principle

The Heat Trace is a self-regulating length of heating cable intended for use with the SureSite Magnetic Level Indicator. The cable is provided with a nominal six-foot (183 cm) power lead length. The heater cable portion (or length) is typically rated at 10 Watts per foot, operating at 120 Volts. Power consumption is directly proportional to the length ordered.

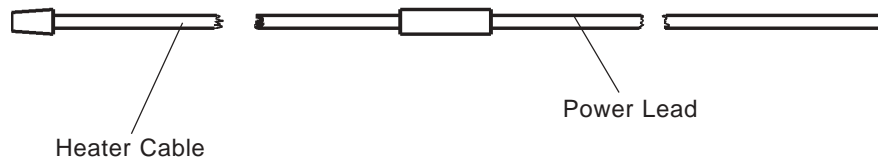

Installation

The Heat Trace may be installed on either side of the flag assembly.

1. Position the Heat Trace heater cable end at the top of the SureSite and approximately 90 degrees from the flag assembly, as shown.
2. Using two cable ties (supplied), attach the Heat Trace at the top and bottom of the SureSite unit, as shown.
3. Attach power leads to voltage source.

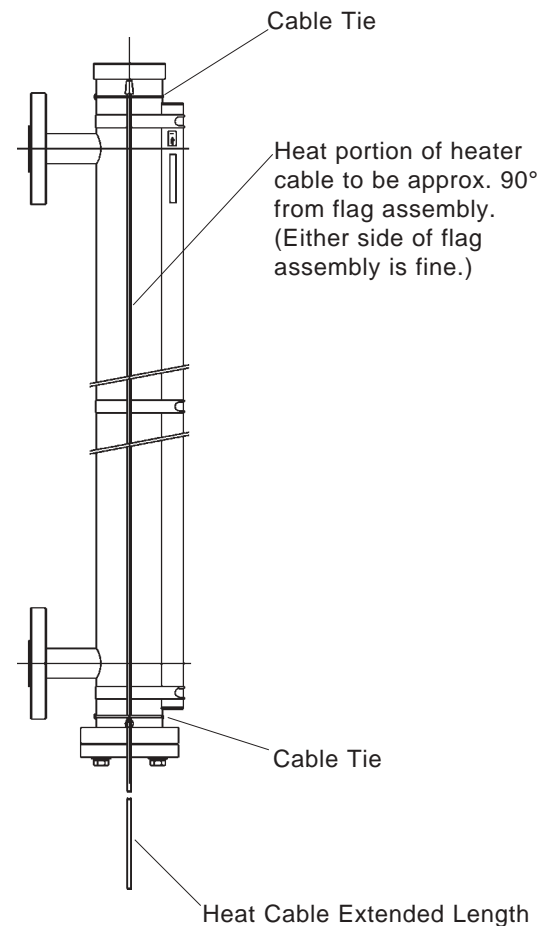

Gems Sensors Inc.
One Cowles Road
Plainville, CT
06062.1198

tel 860.747.3000
fax 860.747.4244

SureSite® Magnetic Liquid Level Indicator

Installation, Operation and Maintenance
Bulletin No. 177664-9 (Rev A)



Section 9: Cold Service

Installation

Standard SureSite

Cold service insulation has been completely installed on the SureSite Magnetic Level Indicator at the factory; except for the insulated cap assembly, which must be installed in conjunction with the installation of the Gems SureSite.

For Top and/or Bottom NPT Connections:

1. Remove the flange and install the float into the unit. Refer to "Section 1: Weldments" of Instruction Bulletin #177664 for detailed instructions.
2. After the float has been installed, reinstall the flange, using the gasket and bolts. Refer to the torque chart in the "Weldments" section for the appropriate torque value for the bolts.

Note

The insulated cap assembly must first be installed on the connecting pipe from the tank, prior to starting the pipe-joint connections.

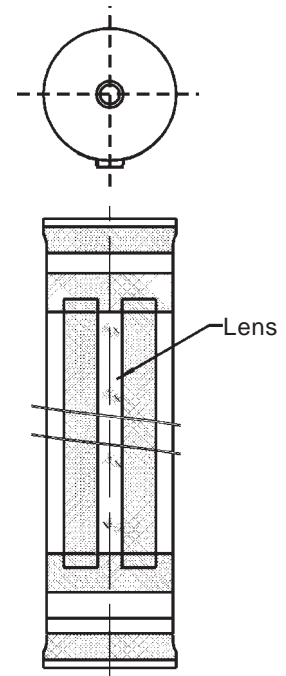

3. Before mating the SureSite Magnetic Level Indicator to your connecting piping, slide the insulated cap assembly back (toward the tank), far enough to permit completion of the pipe joint assembly, using the appropriate pipe thread sealant.
4. With the top and bottom pipe joint completed, slide the insulated cap assembly until it is flush with the SureSite insulation, and wrap the circumferential joint with the special tape supplied.
5. Apply an appropriate cold service sealant around the pipe/insulation interface.

For NPT/Flange Side Branch Connections:

1. Remove the flange and install the float into the unit. Refer to Section 1 of this Instruction Bulletin (“Weldments”) for detailed instructions.
2. After the float has been installed, reinstall the flange, using the gasket and bolts. Refer to the torque chart in the “Weldments” section for the appropriate torque value for the bolts.
3. Place the insulation end cap assembly over the bottom flange, flush with the SureSite insulation.

Note

If the top or bottom NPT connection is plugged (i.e., welded cap with plugged NPT), remove the tape from the cap, apply the appropriate pipe thread sealant and complete the pipe joint. Using an appropriate cold service sealant, seal around the pipe and insulation interface.

4. Wrap the circumferential joint with the special tape supplied.
5. Complete the installation of your SureSite Indicator according to the instructions provided, using an appropriate thread sealant and/or gasket material.



Gems Sensors Inc.
One Cowles Road
Plainville, CT
06062.1198

tel 860.747.3000
fax 860.747.4244

X-ON Electronics

Largest Supplier of Electrical and Electronic Components

Click to view similar products for [Flow Sensors](#) category:

Click to view products by [Gems Sensors](#) manufacturer:

Other Similar products are found below :

[VSR-3](#) [SS-12225](#) [AWM43300VH](#) [AWM730P1](#) [HAFBLF0400C5AX3](#) [FS1010-C01](#) [UF25B100](#) [FS15LF](#) [FS22A](#) [FS1012-1100-NG](#) [FS1012-1020-NG](#) [FS2012-1100-NG](#) [SFM3000-200C](#) [G-MAFCO-005](#) [SFM3000-200](#) [FPP800KIT1](#) [TDC-GP21](#) [T&R](#) [HAFBLF0100C4AX5](#) [HAFBLF0400C4AX3](#) [HAFBLF0050C4AX3](#) [SFM4100](#) [Air](#) [156268](#) [70824](#) [129660](#) [155421](#) [155481](#) [173931-C](#) [173250](#) [87480](#) [ATS-FM-22](#) [ATS-FM-34](#) [ATS-FM-44](#) [ATS-FM-66](#) [ATS-FM-M](#) [81501025](#) [81525101](#) [81526001](#) [81529003](#) [81529004](#) [81529005](#) [81529006](#) [81529007](#) [81529008](#) [81529010](#) [81529025](#) [81529901](#) [FS15A](#) [FS-90/1](#) [HAFBSS0200C2AX5](#) [AWM1200V](#)