



DUAL TTL-to-DIFFERENTIAL PECL TRANSLATOR

SY10ELT22
SY100ELT22

FEATURES

- 300ps typical propagation delay
- <100ps output-to-output skew
- Differential PECL outputs
- PNP TTL inputs for minimal loading
- Flow-through pinouts
- Available in 8-pin SOIC package

DESCRIPTION

The SY10/100ELT22 are dual TTL-to-differential PECL translators. Because PECL (Positive ECL) levels are used, only +5V and ground are required. The small outline 8-lead SOIC package and the low skew, dual gate design of the ELT22 makes it ideal for applications which require the translation of a clock and a data signal.

The ELT22 is available in both ECL standards: the 10ELT is compatible with positive ECL 10H logic levels, while the 100ELT is compatible with positive ECL 100K logic levels.

PIN NAMES

Pin	Function
Q _n	Differential PECL Outputs
D _n	TTL Inputs
V _{cc}	+5.0V Supply
GND	Ground

PACKAGE/ORDERING INFORMATION

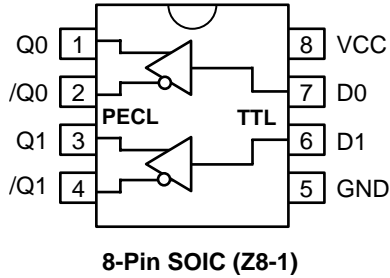

Ordering Information⁽¹⁾

Part Number	Package Type	Operating Range	Package Marking	Lead Finish
SY10ELT22ZC	Z8-1	Commercial	HEL22	Sn-Pb
SY10ELT22ZCTR ⁽²⁾	Z8-1	Commercial	HEL22	Sn-Pb
SY100ELT22ZC	Z8-1	Commercial	XEL22	Sn-Pb
SY100ELT22ZCTR ⁽²⁾	Z8-1	Commercial	XEL22	Sn-Pb
SY100ELT22ZI	Z8-1	Industrial	XEL22	Sn-Pb
SY100ELT22ZITR ⁽²⁾	Z8-1	Industrial	XEL22	Sn-Pb
SY10ELT22ZG ⁽³⁾	Z8-1	Industrial	HEL22 with Pb-Free bar-line indicator	Pb-Free NiPdAu
SY10ELT22ZGTR ^(2, 3)	Z8-1	Industrial	HEL22 with Pb-Free bar-line indicator	Pb-Free NiPdAu
SY100ELT22ZG ⁽³⁾	Z8-1	Industrial	XEL22 with Pb-Free bar-line indicator	Pb-Free NiPdAu
SY100ELT22ZGTR ^(2, 3)	Z8-1	Industrial	XEL22 with Pb-Free bar-line indicator	Pb-Free NiPdAu

Notes:

1. Contact factory for die availability. Dice are guaranteed at T_A = 25°C, DC Electricals only.
2. Tape and Reel.
3. Pb-Free package is recommended for new designs.

ABSOLUTE MAXIMUM RATINGS⁽¹⁾

Symbol	Parameter	Value	Unit
VCC	Power Supply Voltage	-0.5 to +7.0	V
Vi	TTL Input Voltage	-0.5 to VCC	V
Ii	TTL Input Current	-30 to +5.0	mA
IOUT	PECL Output Current		mA
	— Continuous	50	
	— Surge	100	
TLEAD	Lead Temperature (soldering, 20sec.)	+260	°C
Tstore	Storage Temperature	-65 to +150	°C
TA	Operating Temperature	-40 to +85	°C

TRUTH TABLE

D	Q	\bar{Q}
H	H	L
L	L	H
Open	H	L

NOTE:

- Permanent device damage may occur if absolute maximum ratings are exceeded. This is a stress rating only and functional operation is not implied at conditions other than those detailed in the operational sections of this data sheet. Exposure to absolute maximum rating conditions for extended periods may affect device reliability.

DC ELECTRICAL CHARACTERISTICS⁽¹⁾

VCC = VCC (Min.) to VCC (Max.)

Symbol	Parameter	TA = -40°C		TA = 0°C		TA = +25°C		TA = +85°C		Unit	Condition
		Min.	Max.	Min.	Max.	Min.	Max.	Min.	Max.		
ICC	Power Supply Current	—	30	—	30	—	30	—	30	mA	—

NOTE:

- Parametric values specified at: 5 volt Power Supply Range 100ELT22 Series: +4.2V to +5.5V.
10ELT22 Series +4.75V to +5.5V.

TTL DC ELECTRICAL CHARACTERISTICS⁽¹⁾

VCC = VCC (Min.) to VCC (Max.)

Symbol	Parameter	TA = -40°C		TA = 0°C		TA = +25°C		TA = +85°C		Unit	Condition
		Min.	Max.	Min.	Max.	Min.	Max.	Min.	Max.		
VIH	Input HIGH Voltage	2.0	—	2.0	—	2.0	—	2.0	—	V	—
VIL	Input LOW Voltage	—	0.8	—	0.8	—	0.8	—	0.8	V	—
IiH	Input HIGH Current	—	20 100	—	20 100	—	20 100	—	20 100	μA	VIN = 2.7V VIN = VCC
IiL	Input LOW Current	—	-0.2	—	-0.2	—	-0.2	—	-0.2	mA	VIN = 0.5V
VIK	Input Clamp Voltage	—	-1.2	—	-1.2	—	-1.2	—	-1.2	V	IIN = -18mA

NOTE:

- Parametric values specified at: 5 volt Power Supply Range 100ELT22 Series: +4.2V to +5.5V.
10ELT22 Series +4.75V to +5.5V.

PECL DC ELECTRICAL CHARACTERISTICS⁽¹⁾

VCC = VCC (Min.) to VCC (Max.)

Symbol	Parameter	TA = -40°C			TA = 0°C			TA = +25°C			TA = +85°C			Unit
		Min.	Typ.	Max.	Min.	Typ.	Max.	Min.	Typ.	Max.	Min.	Typ.	Max.	
VOH	Output HIGH Voltage ⁽²⁾													mV
	10ELT	3920	—	4110	3980	—	4160	4020	—	4190	4090	—	4280	
	100ELT	3915	—	4120	3975	—	4120	3975	—	4120	3975	—	4120	
VOL	Output LOW Voltage ⁽²⁾													mV
	10ELT	3050	—	3350	3050	—	3370	3050	—	3370	3050	—	3405	
	100ELT	3170	—	3445	3190	—	3380	3190	—	3380	3190	—	3380	

NOTES:

- Parametric values specified at: 5 volt Power Supply Range 100ELT22 Series: +4.2V to +5.5V.
10ELT22 Series +4.75V to +5.5V.
- These values are for VCC = 5.0V. Level Specifications will vary 1:1 with VCC.

AC ELECTRICAL CHARACTERISTICS⁽¹⁾

VCC = VCC (Min.) to VCC (Max.)

Symbol	Parameter	TA = -40°C		TA = 0°C		TA = +25°C		TA = +85°C		Unit	Condition
		Min.	Max.	Min.	Max.	Min.	Max.	Min.	Max.		
tPD	Propagation Delay to Output D, ENECL/ENTTL	100	600	100	600	100	600	100	600	ps	50Ω to VCC – 2.0V
tr tf	Output Rise/Fall Time 20% to 80%	200	500	200	500	200	500	200	500	ps	50Ω to VCC – 2.0V
tskpp	Part-to-Part Skew ⁽²⁾	—	500	—	500	—	500	—	500	ps	50Ω to VCC – 2.0V
tskew	Within-Device Skew ^(2,3)	—	100	—	100	—	100	—	100	ps	50Ω to VCC – 2.0V

NOTE:

- Parametric values specified at: 5 volt Power Supply Range 100ELT22 Series: +4.2V to +5.5V.
10ELT22 Series +4.75V to +5.5V.
- Guaranteed, but not tested.
- Same transition @common VCC levels.

8-PIN SOIC .150" WIDE (Z8-1)

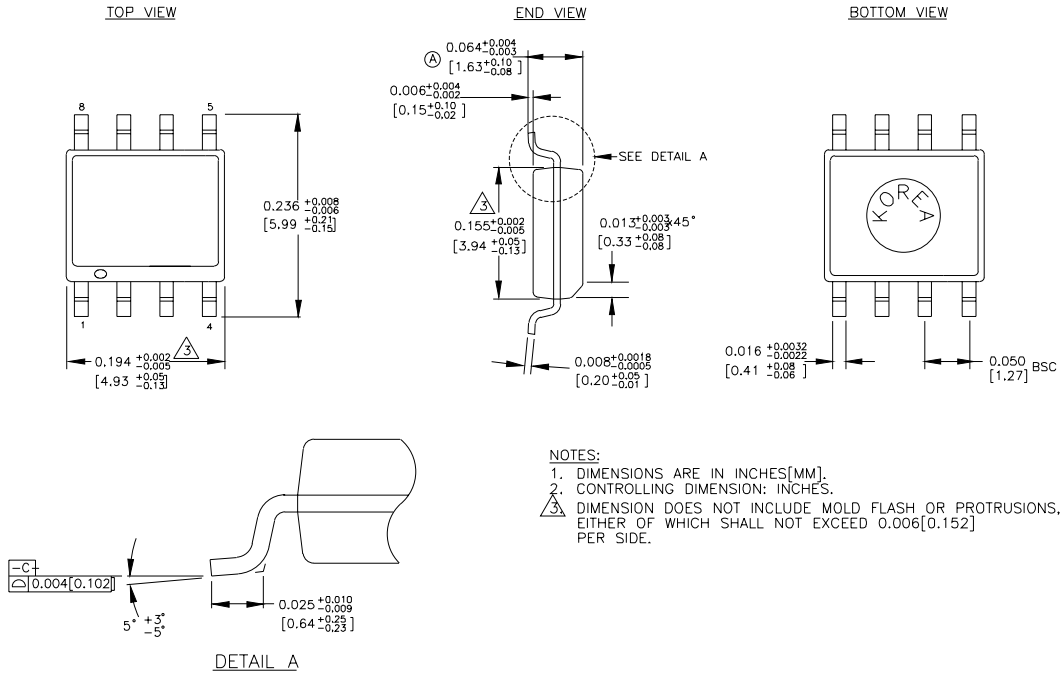

Rev. 03

MICREL, INC. 2180 FORTUNE DRIVE SAN JOSE, CA 95131 USA

TEL + 1 (408) 944-0800 FAX + 1 (408) 474-1000 WEB <http://www.micrel.com>

The information furnished by Micrel in this datasheet is believed to be accurate and reliable. However, no responsibility is assumed by Micrel for its use. Micrel reserves the right to change circuitry and specifications at any time without notification to the customer.

Micrel Products are not designed or authorized for use as components in life support appliances, devices or systems where malfunction of a product can reasonably be expected to result in personal injury. Life support devices or systems are devices or systems that (a) are intended for surgical implant into the body or (b) support or sustain life, and whose failure to perform can be reasonably expected to result in a significant injury to the user. A Purchaser's use or sale of Micrel Products for use in life support appliances, devices or systems is at Purchaser's own risk and Purchaser agrees to fully indemnify Micrel for any damages resulting from such use or sale.

© 2005 Micrel, Incorporated.

X-ON Electronics

Largest Supplier of Electrical and Electronic Components

Click to view similar products for [Translation - Voltage Levels](#) category:

Click to view products by [Microchip](#) manufacturer:

Other Similar products are found below :

[NLJVHC1GT08DFT2G](#) [NLSX4373DMR2G](#) [NLSX5012MUTAG](#) [HV583GA-G](#) [NLSX0102FCT1G](#) [NLSX0102FCT2G](#)
[NLSX4302EBMUTCG](#) [NLVSX4373DR2G](#) [PCA9306FMUTAG](#) [SY10H351JZ](#) [MC100EPT622MNG](#) [MAX9374AEKA+T](#) [MAX3378EETD+](#)
[MAX34405BEZT+](#) [NLSX3014MUTAG](#) [NVT4556BUKZ](#) [NLSV4T244EMUTAG](#) [NLSX5011MUTCG](#) [NLV9306USG](#)
[NLVSX4014MUTAG](#) [MAX34405BEZT+T](#) [NLSV4T3144MUTAG](#) [NSV12200LT1G](#) [NLVSX4373MUTAG](#) [NB3U23CMNTAG](#)
[MAX3371ELT+T](#) [MAX3008EUP+T](#) [NLVPCA9306AMUTCG](#) [NLSX3013BFCT1G](#) [MAX9378EUA+T](#) [NLV7WBD3125USG](#)
[NLV14504BDTG](#) [NLSX3012DMR2G](#) [NLSX5012DR2G](#) [MAX3391EEUD+T](#) [MAX3379EETD+](#) [PI4ULS3V4857GEAEX](#)
[MAX3391EEBC+T](#) [MAX14842ATE+T](#) [74AVCH1T45FZ4-7](#) [CLVC16T245MDGGREP](#) [HEF4104BT](#) [TC74LCX16245\(EL,F\)](#)
[MC10H124FNG](#) [CAVCB164245MDGGREP](#) [7WBD383USG](#) [NVT2001GM,115](#) [CLVC8T245MRHLTEP](#) [74LVC1G175GS,132](#)
[FXLA104UM12X](#)